

# BONIS SEWING MACHINES

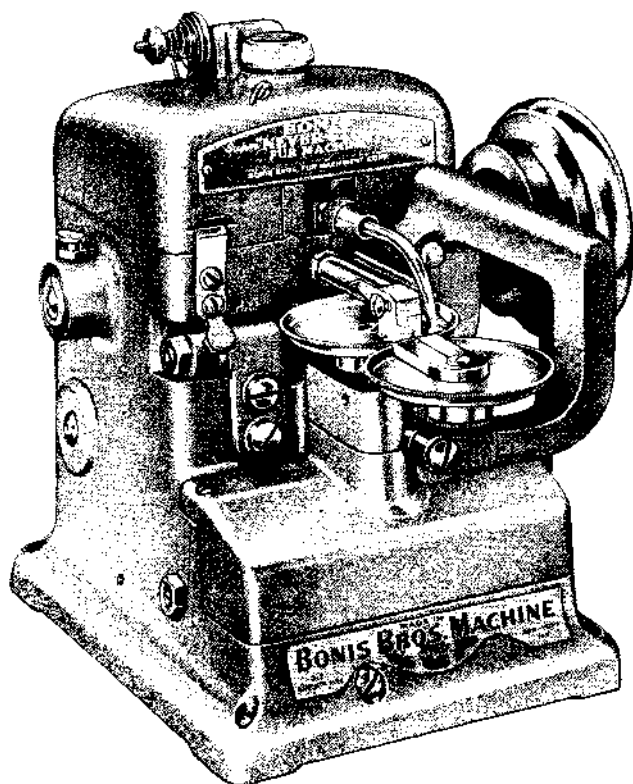

**Bonis Bros. Sewing Machinery Corp.**

131 WEST 29th STREET,

NEW YORK, N. Y. 10001

*Telephone:* (212) 563-6161



Cable Address  
"BONIBRO"

Telex 422449

From the library of: Superior Sewing Machine & Supply LLC

# THREADING

To thread the machine; take thread for #1 spool holder, through #2 rear pig tail (thread guide) forward and over between the tension discs #3, from top continue through front pigtail #4, down and through the hole #5 in the needle bar tension plate. Now turn the machine pulley until the needle bar tension plunger #6 opens; holding the thread tight, open front disc and pass thread under the needle and back under the needle bar into thread slot #7. Loop thread over tension plunger #6 draw forward, close up under the needle bar and into hole #8 in the tension plate through which the needle protrudes. Now, from the **underside**, pass the thread up through the needle eye #9. Make sure you follow these simple instructions by number.

## KEEP YOUR MACHINES CLEAN

### **MINOR ADJUSTMENTS**

When operating your machine, if it does not function properly, if it skips, or the thread breaks often, it may need some minor adjustment which you can very well do.

- 1 — Check front disc and see that it is running smoothly and not clogged with loose fur, remove needle plate, take wheel apart, wipe off entire wheel, rollers and stud. By doing this you will get excellent results in producing a proper even seam. It also eliminates skipping and thread breakage.
- 2 — Make sure needle plate slot is free of ridges and any foreign matter. Also be sure needle is not bent, see that tension is free of dirt. Take it apart and clean it.  
  
See that thread runs through eye of needle freely.
- 3 — Loosen two screws in needle bar yoke inside machine and push back needle bar a little. Sometimes it has to be moved one way or the other for better sewing results.

Take care of your Bonis Machine and it will take care of you with maximum efficiency under severe tests.

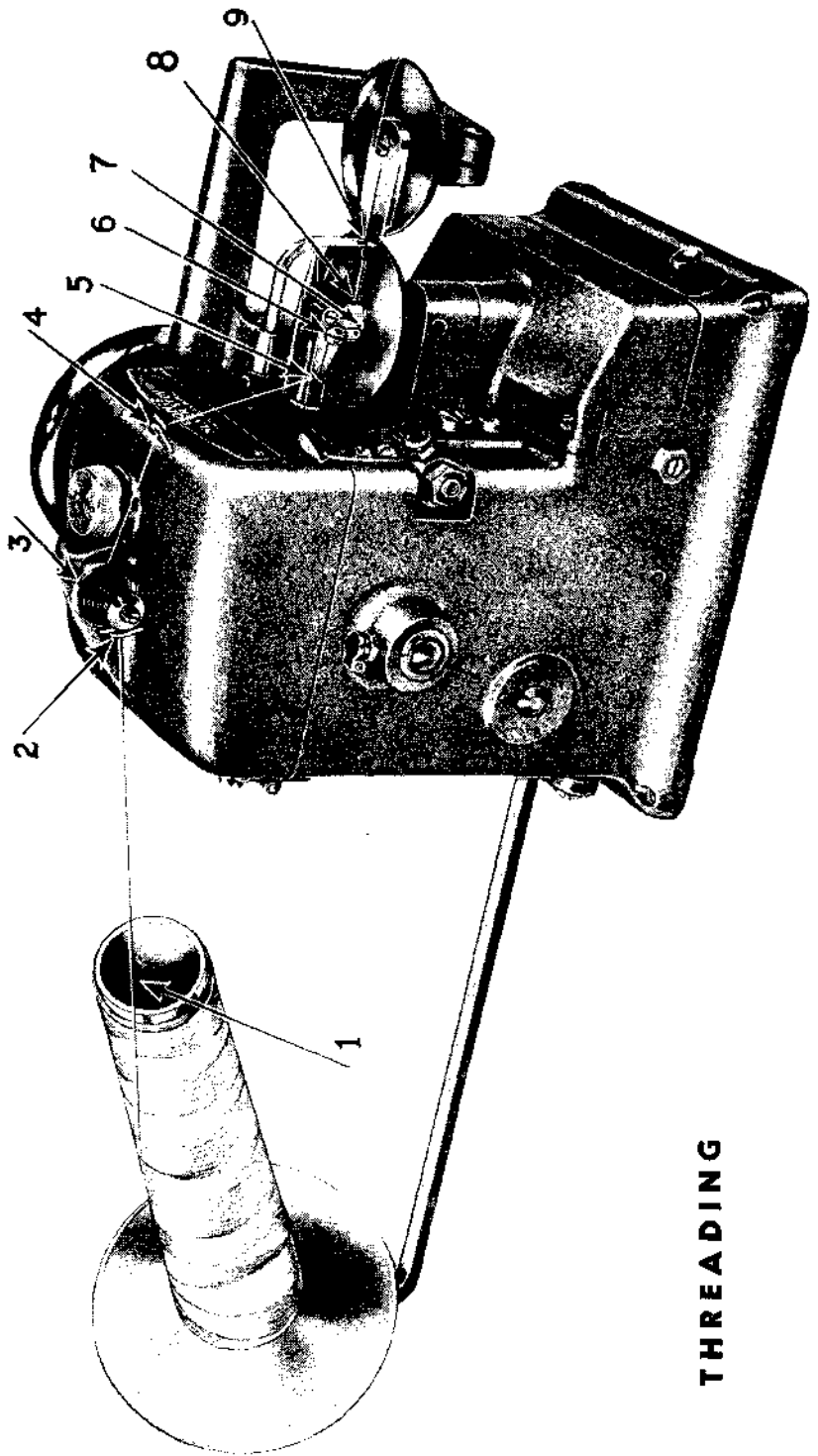

**THREADING**

When ordering parts - specify model of machine and type of work to be done, as there are various models of machines and some parts are interchangeable.

## BONIS SEWING MACHINE PARTS

Parts Number	Description
1-A	Main Frame
24	Belt Wheel
203	Belt Wheel Screw
29	Main Shaft Bushing -- long
30	Main Shaft Bushing -- short
105	Main Shaft
201	Pressure Lever Shaft Screw
224	Feed Shaft Screw Nut
248	Main Shaft Bushing Screw
409	Small Oil Cup

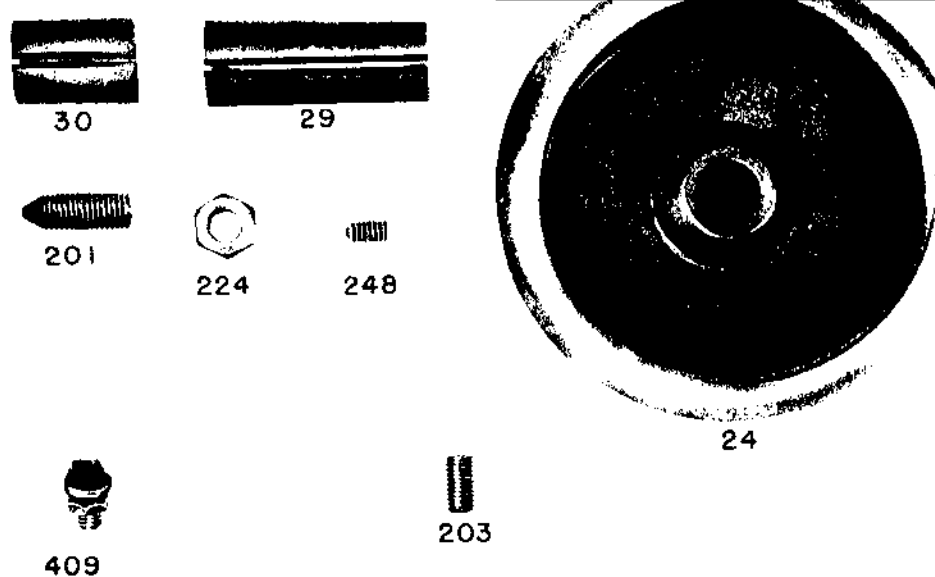

105

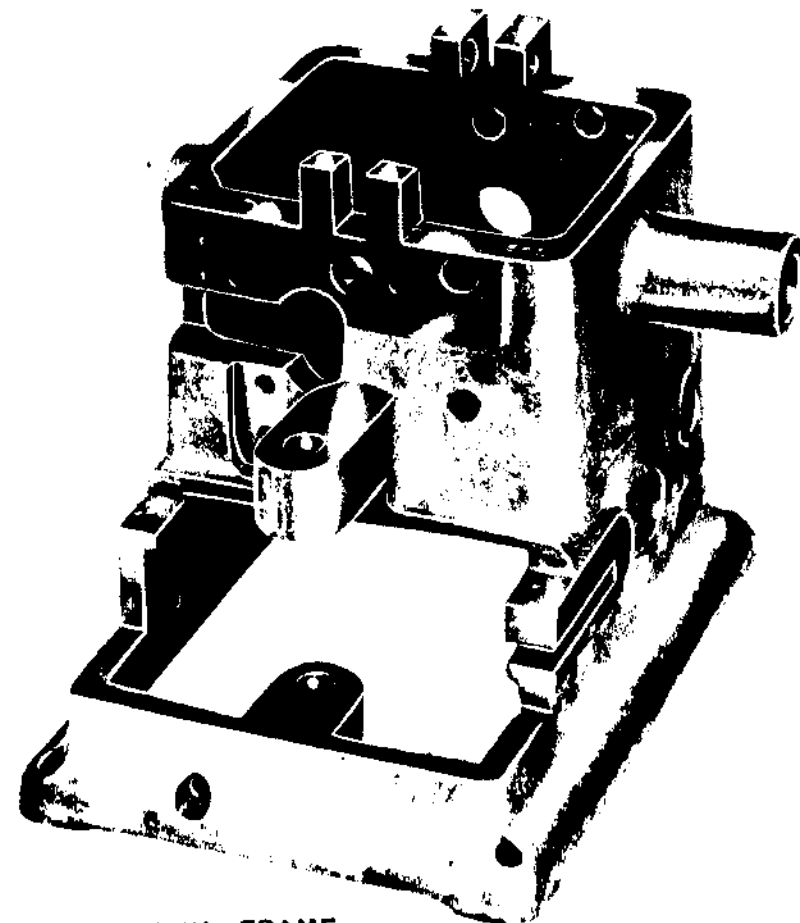

1-A MAIN FRAME

# BONIS SEWING MACHINE PARTS

Parts Number	Description
603	Top Cover
606	Top Cover Gasket
605	Top Cover Plate
607	Top Cover Set Screw
608	Top Cover Oil Well
610	Top Cover Lock Spring
611	Top Cover Hinge
612	Top Cover Hinge Stopper
405	Top Cover Hinge Screw
226	Tension Nut
213	Tension Post
133	Top Cover Tension Spring
129	Tension Disc
128	Top Cover Thread Guide

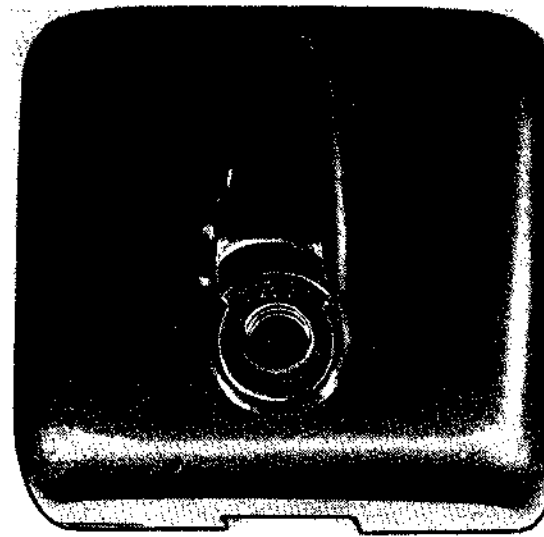

603

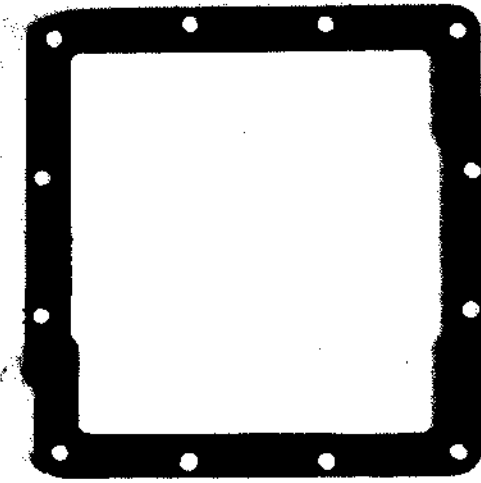

606

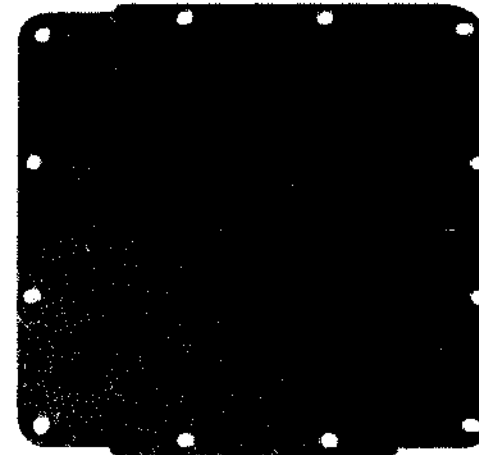

605



608



129



133



213



226



607



128



610



611



405



226

From the library of: Superior Sewing Machine & Supply LLC

# BONIS SEWING MACHINE PARTS

Parts Number	Description
619	Feed Disc Arm Complete With Pins
18-F	Front Feed Disc
18-R	Rear Feed Disc
107	Disc Stud
246	Disc Bearing Rollers
121	Needle Guard
127-A	Work Guide
230	Work Guide Set Screw
114-A	Looper
202	Rear Feed Disc Set Screw
623	Adjustable Spring Screw
622	Adjustable Seam Spring
621	Adjustable Seam Needle Guard
614	Needle Guard Screw

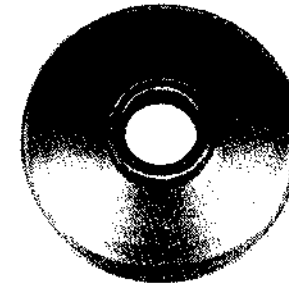
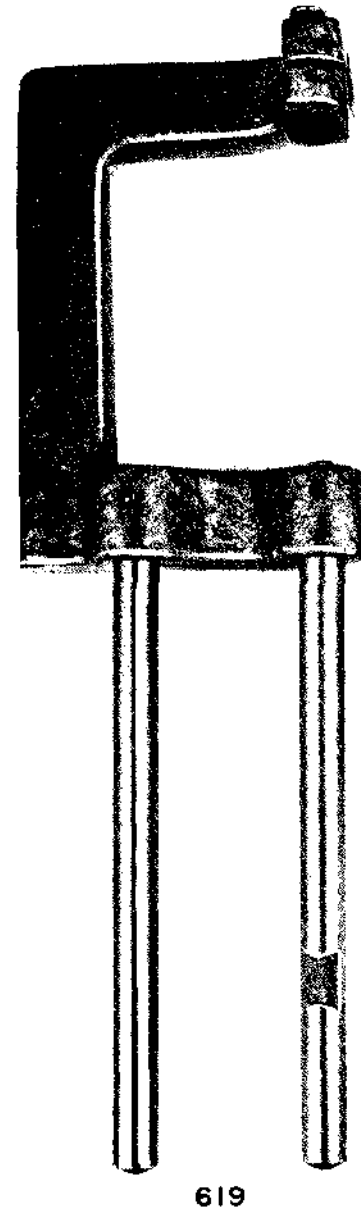

18 F

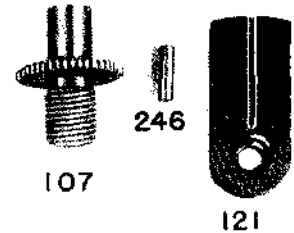

107

246

121

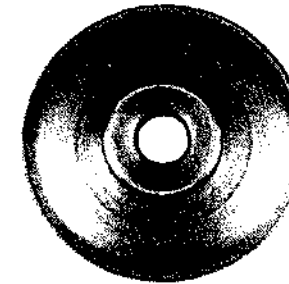

18 R

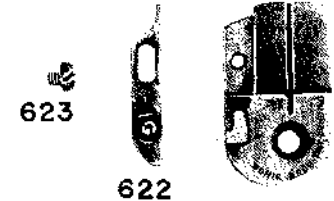

623

622

621



202

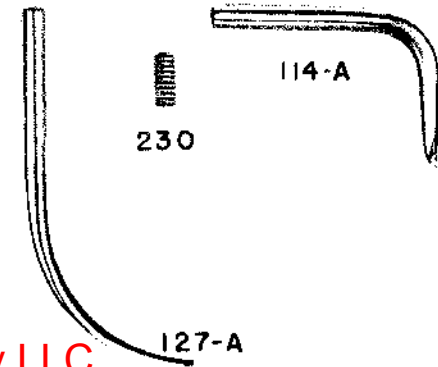

230

114-A

127-A



614

When ordering Discs please specify model of machine and size discs required or type of work used.

# BONIS SEWING MACHINE PARTS

Parts Number	Description
21	Pressure Lever
158	Pressure Lever Shaft
157	Pressure Lever Spring
259	Pressure Lever Adjusting Screw
250	Pressure Lever Adjusting Screw Nut
201	Pressure Lever Shaft Screw
14	Feed Connection
13	Feed Eccentric
15	Feed Lever
109	Stitch Regulating Stud
111	Stitch Regulating Block
123	Feed Lever Washer
228	Stitch Stud Nut
112	Stitch Indicator
110	Stitch Regulating Stud Nut
209	Feed Lever Screw
211	Feed Dog Driving Screw
235	Feed Eccentric Pin
202	Feed Eccentric Set Screw

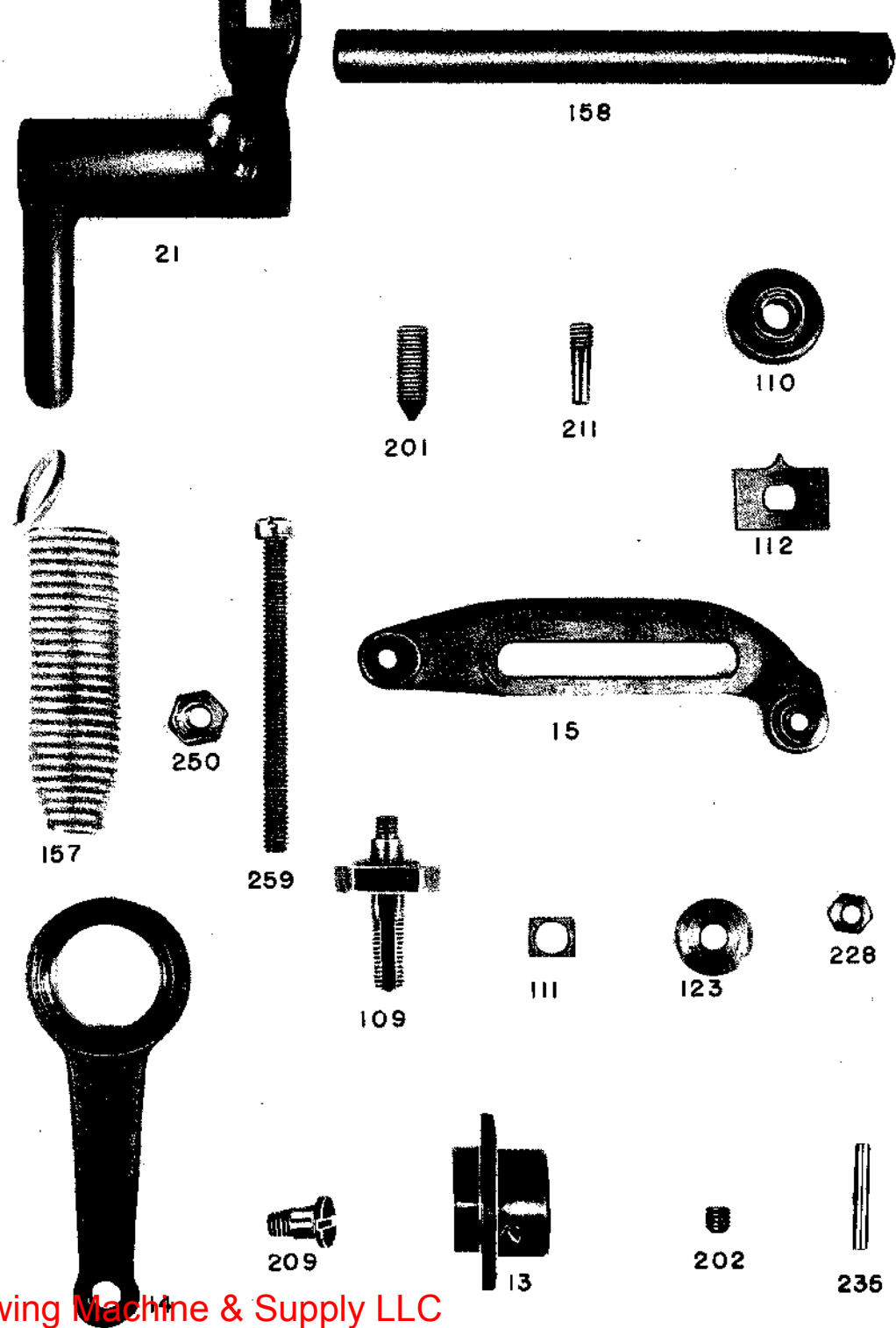

From the library of: Superior Sewing Machine & Supply LLC

# BONIS SEWING MACHINE PARTS

Parts Number	Description
416	Feed Gear
420	Feed Gear Cam
419	Feed Gear Ring
425	Feed Gear Plate
433	Feed Retaining Drum Plate Shoulder Screw
417	Feed Gear Shaft
418	Feed Gear Shaft Washer
426	Feed Gear Plate Set Screw
423	Feed Gear Roller Pin
424	Feed Gear Roller Spring
421	Feed Gear Roller
427	Feed Gear Cam Set Screw
628	Feed Retaining Drum
629	Feed Retaining Drum Cam
630	Feed Retaining Drum Plate
106	Disc Shaft
17	Feed Gear, Small
132	Feed Disc Shaft Spring
202	Feed Gear Set Screw

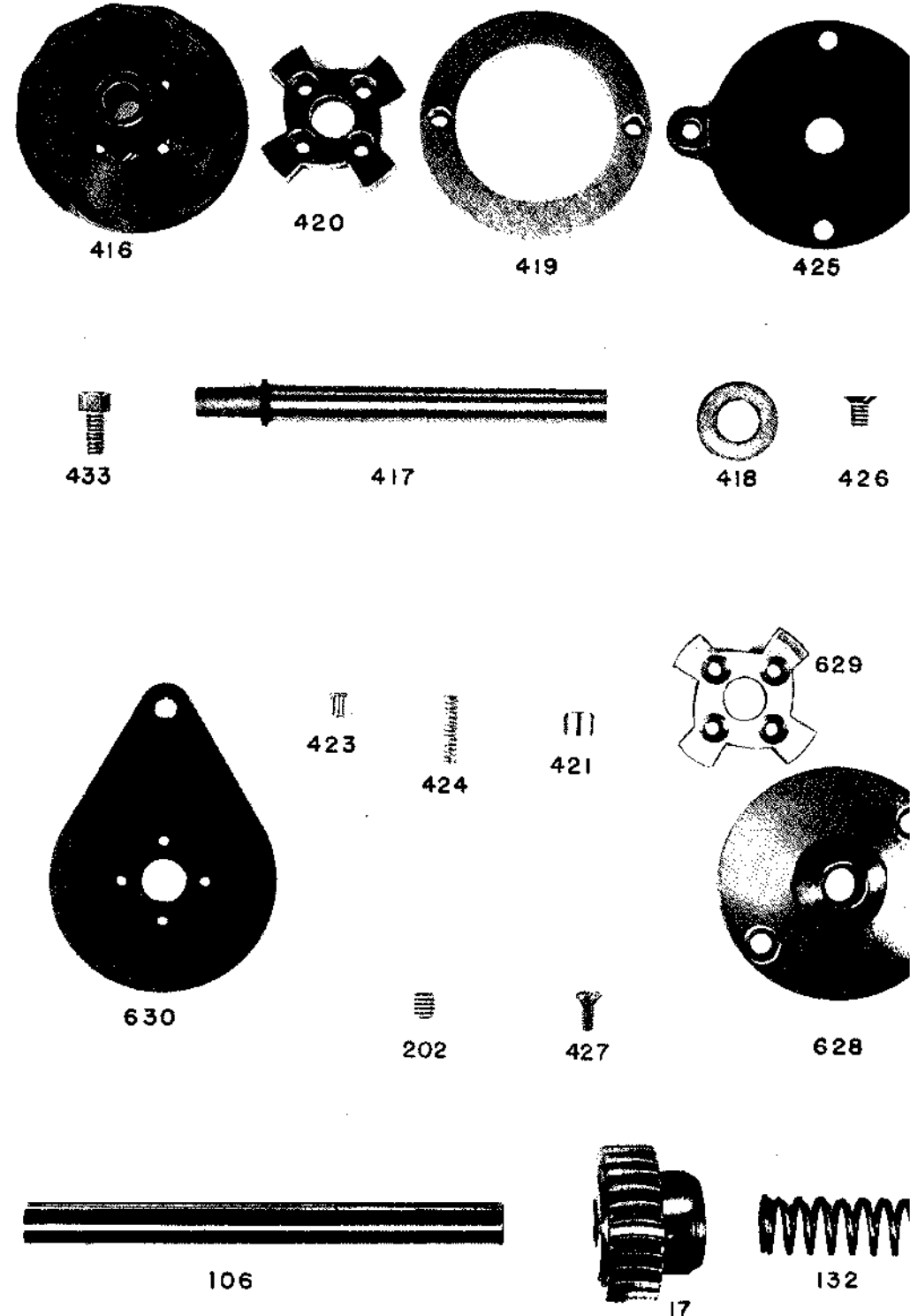



# BONIS SEWING MACHINE PARTS

Parts Number	Description
113½	Needle Bar
115	Needle Bar Tension Plate
217	Needle Bar Tension Plate Screw
215	Needle Bar Tension Plunger
134	Needle Bar Tension Spring
216	Needle Bar Tension Plunger Nut
227	Needle Clamp Screw
119	Needle Clamp
617	Super N. S. Needle Bar Bushing
229	Tension Post Screw
7-A	Needle Bar Yoke Eccentric
466	Needle Bar Yoke
467	Needle Bar Yoke Support Shaft
468	Needle Bar Yoke Support Shaft Lock Nut
469	Needle Bar Yoke Adjustable Bracket
218	Needle Bar Yoke Pinch Screw
116	Needle Bar Tension Post
210	Needle Bar Yoke Adjustable Bracket Screw
202	Yoke Eccentric Set Screw

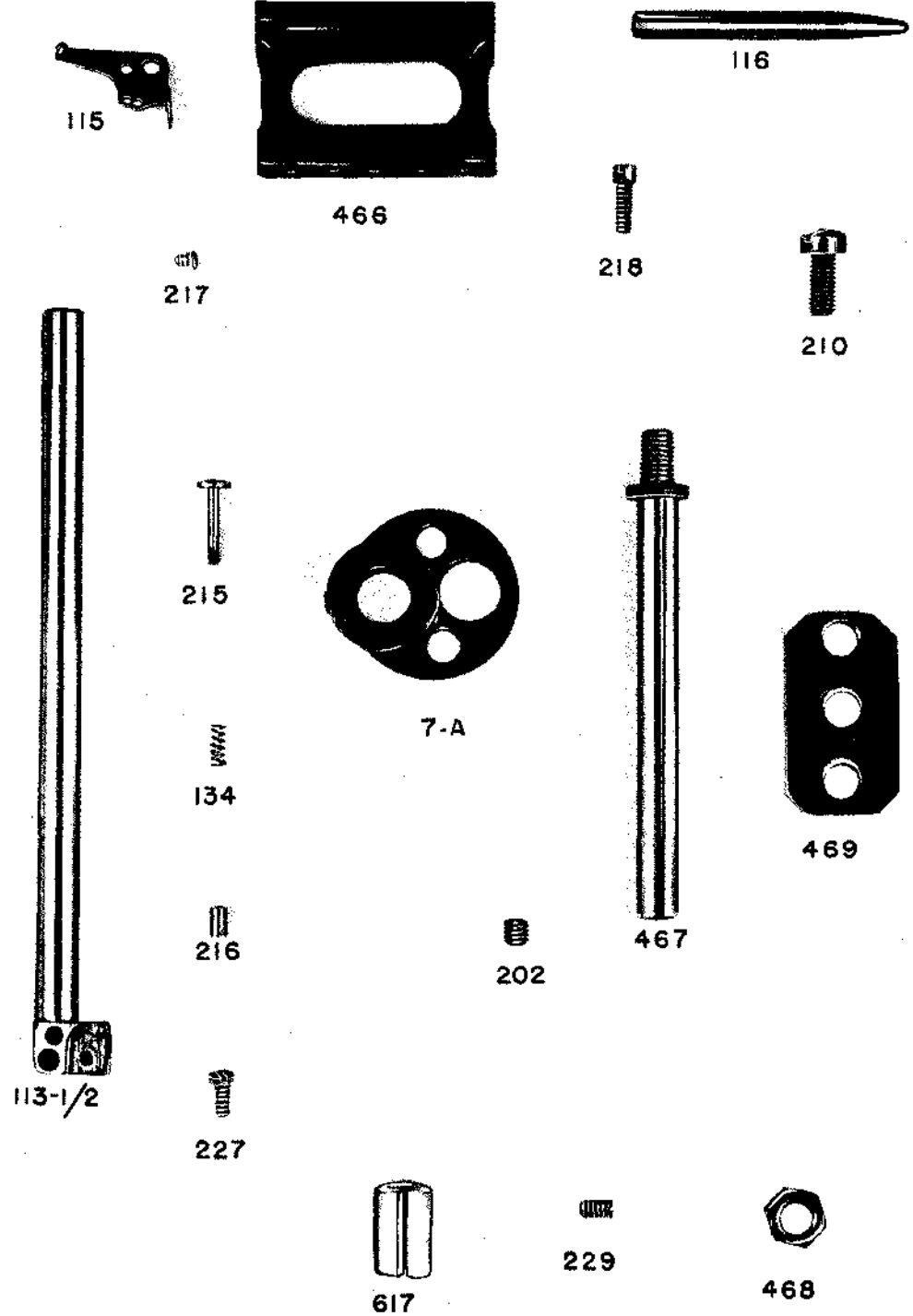

From the library of: Superior Sewing Machine & Supply LLC

# BONIS SEWING MACHINE PARTS

Parts Number	Description
639	Looper Oscillating Arm Pinch Screw
609	Looper Oscillating Arm
208	Looper Cam Roller Stud Set Screw
207	Looper Cam Roller Stud
126	Looper Oscillating Roller
624	Looper Shaft
125	Looper Chuck Shell
144-A	Looper Frame
412	Looper Frame Rocker Nut
410	Looper Rocker Bracket
422	Looper Frame Rocker
204	Looper Frame Fulcrum Pin
205	Looper Frame Rocker Stud
206	Looper Frame Rocker Bracket Screw
143	Rocker Packing
225	Looper Frame Fulcrum Pin Nut
411-A	Looper Frame Hardened Steel Eccentric
234	Looper Eccentric Pin
27	Balance Weight
214	Balance Weight Screw
202	Eccentric Set Screw
149-A	Oscillating Cam

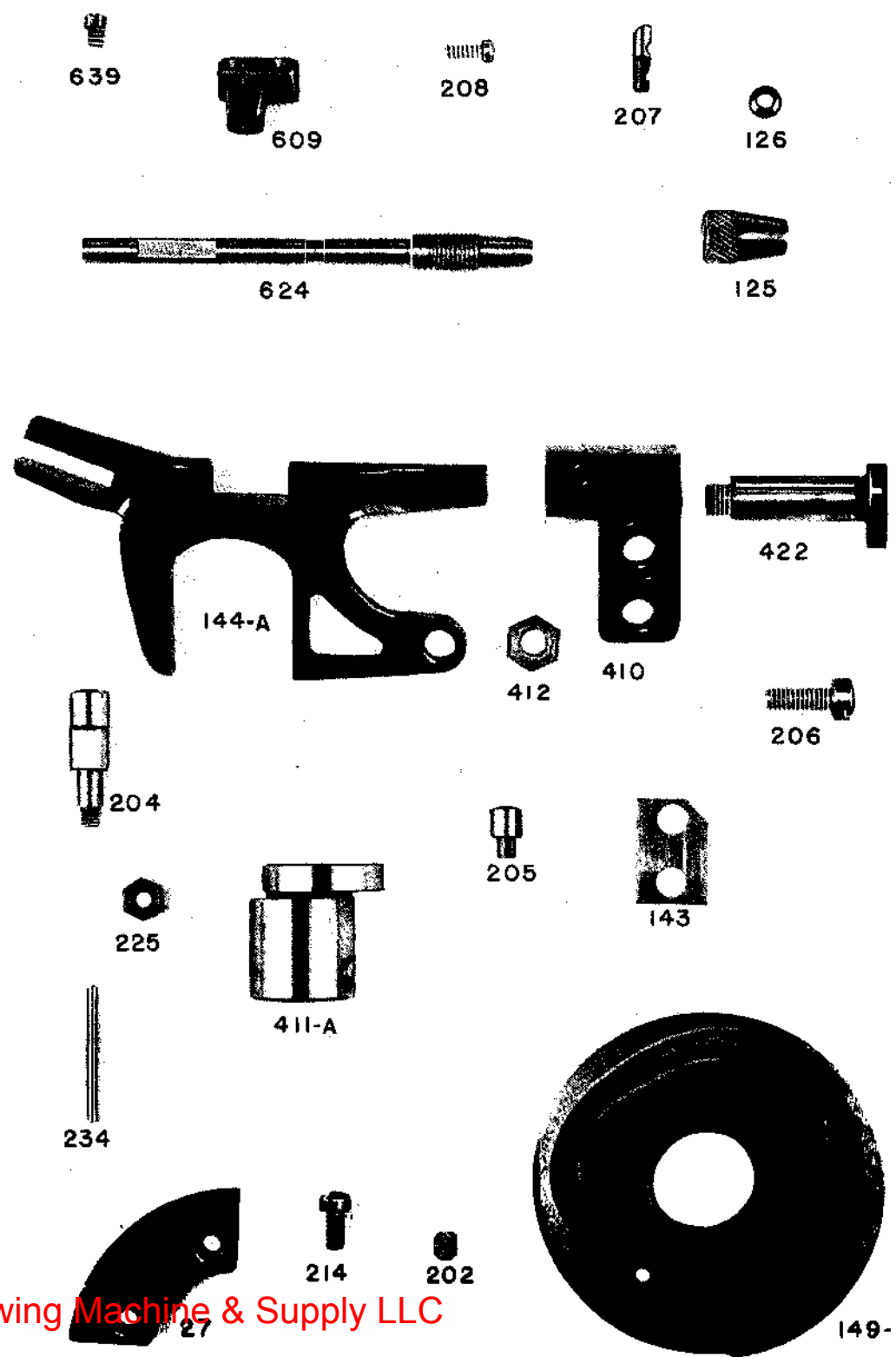

From the library of: Superior Sewing Machine & Supply LLC

# BONIS SEWING MACHINE PARTS

Parts Number	Description
602	Base Plate
613	Base Plate Wood Screw
219	Base Screw
434	Base Plate Oil Pipe
435	Oil Pipe Flange
436	Oil Bottle
437	Oil Bottle Lock Spring
604	Front Cover
221	Front Cover Screw

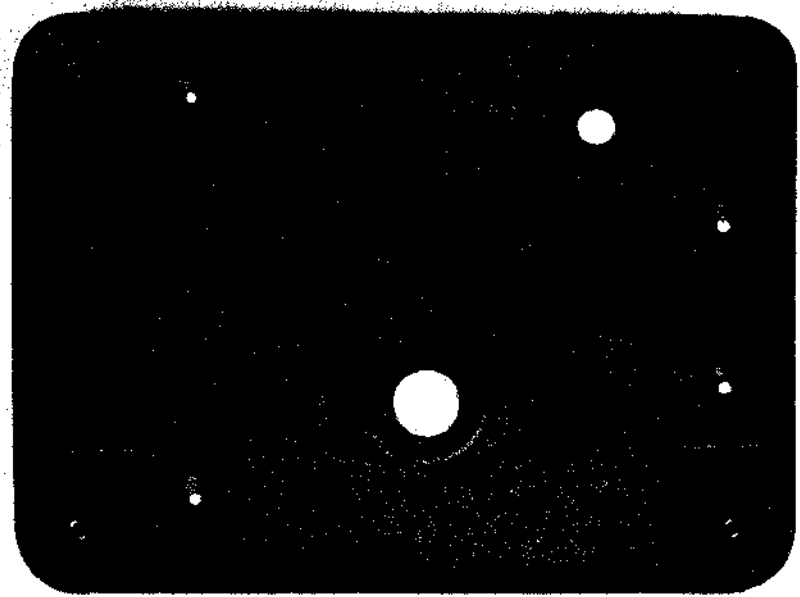

602



613



219

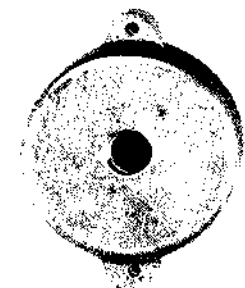

435

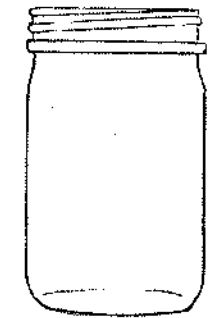

436

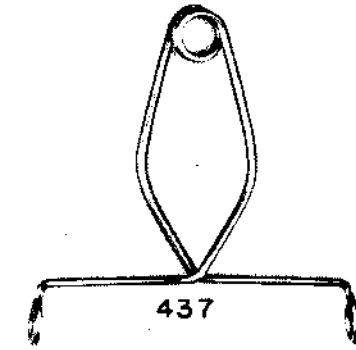

437



221



604



221

From the library of: Superior Sewing Machine & Supply LLC

# BONIS

## "NEVER-STOP" MODEL

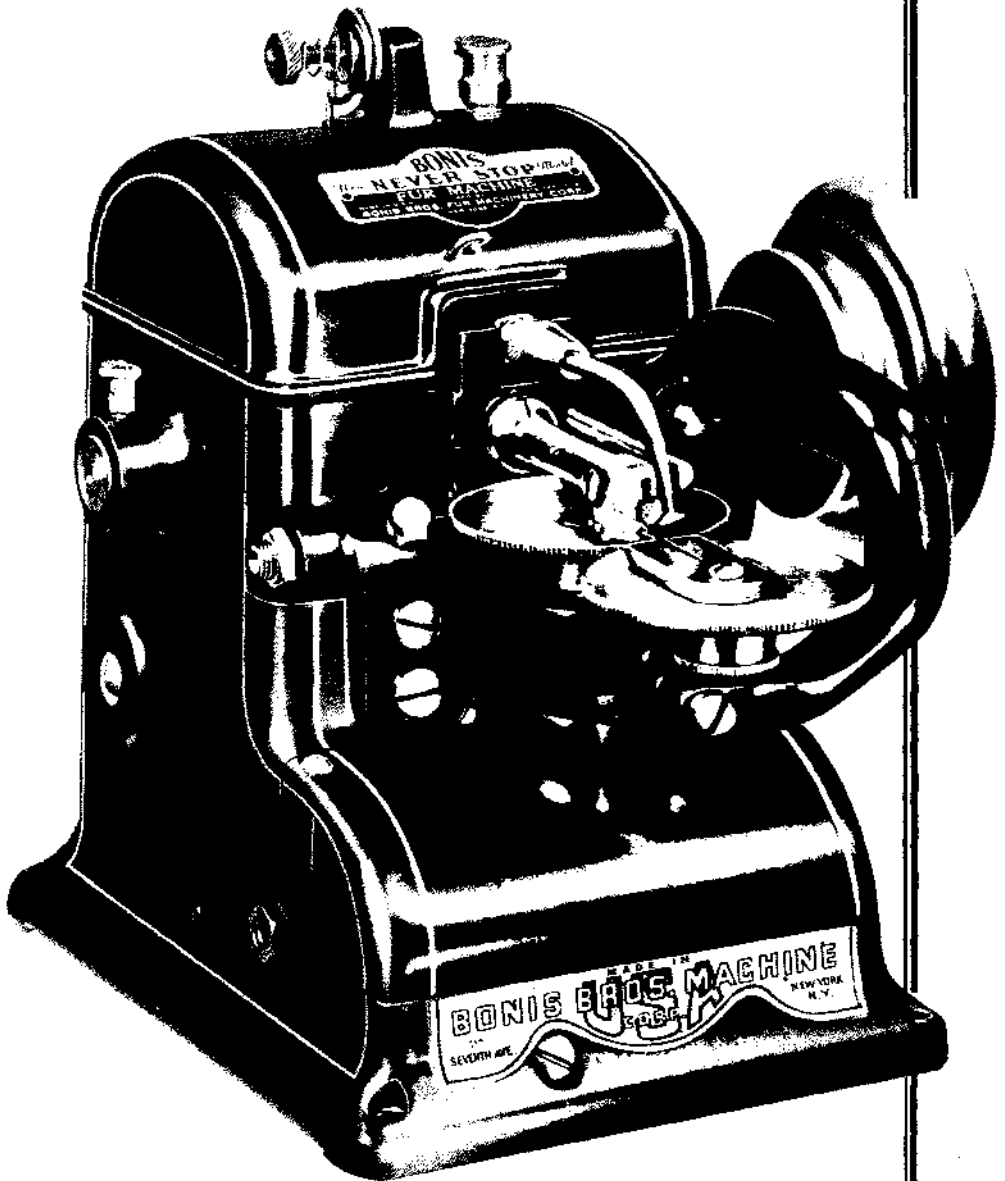

# BONIS MODEL B SEWING MACHINE PARTS

Parts Number	Description
113½-B	Needle Bar
149-B	Oscillating Cam
7-B	Needle Bar Yoke Eccentric
202	Yoke Eccentric Set Screw
122-B	Looper Frame Rocker
10-B	Looper Rocker Bracket
121-B	Needle Guard
205	Looper Frame Rocker Stud
144-B	Looper Frame
1-B	Main Frame
127-B	Work Guide
114-B	Looper

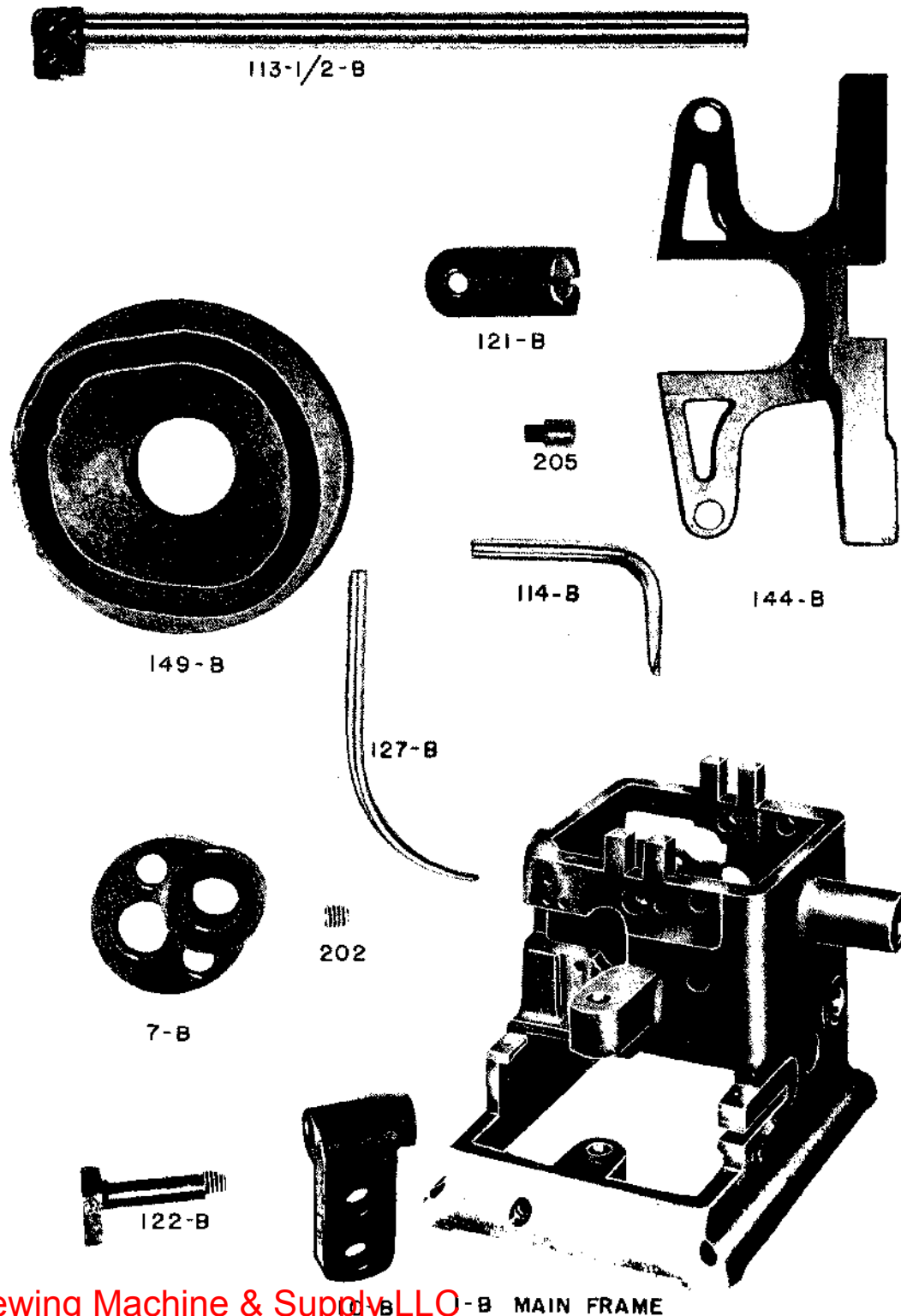

From the library of: Superior Sewing Machine & Supply LLO - B MAIN FRAME

## BONIS MODEL T SEWING MACHINE PARTS

Parts Number	Description
113½-T	Needle Bar
149-T	Oscillating Cam
7-T	Needle Bar Yoke Eccentric
202	Yoke Eccentric Set Screw
122-T	Looper Frame Rocker
10-T	Looper Rocker Bracket
121-T	Needle Guard
205	Looper Frame Rocker Stud
144-T	Looper Frame
411-T	Looper Frame Hardened Steel Eccentric
410-T	Looper Rocker Bracket
422-T	Looper Frame Rocker
127-T	Work Guide
114-T	Looper
1-T	Main Frame

If you are ordering for a T machine and order part not listed on this particular page, please specify "for Model T machine".

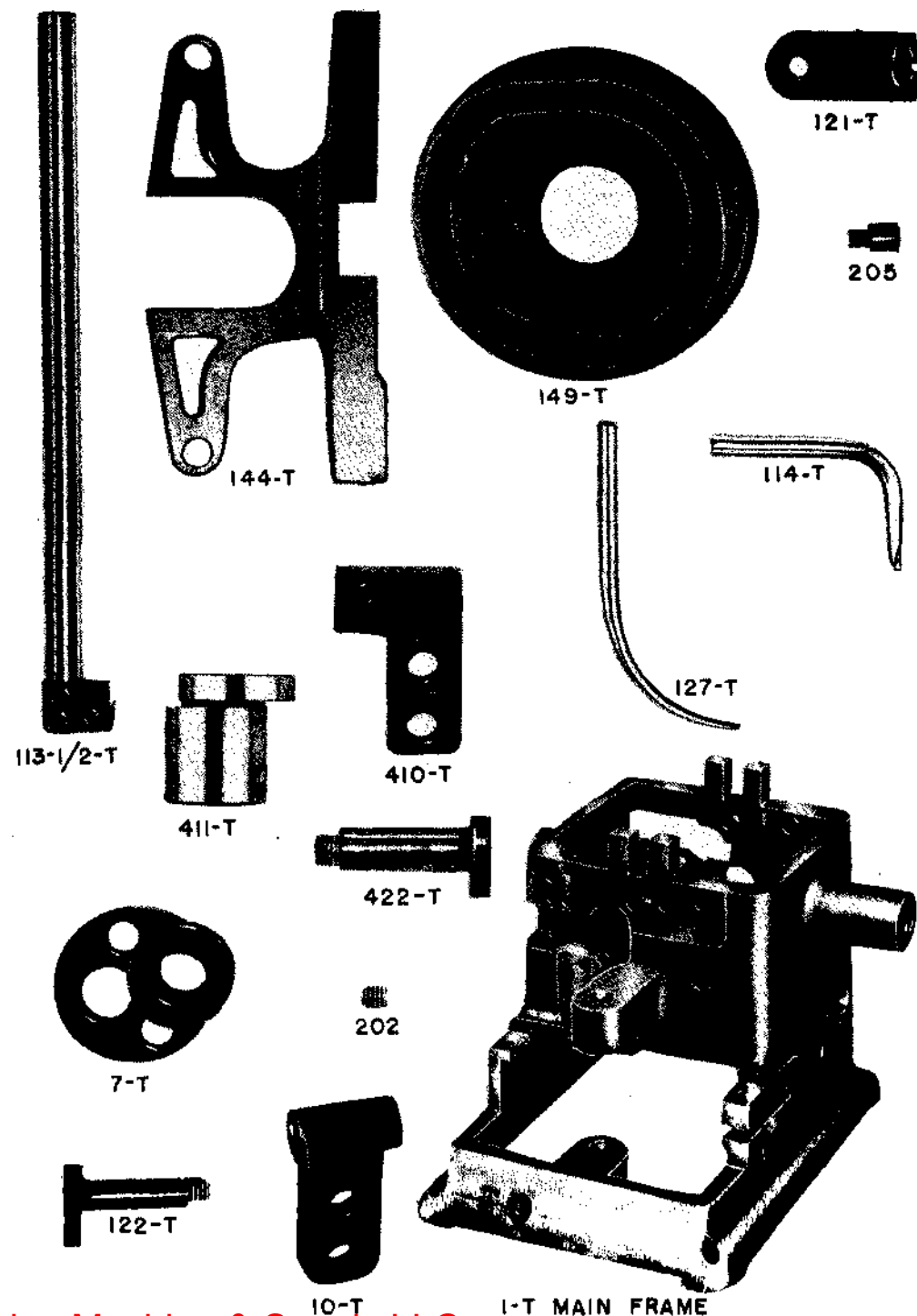

From the library of: Superior Sewing Machine & Supply LLC

# BONIS SEWING MACHINE PARTS

Parts Number	Description
25	Cotton Stand
210	Cotton Stand Screw
26	Treadle Lever
MT 165	Treadle Rod
MT 164	Treadle Rod Bottom
MT 142	Treadle Rod Top
MT 311	Treadle Rod Cotter Pin
MT 166	Treadle Rod Clamp
MT 167	Treadle Rod Clamp Screw
MT 172	Treadle Rod Clamp
MT 251	Treadle Rod Clamp Screw
	A C Treadle Rod Spring
	Oil Can
	Chain
	Tweezers
	Screw Driver

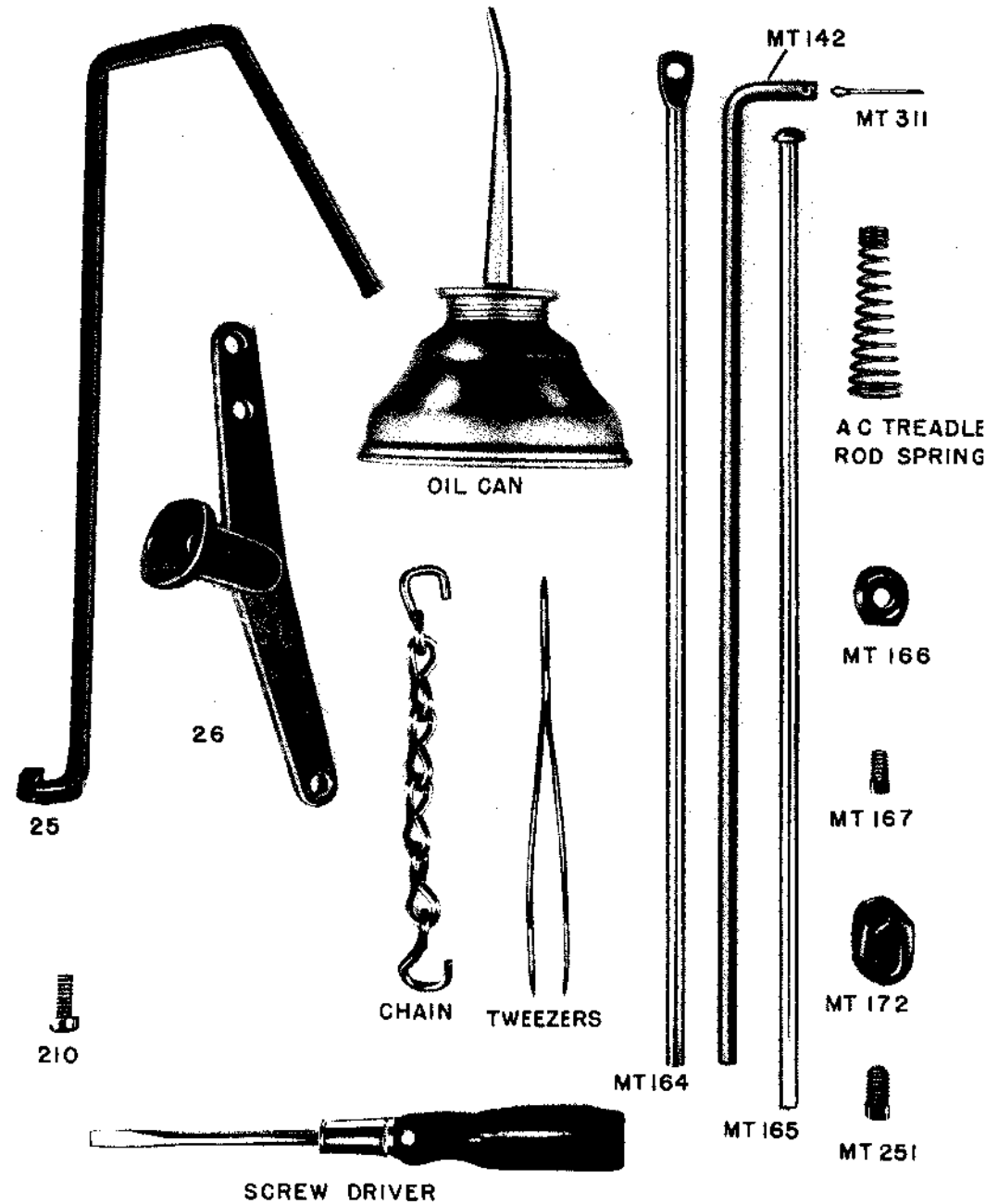

From the library of: Superior Sewing Machine & Supply LLC

# Bonis Sewing Machine Mounted on Electric Motor Stand

- Bonis A. C. Motors and Stands are built to run easily and quietly. They eliminate the continuous humming sound of the old type motors and reduce the cost of electricity considerably.
- Bonis D. C. Electric Motor Stands are constructed to operate machines at a high point of efficiency combining smoothness with speed.

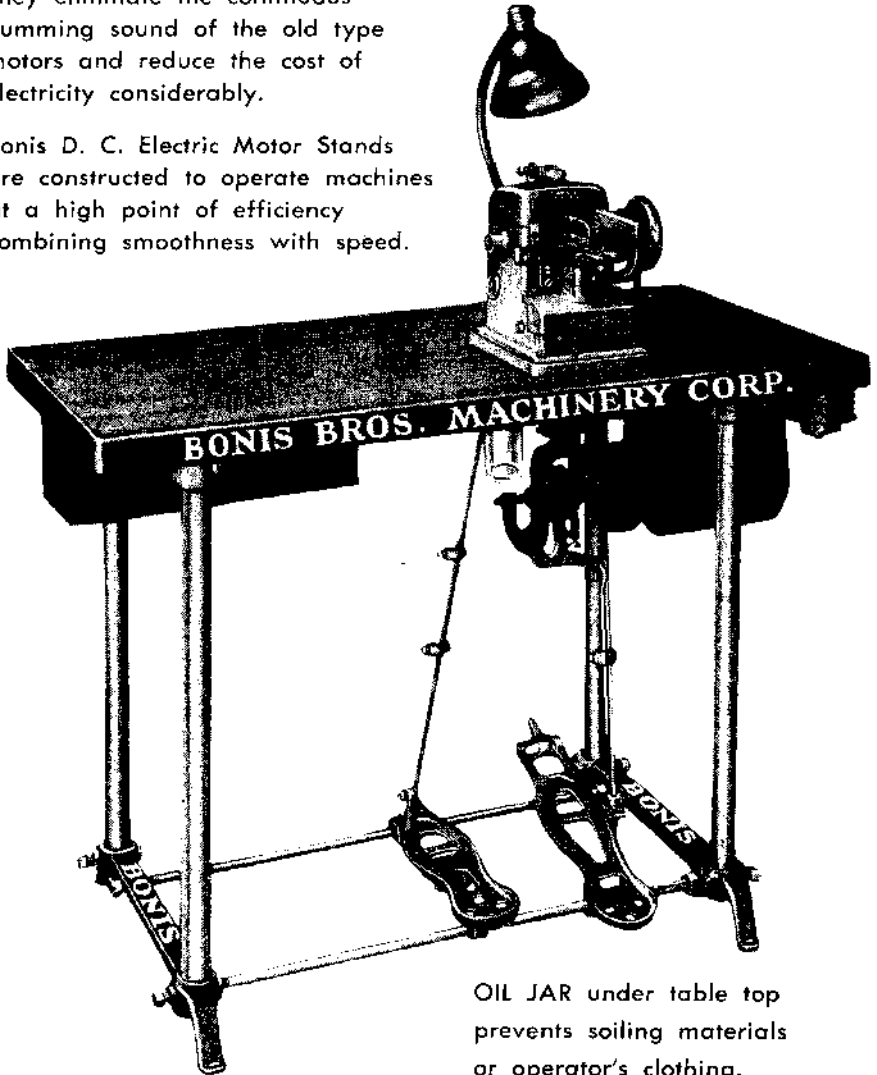

OIL JAR under table top  
prevents soiling materials  
or operator's clothing.

We Use and Recommend G. E. Motors



## **USE ONLY GENUINE BONIS NEEDLES and PARTS**



It is imperative to use Genuine Bonis Needles **ONLY**. Perfected by intensive research, they have been designed and made especially for Bonis Machines; precision made with the proper temper and smooth eye. They are also the exact length and perfect fit to produce maximum efficiency in sewing heavy or fine work. They eliminate skipping of stitches; needle and thread breakage.

GENUINE BONIS MACHINE PARTS are equally important. It is not possible to put old parts into a new type machine and make it work right. All Bonis machines and their parts are meticulously manufactured in our own plant under the supervision of fully skilled mechanics and sold by us or our authorized Bonis agents. These agents are located in all important cities of the U. S. and Europe. They are equipped to give you excellent sales and service. **BE SURE** to order directly from our New York office or from one of these authentic agents.

**WHEN ORDERING PARTS YOU MUST STATE TYPE OF WORK FOR WHICH THEY ARE TO BE USED.**

## **VARIOUS TYPES OF BONIS SEWING MACHINES**

Bonis sewing machines are made in different models and types of models with very fine adjustments, guides and gauges to accommodate the needs of several different industries.

Model A is the recognized standard fur sewing machine used world wide throughout the industry. It is used for sewing very fine and medium heavy fur skins.

Model B comes in many different types. One with fine adjustments produces whip stitching used on gloves and kidskin products.

Model B is also used for heavier work, such as moutons, sheep skins and all heavy pelts and for closing heavy type furs.

Equipped with various gauges, the Model B machine is used in the millinery trade to insert wire in rims of ladies' hats.

Still another type of Model B is highly successful for even heavier duty work such as: sewing house slippers, taxidermy and all coarse work.

**THEREFORE IT IS ABSOLUTELY NECESSARY TO STATE THE TYPE OF WORK TO BE DONE WHEN ORDERING ANY MACHINE OR ITS PARTS AND NEEDLES.**

Model T machine has been perfected for extremely coarse work and comes in a variety of types.

Model T for the toy market will sew beautifully and efficiently on plush, plastics, vinyl, terry cloth, or any other tough fabric.

In different types, it is used to sew handles on luggage, robe straps in automobiles, ear laps on caps and on many styles of house slippers.

# TO SET UP MACHINE

To set up any Bonis machine, whether on a power table or individual stand, remove the old type plate and replace it with a genuine Bonis base plate which contains an oil reservoir for drainage of oil into the oil jar attached under the stand.

Place base plate on the table with the large hole in base plate to the right so that the two belt holes in table top will be to the right of the base plate. DO NOT PLACE SCREWS YET, first, put machine in place on the base plate and line up machine belt with motor. Put belt over wheel so that belt is free from table top slots and belt will move freely. Line up plate and machine to favor belt holes. Base plate must be set two inches back from front edge for sewing furs and cloth. However, when sewing toys, the plate is set **flush** with front of table; and for sewing gloves, it is set one inch back.

When lined up properly, mark position of plate on table with pencil and remove machine head. Note that there are two holes in plate; the old chain hole will correspond with new one, but at upper left corner of plate is an oil drainage hole. Mark this with pencil on old table, as a drainage hole must be drilled in table top. Before drilling this hole, drop chain lever on the side. Now take plate off and drill one inch wood drill through table top. Replace plate on table and see that all holes in plate and table correspond. Fasten base plate firmly to table with four wood screws. Now place machine on base plate.

## - CAUTION -

Sometimes a table top is slightly warped. Caution must be used that machine does not bind because of this. To guard against this binding, see that machine is perfectly firm on the base plate; if it rocks at all, or if there is any play in the corners, it is certainly advisable to remove the machine head and mark the corner where it is **not** steady. Loosen four wood screws a few turns and force two or three thicknesses of paper under the **plate** so that base plate is level. Replace machine head.

Now put chain through chain hole, fasten head firmly to plate with four machine screws and turn hand wheel so that it is free without any binding; now put on belt.

Put jar holder into oil jar hole and screw into plate. Leave thumb spring toward back of the stand — this position is most important, because the next step is installation of the chain lever . . . Set chain lever at bottom where it is free from the oil jar. Hook chain into lever, now try foot pedal to see that chain works properly without any obstruction. It is important to squeeze chain link into the lever so that it will not come out easily, because should this work loose, it will cause wheel beakage. Make sure there is leverage in left foot pedal to work machine arm freely.

The best way of tightening chain to lever . . . open arm with left foot pedal and wedge either a screw driver or piece of wood so that arm stays open; then close hook into the lever. Before removing wedge, take foot, open arm, then remove wedge and, by holding arm, let it return to position **very** slowly, or you will break wheel discs.

## OILING

The life of any sewing machine is proper lubrication to insure easy running and prevent unnecessary wear of movable parts.

The diagram illustrates where to oil.

It is not advisable to use light oil such as is used in house sewing machines. Bonis machines are used for hard work and require an oil with more body; they will function most satisfactorily with #30 or #40 weight motor oil.

For best results, it is essential to oil the machine twice a day before starting work in the morning and also at midday.

## TO SET THE NEEDLE

Turn the belt wheel until the looper swings out of the way and open the feed discs.

With tweezers, hold the needle with short groove up; place it into needle groove in the needle bar slot where clamp holds it and **push it back as far as it will go**. Tighten the clamp screw.

Never release the needle clamp more than is necessary to free the needle, and, before inserting the needle, make sure there is no piece of a broken needle left in the groove.

**CAUTION:** It is essential that short groove of needle faces upwards and long groove on the under side. If placed in the reverse manner, the machine will not sew properly; it will skip, so, before placing needle, check the position of needle grooves and then that needle is all the way into stopper of needle bar.

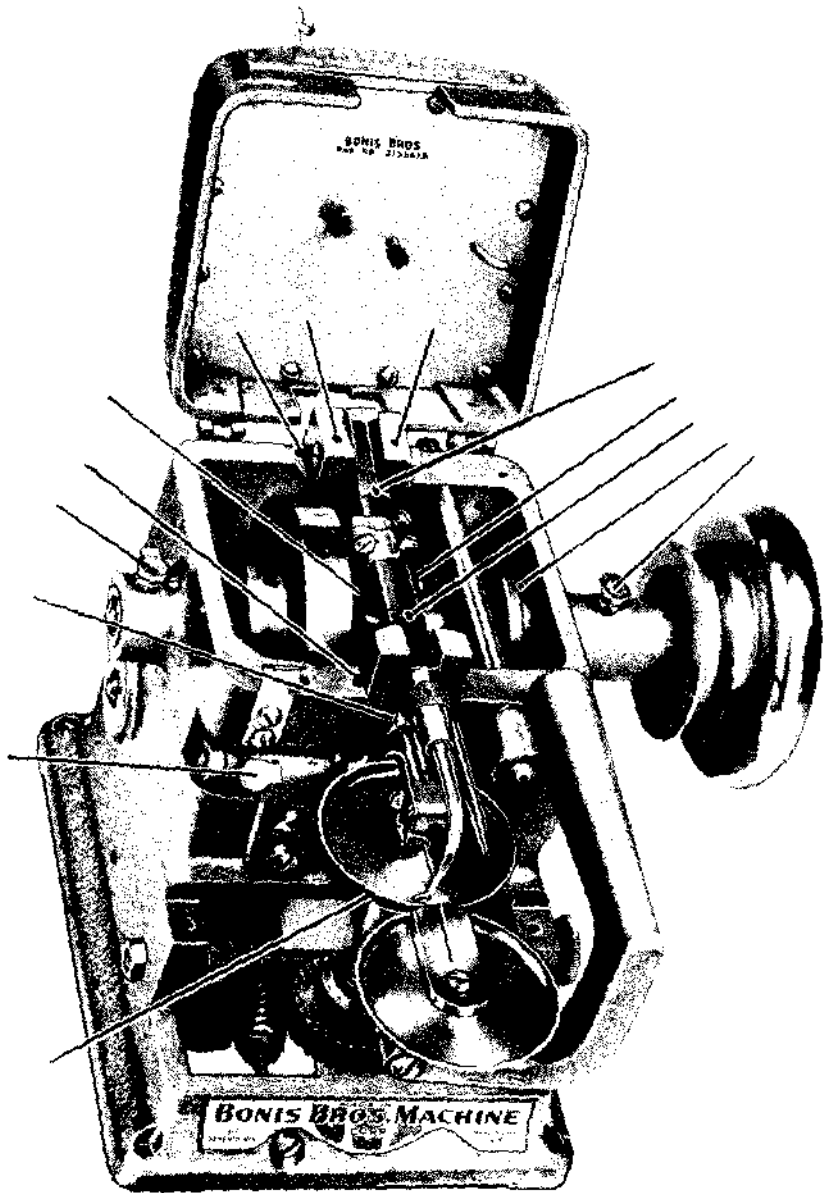

## OILING

BE SURE TO PUT OIL IN COVER WHERE  
INDICATED-ON KNOB ON TOP OF COVER