

CLINTON SERVICE GUIDE

MODEL 200FCA-C

FOR

JUKI MO2300, MO2400, MO2500

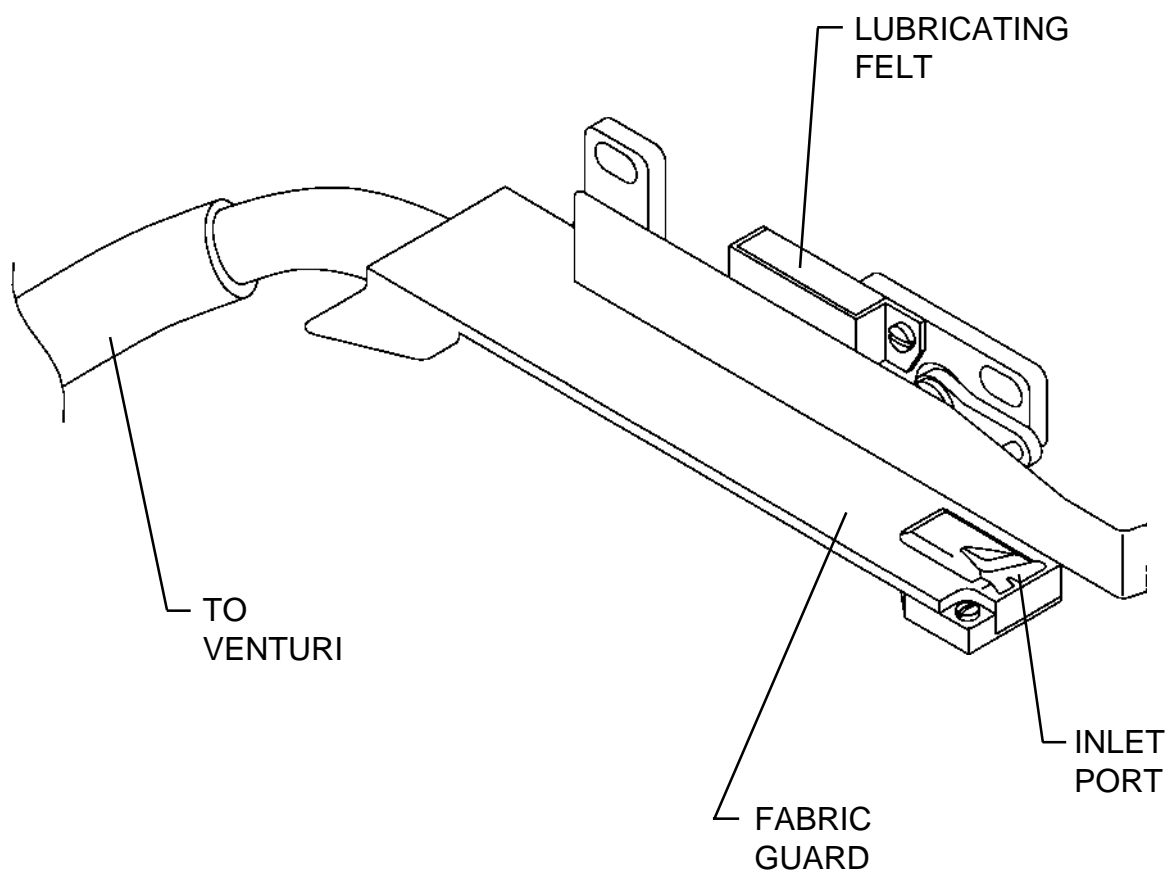

Clinton Industries, Inc.
700 Washington Ave.
Carlstadt, N.J. 07072
Phone: 201-935-4242
Fax: 201-935-3615
Web Site: <http://www.clintonind.com>
Email: general@clintonind.com

200FCA-C CUTTER ASSEMBLY JUKI MO2300, MO2400, MO2500

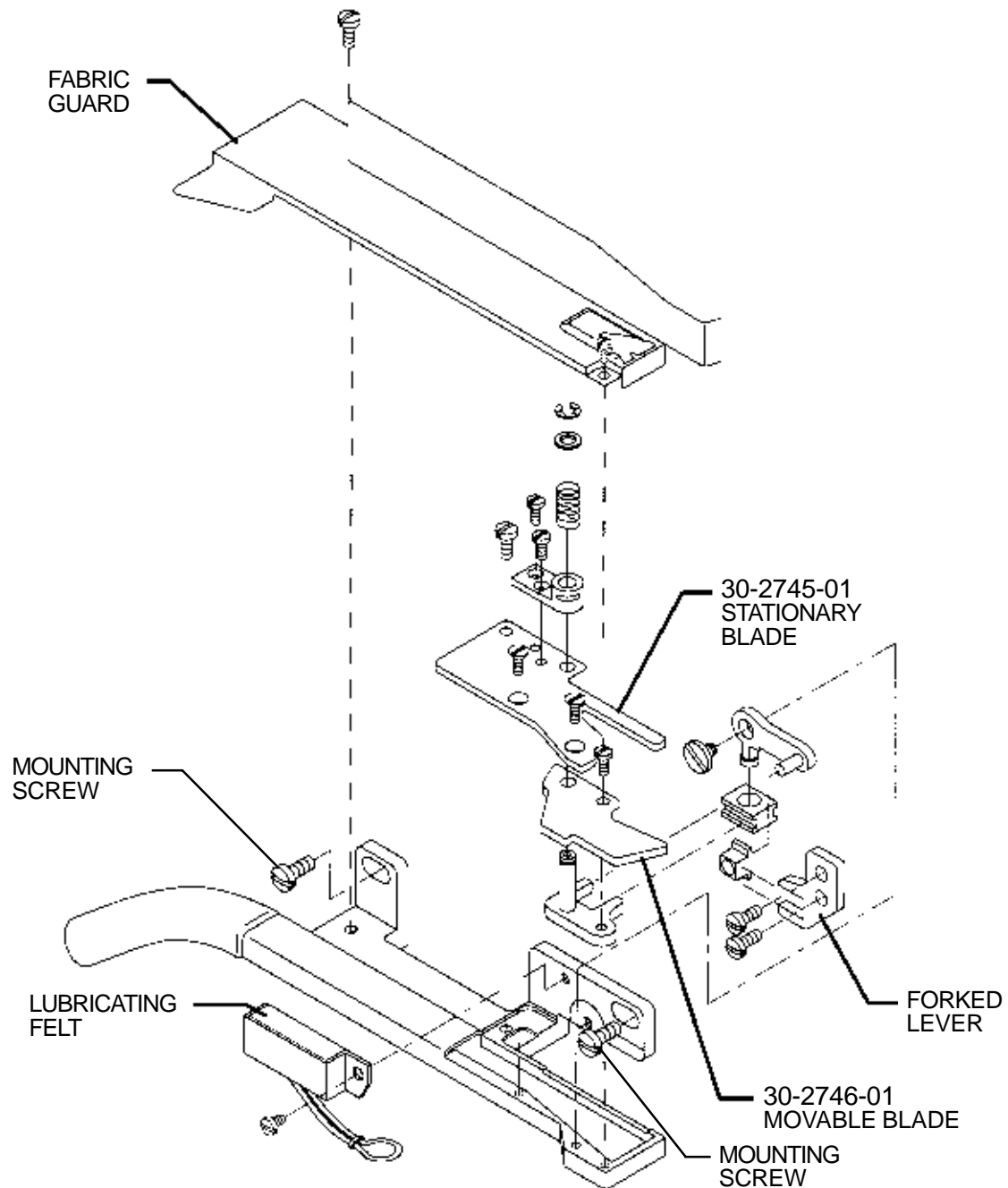

INSTALLATION:

1. MOUNT THE UNIT ON MACHINE.
2. ADJUST THE KNIFE STROKE BY ADJUSTING THE FORKED LEVER.
3. FILL THE LUBRICATING FELT WITH OIL. MOUNT THE FABRIC GUARD.

INSTALACION:

1. COLOQUE EL CORTADOR EN LA MAQUINA COMO SE MUESTRA ARRIBA.
2. AJUSTE LA CARRERA DE LA CUCHILLA MEDIANTE EL AJUSTE DE LA PALANCA BIFURCADA (FORKED LEVER).
3. LLENE EL FIELTRO LUBRICADOR CON ACEITE. COLOQUE EL GUARDA TELA.