

CONSEW *Since 1898*
CONSOLIDATED SEWING MACHINE CORP.
└ INDUSTRIAL SEWING & CUTTING EQUIPMENT

PARTS LIST

206RBL-30

CONSEW *Since 1898*
CONSOLIDATED SEWING MACHINE CORP.
└ INDUSTRIAL SEWING & CUTTING EQUIPMENT

400 VETERANS BLVD, CARLSTADT, NJ 07072

INDEX

PERSPECTIVE.....	1
THREAD TENSION, GUIDE, NEEDLE PLATE.....	2, 3
ARM SHAFT, TAKE UP LEVER.....	4, 5
NEEDLE BAR, FEEDING MECHANISM.....	6, 7
PRESSER BAR.....	8, 9
LOWER FEEDING MECHANISM.....	10, 11
FEED REGULATOR.....	12, 13
ARM SHAFT (UPRIGHT), LOWER SHAFT.....	14, 15
ACCESSORIES.....	16, 17
HOOK.....	18, 19
BELT GUARD.....	18, 19

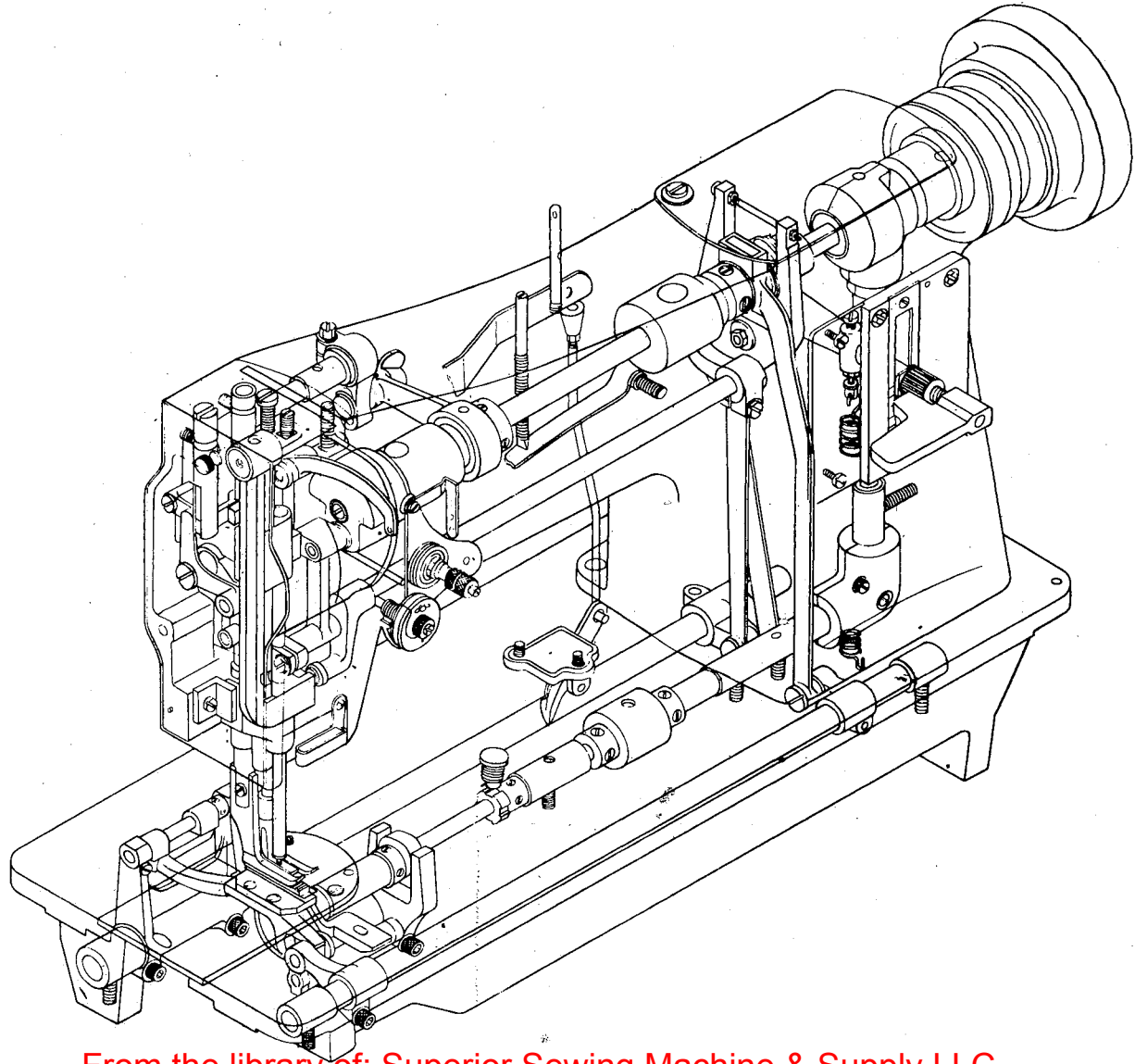

From the library of: Superior Sewing Machine & Supply LLC

2 THREAD TENSION, GUIDE, NEEDLE PLATE

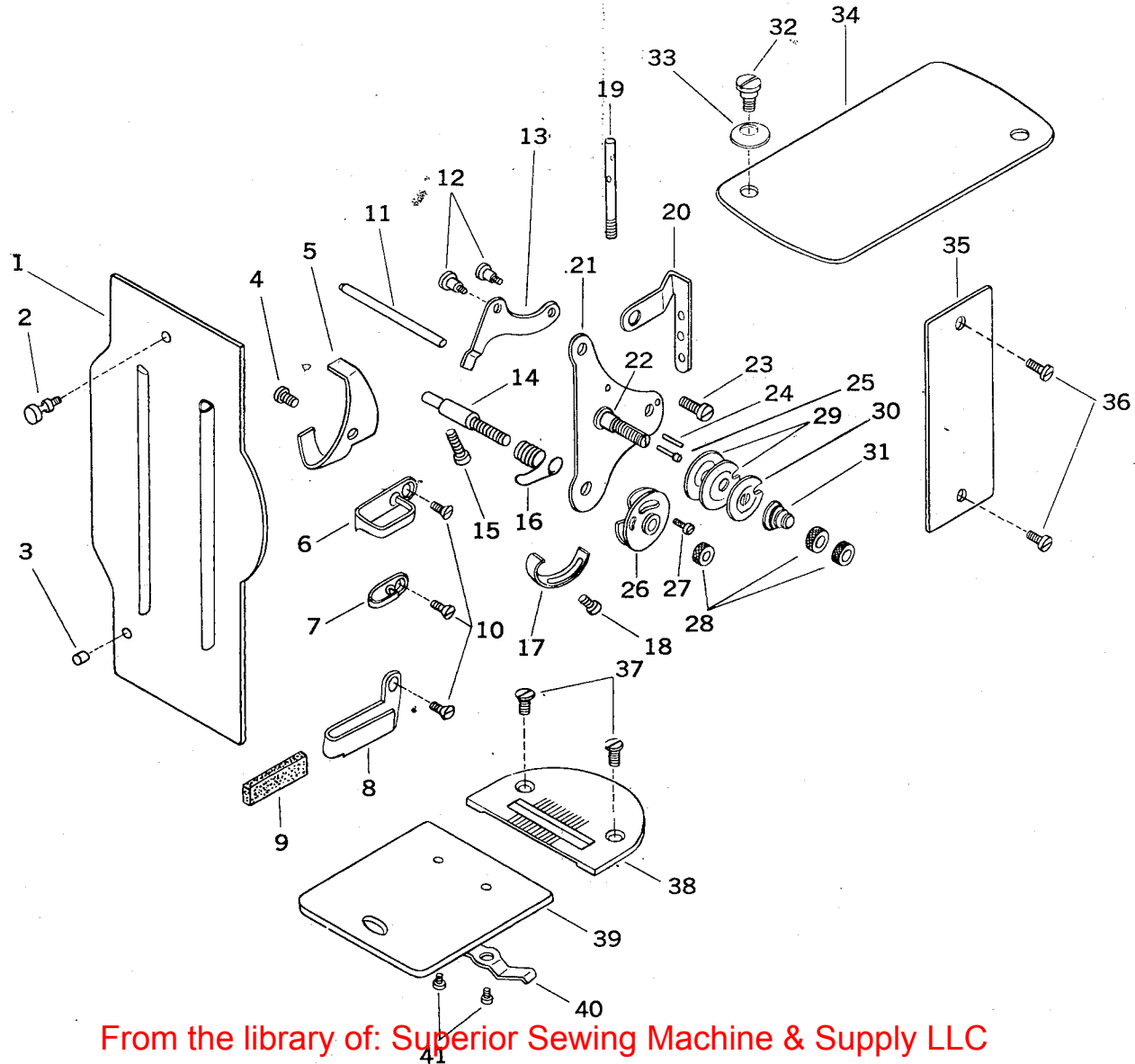

From the library of: Superior Sewing Machine & Supply LLC

THREAD TENSION, GUIDE, NEEDLE PLATE

Fig. No.	Parts No.	Quantity	Name of Parts
1	10698	1	Face plate
2	10699	1	Face plate set screw
3	10700	1	Face plate stopper pin
4	10650	1	Screw for #10551
5	10551	1	Needle bar connecting link oil guard
6	10682	1	Thread guide (upper)
7	10683	1	Thread guide (middle)
8	10759	1	Thread guide (lower)
9	10760	1	Felt for thread guide
10	10685	3	Thread guide screw
11	10720	1	Tension release lever rod
12	10679	2	Tension release lever screw
13	10678	1	Tension release lever
14	10792	1	Thread controller stud
15	10545	1	Tension stud set screw
16	10689	1	Thread controller spring
17	10690	1	Thread controller spring stop
18	10650	1	Set screw for #10690
19	10709	1	Spool pin
20	15062	1	Thread retainer
21	10675	1	Tension bracket

Fig. No.	Parts No.	Quantity	Name of Parts
22	10789	1	Tension stud
23	15055	1	Set screw for #10675
24	10791	1	Tension bracket pin
25	10793	1	Tension release plunger
26	10694	1	Thread controller disc
27	10695	1	Thread controller disc screw
28	10697	3	Tension thumb nut
29	10691	2	Thread disc
30	10692	1	Tension release washer
31	10693	1	Tension release spring
32	10704	1	Arm cap screw
33	10703	1	Arm cap screw washer
34	18004	1	Arm cap
35	18005	1	Arm side cover
36	8100	2	Set screw for #18005
37	6031	2	Needle plate set screw
38	18030	1	Needle plate
39	18032	1	Bed slide
40	6034	1	Bed slide spring
41	6035	2	Set screw for #6034

ARM SHAFT, TAKE UP LEVER

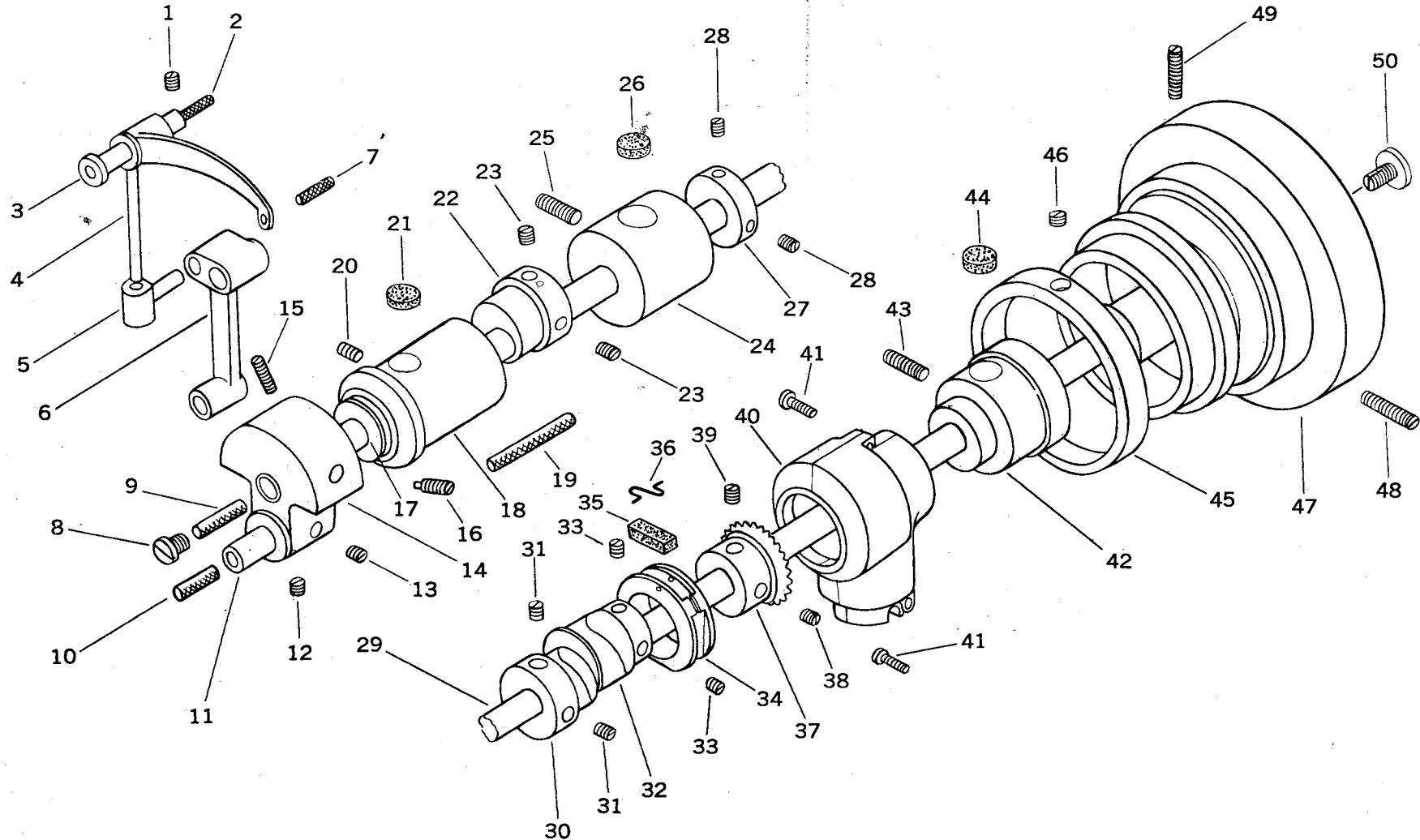

ARM SHAFT, TAKE UP LEVER

Fig. No.	Parts No.	Quantity	Name of Parts
1	10571	1	Set screw for #10527
2	10726	1	Oil wick for #10527
3	10527	1	Take up lever hinged stud
4	18003	1	Thread take up lever
5	15026	1	Take up lever driving stud
6	10528	1	Needle bar connecting link
7	10728	1	Oil wick for #15026
8	10506	1	Arm shaft oil packing stop screw
9	10724	1	Oiling wick for arm shaft
10	10726	1	Oiling wick for #10523
11	10523	1	Needle bar connecting link stud
12	10764	1	Set screw (B) for #10523
13	10524	1	Set screw (A) for #10523
14	10520	1	Needle bar crank
15	10522	1	Screw (B) for #10520
16	10521	1	Screw (A) for #10520
17	10563	1	Arm shaft bushing (front) washer
18	18006	1	Arm shaft bushing (front)
19	10729	1	Oil wick for #18006
20	10522	1	Set screw for #18006
21	10725	2	Oiling felt for #18006
22	10771	1	Lifting eccentric
23	10566	2	Screw for #10771
24	18008	1	Arm shaft bushing (middle)
25	10571	1	Set screw for #18008

Fig. No.	Parts No.	Quantity	Name of Parts
26	10725	1	Oiling felt for #18008
27	17014	1	Arm shaft bushing collar
28	10766	2	Set screw for #17014
29	17011	1	Arm shaft
30	18020	1	Feed lifting cam
31	10766	2	Set screw for #18020
32	18009	1	Feed driving eccentric
33	10766	2	Set screw for #18009
34	17040	1	Feed fork collar
35	17041	1	Oiling felt for #17040
36	10723	1	Oiling felt presser pin
37	17017	1	Arm shaft gear (spiral)
38	17018	1	Set screw (A) for #17017
39	17019	1	Set screw (B) for #17017
40	17015	1	Gear cover (upper)
41	17016	2	Set screw for #17015
42	17013	1	Arm shaft bushing (rear)
43	10571	1	Set screw for #17013
44	13081	1	Oiling felt for #17013
45	13423-B	1	Stitch length indicator
46	10566	1	Set screw for #13423-B
47	10504	1	Balance wheel
48	10576	1	Set screw (A) for #10504
49	10579	1	Set screw (B) for #10504
50	10577	1	Balance wheel adjusting screw

NEEDLE BAR, FEEDING MECHANISM

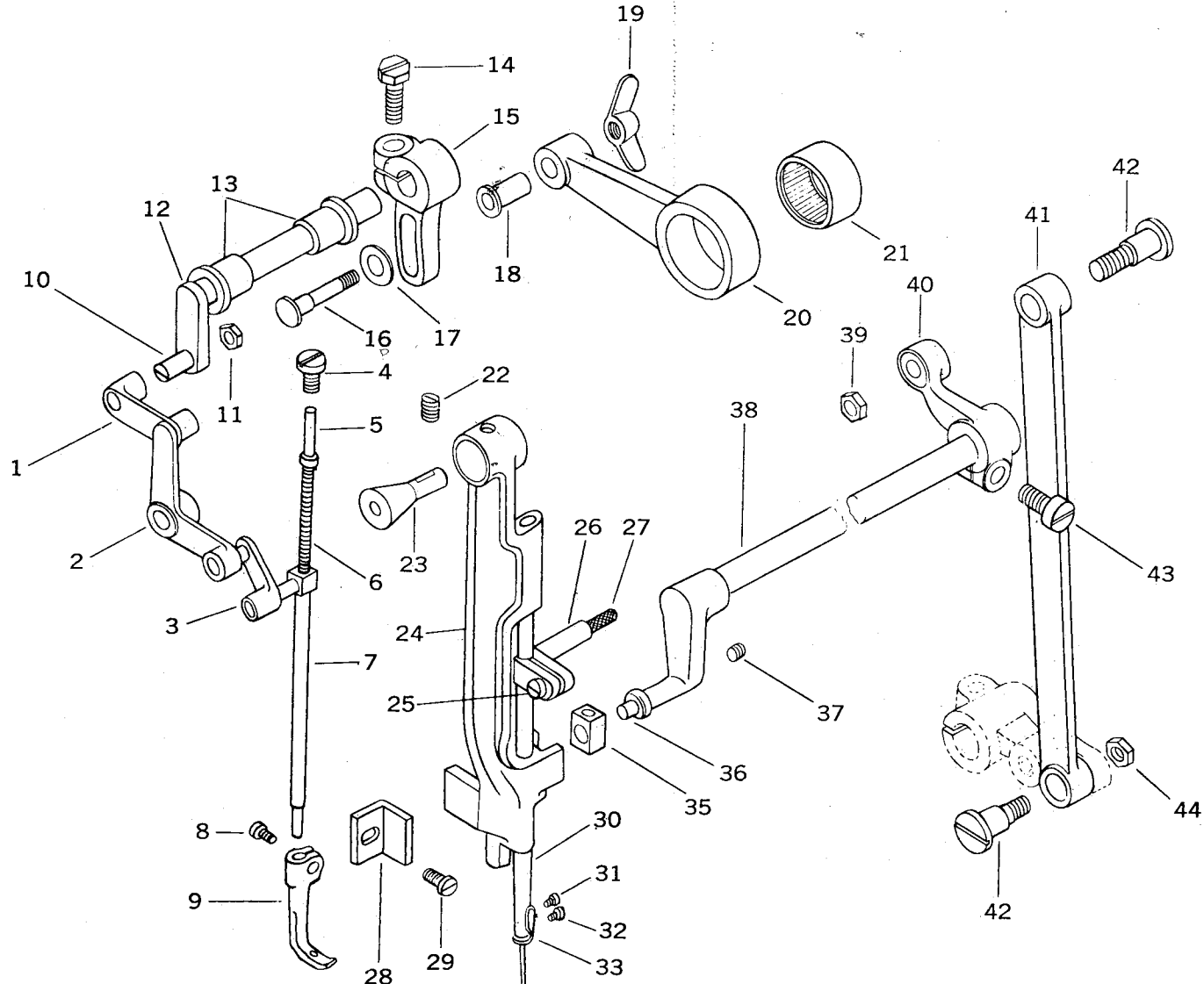

NEEDLE BAR, FEEDING MECHANISM

Fig. No.	Parts No.	Quantity	Name of Parts
1	10557	1	Lifting bell crank link
2	10558	1	Lifting bell crank
3	10556	1	Vibrating presser bar connecting link
4	15060	1	Screw for #10555
5	10553	1	Vibrating presser bar extension
6	10554	1	Vibrating presser bar extension spring
7	10555	1	Vibrating presser bar
8	10662	1	Vibrating presser foot pinch screw
9	10795	1	Vibrating presser foot
10	10519	1	Screw for #10515
11	10517	1	Nut for #10519
12	10515	1	Lifting rock shaft
13	10514	2	Lifting rock shaft bushing
14	10754	1	Clamp screw for #10751
15	10751	1	Lifting eccentric connecting crank
16	10775	1	Screw for #10774
17	10703	1	Washer for #10774
18	10774	1	Lifting eccentric connecting collar
19	10776	1	Wing nut for #10772
20	10772	1	Lifting eccentric connection
21	10773	1	Needle bearing for #10772
22	10525	1	Screw for #10536

Fig. No.	Parts No.	Quantity	Name of Parts
23	20103	1	Needle bar rock frame hinged stud
24	10536	1	Needle bar rock frame
25	10532	1	Set screw for #10531
26	10531	1	Needle bar connecting stud
27	10726	1	Oil wick for #10531
28	10560	1	Needle bar rock frame position bracket
29	10561	1	Set screw for #10560
30	10530	1	Needle bar
31	10534	1	Set screw for #10533
32	10535	1	Needle set screw
33	10533	1	Needle bar thread guide
34	6332	1	Needle DPx17 #22
35	10582	1	Needle bar rock frame slide block
36	10580	1	Needle bar rock frame slide block stud
37	10581	1	Screw for #17048
38	17048	1	Needle bar rock frame rock shaft
39	6026	1	Nut (upper) for #18017
40	18016	1	Needle bar rock frame rock shaft crank
41	18017	1	Needle bar rock frame rock shaft crank connection
42	18018	2	Hinge screw for #18017
43	10519	1	Set screw for #18016
44	8105	1	Nut for #18018

PRESSER BAR

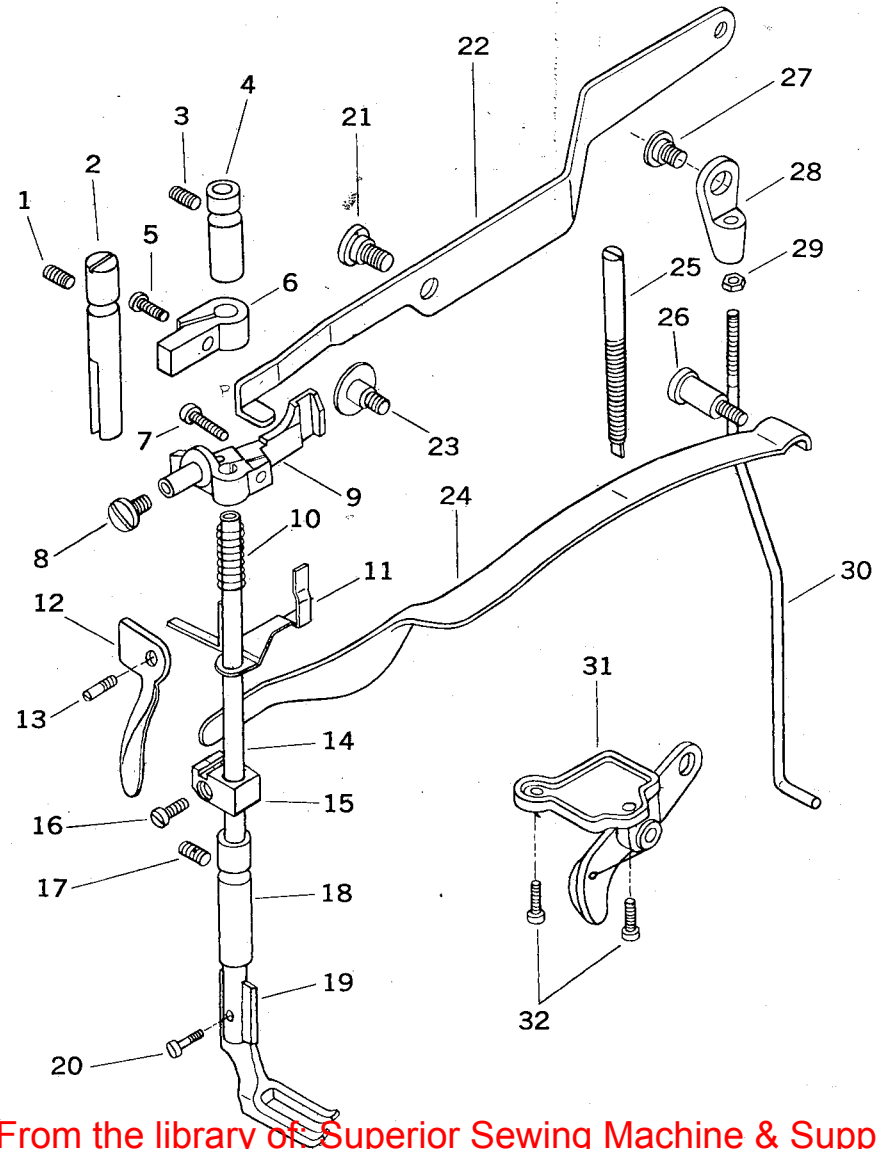

From the library of Superior Sewing Machine & Supply LLC

PRESSER BAR

Fig. No.	Parts No.	Quantity	Name of Parts
1	10761	1	Set screw for #10543
2	10543	1	Presser bar position guide
3	10761	1	Set screw for #10538
4	10538	1	Presser bar bushing (upper)
5	10662	1	Pinch screw for #10543
6	10541	1	Presser bar position guide bracket
7	10545	1	Screw for #10544
8	10559	1	Set screw for #10558
9	10544	1	Presser bar lifting bracket
10	10547	1	Tension release spring
11	10546	1	Tension release slide
12	10659	1	Presser bar lifter
13	10660	1	Hinge screw for #10659
14	10540	1	Presser bar
15	10549	1	Presser bar spring bracket
16	10532	1	Pinch screw for #10549

Fig. No.	Parts. No.	Quantity	Name of Parts
17	10761	1	Set screw for #10531
18	10531	1	Presser bar bushing (lower)
19	10796	1	Lifting presser foot
20	10664	1	Pinch screw for #10796
21	10712	1	Set screw for #18080
22	18080	1	Knee lifter lifting lever
23	10548	1	Presser bar lifting bracket guide screw
24	10705	1	Presser bar spring (flat)
25	11156	1	Presser bar spring (flat) regulating screw
26	10706	1	Presser bar spring (flat) supporting screw
27	6394	1	Hinge screw for #6359
28	6359	1	Knee lifter lifting lever connecting rod joint
29	6360	1	Knee lifter lifting lever connecting rod screw
30	18081	1	Knee lifter lifting lever connecting rod
31	18082	1	Knee lifter bell crank complete
32	18085	2	Set screw for Knee lifter bell crank complete

10 LOWER FEEDING MECHANISM

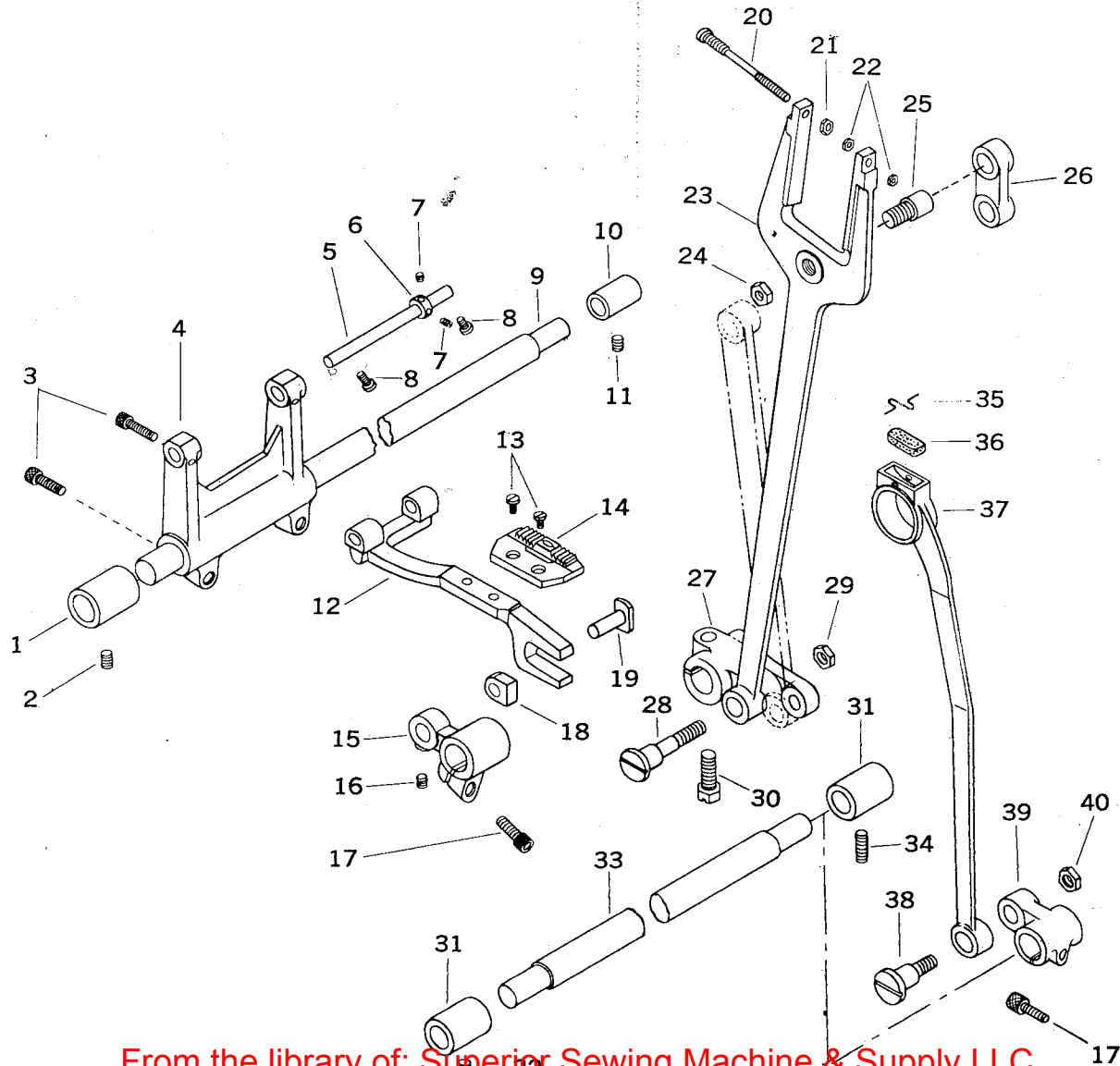

LOWER FEEDING MECHANISM

Fig. No.	Parts No.	Quantity	Name of Parts
1	18062	1	Feed rock shaft bushing (front)
2	8009	1	Set screw for #18062
3	18065	2	Set screw for #18065
4	18064	1	Feed rock shaft base
5	18067	1	Feed base supporting pin
6	18068	1	Feed base supporting pin collar
7	8103	2	Set screw for #18068
8	21104	2	Set screw for #18067
9	18061	1	Feed rock shaft
10	18063	1	Feed rock shaft bushing (rear)
11	21124	1	Set screw for #18063
12	18066	1	Feed base
13	8044	2	Feed dog screw
14	18031	1	Feed dog (Standard type)
15	18074	1	Feed lifting rock shaft front bell crank
16	2067	1	Set screw for #18075
17	18065	2	Set screw for feed lifting rock shaft bell crank
18	18075	1	Feed lifting rock shaft slide block
19	18076	1	Pin for #18075
20	18011	1	Set screw for #18010

Fig. No.	Parts No.	Quantity	Name of Parts
21	4137	1	Nut (big) for #18010
22	4211	2	Nut (small) for #18010
23	18010	1	Feed forked connection
24	8105	1	Nut for #18010
25	18014	1	Hinge screw for #18010
26	17207	1	Feed connecting link
27	18070	1	Feed rock shaft bell crank (Back)
28	18015	1	Hinge screw for #18010
29	8105	1	Nut for #18010
30	10754	1	Pinch screw for #18070
31	18073	2	Feed lifting rock shaft bushing
32	8009	1	Set screw (front) for #18073
33	18072	1	Feed lifting rock shaft
34	10579	1	Set screw (rear) for #18073
35	10723	1	Oiling felt presser pin
36	17041	1	Oiling felt for #18021
37	18021	1	Crank connecting rod
38	18018	1	Hinge screw for #18021
39	18077	1	Feed lifting rock shaft bell crank (back)
40	8105	1	Nut for #18018

FEED REGULATOR

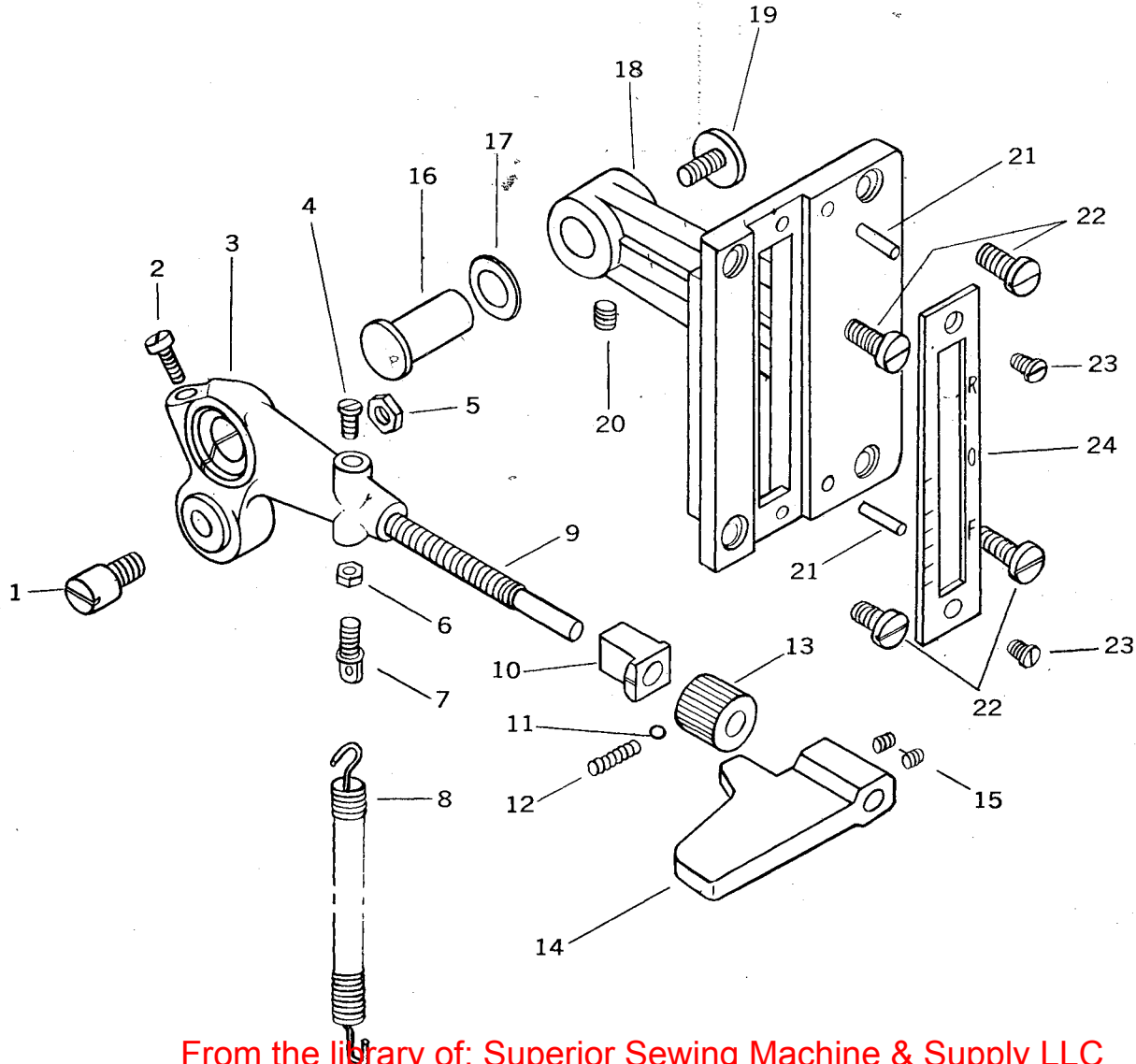

From the library of: Superior Sewing Machine & Supply LLC

FEED REGULATOR

Fig. No.	Parts No.	Quantity	Name of Parts
1	17209	1	Feed regulating screw
2	17053	1	Set screw for #18022
3	18022	1	Feed regulator
4	4019	1	Set screw for #18025
5	8105	1	Nut for #18025
6	4135	1	Nut for #18026
7	17059	1	Screw for #18026
8	18026	1	Feed regulating lever spring
9	18025	1	Feed regulating lever
10	13417	1	Feed adjusting pipe
11	8158	1	Bearing ball 1/8"
12	8157	1	Spring for #8158
13	13416	1	Feed adjusting knurling tool
14	18027	1	Reverse stitch lever
15	18028	2	Screw (small) for #18027
16	17055	1	Feed regulating support stud
17	17057	1	Washer for #17055
18	18023	1	Feed regulating base
19	1368	1	Supporting stud pushing screw
20	17056	1	Screw for #18023
21	50174	2	Pin for #18023
22	12361	4	Screw for #18023
23	17093	2	Set screw for #18024
24	18024	1	Stitch length indicating plate

14 ARM SHAFT (UPRIGHT), LOWER SHAFT

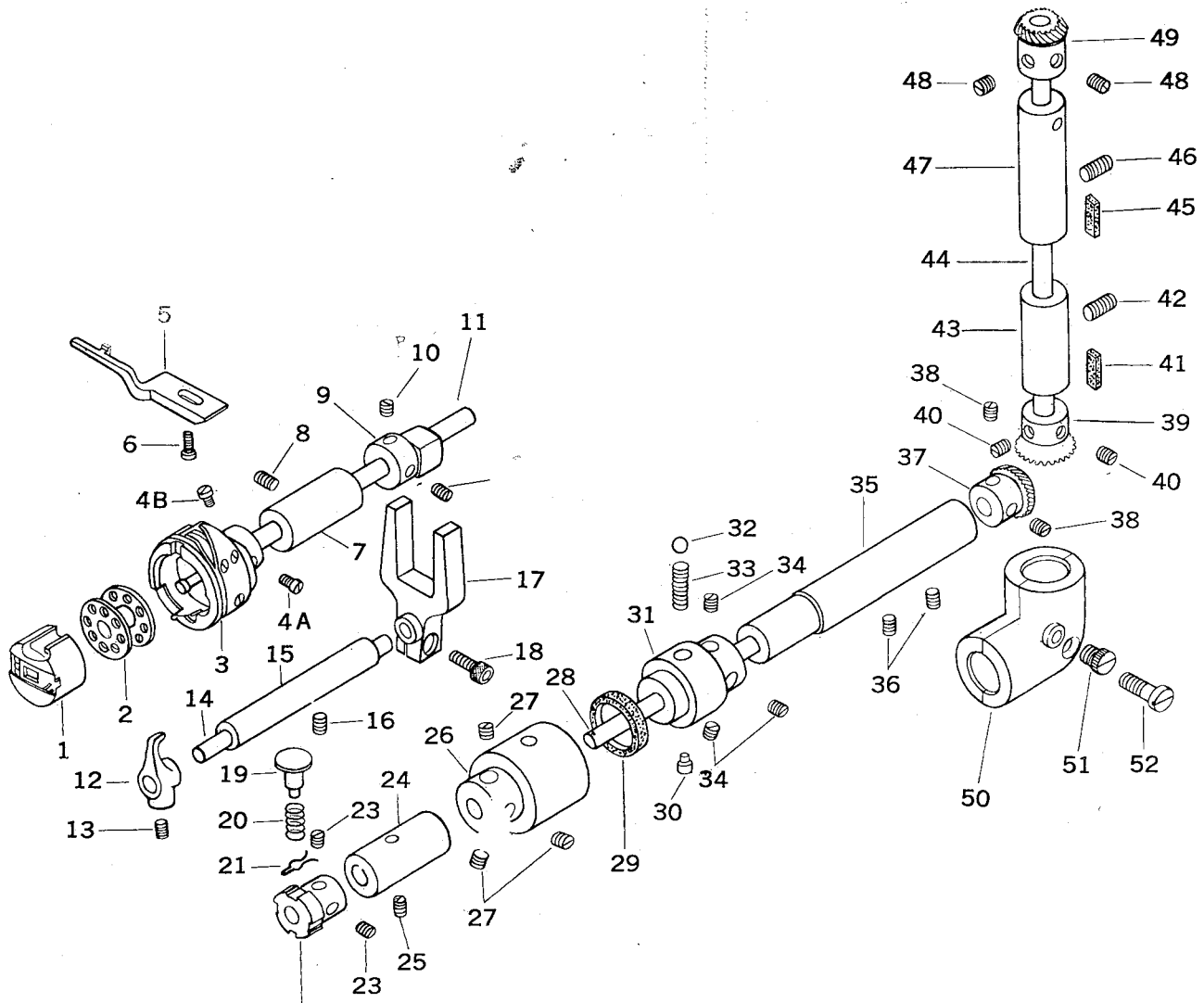

From the library of: Superior Sewing Machine & Supply LLC

ARM SHAFT (UPRIGHT), LOWER SHAFT

Fig. No.	Parts No.	Quantity	Name of Parts
1	18045	1	Bobbin case complete
2	18034	1	Bobbin
3	18033	1	Rotating hook complete
4A	18033-7	1	Hook set screw (A)
4B	18033-8	1	Hook set screw (B)
5	18035	1	Hook supporting plate
6	6025	1	Set screw for #18035
7	18037	1	Hook shaft bushing (front)
8	8009	1	Set screw for #18037
9	18044	1	Hook shaft collar
10	50304	2	Set screw for #18044
11	18036	1	Hook driving shaft
12	18039	1	Thread release finger
13	18040	1	Set screw for #18039
14	18041	1	Thread releasing shaft
15	18042	1	Thread releasing shaft bushing
16	21124	1	Set screw for #18042
17	18043	1	Thread releasing shaft fork
18	30066	1	Pinch screw for #18043
19	18053	1	Push button
20	18054	1	Push button spring
21	10674	1	Clip for #18033
22	18052	1	Hook shaft lock ratchet
23	17022	2	Set screw for #18052
24	18038	1	Hook shaft bushing (rear)
25	8009	1	Set screw for #18038
26	18047	1	Safety clutch (left)

Fig. No.	Parts No.	Quantity	Name of Parts
27	17019	3	Set screw for #18047
28	18056	1	Lower shaft
29	18046	1	Oil wick for #18047
30	18051	1	Set screw for #18050
31	18041	1	Safety clutch (right)
32	18049	1	Steel ball
33	18050	1	Spring for #18041
34	17019	3	Set screw for #18041
35	18057	1	Lower shaft bushing
36	8009	2	Set screw for #18057
37	17028	1	Lower shaft gear (spiral)
38	17022	2	Set screw for #17027
39	17023	1	Arm shaft (upright) gear (lower)
40	17022	2	Set screw for #17023
41	17026	1	Oiling felt for #17025
42	10571	1	Set screw for #17026
43	17025	1	Arm shaft (upright) bushing (lower)
44	17020	1	Arm shaft (upright)
45	17026	1	Oiling felt for #17024
46	10571	1	Set screw for #17026
47	17024	1	Arm shaft (upright) bushing (upper)
48	17022	2	Set screw for #17021
49	17021	1	Arm shaft (upright) gear (spiral)
50	18058	1	Gear cover complete (lower)
51	18060	1	Gear cover (lower) sealing screw
52	18059	1	Pinch screw for #18058

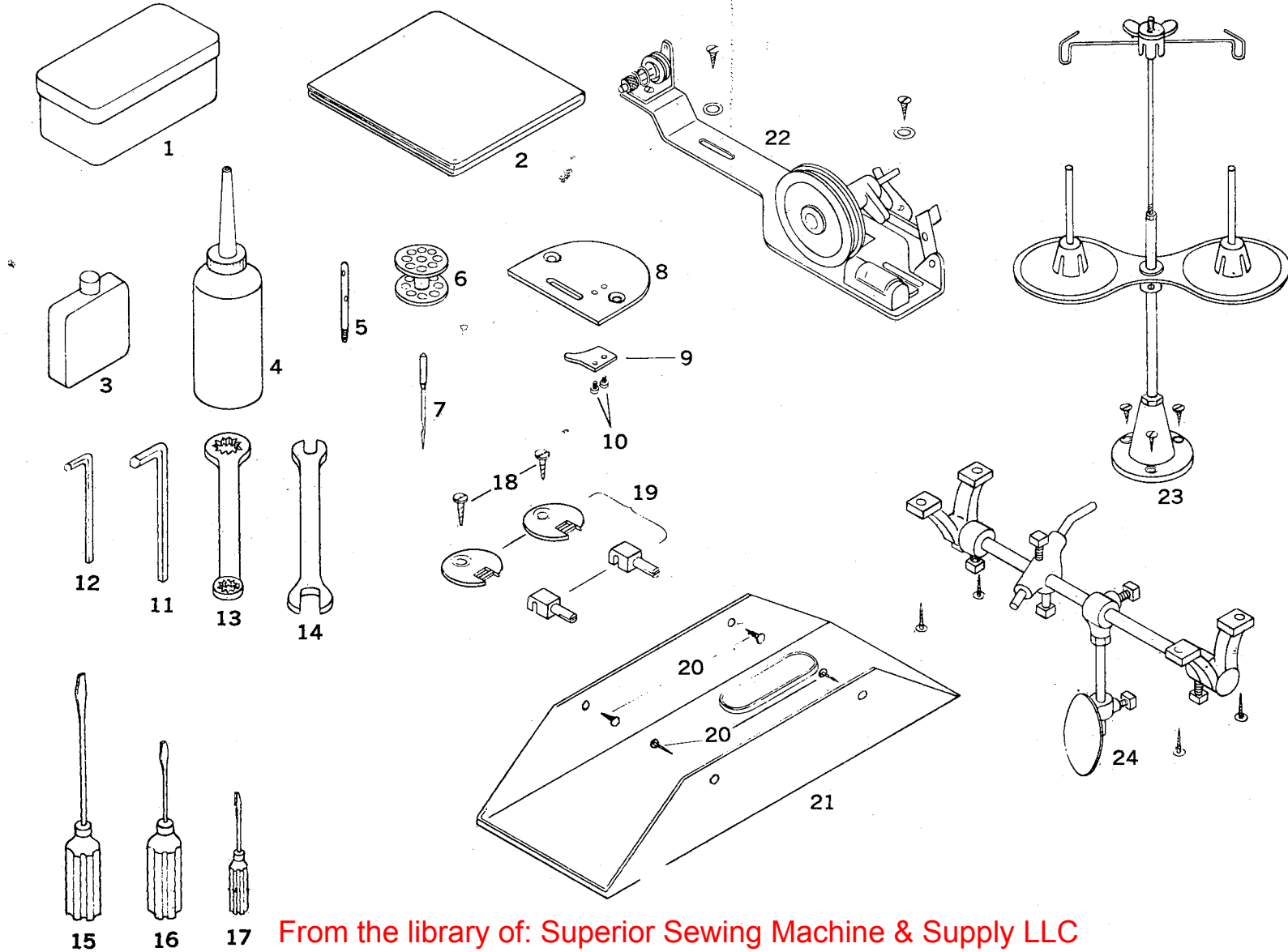

ACCESSORIES

Fig. No	Parts No.	Quantity	Name of Parts
1	8132	1	Accessories box
2	6057	1	Vinyl cover
3	8123	1	Oil
4	8125	1	Oiler
5	10709	1	Spool pin
6	18034	6	Bobbin
7	6332	3	Needle DPx17 #22
8	18029	1	Needle plate (for without lower feed)
9	2056	1	Needle plate spring
10	2063	2	Set screw for #2056
11	15571	1	Wrench 4.0mm
12	11969	1	Wrench 2.5mm
13	10748	1	Double head wrench
14	18084	1	Spanner 6×7mm
15	8118	1	Screw driver (large)
16	8120	1	Screw driver (middle)
17	8121	1	Screw driver (small)
18	6052	2	Screw for #6051
19	6051	2	Bed hinge connection
20	6055	4	Nail for #6054
21	6054	1	Oil pan
22	10734	1	Bobbin winder complete
23	10780	1	Thread stand
24	18038	1	Knee lifter complete

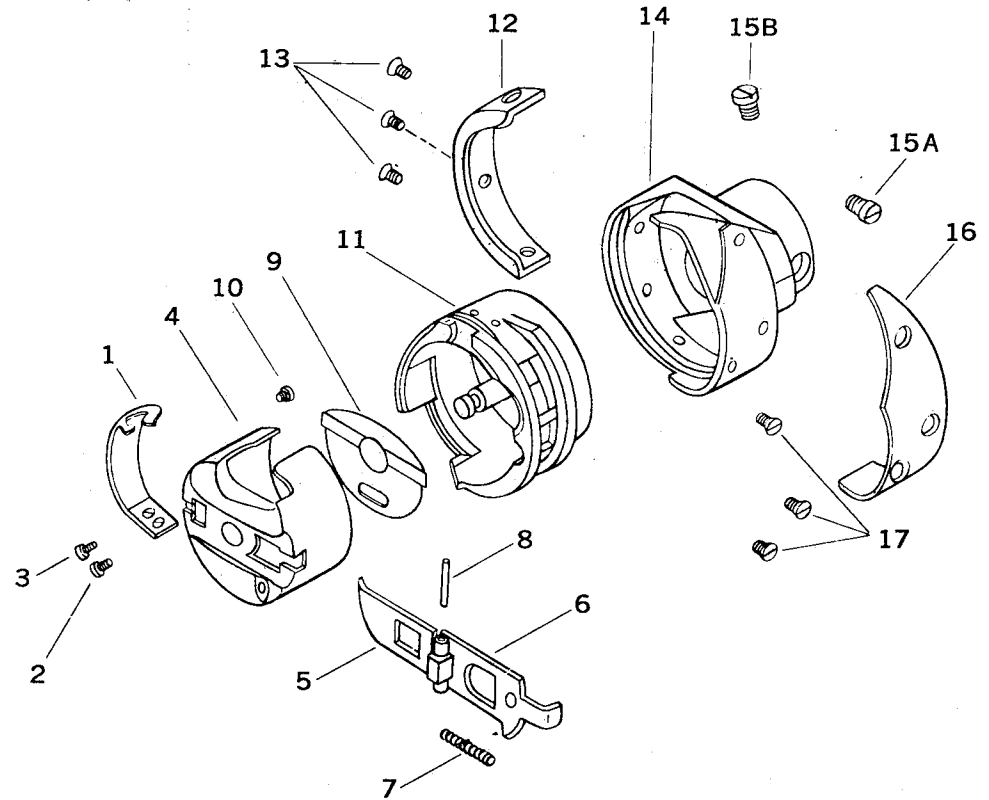
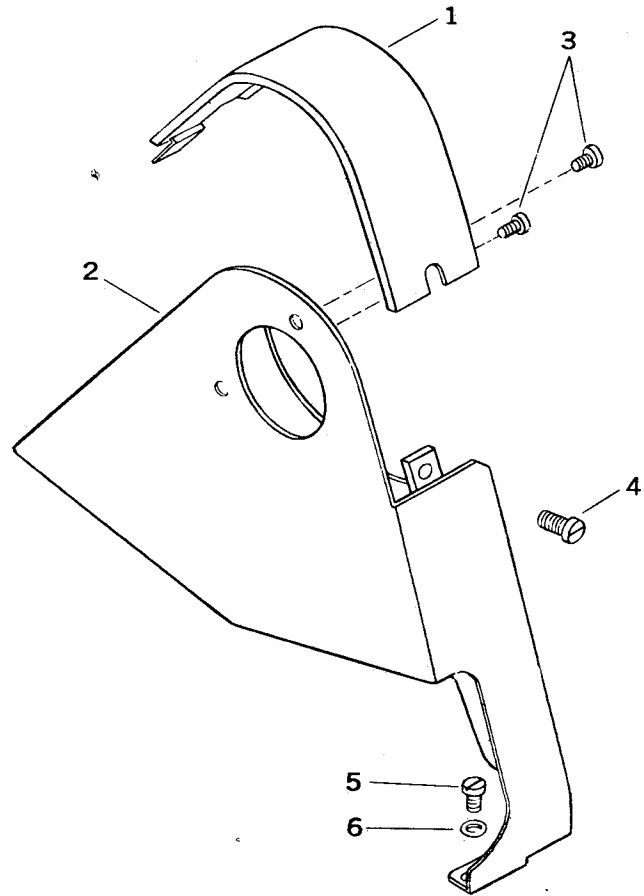

Fig. No.	Parts No.	Quantity	Name of Parts
1	15099	1	Belt guard upper cover
2	15098	1	Belt guard
3	10650	2	Set screw for #15098 (upper)
4	12481	1	Set screw for #15099
5	10650	1	Set screw for #15098 (lower)
6	11142	1	Washer for #10650

Fig. No.	Parts No.	Quantity	Name of Parts
1	18045- 2	1	Thread tension spring
2	18045- 4	1	Set screw for #18045-2
3	18045- 3	1	Thread tension spring regulating screw
4	18045- 1	1	Bobbin case
5	18045- 5	1	Bobbin case pulling plate
6	18045- 6	1	Bobbin set plate
7	18045- 8	1	Bobbin set plate spring
8	18045- 7	1	Pin for #18045-6
9	18045-10	1	Thread releasing protecting spring
10	18045- 9	1	Set screw for #18045-5
11	18033- 4	1	Bobbin case base
12	18033- 5	1	Hook gib
13	18033- 6	3	Set screw for #18033-5
14	18033- 1	1	Rotating hook only
15A	18033- 7	1	Hook set screw (A)
15B	18033- 8	1	Hook set screw (B)
16	18033- 2	1	Thread guide
17	18033- 3	3	Set screw for #18033-2