

# 5 2 5 N

## Instructions & Parts List

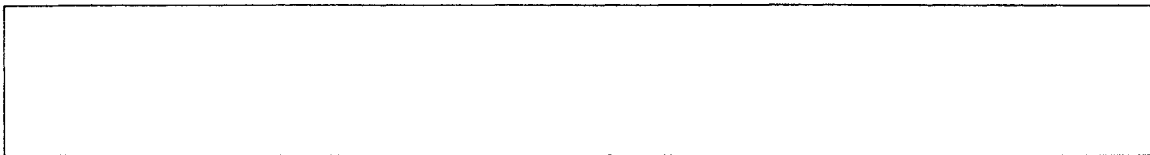

MODEL 525N

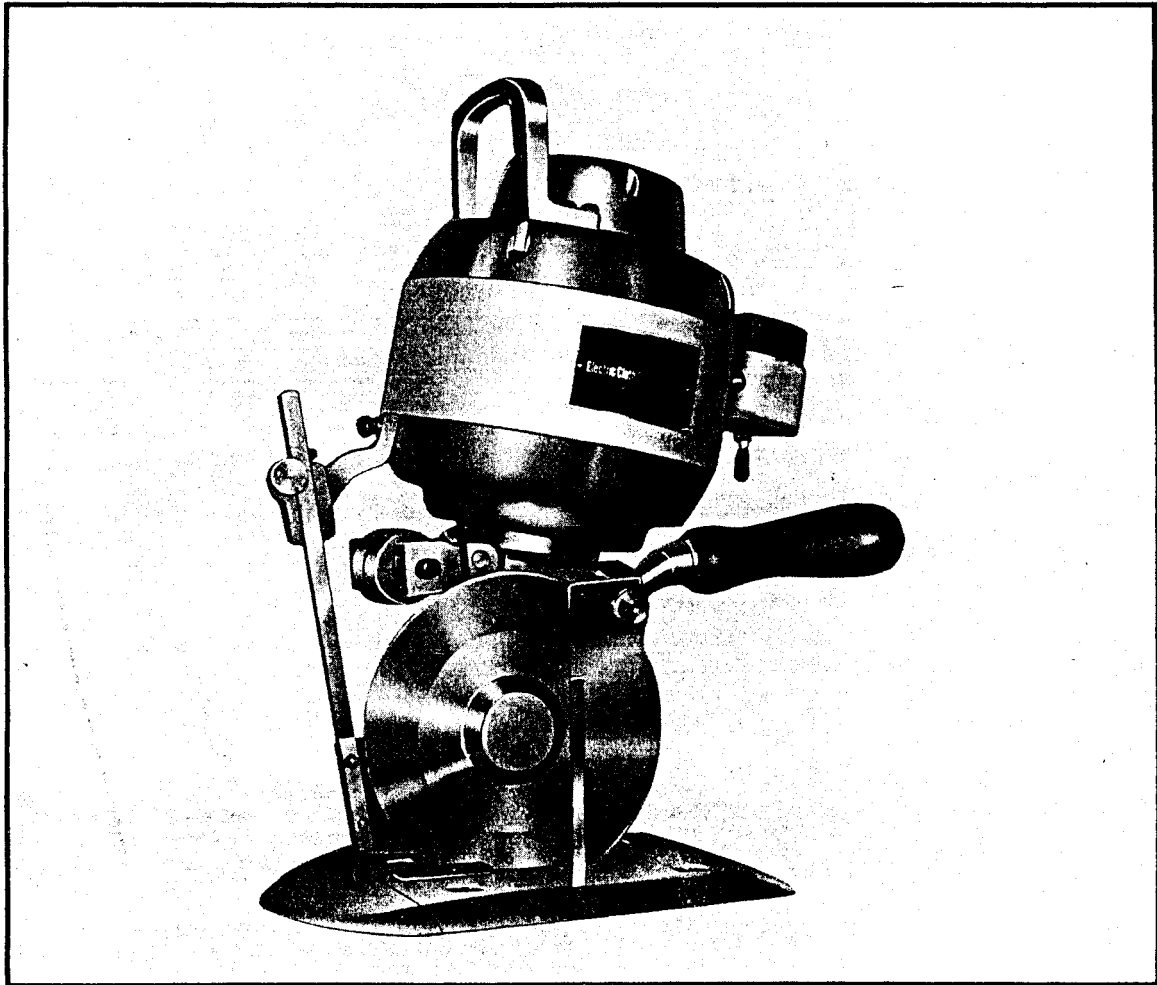
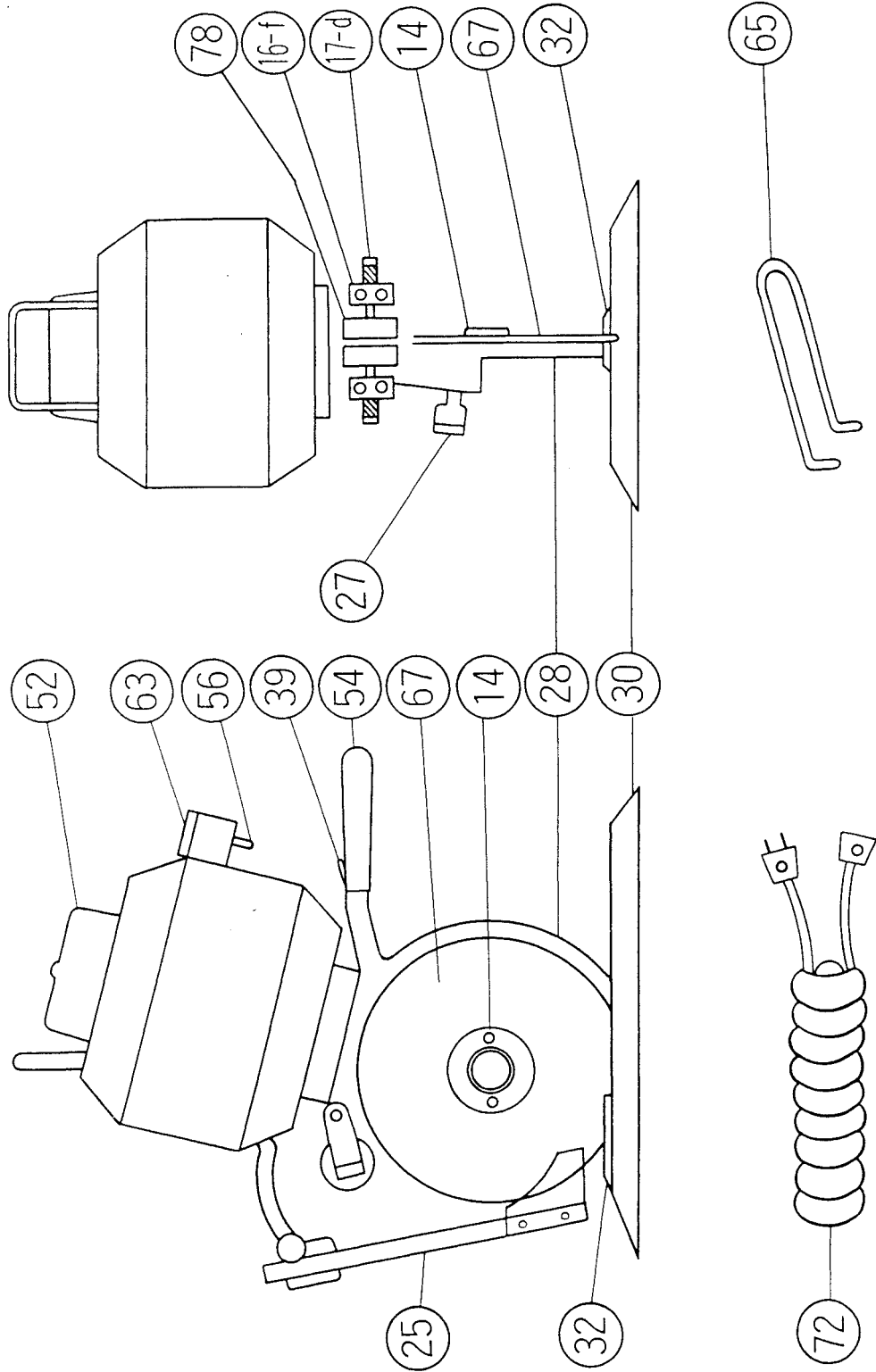

# INSTRUCTION BOOK FOR MODEL 525N

## 1. Starting.

Attach the operation handle (No.54) to the machine and after confirming that the switch (No.56) is at the "off" position, connect the electric cord (No.72) to the machine terminal end, and also connect the other end of the electric cord to the electric source. Taking away any foreign items, if any, from the machine bed (No.30), put the operation switch on to start the machine. **WARNING:** In case that the motor is three phases, direction of the rotation of the knife must be as indicated by arrow on the knife cover. If it rotates in the opposite direction, please reset the lead wires one another, excepting the green colored one, in the electric source plug.

## 2. Cutting operation.

Hold the operation handle and lift the knife guard (No.25). Put the materials in adequate thickness onto the machine bed. Then, start the cutting operation, pushing the machine forward to cut the material off.

## 3. Knife sharpening.

Keeping the motor running, lower the grinding lever (No.39) so the grinding stone (No.78) touches the knife (No.67) and keep it grinding for a few seconds. If the knife is so worn out, it needs more sharpening. Please repeat sharpening of it in the same way as often as it is necessary.

## 4. Knife replacement.

First, please be sure that the motor is not working. Then, make an adjustment of the knife and the position of the throat plate (No.32). If the knife is worn out, its cutting edge does not fit to the knife groove, and it has to be replaced. To remove the knife, insert the knife handle (No.65), which is one of the accessories, to the knife presser (No.14), and turn it counterclockwise. In case that the knife presser is connected too tightly, lock the small holes of the knife and the stand with a pin of about 4mm in diameter to stop the knife moving idle. To employ a new knife, align the knife to the key groove, facing its back side on to the stand. The knife has a front and back side. All other order to fit the knife is just the reverse sequence.

## 5. Sharpener adjustment and replacement.

After assuring that the motor is not working:

1) Loosen the grinder screws (No.16-f) so the grinder adjusting pipe screw (No.17-d) can move. Turn the grinder adjusting pipe screw by hand until the grinding stone almost touches the knife. Make the same adjustment to the other grinding stone, and tighten all the grinder screws. In the adjustment, the clearance between the right and left grinding stones should be maintained at about 1mm.

2) Remove the grinder screws (No.16-f), and take off the grinder setting studs. The grinding stones can be replaced with the new ones in the order that is a reverse sequence to their removing. The adjustment is to be made by referring to the above order, 5-1). It is advised to fit each group of parts separately to avoid erroneous fitting.

## 6. Maintenance and inspection.

1) Provide new grease to the grease cup once about a month. Please make it custom to use the special grease that is supplied with the machine.

To provide the new grease, first fill the grease cup with the grease and supply a little grease to its lid. As the lid puts into the cup, the grease gradually permities.

2) Take put the knife time by time to clean off the cut ends inside the knife back and the stand (No.28).

DETAILS AND SPECIFICATIONS SUBJECT TO CHANGE WITHOUT NOTICE.

# Parts List for Model 525N

Parts No.	Parts Name Description	Unit Q'ty	Parts No.	Parts Name Description	Unit Q'ty
1	Motor Front Housing	1 pce.	32	Throat Plate	1 pce.
2	Ball Bearing Lock Nut	1 pce.	33	Set Screw & Washer for the above	2 sets
3	Ball Bearing (6202)	1 pce.	34 *	Roller complete set	2 sets
4	Motor Rear Housing	1 pce.	34-a	Stud (Pin) only	2 pcs.
5	Ball Bearing Lock Nut	1 pce.	34-b	Roller only	4 pcs.
6	Ball bearing (6202)	1 pce.	34-c	Washer only	8 pcs.
7	Set Screw for Pinion Gear	1 pce.	35	Set Screw for the above	2 pcs.
8	Pinion Spiral Bevel Gear (small)	1 pce.	38	Stay Piece for Grinder Lever	1 pce.
9	Spiral Bevel Gear (large)	1 pce.	38-B	Set Screw & Washer for the above	1 set
11-B	Washer for the above	1 pce.	39	Grinder Lever	1 pce.
12	Ball Bearing (B-15-43-CG9)	1 pce.	40	Joint	1 pce.
13	Ball Bearing Lock Nut	1 pce.	41	Lever Spring	1 pce.
14	Knife Retaining Nut	1 pce.	41-B	Set Screw & Washer for the above	1 set
15	Gear Lock Screw	1 pce.	46	Motor Field (Stayer) With Housing (53-1)	1 pce.
16	Grinder Bracket	1 set	47-1	Rotor with Shaft	1 pce.
16-B	Bracket joint	1 pce.	47-2-(5)	Joint Shaft for the above (5" type)	1 pce.
17 *	Stud, Washer, & Screw Emery Stone	2 sets	47-2-(6)	Joint Shaft for the above (6" type)	1 pce.
17-a	Screw	2 pcs.	47-3	Set Screw for the above	2 pcs.
17-b	Washer	2 pcs.	49	Stayer Base (contact Flange)	1 pce.
17-c	Stud	2 pcs.	49-B	Set Screw for the above	2 pcs.
17-d	Pipe Screw	2 pcs.	50	Rotor Base (Governor)	1 pce.
17-e	Washer	2 pcs.	51	Governor Nut	1 pce.
17-f	Screw	2 pcs.	52	Governor Box (cover)	1 pce.
24	Shaft Sack	1 pce.	52-B	Set Screw for the above	2 pcs.
24-B	Set Screw & Washer for the above	2 sets	(53-1)	Motor Field (Stayer) Housing	1 pce.)
25-(5)	Pressure Shaft (5" type)	1 pce.	53-2	Set Screw for the above	2 pcs.
25-(6)	Pressure Shaft (6" type)	1 pce.	54	Operating Handle	1 pce.
25-B	Rubber Washer for the above	1 pce.	55	Switch Box (cover)	1 pce.
25-B-1	Set Screw for the above	1 pce.	55-B	Set screw for the above	2 pcs.
26	Acrylite Plate	2 pcs.	56	Switch for Motor	1 pce.
26-B	Set Screw for the above	4 pcs.	56-B	Cap for the above	1 pce.
27	Adjustable Screw for Pressure Shaft	1 pce.	58	Set Screw for the Terminal Block	2 pcs.
28-(5)	Stand (Foot) (5" type)	1 pce.	60	Set Screw & Washer for Stand to Front Housing	3 pcs.
28-(6)	Stand (Foot) (6" type)	1 pce.	63	Terminal Block	1 pce.
28-B-(5)	Knife Slide (5" type)	1 pce.	57	Carrying Handle	1 pce.
28-B-(6)	Knife Slide (6" type)	1 pce.	57-b	Fixed Screw & Washer for the above	4 pcs.
28-B-1	Set Screw for the above	2 pcs.	65	Knife Blade fastening Key (wrench)	1 pce.
28-C-(5)	Knife Cover (5" type)	1 pce.	67-(5)	Circular Knife Blade 5" diameter	1 pce.
28-C-(6)	Knife Cover (6" type)	1 pce.	67-(6)	Circular Knife Blade 6" diameter	1 pce.
28-C-1	Set Screw for the above	1 pce.	68	Mortar fixed Cap Screw	4 pcs.
28-E	Semicircular Plate	1 pce.	69	Base Plate Wing Pin	1 pce.
29	Grease Cup	1 pce.	70	Base Plate Wing Spring	1 pce.
29-B	Collar for the above	1 pce.	70-B	Set Screw & Washer for the above Spring	1 set
30-(5) *	Base Plate (Bed) complete (5" type)	1 pce.	71	Set Screw for Base Plate Wing Pin	2 pcs.
30-(6) *	Base Plate (Bed) complete (6" type)	1 pce.	72	Electric Cord with Plug	1 pce.
30-a-(5)	Base Plate only (5" type)	1 pce.	72-2	Rubber Tube for Cord	C1 pce.
30-a-(6)	Base Plate only (6" type)	1 pce.	72-3	Terminal Connector Plug	1 pce.
30-b	Plate Wing only	1 pce.	78	Emery Wheel (Sharpening Stone)	2 pcs.
31	Set Screw for Stand to Base Plate	3 pce.			

# Parts List ( 525N )

