

FIGURE 1

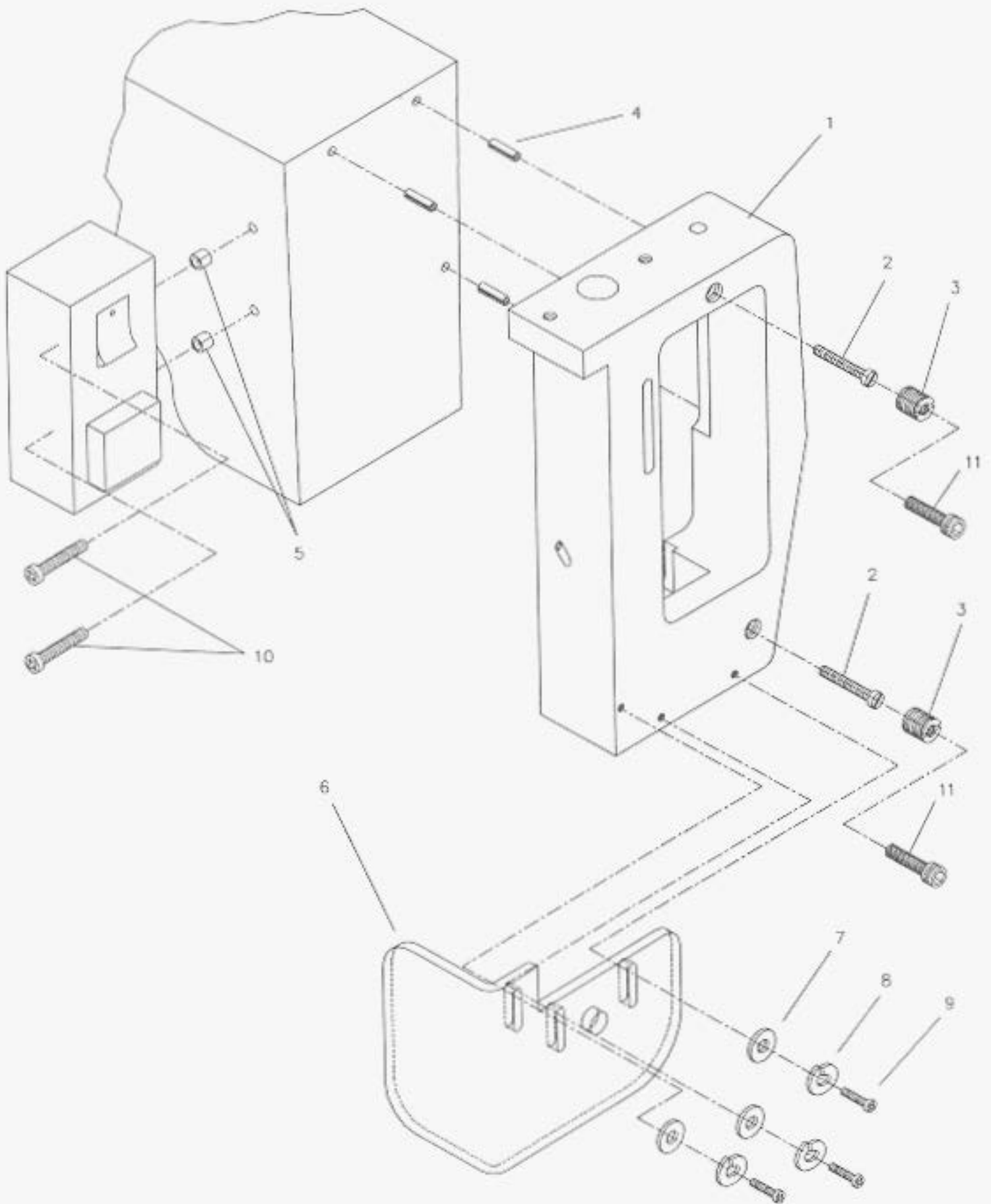

FIGURE 1

VIEW	PART NUMBER	DESCRIPTION	QTY
1	041-2061	MAIN PUNCH HOUSING	1
2	SS7112420SP	HOUSING ATTACHING SCREWS	2
3	041-2072	HOUSING LOCK SCREWS	2
4	041-2074	HOUSING ALIGNMENT SPRING PINS	3
5	041-2500	EMERGENCY SWITCH ASSY. SPACER	2
6	041-2504	EYE GUARD	1
7	041-2501	M3 FLAT WASHER	3
8	041-2502	M3 LOCK WASHER	3
9	041-2503	M3, 14MM SCREW	3
10	SS7111410SP	SCREW	2
11	041-2073	MAIN HOUSING COVER SCREW	2

**FIGURE 2**

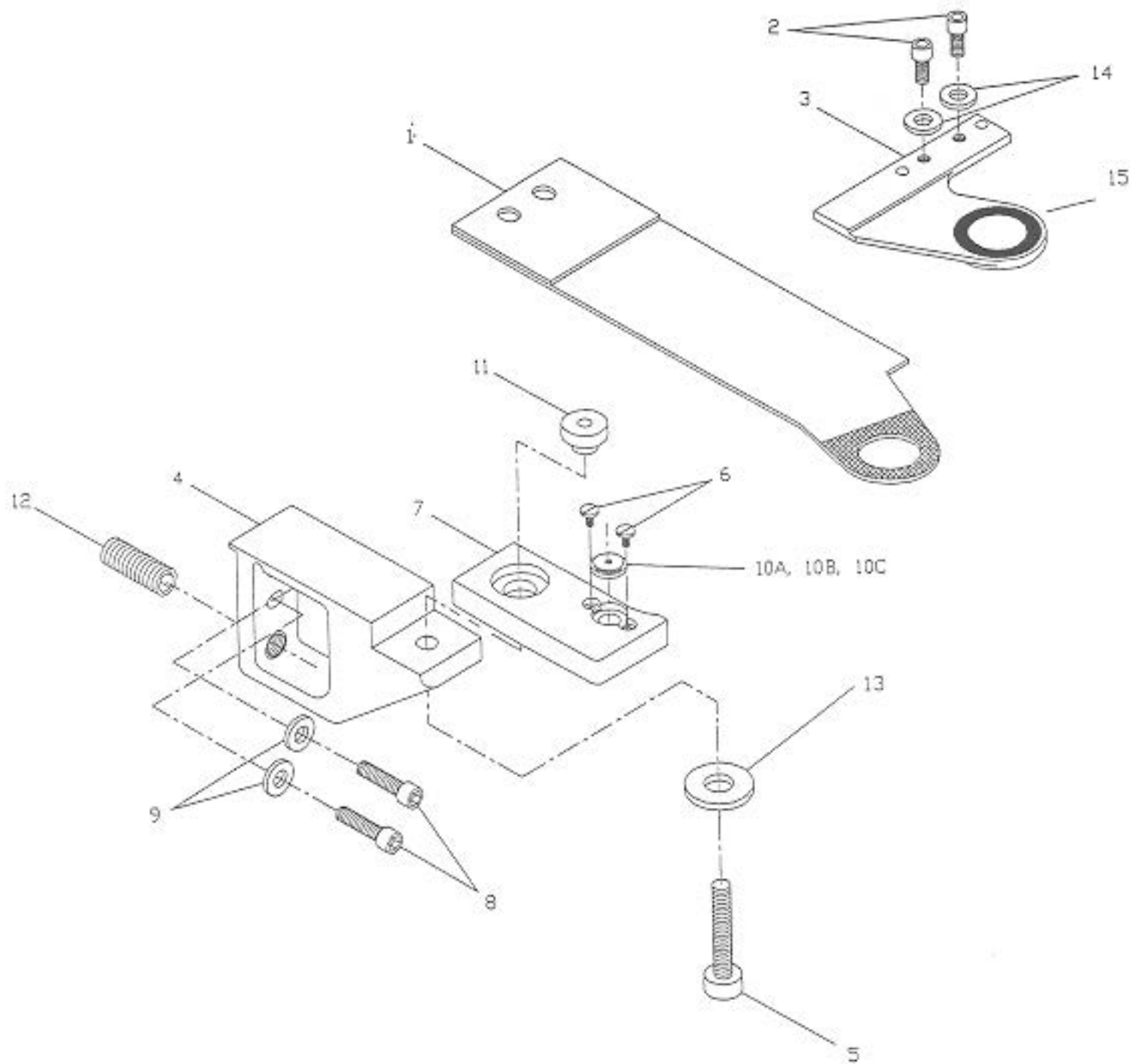

FIGURE 2

VIEW	PART NUMBER	DESCRIPTION	QTY
1	041-2093	FEED PLATE "STANDARD"	1
2	041-2505	10/32 CLAMP SCREWS	2
3	041-2091	TOP CLAMP WITH "O" RING (STANDARD)	1
4	041-2063	PUNCH TABLE SUPPORT BRACKET	1
5	041-2069	PUNCH TABLE ADJUSTING SCREW	1
6	041-2066	PUNCH TABLE INSERT SET SCREWS	2
7	041-2062	PUNCH TABLE ONLY (STEEL)	1
8	041-2067	PUNCH TABLE BRACKET, SCREWS	2
9	041-2068	PUNCH TABLE BRACKET, FLAT WASHERS	2
10A	041-2086-A	1/16 INSERT PLATE	1
10B	041-2086-B	3/32 INSERT PLATE	1
10C	041-2086-C	1/8 INSERT PLATE	1
11	041-2065	PUNCH TABLE POSITION UNIT	1
12	041-2518*	LEVEL ADJUSTING SCREW * (JA-041H ONLY)	1
13	041-2070	PUNCH TABLE SET SCREW, FLAT WASHER	1
14	041-2506	NO. 10 CLAMP FLAT WASHER	2
15	041-2092	RUBBER GROMMET "ONLY"	1

FIGURE 3

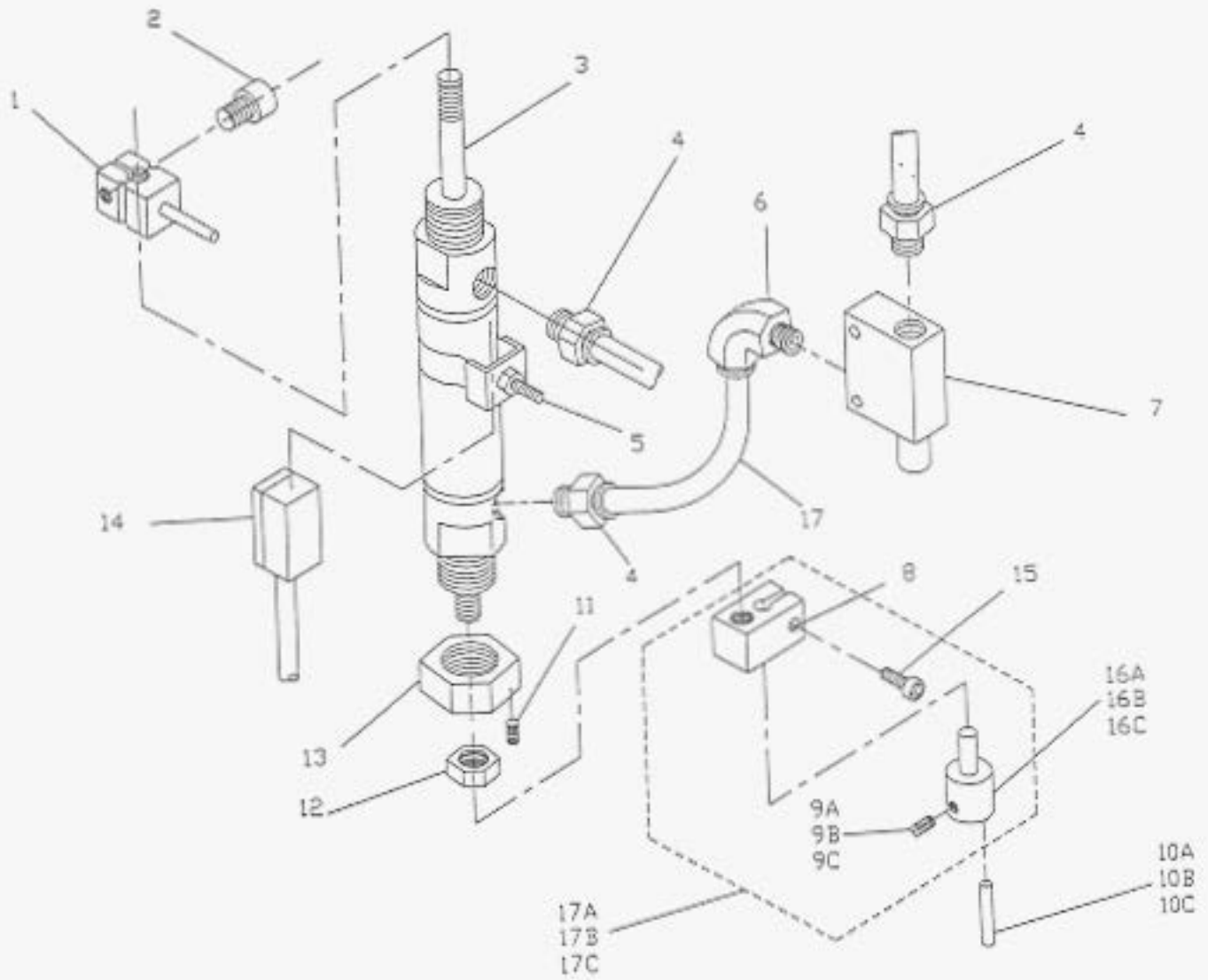
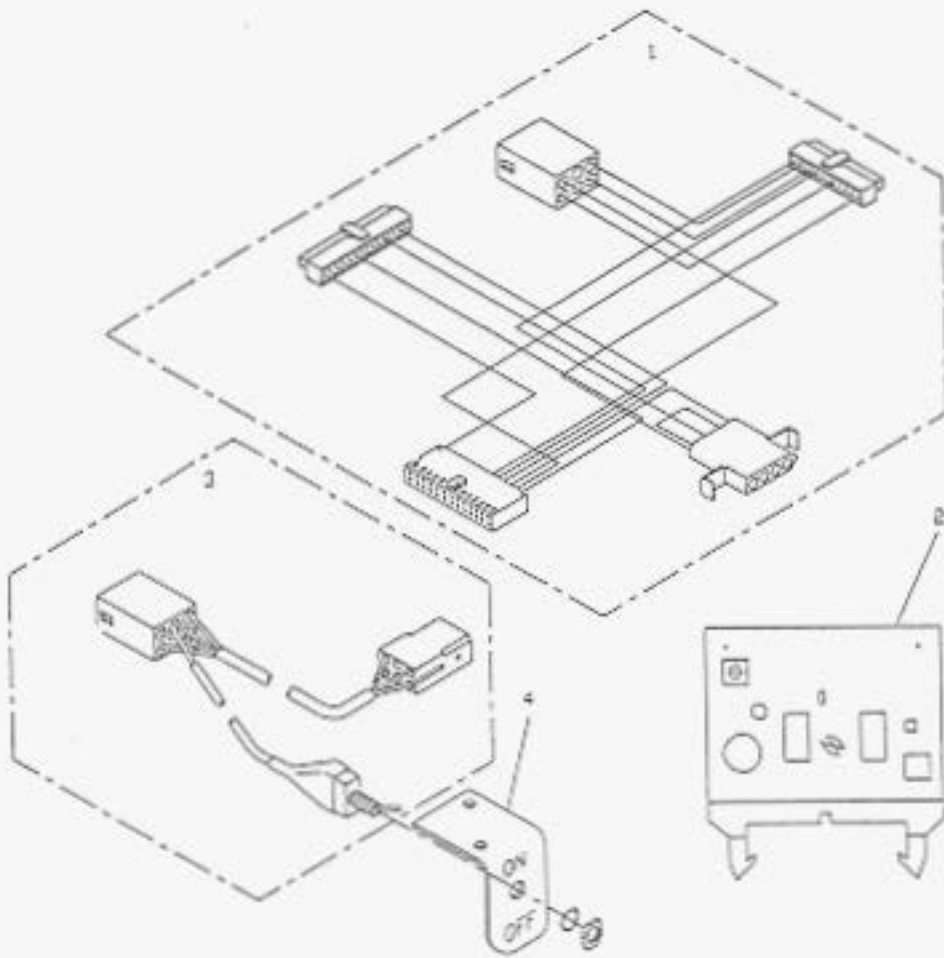

FIGURE 3

VIEW	PART NUMBER	DESCRIPTION	QTY
1	041-2064	CYLINDER GUIDE	1
2	041-2075	CYLINDER GUIDE PINCH SCREW	1
3	041-2507	PUNCH AIR CYLINDER	1
4	041-2512	AIR FITTING 6MM	5
5	041-2510	SENSOR HOLDING CLAMP	1
6	041-2508	ELBOW AIR FITTING 6MM	1
7	041-2509	PUNCH CYLINDER DUMP VALVE	1
8	041-2082	PUNCH PIN BRACKET	1
9A	041-2084A	SET SCREW FOR 041-2083 1/16" (4-40 X 1/4")	1
9B	041-2084B	SET SCREW FOR 041-2083 3/32" (6-32 X 3/16")	1
9C	041-2084C	SET SCREW FOR 041-2083 1/8" (8-32 X 3/16")	1
10A	041-2085A	1/16 PUNCH PIN	1
10B	041-2085B	3/32 PUNCH PIN	1
10C	041-2085C	1/8 PUNCH PIN	1
11	041-2080	PUNCH CYL. LOCK NUT SET SCREW	1
12	041-2081	PUNCH BRACKET JAM NUT	1
13	041-2079	PUNCH CYL. LOCK NUT	1
14	041-2511	SENSOR (M26S)	1
15	041-2103	PINCH SCREW	1
16A	041-2083A	1/16 PUNCH HOLDER	1
16B	041-2083B	3/32 PUNCH HOLDER	1
16C	041-2083C	1/8 PUNCH HOLDER	1
17A	041-2089A	PUNCH PIN BRACKET W/ HOLDER 1/16"	1
17B	041-2089B	PUNCH PIN BRACKET W/ HOLDER 3/32"	1
17C	041-2089C	PUNCH PIN BRACKET W/ HOLDER 1/8"	1





**FIGURE 4**

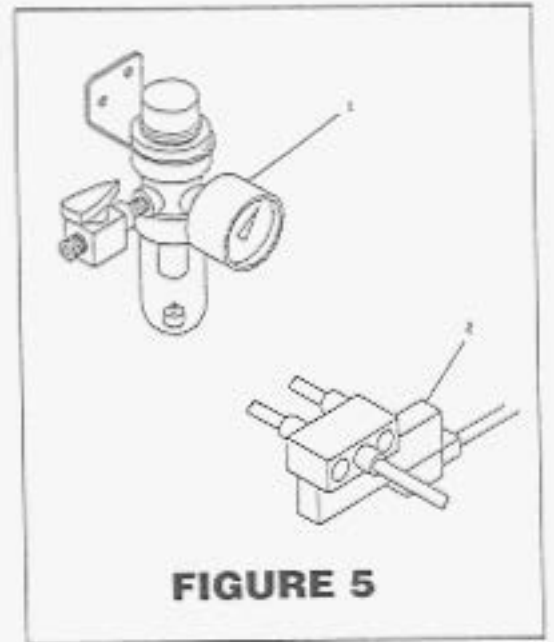

**FIGURE 5**

FIGURE 4 & FIGURE 5

VIEW	PART NUMBER	DESCRIPTION	QTY
1	041-2515	INTERNAL WIRE HARNESS	1
2	041-2516	PUNCH CONTROL CIRCUIT BOARD	1
3	041-2517	EXTERNAL WIRE HARNESS	1
4	041-2519	SWITCH MOUNTING PLATE	1
VIEW	PART NUMBER	DESCRIPTION	QTY
1	041-2514	AIR REGULATOR ASY. (COMPLETE)	1
2	041-2513	PUNCH CONTROL VALVE	1