

BES-111AF *Boutique*

INSTRUCTION MANUAL

BROTHER
EMBROIDERY
SYSTEM

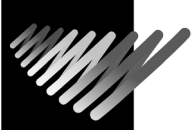

Please read this manual before using the machine.
Please keep this manual within easy reach for quick reference.

COMPACT MONOGRAMMING MACHINE

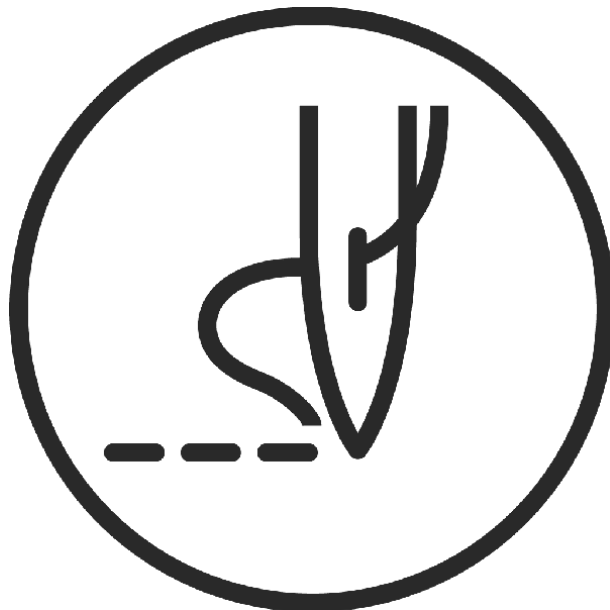

brother[®]

Thank you very much for buying a BROTHER sewing machine. Before using your new machine, please read the safety instructions below and the explanations given in the instruction manual.



With industrial sewing machines, it is normal to carry out work while positioned directly in front of moving parts such as the needle and thread take-up lever, and consequently there is always a danger of injury that can be caused by these parts. Follow the instructions from training personnel and instructions regarding safe and correct operation before operating the machine so that you will know how to use the machine correctly.

SAFETY INSTRUCTIONS

1. Safety indications and their meanings

This instruction manual and the indications and symbols that are used on the machine itself are provided in order to ensure safe operation of this machine and to prevent accidents and injury to yourself or other people. The meanings of these indications and symbols are given below.

Indications

 DANGER	The instructions which follow this term indicate situations where failure to follow the instructions will almost certainly result in death or severe injury.
 CAUTION	The instructions which follow this term indicate situations where failure to follow the instructions could cause injury when using the machine or physical damage to equipment and surroundings.

Symbols



----- This symbol (Δ) indicates something that you should be careful of. The picture inside the triangle indicates the nature of the caution that must be taken.
(For example, the symbol at left means "beware of injury".)



----- This symbol ($\textcircled{/}$) indicates something that you must not do.



----- This symbol (\bullet) indicates something that you must do. The picture inside the circle indicates the nature of the thing that must be done.
(For example, the symbol at left means "you must make the ground connection".)







2. Notes on safety

DANGER







Wait at least 5 minutes after turning off the power switch and disconnecting the power cord from the wall outlet before opening the face plate of the control box. Touching areas where high voltages are present can result in severe injury.

CAUTION

Environmental requirements









<p> Use the sewing machine in an area which is free from sources of strong electrical noise such as high-frequency welders. Sources of strong electrical noise may cause problems with correct operation.</p>	<p> The relative humidity should be within the range of 45% to 85% during use, and no dew formation should occur in any devices. Excessively dry or humid environments and dew formation may cause problems with correct operation.</p>
<p> Any fluctuations in the power supply voltage should be within $\pm 10\%$ of the rated voltage for the machine. Voltage fluctuations which are greater this may cause problems with correct operation.</p>	<p> Avoid exposure to direct sunlight during use. Exposure to direct sunlight may cause problems with correct operation.</p>
<p> The power supply capacity should be greater than the requirements for the sewing machine's electrical consumption. Insufficient power supply capacity may cause problems with correct operation.</p>	<p> In the event of an electrical storm, turn off the power and disconnect the power cord from the wall outlet. Lightning may cause problems with correct operation.</p>
<p> The ambient temperature should be within the range of 5°C to 35°C during use. Temperatures which are lower or higher than this may cause problems with correct operation.</p>	

Installation



<p> Machine installation should only be carried out by a qualified technician.</p>	<p> Be sure to wear protective goggles and gloves when handling the lubricating oil and grease, so that they do not get into your eyes or onto your skin, otherwise inflammation can result.</p>
<p> Contact your Brother dealer or a qualified electrician for any electrical work that may need to be done.</p>	<p>Furthermore, do not drink the oil or eat the grease under any circumstances, as they can cause vomiting and diarrhea. Keep the oil out of the reach of children.</p>
<p> The sewing machine weighs more than about 30 kg. The installation should be carried out by two or more people.</p>	<p> Avoid setting up the sewing machine near sources of strong electrical noise such as high-frequency welding equipment. If this precaution is not taken, incorrect machine operation may result.</p>
<p> Do not connect the power cord until installation is complete, otherwise the machine may operate if the foot switch is depressed by mistake, which could result in injury.</p>	
<p> Be sure to connect the ground. If the ground connection is not secure, you run the risk of receiving a serious electric shock.</p>	

⚠ CAUTION







Sewing

	This sewing machine should only be used by operators who have received the necessary training in safe use beforehand.		Turn off the power switch at the following times, otherwise the machine may operate if the foot switch is depressed by mistake, which could result in injury.
	The sewing machine should not be used for any applications other than sewing.		<ul style="list-style-type: none"> - When threading the needle - When replacing the bobbin and needle - When not using the machine and when leaving the machine unattended
	Be sure to wear protective goggles when using the machine. If goggles are not worn, there is the danger that if a needle breaks, parts of the broken needle may enter your eyes and injury may result.		If an error occurs in machine operation, or if abnormal noises or smells are noticed, immediately turn off the power switch. Then contact your nearest Brother dealer or a qualified technician.
	Attach all safety devices before using the sewing machine. If the machine is used without these devices attached, injury may result.		If the machine develops a problem, contact your nearest Brother dealer or a qualified technician.
	Do not touch any of the moving parts or press any objects against the machine while sewing, as this may result in personal injury or damage to the machine.		

Cleaning

	Turn off the power switch before starting any cleaning work, otherwise the machine may operate if the foot switch is depressed by mistake, which could result in injury.		Be sure to wear protective goggles and gloves when handling the lubricating oil and grease, so that they do not get into your eyes or onto your skin, otherwise inflammation can result. Furthermore, do not drink the oil or eat the grease under any circumstances, as they can cause vomiting and diarrhea. Keep the oil out of the reach of children.
---	--	---	---

Maintenance and inspection

	Maintenance and inspection of the sewing machine should only be carried out by a qualified technician.		If the power switch needs to be left on when carrying out some adjustment, be extremely careful to observe safety precautions.
	Ask your Brother dealer or a qualified electrician to carry out any maintenance and inspection of the electrical system.		Use only the proper replacement parts as specified by Brother.
	Turn off the power switch and disconnect the power cord from the wall outlet at the following times, otherwise the machine may operate if the foot switch is depressed by mistake, which could result in injury.		If any safety devices have been removed, be absolutely sure to re-install them to their original positions and check that they operate correctly before using the machine.
	<ul style="list-style-type: none"> - When carrying out inspection, adjustment and maintenance - When replacing consumable parts such as the rotary hook and knife 		Any problems in machine operation which result from unauthorized modifications to the machine will not be covered by the warranty.

3. Warning labels

The following warning labels appear on the sewing machine. Please follow the instructions on the labels at all times when using the machine. If the labels have been removed or are difficult to read, please contact your nearest Brother dealer.



Safety devices: Thread take-up cover, Belt cover, etc.

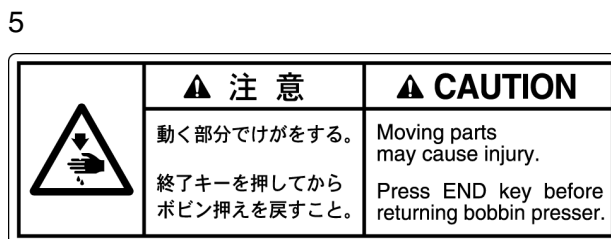

4 Direction of operation

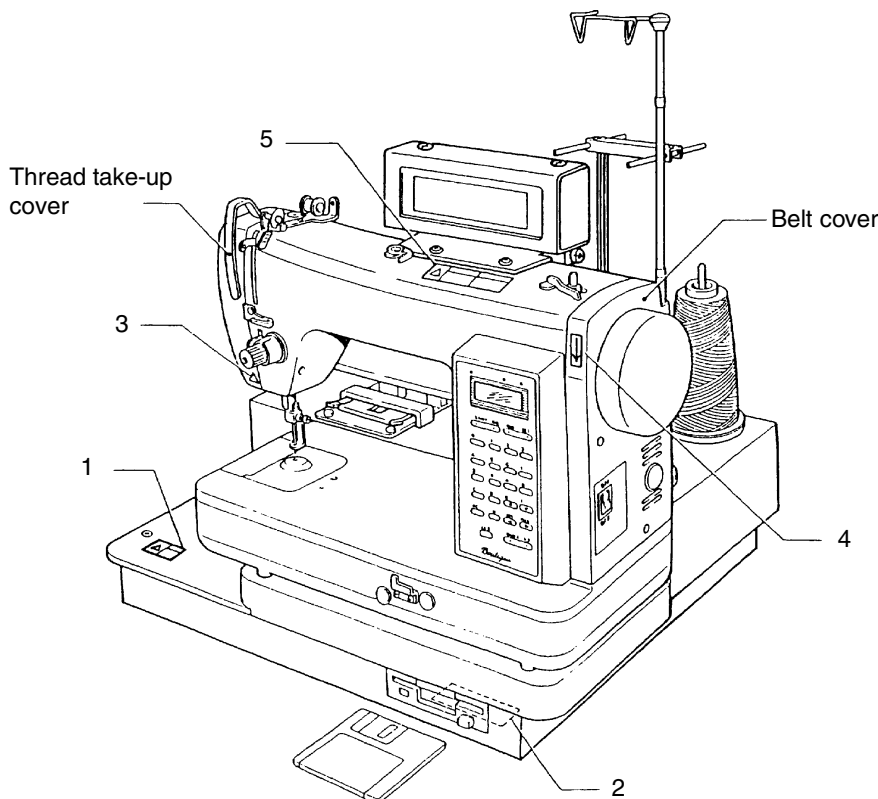
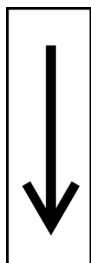

H0527

CONTENTS

1. An Introduction of Sewing Machine.....	1
1-1. Specifications.....	1
2. Preparation of Sewing Machine	2
2-1. Part names	2
2-2. Threading the needle thread.....	4
2-3. Winding the bobbin thread.....	5
2-4. Correctly wound bobbin.....	6
2-5. Replacing the bobbin.....	6
2-6. Replacing the needle.....	7
2-7. Installing the embroidery hoop	7
2-8. Adjusting the presser foot height.....	8
2-9. Drawing out the bobbin thread	8
2-10. Thread tension	9
2-11. Replacing the lamp.....	10
2-12. Cleaning	11
2-13. Lubrication	12
3. Sewing Preparation	13
3-1. Flow chart	13
3-2. Operation panel part names and functions	14
3-3. DIP switch function.....	17
3-4. Floppy disk	18
3-5. Connecting a keyboard and entering characters.....	20
4. Sewing Procedure	22
4-1. Alphanumerics (upper and lower case letters, numbers).....	22
4-1-1. If "Area over" is displayed	23
4-1-2. If "Short of area" is displayed	24
4-1-3. Correcting a letter	25
4-2. Setting the letter spacing	26
4-2-1. Space and sewing position	30
4-3. Pause	31
4-4. Carriage return.....	31
4-5. Selecting fonts for letters and numbers	32
4-5-1. To embroider the letters	33
4-5-2. Letter monogram specifications (optional)	34
4-6. How to install Tajima floppy disk.....	36
4-7. Storing character data on disk (creating a storage disk).....	37
4-8. Reading character data	39
5. Sewing Function	42
5-1. Sewing.....	42
5-2. Test sewing	44
5-3. To change the sewing start position after test sewing.....	45
5-4. Cancel	45
5-4-1. Changing and editing monogram letters	46
5-4-2. Resewing	46
5-4-3. Replacing the floppy disk.....	47
5-4-4. Environment settings	48

6. Editing	49
6-1. Editing letters and numbers.....	49
6-2. Edit item selection	50
6-3. Setting the sewing area	51
6-3-1. Setting sewing area for hoop number 02.....	51
6-3-2. Setting sewing area for hoop number	52
6-3-3. Setting the monogram area	53
6-4. Enlarging or reducing.....	55
6-4-1. Setting the size ratio altogether	55
6-4-2. Setting the size ratio individual (1)	57
6-4-2. Setting the size ratio individual (2)	59
6-4-3. Automatic calculation	61
6-4-4. Designate dimensions.....	62
6-5. Thread density and letter width	64
6-5-1. Thread density.....	64
6-5-2. Letter width.....	65
6-6. Arrange	66
6-7. Rotation	67
6-7-1. If lateral alignment is selected	67
6-7-2. If Vertical alignment is selected.....	68
6-8. Centering	69
6-8-1. With centering.....	70
6-8-2. Without centering.....	71
6-8-3. Setting the needle start position and sewing position.....	72
6-9. Editing item confirmation.....	73
6-10. Setting the sewing speed	75
6-11. Stop position change function	76
7. Optional Parts	77
7-1. Sub table.....	77
7-2. Spring	77
8. Trouble Shooting	78
9. Error Messages	80
10. X-Y Feed Adjustment	81
10-1. Removing the X-Y feed unit	81
10-2. Adjusting the wire in the X direction.....	82
10-3. Adjusting the wire in the Y direction.....	82
11. Adjusting the upper thread breakage detector.....	83
11-1. Checking the upper thread breakage detector operation	83
11-2. Cleaning the upper thread breakage detector	83
12. Character Code List	84
13. Floppy Disk Input Contents List	85

1. An Introduction of Sewing Machine

- Interactive operation makes monogramming names easier than ever for beginners.
- Designed to be compact. Minimal installation space is required.
- Company names, club or team names, and other letters sewn can be stored on floppy disk for later use.
- Twenty-eight styles of lettering are available.
- Letter size, thread density and letter width, letter alignment, and sewing area can be easily set, and letters can be individually added or deleted for easier editing of the monogram.
- Optional disks of pattern designs (for sports, animals, flowers, Zodiac signs, design frames) are also available.

1-1. Specifications

Sewing machine model	BES-111AF
Application	Monogramming on suits, shirts, sportswear, handkerchiefs, other articles
Maximum sewing speed	1000 rpm
Sewing area	120 mm × 100 mm
Stitch length	0.1 - 12.7 mm
Storage medium	3.5 floppy disk
Power source/consumption	Single phase, 120, 220, 240V 50/60Hz 200VA
Dimensions	400 mm (D) × 540 mm (W) × 470 mm (H)
Weight	30 kg

2. Preparation of Sewing Machine

2-1. Part names

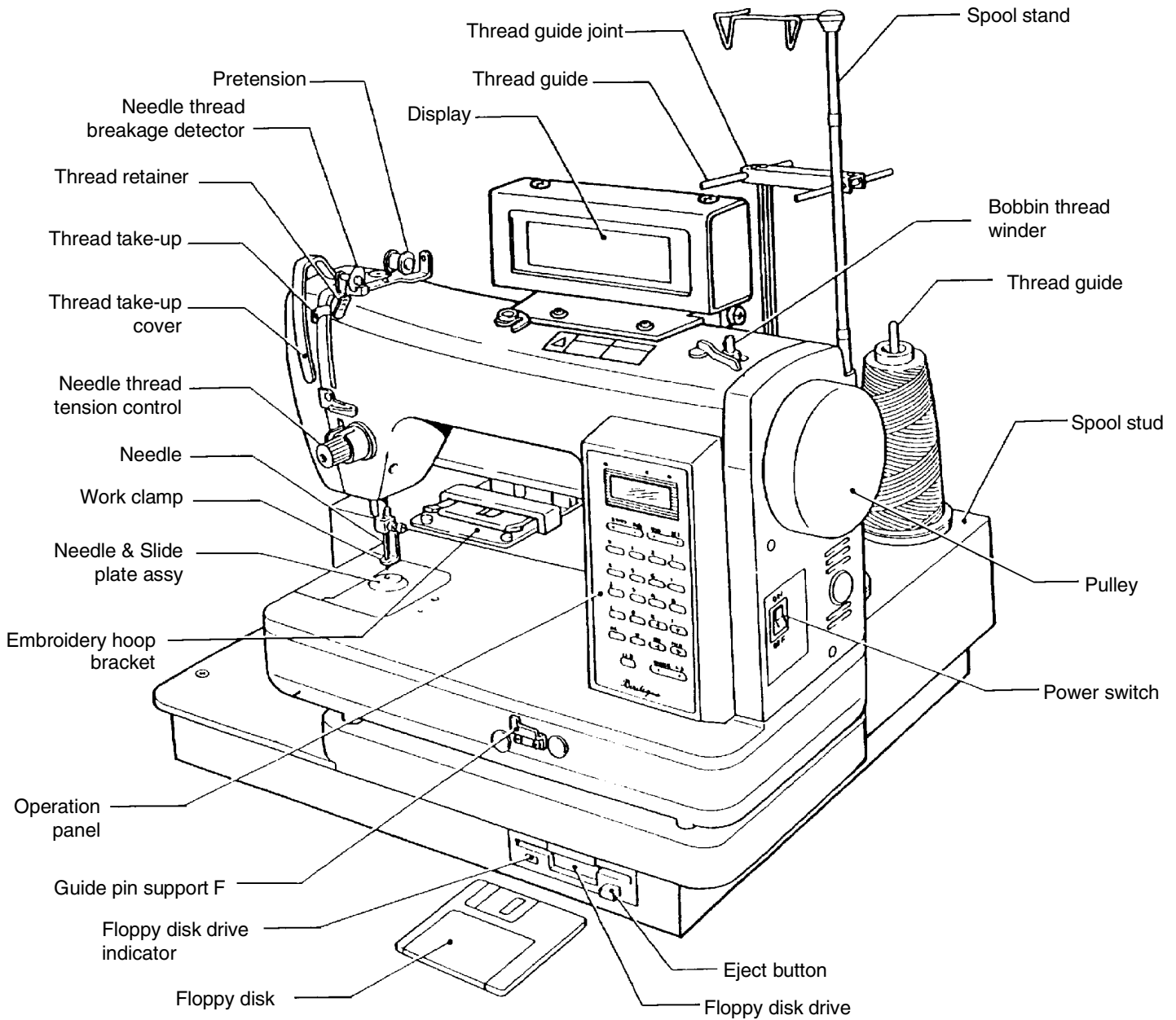

H0528

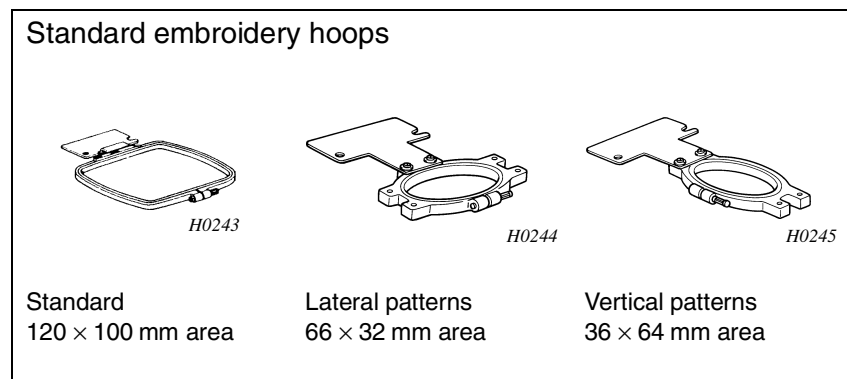
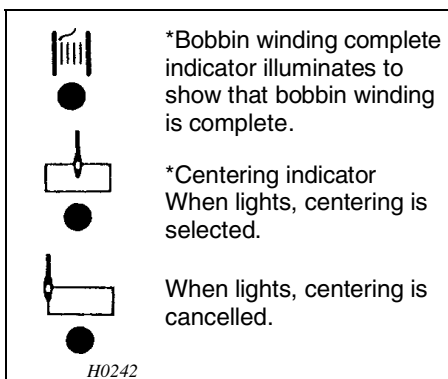

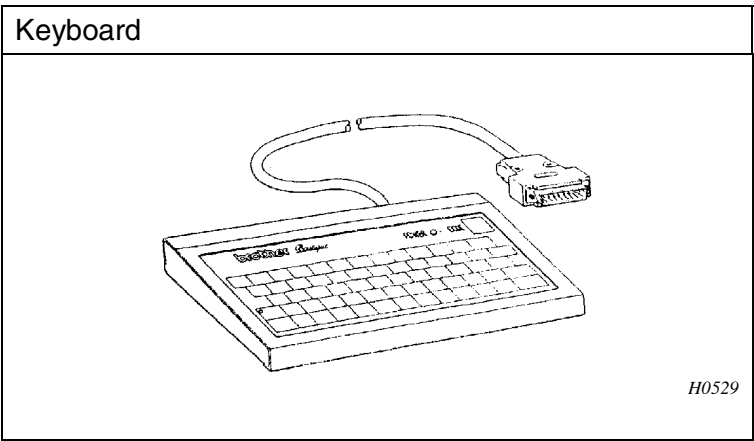
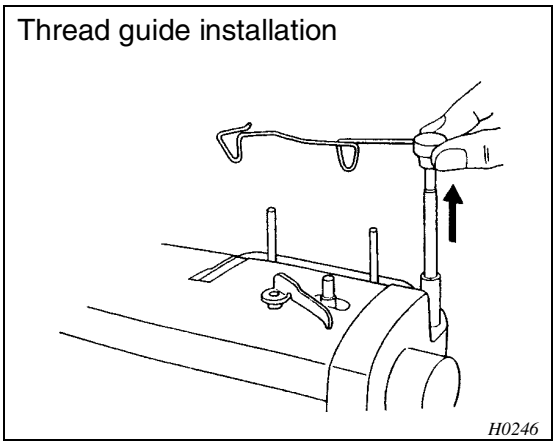

Optional accessories (sold separately)

Embroidery hoops
Using the most suitable hoop size for the job at hand provides better results.

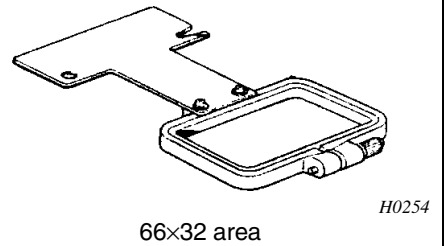
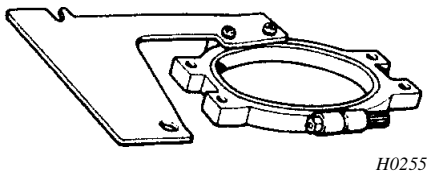
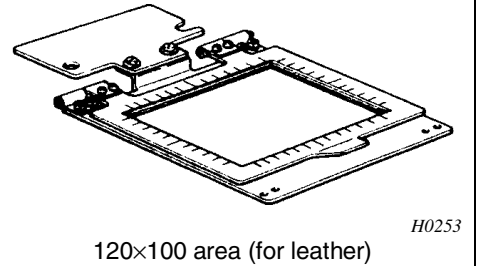
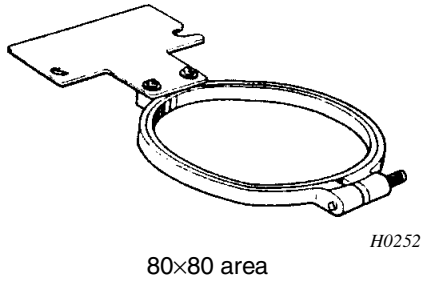
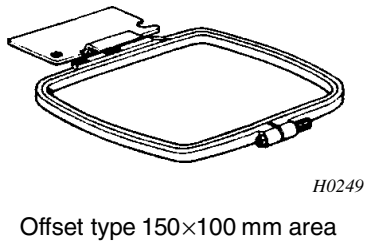
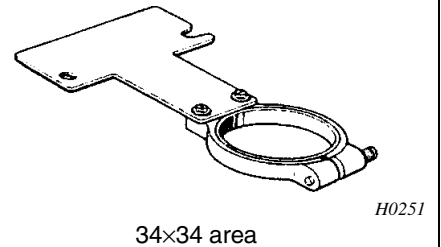
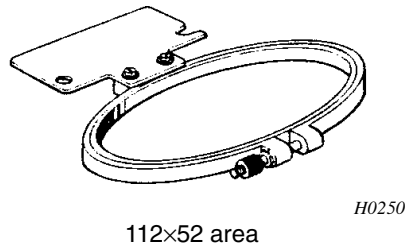
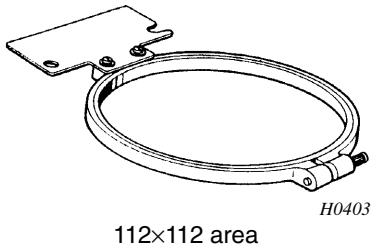

Portable table

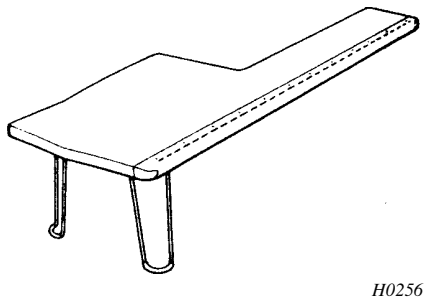

Spring



2-2. Threading the needle thread

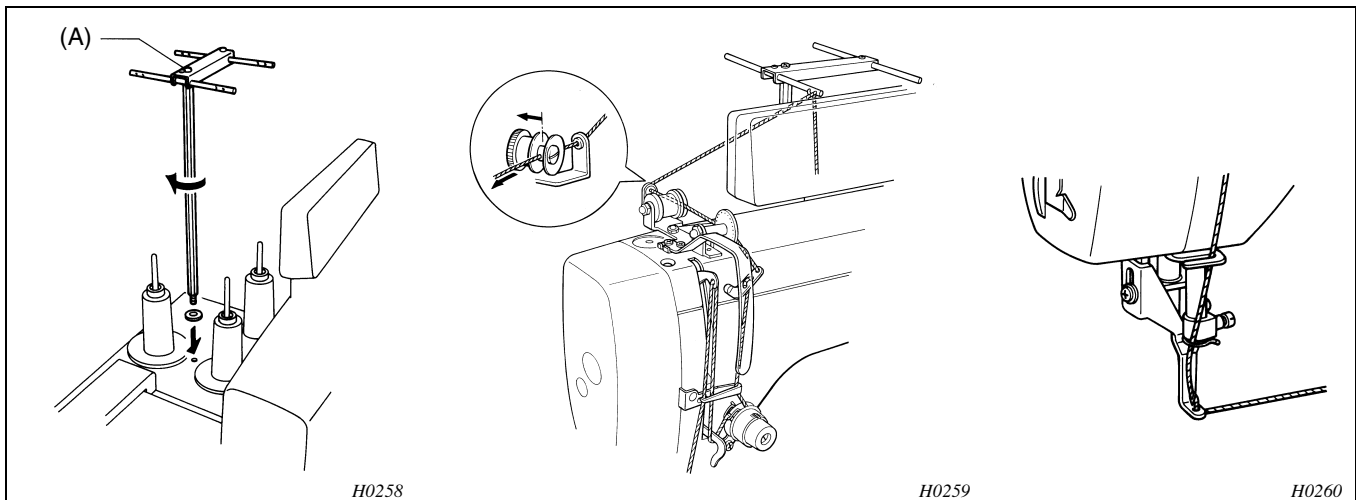

1. Thread the thread guide.

2. Thread the pretension.

3. Thread the thread guide for the needle thread breakage detector.

4. Thread the thread retainer.

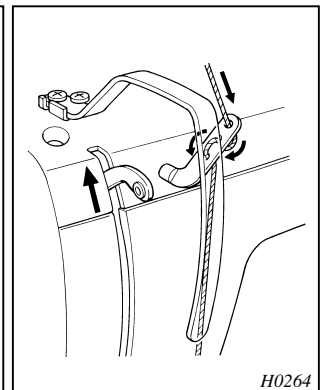
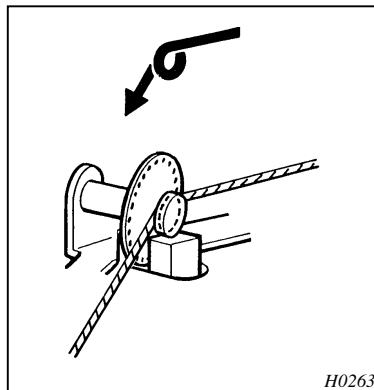
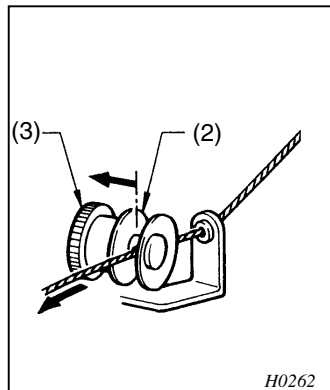
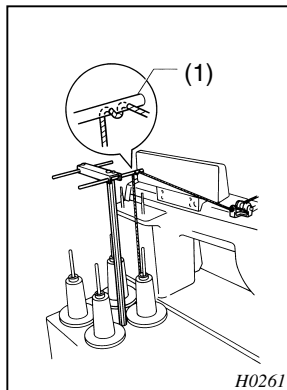

Pass the thread from the outside to the inside of the thread guide (1).

Press the thread guide disc (2) to open it, pass the thread through the hole, and adjust the thread tension by means of the pulley (3).

Wind the thread 2 - 3 times so that it crosses over at the bottom as shown in the illustration.

Turn the pulley to raise the thread take-up lever to its upper position. Thread in order shown above.

Installing and adjusting the thread guide

(Approx. 60 g)
0.05 - 0.1 N

- Screw the thread guide support bar in as far as it will go.

5. Thread the thread tension bracket.

6. Thread the thread take-up.

7. Thread the thread guide and needle.

- If the thread guide is misaligned, loosen the screw (A) and turn the thread guide until the thread guide hole comes to directly above the needle bar.

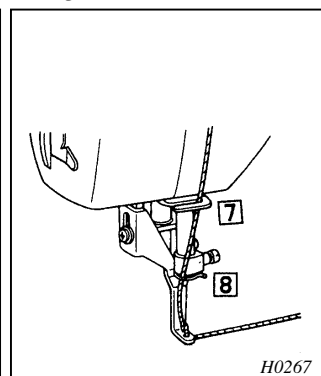
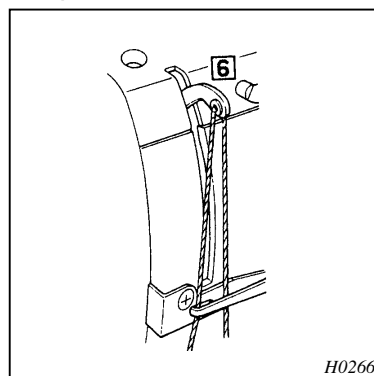
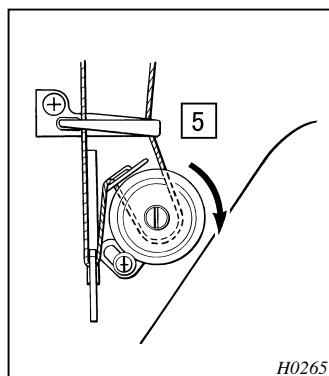

2-3. Winding the bobbin thread

1. Set the bobbin thread

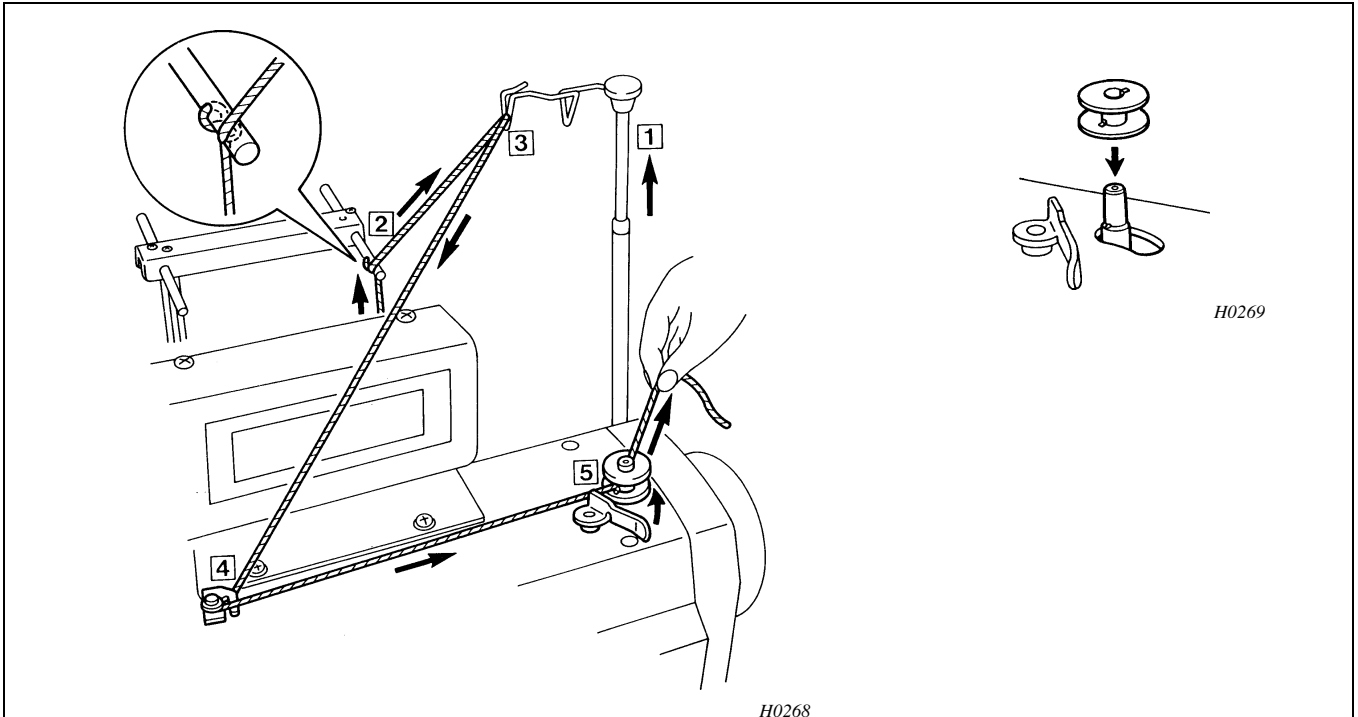

2. Turn the power switch on

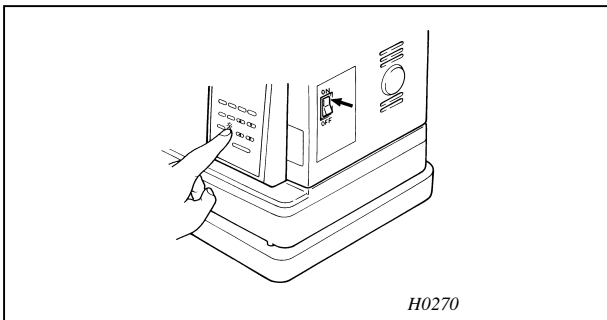

Press the confirm/test <※> key, and turn the power switch on. [Pull out upper thr. from needle], and [Attention moving] will be alternately displayed.

"BOBBIN THREAD WINDING START > START END > END" will be displayed.

3. Fill the bobbin

Pass the thread through the hole in the bobbin. Hold the end of the thread and press <START>.

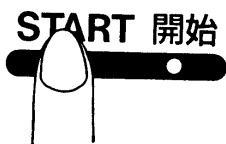

4. Bobbin is full

The bobbin will stop rotating when it becomes full. Press <END>, check that the sewing machine has stopped running, and then return the bobbin presser to its original position.

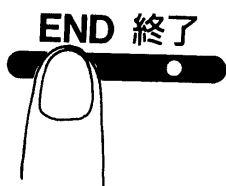

(NOTE) - If the bobbin stops rotating before it becomes completely full, press <END> to stop the sewing machine.

- If the bobbin presser is returned too quickly while the sewing machine is running, the movement will be transmitted to the needle bar, which might cause the needle to move.

2-4. Correctly wound bobbin

If the bobbin thread is not wound on the bobbin evenly, it may cause an incorrect bobbin thread tension.

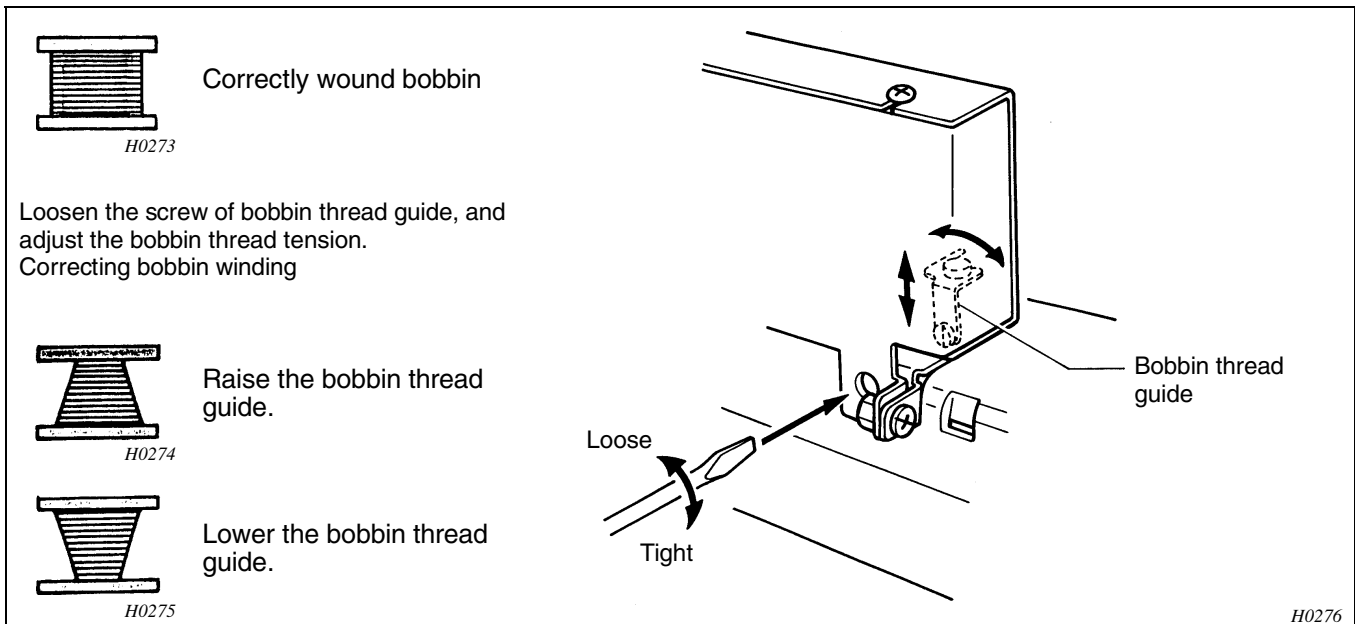

The bobbin will stop rotating when it becomes full. Press <END>, check that the sewing machine has stopped running, and then return the bobbin presser to its original position.

(MEMO) If the bobbin stops rotating before it becomes completely full, press <END> to stop the sewing machine.

If the bobbin presser is returned too quickly while the sewing machine is running, the movement will be transmitted to the needle bar, which might cause the needle to move.

2-5. Replacing the bobbin

(NOTE) The bobbin spring may not function properly, resulting in bobbin thread breakage, if thread ends and dust collect inside the bobbin case. Be sure to keep the bobbin case and the shuttle body clean at all times.

1. Remove the bobbin case.

2. Replace the bobbin.

3. Replace the bobbin case.

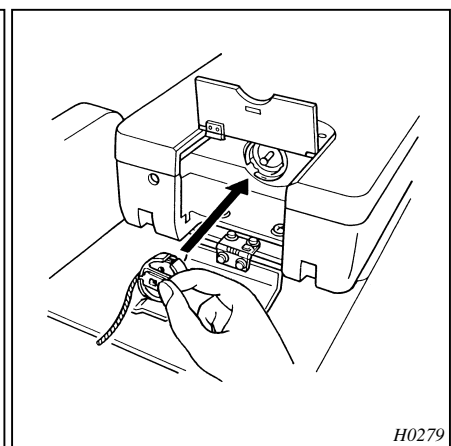
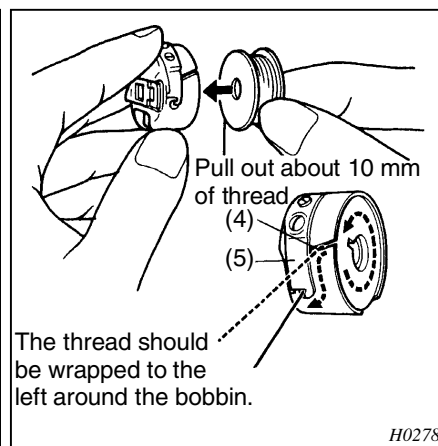
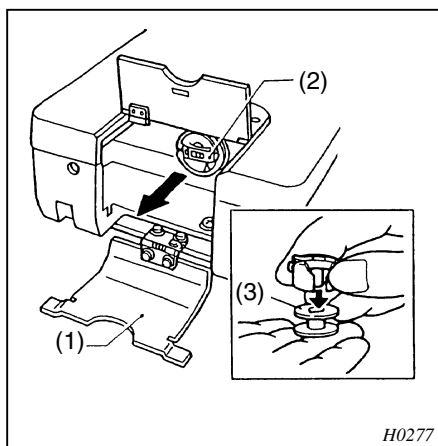

1. Open the needle plate side cover (1).
2. Pull out latch (2) and remove the bobbin case.
3. Return the latch (2) to the original position and remove the bobbin (3).

1. Close the bobbin case handle.
2. Pass the thread through the notch [4] and under the tension spring [5].

1. Hold the latch (2) and insert the bobbin case into the rotary hook assembly.
2. Close the cover (1).

2-6. Replacing the needle

CAUTION



Turn off the power switch before starting any cleaning work, otherwise the machine may operate if the start switch is pressed by mistake, which could result in injury.

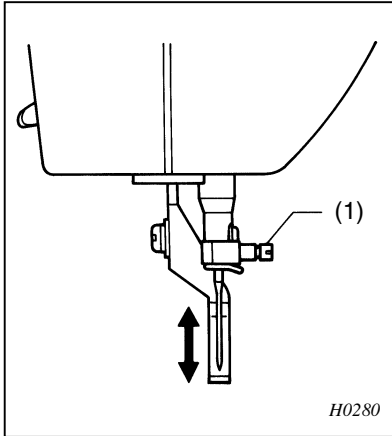

* Checking needle is correct
Hold the needle with the flat side down.

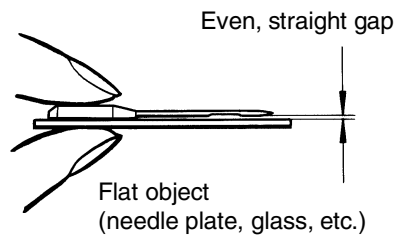

1. Loosen the screw (1), and remove the needle.
2. Hold the needle so that the flat side is to the right, insert until it stops, and then tighten the needle clamp screw (1).

* Hold the flat side of the needle against a flat object to make sure that the gap is even along the length of the needle and the needle is straight.

(NOTE) Using an incorrect needle may cause stitches to be skipped, thread breakage, or damage to the material. Check the needle condition occasionally.

Materials and needle selection

Fabric type	Needle size	Embroidery thread
Denim, leather	HL × 5 #11 - #16	#75 - #150 denier
Handkerchief, shirt, towel	HL × 5 #9 - #11	

(NOTE) Better results can be obtained by using a heavy-duty needle (#11 - #14) when sewing with special threads (gold, silver, or other ramie yarns).

2-7. Installing the embroidery hoop

1. Fit the material into the embroidery hoop.

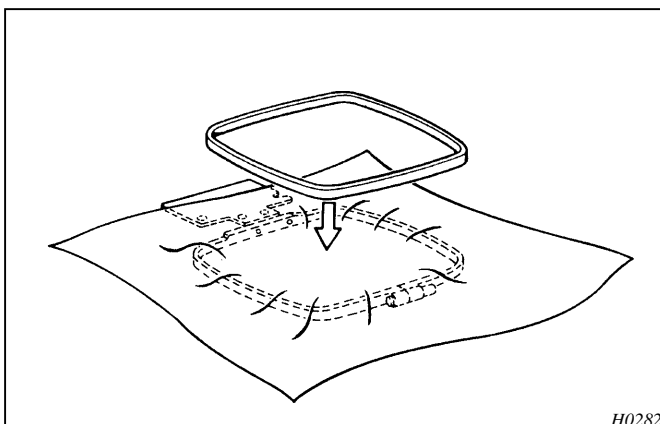

A poor fitting embroidery hoop may cause skipped stitches, thread breakage, puckering, or other problems.

2. Install the embroidery hoop.

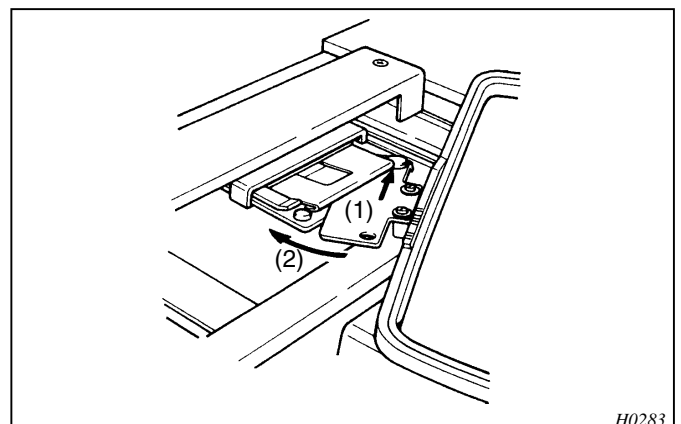

Install the embroidery hoop firmly as shown above.

2-8. Adjusting the presser foot height

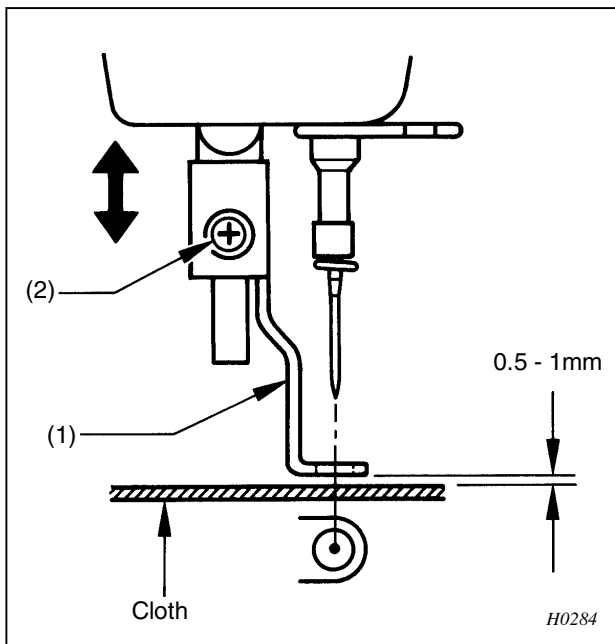

Turn the pulley to lower the presser foot (1) to its lowest position. Loosen the screw (2). Adjust the presser foot (1) by moving it up or down so that there is a 0.5 - 1 mm clearance between the top of the material and the bottom of the presser foot (1).

2-9. Drawing out the bobbin thread

1. Turn the pulley.

2. Pull the needle thread up.

3. Pull out the bobbin thread.

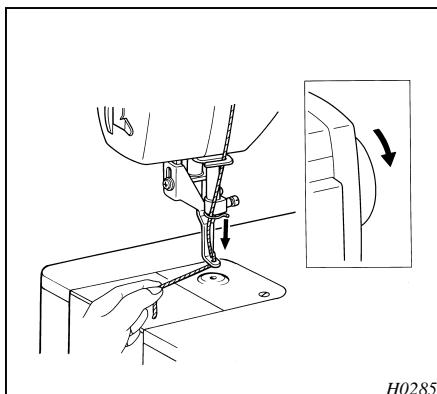

Hold the needle thread gently and turn the pulley.

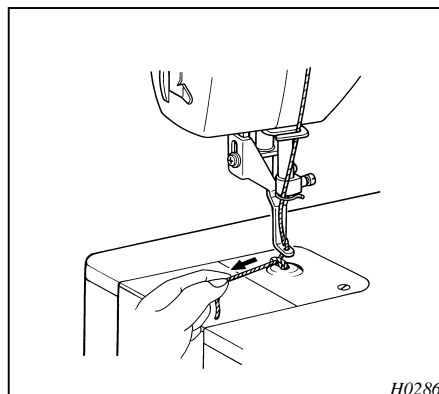

Pull the needle thread to draw the bobbin thread out.

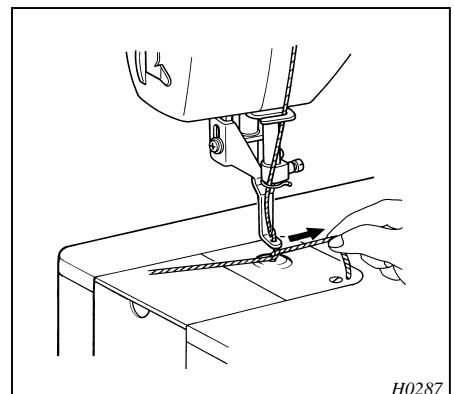

Pull both the needle and bobbin threads out about 40 mm.

(NOTE) To pull the bobbin thread out on top of the material, press <START> when sewing, and press any key before the embroidery hoop starts moving. The machine will stop. Pull the bobbin thread out as described above. The machine will start sewing when <START> is pressed. Press any key after sewing about 5 stitches. After the machine stops, cut the bobbin thread ends. Press <START> to continue sewing.

2-10. Thread tension

If the thread tension is not adjusted properly, irregular stitching, material puckering, or thread breakage may occur.

Needle thread tension

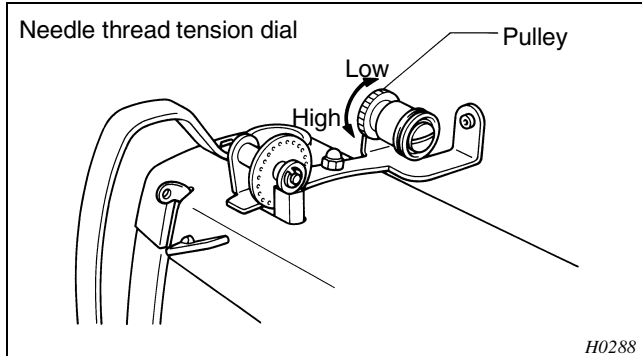

If the upper thread tension is too strong, turn the pulley counterclockwise.
If the upper thread tension is too weak, turn the pulley clockwise.
0.05 - 0.1 N

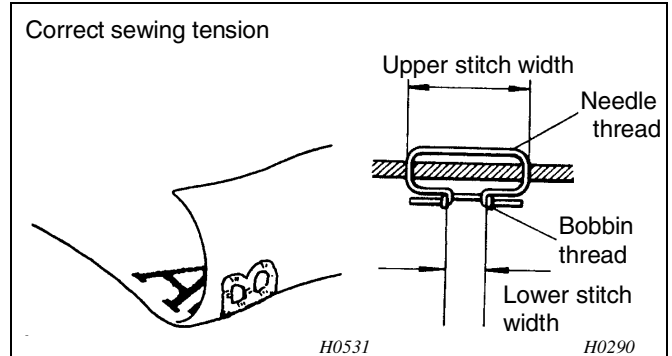

Adjust the tension dial so that the needle thread is pulled to the back of the material, and the bottom stitch width is about 1/3 that of the upper stitch width.

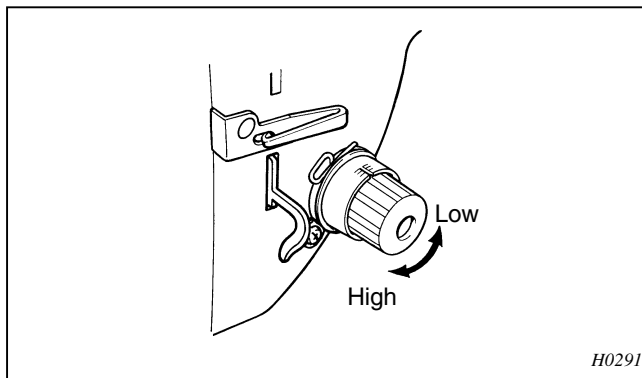

Use the thread tension dial to make fine adjustments.

- If the needle thread tension is too high, turn the clockwise.
- If the needle thread tension is too low, turn the counterclockwise.

Bobbin thread tension

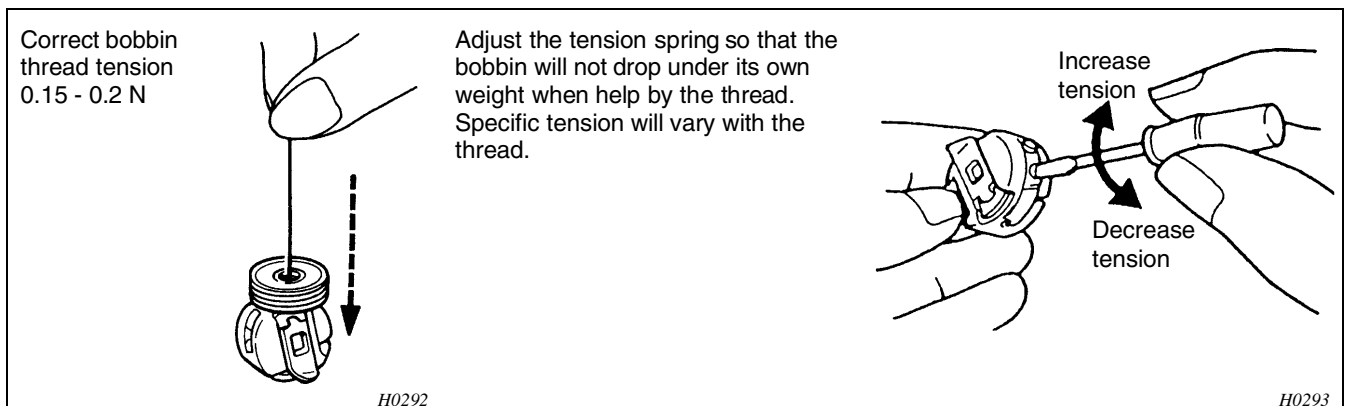

2-11. Replacing the lamp

CAUTION



Turn off the power before replacing the lamp. The glass part of the lamp will be not immediately after the lamp has blown, so let it stand for a while until it becomes cool before attempting to replace it.

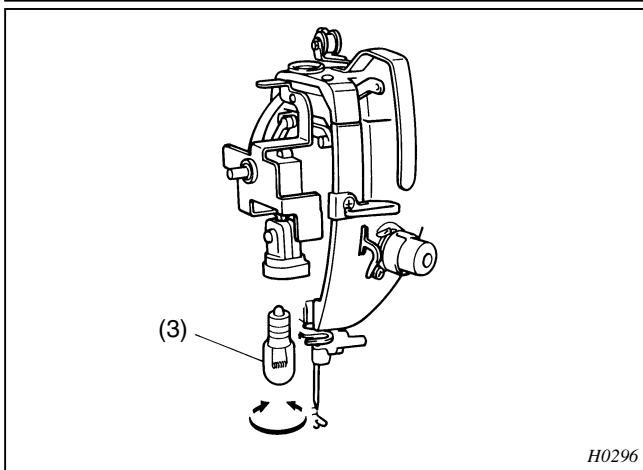
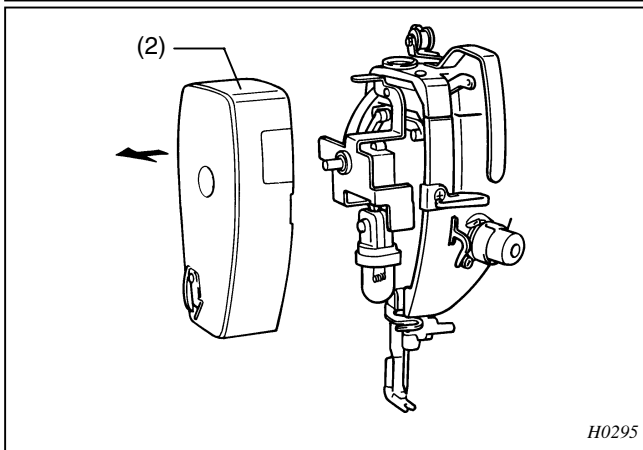
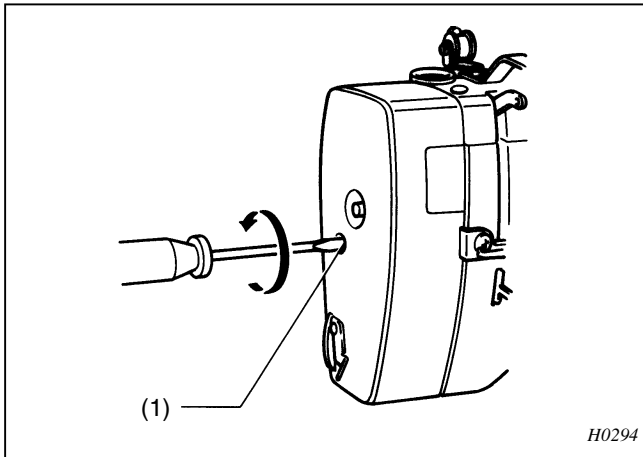

1. Turn off the power switch.
2. Remove the screw (1).

3. Remove the face plate (2).

4. Unscrew and remove the lamp (3).
5. Install the new lamp.
6. Install the face plate (2) with the screw (1).

2-12. Cleaning

A dirty or clogged machine may result in equipment failure. Be sure to keep the machine clean at all times.

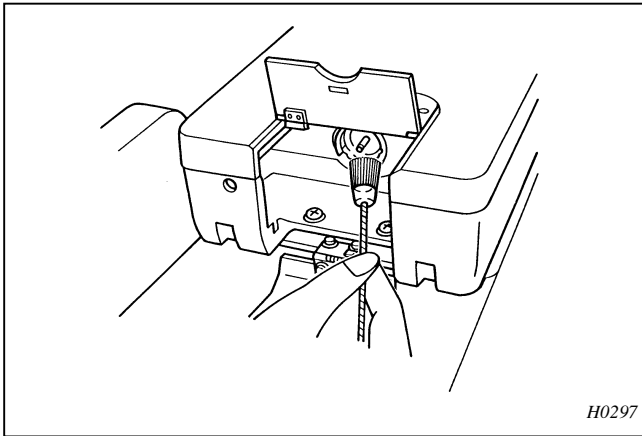

Always clean

If the machine is only slightly dirty or dusty, wipe clean with a soft, dry cloth. If necessary, wipe with a cloth dampened with a neutral detergent or hot water, and then wipe the detergent off cleanly with a cloth dampened with hot or cold water.

Do not clean with benzene, thinner, or other volatile solvents.

(MEMO) When cleaning the rotary hook and its associated parts, add 1 - 2 drops of oil to the rotary hook mechanism. After lubrication, try sewing.

Refer to page 12 "Lubrication."

Avoid high temperatures

Keep the machine away from hot stoves, irons, and similar heat sources. Store the machine out of direct sunlight.

2-13. Lubrication

CAUTION



Turn off the power switch before starting any cleaning work, otherwise the machine may operate if the start switch is pressed by mistake, which could result in injury.

- (NOTE) - Be sure to use Brother-specified sewing machine oil for lubrication.
- Adding too much lubrication oil may cause the oil to get on the material; be careful not to overfill the reservoir.

(NOTE) - Add 2-3 drops of oil at each position indicated by an arrow.
If there is oil around the lubrication position, wipe it off with a cloth.

- Lubrication is necessary at least once a month.
(If the machine is used for several hours every day, lubricate daily.)
- Lubricate the machine after using it and then be sure to run the machine without thread or material.

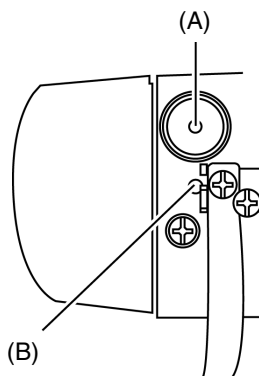

H0298

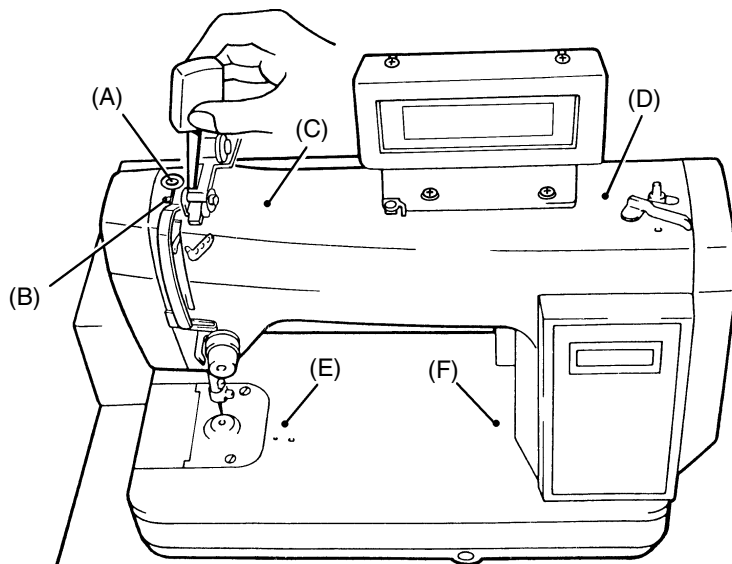

H0299

1. Open the needle plate side cover (1).
 2. Remove the bobbin case (2).
 3. Add a drop of oil to the rotary hook.
- (NOTE) DO NOT lubricate anywhere else.

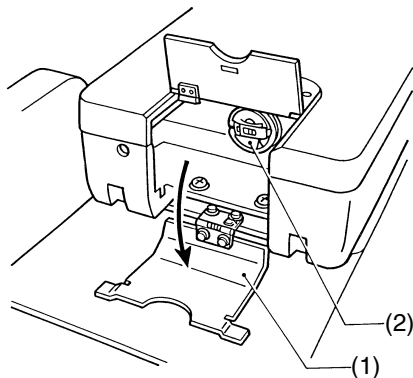

H0300

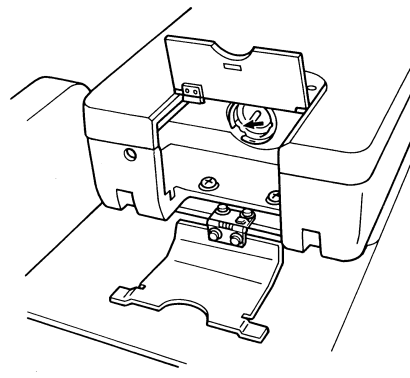

H0301

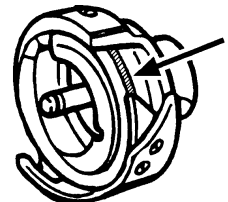

H0302

3. Sewing Preparation

3-1. Flow chart

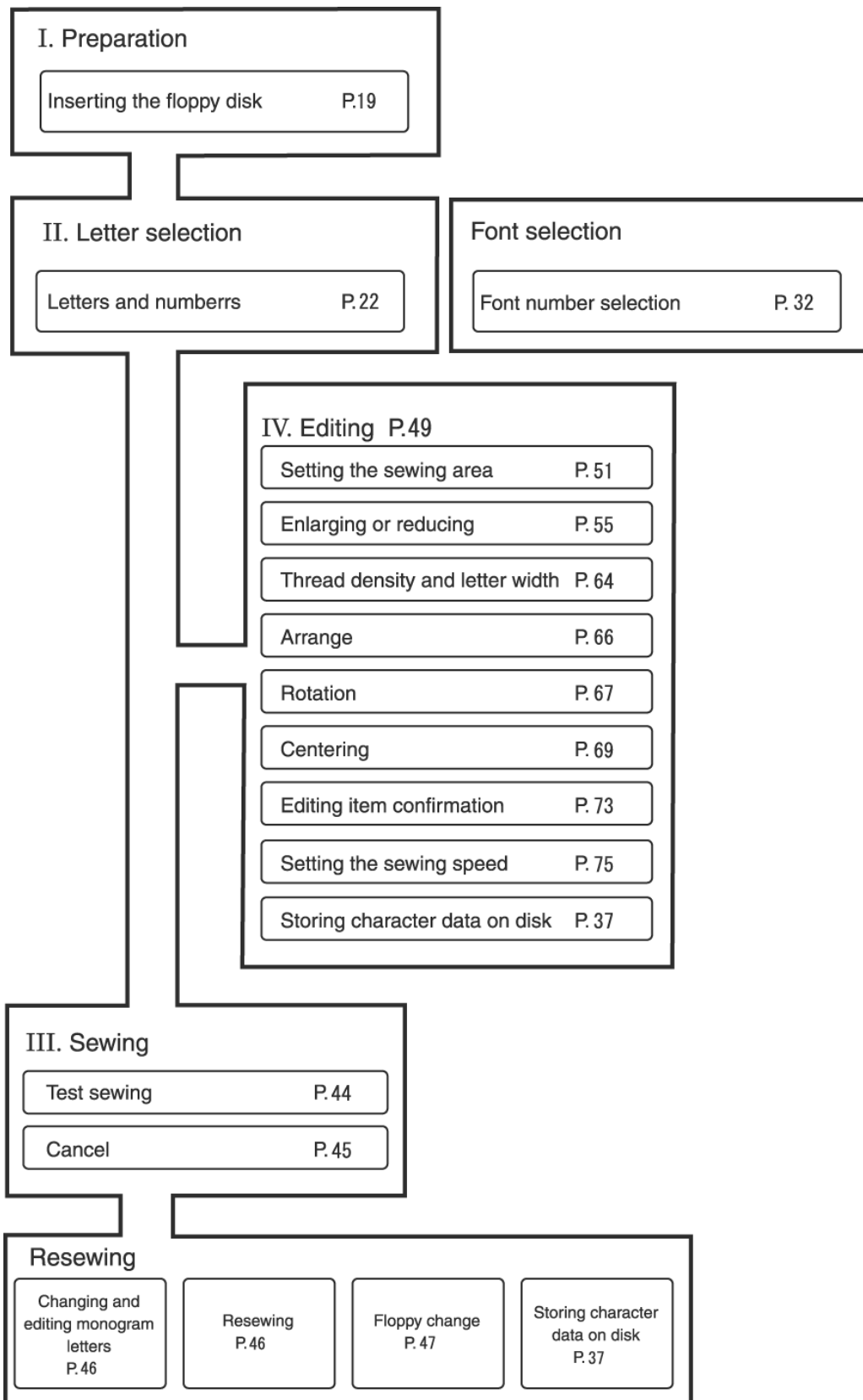

H0685

3-2. Operation panel part names and functions

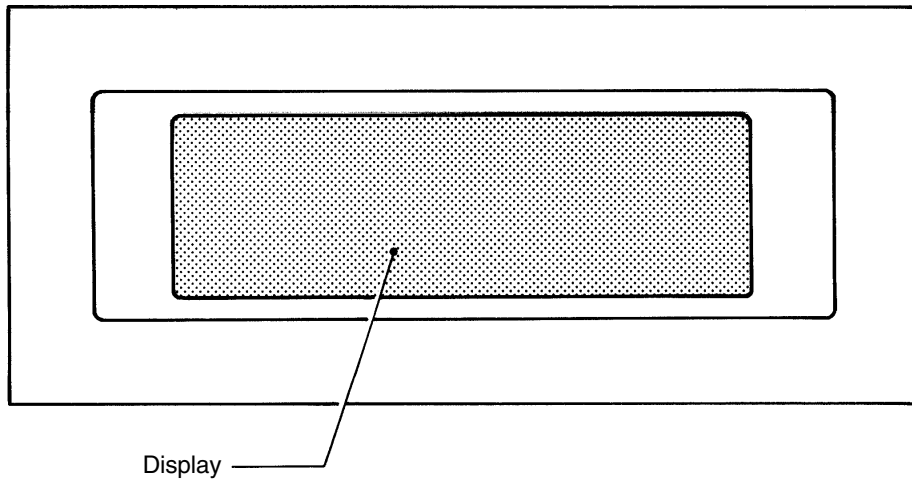

H0303

Display

The display shows messages, error codes, and other prompts, the selected monogram letters, editing menus, and other items on a 30 character (8 x 8 dots) display.

Display contrast control

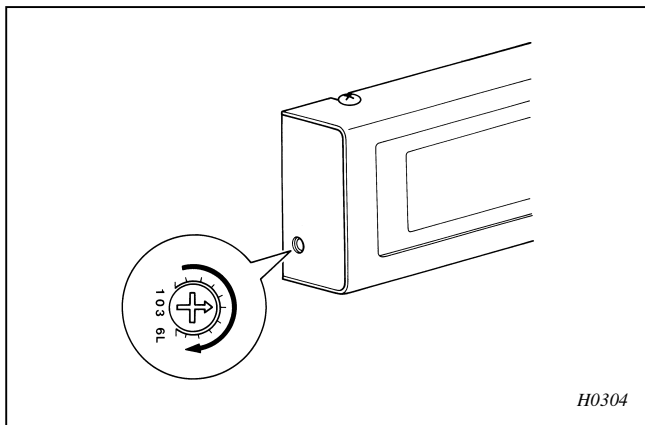

H0304

Used to make it easier to read the letters on the display.

(NOTE) Adjust the display after turning the power switch on. [Attention moving] will be displayed, followed by [No Floppy Disk].

Operation panel

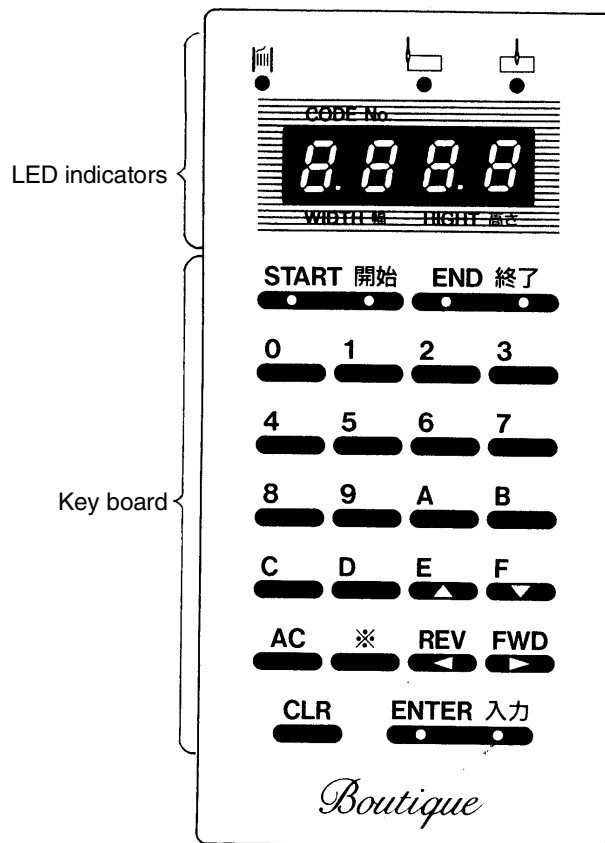

H0305

LED indicators

The text (2 letters or numbers) entered with the character code, and the enlargement/reduction size ratio (letter width and height) are displayed.

* The letters A, E, and F will always be displayed in upper case, and B, C, and D will always be displayed in lower case.

Keyboard

START key



H0306

Used to start sewing after selecting the monogram letters, and to select the sewing mode.

Used for editing after setting the font number.

END key



H0307

Used to edit after selecting the letters.

Used to sew after setting the font number or editing.

Used to cancel a change in the sewing pattern, test operation, or changes in floppy disk settings.

Used to terminate the enlargement and reduction ratio mode.

Number keys



Used to enter the character code.

Used to select the editing task number and to enter edit task settings.

Used to select letter enlargement or reduction (ratio and dimensions).
Numeric key "1" is used to set the sewing speed when in sewing standby mode.

Numeric key "2" is used to wind the bobbin thread when in sewing standby mode.

Letter keys



Used to enter character codes.

(E and F are also used as jog keys.)

Jog keys



Used to move the needle position in the direction of the arrow on the key.

(MEMO) While pressing the FWD (▷) key, turn on the power. The setting for DIP switch No. 8 will be reversed.

REV. and FWD. are used to move the cursor position on the display.

Also used to move the needle position one stitch at a time forward or back when resewing after thread breakage.



(MEMO) The jog keys (△ and ▽) are used to move the needle position at the sewing start forward or backward by 100-stitch blocks when restarting sewing after a thread breakage.

(MEMO) The jog keys can be used when editing with [1. Area] and [Designate point on upper left] and [Designate point on lower right] are alternately displayed, or when the needles start position is set before starting to sew and [Move needle to start point > ent] is displayed or [Move needle to start point > ent] and [Area over] are alternately displayed, or [Move needle to start point > ent] and [Sewing > start, Trace > *, Quit > end] are alternately displayed.

CLR key



Used to clear the letter over the cursor in the display.
Edited contents will remain unchanged.

Used to clear the LED Character code or to reset the ratio (letter width and height) to the standard (default) value in order to re-enable entry.

All clear key



Used to clear all letters on the display.

All edit contents will be automatically reset to the standard default values when <AC> is used.

Used to reset all edited contents to the standard values.

ENTER/FIX key



Used to convert character codes to letters.

Used when entering area, letter size ratio, font number, thread density and letter width, and the needle start point settings.

Confirm/test key



Used when winding the bobbin thread.

Used to confirm edit task contents.

Used when testing the sewing position of selected letters.

Used to determine why hollow letters are displayed.

Bobbin winding complete indicator



H0316

————— Illuminates to show that bobbin winding is complete.

Centering indicator

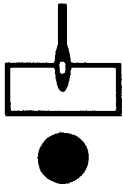

H0317

————— This means that the needle start point is in the center of characters or pattern.

Centering canceled indicator

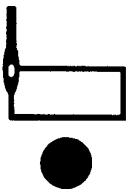

H0318

————— This means that the needle start point is to the left of characters or pattern.

3-3. DIP switch function

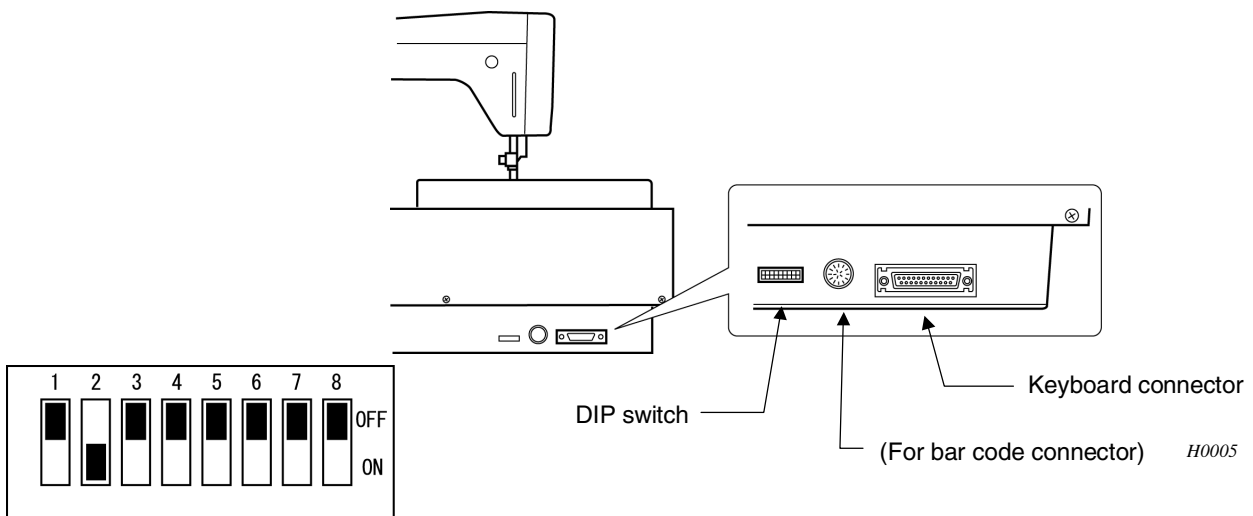

(MEMO) All DIP switches are set to OFF before delivery. (Excluding SW2)

DIP switch function		
SW	OFF	ON
1	Needle thread breakage detector activated.	Needle thread breakage detector deactivated.
2	---	Keyboard activated.
8	Brother disk mode	Tajima TFD mode.

3-4. Floppy disk

Notes on usage

Do not carelessly open the disk shutter and touch the electromagnetic face.



H0319

Do not store the disk in a location that is subject to temperature extremes.

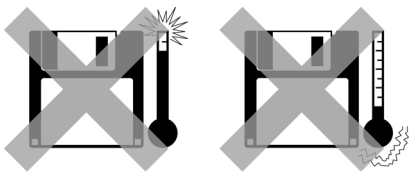

H0321

Do not store or use the disk in a dusty location. Do not place the disk directly on a cloth.

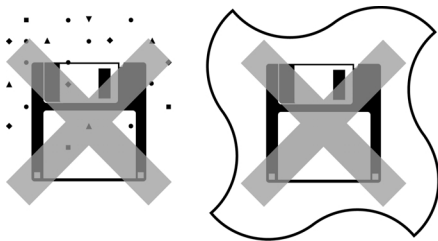

H0323

Do not bend the disk or place objects on top of it.



H0325

Protect the disk from damage and dust by returning it to the case after use.

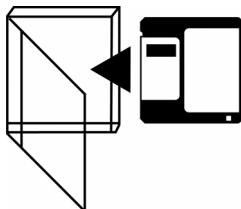

H0327

Keep items with a magnetic charge, such as magnetic drivers, away from the disk.



H0320

Do not use the disk in a damp location.



H0322

Do not store the disk in direct sunlight.

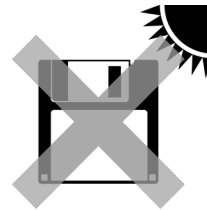

H0324

Do not let the disk come in contact with solvents, beverages, or other liquids.



H0326

Use a commercially available cleaning disk to clean the floppy disk head regularly.



H0328

Do not remove the floppy disk when the floppy disk access lamp is turned on.

Inserting the floppy disk

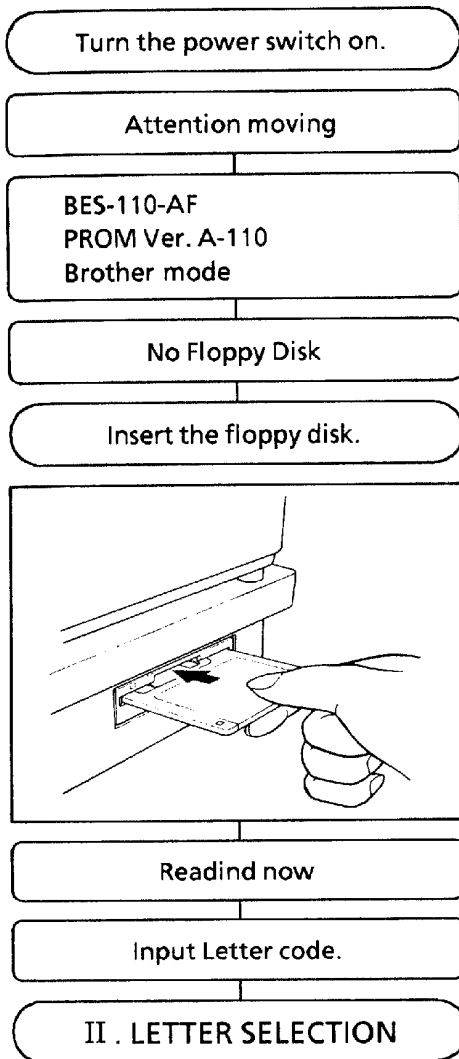

H0624

Removing the disk

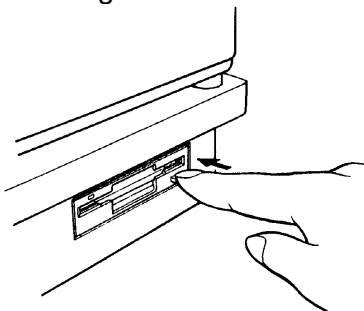

H0330

1. The display will come on when the power switch is turned on.

An alarm will beep four times, and the needle will be positioned at the center of the embroidery hoop.

2. Insert the Alphabet floppy disk.

- *1 It will not be possible to read or write to disk, and drive or disk problems may result if the disk is not properly inserted.
- *2 Floppy disks are a magnetic storage medium. The data on the disk can be easily damaged by magnetism, and the disks should therefore be kept away from magnets, televisions, telephones, and other products which may produce a magnetic field. Floppy disks should not be brought near the slide plate since it has a magnet on its back.

Displayed when the floppy disk drive indicator goes out.

- * [Input Letter code] will be displayed if in the default settings mode. If the letters have been set, the entered letters will be displayed.

Press the eject button. The disk will pop out, and [No Floppy Disk] will be displayed. Do not try to eject the disk while the floppy disk drive indicator is on.

- *1 If the power switch is turned on when the needle is lowered, [Turn pulley] will be displayed and an alarm will sound. After turning the pulley, [Press start key] and [Attention moving] will be alternately displayed, and the alarm will continue to sound. Press <START>.
- *2 If the power switch is turned on after the Alphabet disk is inserted, [Reading now] will be displayed, followed by [Input Letter code].
- *3 If the power switch is turned on after the memory disk inserted, or if the memory disk is inserted first after the power switch is turned on, [Replace with Alphabet F. D.] will be displayed. Insert the Alphabet disk.

3-5. Connecting a keyboard and entering characters

Characters can be entered using a keyboard, to the sewing machine. Note that there are some keys which are only operable on the sewing machine operating panel.

Connecting keyboard

1. Keyboard selector

Set the keyboard selector (1) to the keyboard (A or B) used.

[For German, Finnish, Norwegian, and Swedish]

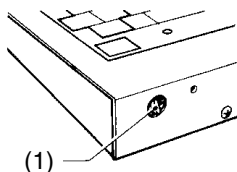

Keyboard A

H0532

[For French, Spanish, and Italian]

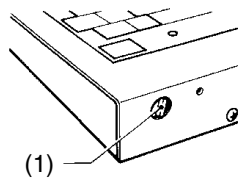

Keyboard B

H0533

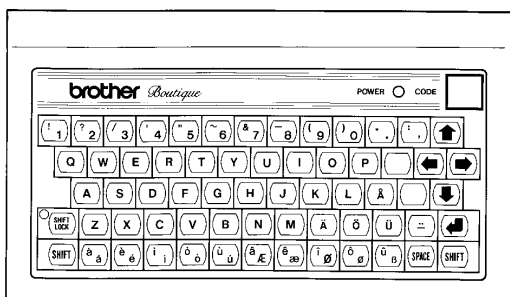

H0534

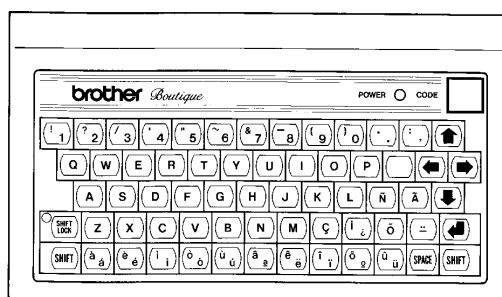

H0535

2. Connecting the keyboard to the machine

Turn the power switch on the sewing machine off.

(NOTE) Do not turn the power switch off until the floppy disk drive indicator goes out. See the figures below. Make sure that SW2 of the DIP switchpack is turned ON.

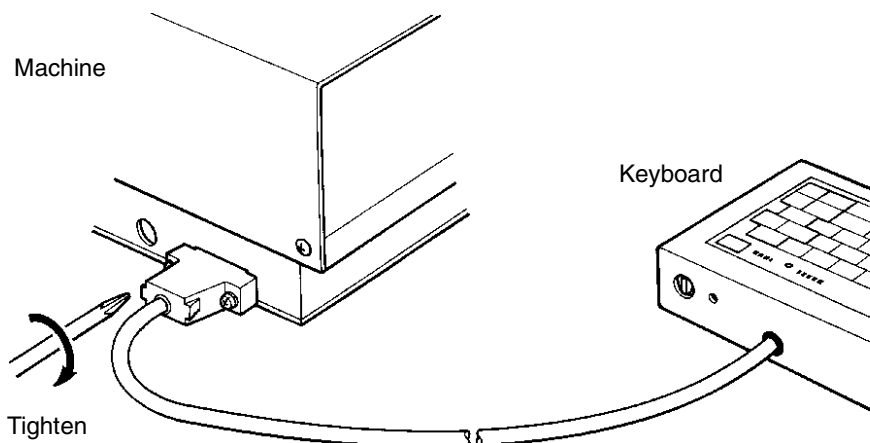

H0536

Entering letters

Letters can be entered from the keyboard to the machine only when the machine is in the character entry mode.

Power switch ON.

See page 20. Insert the floppy disk.

Input Letter code.

Characters can now be entered using the keyboard.

Those letters shaded in the figure below can be used.

After ending character entry from the keyboard.

After entering the letters, press <START> to proceed immediately to font selection and sewing, or press <END> to proceed to font selection and editing.

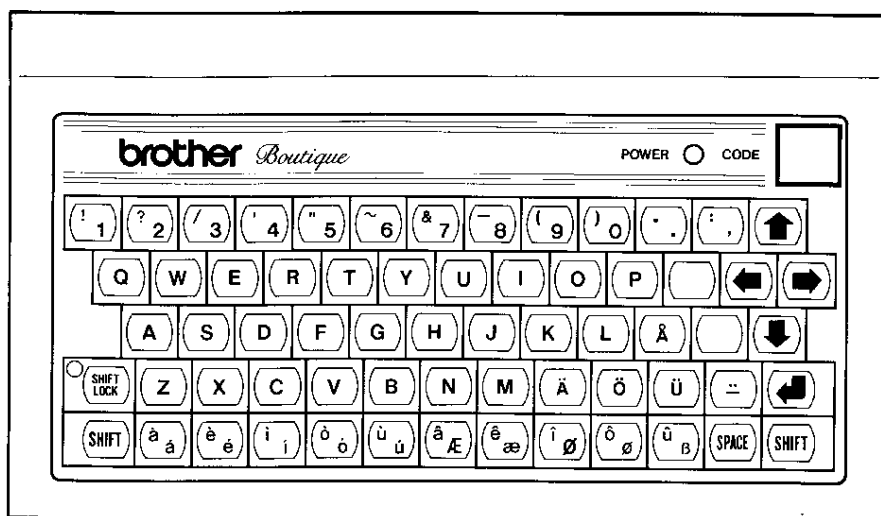

H0534

Capitals, symbols, and other characters in the upper left corner of each key can be entered using the SHIFT key. Lower case letters, numbers, and other characters in the lower right corner of each key can be entered normally.

(NOTE) Characters cannot be entered using the keyboard unless the is in the character entry mode.

(NOTE) A maximum of 30 characters can be displayed.

4. Sewing Procedure

4-1. Alphanumerics (upper and lower case letters, numbers)

There are 28 fonts both upper and lower case, and numbers which can be selected for sewing. Enter the letters and numbers to be embroidered using the keyboard.

Example 1 Enter the letters AB to be monogrammed.

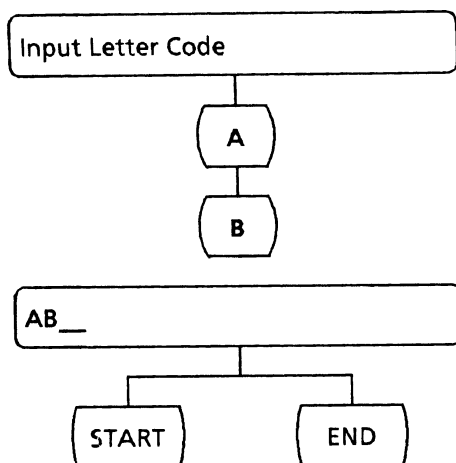

H0625

1. Press <SHIFT LOCK>.
2. Type <A> and on the keyboard.

[AB] will appear in the display.

3. After entering the letters, press <START> to proceed immediately to font selection and sewing, or press <END> to proceed to font selection and editing.
<START> and <END> switches are mounted on the panel of the machine.

Refer to the standard table for alphanumeric codes.

- *1 If hollow letters are displayed, move the cursor on the hollow character, and press <CLR> to delete the entry. Either there is no data entered for those letters, or there is a disk error. Move the cursor to the hollow letter, and press <※>. The cause of the problem will be shown.
 - *2 A maximum of 30 standard size characters can be displayed at one time.
- (NOTE) If you start sewing using data starting with ↵, ↑, ↓, ←, → incorrect positioning will be performed; please make sure data is correct before starting.

4-1-1. If "Area over" is displayed

If the position of the needle start point is incorrect when sewing starts, this may cause the pattern to extend outside the sewing area which has been set. In such a case, "AREA OVER" will be displayed. Press the <Δ>, <◁>, <▷> and <▽> jog keys to move the needle position so that the pattern falls properly within the sewing area.

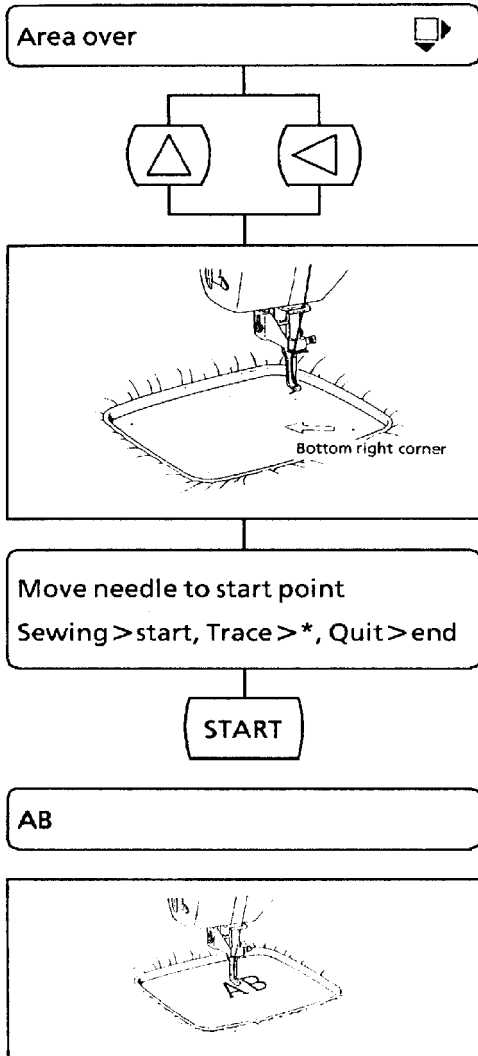

H0627

1. Alternately displayed.
The area is overrun in the directions indicated by the arrow (s).
(NOTE) The current needle position is at the bottom right corner.
2. Press jog keys <Δ> and <◁> to move the needle position in the direction opposite to the arrows <◁>.
(NOTE) The actual needle start position will vary with the lateral/vertical, rotation, and centering settings of the monogram.
3. The alternating displays will stop when the needle position is moved to a position where sewing is possible.
(NOTE) If the jog keys are pressed for too long, the area may be overrun in a different direction, and different arrows will then be displayed.
4. Press <START> and select [Sewing].
AB will be displayed and sewing will start. See page 42.

4-1-2. If "Short of area" is displayed

This message will be displayed if the total sewing size is greater than the sewing area. Use the following procedure when [Short of area] is displayed.

Short of area 
Check area>*, Clear display>end

The edit contents can be confirmed.
This appears when the monogram will not fit inside the sewing area.

※

1. Press the confirm key. The edit contents will be successively displayed.

Area: Wid. 050mm Hig. 080mm
AB: Width 030 mm Height 120 mm

Vertical and lateral dimensions of the sewing area
Vertical and lateral dimensions, rotation, total length (lateral and vertical)

END

2. Press <END>.

1 Re-input letter 2 Re-edit

3. Press <2> to select [2 Re-edit].

2

1 Area 2 Sizing 3 Dnsty/Thckns
4 Arrange 5 Rotation 6 Center

The edit menus will be alternately displayed.
Select edit item to change the desired setting.

H0628

- (NOTE) When the sewing area is reset ("1 Area" is selected), it should not exceed the embroidery hoop size. Refer to page 51.
- (NOTE) When "2 Enlarge or Reduce" is selected, characters can be enlarged by specifying the ratio and automatically calculating the total length. Refer to page 55.
- (NOTE) When "5 Rotation" is selected, reset the rotation angle so that the character is positioned within the set area.

4-1-3. Correcting a letter

Input characters can be changed in the text entry mode.

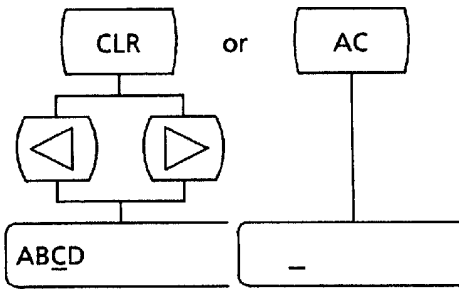

H0629

1. Press <CLR> or <AC>.

To clear a character with <CLR>, use the jog keys to bring the cursor under the character to be deleted, and then press <CLR>.

All characters displayed will be deleted when <AC> is pressed. Re-enter desired characters.

All settings other than monogram area setting will be reset to the default settings when <AC> is pressed.

Input characters can be changed in the text entry mode.

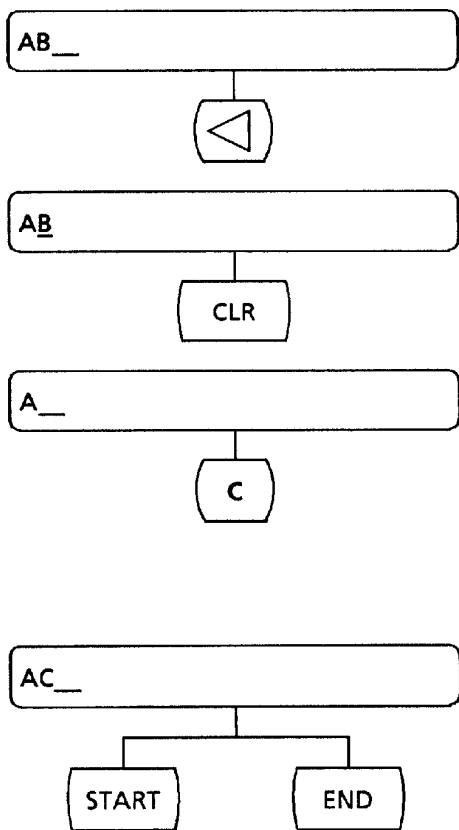

H0630

Ex. Change AB to AC

1. Press the jog key <<>. The cursor will move under the B.
2. Press <CLR>. The B over the cursor will be deleted.
 - * Pressing <AC> will delete all displayed letters.
3. Enter C from the keyboard. [C] will be displayed. The change to [AC] is completed.
4. Press <START> to proceed with sewing or <END> to edit.

4-2. Setting the letter spacing

Entering the space ($\rightarrow\leftarrow\uparrow\downarrow$) codes will shift the letters 1 mm each in the direction of the arrow. Changing the enlargement and reduction ratio can also change the spacing of each arrow from 0.1 - 9.9 mm.

To shift the letters more than 9.9 mm

Simply enter multiple arrows and change the ratio as required.

For example, to shift the letters AB 15 mm apart, insert two arrows (1) and (2) $A\rightarrow\rightarrow B$, and specify an enlargement of 7 times for arrow (1), 8 times for arrow (2). Since $7 + 8 = 15$, the letters will move 15 mm apart.

Reduce the lateral spacing between A and B

[Space code key]

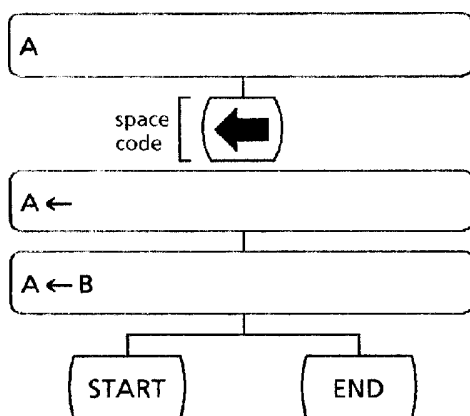

H0539

1. Enter <A> from the keyboard.
2. Press the space code key.
3. Enter from the keyboard.

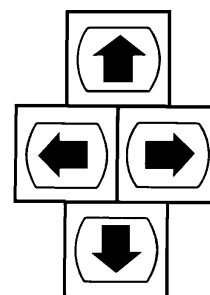

H0540

A ← B is entered.
Press <START> to proceed with sewing, <END> to edit.

- * To increase letter spacing, enter space code $\leftarrow\rightarrow$ in step 2 above.
- * Press <START> to sew. See page 42.
- * If an enlargement or reduction ratio is set and the arrow key is pressed in the input mode, the space code will not be set to the default value. See page 55 for individual settings.

To change the spacing between letters

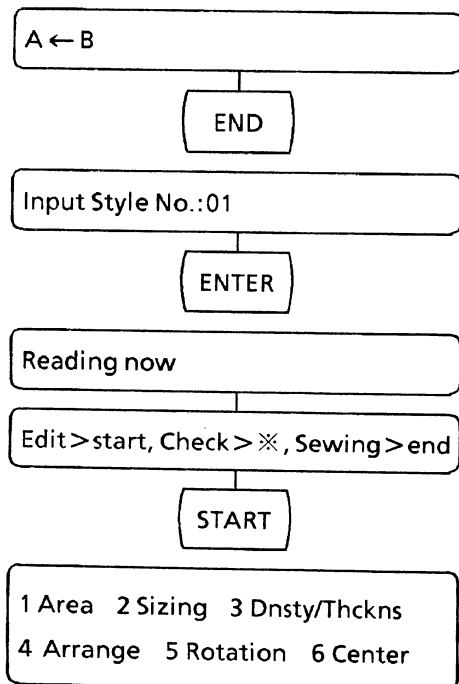

H0631

Set the spacing between A and B to 1.2 mm.

1. Press <END>.
2. Press <START>.
3. Press <2> to select [2. Sizing].
Press <2> on the sewing machine operation panel.

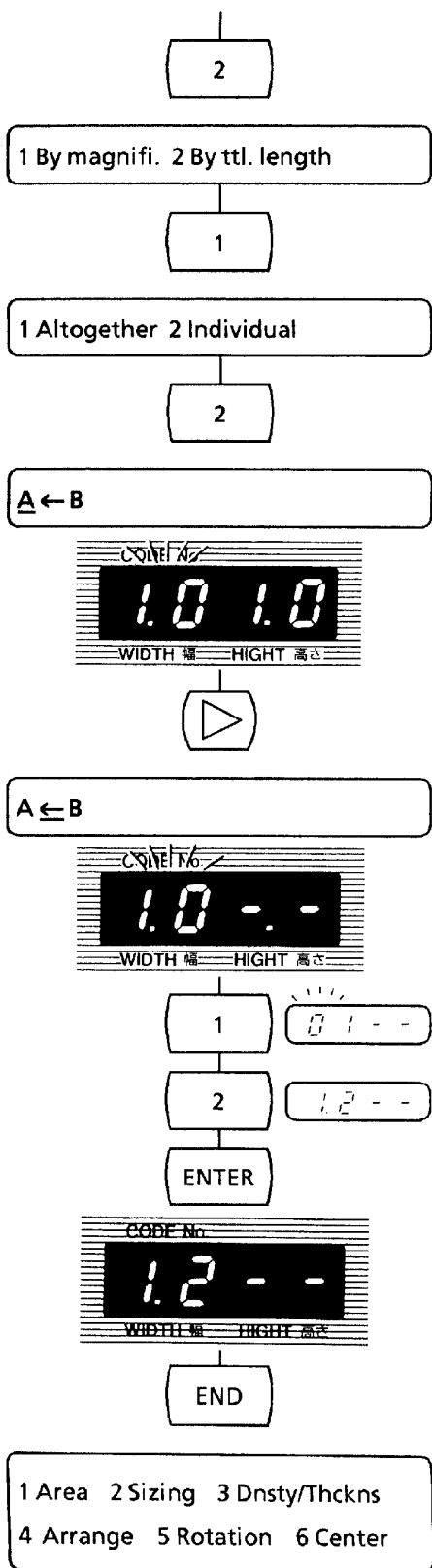

Use the operation panel on the sewing machine to enter the edit contents.

4. Press <1> to select [1. By magnify].

5. Press <2> to select [2. Individual].

If a different ratio has already been set, that ratio will be shown in the blinking LED.

6. Press the jog key <FWD>. The cursor will move under the <←>, and the width ratio [1.0] for the space code will be displayed with a blinking LED.

7. Enter the numbers [1] [2]. The width ratio [1.2] for the space code will appear on the blinking LED.

8. Press <ENTER>. The width ratio [1.2] for the space code will be entered.

9. Press <END>. The size of the space code <←> will be saved. The edit menu will be alternately displayed.

10. To proceed with sewing, press <END>.

H0541

Letter spacing greater than 9.9 mm (15 mm in this example)
 Use the operation panel on the sewing machine to enter the edit contents.
 Set the spacing between <A> and to 15 mm.

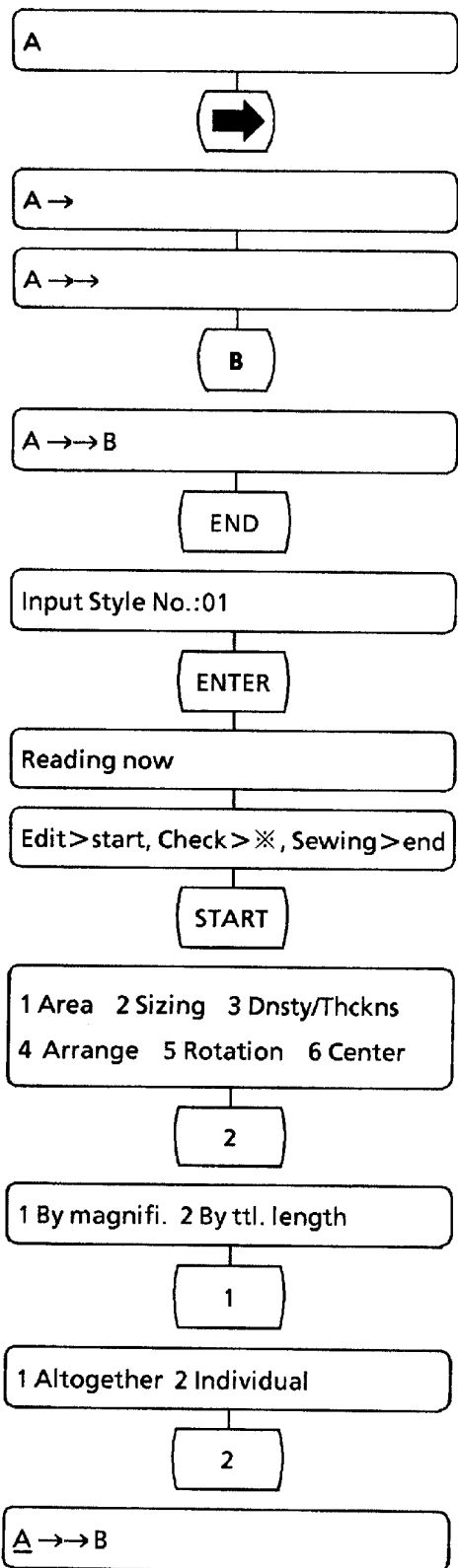

H0543

1. Enter <A>, and then press the right <→> space code key.
 <→> will be displayed.
 The first left space is entered.
2. Again press the right <→> space code key.
 <→> will be displayed.
 The second left space is entered.
3. Enter from the keyboard.
 The B is entered.
4. The size of the <→> is to be change. Press <END> to enter the edit mode.
5. Press <ENTER>.
6. Press <START> and select the edit mode.
 The edit menus will be alternately displayed.
7. Press <2> to select [2. Sizing].
8. Press <1> to select [1. By magnify].
9. Press <2> to select [2. Individual].

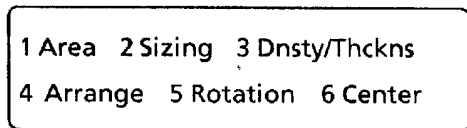
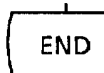
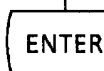
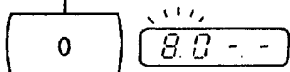
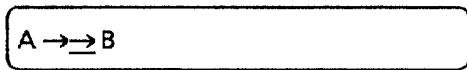
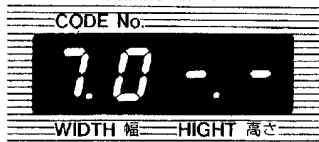
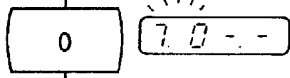
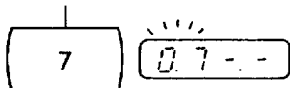

H0632

* If a different ratio has already been set, that ratio will be displayed.

10. Press the jog key <▷>. The cursor will move under the <→>, and the width ratio [1.0] for space code will be displayed.
11. Enter the numbers [7] [0]. The width ratio [7.0] for the space code will be displayed.
12. Press <ENTER>. The width ratio [7.0] for the space code will be entered.
13. Press the jog key <▷>. The cursor will move under the second <→>, and the width ratio [1.0] for the space code will be displayed.
14. Enter the numbers [8] [0]. The width ratio [8.0] for the space code will be displayed.
15. Press <ENTER>. The width ratio [8.0] for the space code will be entered.
16. Press <END>. Press <END> to proceed with sewing.



The width of the first space code is now 7.0 mm, and the second space code is 8.0 mm, enabling the B to be shifted a total of 15 mm. The edit menus will be alternately displayed. To confirm the edit contents, press <※>. See page 73. To sew, press <END>. See page 42.

4-2-1. Space codes and sewing position

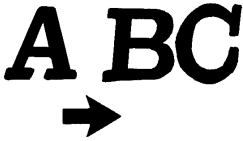
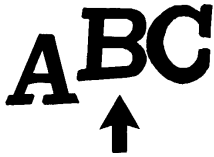
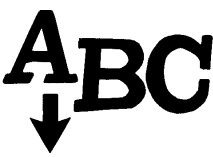
If ABC is set laterally

Space code	1F	1E	1C	1D
Display	A←BC	A→BC	A↑BC	A↓BC
Sewing position	 <i>H0367</i>	 <i>H0368</i>	 <i>H0369</i>	 <i>H0370</i>

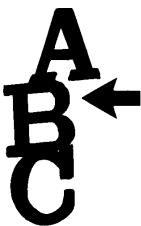
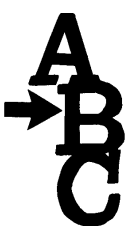
If ABC is set vertically

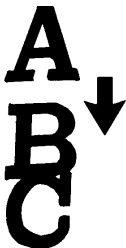
Space code	1F	1E	1C	1D
Display	A←BC	A→BC	A↑BC	A↓BC
Sewing position	 <i>H0371</i>	 <i>H0372</i>	 <i>H0373</i>	 <i>H0374</i>

Applications

The following alignments and monograms can be sewn by entering various space codes.



4-3. Pause

When pause symbol (*) is entered between characters, embroidering is suspended.

A * B

Re-start > start, Quit > clr

START

Sewing resumes.

H0633

Enter a pause symbol (*) in front of the character that you want to suspend embroidering for.

Embroidering is suspended before the letter "B" is embroidered, and the indication shown in the left figure, will appear.

Press <START> to start embroidering the letter "B".

- * The asterisk code is <2A>.
- * "*" is displayed on the machine by pressing the pause key  on the keyboard.

4-4. Carriage return

Brother Mike

(With centering)

**Brother
Mike**

(Without centering)

**Brother
Mike**

H0544









In the text entry mode enter the carriage return before the letter which is to start the next line.

The carriage return code is <7F>.

(NOTE) If you start sewing using data starting with ↵, ↑, ↓, ←, →, incorrect positioning will be performed; please make sure data is correct before starting.

4-5. Selecting fonts for letters and numbers

Different fonts can be selected after entering the letters (upper or lower case) and numbers.
 There are 28 fonts available.
 Set the font code using the operation panel on the sewing machine.
 Normal scaling up or down (0.1 to 9.9 times) is available.

 Font code 01 <small>H0546</small>	 Font code 02 <small>H0547</small>	 Font code 03 <small>H0548</small>	 Font code 04 <small>H0549</small>
 Font code 05 <small>H0550</small>	 Font code 06 <small>H0551</small>	 Font code 07 <small>H0552</small>	 Font code 08 <small>H0553</small>
 Font code 09 <small>H0554</small>	 Font code 10 <small>H0555</small>	 Font code 11 <small>H0556</small>	 Font code 12 <small>H0557</small>
 Font code 13 <small>H0558</small>	 Font code 14 <small>H0559</small>	 Font code 15 <small>H0560</small>	 Font code 16 <small>H0561</small>
 Font code 17 <small>H0562</small>	 Font code 18 (*) <small>H0563</small>	 Font code 19 (*) <small>H0564</small>	 Font code 20 <small>H0565</small>
 Font code 21 (*) <small>H0566</small>	 Font code 22 <small>H0567</small>	 Font code 23 (*) <small>H0568</small>	 Font code 24 (*) <small>H0569</small>
 Font code 25 (*) <small>H0570</small>	 Font code 26 (*) <small>H0571</small>	 Font code 27 (*) <small>H0572</small>	 Font code 28 (*) <small>H0573</small>

(*) This font is available only in capital letters.

4-5-1. To embroider the letters



H0547

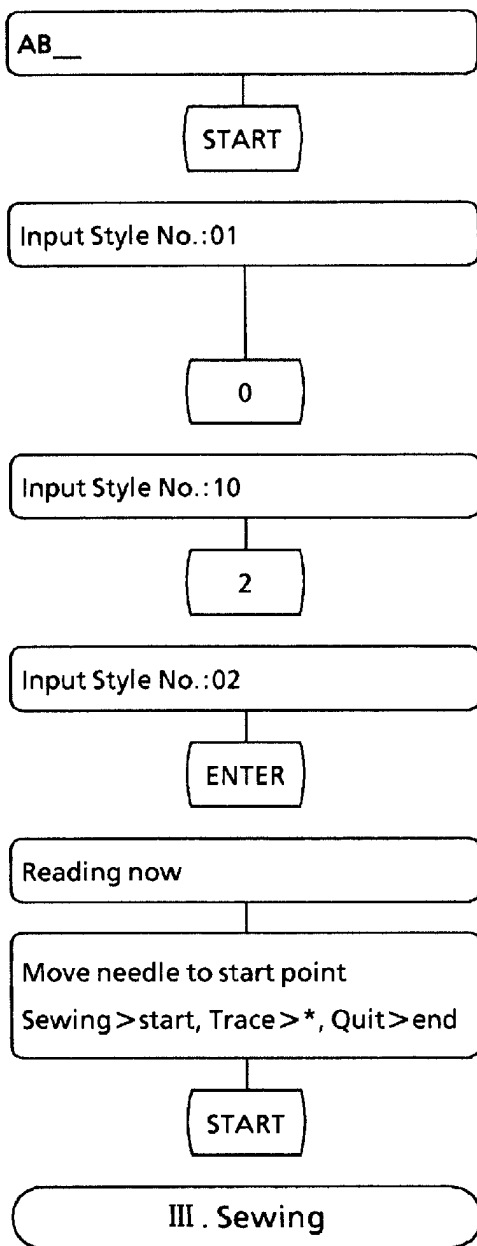

1. Press <START>. Font number <01> will be displayed.
*1 Font number <01> is displayed in the default setting mode.
If a different font has been specified, that font number will be displayed.
*2 The font number is always a two-digit number.
2. Press <0>. The <1> will be carried to the upper digit, followed by <0>.
3. Press <2>. The 0 will be carried to the upper digit, followed by 2.
4. Press <ENTER>. The AB monogram will be set to font number <02>. Shown while the floppy disk drive indicator is on.
Shown while the floppy disk drive indicator goes out.
* The current needle position is the needle start position.
5. Use the jog keys to set the needle start position, and then press <START>.



→ P. 42

H0634

4-5-2. Letter monogram specifications (optional)

Data arrangement and sewing start position

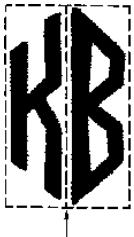
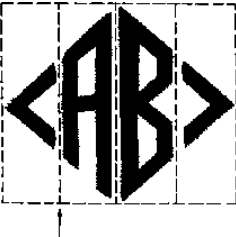
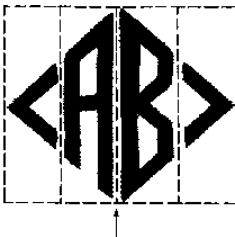
The arrow in the figures below indicates the sewing start position.

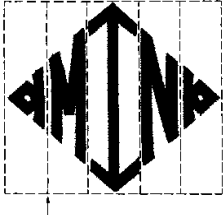
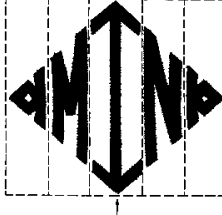
2 Letter			
No decoration		With decoration	
Centering OFF	Centering ON	Centering OFF	Centering ON
			
<i>H0574</i>	<i>H0575</i>	<i>H0576</i>	<i>H0577</i>
3 Letter			
No decoration		With decoration	
Centering OFF	Centering ON	Centering OFF	Centering ON
			
<i>H0578</i>	<i>H0579</i>	<i>H0580</i>	<i>H0581</i>

If you want to change fonts from the one used on the current floppy disk to another one; turn off the power, replace the floppy disk with another one, and turn on the power again.

To sew without additional decoration

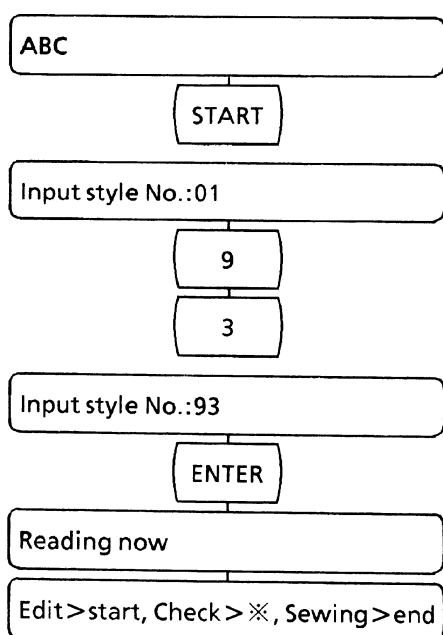

H0635

1. Enter ABC from the keyboard in the text entry mode.
2. Press <START>.
3. Enter the 3 letter code using the key panel. Press<9>, <3>.
Enter <9> <2> for two letters, or <9> <1> for one letter.

4. Press <ENTER>.

Decorative marks	"	⬡	mark
	!	< >	mark
	&	⊙ ⊙	mark

(NOTE) These decorative marks should be entered at the end of the text.

5. Set the needle start position with the jog keys.

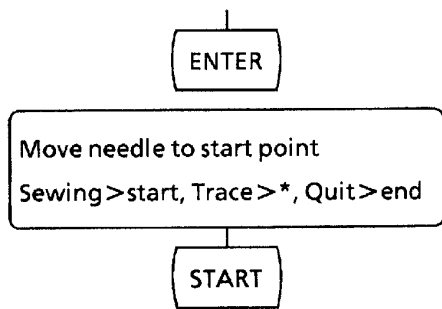

H0639

6. Press <ENTER>.
7. Press <START>. Sewing start.

To sew with additional decoration

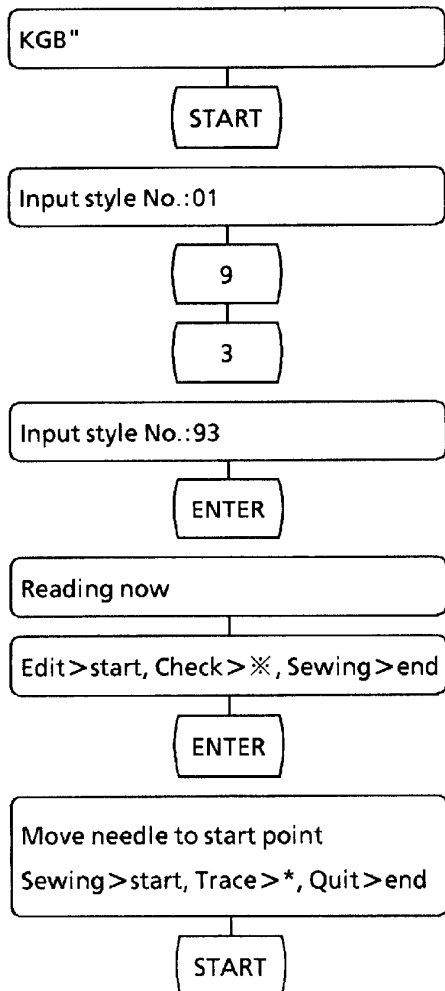

H0640

1. Enter the letters and bracket code <"> using the keyboard.
2. Press <START>.
3. Enter the 3 letter code using the key panel.
Press<9>, <3>.
For a two letter code, enter <9> <2> or <9> <1> for one letter.
4. Press <ENTER>.
5. Set the needle start position with the jog keys.
6. Press <ENTER>.
7. Press <START>. Sewing start.

- (NOTE) - Be sure to insert the dedicated three letter code disk (for sewing 1 to 3 letters) before entering the code.
An entry error will occur if font numbers 91, 92, or 93 are entered and the disk is not one for three letter codes.
There are cases in which an entry error may not be displayed. In this case, the correctly displayed letters will not be sewn and other letters will be instead.
- Be sure the number of letters entered and the font number match.
If, for example, only two letters are entered but the font number is 91 or 92, an entry error will occur or different letters will be sewn.
 - Only capital letters are stored on disks as three letter codes.
If lower case letters are used, but the correct disk for the three letter code is inserted, the font number is correct, and code 91, 92 or 93 is entered, letters other than those displayed may be sewn.

4-6 How to install Tajima floppy disk

(Note) Tajima floppy disk is a read-only disk, and you cannot update your edited data.

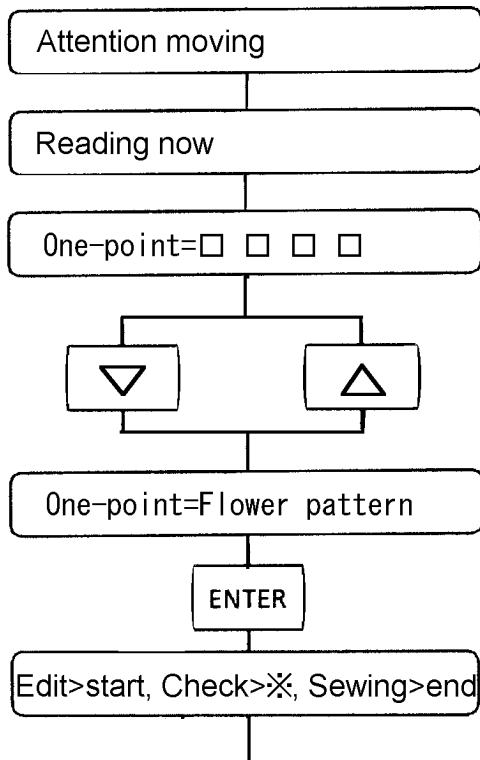

H0687

1. Turn the power off if the machine is on, and then set on SW8 of the DIP switchpack.
2. Turn on the power the machine.
3. Insert Tajima floppy disk.
A current pattern name is displayed.
4. Select a desired name using jog keys <▽><▲>. <▽>key goes a previous pattern name <▲>key goes a next pattern name
5. Press <ENTER>key.
6. Press <START>key to go the editing item selection (Refer to page 50), or Press <END>key to start sewing operation (Refer to page 22).

4-7. Storing character data on disk (creating a storage disk)

Patterns can be stored on 3.5 floppy disk.
 Up to 40 patterns can be stored on a single disk.
 Registration numbers for patterns are FF01 to FF40.
 Be sure to use Brother disks.

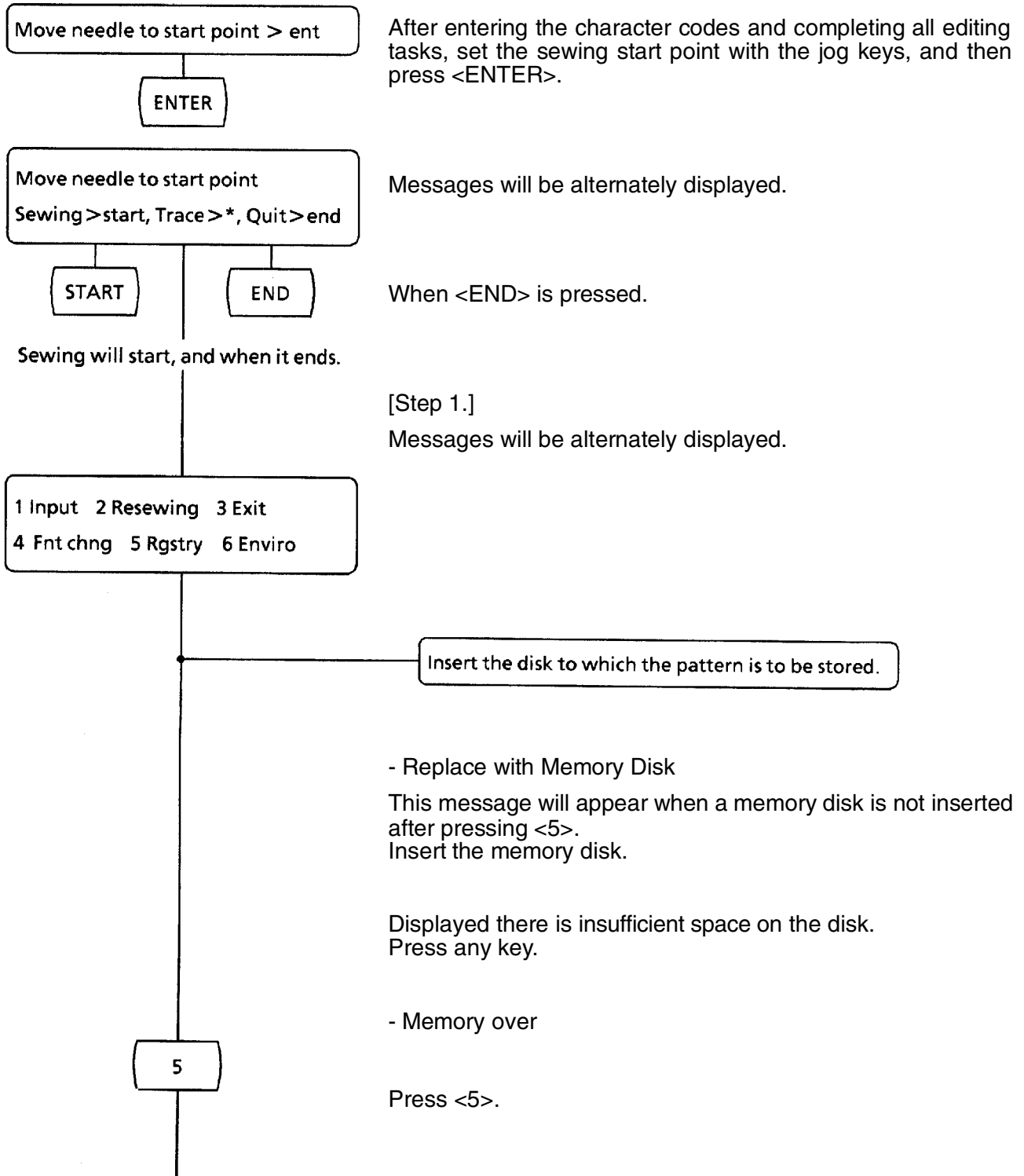

H0641

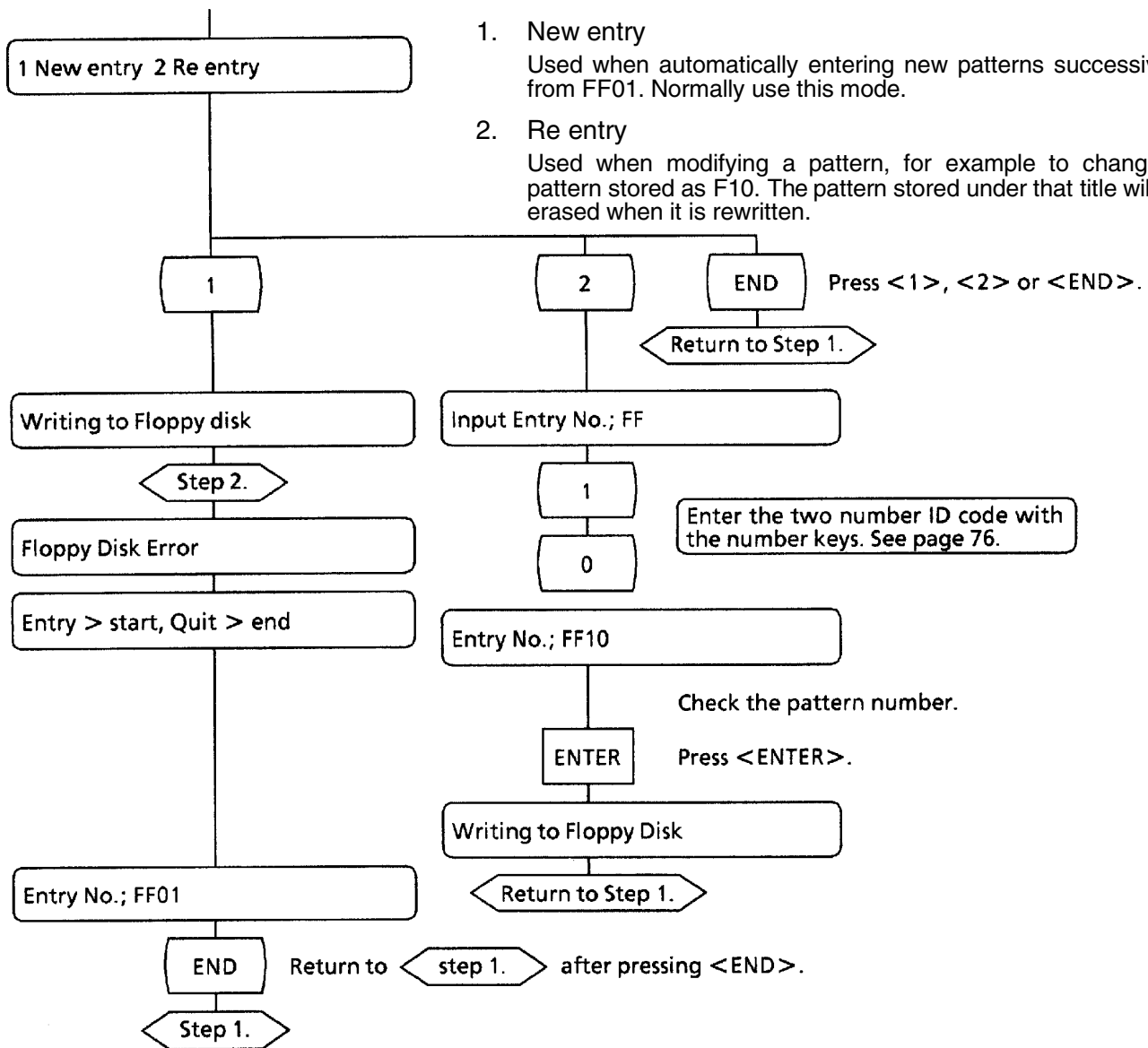

H0642

At [Step 2.]

Floppy Disk Error
Entry > start, Quit > end

These messages will be alternately displayed. Check the following and then press <START>.

(NOTE) A disk error will always be displayed the first time a new disk is used. Press <START> anyway. The disk will be automatically formatted and the pattern will be stored.

- | Check |
|---|
| 1. If the disk is protected, slide the protect tab up so that it covers the hole, and press <START>. |
| 2. If the disk is a Brother character data disk, replace it with a disk for pattern storage, and press <START>. |
| 3. If a disk for pattern storage is used for the first time, or if the disk has been used on a different system, press <START>. |
| 4. Pattern can not be stored other than in the above cases. Press <END>. |

4-8. Reading character data

At the text code entry step (See page 22.)

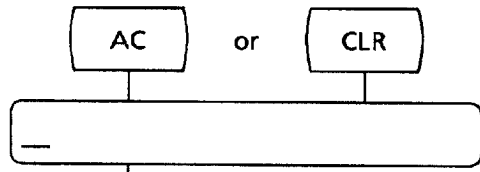

1. Press the <AC> or <CLR> key to clear the display. Display with no data.

Insert the memory disk with the sewing pattern.

Enter the registration number; <F-F-1-0>
In this example, enter "FF10" for number <FF10>.
<FF10> will be displayed.



2. Press <ENTER>.

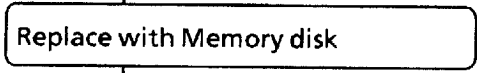

The pattern stored at that number will be read and displayed.



3. Press <START> or <END>.
This completed the pattern read operations.
Setting sewing data and sewing tasks is possible.

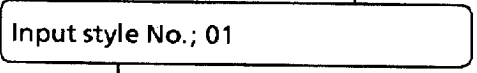

The sewing area will be set to that registered with sewing pattern.

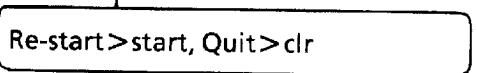
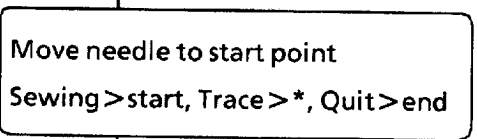

H0644

Example

To add new data (Ex. a name; "SMITH") to a previously stored pattern, e.g. BROTHER.
Use the operation panel on the sewing machine to enter the pattern code for the pattern to be read from the disk.

At the text entry step (See page 22.)

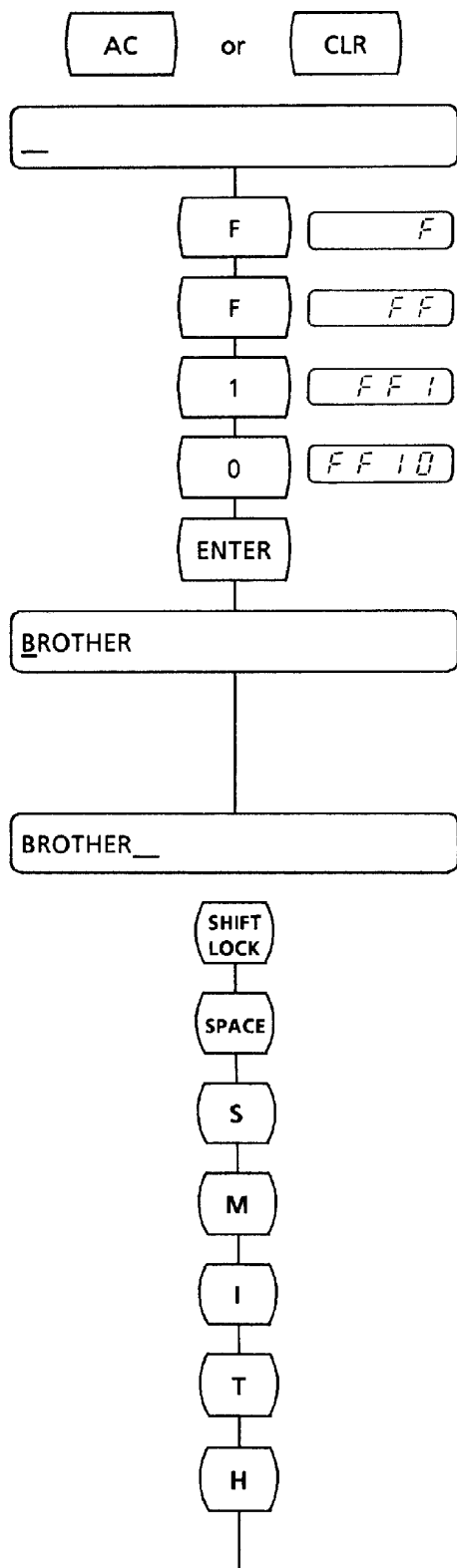

Press the <AC> or <CLR> key to clear the display.

Insert the disk containing the pattern to be used.

Enter the number of the pattern (assumed here to be FF10).
The registration number will be displayed: FF10.

Press <ENTER>.

Press <D> on the machine panel, and move the cursor to the right of "R".
The pattern stored under that name will be read.
To add new information (Ex. the name "SMITH") to existing data, use the keyboard.

Enter the letters for "SMITH".

Press <SHIFT LOCK>.

Press <SPACE>.

Press <S>.

Press <M>.

Press <I>.

Press <T>.

Press <H>.

H0645

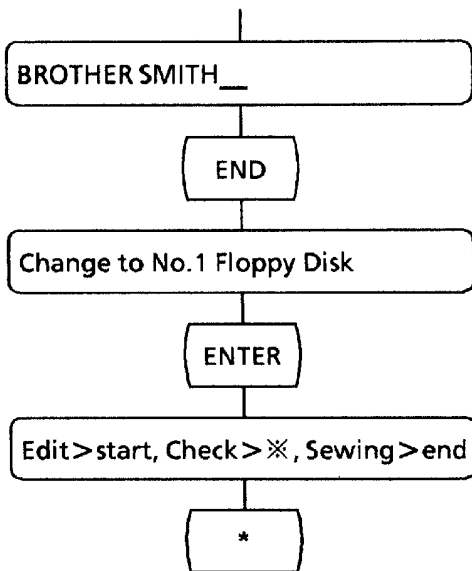

Press <END>.

This message will be displayed.
Remove the disk and insert disk 01.

When data stored in the memory disk has been enlarged or reduced in the individual size ratio mode, its edited contents should be reset. The appended data will be automatically set to the standard magnification; 1.0.

Press <※> to check the magnification and area before sewing.

H0646

If [Disk error] is displayed or blank characters are displayed after <END> is pressed, check if that disk is the desired data disk (disk No. 1), and then press <END> again.
If [Disk error] is still displayed, refer to error messages, page 80.

5. Sewing Function

5-1. Sewing

Sewing preparations

Insert the floppy disk and select the letters before starting to sew.

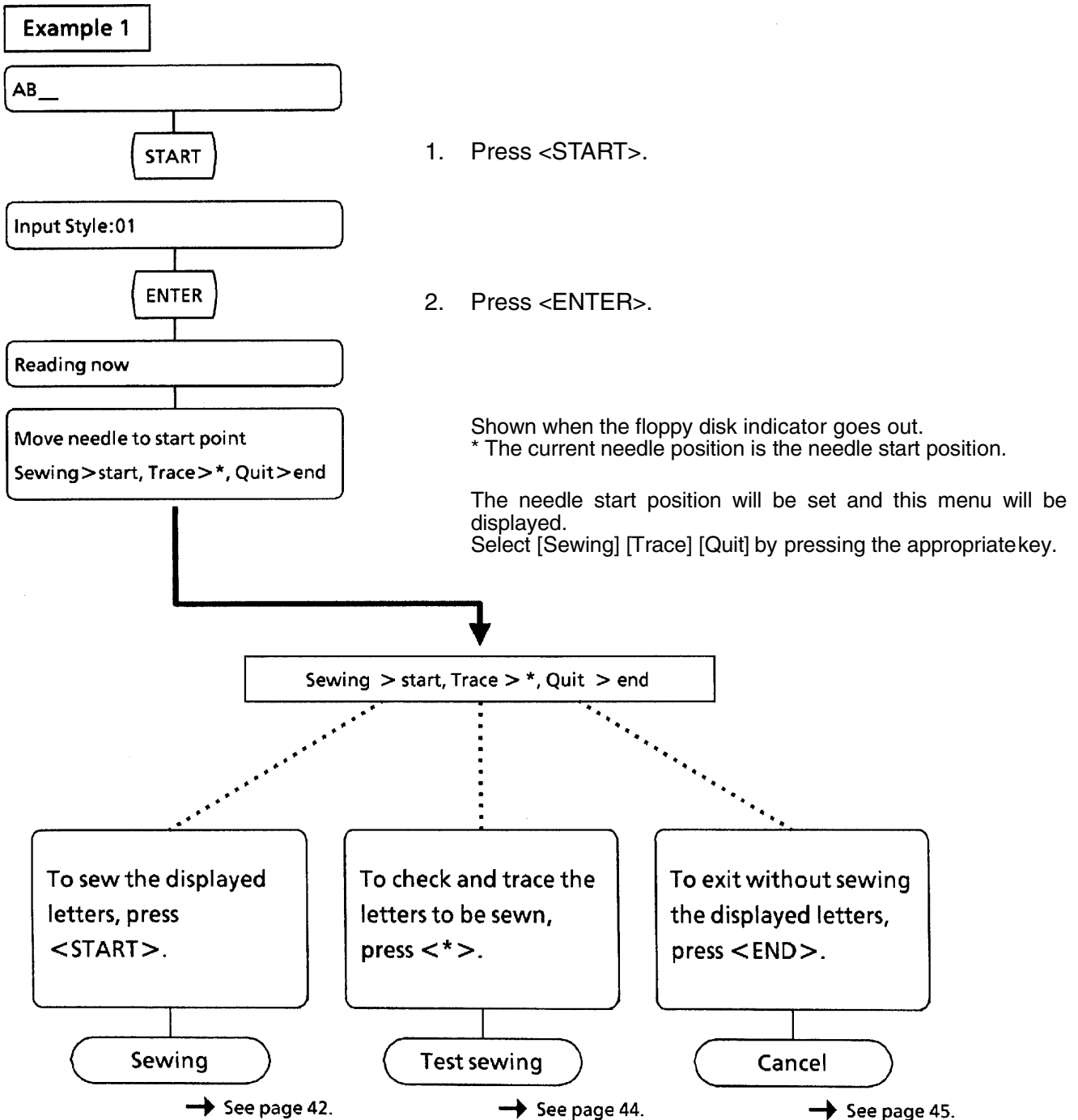

H0647

[Sewing start]

Sewing > start, Trace > *, Quit > end

START

AB

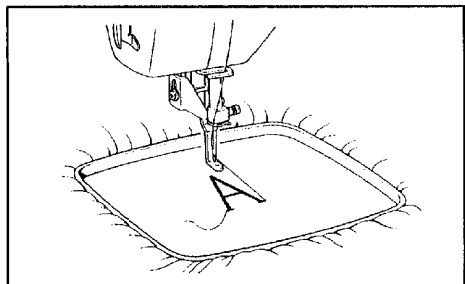

B

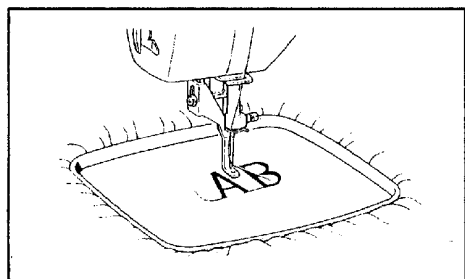

1 Input 2 Resewing 3 Exit
4 Fnt chng 5 Rgstry 6 Enviro

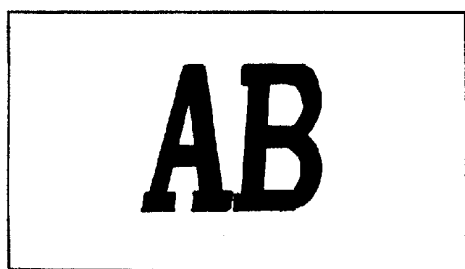

H0582

3. Press <START>, and select [Sewing].

A, B will be displayed, and sewing will start.

* Letters will be sewn in an order different from that actually written.

When the first letter, A, is completed, it will be deleted from the display.

When sewing is completed, the needle will return to the needle start position, and the indications shown on the left will be displayed alternately. Sewing of the monogram is now over.

To change the monogram letters, enter 1. (See page 46.)

To sew the same monogram again, enter 2. (See page 46.)

Press number key <4> on the operation panel on the sewing machine to use the optional design floppy disks. (See page 48.)

To save the data of characters that have been embroidered, press <5> on the operation panel. (Refer to page 37.)

- (NOTE)
- The selected letters and settings (or default) will remain selected after sewing is completed until the settings are changed by the operator.
 - The selected letters and settings will remain selected for about one week if the power switch is turned off.
 - If the thread breaks while sewing, [Thread breakage] and [Press end Key] will be alternately displayed, and an alarm will sound. [Re-start > start, Quit > clr] will be displayed when <END> is pressed. Rethread, return the needle to where the thread broke using the jog keys (REV., FWD.), and then press <START>.
 - If sewing is paused to change thread colors, or if the emergency stop function is used, press any key on the machine operation panel to resume sewing.

5-2. Test sewing

The size and position of monogrammed letters can be tested before actual sewing using the confirm/test key <✳>.

[Example 1] Monogram AB.

Move needle to start point
Sewing>start, Trace>*, Quit>end

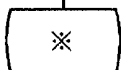

AB

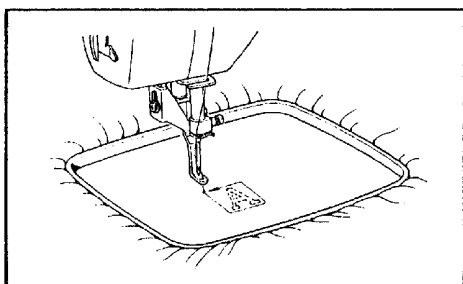

B

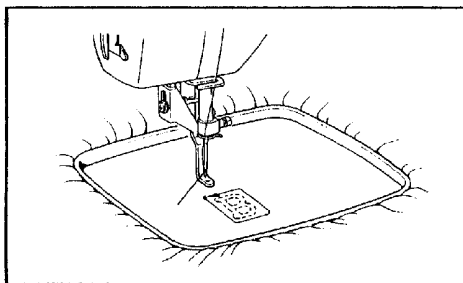

Move needle to start point
Sewing>start, Trace>*, Quit>end

H0585

1. Press the confirm/test key <✳> and select [Trace].

AB will be displayed and confirmation of the position of each letter will start.
The needle will trace around the area in which the <A> will be sewn.

When the first letter, <A>, is completed, it will be deleted from the display.
The needle will trace around the area in which the B will be sewn.

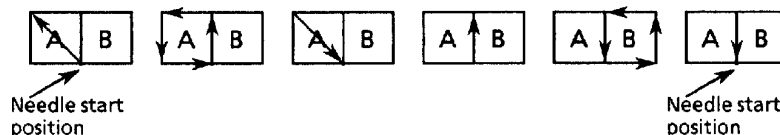

H0587

When tracing is completed, the needle will return to the needle start position, the indications shown on the left will be displayed alternately.

Confirmation of the pattern area is now completed.

To sew the monogram letters, press <START>. (See page 46.)

To exit without sewing the displayed letters, press <END>. (See page 46.)

To change the needle start position, select [Clear], press END, and then select [2. Resewing].

To change the letter size, select [Quit], press <END>, and then select [1. Input]. In the input mode, edit the letters to be sewn.

- (NOTE) - Only the embroidery hoop will move during confirmation of letter position.
- To stop letter position confirmation, press any key on the machine operation panel. The needle will return to the needle start position.

5-3. To change the sewing start position after test sewing

Move needle to start point
Sewing>start, Trace>*, Quit>end

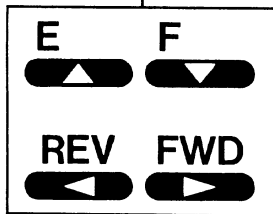

ENTER

These messages will be alternately displayed. Press the jog keys to move the needle to the new start position, and then set the sewing start position again.

Move needle to start point
Sewing>start, Trace>*, Quit>end

Use the jog keys to set the needle start position, and then press <ENTER>.

Press <✳> for test sewing. If sewing is OK after confirming the pattern with the test operation, press <START>.

H0648

5-4. Cancel

Sewing and the confirmation/test mode can be cancelled, and the monogram letters changes or modified.

To cancel and stop sewing or confirmation.

Move needle to start point
Sewing>start, Trace>*, Quit>end

END

1. Press <END> and select [Quit].

1 Input 2 Resewing 3 Exit
4 Fnt chng 5 Rgstry 6 Enviro

The same display which appears after sewing is completed will appear. Select [1. Input or 2. Resewing 3. Exit 4. Fut chng 5. Rgstry 6. Enviro].

H0649

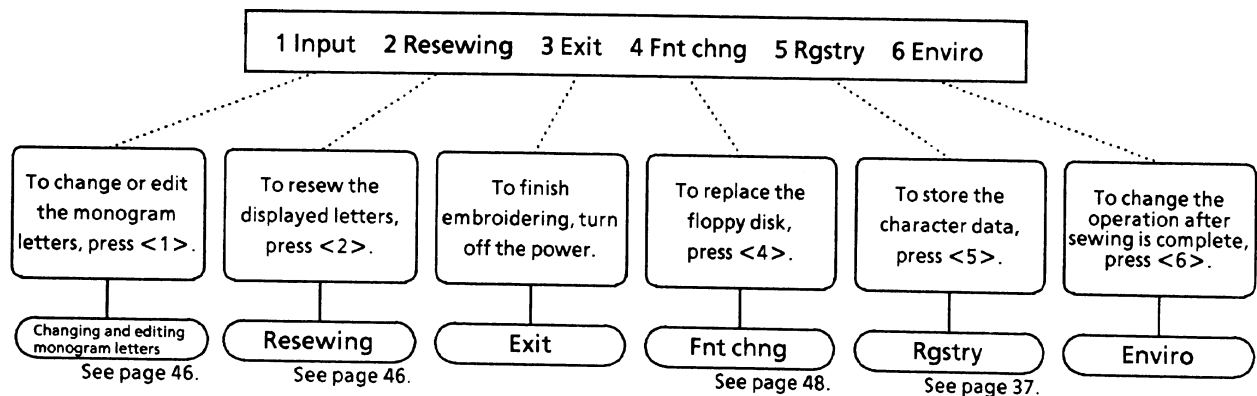

H0650

5-4-1. Changing and editing monogram letters

The monogram letters can be changed or edited after sewing is completed.

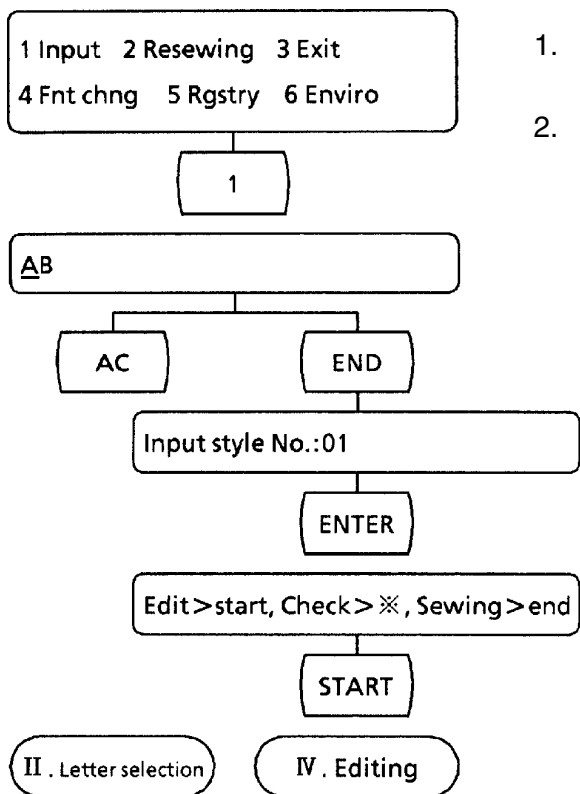

1. Press <1> to select [1. Input].
AB will be displayed.
2. To edit the monogram, press <AC> or <CLR> and select the new letters. See page 22.
To edit the same letters, "AB", press <END> and select the edit item. See page 50.

H0651

5-4-2. Resewing

The same monogram can be resewn after sewing is completed.

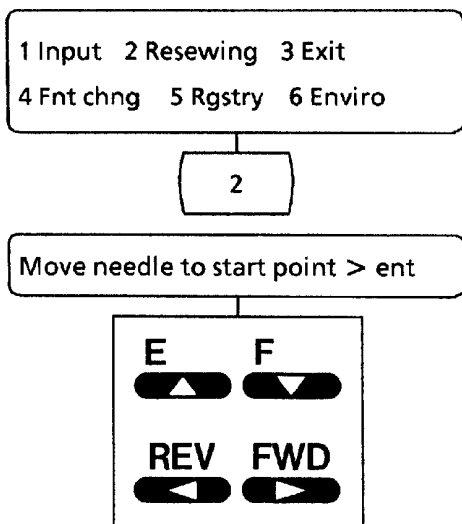

1. Press <2> to select [2. Resewing].
 2. To sew on the same piece of material, move the needle position using the jog keys, and set a new needle start position.
- * If the jog key is presses for too long and the sewing area is overrun will be alternately displayed. Move the needle back in the direction indicated by the displayed arrow to set the needle position.

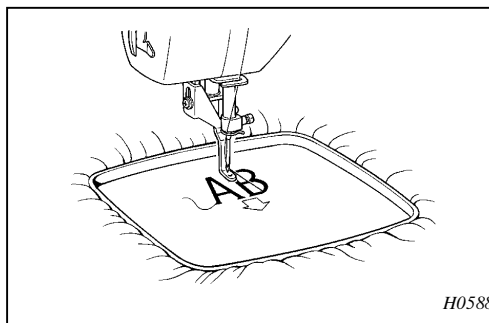

H0588

H0652

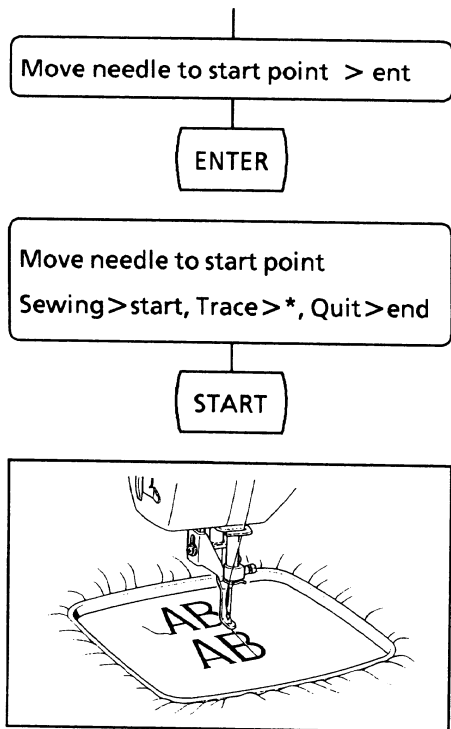

H0589

3. Press <ENTER>. The new needle start position is set.

4. Press <START> and select <Sewing>. AB will be sewn again.

5-4-3. Replacing the floppy disk

The font used to monogram letters can also be changed by changing the floppy disk. Optional design pattern disks can also be used.

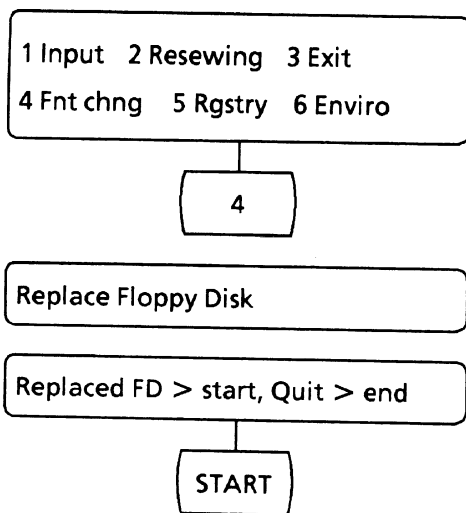

H0653

1. Press <4> and select [4. Fnt chng]. These messages will be alternately displayed.

2. Insert the optional font disk or optional design pattern, disk, and press <START>. [AB] will be displayed and the font will be changed.

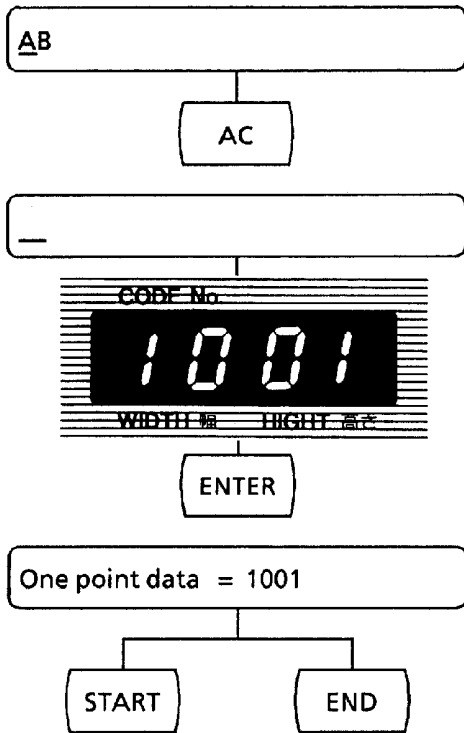

- * If the floppy disk is not changed, press <END>. [AB] will be displayed.
- * To use the design pattern disks, press <AC> on the operation panel to clear the indication, and enter the desired signal character data code number using number keys.

3. Input the signal character data code. Press <1>, <0>, <0>, and <1> in this order.
4. Press <ENTER>
5. Press <START> to start sewing; press <END> to enter the editing mode.

H0590

5-4-4. Environment settings

After sewing is completed, the sewing machine can then automatically move to the next operation (which can be selected from menu selection, input, or resewing).

When sewing is completed or if sewing is canceled while it is in progress, "1 Input 2 Resewing 3 Exit 4 Fnt chng 5 Rgstry 6 Enviro" will be displayed. If you select "6 Enviro" at this point, "0 Select 1 Input 2 Re-sew" will be displayed. "0 Select" continues according to the current specifications, "1 Input" causes the input screen to be displayed when sewing is completed or if sewing is canceled while it is progress, and "2 Resew" causes the resewing screen to be displayed when sewing is completed or if sewing is canceled while it is in progress. If "1" or "2" is selected from the "6 Enviro" screen, you can press the <ENTER> key immediately before sewing to display the menu selection screen.

6. Editing

6-1. Editing letters and numbers

[Example 1] Edit the letters AB.

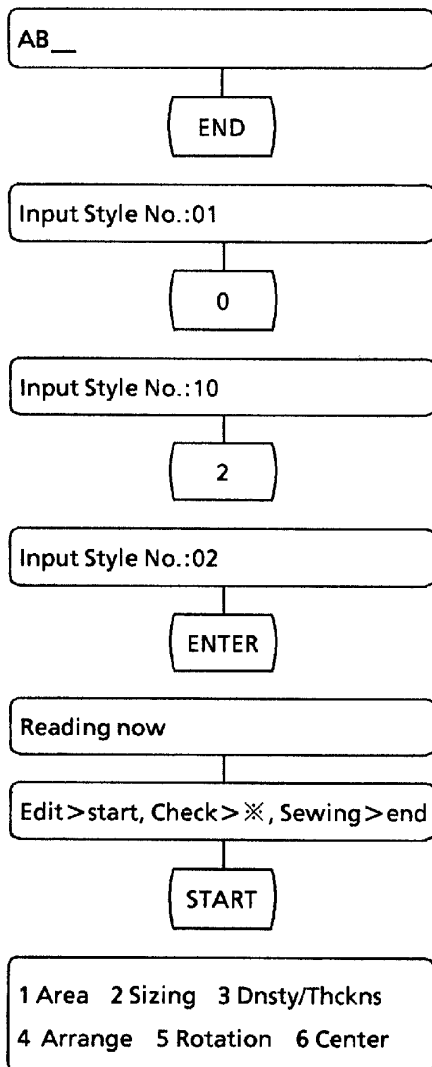

H0654

1. Press <END>.

2. Select the font.

Examples

- 01 Gothic
- 02 Cursive
- 03 Floral
- 04 Italic

3. Press <ENTER>.

When the font change is cancelled, press <END>. The messages, [Not Changes] and [Press end key] will be displayed alternately.

Press <END> again.

Shown while the floppy disk drive indicator is on.

Shown when the floppy disk drive indicator goes out.

4. Press <START> and select [Edit].

The edit menu will be alternately displayed.

Select a function: 1 Area, 2 Sizing, 3 Dnsty/Thckns, 4 Arrange, 5 Rotation, 6 Center

* To confirm the edit contents, press <✖>. See page 73.

* To sew, press <END>. See page 42.

6-2. Edit item selection

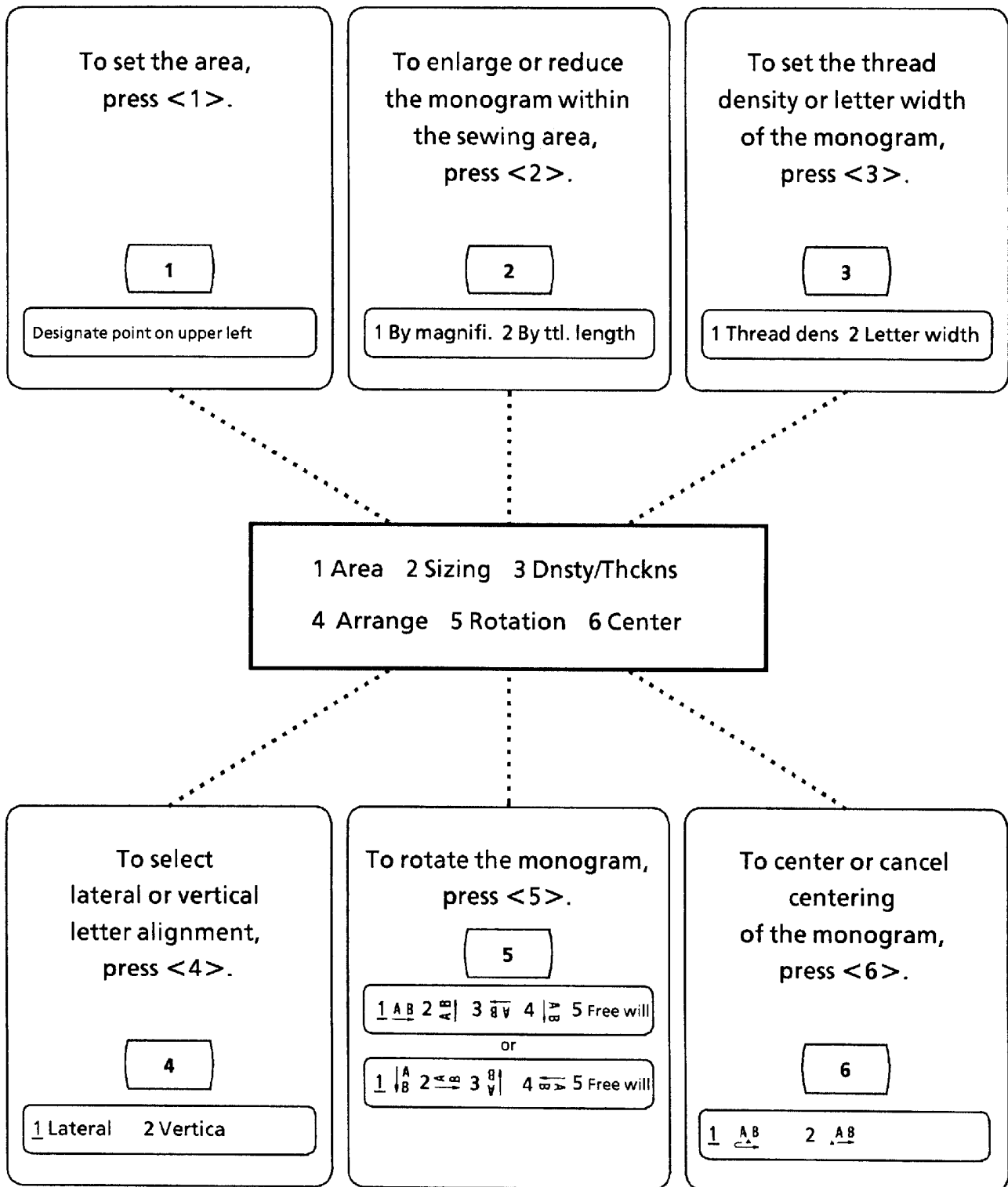

H0655

6-3. Setting the sewing area

Sewing area can be set by either of the following:

1. Inputting hoop number
2. Specifying sewing area corners (left upper and right bottom corners)
3. At the sewing start, the frame number will be displayed on the operation panel. Before pressing the <START> key, check this number to make sure that the frame number matches the actual embroidery frame being used.

6-3-1. Setting sewing area for hoop number 02

1 Area 2 Sizing 3 Dnsty/Thckns
4 Arrange 5 Rotation 6 Center

1

1 Hoop No 2 Set size

1

Hoop No = 0 1

0

2

ENTER

Attention moving

1 Area 2 Sizing 3 Dnsty/Thckns
4 Arrange 5 Rotation 6 Center

H0656

Input characters, and press the <END> and <START> keys. The editing menu will appear on the display.

1. Press the <1> key to set the sewing area.

2. Press the <1> key to select hoop number.

(NOTE) If you press the <2> key, refer to the BAS-47 instruction manual.

The current set hoop number will appear.

3. Input hoop number (02), and press the <ENTER> key. The hoop number should be input with two digits.

The hoop will move to the center of the area, beeping four times as it does.

(NOTE) When moving, the hoop may hit the presser foot or a screw.

It is recommended that the hoop is attached after moving to the center of the area.

4. Sewing area for hoop number 02 is set.

(NOTE) When <X> key is pressed with this display, area dimensions will appear.

(NOTE) The hoop number will appear on the display when setting the sewing start point. (When setting sewing area by specifying corners, "00" will appear.)

6-3-2. Setting sewing area for hoop number

Number	Hoop type	Hoop shape	Area dimensions (mm)	Remarks
01	HA	Rectangle	120 × 100 (length y width)	
02	D	Oval	66 × 32 (length × width)	
03	E	Oval	36 × 64 (length × width)	
04	A	Circle	112 (Diameter)	Option
05	B	Circle	80 (Diameter)	Option
06	C	Circle	34 (Diameter)	Option
07	F	Oval	36 × 64 (length × width)	Option
08	3 x 6	Oval	112 × 52 (length × width)	Option
09	G	Rectangle	66 × 32 (length × width)	Option
10	For thick material	Rectangle	120 × 100 (length × width)	Option

(NOTE) The effective width for hoop no. 04 is 100 mm. The effective length for hoop no. 08 is 120 mm.

Embroidery hoop number

Standard hoops

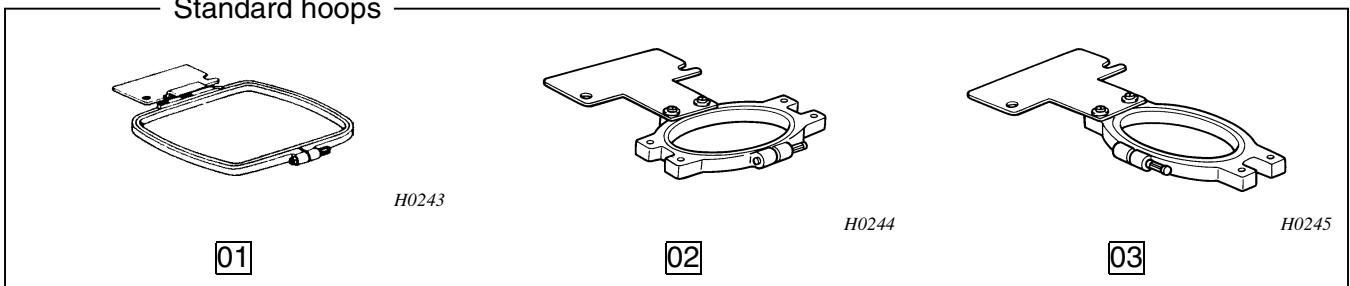

Optional hoops

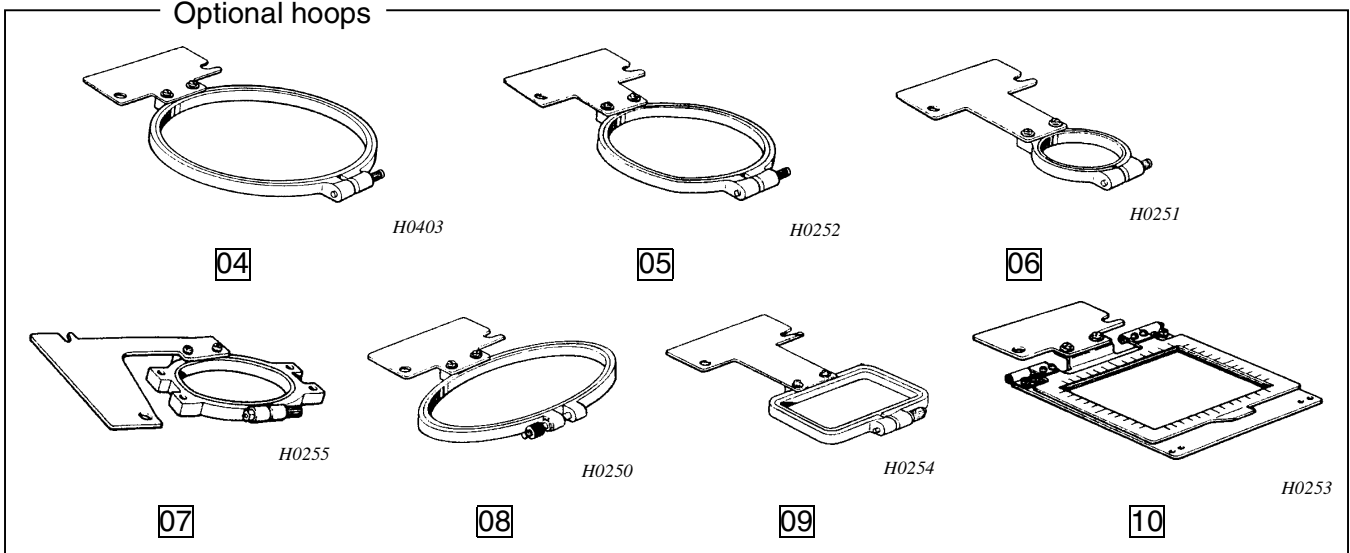

6-3-3. Setting the monogram area

This is used to set the monogram area within the embroidery hoop. Maximum sewing areas for the hoops are shown in the figures below. The monogram area is determined by setting the upper left corner and the bottom right corner.

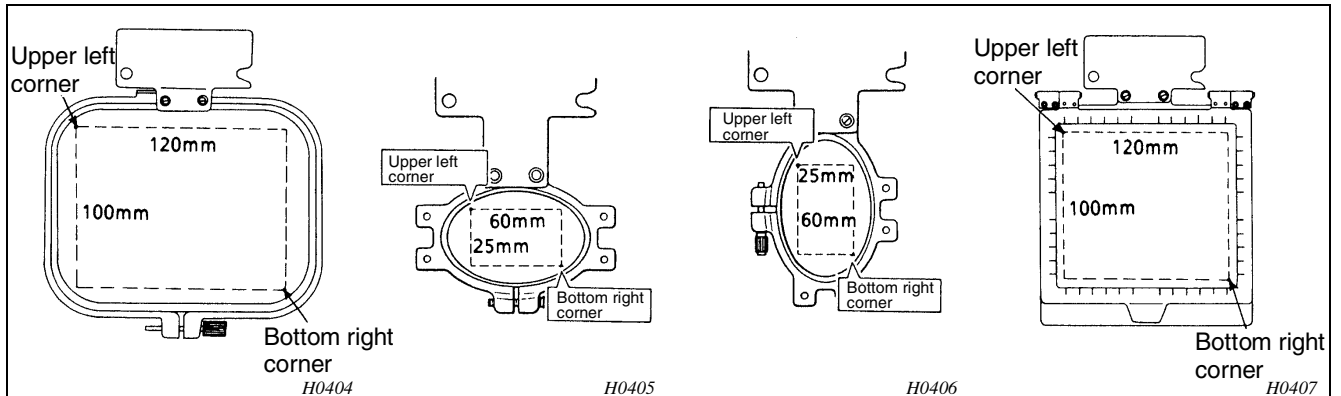

1 Area 2 Sizing 3 Dnsty/Thckns
4 Arrange 5 Rotation 6 Center

1

1 Hoop No 2 Set size

2

Designate point on upper left

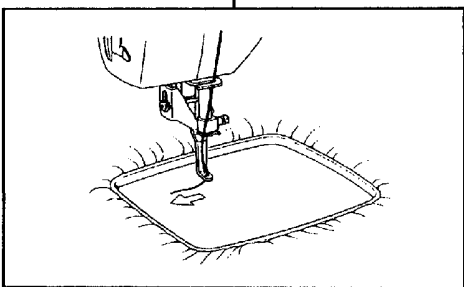
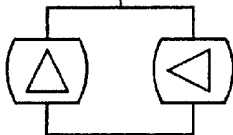

Designate point on upper left

See next page.

H0657

*1. Set the area with the embroidery hoop installed. The area must be contained within the hoop.

*2. The size and position of the monogram letters are determined by the size of the area.

1. Press <1> to select [1. Area].

2. Press the <2> key to select set size.

3. Use jog keys <△> and <◀> to move the needle position towards the top left of the embroidery hoop to determine the upper left corner inside the hoop.

(NOTE) [Turn pulley] will be displayed if the jog keys are pressed while the needle is down.

(NOTE) [Designate point on upper] will be displayed until the corner is set. The position of the needle is the upper left corner.

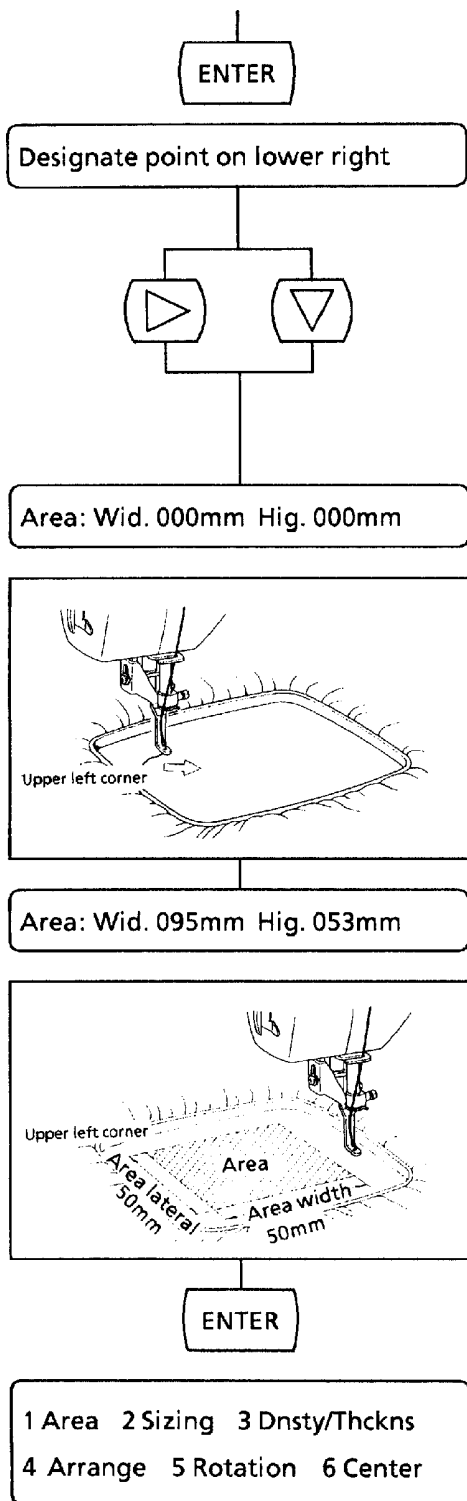

H0658

4. Press <ENTER>. The upper left corner is set. Displayed after the alarm sounds twice.
5. Press jog keys \triangleleft and ∇ to move the needle position towards the bottom right of the embroidery hoop to determine the bottom right corner inside the hoop.
 - * [Turn pulley] will be displayed if the jog keys are pressed while the needle is down.

* Width and height will be indicated by 3 digit numbers.

The distance of the needle position from the upper left corner along the X (width) and Y (lateral) axes will be displayed while the embroidery hoop is moving. The position of the needle is the bottom right corner.

6. Press <ENTER>. The bottom right corner is set. The edit menu will be alternately displayed.
 - (NOTE) Press <END> to cancel and exit area specification before the setting is completed. [Not Changed] and [Press end key] will be displayed. Press <END> again.

(NOTE) The largest possible area is 100 mm long by 120 mm wide.

(NOTE) Setting a sewing area larger than the embroidery hoop will cause the needle to strike the frame during sewing. If the area is larger than the embroidery hoop, be sure to set the needle start position and reduction ratio to keep the monogram within the hoop.

6-4. Enlarging or reducing

The monogram can be enlarged or reduced within the set area.

Enlargement and reduction settings can be made in four ways; [Altogether] and [Individual] for the ratio, and [Auto] or [Designate dimension] for the length and width.

In the case that characters are enlarged resulting in a stitch length more than 12.7 mm, the needle point is placed at the middle of a stitch in order to changes stitching. Refer to Tatami stitching, page 79.

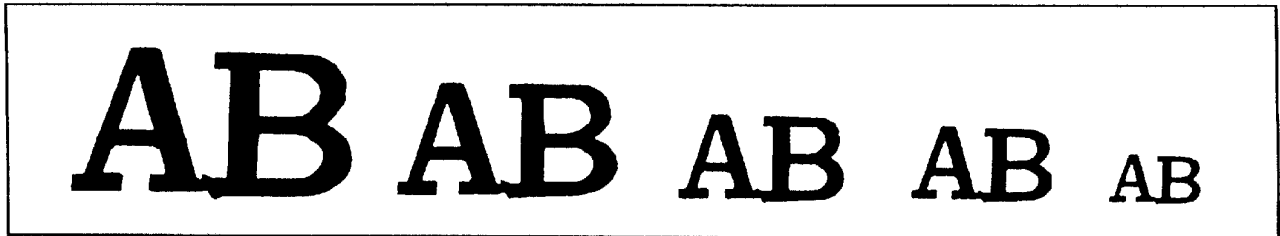

H0591

6-4-1. Setting the size ratio altogether

1 Area 2 Sizing 3 Dnsty/Thckns
4 Arrange 5 Rotation 6 Center

2

1 By magnifi. 2 By ttl. length

1

1 Altogether 2 Individual

1

1 Altogether 2 Individual



The enlargement and reduction ratio can be set in 0.1 unit increments. Changing the size ratio for one character automatically changes the sewing size ratio for the other characters, too.

1. Press <2> to select [2. Sizing].

2. Press <1> to select [1. By magnifi].

3. Press <1> to select [1. Altogether].

The LED indicator displaying the character width ratio 1.0 will blink.

(MEMO) The display will show [1.0 1.0] in the default settings mode, and the width indicator will blink. If a different ratio has already been set, that ratio will be displayed.

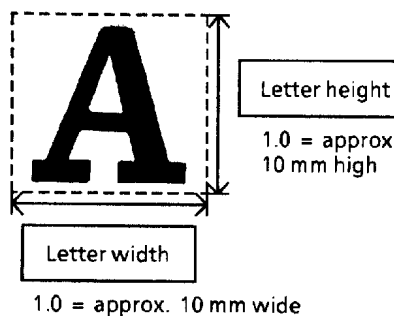

H0592

H0659

Width and height ratios can be varied from 0.1 - 9.9 times.

To change the size ratio for AB Altogether to width 1.5, height, 1.1.

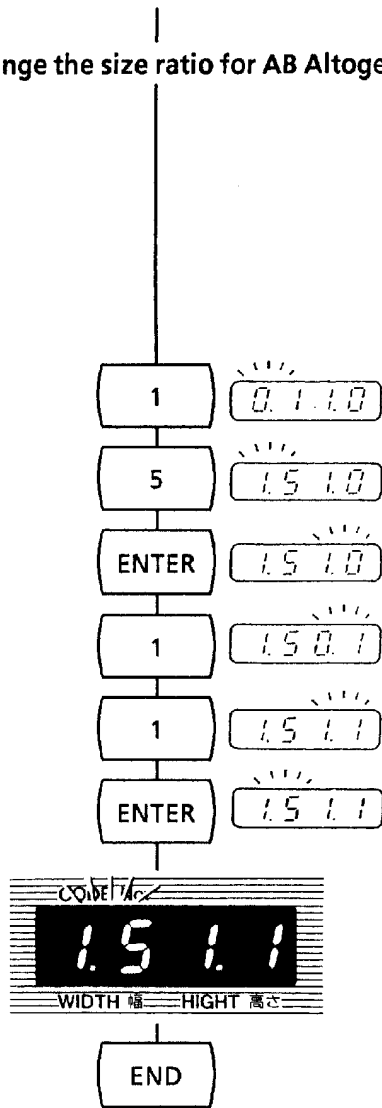

4. Press <1> and <5>.

The width ratio 1.5 will blink.
5. Press <ENTER>. The width ratio is entered. The height ratio 1.0 will now blink.
6. Press <1> and <1>.

The height ratio 1.1 will blink.
7. Press <ENTER>.

The height ratio is entered. The height ratio 1.5 will now blink. In the above example, the letters AB will now be sewn with a width 1.5 and height 1.1 times the standard size.
8. Press <END>.

The setting for the monogram AB is now completed. The edit menu will be alternately displayed.

1 Area 2 Sizing 3 Dnsty/Thckns
4 Arrange 5 Rotation 6 Center

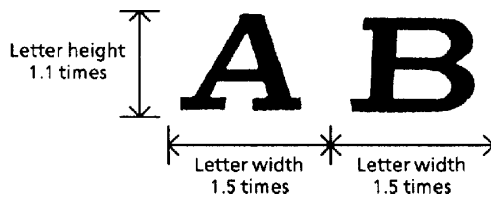

H0660



H0593

To confirm the edit contents, press <✕>. See page 73.
To sew, press <END>. See page 42.

Letter width and height can be changed to alter the shape of the letters in the monogram.

Ratio	Width < height	Width = height	Width > height
Modified letter	 (Long, narrow) H0594	 (Standard) H0595	 (Flat) H0596

(NOTE) Different letters may be of differing sizes even though the same size ratio is specified.

(NOTE) Sewing is not possible if the size ratio makes the letters larger than the specified area.

6-4-2. Setting the size ratio individual (1)

1 Area 2 Sizing 3 Dnsty/Thckns
4 Arrange 5 Rotation 6 Center

2

1 By magnifi. 2 By ttl. length

1

1 Altogether 2 Individual

2

AB



Set individual size ratios for the two letters AB.

A width ratio 1.5, height ratio 1.0
B width ratio 1.2, height ratio 0.9

1 0.1 1.0

5 1.5 1.0

ENTER 1.5 1.0

ENTER 1.5 1.0

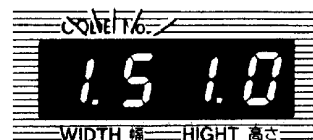

The enlargement and reduction ratio can be set in 0.1 unit increments, and for each letter individually.

1. Press <2> to select [2. Sizing].

2. Press <1> to select [1. By magnifi].

3. Press <2> to select [2. Individual].

The cursor will appear under the first letter, A, and the LED indicator will blink displaying the letter width ratio: 1.0.

(NOTE) The display will show [1.0 1.0] in the default settings mode, and the width indicator will blink. If a different ratio has already been set, that ratio will be displayed.

4. Press <1> and <5>.

The width ratio 1.5 for the letter A will blink.

5. Press <ENTER>.

The width ratio is entered. The height ratio 1.0 will now blink.

6. Press <ENTER>.

The height ratio 1.0 for the letter A is now set. The width ratio 1.5 will now blink.

* If the ratio shown by the indicator does not need changing, simply press <ENTER>.

A width ratio of 1.5 and height ratio of 1.0 have now been set for the letter A.

7. Press the jog key <◇>.

H0661

AB

The cursor will move under the B, and the width ratio 1.0 will blink.

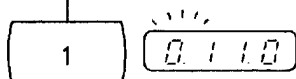

8. Press <1> and <2>.



The width ratio 1.2 for the letter B will blink.

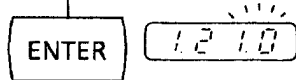

9. Press <ENTER>. The width ratio is entered. The height ratio 1.0 will now blink.

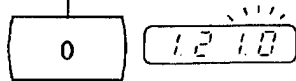

10. Press <0> and <9>.

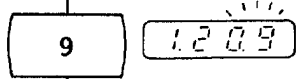

The height ratio 0.9 will blink.

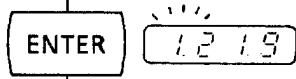

11. Press <ENTER>. The height ratio 0.9 for the letter B is now set. A width ratio of 1.2 and height ratio of 0.9 have now been set for the letter B. The size ratio settings for the monogram AB are now completed.

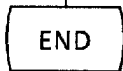

12. Press <END>. The size ratio settings for the monogram AB are now completed. The edit menu will be alternately displayed.

1 Area 2 Sizing 3 Dnsty/Thckns
4 Arrange 5 Rotation 6 Center

H0662

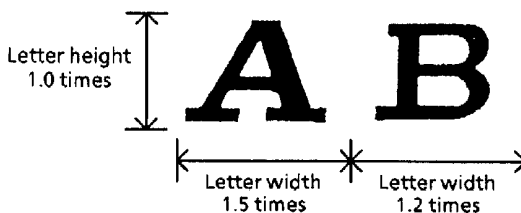

H0597

To confirm the edit contents, press <✳>. See page 73.
To sew, press <END>. See page 42.

(NOTE) After selecting individual, use the <⏪> and <⏩>, jog keys to select the letter. The current size ratio will be shown in the LED.

(NOTE) Sewing is not possible if the size ratio makes the letters larger than the specified area.

6-4-2. Setting the size ratio individual (2)

Inserting and deleting letter data

Size ratios are not applied to single specific letter, but to a position on the display, specifically, to certain display coordinates.

Because of this, changing the size ratio, sewing, and then adding or deleting letters may cause letter sizes to change as illustrated below.

[Ex.1]

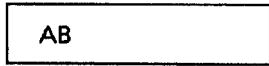

[1st letter]

[2nd letter]

A

B

H0599

H0600

Letter width	Letter height	Letter width	Letter height
0.6	1.0	2.0	1.5
[Ratio for 1st letter]		[Ratio for 2nd letter]	

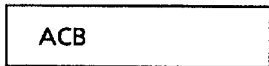
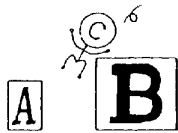

If the letter C is inserted between A and B, the size ratios will change as follows.

[1st letter]

[2nd letter]

[3rd letter]

A

C

B

H0599

H0602

H0600

Letter width	Letter height	Letter width	Letter height	Letter width	Letter height
0.6	1.0	2.0	1.5	1.0	1.0
[Ratio for 1st letter]		[Ratio for 2nd letter]		[Ratio for 3rd letter]	



As illustrated above, when letters are moved, letter size is determined by the size ratio assigned to the letter position (coordinates).

[Ex.2]



[1st letter]

[2nd letter]

[3rd letter]

A

C

B

H0599

H0602

H0600

Letter width Letter height

Letter width Letter height

Letter width Letter height

0.6 1.0

2.0 1.5

1.0 1.0

[Ratio for 1st letter]

[Ratio for 2nd letter]

[Ratio for 3rd letter]

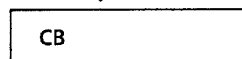

If the letter A is deleted, the size ratios change as follows.

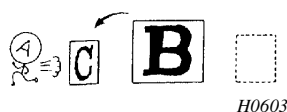

H0603

[1st letter]

[2nd letter]

C

B

H0602

H0600

Letter width Letter height

Letter width Letter height

0.6 1.0

2.0 1.5

[Ratio for 1st letter]

[Ratio for 2nd letter]

As illustrated above, when letters are moved, letter size is determined by the size ratio assigned the letter position (coordinates).

[Ex.3]

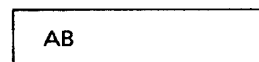

[1st letter]

[2nd letter]

A

B

H0599

H0600

Letter width Letter height

Letter width Letter height

0.6 1.0

2.0 1.5

[Ratio for 1st letter]

[Ratio for 2nd letter]

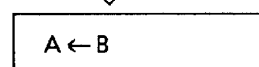
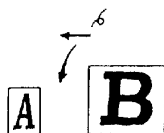

When the left arrow (←) code is inserted to bring the letters closer together, the ratios change as follows.

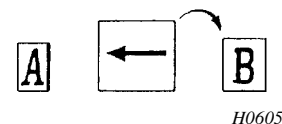

H0605

[1st letter]

[2nd letter]

[3rd letter]

A

←

B

H0599

H0607

H0600

Letter width Letter height

Letter width Letter height

Letter width Letter height

0.6 1.0

2.0 1.5

1.0 1.0

[Ratio for 1st letter]

[Ratio for 2nd letter]

[Ratio for 3rd letter]

Note that the spacing provided by an arrow insertion is 1 mm only when the size ratio for the insertion point coordinate is the default ratio [1.0 1.0]. If, as in example 3 above, the arrow is inserted at a point for which the size ratio is 2.0 the second letter, B, will be shifted 2 mm to the left.

6-4-3. Automatic calculation

Use automatic calculation for the monogram AB.

1 Area 2 Sizing 3 Dnsty/Thckns
4 Arrange 5 Rotation 6 Center

2

1 By magnifi. 2 By ttl. length

2

1 Auto 2 Designate dimension

1

1 Area 2 Sizing 3 Dnsty/Thckns
4 Arrange 5 Rotation 6 Center

H0663

Letter size can be automatically calculated and sewn to fit the area.

1. Press <2> to select [2. Sizing].

2. Press <2> to select [2. By ttl. length].

3. Press <1> to select [1. Auto].

The size ratio will be automatically calculated and set.
The edit menus will be alternately displayed.

- To confirm the edit contents, press <✳>. See page 73.

- To sew, press <END>. See page 42.

The size of the monogram will be determined by the area size.

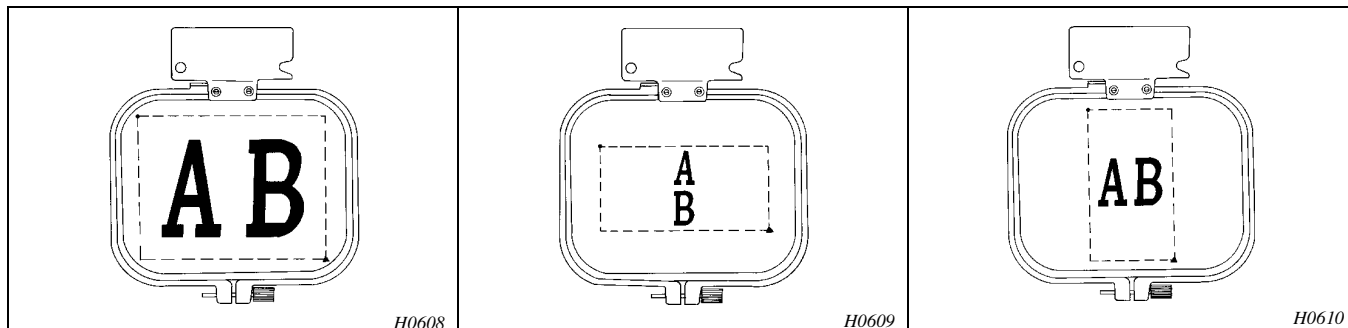

* Monogram letter size will be set to the largest ratio at which both the length and width can be sewn within the area.

* Check the automatically calculated size.
Monogram size determined by the automatic calculation mode can be checked. See page 73.

6-4-4. Designate dimensions

Specify the dimensions for the monogram

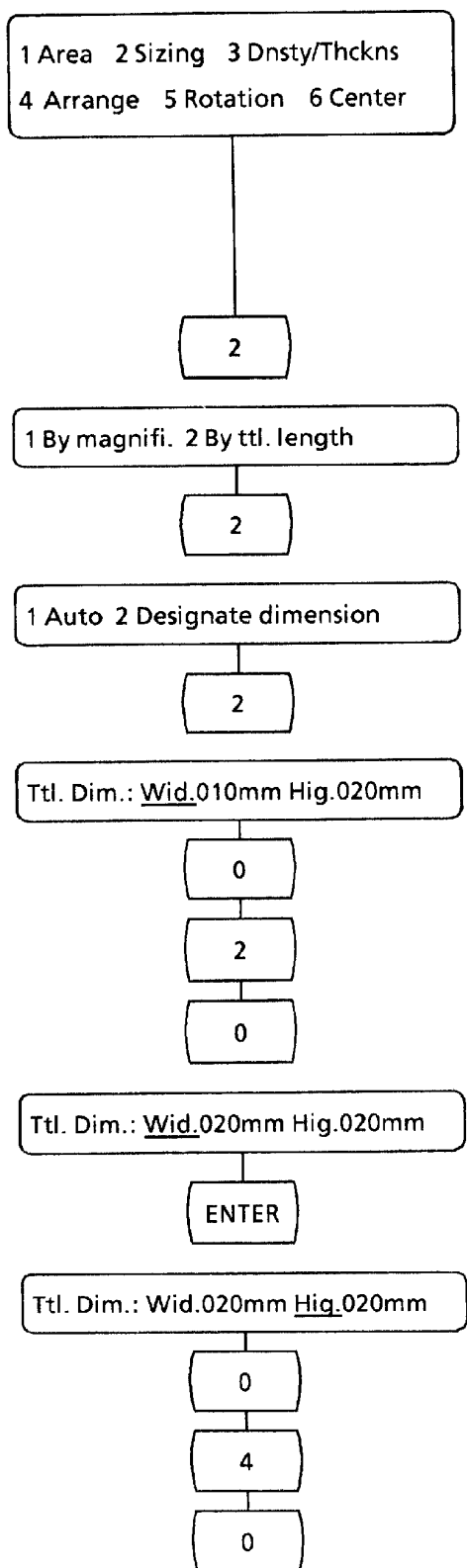

H0664

Letters can be enlarged or reduced in 1 mm increments, and the total length (length, width) can be specified for sewing.

(NOTE) If the total length equals or exceeds the sewing area, the following will occur.

- 1) The "Short of area" message will be displayed.
- 2) Proper needle starting point location will not be possible by pressing the jog keys \triangleleft \triangleright \triangleleft \triangleright while the "Move needle to start point >ent" and the "Area over" messages are displayed alternately. Reset the sewing area so that it is larger than it is larger than the total length.

1. Press <2> to select [2. Sizing].
2. Press <2> to select [2. By ttl. length].
3. Press <2> to select [2. Designate dimension].
The cursor will be positioned under Wid.
- * The total length of the currently displayed characters will be displayed as three digits. If the font is changed or other changes are made after sewing, the displayed value may differ from the length of the previously sewn characters.
- Ex) Set the total dimensions to Lat. 20 mm and Wid. 40 mm (area size: Lat. 50 mm and Wid. 50 mm)
4. Press <0> <2> <0>.
 - *1 Dimensions must be a three digit number.
 - *2 The total dimensions of the monogram must be within the specified area.
[Wid. 020 mm] will be displayed.
5. Press <ENTER>.
The total length is entered, and the cursor will move under Wid.
6. Press <0> <4> <0>.
 - *1 Dimensions must be a three digit number.
 - *2 The total dimensions of the monogram must be within the specified area.
[Lat. 040 mm] will be displayed.

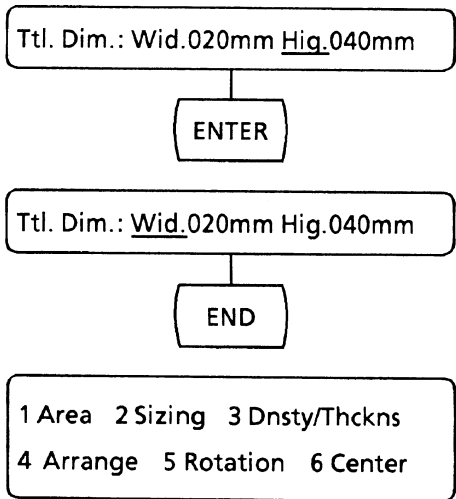

H0665

7. Press <ENTER>.

The total width is entered, and the cursor will move under Hig. again.

8. Press <END>.

The total dimensions for the monogram AB are now set. The edit menus will be alternately displayed.

* [A ↑ B]

When (after the magnification of each letter has, by dimension designation, become A (H. 1.0, W. 1.0) ↑ (H. 5.0) B (H. 1.0, W. 1.0) by individual designation) the overall size is increased two times, becoming A (H. 2.0, W. 2.0) ↑

[(H. 10.)] B (H. 2.0, W. 2.0), the space code magnification will exceed 9.9 even though the letter data only became twice as great, and sewing cannot be done.

* Ttl. Length must fit in sewing area. The same size will be deemed short of area.

6-5. Thread density and letter width

6-5-1. Thread density

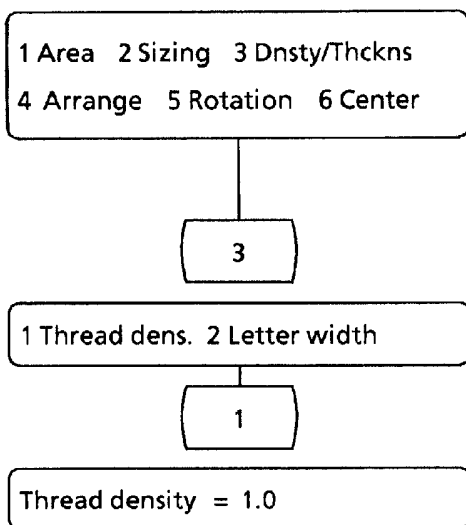

H0666

The ratio of the thread density and letter width of the monogram can be changed. This is particularly convenient when sewing small letters.

The thread density ratio of monogram letters can be changed from a minimum of 0.1 to a maximum 2.0 times.

1. Press <3> to select [3. Dnsty/Thckns].
2. Press <1> to select to select [1. Thread dens].
The current thread density ratio will be displayed.
(MEMO) The default setting is 1.0.
(MEMO) If the thread density ratio has already been set, that ratio will be displayed.

Ex) Change the thread density to 1.2 times.

<Default>
 Heavier 2.0 ← 1.0 → 0.1 Coarser

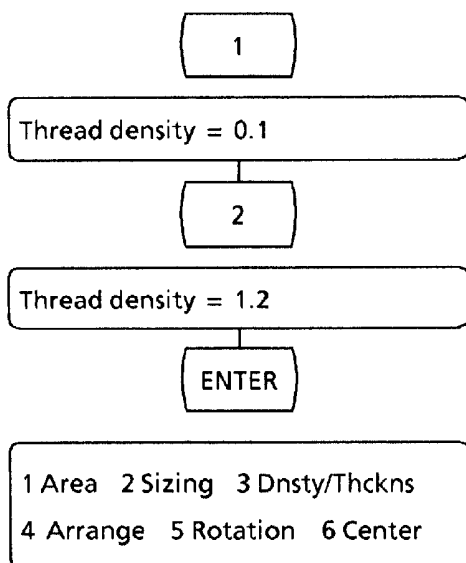

H0668

3. Press <1>.
The 0 will be carried and an 1 will appear in the first place.
4. Press <2>.
The 1 will be carried and a 2 will appear in the first place.
5. Press <ENTER>.
The thread density ratio of 1.2 is set.
When the thread density setting is cancelled, press <END>.
The messages [Not Changed] and [Press end key] will be displayed alternately.
Press <END> again.
The edit menus will be alternately displayed.
To confirm the edited contents, press <X>. See page 73.
To sew, press <END>. See page 42.

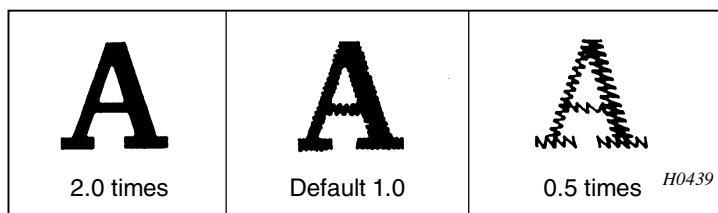

6-5-2. Letter width

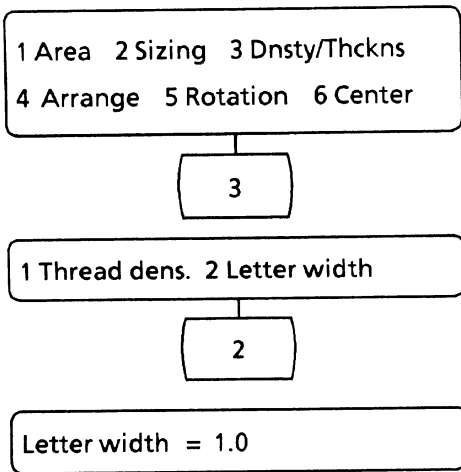

H0669

The width ratio of monogram letters can be changed from a minimum of 0.6 to a maximum 2.0 times.

1. Press <3> to select [3. Dnsty/Thckns].
2. Press <2> to select to select [2. Letter width].
The current letter width will be displayed..
 - * The default setting is 1.0.
 - * If the letter width has already been set, that setting will be displayed.

Ex) Change the letter width to 1.5 times.

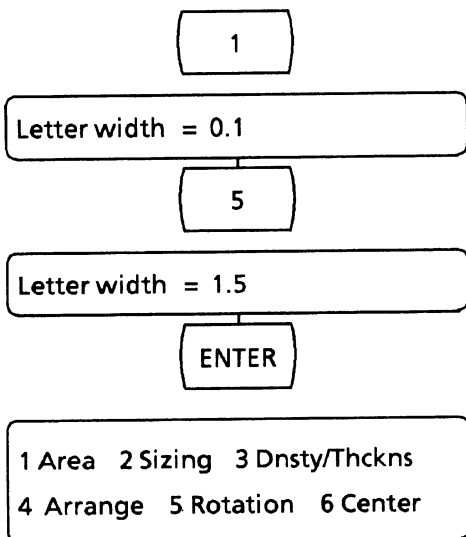
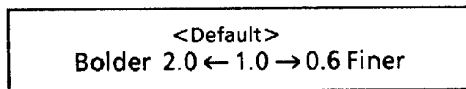

H0671

3. Press <1>.
The right 0 will be changed to 1.
4. Press <5>.
The 1 will be moved to the left of the decimal point and the 5 will appear on the right.
5. Press <ENTER>.
The letter width of 1.5 times is set.
When the thread density setting is cancelled, press <END>.
The messages [Not Changed] and [Press end key] will be displayed alternately.
Press <END> again.
The edit menu will be alternately displayed.
To confirm the edited contents, press <X>. See page 73.
To sew, press <END>. See page 42.

* In the case that letter width is decreased to a size smaller than the original width using alphabets style code No.1, the first and end stitches become longer as below.



H0611

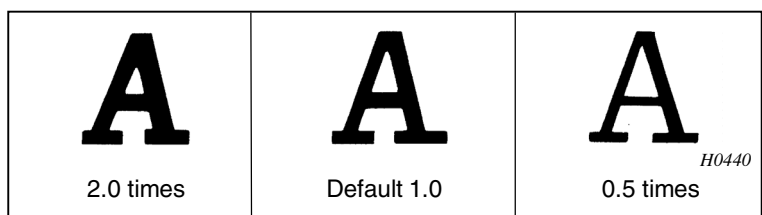

H0440

6-6. Arrange

Letters can be aligned laterally and vertically.

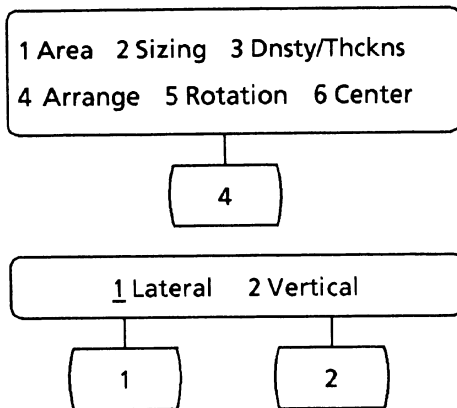

H0672

1. Press <4> to select [4. Arrange].
The cursor will be positioned under the current alignment setting.
* The default setting is [1. Lateral].
2. Press <1> to select [Lateral] alignment.
Press <2> to select [Vertical] alignment.

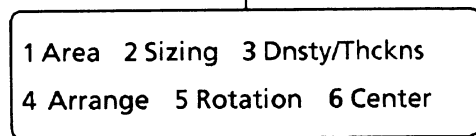
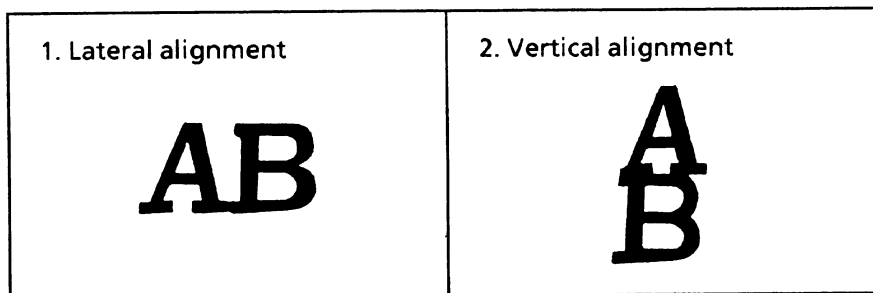

H0612

The edit menus will be alternately displayed.
To confirm the edit contents, press <X>. See page 73.
To sew, press <END>. See page 42.

- * See page 72 for letter positions when lateral alignment is changed to vertical alignment.
- * In the case to sew small letters such as "f", "g", "j", "p", "q", "y", "z" vertically aligned, those letters overlap with the next letters.

6-7. Rotation

The monogram can be additionally rotated in 90° steps for either lateral or vertical alignment.

6-7-1. If lateral alignment is selected

1 Area 2 Sizing 3 Dnsty/Thckns
4 Arrange 5 Rotation 6 Center

5

Lateral 1 AB 2 \overleftarrow{AB} 3 \overrightarrow{AB} 4 \overupdownarrow{AB} 5 Free will

1 2 3 4 5

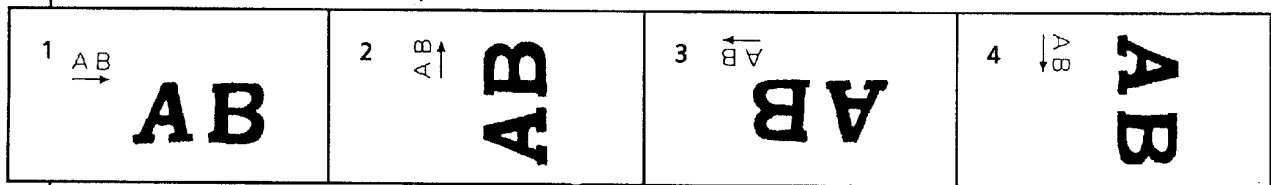

1 Angl 2 2pts designation

1

Angle = 000 > enter anti = clockws

ENTER

1 Area 2 Sizing 3 Dnsty/Thckns
4 Arrange 5 Rotation 6 Center

1. Press <5> to select [5. Rotation].
The cursor will be positioned under the current setting.

* The default setting is [1. AB].

2. Press the number 1, 2, 3, or 4 to select the desired lateral rotation.

The edit menus will be alternately displayed.

- To sew, press <END>. See page 42.

- To confirm the edit contents, press <✳>. See page 73.

H0614

6-7-2. If Vertical alignment is selected

1 Area 2 Sizing 3 Dnsty/Thckns
4 Arrange 5 Rotation 6 Center

5

Vertical 1 \downarrow $\begin{matrix} A \\ B \end{matrix}$ 2 \leftarrow $\begin{matrix} A \\ B \end{matrix}$ 3 \uparrow $\begin{matrix} B \\ A \end{matrix}$ 4 \rightarrow $\begin{matrix} A \\ B \end{matrix}$ 5 Free will

1 2 3 4 5

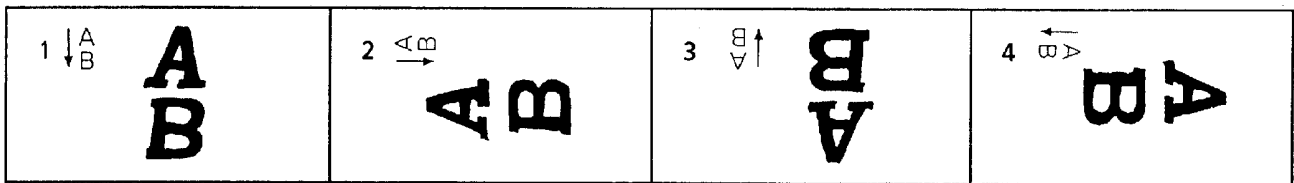

1 Area 2 Sizing 3 Dnsty/Thckns
4 Arrange 5 Rotation 6 Center

1. Press <5> to select [5. Rotation].

The cursor will be positioned under the current setting.

* The default setting is [1. AB].

2. Press the number <1>, <2>, <3>, or <4> to select the desired vertical rotation.

The edit menus will be alternately displayed.

- To sew, press <END>. See page 42.

- To confirm the edit contents, press <✕>. See page 73.

H0615

6-8. Centering

Centering of the monogram can be set or cancelled.

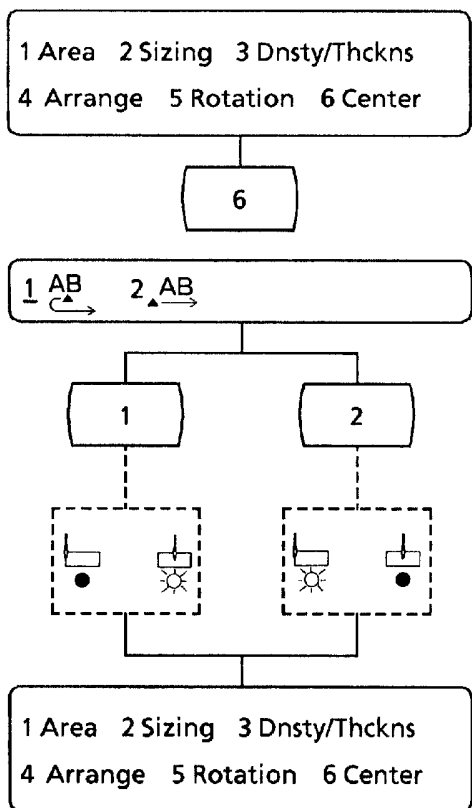

H0673

1. Press <6> to select [6. Center].

The cursor will be positioned under the current setting.
(MEMO) The default setting is [1. AB].

2. To set centering, press <1>.
To cancel centering, press <2>.

The edit menu will be alternately displayed.

(MEMO) To sew, press <END>. See page 42.
To confirm the edit contents, press <✳>. See page 73.

6-8-1. With centering

- Line is not finished using the return code.

Sewing starts regarding the current needle position as the center.

E.g. There are five letters on a line.



This is the needle position when <START> is pressed.

H0452

- Lines are finished using the return code.

Sewing starts regarding the current needle position as the center position of the first line. The needle position is the center of the first line at the start of sewing. On and after the second line, lines are aligned with the center of each line of text.

E.g.

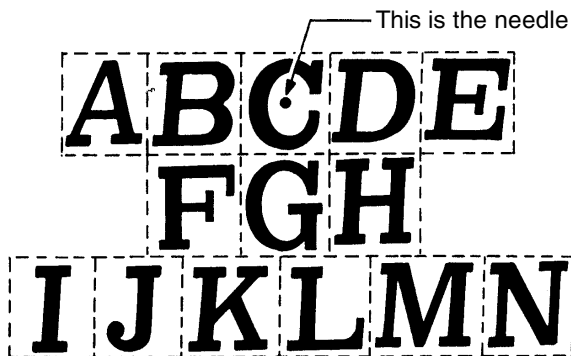

This is the needle position when <START> is pressed.

H0453

6-8-2. Without centering

- Line is not finished using the return code.

Sewing starts regarding the current needle position as the left end of the text.

E.g.



This is the needle position when <START> is pressed.

H0454

- Lines are finished using the return code.

Sewing starts regarding the current needle position as the left end of the text on the first line, the needle position being considered as being at the left end of the first line at the start of sewing. On and after the second line, the left end of the lines are aligned with the left end of the first line of text.

E.g.

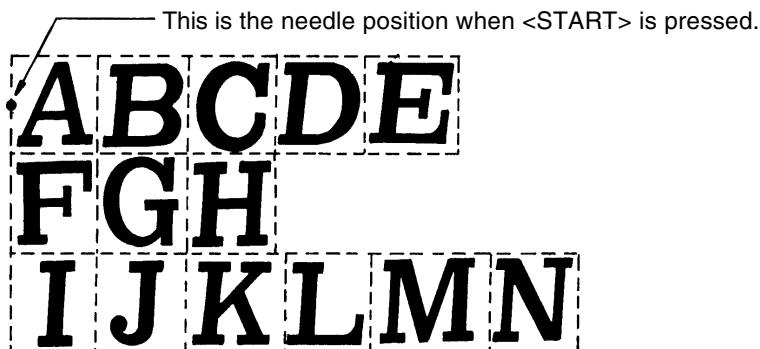













This is the needle position when <START> is pressed.

H0455













6-8-3. Setting the needle start position and sewing position

Refer to this section when setting the needle start position.

Set the monogram AB for lateral positioning.

Rotation Centering	 H0616-1	 H0616-2	 H0616-3	 H0616-4
Centering selected	 H0616-5	 H0616-6	 H0616-7	 H0616-8
Centering cancelled	 H0617-1	 H0617-2	 H0617-3	 H0617-4

Set the monogram AB for vertical positioning.

Rotation Centering	 H0618-1	 H0618-2	 H0618-3	 H0618-4
Centering selected	 H0618-5	 H0618-6	 H0618-7	 H0618-8
Centering cancelled	 H0619-1	 H0619-2	 H0619-3	 H0619-4

* The sewing position can be checked with the test mode.

6-9. Editing item confirmation

The settings of any edit item can be checked.

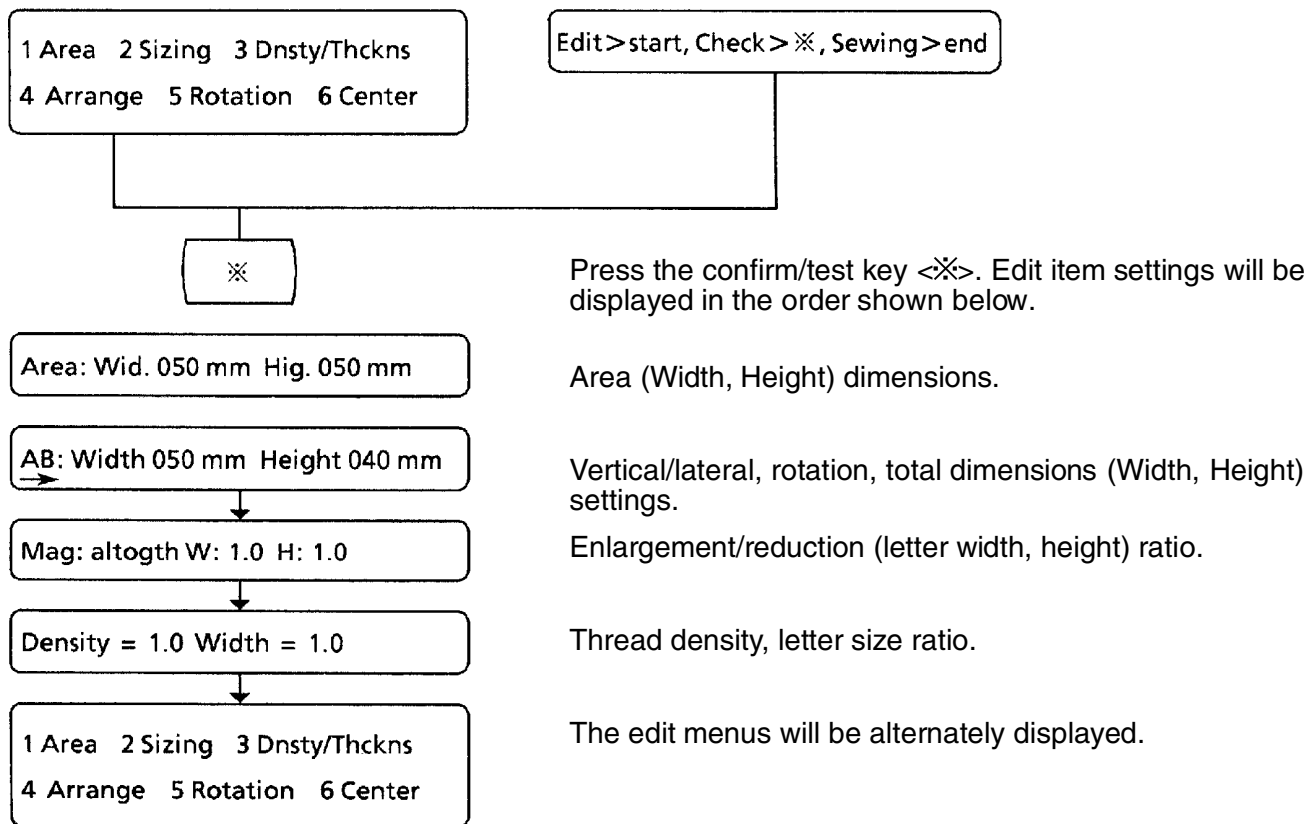

H0674

- *1 If the total length (Width, Height) is greater than the dimensions of the area (Width, Height), [Short of area] will be displayed. Re-edit.
- *2 Edit item contents can be confirmed as frequently as desired by simply pressing the confirm/test key <※>.

Default (standard) settings

Edit items can also be reset to the default (standard) settings.

1 Area 2 Sizing 3 Dnsty/Thckns
4 Arrange 5 Rotation 6 Center

AC

H0675

Press <AC>.

All edit items will be reset to the default (standard) settings.

Default values	
Area:	Wid. 120 mm Hig. 100 mm
AB:	Width <input type="text"/> <input type="text"/> <input type="text"/> mm Height <input type="text"/> <input type="text"/> <input type="text"/> mm
Ratio:	Width 1.0 Height 1.0
Thread density = 1.0 Letter width = 1.0	

H0676

1 Area 2 Sizing 3 Dnsty/Thckns
4 Arrange 5 Rotation 6 Center

H0677

In addition, the centering mode is selected and the centering indicator  will light.

6-10. Setting the sewing speed

Sewing speed can be changed before sewing or while sewing is suspended. It can be selected from three levels; slow (500 rpm), middle (800 rpm), and fast (1000 rpm).

Move needle to start point
Sewing > start, Trace > *, Quit > end

[Before sewing]

Re-start > start, Clear > clr

[When sewing is suspended]

1

Press <1>.

Speed: (fast < middle > slow) Fast

The current sewing speed setting will be displayed.

This is the current sewing speed setting.

- * When the jog key \triangleleft is used
Sewing speed which is one level slower than the current one will be displayed.
Sewing speed change order

→ Fast → Middle → Slow →

H0680

- * When the jog key \triangleright is used
Sewing speed which is one level faster than the current one will be displayed.
Sewing speed change order

→ Fast → Middle → Slow →

H0681

Speed: (fast < middle > slow) Middle

Speed: (fast < middle > slow) Fast

END

(NOTE) When <CLR> is pressed, fast sewing speed will be displayed.
Press <END>. The displayed speed will be set.

Move needle to start point
Sewing > start, Trace > *, Quit > end

[Before sewing]

[When sewing is suspended]

H0679

Stitch length and sewing speed

	Stitch length (mm)					
	0.1 - 2.9	3.0 - 3.4	3.5 - 4.4	4.5 - 5.5	5.6 - 7.3	7.4 - 12.7
Fast	1000 rpm	650 rpm	500 rpm	400 rpm	300 rpm	150 rpm
Middle	800 rpm	500 rpm	400 rpm	300 rpm	150 rpm	150 rpm
Slow	500 rpm	400 rpm	300 rpm	150 rpm	150 rpm	150 rpm

6-11. Stop position change function

When a needle is at its down position, "Turn the pulley" is displayed and the buzzer continues to sound intermittently.

Turn the pulley to raise the needle, press the <END> key to cancel the error. If such error occurs frequently, do the following setting.

(NOTE) There is no need to do the following setting every time the power is turn off, because the setting is in memory even if the power is turned off.

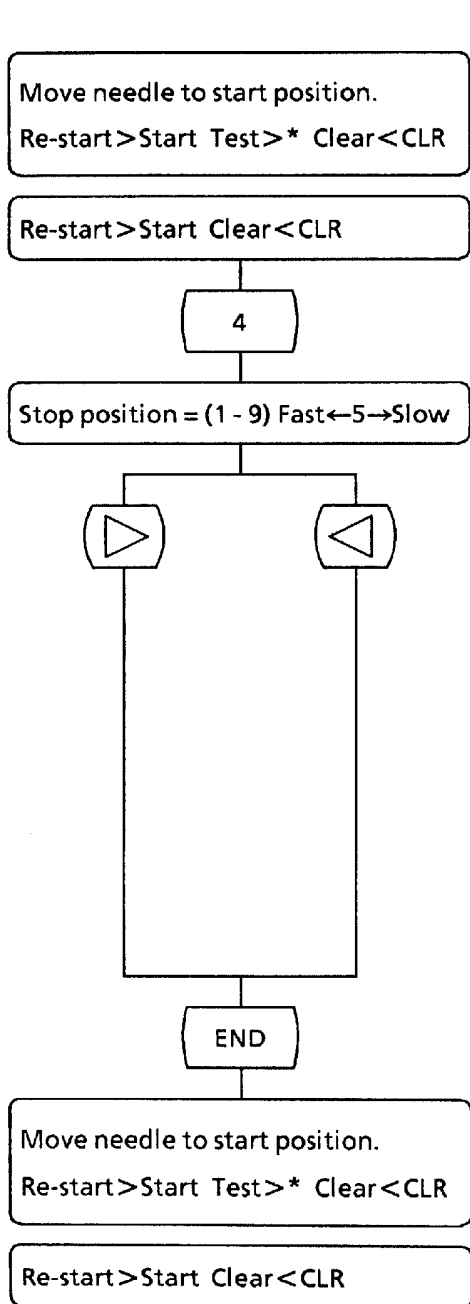

H0682

Changing machine stop position

[Before sewing start]

[When sewing is suspended]

1. Press the <4> key.

Current stop position is displayed.

2. Setting position can be set at 9 levels by the jog keys.

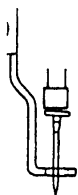

H0456

- If needle end stickes out from presser foot, set the timing to "Fast"

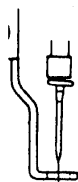

H0457

- If needle end is above presser foot, set the timing to "Slow"

3. Press the <END> key to return to the first screen.

7. Optional Parts

7-1. Sub table

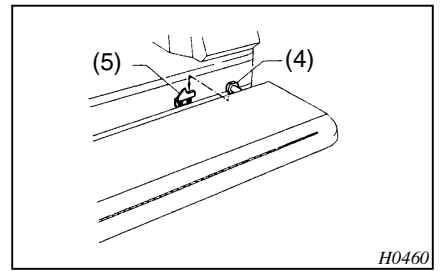
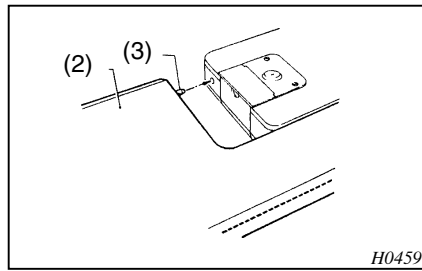
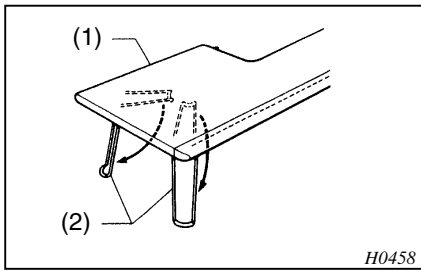

1. Extend the legs (2) of the sub table (1).
2. Insert the guide pin (3) into the hole in the machine by slightly lifting up the sub table (1).
3. Lower the guide pin (5) onto guide pin support F (4). Remove the sub table in the reverse order.

7-2. Spring

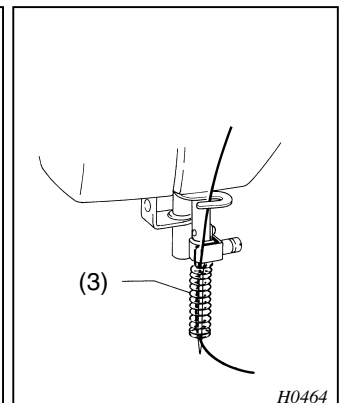
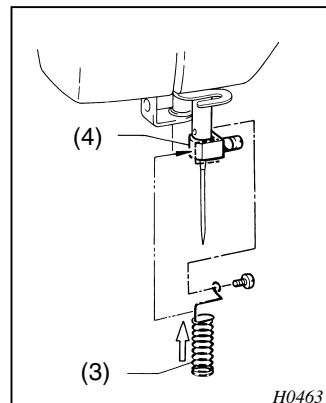
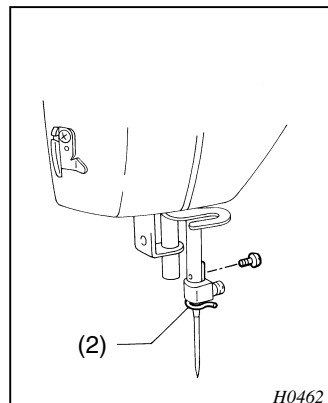
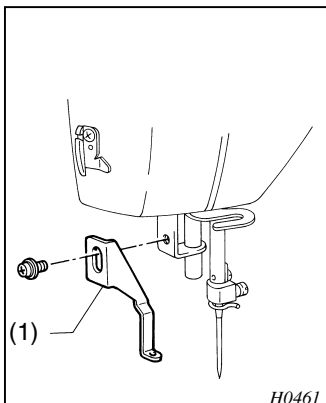

1. Turn the pulley to set the needle bar to its lowest position. Remove the screw, and the presser foot (1).
2. Remove the screw of the needle bar thread guide (2), and then remove the needle bar thread guide (2).
3. Pass the needle through the spring (3). Hook the spring onto the needle clamp (4), and secure it using the screw.
4. Pass the thread through the spring as shown in the figure above.

(NOTE) Bend the spring. Adjust the spring position so that it is centered around the needle.

8. Trouble Shooting

If there seems to be a malfunction, first try to diagnose the problem referring to the table below. If the problem persists and cannot be resolved, turn the power switch off and contact your dealer.

	Problem	What to check
Check once more.	1. Power switch is on but display does not come on.	Is the display contrast properly adjusted?
	2. A floppy disk is in the drive but the indicator does not light.	Is the disk damaged?
	3. Thread breakage.	<ul style="list-style-type: none"> - Is the machine properly threaded? - Is the thread tension too high? - Is the rotary hook assembly clogged? - Is there thread on the bobbin? - Is the needle bent? - Is there a gouge in or rough edge on the needle plate, rotary hook, or bobbin case that might cut the thread? - Is the thread wound around the thread breakage detector? - Is the pre-tension too weak? - Is the thread breakage detector operating? (Refer to "11. Thread breakage detector".)
	4. Needle strikes the embroidery hoop.	<ul style="list-style-type: none"> - Is the area specification properly set? - Is the embroidery hoop too small?
	5. Bobbin thread cannot be wound.	Is the rubber roller worn?
	6. Needle breaks.	<ul style="list-style-type: none"> - Are the needle direction and height properly adjusted? - Is the needle bent? - Is the needle tip blunt?
	7. Monogram letters are not properly sewn. (Characters are too narrow.)	<ul style="list-style-type: none"> - Is the material edge catching on the edge of the machine? (Are the embroidery hoop and other parts operating correctly?) - Is the carriage wire loose? Refer to "Wire adjustment method" on page 81 of the instruction manual.

If the backup memory contents are erased (e.g., in the case the machine is left unused for an extended period), items 8-2 and 8-3 below may occur.

	Problem	What to check
Check once more.	<p>8-1. Jog keys are pressed but the needle position does not change.</p> <p>8-2. During area specification, the needle position does not change even though the jog keys are pressed (hoop does not move).</p> <p>8-3. During setting of the needle start position, the needle position does not change even though a jog key (s) is pressed (hoop does not move).</p>	<p>The jog keys can only be used under the following conditions to adjust the needle position. Pressing the jog keys at any other time has no effect.</p> <ul style="list-style-type: none"> - During editing in the [1. Area] selection when: [Designate point on upper left] is displayed, or [Designate point on lower left] is displayed. - When the needle start point is set before sewing starts <p>When the message</p> <div style="border: 1px solid black; padding: 5px; display: inline-block; margin: 10px 0;"> <p>Move needle to start point > ent Sewing>start, Trace>*, Quit>end</p> </div> <p>are displayed alternately.</p> <p>When the message [OUTSIDE SEWING AREA] is displayed.</p> <p>Turn the power switch off, press <START> and <CLR> simultaneously, and turn the power switch on again. (This clears the backup memory.)</p> <ul style="list-style-type: none"> - Press <END> and reset the area in the edit mode. - Turn the power switch off, press <START> and <CLR> simultaneously, and turn the power switch on again. (This clears the backup memory.)

9. Error Messages

Refer to the table below when an error message is displayed.

Message	Cause	Solution
Short of area	The total sewing length exceeds the area.	Press <END>, and either change the area, size ratio, or rotation, or re-enter the monogram letters.
Floppy Disk Error	The disk is damaged. Replace the disk.	Press any key. If the display does not go out, turn the power switch off and then on again. If the display still does not go out, contact your dealer.
Memory over-Letter	Memory capacity overflow.	Press <END>, and re-enter the letters or edit the monogram. (See p.46 to re-enter, p.46 to edit.)
Letter dimension over area	The entered value exceeds the range of 4 mm - 120 mm.	Press <START>, and re-enter the correct value. (See p.62 for dimension specification.)
Letter over area	Area specification is inappropriate.	Reset the area. (See p.50.)
Thread breakage	Stop motion assembly is loose.	Tighten the stop motion assembly.
	- Upper thread breakage.	Press <END>, thread the needle thread, reverse the needle several stitches, and press <START> to resew, or press <END> and cancel sewing.
	- Thread is not wound onto the thread breakage detector.	Wrap the needle thread around the thread breakage detector and press <START> to resew, or press <END> and cancel sewing.
Impossible detect point x	- Bobbin thread breakage or bobbin thread has run out.	Remove the bobbin, fill it, and reset.
	Damaged circuit board, disconnected cable, or short.	Contact your dealer.
Impossible detect point y	Pulse motor problem, disconnected cable, or short. Blown fuse.	
Over Load	Pulley is too tight. The needle thread is wound onto the pulley, making it hard to turn.	Remove the load or thread from around the pulley.
	Thread is wound around the rotary hook assembly.	Remove the thread.
	Motor problem. Blown fuse on the circuit board.	Contact your dealer. Bring back the bobbin presser.
	Enlargement/reduction ratio exceeds 0.1 - 9.9. Lower thread bobbin presser is not returned.	Press <END>. The previously entered value appears, and the machine is returned to the editing mode.
Data error-Letter	Error in the data.	Replace the floppy disk. Contact your dealer.
Not Changed	When a Tajima disk is indicated to be used but a different kind of disk is inserted.	Insert the Tajima disk, and press <END>.
Memory over	Data volume of the Tajima disk is too large.	Press <END>, and input another pattern.

10. X-Y Feed Adjustment

If the monogram letters appear to be too narrow, adjust the wire.

10-1. Removing the X-Y feed unit

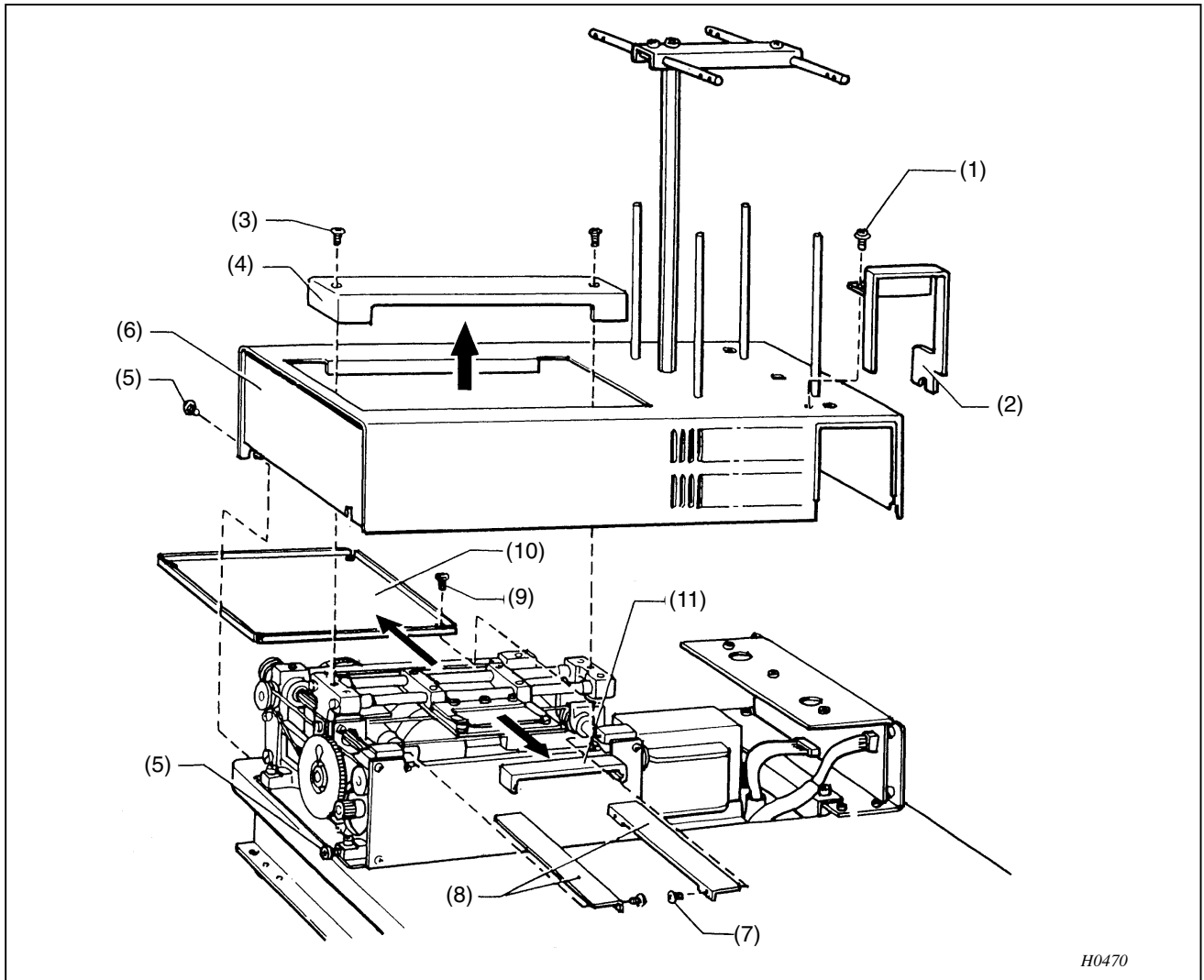

1. Remove the screw (1), and the harness cover (2).
2. Remove the two screws (3), and the slide cover (4).
3. Loosen the five screws (5), and remove the cover (6).
4. Remove the four screws (7), and the left and right covers US (8).
5. Remove the four screws (9), and cover U (10).
6. Remove the slide cover (11).

(NOTE) If adjusting the X mini wire, carry out steps 4, 5 and 6.

10-2. Adjusting the wire in the X direction

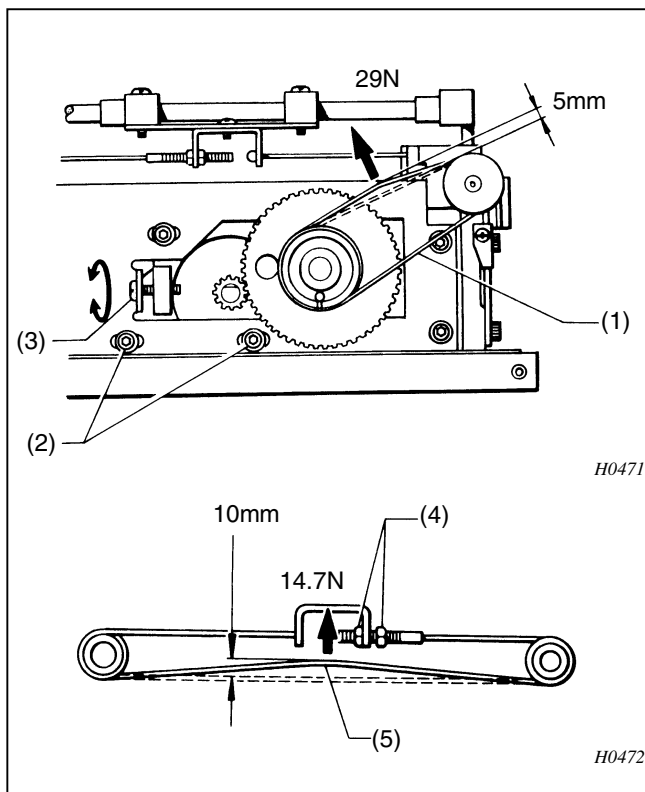

Loosen the three screws (2), and then turn the adjustment screw (3) to adjust so that there is about 5 mm of deflection in the X drive wire (1) when a load of 29 N is applied to the middle of the wire.

(MEMO) If adjustment is not possible by following step 1
Tighten the nut (4) (without twisting the X mini wire (5) to adjust so that there is about 10 mm of deflection in the X mini wire (5) when a load of 14.7 N is applied to the middle of the wire.

10-3. Adjusting the wire in the Y direction

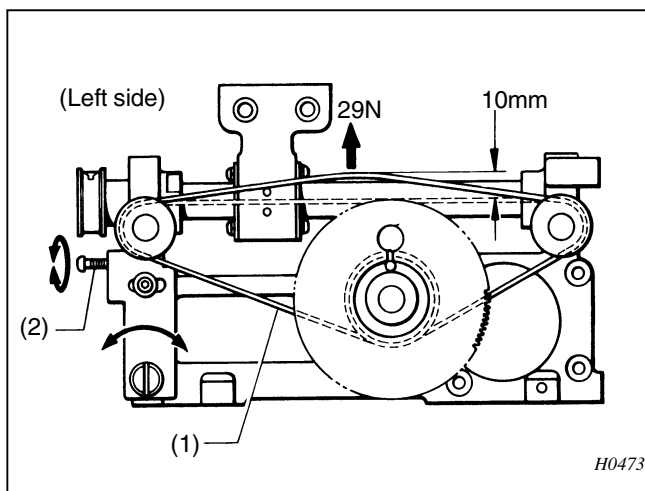

Turn the screw (2) to adjust so that there is about 10 mm of deflection in the Y mini wire (1) when a load of 29 N is applied to the middle of the wire.

(NOTE) Adjust the tension of the Y mini wire on the R (right) side in the same way as was done on the L (left) side.

11. Adjusting the upper thread breakage detector

11-1. Checking the upper thread breakage detector operation

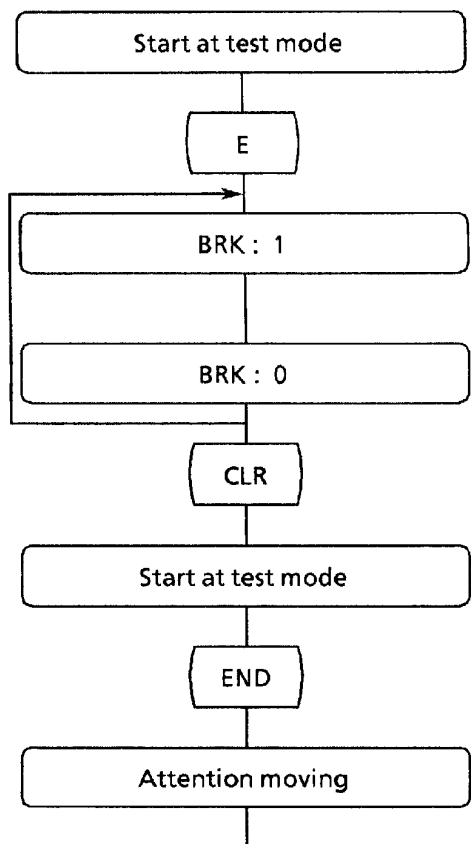

1. While pressing the <START> key and the <ENTER> key together, turn on the power.

2. Press the <E> alphabetic key.

If the display repeatedly changes between "0" and "1" when pulley A of the upper thread breakage detector is turned, operation is normal.

3. Press the <CLR> key.

4. Press the <END> key.

H0684

11-2. Cleaning the upper thread breakage detector

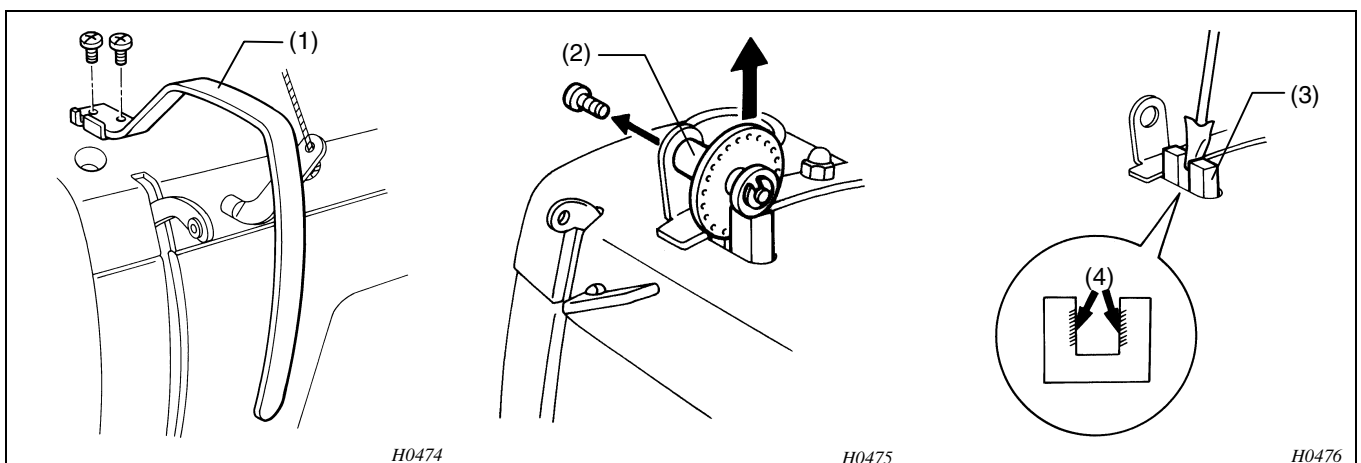

1. Remove the thread take-up cover (1) and the pulley shaft (2).
2. Clean the transmitter and receiver sections (4) of the upper thread breakage photosensor (3) by blowing them air or by wiping them with a clean cloth.
3. Attach the pulley shaft (2) and adjust as mentioned above. Fix the pulley shaft (2) by the fixing screw so that the display changes 1 -> 0 -> 1 -> 0.

12. Character Code List

English Alphabet

CHARACTER	Code	CHARACTER	Code
A	41	a	61
B	42	b	62
C	43	c	63
D	44	d	64
E	45	e	65
F	46	f	66
G	47	g	67
H	48	h	68
I	49	i	69
J	4A	j	6A
K	4B	k	6B
L	4C	l	6C
M	4D	m	6D
N	4E	n	6E
O	4F	o	6F
P	50	p	70
Q	51	q	71
R	52	r	72
S	53	s	73
T	54	t	74
U	55	u	75
V	56	v	76
W	57	w	77
X	58	x	78
Y	59	y	79
Z	5A	z	7A

European Type

CHARACTER	Code	CHARACTER	Code
Å	80	ú	9E
Ä	81	á	9F
Ü	82	•	A0
ß	83	ó	A1
Ç	84	Õ	A4
Ö	85	ã	A5
Ñ	86	õ	A6
Æ	87	í	A7
ø	88	ì	A9
â	89	ò	AA
à	8A		
à	8B		
ä	8C		
ä	8D		
ï	8E		
î	8F		
û	90		
ù	91		
ü	92		
ê	93		
è	94		
é	95		
ë	96		
ô	97		
ö	98		
ø	99		
ñ	9A		
ç	9B		
æ	9C		
Ø	9D		
Ã	A3		

SYMBOLS

CHARACTER	Code	CHARACTER	Code
·	2E		7F
:	3A	*	2A
?	3F	0	30
!	21	1	31
•	2D	2	32
/	2F	3	33
"	22	4	34
&	26	5	35
'	27	6	36
(28	7	37
)	29	8	38
~	7E	9	39

Underlines can also be used in the monogram

CHARACTER Code
Font code 02
A2

* Space codes cannot be used to place arrows in the monogram. These are used to adjust the space the between characters.

Space Code	CHARACTER	Code	CHARACTER	Code
↑	1C	→	1E	
↓	1D	←	1F	

13. Floppy Disk Input Contents List

NUMBER	INPUT CONTENTS	NUMBER	INPUT CONTENTS
FF-01		FF-21	
FF-02		FF-22	
FF-03		FF-23	
FF-04		FF-24	
FF-05		FF-25	
FF-06		FF-26	
FF-07		FF-27	
FF-08		FF-28	
FF-09		FF-29	
FF-10		FF-30	
FF-11		FF-31	
FF-12		FF-32	
FF-13		FF-33	
FF-14		FF-34	
FF-15		FF-35	
FF-16		FF-36	
FF-17		FF-37	
FF-18		FF-38	
FF-19		FF-39	
FF-20		FF-40	

brother[®]



INSTRUCTION MANUAL

BROTHER INDUSTRIES, LTD.

15-1, Naeshiro-cho, Mizuho-ku, Nagoya 467-8561, Japan. Phone: 81-52-824-2177

Printed in Japan

155-111
S93111-002
2001.08.F (1)