

PARTS BOOK
FOR
BROTHER LK3-B826

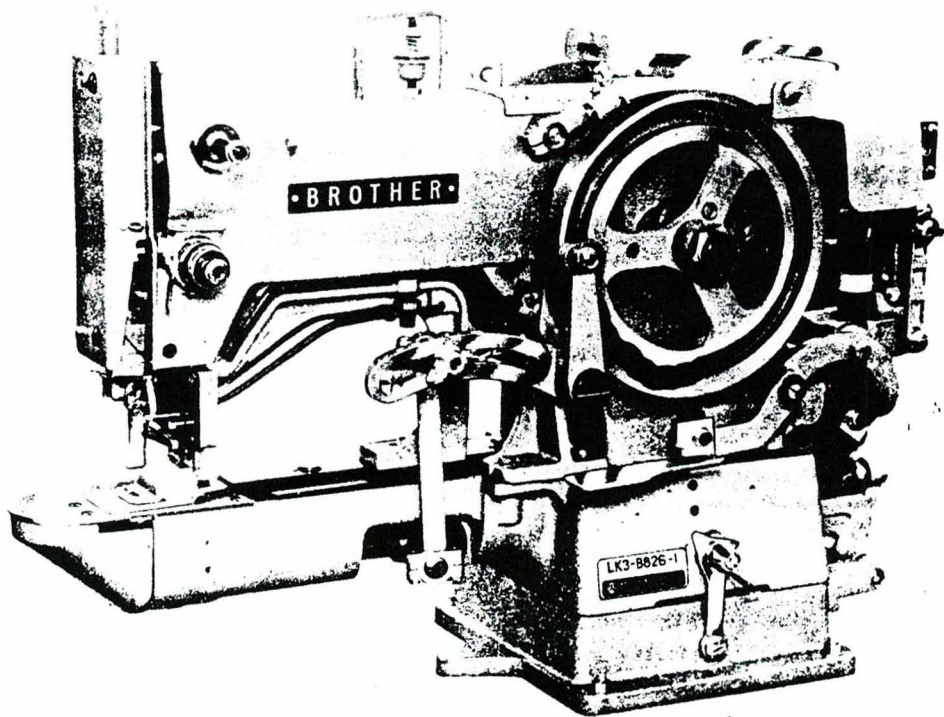

Washby



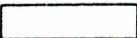

High Speed Bar Tack Machine

BROTHER INDUSTRIES, LTD.
NAGOYA, JAPAN

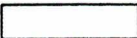

Notes for using this parts book

1. If the symbol  is found in the "Parts No." column or the "Assembly No." column, refer to the separate parts list on page 10.
2. The symbol  in the "Parts No." column indicates that the part is not available for supply. If, however, there is a number in the "Assembly No." column, the part can be ordered as an assembly. Please, therefore, order by using the Assembly No..
3. If the ※ symbol is found before the Part No., order this part together with its paired part.
4. This book was prepared based on information available in March, 1978.
5. Parts are subject to changes in design without prior notice.

Anmerkungen zum Gebrauch dieses Stücklistebuches

1. Dieses Zeichen  in der Spalte "Parts No. (Teilnummer)" oder "Assembly No. (Gerätesatznummer)" verweist auf die Gesonderte Stückliste auf Seite 10.
2. Dieses Zeichen  in der Spalte "Teilnummer" bedeutet, daß dieser Teil nicht lieferbar ist. Wenn jedoch in der Spalte "Gerätesatznummer" eine Nummer steht, kann dieser Teil als ein Geräteteilsatz bestellt werden. Bestellen Sie daher bitte mit dieser Gerätesatznummer.
3. Bei diesem Zeichen ※ vor der Teilnummer bestellen Sie bitte diesen Teil paarweise, zusammen mit seinem Gegenstück.
4. Dieses Buch basiert auf den Informationen vom März, 1978.
5. Modelländerungen sind vorbehalten.

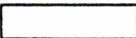
Notas para usar este Libro de Piezas

1. De haber un símbolo  junto al "Parts No. (Número de Pieza)" o en la columna del "Assembly No. (Número de Juego)", habrá que mirar la lista de piezas separada de la página 10.
2. El símbolo , que se encuentra en la columna del "Número de Pieza", quiere decir que no se dispone de dicha pieza sola. Cuando, empero, hay un número en la columna del "Numero de Juego"; se podrá ordenar la pieza con todo el juego. Por lo tanto, será mejor hacer el pedido recurriendo al número del juego respectivo.

3. Si, antes del número de una pieza, se encuentra el símbolo ✖, habrá que ordenar dicha pieza junto con la otra con la que va la misma.
4. Este libro ha sido compilado basándose en los datos de que se disponía en Marzo de 1978.
5. Las piezas quedan sujetas a cambios de diseño sin aviso previo.

Notes sur l'utilisation de ce manuel de pièces détachées

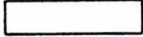
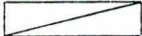
1. Si le symbole  se trouve dans la colonne "Parts No. (N° de pièce)" ou dans la colonne "Assembly No. (N° jeu de pces)", veuillez vous référer à la liste de pièces annexe page 10.
2. Le symbole  dans la colonne "N° de pièce" signifie que la pièce ne peut être fournie. Si, dans la colonne "N° jeu de pces", il y a un numéro de nomenclature, la pièce peut être commandée comme faisant partie d'un jeu de pièces. Donc, pour toute commande, veuillez spécifier le n° du jeu de pièces.
3. Si, devant le n° de pièce, il y a le symbole ✖, veuillez commander cette pièce avec sa pièce appariée.
4. Ce manuel a été fait d'après les renseignements valables au mois de Mars, 1978.
5. Les pièces peuvent être sujettes à des modifications sans préavis.

CONTENTS

A. Machine Body	1
B. Upper Shaft, Needle Bar Mechanism.....	2
C. Clutch Mechanism	3
D. Feed, Cam Mechanism	4
E. Feed Mechanism.....	5
F. Thread Trimmer	6
G. Presser Mechanism	7
H. Threading Mechanism	8
Z. Accessories.....	9
SEPARATE PARTS LIST.....	10
INDEX.....	11

A. Machine Body

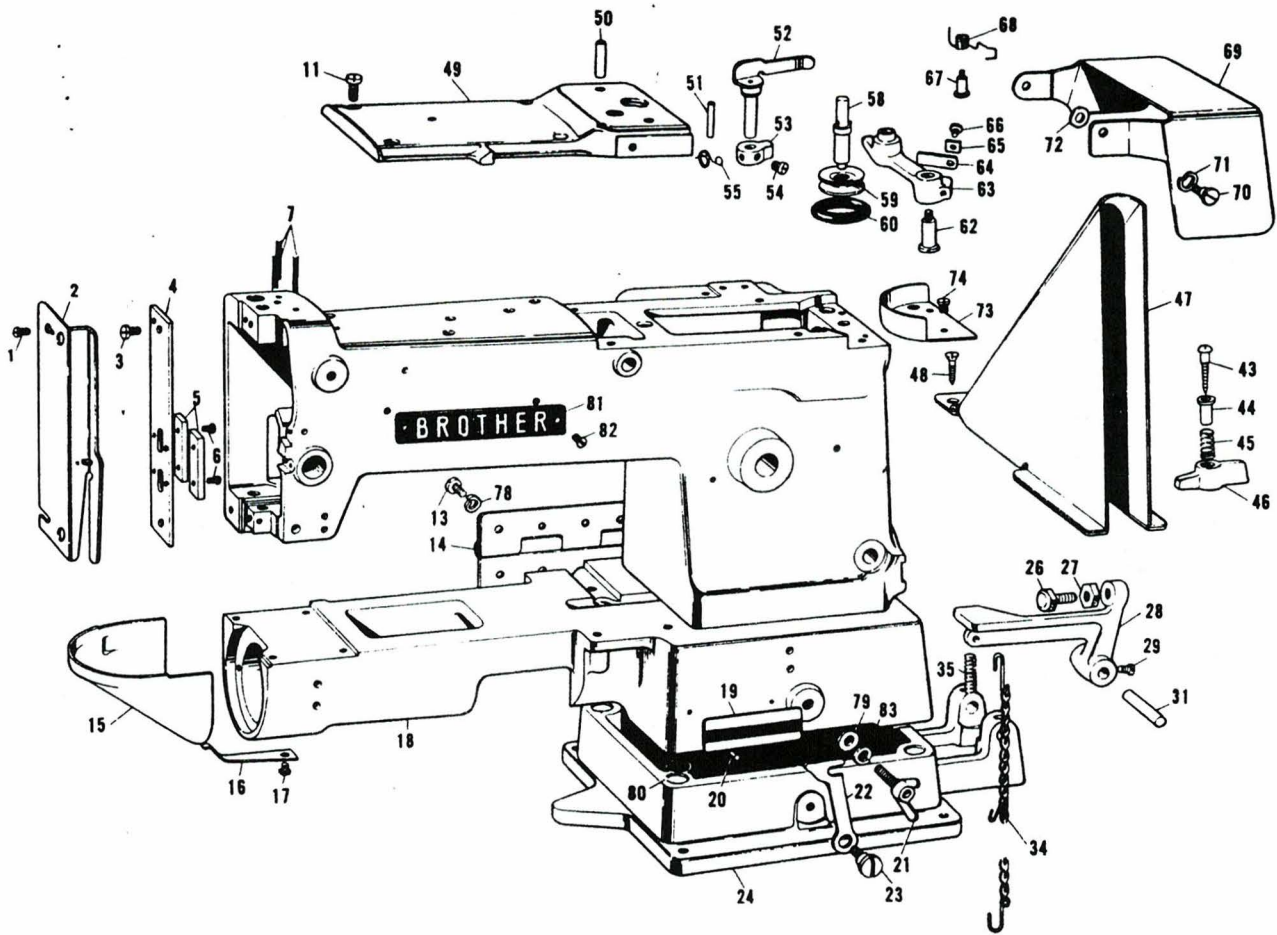

Ref. No.	Name of Parts	Q'ty	Parts No.	Assembly No.	Ref. No.	Name of Parts	Q'ty	Parts No.	Assembly No.	
A-1	Screw	2	009671-0-13		A-47	Belt Cover Assembly	1	118867-0-01		
A-2	Face Plate Assembly	1	116835-0-01		A-48	Screw	2	033351-3-03		
A-3	Screw	2	009780-8-12		A-49	Arm Cover	1			
A-4	Needle Bar Guide Plate	1	117310-0-01	Needle Bar Guide Assembly 117526-0-01	A-50	Spring Pin	1	047502-8-42	Arm Cover Assembly 118387-0-01	
A-5	Needle Bar Guide	2	117309-0-01		A-51	Pin	1	107331-0-01		
A-6	Screw	4	009680-8-12		A-52	Bobbin Presser	1	111948-0-01		
A-7	Wick 12 x 12	3	115383-0-01		A-53	Bobbin Winder Pawl	1	142566-0-01		
A-11	Screw	4	009761-2-13		A-54	Screw	1	104908-0-04		
A-13	Screw	8	009781-4-13		A-55	Stopper for Bobbin Presser	1	145275-0-01		
A-14	Bed Hinge Assembly	1	116824-0-01		A-58	Bobbin Winder Shaft	1			Bobbin Winder Assembly 142083-0-01
A-15	Shuttle Race Cover Assembly	1	115442-0-01		A-59	Bobbin Winder Wheel	2			
A-16	Spring	1	115446-0-01		A-63	Bobbin Winder Shaft Holding Bracket	1			
A-17	Screw	1	009680-7-13		A-60	Rubber Ring	1	120448-0-01		
A-18	Arm Bed Assembly	1		A-62	Stud Screw	1	104212-0-02			
A-19	Model Plate	1		A-64	Elastic Plate	1	149191-0-01			
A-20	Knock Pin	2		A-65	Washer	1	111943-0-01			
A-21	Wing Screw	1	115390-0-01	A-66	Set Screw	1	100080-0-01			
A-22	Bed Supporter Hook	1	115388-0-01	A-67	Stud Screw	1	103317-0-01			
A-23	Stud Screw	1	115389-0-01	A-68	Spring	1	118390-0-01			
A-24	Bed Base	1	115385-1-01	A-69	Pulley Cover	1	118392-0-01			
A-26	Bolt	1	115585-0-01	A-70	Screw	2	115559-0-01			
A-27	Nut	1	022840-3-03	A-71	Spring Washer	2	028060-2-42			
A-28	Starting Lever	1	115584-0-01	A-72	Washer	2	118236-0-00			
A-29	Screw	1	009761-0-12	A-73	Daster Plate	1	118386-0-01			
A-31	Starting Lever Shaft	1	115586-0-00	A-74	Screw	2	009670-5-12			
A-34	Starting Lever Connecting Chain (B)	1	106812-0-01	A-78	Washer	8	028770-2-43			
A-35	Starting Lever Spring	1	115587-0-01	A-79	Washer	1	025080-2-33			
A-43	Screw	2	031482-5-03	A-80	Rubber Cushion	4	141026-0-00			
A-44	Collar	2	115541-0-01	A-81	Name Plate	1				
A-45	Spring	2	115382-0-01	A-82	Screw	2				
A-46	Belt Guard Setter	2	115528-0-01	A-83	Spring Washer	1	028080-2-43			

B. Upper Shaft, Needle Bar Mechanism

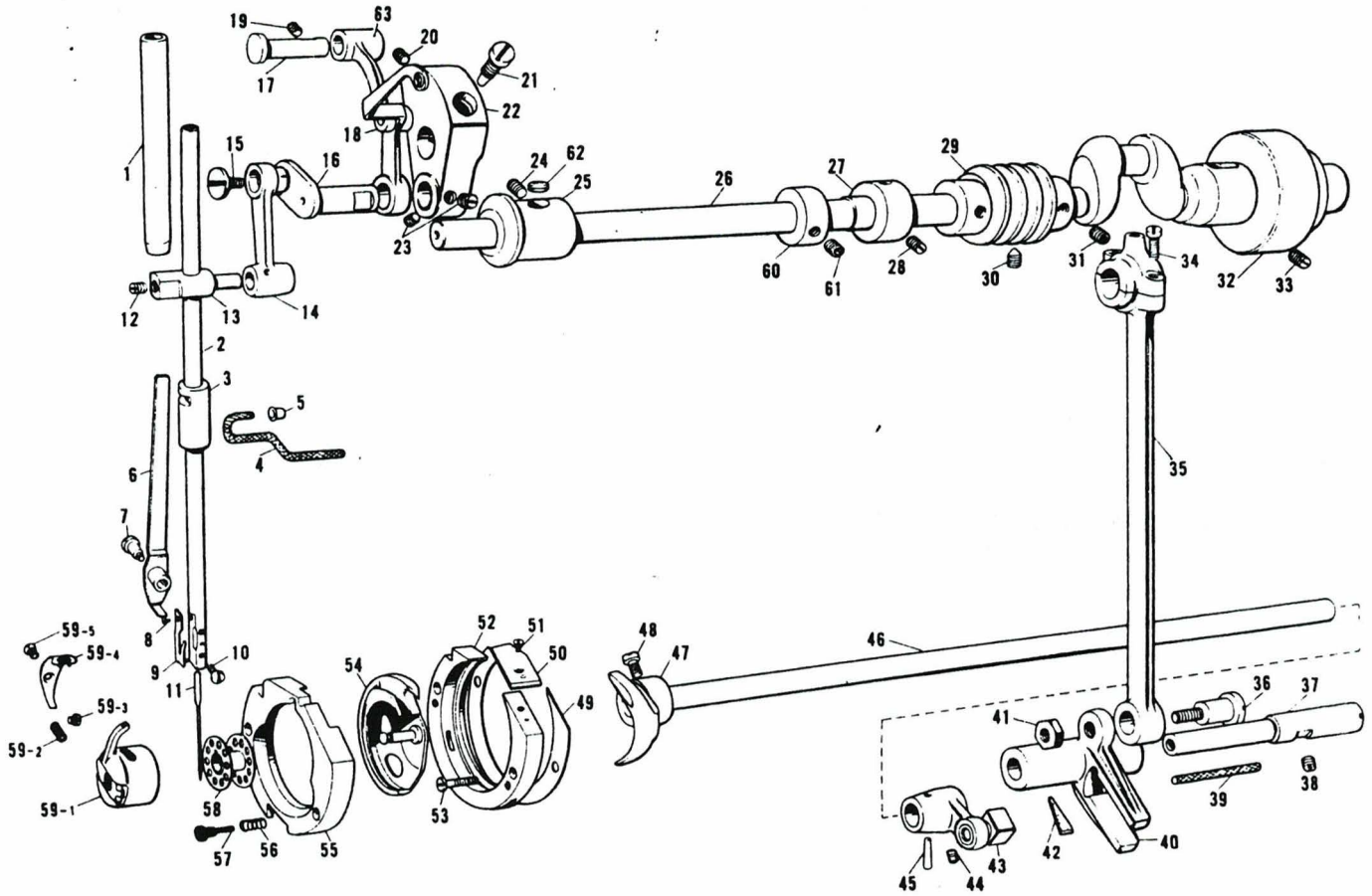

Ref. No.	Name of Parts	Q'ty	Parts No.	Assembly No.	Ref. No.	Name of Parts	Q'ty	Parts No.	Assembly No.
B-1	Needle Bar Bushing Upper	1	111463-0-01		B-34	Screw	2	107428-0-01	
B-2	Needle Bar	1	115401-0-01		B-35	Crank Rod	1	115430-0-01	
B-3	Needle Bar Bushing Lower	1	115402-0-01		B-36	Stud Screw	1	115431-0-01	
B-4	Wick 4 x 4	1	109405-0-01		B-37	Oscillating Rock Shaft	1	115433-0-01	
B-5	Wick Stopper	1	109993-0-01		B-38	Screw	1	013760-8-10	
B-6	Nipper Fastening Plate	1	115403-0-01		B-39	Wick	1	115515-0-01	
B-7	Stud Screw	1	115404-0-01		B-40	Oscillating Rock Body	1	115432-0-01	
B-8	Screw	1	102626-0-05		B-41	Nut	1	104689-0-01	
B-9	Thread Nipper Spring	1	115489-0-01		B-42	Felt	1	115434-0-01	
B-10	Screw	1	009679-3-14		B-43	Slide Block Assembly	1	115435-0-01	
B-11	Needle LQ x 5	1			B-44	Screw	1	013680-6-12	
B-12	Screw	1	013710-7-12		B-45	Taper Pin	1	046301-6-20	
B-13	Needle Bar Clamp	1	115398-0-01		B-46	Shuttle Driver Shaft	1	115438-0-01	
B-14	Needle Bar Crank Rod	1			B-47	Shuttle Driver	1	115612-0-01	
B-15	Screw	1	100253-0-01		B-48	Screw	2	009710-7-13	
B-16	Needle Bar Crank	1			B-49	Shuttle Race Washer	1	117426-0-00	
B-17	Stud	1			B-50	Shuttle Race Thread Guide	1		
B-18	Thread Take-up Lever	1			B-51	Screw	1	100105-0-04	
B-63	Link Take-up Supporter	1			B-52	Shuttle Race	1		
B-19	Screw	1	013761-2-10		B-54	Shuttle Hook	1	116827-0-01	
B-20	Screw	1	013780-7-10		B-55	Shuttle Race Ring	1		
B-21	Stud Screw	1	100250-0-01		B-56	Presser Spring	2	105832-0-00	
B-22	Counter Weight	1	115395-0-00		B-57	Screw	2	105831-0-01	
B-23	Screw	2	101706-0-01		B-53	Screw	2	105827-0-02	
B-24	Screw	1	013761-2-10		B-58	Bobbin	1	100117-0-01	
B-25	Upper Shaft Bushing Left	1	115392-0-00		B-59-1	Bobbin Case	1		
B-26	Upper Shaft	1	115391-0-01		B-59-2	Spring	1	100113-0-00	
B-27	Upper Shaft Bushing Intermediate	1	115393-0-00		B-59-3	Screw	1	100114-0-01	
B-28	Screw	1	013761-2-10		B-59-4	Thread Tension Spring	1	100115-0-01	
B-29	Worm	1			B-59-5	Screw	1	100116-0-02	
B-30	Screw	2	118853-0-01		B-60	Collar	1	117671-0-02	
B-31	Screw	4	014760-6-22		B-61	Screw	2	014770-6-22	
B-32	Upper Shaft Bushing Right	1	115394-0-00		B-62	Felt	1	140560-0-01	
B-33	Screw	1	013761-2-10						

G. Clutch Mechanism

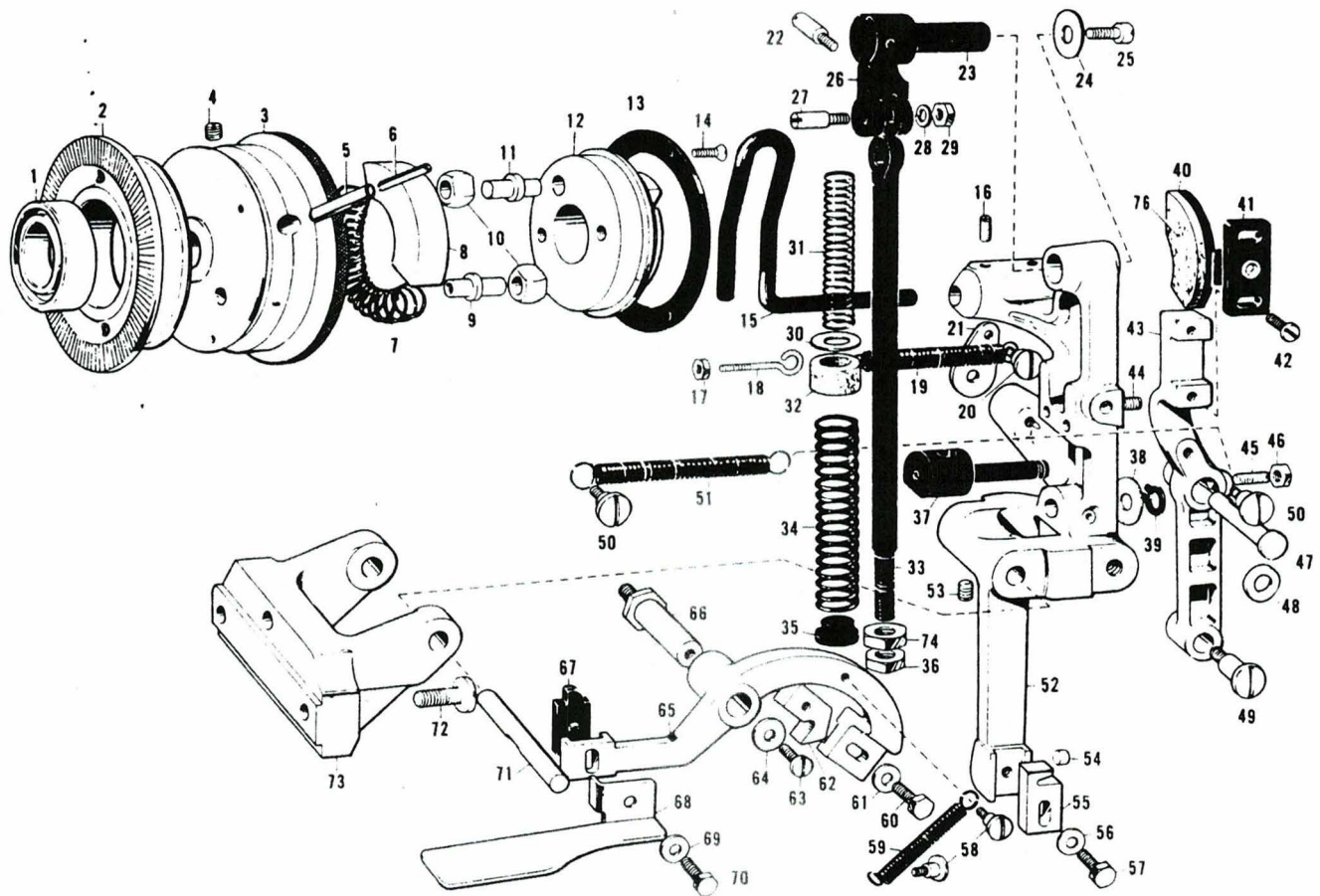

Ref. No.	Name of Parts	Q'ty	Parts No.	Assembly No.	Ref. No.	Name of Parts	Q'ty	Parts No.	Assembly No.
C-1	Ball Bearing	1	072600-4-80		C-38	Washer	1	025100-1-32	
C-2	Idle Pulley	1	118384-0-01		C-39	Stop Ring	1	048100-1-40	
C-3	Drive Pulley	1		Roller Shaft Assembly 182353-0-01	C-40	Brake Shoe Guide	1	115564-0-01	Brake Shoe Assembly 149237-0-01
C-9	Roller Shaft (B)	1			C-41	Brake Shoe Guide Plate	1	115562-0-01	
C-4	Screw	1	014760-6-22		C-76	Brake Shoe	1	115565-0-01	
C-5	Spring Pin	1	047502-2-42		C-42	Screw	2	009681-0-12	
C-6	Spring Pin	1	047302-2-42		C-43	Brake Lever	1	115561-0-01	
C-7	Plunge Spring	1	115426-0-01		C-44	Screw	1	013760-6-10	
C-8	Plunge Spring Holder	1	115427-0-01		C-45	Screw	1	013761-2-10	
C-10	Roller	2	115423-0-01		C-46	Nut	1	150553-0-01	
C-11	Roller Shaft (A) for Stop Cam	1		Stop Cam Assembly 182330-0-01	C-47	Brake Lever Guide Stud	1	115569-0-01	Clutch Lever Assembly 115538-0-01
C-12	Stop Cam	1			C-48	Washer	1	025080-1-32	
C-13	Stop Cam Ring	1	115429-0-01		C-49	Stud Screw	1	115567-0-01	
C-14	Screw	3	117348-0-01		C-52	Clutch Lever	1	115539-0-01	
C-17	Nut	1	021670-2-03		C-54	Clutch Lever Bushing	1	115553-0-01	
C-18	Hook	1	106505-0-01		C-55	Clutch Lever Pawl	1	115540-0-01	
C-19	Clutch Lever Spring	1	115560-0-01		C-56	Washer	1	025060-2-32	
C-20	Stud Screw	1	115559-0-01		C-57	Bolt	1	017762-0-12	
C-15	Belt Shifter	1	115554-0-01		C-74	Nut	1	100075-0-04	
C-16	Screw	2	013761-4-12		C-50	Stud Screw	2	115389-0-01	
C-21	Adjusting Plate	1	115558-0-02		C-51	Brake Spring	1	115570-0-01	
C-22	Clutch Stopper Holder Stud	1	115544-0-01		C-53	Screw	1	013760-8-10	
C-23	Clutch Stopper Holder	1	115542-0-01		C-58	Stud Screw	2	115559-0-01	
C-24	Washer	1	025060-3-32		C-59	Clutch Tripping Lever Spring	1	115580-0-01	
C-25	Screw	1	009761-2-12		C-60	Bolt	1	017761-6-13	
C-26	Clutch Stopper	1	143941-0-01		C-61	Washer	1	025770-2-33	
C-27	Clutch Stopper Stud	1	115546-0-01	Clutch Lever Assembly 115538-0-01	C-62	Clutch Stopper Pawl	1	115577-0-01	Clutch Tripping Lever Assembly 115572-0-01
C-28	Spring Washer	1	028050-2-40		C-65	Clutch Tripping Lever	1	115573-0-01	
C-29	Nut	1	021710-2-02		C-67	Tripping Dog	1	115575-0-01	
C-30	Washer	1	025100-1-32		C-68	Hand Stop Lever	1	115574-0-01	
C-31	Stopper Spring (B)	1	115551-0-01		C-69	Washer	1	025770-2-33	
C-32	Felt	1	115550-0-01		C-70	Bolt	1	017761-2-13	
C-33	Stopper Adjusting Spring Shaft	1	115547-0-01		C-63	Screw	1	009760-8-13	
C-34	Stopper Spring (A)	1	115548-0-01		C-64	Washer	1	025060-3-33	
C-35	Washer	1	115549-0-01		C-66	Stud Screw	1	115579-0-01	
C-36	Nut	1	07860-2-02		C-71	Clutch Lever Shaft	1	115555-0-00	
C-37	Holder	1	115541-0-01		C-72	Screw	3	009872-2-13	
					C-73	Clutch Lever Bracket	1	115556-0-01	

D. Feed, Cam Mechanism

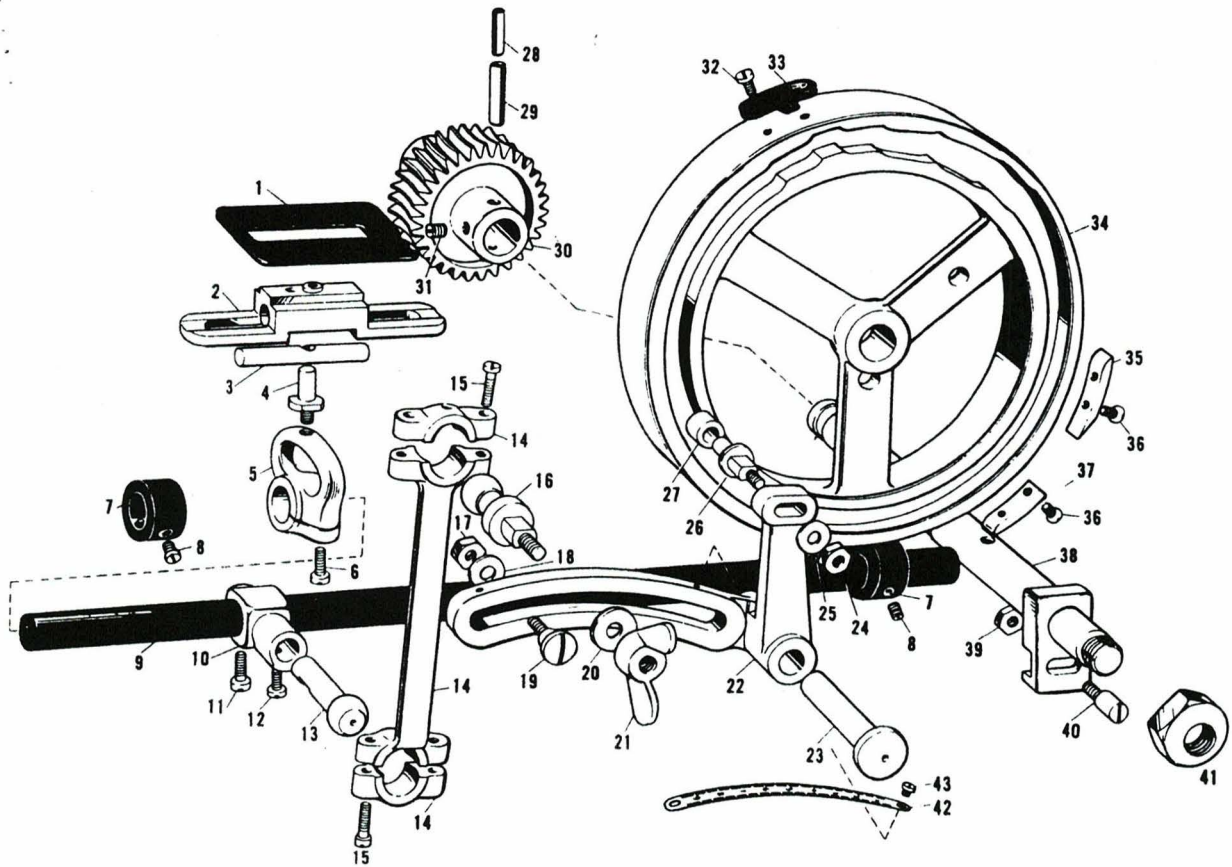

Ref. No.	Name of Parts	Q'ty	Parts No.	Assembly No.	Ref. No.	Name of Parts	Q'ty	Parts No.	Assembly No.
D-1	Feed Across Ring Cover	1	115502-0-01		D-24	Nut	1	107498-0-01	Feed Across Regulator Assembly 115455-0-01
D-2	Feed Across Ring Guide	1	115500-0-01		D-25	Washer	1	025770-2-33	
D-3	Feed Across Ring Guide Shaft	1	115501-0-01		D-26	Roller Stud	1	115457-0-01	
D-4	Feed Across Ring Stud	1	115499-0-01		D-27	Roller	1	147187-0-01	
D-5	Feed Across Ring	1	115498-0-01		D-42	Feed Across Indicator	1	142122-0-01	
D-6	Screw	1	009711-4-13		D-43	Screw	2	009660-3-12	
D-7	Collar	2	115496-0-01		D-23	Feed Across Regulator Shaft	1	115460-0-01	
D-8	Screw	4	104908-0-04		D-28	Spring Pin 3 × 32	1	047303-2-42	
D-9	Feed Across Shaft	1	115495-0-01		D-29	Spring Pin 5 × 32	1	047503-2-42	
D-10	Ball Stud Bracket	1	115497-0-01		D-30	Worm Wheel	1		
D-11	Screw	1	009711-0-13		D-31	Screw	1	014760-6-22	
D-12	Screw	1	009680-7-13		D-32	Screw		009670-5-13	
D-13	Lower Ball Stud	1	*115465-0-01	Ball Stud Assembly 146294-0-01	D-33	Stop Tripping Segment		115451-0-01	Feed Cam Assembly
D-14	Feed Across Rod	1	*115462-0-01		D-34	Feed Cam	1		
D-15	Screw	4	009681-4-14	D-35	Thread Nipper Tripping Segment (B)				
D-16	Upper Ball Stud	1	*115463-0-01	D-36	Screw		140555-0-01		
D-20	Washer	1	142216-0-01	Feed Across Rod Assembly 115461-0-01	D-37	Thread Nipper Tripping Segment (A)			
D-21	Wing Nut	1	115464-0-01		D-38	Worm Wheel Shaft	1	115448-0-01	
D-17	Nut	1	150555-0-02	Feed Across Regulator Assembly 115455-0-01	D-39	Nut	1	150553-0-02	
D-18	Washer	1	025770-2-33		D-40	Stud Screw	1	115449-0-01	
D-19	Stud Screw	1	115389-0-01		D-41	Nut	1	105844-0-03	
D-22	Feed Across Regulator	1	115456-0-01						

E. Feed Mechanism

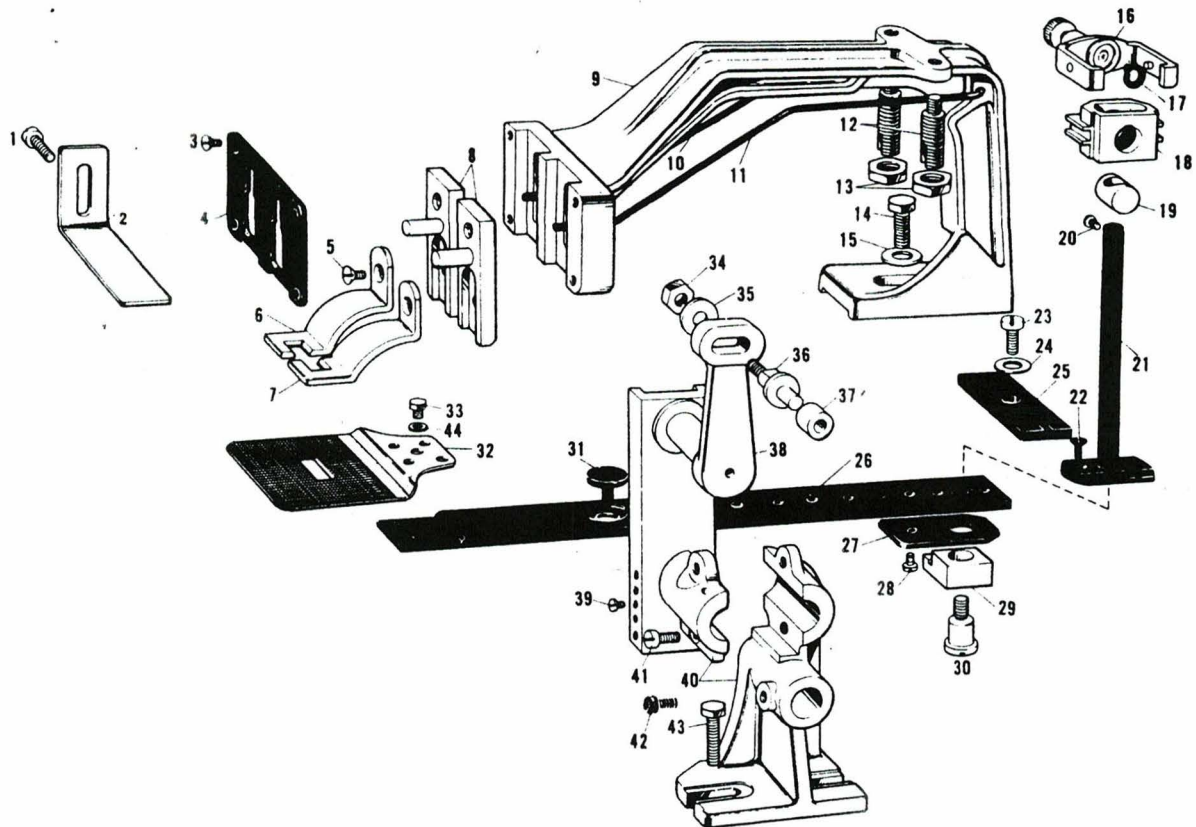

Ref. No.	Name of Parts	Q'ty	Parts No.	Assembly No.	Ref. No.	Name of Parts	Q'ty	Parts No.	Assembly No.	
E-1	Screw	2	009710-7-13	Presser Arm Assembly	E-30	Stud Screw	1	115493-0-01	Feed Bracket Assembly 115466-0-01	
E-2	Presser Arm Guide	1	115414-0-01		E-32	Feed Plate	1			
E-3	Screw		107038-0-01		E-33	Bolt	1	145831-0-01		
E-4	Work Clamp Guide Plate	1	115482-0-01		E-34	Washer	1			
E-5	Screw	2	117143-0-02		E-16	Holder	1	149236-0-01		
E-6	Work Clamp (Left)	1			E-17	Spring Washer	1	028050-2-40		
E-7	Work Clamp (Right)	1			E-18	Feed Lengthwise Adjuster	1	115470-0-01		
E-8	Work Clamp Set Plate	2	149235-0-01		E-19	Screw	1	115471-0-01		
E-9	Presser Arm	1	115477-1-01		E-23	Feed Lengthwise Adjusting Shaft	1	009761-0-12		
E-10	Work Clamp Spring (Left)	1	115484-0-01		E-24	Washer	1	025060-2-33		
E-11	Work Clamp Spring (Right)	1	115483-0-01		E-25	Block Guide Plate	1	115494-0-01		
E-12	Screw	2	115485-0-01		E-31	Screw	1	115503-0-01		
E-13	Nut	2	100075-0-03		E-34	Nut	1	107498-0-01		
E-14	Bolt	1	017761-4-12		E-35	Washer	1	025770-2-33		
E-15	Washer	1	025770-2-33		E-36	Roller Shaft	1	115469-0-01		
E-20	Screw	1	009660-4-12		E-37	Roller	1	147187-0-01		
E-21	Feed Regulator Post	1	115490-0-01		E-38	Feed Lengthwise Regulator	1	115468-0-01		
E-22	Screw	2	102538-0-02		E-39	Screw	1	009660-4-12		
E-26	Feed Plate Carrier	1	115486-0-01		E-40	Feed Bracket	1	115467-0-01		Feed Bracket, 182331-0-00
E-27	Set Plate	1	115491-0-01		E-41	Screw	2	009711-0-13		
E-28	Screw	1	009670-6-13		E-42	Screw	1	013760-6-10		
E-29	Feed Lengthwise Block	1	115492-0-01		E-43	Bolt	2	017761-6-13		

F. Thread Trimmer

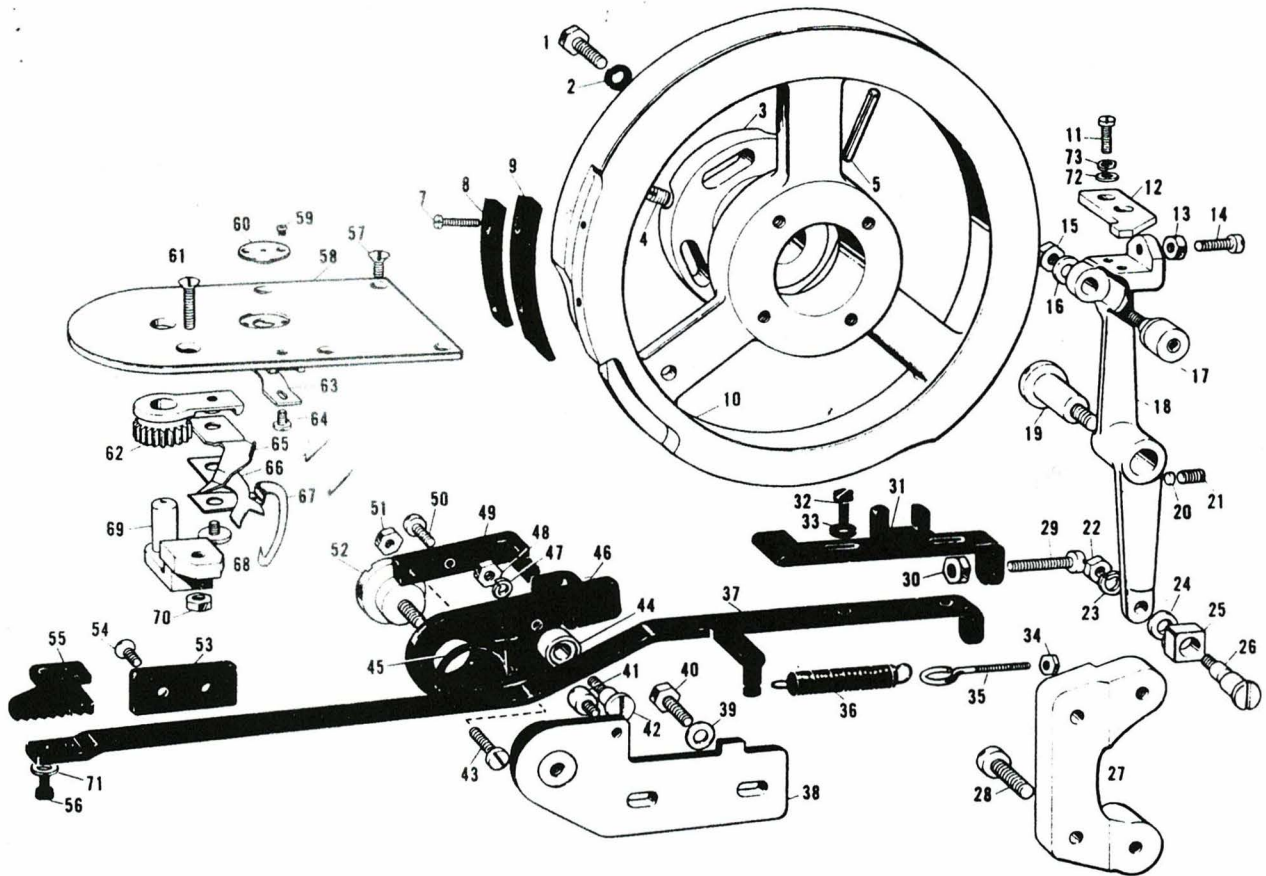

Ref No.	Name of Parts	Qty	Parts No.	Assembly No.	Ref. No.	Name of Parts	Qty	Parts No.	Assembly No.
F-1	Bolt	4	017782-0-12		F-36	Knife Bar Pulling Spring	1	115603-0-01	
F-2	Spring Washer	4	028770-2-40		F-39	Washer	2	025770-2-33	
F-3	Knife Cam Setting Plate	1	115454-0-01		F-40	Bolt	2	017781-4-13	
F-4	Screw	1	013760-8-10		F-38	Guide Plate	1	115518-0-01	
F-5	Spring Pin 5 × 32	1	047503-2-42		F-41	Knife Motion Stopper	1	115601-0-01	
F-7	Screw		009661-4-12		F-42	Stud Screw	1	115488-0-01	
F-8	Knife Guide (B)			Knife Cam Assembly*	F-43	Screw	1	009681-4-13	
F-9	Knife Guide (A)				F-44	Ball Block Operating Roller	1	115445-0-01	
F-10	Knife Cam	1			F-45	Spring	1	115592-0-01	
F-11	Screw	2	009671-0-13		F-46	Knife Operating Lever	1	115408-0-01	
F-12	Vertical Knife Lever Pawl	1	115505-0-01		F-47	Spring Washer	1	028050-2-40	
F-13	Nut	1	022680-3-02		F-48	Nut	1	021710-2-03	
F-14	Screw	1	009681-4-13		F-49	Knife Operating Lever Pawl	1	115415-0-01	
F-15	Nut	1	021750-3-03		F-50	Screw	1	009681-0-12	
F-16	Washer	1	025750-2-33		F-51	Nut	1	021680-2-02	
F-17	Roller	1	181025-0-01		F-52	Stud Screw	1	115598-0-01	
F-18	Vertical Knife Lever	1		Vertical Knife Lever Assembly 116832-0-01	F-53	Guide Plate Knife Bar	1	115517-0-01	
F-22	Nut	1	150552-0-02		F-54	Screw	2	100032-0-04	
F-23	Spring Washer	1	028060-2-42		F-37	Knife Bar	1	115511-0-01	
F-24	Washer	1	115507-0-01		F-55	Knife Bar Rack	1	115512-0-01	
F-25	Vertical Knife Lever Slide Block	1	115506-0-01		F-56	Screw	2	009670-8-13	
F-72	Washer	2	105161-0-03		F-71	Washer	2	105161-0-03	
F-73	Spring Washer	1	028040-2-43		F-57	Screw	4	100032-0-03	
F-19	Screw	1	115510-0-01		F-58	Needle Plate	1	105968-0-01	
F-20	Washer	1	107793-0-00		F-59	Screw	2	147845-0-01	
F-21	Screw	1	013760-7-10		F-60	Needle Hole Insert	1		Needle Hole Insert Assembly
F-26	Stud Screw	1	115508-0-01		F-61	Screw	1	105955-0-01	
F-27	Vertical Knife Lever Bracket	1	115509-0-01		F-62	Knife Carrier Position	1		
F-28	Screw	2	009841-6-13		F-63	Fixed Knife	1	115582-0-01	
F-29	Screw	1	009762-0-13		F-64	Screw	1	105034-0-01	
F-30	Nut	1	022760-3-03		F-65	Lower Thread Cutting Knife	1	115578-0-01	
F-31	Knife Bar Adjusting Plate	1	115513-0-01		F-66	Upper Thread Cutting Knife	1	115581-0-01	
F-32	Screw	2	117363-0-01		F-67	Thread Retainer	1	115474-0-01	
F-33	Washer	2	025710-1-32		F-68	Screw	1	105965-0-02	
F-34	Nut	2	021670-2-03		F-69	Pinion Stud Bracket Assembly	1		
F-35	Hook	1	115516-0-01		F-70	Nut	1	021680-2-02	

G. Presser Mechanism

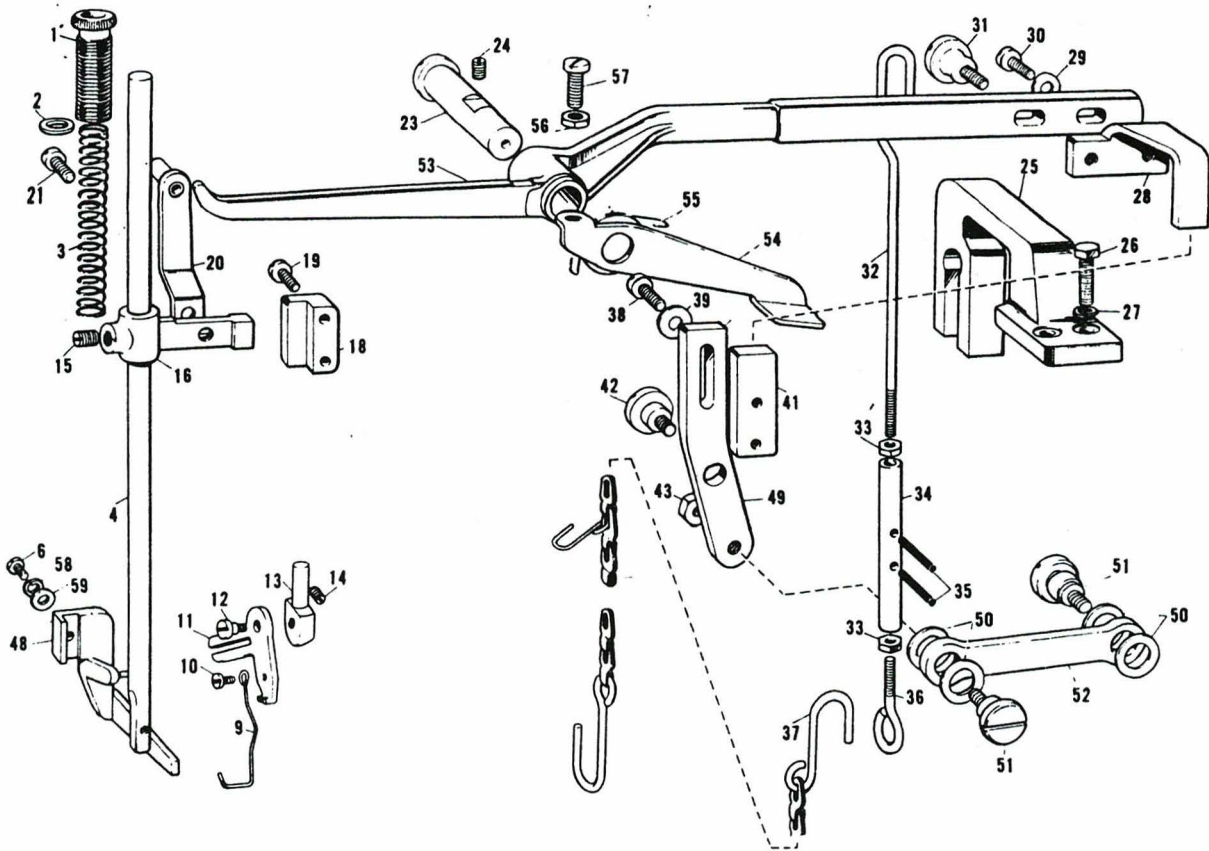

Ref. No.	Name of Parts	Q'ty	Parts No.	Assembly No.	Ref. No.	Name of Parts	Q'ty	Parts No.	Assembly No.
G- 1	Presser Adjusting Screw	1	100496-0-01		G-31	Stud Screw	1	115514-0-01	
G- 2	Presser Spring Washer	1	141099-0-01		G-32	Presser Bar Connecting Bar	1	115458-0-01	
G- 3	Presser Spring	1	100280-0-01		G-33	Nut	2	021710-2-03	
G- 4	Presser Bar	1	103013-0-01		G-34	Adjusting Rod	1	115459-0-01	
G- 6	Screw	1	009671-0-13		G-35	Spring Pin	2	047302-2-42	
G- 9	Thread Reciprocater	1	115591-0-01		G-36	Hook	1	115537-0-01	
G-10	Screw	1	009639-4-14	Thread Reciprocater Assembly 115589-0-01	G-37	Lifting Lever Connecting Chain (A)	1	105333-0-01	
G-11	Thread Reciprocating Arm	1	115590-0-01		G-38	Screw	2	009761-2-13	
G-12	Stud Screw	1	106011-0-01		G-39	Washer	2	025060-2-33	
G-13	Thread Reciprocating Stud	1	106008-0-01		G-41	Lifting Stop Lever Pawl	1	115534-0-01	
G-14	Screw	1	013711-0-10		G-42	Stud Screw	1	115602-0-01	
G-15	Screw	1	013780-8-10		G-43	Nut	1	150552-0-01	
G-16	Presser Bar Guide	1	115521-0-01		G-48	Work Clamp Lifter Holder	1	118577-0-01	
G-18	Presser Bar Guide Plate	1	115525-0-01		G-49	Lifting Stop Lever	1	115533-0-01	
G-19	Screw	2	009681-2-13		G-50	Washer	4	118236-0-00	
G-20	Presser Bar Lifting Arm	1	115625-0-01		G-51	Stud Screw	2	115519-0-01	
G-21	Screw	1	009710-7-13	G-52	Lifting Stop Lever Connector	1	118235-0-01		
G-23	Lifting Lever Guide Stud	1	115530-0-01	G-53	Lifting Lever	1	115529-0-01		
G-24	Screw	1	014760-6-22	G-54	Nipper Driver	1	118199-0-01		
G-25	Lifting Lever Guide	1	115531-0-01	G-55	Spring	1	118202-0-01		
G-26	Bolt	2	017761-6-13	G-56	Nut	1	150553-0-02		
G-27	Washer	2	028060-2-42	G-57	Screw	1	009761-4-13		
G-28	Lifting Lever Stopper	1	115532-0-01	G-58	Spring Washer	1	028040-2-43		
G-29	Washer	1	025060-3-33	G-59	Washer	1	025350-3-33		
G-30	Screw	1	009761-4-13						

H. Threading Mechanism

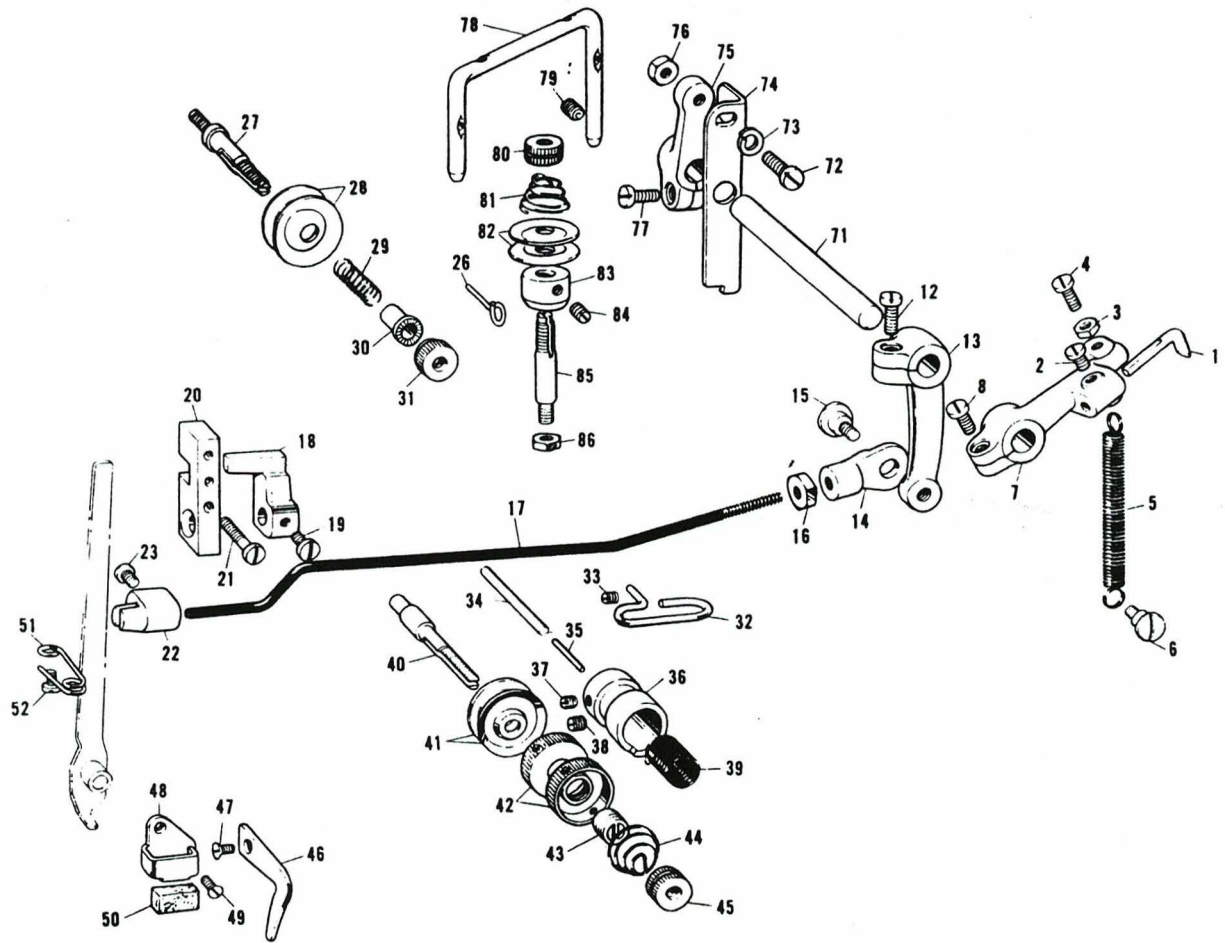

Ref. No.	Name of Parts	Q'ty	Parts No.	Assembly No.	Ref. No.	Name of Parts	Q'ty	Parts No.	Assembly No.
H- 1	Nipper Operating Lever Pawl	1	115407-0-01		H-38	Screw	1	013760-8-10	
H- 2	Screw	1	009680-6-13		H-39	Check Spring	1	100399-0-01	
H- 3	Nut	1	021710-2-03		H-40	Thread Tension Stud	1	115594-0-01	
H- 4	Screw	1	009712-0-13		H-41	Thread Tension Disc	2	145446-0-01	
H- 5	Spring	1	115412-0-01		H-42	Knob	2	117487-0-01	
H- 6	Stud Screw	1	115559-0-01		H-43	Screw	1	117488-0-01	
H- 7	Nipper Operating Lever	1	115406-0-01		H-44	Tension Spring	1	104525-0-01	
H- 8	Screw	1	009711-2-13		H-45	Tension Control Nut	1	100136-0-01	
H-12	Screw	1	009711-2-13		H-46	Thread Guide Plate	1	115595-0-01	
H-13	Nipper Operating Connecting Lever	1	115409-0-01		H-47	Screw	1	108960-0-04	
H-14	Joint	1	104842-0-01		H-48	Arm Thread Guide	1	117770-0-01	
H-15	Stud Screw	1	106149-0-02		H-49	Screw	1	108960-0-04	
H-16	Nut	1	021710-2-03		H-50	Felt	1	117771-0-01	
H-17	Nipper Operating Connecting Rod	1	115416-0-01		H-51	Arm Thread Guide Lower	1	115610-0-01	
H-18	Thread Tension Release	1	115419-0-01		H-52	Screw	1	009660-6-13	
H-19	Screw	1	009670-6-13		H-71	Nipper Operating Lever Shaft	1	115410-0-01	
H-20	Nipper Operating Connecting Rod Bracket	1	115418-0-01		H-72	Screw	1	009711-4-13	
H-21	Screw	2	009671-6-13		H-73	Spring Washer	1	028050-2-40	
H-22	Nipper Fastening Plate Pusher	1	115417-0-01		H-74	Nipper Adjusting Plate	1	118201-0-01	
H-23	Screw	1	009670-6-13		H-75	Nipper Adjusting Lever	1	118200-0-01	
H-26	Thread Guide	1	115606-0-01		H-76	Nut	1	021710-2-03	
H-27	Sub Tension Stud	1	113740-0-01		H-77	Screw	1	009711-2-13	
H-28	Tension Disc	2	145446-0-01		H-78	Top Cover Thread Guide	1	118406-0-01	
H-29	Sub Tension Spring	1	105278-0-00		H-79	Screw	1	013710-7-12	
H-30	Sub Tension Washer	1	144105-0-00		H-80	Tension Control Nut	1	100136-0-01	
H-31	Sub Tension Control Nut	1	105230-0-01		H-81	Tension Spring	1	104525-0-01	
H-32	Arm Thread Guide Upper	1	115571-0-01		H-82	Tension Disc	2	145446-0-01	
H-33	Screw	1	013660-6-10		H-83	Tension Stud Collar	1	118405-0-01	
H-34	Tension Release Guide Pin	1	115600-0-01		H-84	Screw	2	013680-6-12	
H-35	Thread Tension Release Pin	1	115599-0-01		H-85	Tension Stud	1	118404-0-01	
H-36	Thread Tension Bracket	1	115593-0-01		H-86	Nut	1	150556-0-02	
H-37	Screw	1	013679-4-12						

Tension Stud Assembly
118403-0-01

Z. Accessories

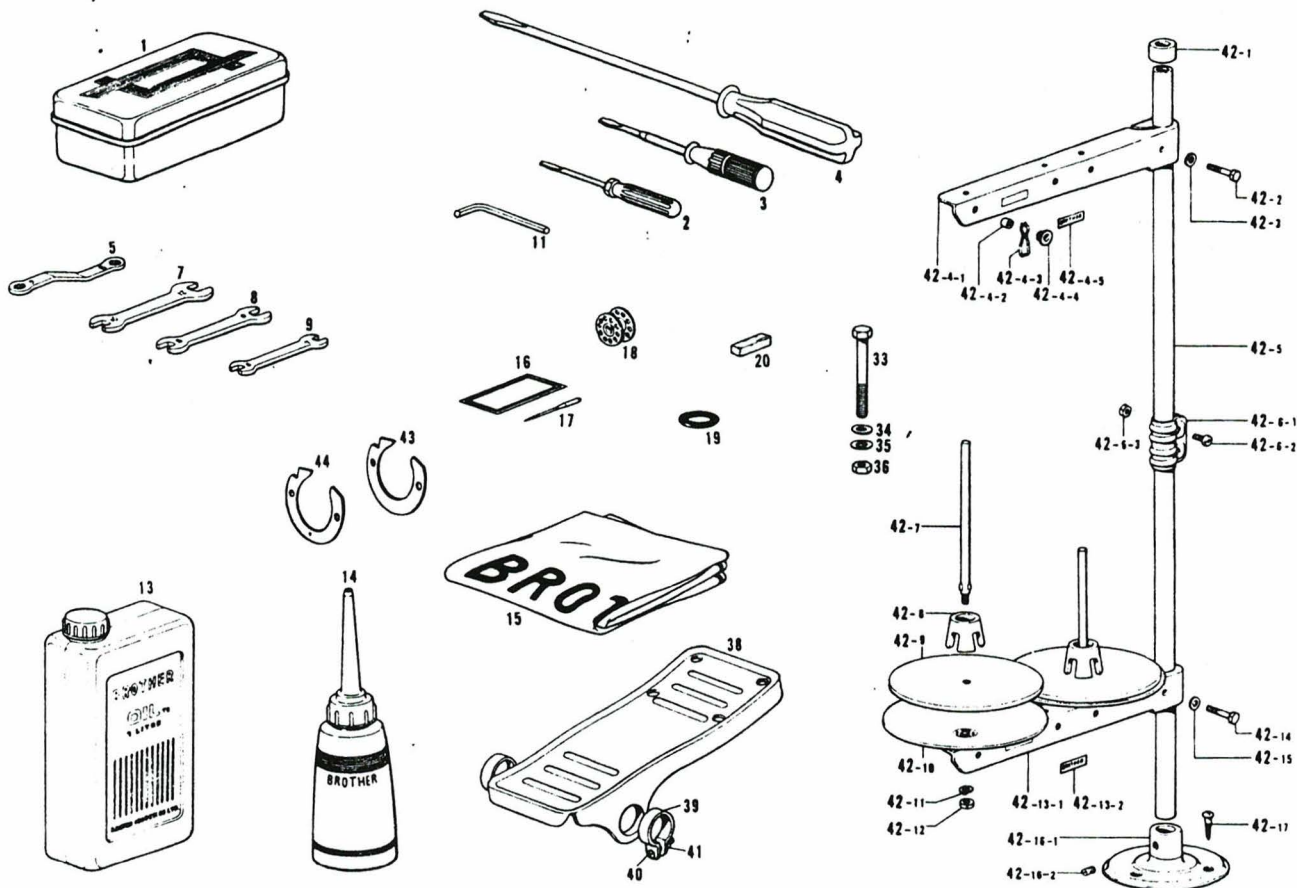

Ref. No.	Name of Parts	Q'ty	Parts No.	Assembly No.	Ref. No.	Name of Parts	Q'ty	Parts No.	Assembly No.
Z- 1	Accessory Box		110436-0-01		Z-42-4-1	Spool Holder		150178-0-01	Z-42-4 Thread Hanger Assembly 150192-0-01
Z- 2	Screw Driver 2.6 × 40		142443-0-01		Z-42-4-2	Thread Bushing		142990-0-01	
Z- 3	Screw Driver 5.5 × 75		118837-0-01		Z-42-4-3	Thread Guide Spring		150184-0-01	
Z- 4	Screw Driver 6.4 × 204		101572-1-01		Z-42-4-4	Thread Hanger		150183-0-00	
Z- 5	Spanner 8 × 9		105343-0-01		Z-42-4-5	Name Plate		143000-0-01	
Z- 7	Wrench 10 × 12		107780-0-01		Z-42- 5	Pipe		150172-0-01	Z-42-6 Joint Assembly 150106-0-01
Z- 8	Wrench 8 × 9		100887-0-01		Z-42-6-1	Joint		150173-0-01	
Z- 9	Wrench 6 × 7		107779-0-01		Z-42-6-2	Screw		150202-0-01	
Z-11	Allen Wrench (3 mm)		142721-0-01		Z-42-6-3	Nut		021500-1-03	
Z-13	Oil Tank		145277-1-03		Z-42- 7	Spool Shaft		150179-0-01	
Z-14	Oiler		114483-0-01		Z-42- 8	Spool Cushion		147060-0-01	Z-42-13 Spool Holder Assembly 150177-0-01
Z-15	Head Cover		144226-0-01		Z-42- 9	Spool Mat		150182-0-00	
Z-16	Needle Bag				Z-42-10	Spool Stand Base		150180-0-00	
Z-17	Needle LQ × 5				Z-42-11	Spring Washer		028050-2-43	
Z-18	Bobbin		100117-0-01		Z-42-12	Nut		021500-1-03	
Z-19	Rubber Ring		120448-0-01		Z-42-13-1	Spool Holder 2		150178-0-01	Z-42-16 Cotton Stand Base Assembly 150139-0-01
Z-20	Felt		117771-0-01		Z-42-13-2	Name Plate		143000-0-01	
Z-33	Bolt		144543-0-01		Z-42-14	Bolt		017502-8-03	
Z-34	Washer		025060-2-32		Z-42-15	Washer		025050-2-33	
Z-35	Washer		115947-0-01		Z-42-16-1	Cotton Stand Base		150189-0-01	
Z-36	Nut		021060-1-02		Z-42-16-2	Screw		150181-0-01	Z-42-17 Screw Z-43 Shuttle Race Washer Z-44 Shuttle Race Washer
Z-38	Foot Pedal		117437-1-01	Foot Pedal Assembly 2 pieces 116185-2-01	Z-42-17	Screw		031452-2-03	
Z-39	Foot Pedal Stopper		116016-0-01		Z-43	Shuttle Race Washer		112828-0-00	
Z-40	Screw		001401-4-16		Z-44	Shuttle Race Washer			
Z-41	Nut		021400-1-06						
Z-42- 1	Cap			Z-42 Cotton Stand Assembly 150150-0-01					
Z-42- 2	Bolt		017502-8-03						
Z-42- 3	Washer		025050-2-33						

* The details of included accessories are subject to change.

* Änderungen in der Aufstellung der mitgelieferten Zubehöre sind vorbehalten.

* Les détails des accessoires inclus sont sujets à des changements.

* Los detalles de los accesorios incluidos pueden variar.

SEPARATE PARTS LIST

Ref. No.	Name of Parts	Specification	826-1	826-3A	826-5A	826-3B	826-5B
B-11	Needle LQ × 5		105771-0-16	105771-0-11		105771-0-16	
B-29	Worm		115420-0-01	117502-0-01	115420-0-01	117502-0-01	115420-0-01
D-30	Worm Wheel		115447-0-01	117503-0-01	115447-0-01	117503-0-01	115447-0-01
D-32-37	Feed Cam Assembly		116829-0-01	117489-0-01	118272-0-01	117489-0-01	118272-0-01
D-34	Feed Cam		115450-0-01	117490-0-01	118205-0-01	117490-0-01	118205-0-01
D-35	Thread Nipper Tripping Segment (B)		115568-0-01	117492-0-01	115568-0-01	117492-0-01	115568-0-01
D-37	Thread Nipper Tripping Segment (A)		115452-0-01	117491-0-01	115452-0-01	117491-0-01	115452-0-01
E-3-15 20-22 26-30 32-33-44	Presser Arm Assembly		115476-0-01	118530-0-01		117524-0-01	
E-6	Work Clamp (Left)		115479-0-01	118532-0-01		117498-0-01	
E-7	Work Clamp (Right)		115478-0-01	118531-0-01		117497-0-01	
E-32	Feed Plate		115487-0-01	118533-0-01		117499-0-01	
E-44	Washer		025710-1-32	113431-0-02		025710-1-32	
F-7-10	Knife Cam Assembly		116830-0-01	117493-0-01	118273-0-01	117493-0-01	118273-0-01
F-8	Knife Guide (B)		115597-0-01	117496-0-01	115597-0-01	117496-0-01	115597-0-01
F-9	Knife Guide (A)		115596-0-01	117495-0-01	115596-0-01	117495-0-01	115596-0-01
F-10	Knife Cam		115453-0-01	117494-0-01	118206-0-01	117494-0-01	118206-0-01
F-58-60	Needle Hole Insert Assembly		182374-0-01	182097-0-01		182374-0-01	
F-60	Needle Hole Insert		118872-0-01	105969-0-01		118872-0-01	
Z-17	Needle LQ × 5		105771-0-16	105771-0-11		105771-0-16	
Z-44	Shuttle Race Washer		117426-0-00			117426-0-00	
B-49	Shuttle Race Washer		1	2		1	
D-32	Screw		2	4		2	4
D-33	Stop Tripping Segment		1	2		1	2
D-35	Thread Nipper Tripping Segment (B)		1	2		1	2
D-36	Screw		4	8		4	8
D-37	Thread Nipper Tripping Segment (A)		1	2		1	2
E-3	Screw		4			1	
F-7	Screw		2	4		2	4
F-8	Knife Guide (B)		1	2		1	2
F-9	Knife Guide (A)		1	2		1	2