

CONSEW *Since 1898*®

Model

14TU

Parts Book

A

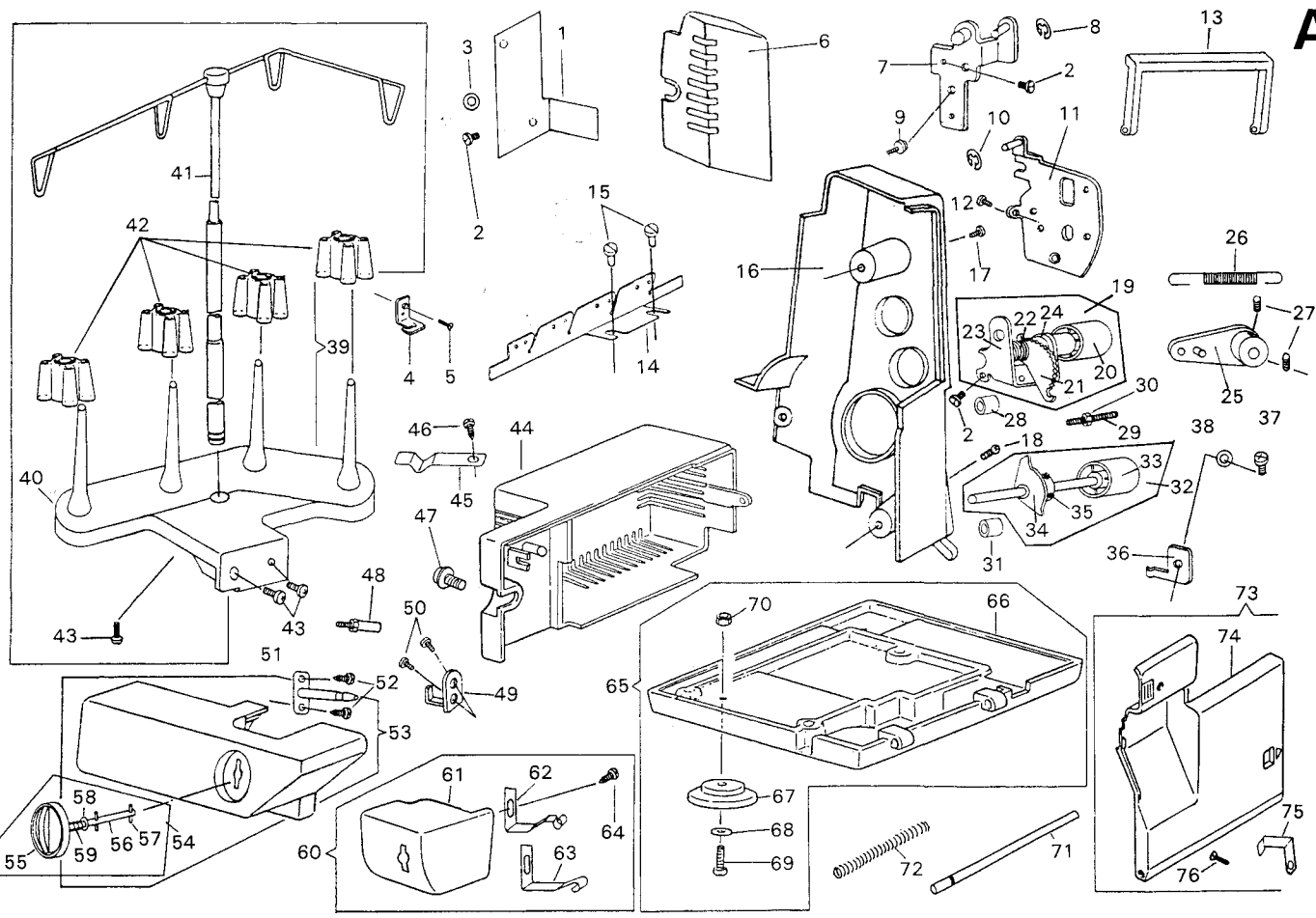

A

KEY	DESCRIPTION	KEY	DESCRIPTION
1	Reflection aluminum plate	40	Thread reel stand
2	+ - binding head screw 4 x 6	41	Thread reel bar complete
3	Plain washer	42	Conr holder
4	Needle thread guide	43	+ - binding head screw 4 x 8
5	Flat head screw 3 x 6	44	Motor cover
6	Light cover	45	Spring plate
7	Handle shaft set plate	46	+ pan head screw 4 x 10
8	Snap ring E-3	47	Washer screw 4 x 10
9	Washer screw 4 x 10	48	Extension table set screw
10	Snap ring E-4	49	Extension table set plate
11	Lamp socket plate	50	+ - binding head screw 4 x 6
12	+ - pan head screw 4 x 6	51	Guide shaft
13	Handle	52	+ pan head screw 4 x 10
14	Thread guide plate	53	Extension table
15	+ - pan head screw 4 x 6	54	Extension table set knob complete
16	Belt cover	55	Knob
17	+ - binding head screw 4 x 6	56	knob shaft
18	+ - binding head screw 4 x 8	57	Spring pin 2.5 x 14
19	Feed regulator dial complete	58	Plain washer 6x11.3x0.4
20	Feed regulator knob shaft	59	Knob shaft spring
21	Feed regulator plate	60	Cylinder cover complete
22	Feed regulator plate spring	61	Cylinder cover
23	Feed regulator bracket	62	Cylinder cover spring (upper)
24	Hexagon socket screw 4 x 4	63	Cylinder cover spring (lower)
25	Feed regulator shaft bracket	64	+ pan head screw 4 x 10
26	Feed regulator spring	65	Base complete
27	Hexagon socket screw 4 x 4	66	Base
28	Feed regulator bushing	67	Rubber cushion
29	Set screw M4 x 0.7 x 25L	68	Plain washer 6x11.3x0.4
30	Nut 4-3-7	69	+ - pan head screw 5 x 10
31	Differential regulator bushing	70	Nut 5-1-8
32	Differential regulator dial complete	71	Looper cover hinge pin
33	Differential regulator knob shaft	72	Looper cover hinge spring
34	Differential regulator plate	73	Looper cover complete
35	Hexagon socket screw 4 x 4	74	Looper cover
36	Spring plate	75	Looper cover set plate
37	+ - binding head screw 4 x 6	76	Set screw
38	Plain washer 4.2x0.8x8	77	Snap ring E-2.5
39	Thread unwinder complete		

B

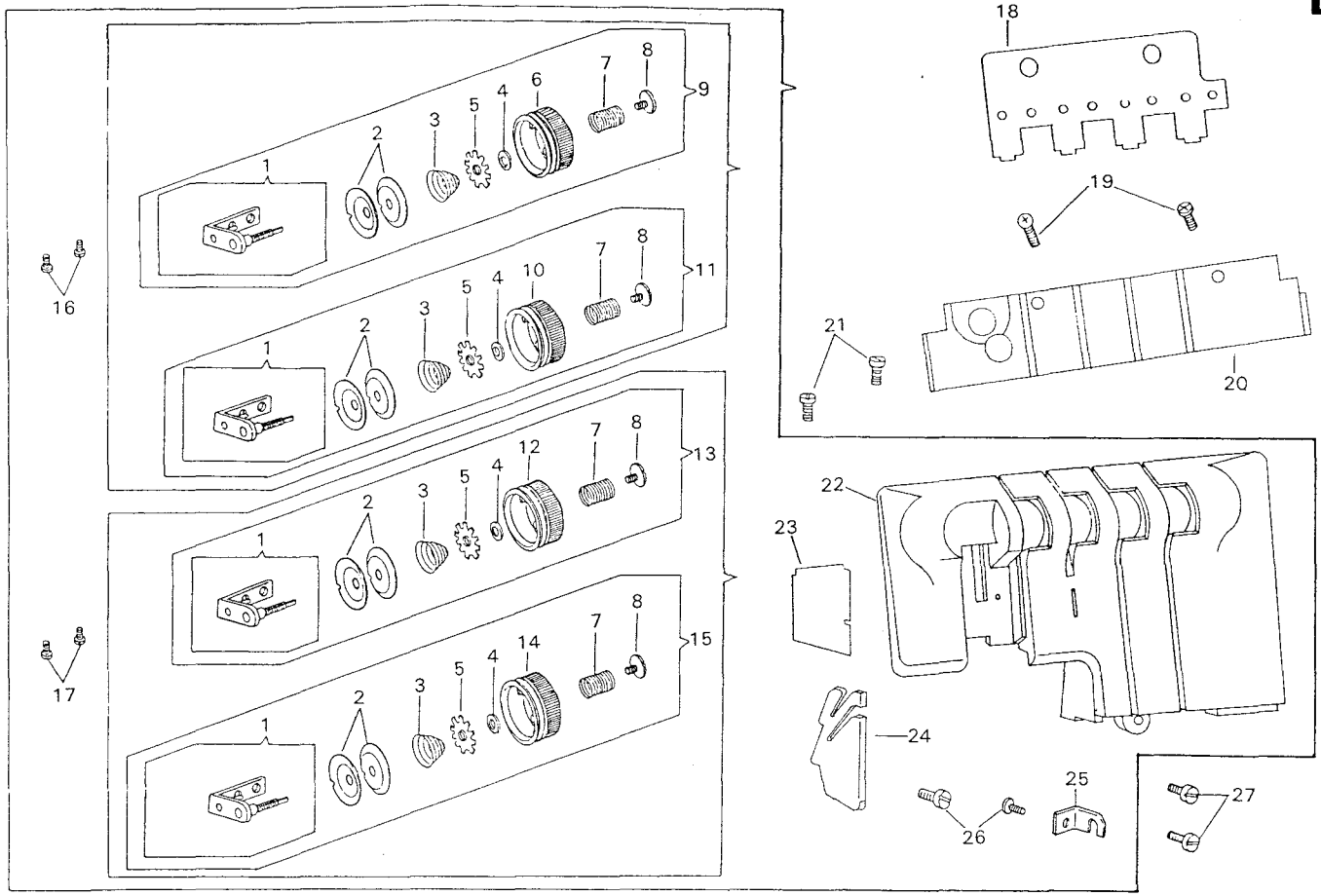

B

KEY	DESCRIPTION	KEY	DESCRIPTION
1	Tension dial bracket		
2	Tension disc		
3	Tension disc spring		
4	Washer		
5	Tension disc spring nut		
6	Dial tension knob		
7	Presser spring		
8	Presser spring screw		
9	Dial tension complete (blue)		
10	Dial tension knob (green)		
11	Dial tension complete (green)		
12	Dial tension knob (orange)		
13	Dial tension complete (orange)		
14	Dial tension knob (yellow)		
15	Dial tension complete (yellow)		
16	Set screw 4 x 10		
17	Set screw 4 x 10		
18	Tension complete set plate		
19	+/- binding head screw 4 x 5		
20	Top plate		
21	+/- binding head screw 4 x 6		
22	Front cover		
23	Reflection aluminum plate		
24	Front cover thread guide (for 2 needle)		
25	Front cover thread guide (small)		
26	+ pan head screw 4 x 10-2		
27	Washer screw 4 x 10		

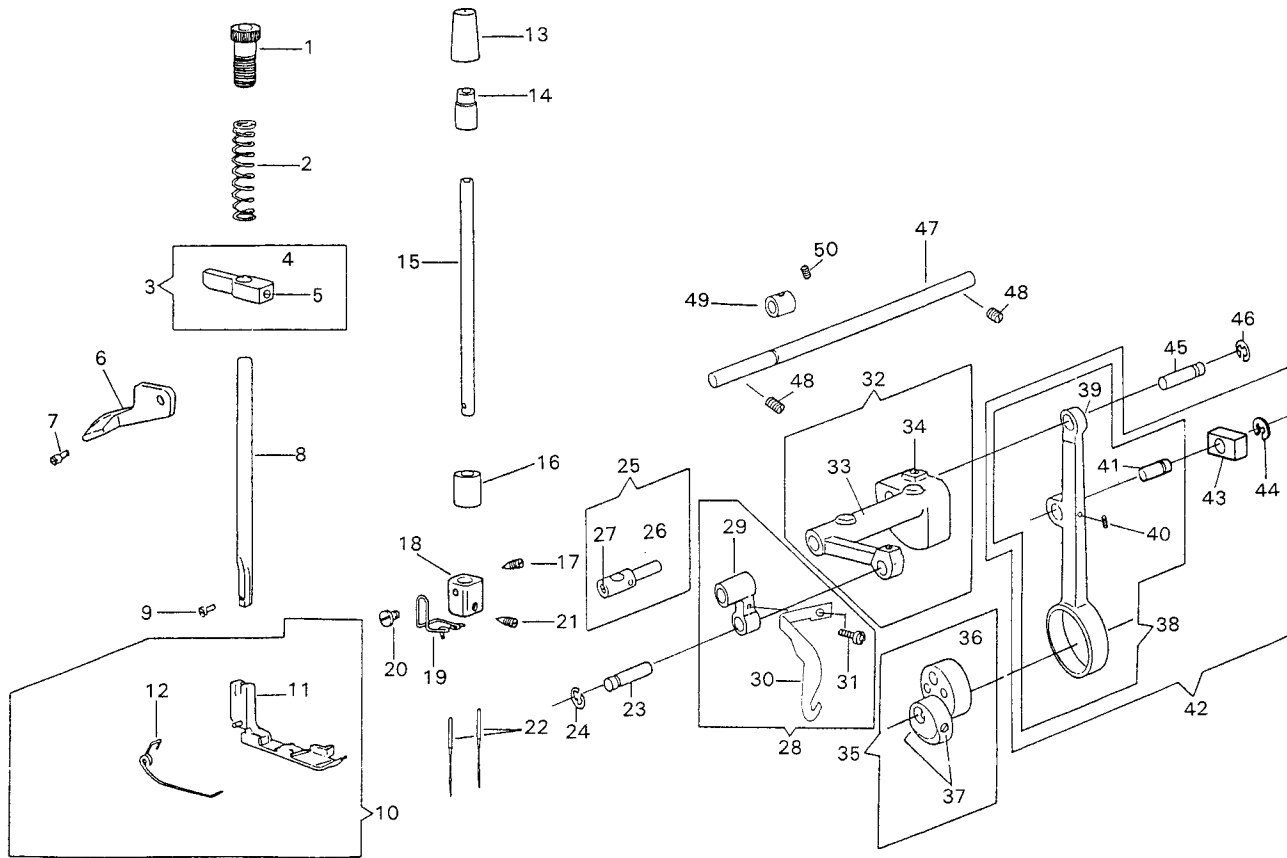

KEY	DESCRIPTION	KEY	DESCRIPTION
1	Presser regulating thumb screw	40	Hexagon socket screw 4 x 4
2	Presser bar spring	41	Needle bar crank rod slide block pin
3	Presser bar guide bracket complete	42	Needle bar crank rod complete
4	Presser bar guide bracket	43	Needle bar crank rod slide block
5	Hexagon socket screw 5 x 5	44	Snap ring E-4
6	Presser bar lifter	45	Needle bar crank rod pin
7	Presser bar lifter hinge screw	46	Snap ring E-4
8	Presser bar	47	Arm shaft
9	Presser foot thumb screw	48	Hexagon socket screw 5 x 5
10	Presser foot complete	49	Arm shaft bushing
11	Presser foot	50	Hexagon socket screw 4 x 4
12	Presser foot spring		
13	Needle bar bushing cap (upper)		
14	Needle bar bushing (upper)		
15	Needle bar		
16	Needle bar bushing (lower)		
17	Needle set screw		
18	Needle clamp		
19	Needle clamp thread guide		
20	Needle clamp thread guide set screw		
21	Needle set screw		
22	Needle		
23	Needle bar connecting link pin		
24	Snap ring E-4		
25	Needle bar connecting stud complete		
26	Needle bar connecting stud		
27	Hexagon socket screw 5 x 5		
28	Needle bar connecting link complete		
29	Needle bar connecting link		
30	Needle thread take-up		
31	+ flat head screw 4 x 8		
32	Needle bar crank complete		
33	Needle bar crank		
34	Hexagon socket screw 4 x 4		
35	Needle bar eccentric cam complete		
36	Needle bar eccentric cam		
37	Hexagon socket screw 4 x 4		
38	Needle bar crank rod complete		
39	Needle bar crank rod		

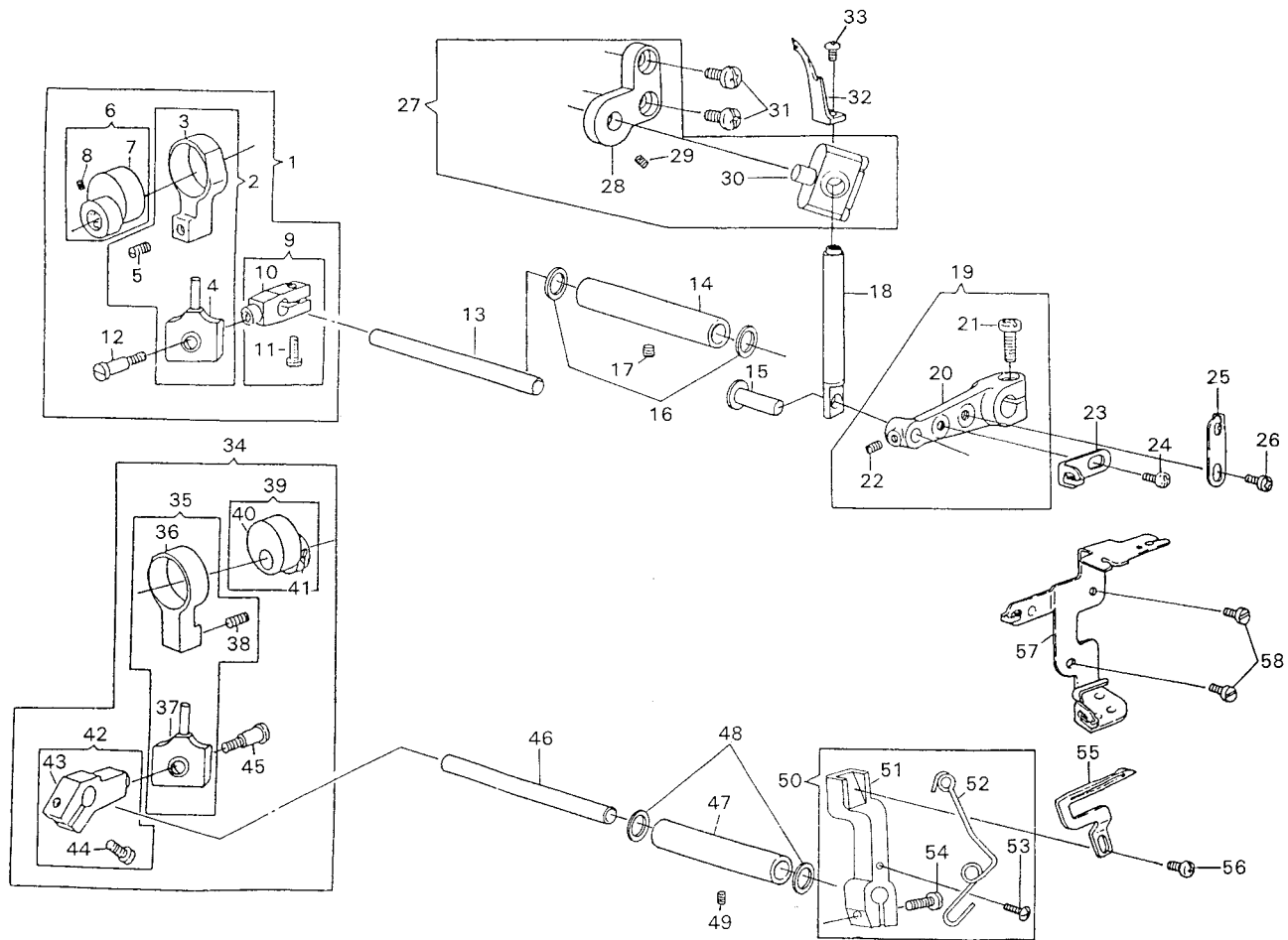

D

KEY	DESCRIPTION	KEY	DESCRIPTION
1	Right looper cam rod complete	40	Looper cam
2	Looper cam rod (complete)	41	Hexagon socket screw 4 x 4
3	Looper cam rod	42	Left looper shaft lever complete
4	Rod end	43	Left looper shaft lever
5	Hexagon socket screw 5 x 5	44	Left looper shaft screw
6	Looper cam complete	45	Screw stud
7	Looper cam	46	Left looper shaft
8	Hexagon socket screw 4 x 4	47	Left looper shaft bushing
9	Right looper shaft lever complete	48	Left looper shaft bushing thrust washer
10	Right looper shaft lever	49	Hexagon socket screw 5 x 5
11	Right looper shaft lever screw 5 x 12	50	Left looper holder complete
12	Screw stud	51	Left looper holder
13	Right looper shaft	52	Left looper holder thread guide
14	Right looper shaft bushing	53	Left looper holder thread guide screw
15	Right looper retainer driving stud	54	Left looper holder clamping screw 5 x 12
16	Right looper shaft bushing thrust washer	55	Left looper
17	Hexagon socket screw 5 x 5	56	Left looper screw
18	Right looper retainer	57	Looper thread guide
19	Right looper retainer driving lever complete	58	+ - pan head screw 4 x 6
20	Right looper retainer driving lever		
21	Right looper retainer driving lever clamping screw		
22	Hexagon socket screw 4 x 4		
23	Left looper thread guide		
24	+ - pan head screw 4 x 6		
25	Right looper thread guide		
26	+ - pan head screw 4 x 6		
27	Right looper retainer guide bracket complete		
28	Right looper retainer guide bracket		
29	Hexagon socket screw 3 x 4		
30	Right looperretainer guide		
31	Right looper retainer guide bracket screw 5 x 6		
32	Right looper		
33	Right looper screw		
34	Left looper cam rod complete		
35	Looper cam rod complete		
36	Looper cam rod		
37	Rod end		
38	Hexagon socket screw 5 x 5		
39	Looper cam complete		

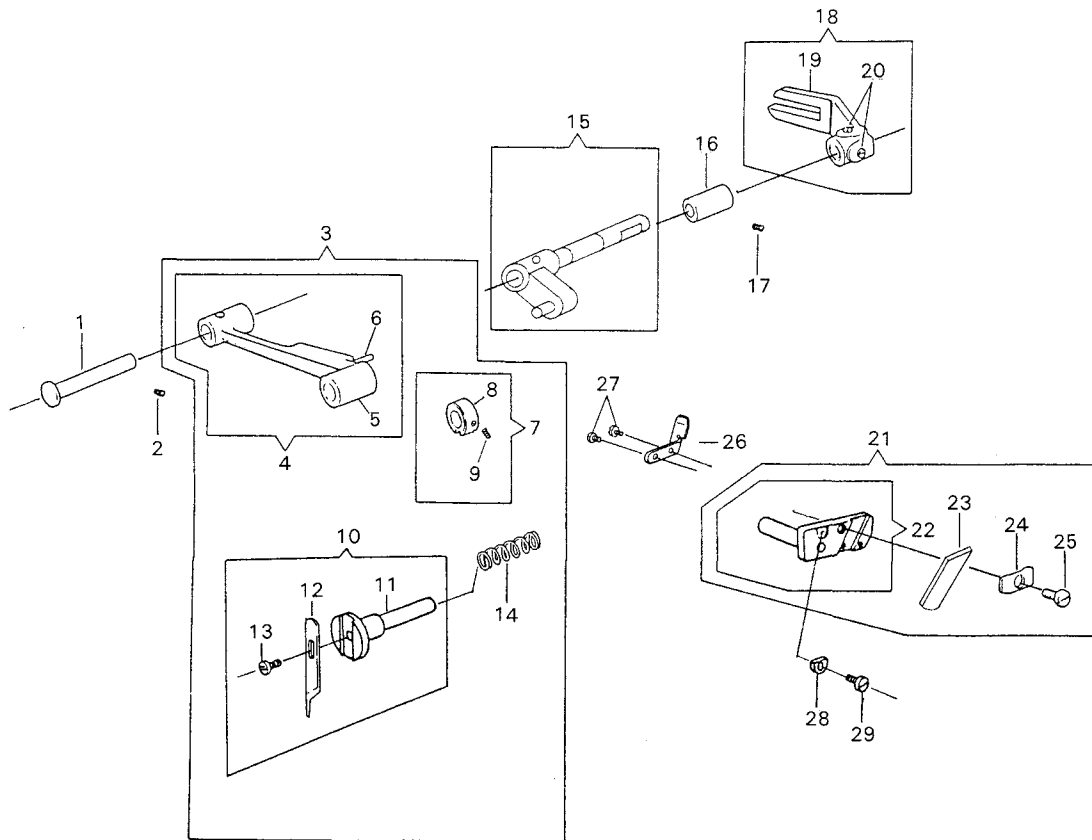

E

KEY	DESCRIPTION	KEY	DESCRIPTION
1	Upper knife lever hinge stud		
2	Hexagon socket screw 5 x 5		
3	Upper knife lever unit		
4	Upper knife lever complete		
5	Upper knife lever		
6	Spring pin 3 x 14		
7	Upper knife holder collar complete		
8	Upper knife holder collar		
9	Hexagon socket screw 4 x 4		
10	Upper knife complete		
11	Upper knife holder		
12	Upper knife		
13	Upper knife set screw		
14	Upper knife holder spring		
15	Upper knife lever driving arm		
16	Upper knife forked lever stud bushing		
17	Hexagon socket screw 5 x 5		
18	Upper knife forked lever complete		
19	Upper knife forked lever		
20	Hexagon socket screw 5 x 5		
21	Lower knife complete		
22	Lower knife holder		
23	Lower knife		
24	Lower knife clamping plate		
25	Lower knife clamping plate screw		
26	Needle guard		
27	Needle guard set screw		
28	Lower knife holder positioning plate		
29	Lower knife holder positioning plate screw		

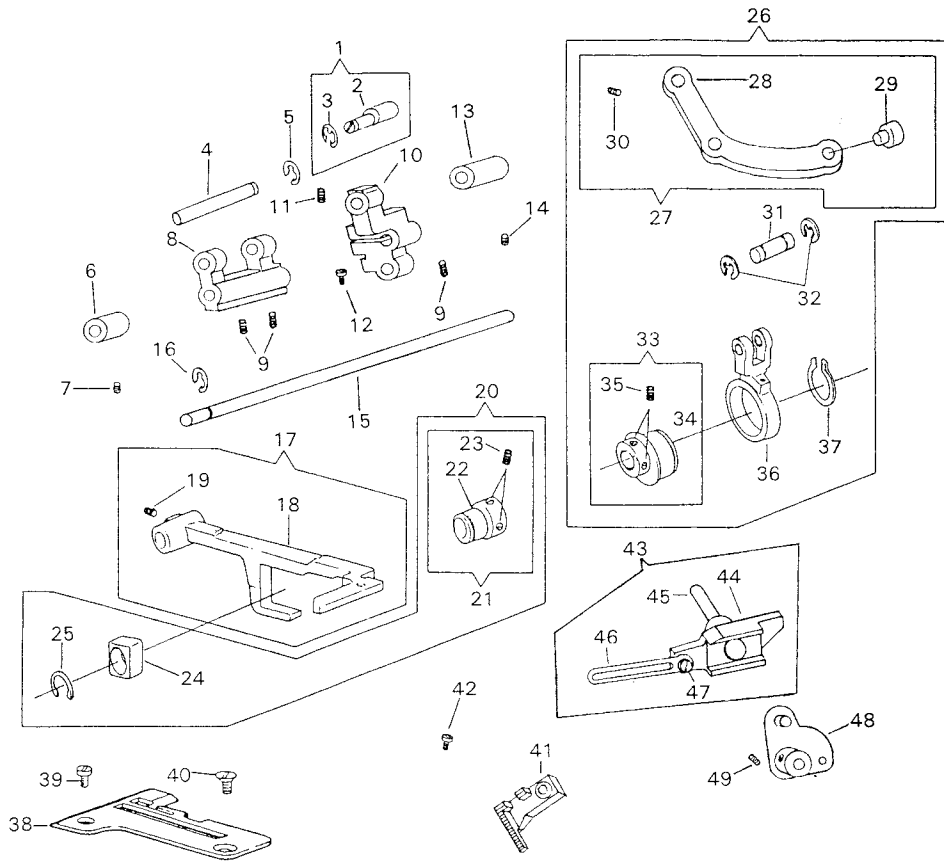

KEY	DESCRIPTION	KEY	DESCRIPTION
1	Feed crank eccentric pin complete	40	Needle plate set screw
2	Feed crank eccentric pin	41	Auxiliary feed dog
3	Snap ring E-5	42	Auxiliary feed dog set screw
4	Feed crank pin	43	Feed regulator complete
5	Snap ring E-6	44	Feed regulator
6	SB bushing	45	Feed regulator set pin
7	Hexagon socket screw 5 x 5	46	Feed regulator connecting plate
8	Feed crank SB	47	Feed regulator hinge screw
9	Hexagon socket screw 4 x 4	48	Feed regulator adjusting plate
10	Feed crank SC	49	Hexagon socket screw 4 x 4
11	Hexagon socket screw 5 x 5		
12	Pan head hexagon socket screw 5 x 12		
13	SC bushing		
14	Hexagon socket screw 5 x 5		
15	Feed crank shaft		
16	Snap ring E-5		
17	Feed bar complete		
18	Feed bar		
19	Hexagon socket screw 5 x 5		
20	Feed lifting cam unit		
21	Feed lifting cam complete		
22	Feed lifting cam		
23	Hexagon socket screw 4 x 4		
24	Feed lifting cam slide block		
25	Retaining ring-14		
26	Feed regulator crank rod unit		
27	Feed regulator crank rod complete		
28	Feed regulator crank rod		
29	Rivet		
30	Hexagon socket screw 4 x 4		
31	Feed crank rod pin		
32	Snap ring E-4		
33	Feed cam complete		
34	Feed cam		
35	Hexagon socket screw 4 x 4		
36	Feed crank rod		
37	Feed cam retaining ring		
38	Needle plate		
39	Needle plate position screw		

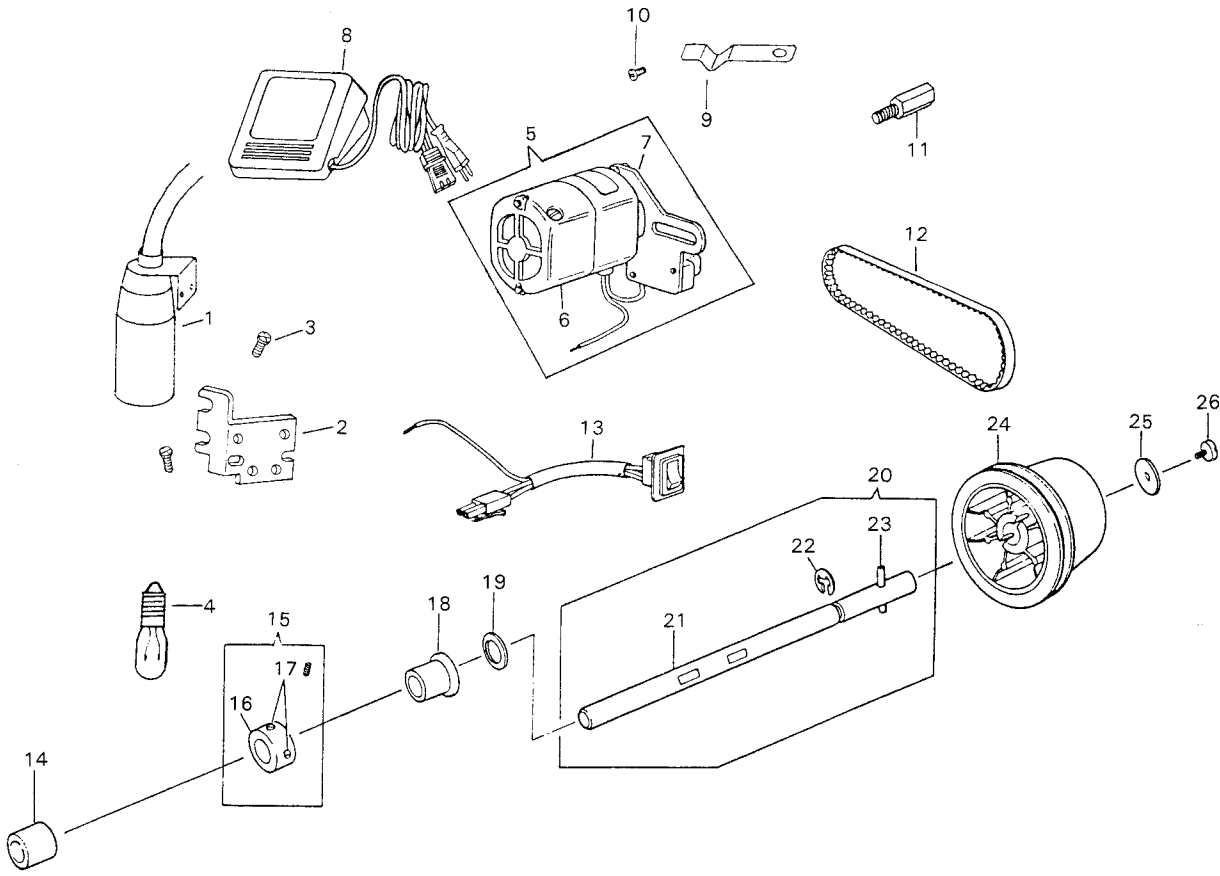

KEY	DESCRIPTION	KEY	DESCRIPTION
1	Lighting set		
2	Lamp socket plate		
3	+ - pan head screw 3 x 5		
4	Bulb		
5	Motor unit		
6	motor		
7	Motor bracket		
8	Foot controller		
9	Spring plate		
10	+ - binding head screw 4 x 6		
11	Motor bracket clamping screw		
12	Belt		
13	Switch		
14	Rotating shaft rear bushing		
15	Rotating shaft collar complete		
16	Rotating shaft collar		
17	Hexagon socket screw 4 x 4		
18	Rotating shaft front bushing		
19	Rotating shaft thrust washer		
20	Rotating shaft complete		
21	Rotating shaft		
22	Snap ring E-9		
23	Spring pin 4 x 20		
24	Balance wheel		
25	Set washer		
26	Washer screw 4 x 10		

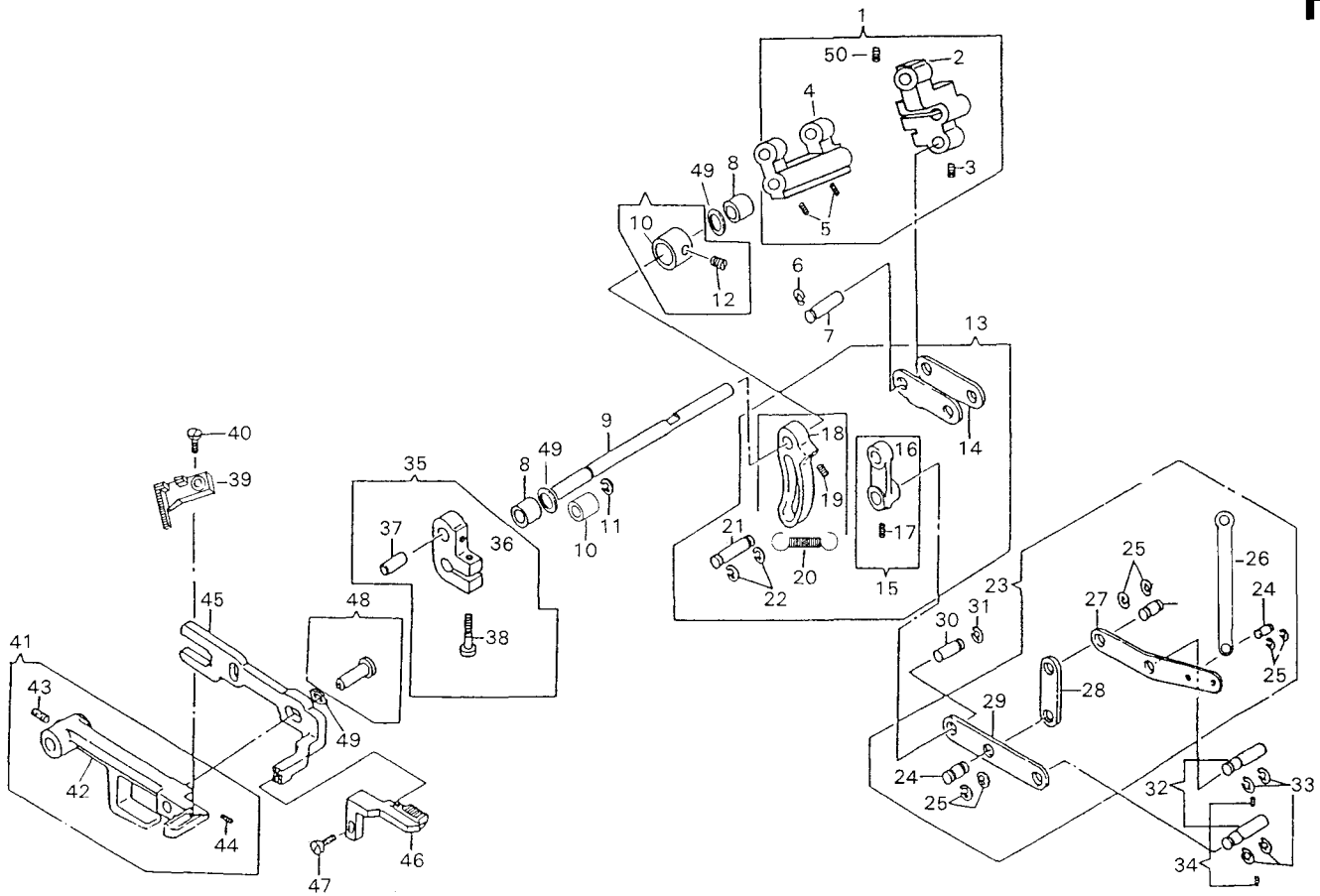

KEY	DESCRIPTION	KEY	DESCRIPTION
1	Feed crank complete	40	Main feed dog set screw
2	Feed crank SC	41	Main feed bar complete
3	Hexagon socket screw 4 x 4	42	Main feed bar
4	Feed crank SB	43	Hexagon socket screw 5 x 5
5	Hexagon socket screw 4 x 4	44	Hexagon socket screw 4 x 4
6	Snap ring E-4	45	Auxiliary feed bar
7	Differential feed crank stud	46	Auxiliary feed dog
8	Differential feed shaft bushing	47	Auxiliary feed dog set screw
9	Differential feed shaft	48	Auxiliary feed bar guide pin
10	Differential feed shaft collar	49	Thrust washer 7.3x0.25x12
11	Snap ring E-6	50	Hexagon socket screw 4 x 4
12	Hexagon socket screw 9/64 x 6		
13	Differential feed crank rod complete		
14	Differential feed crank rod		
15	Differential feed adjusting lever arm complete		
16	Differential feed adjusting lever arm		
17	Hexagon socket screw 4 x 4		
18	Differential feed adjusting arm		
19	Hexagon socket screw 4 x 4		
20	Differential feed adjusting arm spring		
21	Differential feed crank rod stud		
22	Snap ring E-4		
23	Differential feed adjusting lever complete		
24	Differential feed adjusting lever pin		
25	Snap ring E-4		
26	Differential feed safety plate		
27	Differential feed adjusting lever (upper)		
28	Differential feed adjusting lever link		
29	Differential feed adjusting lever (lower)		
30	Differential feed adjusting lever arm pin		
31	Snap ring E-4		
32	Differential feed adjusting lever stud		
33	Snap ring E-4		
34	Hexagon socket screw 4 x 4		
35	Differential feed arm complete		
36	Differential feed arm		
37	Auxiliary feed bar driving pin		
38	Pan head hexagon socket screw 5 x 12		
39	Main feed dog		