

Since 1898
CONSEW®

Model
2206RB-14-7DD



PARTS BOOK
AND
INSTRUCTION MANUAL

Revised 2020

CONSEW USA

目录 CONTENTS

使用说明 INSTRUCTION MANUAL

1、 机器简介 BRIEF INTRODUCTION OF THE MACHINE	1
2、 主要技术规格 MAIN TECHNOLOGY SPECIFICATION	1
3、 安装油盘 INSTALLATION OF THE OIL TRAY	1
4、 安装机头 INSTALLATION OF THE HEAD	2
5、 安装膝控装置 INSTALLATION OF KNEE CONTROL DEVICE	2
6、 调整膝控装置 ADJUST KNEE CONTROL DEVICE	3
7、 润滑 LUBRICATION	3
8、 试车 RUN-IN OPERATION	4
9、 安装机针 INSTALLATION OF THE NEEDLE	5
10、 装卸梭芯套 SETTING THE BOBBIN CASE.....	5
11、 绕取梭芯套 WINDING THE BOBBIN THREAD	5
12、 穿底线 BOTTOM THREAD	6
13、 穿面线 UPPER THREAD	6
14、 调节针距 ADJUSTING THE STITCH LENGTH	7
15、 缝纫及倒缝 STITCHING AND REVERSE STITCHING	7
16、 调节线的张力 ADJUSTING THE THRESD TENSION	8
17、 调节压脚压力 ADJUSTING THE PRESSURE OF THE PRESSER FOOT	8
18、 调节剪线后线头的长度 ADJUSTING THE LENGTH OF THE THREAD END	9
19、 调节挑线簧 ADJUSTING THE TAKE-UP SPRING	9
20、 调节机壳线勾 ADJUSTING THE PRESSER FOOT HEIGHT	10
21、 调节压脚高度 ADJUSTING THE PRESSER FOOT HEIGHT	10
22、 调节送布牙高度 ADJUSTING THE DOG FEED HEIGHT	10
23、 调节送布牙的角度 ADJUSTING THE DOG FEED ANGLE	11
24、 调节倒顺缝针距误差 ADJUSTING THE STITCH AND REVERSE STITCH LENGTH ERROR	11
25、 调节松线器的挺线 ADJUSTING THE LOOSEN THREAD DEVICE OF THE TENSION DISCS	11
26、 调节机针与送布机构同步 ADJUSTING SYNCHRONIZATION OF THE NEEDLE AND FEED DOG DEVICE.....	12
27、 调节旋梭油量 HOOK LUBRICATON ADJUSTMENT	12
28、 调整针杆高度与旋梭同步 ADJUSTING SYNCHRONIZATION OF THE NEEDLE BAR HEIGHT AND HOOK.....	13
29、 调节油泵供油 ADJUSTING THE OIL PUMP LUBRICATION	13
30、 上送料机构的调节 ADJUSTING THE TOP-FEEDING MACHNISM	14
31、 压脚交叉提升机构的调节 ADJUSTING WALKING FOOT AND PRESSURE FOOT	14
32、 摆压脚、小压脚总提升量的调节 ADJUSTING THE LIFTING AMOUT OF THE FOOT	15
33、 摆压脚、小压脚前后方向间隙的调节 ADJUSTING THE CLEARANCE BETWEEN THE FOOT	15
34、 剪线装置的调整 ADJUSTING THE THREAD TRIMMER DEVICE	16~17
35、 清扫 CLEANING	18

目录 CONTENTS

零件手册 PARTS BOOK

A. 机壳部分 MACHINE COVER ASM	19
B. 针杆、挑线部件/NEEDLE BAR AND THREAD TAKE-UP MECHANISM	23
C. 送料部件/ FEED MECHANISM COMPONENTS	27
D. 上送料部件 (9302 专用) /FEED MECHANISM(9302 SPECIAL-PURPOSE)	31
E. 压脚部件 PRESSER FOOT ASM	35
F. 旋梭部件 ROTARY HOOK MECHANISM	37
G. 剪线部件 THREAD TRIMMER ASM	39
H. 供油润滑部件 LUBRICATION	43
I. 倒缝部件 REVERSE FEED COMPONENTS	45
J. 倒缝部件 REVERSE FEED COMPONENTS	47
K. 倒缝部件 REVERSE FEED COMPONENTS	47
L. 附件 ACCESSORIES	49

1. 机器介绍/

BRIEF INTRODUCTION OF THE MACHINE

智能一体型电脑上下复合送料厚料自动剪线平缝机采用连杆式送料、连杆挑线机构、旋梭勾线、形成301线迹。本机采用油泵自动润滑，运转轻滑、噪音低、震动小，特别适用于缝制皮革、帆布、厚重装饰布、织带类织物，如箱包、汽车座垫、帐篷、沙发等。

电脑控制的剪线、定针数、定针位功能，准确可靠。

Direct drive heavy duty computer controlled top and bottom feed auto trimmer lockstitch machine with single straight needle. It adopts link take-up to feed, link thread take-up structure, rotating hook to form stitch 301. The machine adopts the auto-lubrication oil pump. Free and smooth operation, low noise, little vibration, applied to sewing leather, canvas, heavy duty decoration, ribbon type fabric, such as bag, tents, sofa etc.

It is precise with functions of computer controlled thread trimmer, needle stitch count and positioned.

2. 主要技术规格

MAIN TECHNOLOGY SPECIFICATION

缝料/ MATERIAL	中厚料 MIDDLE AND HEAVY MATERIAL	
最高转速/ THE HIGHEST S.P.M	2000r/min	
最大针距 THE BIGGEST STITCH LENGTH	8mm	
针杆行程/ NEEDLE BAR STROKE	37mm	
采用机针/ NEEDLE TYPE	DP ×17 18#-23#	
压脚提升高度 PRESSER FOOT LIFT HEIGHT	手控 HAND CONTROL	6mm
	膝控 KNEE CONTROL	13mm
采用旋梭 HOOK TYPE	自动润滑大旋梭 AUTO-LUBRICATION BIG HOOK	
供油方式 LUBRICATION TYPE	全自动供油 AUTO-LUBRICATION	
电机功率/ MOTOR POWER	750W	

3. 安装油盘 (图 1)

INSTALLATION OF THE OIL TRAY (FIG1)

1. 将机头防震块② (两) 插进油盘①前方的角内。
 2. 将机头防震块③ (两) 插进油盘①后方的角内。
 3. 水平地将油盘④嵌在台板的框孔内。
 4. 将两个机壳铰链套⑤放入台板的凹槽内。
1. Insert the anti-vibration gasket② (two) into front angle of the oil tray①.
 2. Insert the anti-vibration gasket③ (two) into behind angle of the oil tray①.
 3. Insert the oil tray④ into the table groove horizontally.
 4. Put the two cover chain bushes⑤ into the table groove.

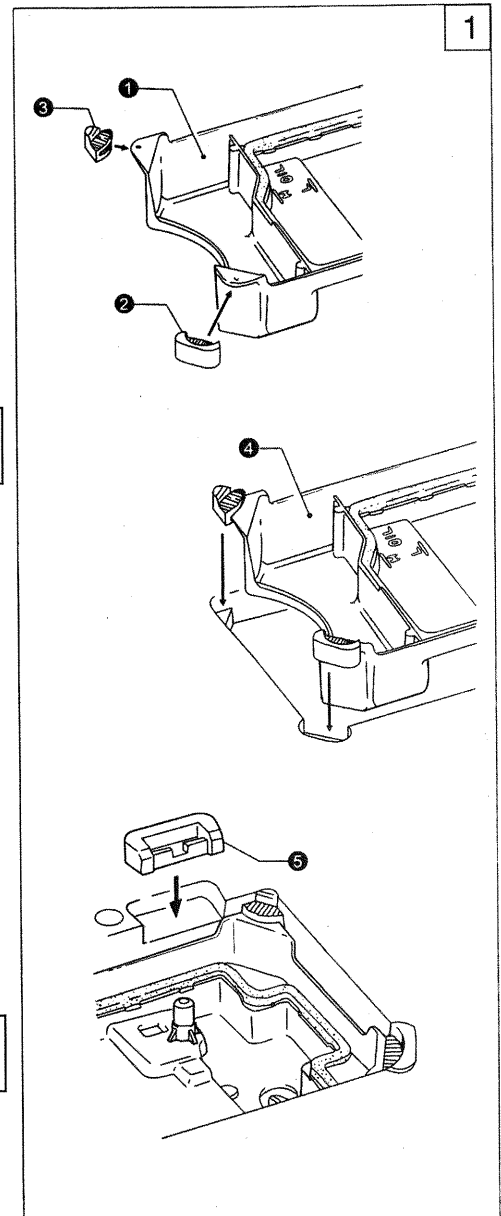

4. 安装机头 (图 2) /INSTALLATION OF THE HEAD(FIG 2)

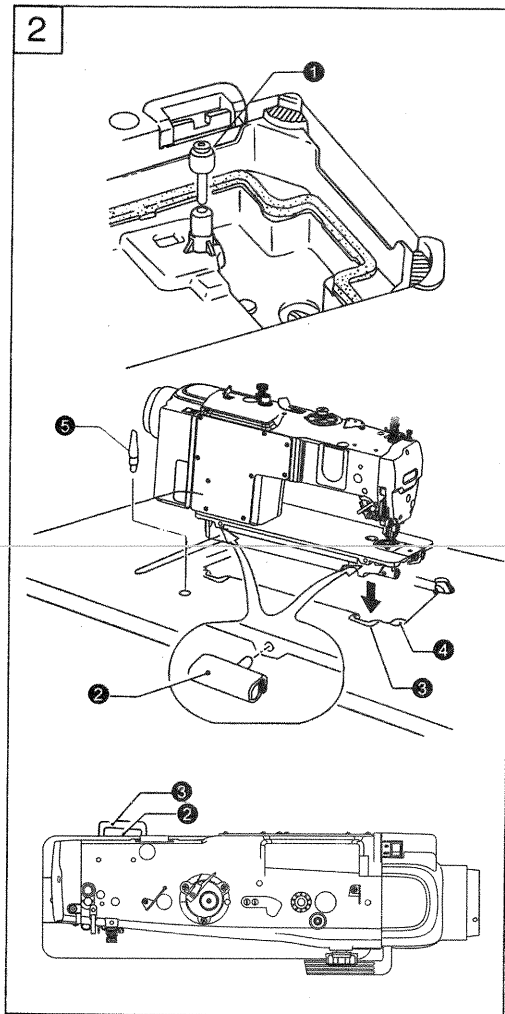

1. 插入膝控提升顶杆①。
2. 将两个机壳铰链②插入机头平板的两孔内。
3. 将机头上的铰链勾住台板上的铰链套, 平稳地将机头放入台板的框孔中。
4. 将机头撑杆⑤插入孔中。

注意:

确保机头撑杆插入孔中。如撑杆未插到最低位置, 放入机头时, 机头将发生倾倒, 这样比较危险。

1. Insert knee control to lift the top bar①.
2. Put the two cover chains② into the two table holes.
3. The chains hookup the bushes on the table. Put the head into the table groove stably.
4. Insert the head support bar⑤ into the hole.

Remarks:

Make sure to insert the head support bar into the hole. Suppose the support bar doesn't reach the lowest place, it will be dangerous when put the machine. And the machine may topple and fall.

5. 安装膝控装置 (图 3) /INSTALLATION OF THE KNEE CONTROL DEVICE (FIG3)

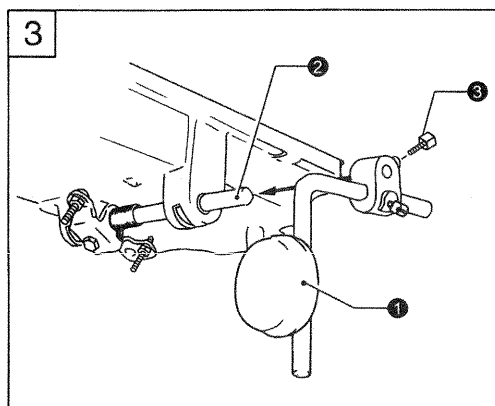

将膝控碰块①, 弯杆及接头插入铰链轴②中, 稍微拧紧螺钉③。

Insert the knee control block①, bend bar and joint into the chains②, then tighten the screws③ lightly.

6. 调整膝控装置 (图 4) /ADJUST KNEE CONTROL DEVICE (FIG4)

1. 转动压脚提升扳手①将压脚②完全放下。
2. 松开螺母③。
3. 拧紧螺钉⑥调节膝控限位架，使之转动 2mm。
4. 拧紧螺母③，松开螺母⑦。
5. 拧动螺钉⑧，使该螺钉的末端至膝控限位架之间的长度达到 8mm。
6. 通过转动螺钉⑧并操作膝控碰块，可以使压脚底面至针板的距离在 13mm 之内得到调整。
7. 调节完成后，拧紧螺母⑦。

1. Turn the presser foot lift spanner① to let the presser foot① down totally.
2. Release the screw③.
3. Tighten the screw⑥ and adjust the knee control limited frame, make it turn 2mm.
4. Tighten the screw③. Release the screw⑦.
5. Turn the screw⑧, and make the distance between the end of the screw and the limited frame is 8 mm.
6. By turning the screw⑧ and operating the knee control block, it can adjust the distance between bottom of the presser foot and needle plate within 13 mm.
7. Finish the adjustment, than tighten the screw⑦.

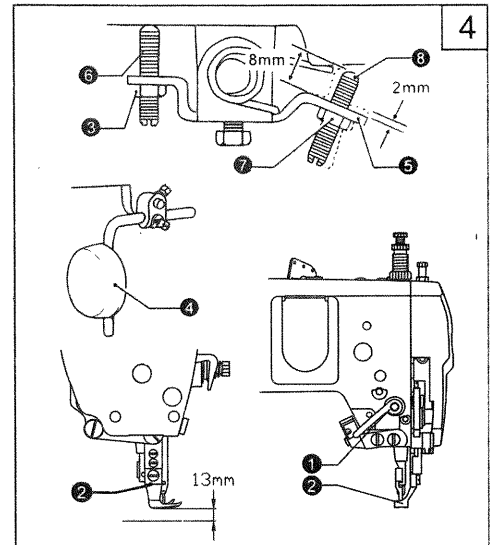

7. 润滑 (图 5) /LUBRICATION (FIG 5)

1. 油量:

油量必须按油盘内标记加注，图中标记 (A) 是油量最高位，(B) 是油量最低位。注意油量不得低于标记 (B)，否则缝纫机各部位就会出现进油停止，造成发热咬死等情况。

2. 加油:

必须使用 18#高速缝纫机油，运转前油量加至标记 (A)。

3. 换油:

(1). 旋下放油螺钉(C),排净废油。

(2). 扫清油盘污尘，旋紧放油螺钉 (C)，加注新油。

1. Oil amount:

Oil amount must be oiled according to the mark of drip pan. Mark (A) is the highest situation. Mark(B) is the lowest situation. Note that oil amount couldn't be lower than mark (B). Otherwise all parts of machine will appear heat and dead point for not gaining oil.

2. Oiling:

Always use only NO.18 special machine oil for high speed sewing. Be sure to replenish oil to line (A) before starting operation.

3. Replacing oil:

(1). To replace oil remove screw(C) to drain oil after completely draining off oil.

(2). To clean the oil tray and to securely tighten screw (C) then to fill the tray with fresh oil.

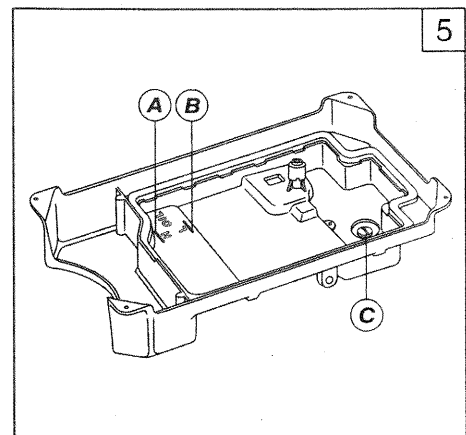

8. 试车 (图 6) / RUN-IN OPERATION (FIG 6)

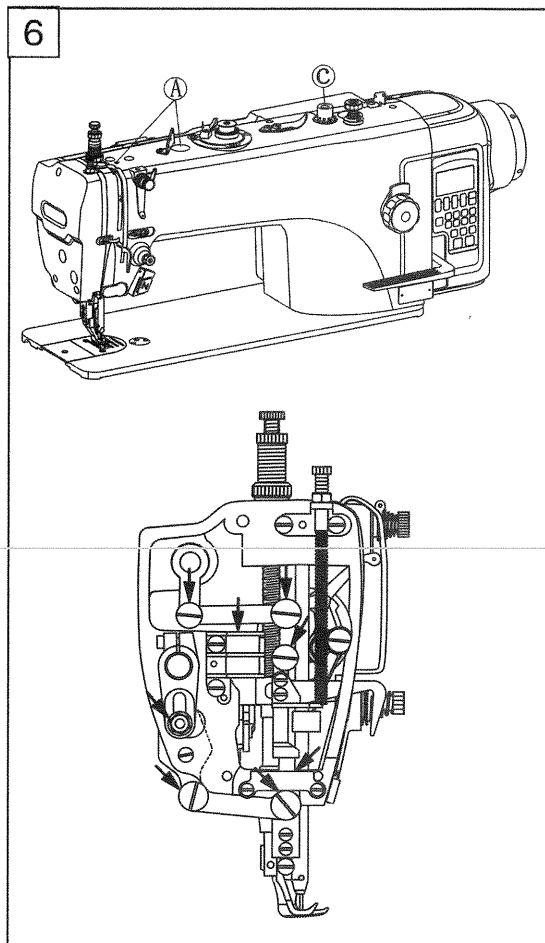

新机器在开始使用和长期搁置重新使用时,先卸下机头上部的橡胶塞(A)和面板,按图示的位置充分加油,然后装上面板,抬起压脚进行低速运转1000~1500针/分,并观察油窗(C)的喷油情况,润滑正常后,仍须保持低速30分钟的运转试验,以后逐步提高缝纫速度;经过一个月左右的使用,使机器充分磨合。然后根据工作的性质再提高到一定缝速。

At the beginning of using the new machine or shelved for a long time, first to unload the upper rubber plug (A) and panel. According to the position of the graphic refueling fully, and then put panel, lift the presser foot and run the machine with for low speed(1000-1500/min), and watch the injection situation of oil window (C). After normal lubrication, also needs to remain 30 minutes at low speed running test, then gradually increase sewing speed. After about a month of using, the machine has fully run, then according to the nature of the work to increase the speed of a certain gap.

9. 安装机针 (图 7) / INSTALLATION OF THE NEEDLE (FIG7)

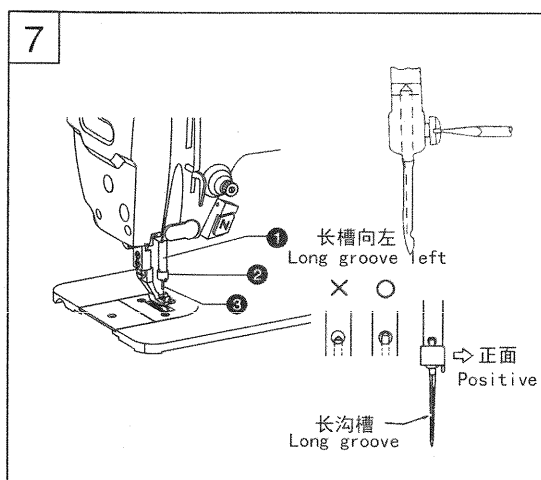

1. 转动上轮使机针上升至最高位置。
2. 旋松夹针螺钉②。
3. 将机针③直线插入到底(碰到针杆孔的底部为止),确保长槽向左,然后拧紧螺钉②。

1. Turn the upper wheel and make it at the top place.
2. Loosen the screw②.
3. Insert the needle③ into the bottom (till touch the bottom), and make sure the long groove left, than tighten the screw②.

10. 装卸梭芯套 (图 8) / SETTING THE BOBBIN CASE (FIG8)

1. 装梭芯套的时候, 机针应该在最高位置。先拉开梭门盖①, 之后把梭芯套放入旋梭中。放入时请注意梭芯套上的定位板是否已经和旋梭心轴上的定位槽想扣合。

2. 卸梭芯套时, 必须将梭门套向外扳开并且扳足, 之后捏着扳开的梭门盖徐徐地取下梭芯套, 如此才能使梭芯套钩住梭芯, 不让梭芯脱落。

1. The needle should at the top place when install the bobbin case. First pull the bobbin cover①, than put the bobbin core into the hook. Please make sure the batter board match with the locating slot when you put the bobbin core.

2. Please make sure to open the bobbin door when you replace the bobbin core. Then hold the bobbin door and replace the bobbin core slowly. So that can make the bobbin bush tight the bobbin core. And will not drop.

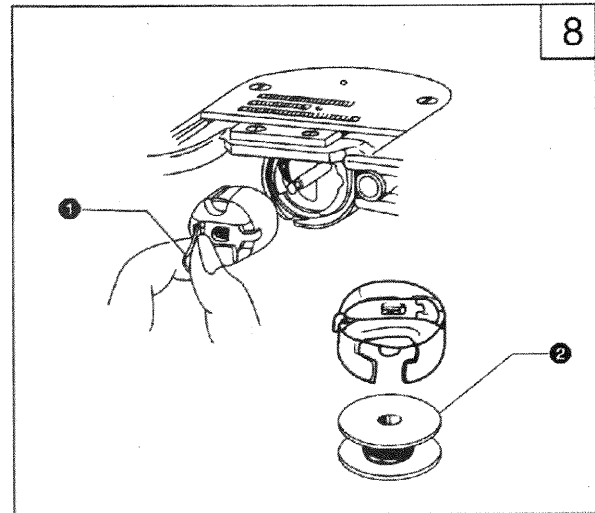

11. 绕取梭芯线 (图 9) / WINDING THE BOBBIN THREAD (FIG9)

1. 打开电源。将梭芯插入绕线器②的底部。
2. 根据箭头所示的方向, 先将线在梭芯上绕几圈。
3. 扳动绕线摆杆③。将压脚抬起来。
4. 踩下踏板, 便开始自动绕底线了。
5. 当梭芯绕满后, 绕线摆杆③便会自动复位。
- ★ 如果梭芯线排列不齐, 可以通过松开过线架螺钉④及移动绕线摆杆③的位置进行调节。
- ★ 绕线量由满线跳板上的满线度调节螺钉⑥加以调节。

注意:

适当的绕线量为平行绕线至梭芯外径的 80%。

1. Turn on the power. Insert the bobbin core into the bottom of bobbin winder②.
2. According to the arrow direction. Please winder the thread on the bobbin core for several circles.
3. Turn the winder spanner③. Lift the presser foot.
4. Push the pedal down, and it will winder the thread automatically.
5. The winder spanner③ will recover automatically when the bobbin thread is full.
- ★ If the bobbin thread in misalignments. You can loosen the screw④ and move the winder spanner③ please to adjust.
- ★ The winder thread amount can be adjusted by the screw⑥.

Remarks: The suitable winder thread amount is 80% around the bobbin core horizontally.

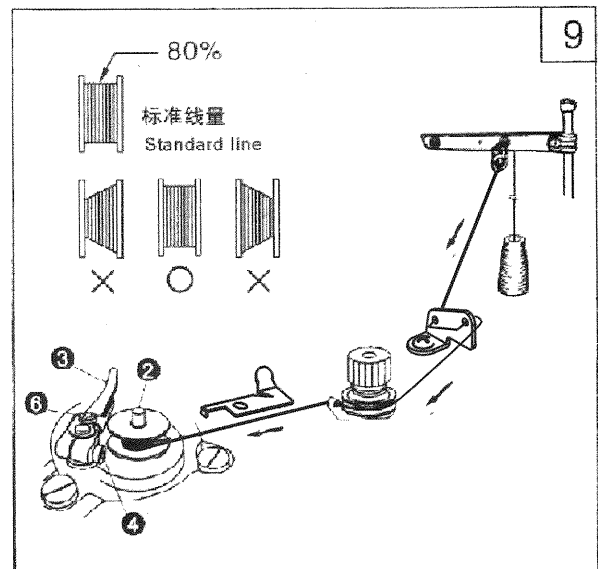

12. 穿底线 (图 10) / THREADING BOTTOM THREAD (Fig 10)

1. 转动上轮使机针上升至最高位置。
2. 梭芯线应为右捻线, 然后将梭芯装入梭芯套中。
3. 捏着线头使其嵌入梭芯套开口槽①中, 经过橡皮簧②顶端叉口③中间拉出线头。
4. 当牵引线时, 梭芯应是顺时针转动。
5. 扳开梭门盖④, 将梭芯套装入旋梭中 (放入时请注意梭芯套上的定位板是否已经和旋梭芯轴上的定位槽相扣合。)

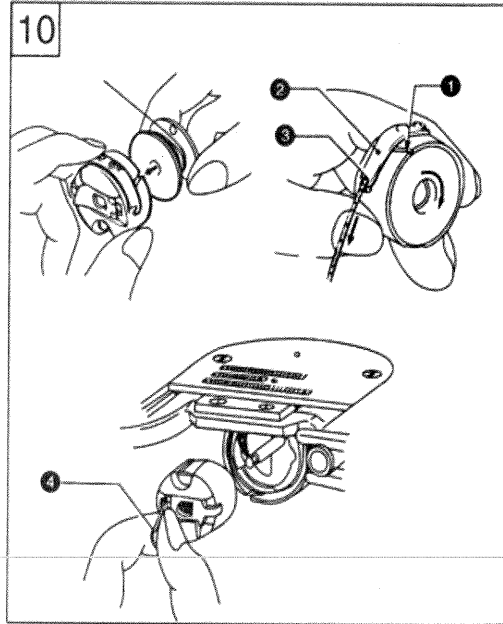

1. Turn the hand wheel till the needle up to the highest position.

2. The bobbin thread should be right twisting. Then put the bobbin into the bobbin case.

3. Holding thread end embed the bobbin in the set of open slot①, after the top of the spindle skin② spring fork intermediate outlet head③.

4. The bobbin should be clockwise when the bobbin thread is draw up.

5. To pry the bobbin covered④ put the bobbin sets into the hook (add note when the bobbin case the positioning plate is on the positioning groove on the shaft and bobbin core is consistent).

5. To pry the bobbin covered④ put the bobbin sets into the hook (add note when the bobbin case the positioning plate is on the positioning groove on the shaft and bobbin core is consistent).

13. 穿面线 (图 11) / THREADING UPPER THREAD (Fig 11)

在穿面线之前请让挑线杆上升至最高位置, 这样便于穿线并可防止开始缝纫时发生面线从针孔中脱落。

Before wear line please let take-up lever rose to the highest position, so easy to thread and can prevent the start sewing line fall off from the pinhole.

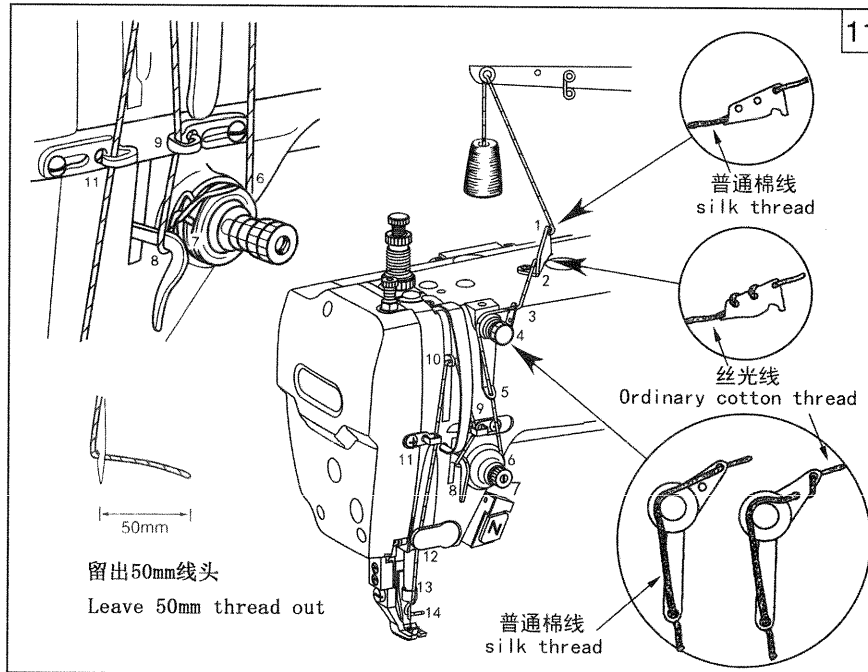

14. 调节针距 (图 12) / ADJUSTING THE STITCH LENGTH (FIG12)

按下针距按键②，左右转动针距标盘①，将针距标盘①上的数字对准针距按键②上的竖线标记。

- ★ 数字越大，相应的针距越大。
- ★ 当针距标盘①上的数字从大向小方向转动时，将倒缝扳手③向下压至一半位置时，转动时更加轻松一些。

Push the button② of needle gauge, rotate the dial①. Make sure the number② on the dial① align to the vertical line of the button.

- ★ The greater the number, the bigger the stitch length.
- ★ Please put the reverse spanner③ down at the half place when the NO. on the dial① turns from big to small. It will be much easier.

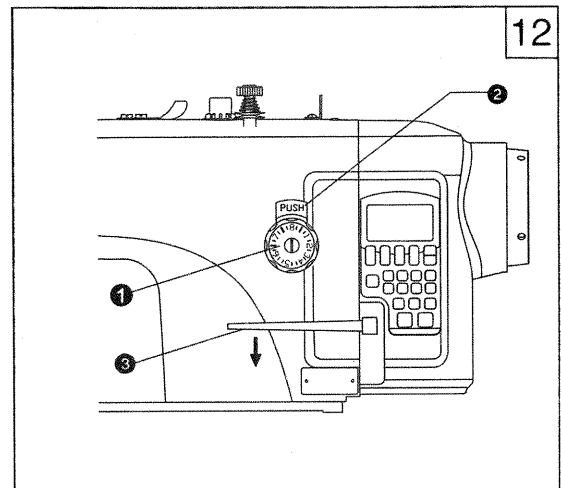

15. 缝纫及倒缝 (图 13) / STITCHING AND REVERSE STITCHING (FIG13)

1. 按下电源开关。
2. 踩下踏板，缝制开始。

正常缝制过程中，按下倒缝扳手①或是按下自动倒缝开关②，便开始反向送料，放送时，则恢复正常送料。

1. Press the power button.
2. Push the pedal down, and begin to sew.

During the process of normal sewing, when you press the reverse spanner① or press the auto-reverse button②, the machine will begin to back stitch. When you loose it, the machine will feed normally.

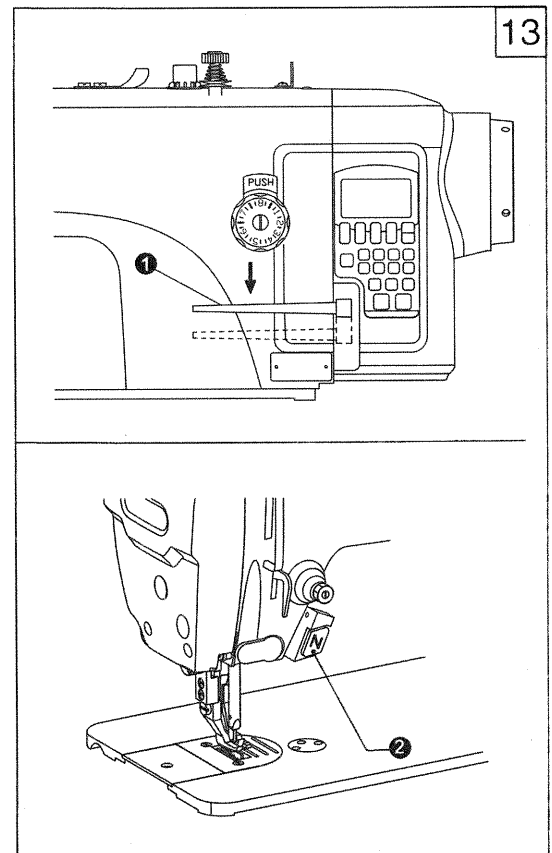

16. 调节线的张力 (图 14) /ADJUST THE THREAD TENSION(Pic14)

正常线迹

14



← 面线 /Upper thread
← 底线 /Bottom thread



*当面线张力太弱时出现的线迹
*The stitch which the upper thread tension is too weak

*增大面线张力
Strengthen the upper thread tension
*减弱底线张力
Weaken the bottom thread tension



*当面线张力太强时出现的线迹
*The stitch which the upper thread tension is too strong

*减弱面线张力
Weaken the upper thread tension
*增大底线张力
Strengthen the bottom thread tension

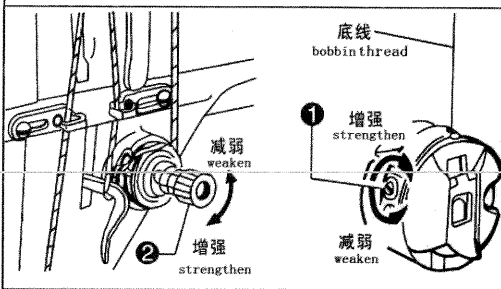

<底线张力><Bottom thread tension>

通过转动梭皮螺钉①调节底线的张力，一半为捏住线头吊起梭芯套，梭芯套能够缓慢地自由落下就可使用了。

Adjust the bobbin thread tension by turning screw ①. Pinch the thread lift the bobbin case. It can use when bobbin case fall freely and slowly .

<面线张力><Upper thread tension>

将底线张力调节完后，再调节面线张力更好，会出现正常的线迹。

Finished to adjust the bobbin thread tension, then adjust the upper thread tension ,will appear the normal stitch.

1. 放下压脚。/Put down presser foot .

2. 调节夹线器螺母②。/Adjust thread tension nut ② .

17. 调节压脚压力 (图 15) /ADJUST THE PRESSURE OF PRESSER FOOT(PIC15)

<调节压脚的压力>

1. 旋松调压螺钉锁紧螺母①。

2. 转动调压螺钉②来调节压脚压力，在压力不够的情况下，可以转动螺钉②来增加压力。

★在保证缝料不打滑的情况下，压脚的压力尽可能的弱一些。

3. 拧紧调压螺钉锁紧螺母①。

1. Loosen the presser spring regulator and lock nut①.

2. Turning the presser spring regulator② to adjust the pressure of presser foot .Turning presser spring regulator② to pressure under the pressure is not enough.

★In ensuring sewing material does not slip, the pressure of the presser foot as much as possible weaker.

3. Tighten the presser spring regulator and lock nut①.

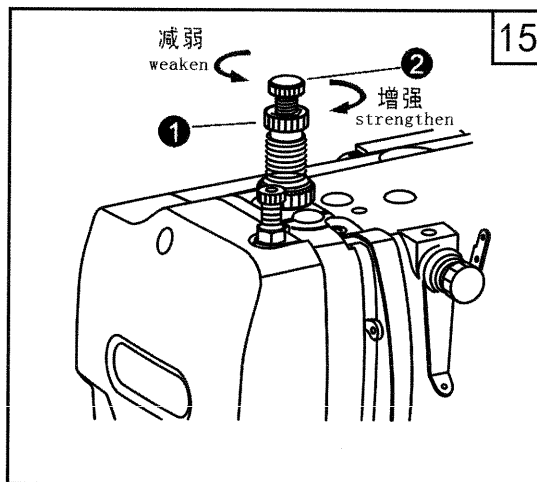

15

18. 调节剪线后线头的长度 (图 16)

ADJUST THE LENGTH OF THE THREAD AFTER TRIMMING (Fig16)

通过转动小夹线螺母①来调节。

- 在剪线的时候, 夹线器松开, 面线只有小夹线器提供的张力。
- 标准面线线头的长度为 40~70mm。
- 如果小夹线螺母①旋紧, 那么面线的线头长度就短。
- 如果小夹线螺母①旋松, 那么面线的线头长度就长。

By turning a small thread clamp nut① to adjust.

- When the shear line, the line is loose, line only small thread clamp device provided by the tension.
- The length of the standard surface lines head for 40-70 mm.
- If small clip line nut① and tighten the thread of the line length is short.
- If the thread clamp nut① to relax, the thread of the line length is long.

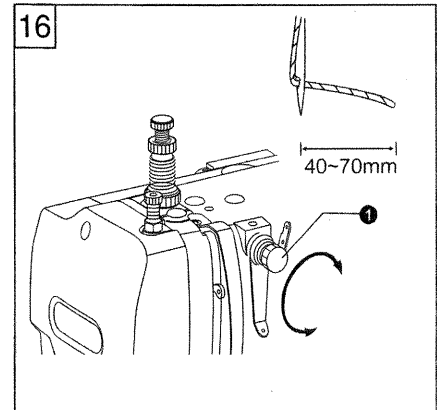

19. 调节挑线簧 (图 17) /ADJUST THREAD TAKE-UP SPRING (FIG17)

★ 挑线簧的标准位置为: 当压脚②放下时, 大线勾③的上表面至挑线簧①5~8mm。

1. 放下压脚②。 松开固定螺钉④。
2. 转动夹线组件⑤调整夹线簧的位置。
3. 拧紧固定螺钉④。

★ 挑线簧的标准强度为 0.3~0.6N。

4. 将面线拉出夹线器⑤少许, 并用手指按住。
5. 将面线向下拉, 使挑线簧①与大线勾③上表面一致, 这时就测定挑线簧的强度。
6. 用开刀插入夹线螺钉槽⑥中, 通过转动开刀来调节挑线簧①的力度。

注意: 当使用测力器⑦请读取对准红线上的那个数字。

★ Pick wire spring standard mainly as follows: When the presser foot② down, big hook line③ to pick line on the upper surface of the spring① 5~8 mm.

1. Put down the presser foot②. Loosen the set screw④.
2. Turn the clip line components⑤ to adjust the position of the wire spring.
3. Tighten the set screw④.

★ Pick wire spring intensity is 0.3~0.6N.

4. Pull line thread clamp device⑤, a little fingers to hold.
5. Face line down, make pick wire spring① and big line hook③ on the surface, is determined to pick the strength of wire spring.
6. Open to insert thread clamp screw groove⑥, by taking turns to adjust the strength of the wire spring①.

Notice:

When using a force-measuring device aim⑦ please read the number on the red line.

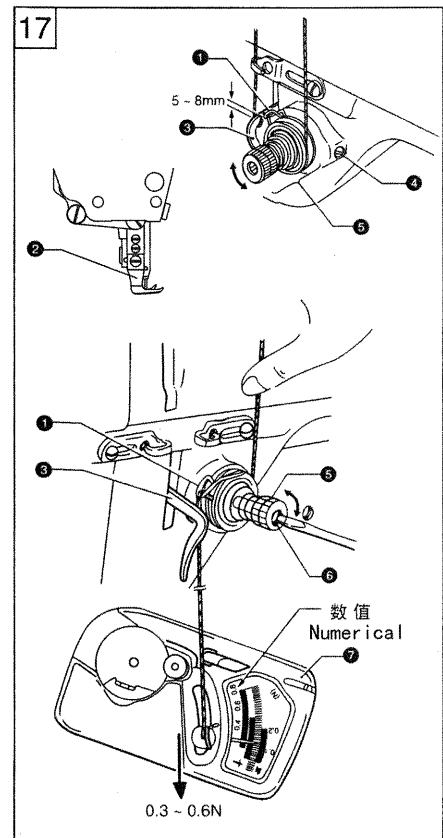

20. 调节机壳线勾 (图 18) /ADJUST THE THREAD HOOK (Fig18)

机壳线勾①的标准位置是螺钉②处于机壳线勾调节范围的中心位置。

通过松开螺钉②，移动机壳线勾来调节位置。

当缝纫厚料时，将机壳线勾向左移（挑线力将增大）。

当缝纫薄料时，将机壳线勾向右移（挑线力将减弱）。

Casing thread① hook screw② is the standard location in chassis line adjusting the center of the range.

By moving to loosen the screw②, the first to adjust the position.

When sewing thick, to check the chassis line moves to the left (line force will push big).

When sewing thin material, to check the chassis line moves to the right (pick line force will be weakened).

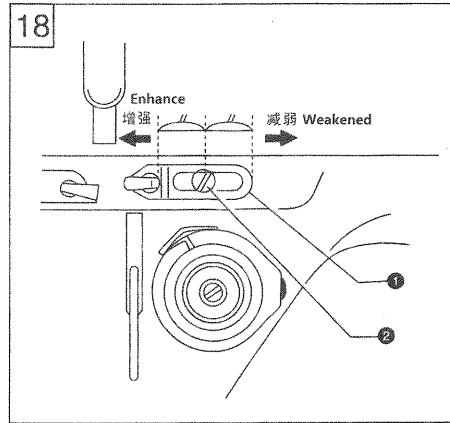

21. 调节压脚高度 (图 19) /ADJUST THE HEIGHT OF PRESS FOOT (Fig19)

当使用压脚扳手②提升压脚①时，压脚①的标准提升高度为 6mm。

1. 松开压脚调节螺钉③，使压紧杆及压脚①上升。

2. 在压脚①下放置 6mm 厚的量块。

3. 松开螺钉④上下调整压脚①高度。

4. 拧紧螺钉④。

When using presser foot wrench②ascension presser foot①, the standard of the presser foot hoisting height is 6 mm.

1. Loosen the presser foot the adjustable screw③ presser bar and presser foot①up.

2. In the presser foot① gauge block of 6 mm thick.

3. To loosen screw height of presser foot ①up and down④.

4. Tighten down the screw④.

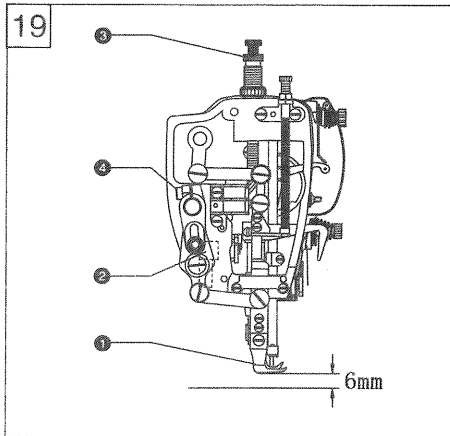

22. 调节送布牙高度 (图 20) /ADJUST THE HEIGHT OF THE FEED DOG (Fig 20)

1. 最大针距时，送布牙①高出针板 1.2mm 为标准。

2. 松开螺钉②转动抬牙叉③的角度，就可调整送布牙齿的高度。

1. Maximum stitch, the largest feed dog① needle plate above the 1.2 MM standard.

2. Loosen the screw② rotation carried the angle of the forks③, feed dog height can be adjusted.

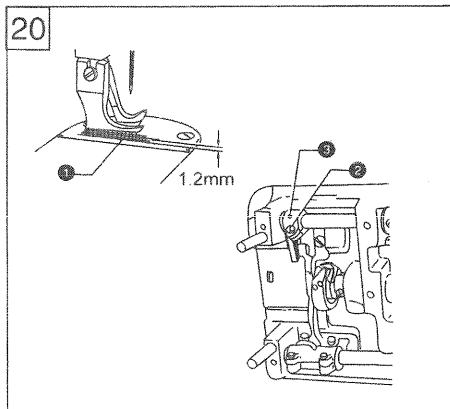

23. 调节送布牙的角度(图 21)/ADJUST THE HEIGHT OF THE FEED DOG (Fig21)

送布牙的标准倾斜角度为:当送布牙高于针板并处于最高位置时, 牙架曲柄偏心轴⑤上的凹点标记处于水平位置。

1. 转动上轮使送布牙浮出针板并处于最高位置。
2. 松开牙架曲柄轴螺钉⑦。
3. 根据送布牙的标准位置, 使凹点标记 90°范围内转动调整。
★ 送布牙前方降低, 可以防止布料起皱(图 A)。
★ 送布牙前方抬高, 可以防止布料跑偏(图 B)。
4. 拧紧牙架曲柄轴螺钉⑦。

送布牙角度调整结束后, 重新调节送布牙的高度是必要的。

Feed dog standard angle is: when the feed dog higher than needle plate and in the highest position. Braces concave point⑤ on the crank eccentric shaft tags in a horizontal position.

1. Turn the wheel make the feed dog to needle plate and in the highest position Loosen.
2. Loosen the braces crank shaft screw⑦.
3. According to the standard of the feed dog angle position. Make the concave point mark 90° rotation adjustment.

- ★ Feed dog in front of the lower. can prevent the fabric wrinkling (picture A).
- ★ Feed dog in front of the drive up, can prevent the cloth running deviation (picture B).
- 4. Tighten braces crank shaft screw⑦.

After the feed dog angle adjustment, to adjust the height of the feed dog is necessary.

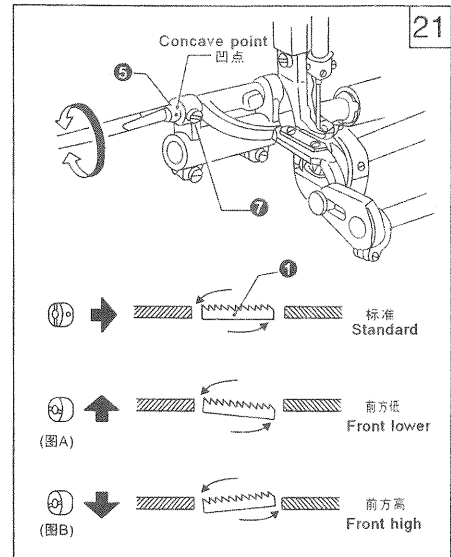

24. 调节倒顺缝针距误差(图 22)/ADJUST THE REVERSING SUTURE NEEDLE DISTANCE (Fig22)

1. 卸下后盖板。松开螺钉①转动针距调节连杆偏心销钉②。

- ★ 顺时针转: 顺缝针距变大, 倒缝针距变小。
 - ★ 逆时针转: 顺缝针距变小, 倒缝针距变大。
2. 拧紧螺钉①。

1. Remove rear cover plate. Loosen screw① transfer stitch length adjustment rod eccentric pin②.

- ★ Turn clockwise: Clockwise stitches change to the large, reverse stitches change to small.
- ★ Anticlockwise turn: Clockwise stitches change to small, reverse stitches change to large.

2. Tighten the screw① .

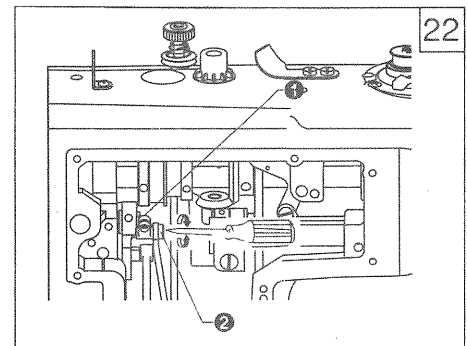

25. 调节松线器的挺线(图 23)/ADJUST THE LOOSEN THREAD TENSION DEVICE (Fig23)

压脚在提升范围内, 夹线器上的夹线板有一个张开期, 挺线的时间可进行调节。调节时, 先卸下机头后侧面的橡皮塞, 用螺丝刀旋松膝控提升杠杆(左)螺钉①, 这时松线凸轮②可以左右移动, 往右移挺线慢, 往左移挺线快。

Presser foot within the scope of the promotion, thread clamp plate on the thread clamp device has an open phase, a line of time can be adjusted. Regulation, to unload the nose back the rubber plug, use a screw driver spiral knee point increase leverage left screw①, loose thread cam② can move around at this moment, the right line is quite slow, quickly move to the left a line.

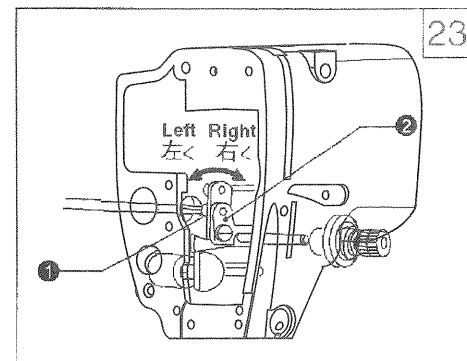

26.调节机针与送布机构同步 (图 24)

ADJUSTING SYNCHRONIZATION OF THE NEEDLE AND FEED DOG DEVICE(Fig24)

标准位置:

当送布牙①从最高位置下降,机针孔中心③应与针板②上表面、送布牙①顶端在同一水平面上。调整可以通过调节送布凸轮和抬牙轮的安裝位置进行。

When feed dog ① from top down, should machine pinhole center ③ and needle ② plate surface, the top of the feed dog ① in the same horizontal plane. Adjustment can be found by adjusting the feed cam and tooth cam installation location.

1. 卸下后盖板。

2. 用左手逆时针转运上轮,以上轴齿轮第二只固定螺钉④为基准,抬牙凸轮的第三只固定螺钉⑤中心,将对齐④中心,稍微向下偏一点。

3. 继续逆时针转动上轮,以抬牙凸轮⑧第二只紧固螺钉⑥为基准,送布凸轮的第三只螺钉⑦中心,将对齐⑥中心,稍微向上偏一点。

4. 若要调整为非标准位置,则先松开抬牙凸轮上三颗螺钉,再根据(A)或(B)所示方向少许转动偏心凸轮⑧。为增加线的张力,则向(A)方向转动。

为避免机针折弯,则向(B)方向转动。

5. 调整结束后,拧紧所有螺钉。

1. Remove the rear cover.

2. On the left hand counterclockwise transfer wheel, axle gear two fixed screws ④ as a benchmark, carry the tooth cam of the third set screw ⑤ center, will align the center ④, a little bit down slant.

3. Continue to counterclockwise rotation, to carry the tooth cam ⑧ second fastening screws ⑥ as a benchmark, only a third of the feed cam fastening screw center ⑦, will align the center ⑥, a slight upward slant.

4. If you want to adjust to non-standard location, loose the three screws on the tooth cam, then turn the eccentric cam ⑧ according to the direction which is shown at (A) or (B). To increase the line tension, to (A) direction of rotation.

To avoid needle bending, is toward (B) direction of rotation.

5. After the adjustment, tighten all bolts.

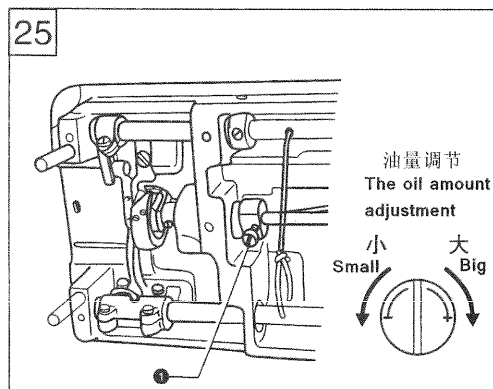
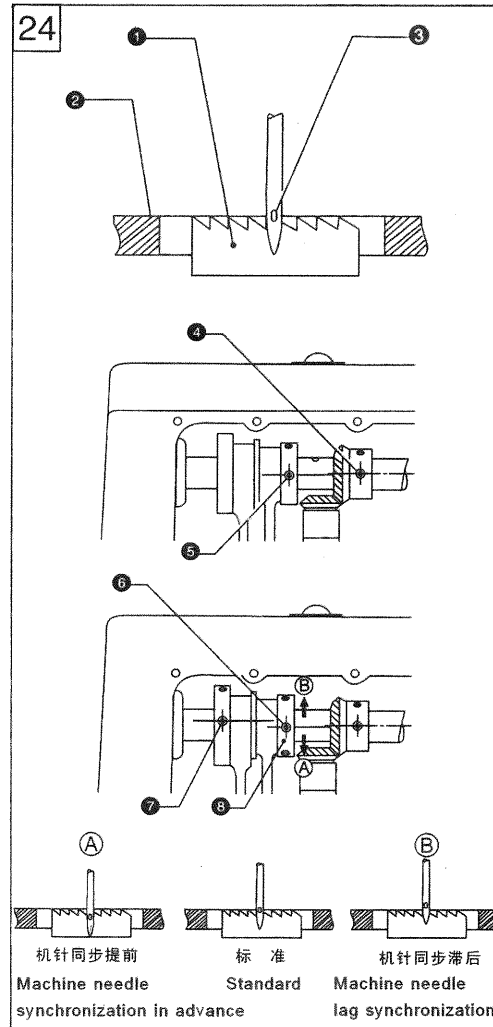

27.调节旋梭油量 (图 25)

ADJUST THE HOOK LUBRICATION(Fig25)

放到机头,转动油量调节螺钉①来调节油量大小。

Put down the machine, turn the fuel control screw ① to adjust oil quantity size.

28.调整针杆高度与旋梭同步 (图 26)

ADJUST THE NEEDLE BAR HEIGHT AND HOOK SYNCHRONOUS (Fig26)

当针杆降至最下位置时, 针杆①最上面的刻线标记应与针杆下套②的下端面一致。

1. 转动上轮, 使针杆降至最下位置;取下橡胶塞③。
2. 松开螺钉④, 然后上下移动针杆①来调节它的位置。
3. 拧紧螺钉④;塞上橡皮塞③。

When the needle bar① have fallen to the bottom position, needle bar① scribed line on the top mark should be consistent with the needle bar② under the next set of end face.

1. Turn the last round, the needle bar to hang down the position; Remove the rubber stopper③.
2. Loosen the screw④, and then move the needle bar up and down to adjust its location.
3. Screw down the screws④; Inserting rubber plug③.

使针杆①从最下位置上升, 当针杆①上数第二条刻线标记 (B) 对准针杆下套②的下端面时 (如图所示), 旋梭的梭尖⑤应对准机针⑥的中心。

1. 转动上轮使针杆①从最低位置上升, 直至上数第二条刻度标记 (B) 对准机针的边沿。

★当针杆上升 2mm 时, 针眼上限与旋梭梭尖之间的距离为 1.3~1.8mm。

2. 松开螺钉⑦, 然后将梭尖对准机针⑥的中心。此时旋梭尖与机针的侧面间隙为 0.05mm。
3. 拧紧螺钉⑦。

Make the needle bar① up from the bottom position , when the needle bar① for the second time line mark on the face, the needle bar② under the set of rotating hooks of spindle tip⑤ should be aimed at the center of the needle⑥.

1. Turn on round the needle bar① rise from the lowest position, until the number the second scribed line marking on the needle bar under the set of edges.

★ When the needle bar up 2 mm, with the distance between the ceiling and spin h. pointed 1.3-1.8 mm.

2. Loosen the screw⑦, then spindle tip aimed at the center of the needle, the spin h. Pointed to the side of the needle clearance is 0.05mm.

3. Tighten the screws⑦.

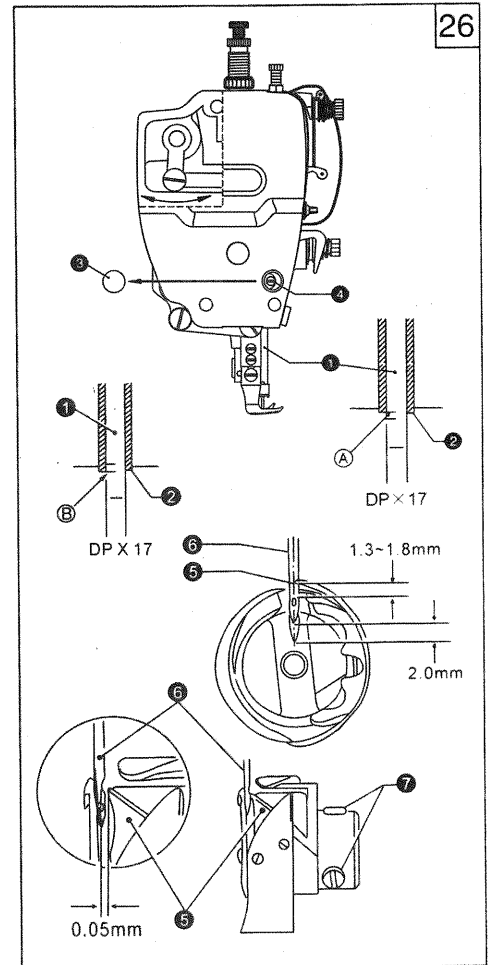

29.调节油泵供油 (图 27)

OIL PUMP ENTERING OIL ADJUSTMENT (Fig 27)

当低速运转时, 观察油窗, 无喷油现象时, 请转动供油调节板①, 将其盖住油孔②。

When it's running at low speed, observe the oil window. If you don't see the oil spraying. Please turn the oil-supplied regulating plate① and cover the oil hole②.

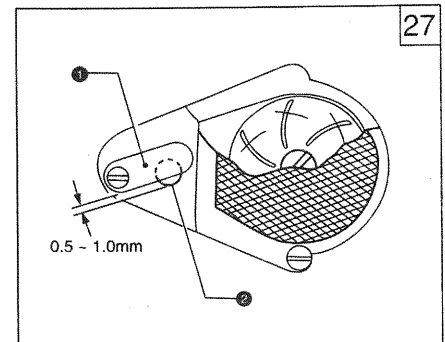

30. 上送料机构的调节 (图 28) / Adjusting the top-feeding mechanism (Fig.28)

上、下同步送料是该产品的重要性能之一。在缝纫过程中, 应根据各种缝料的摩擦系数的不同和缝纫工艺的不同要求, 对上送料机构的摆压脚滑块与摆压脚轴的中心距 (L) 进行调节。

调节方法: 增大中心距 L-上送料量增大。
减少中心距 L-上送料量减少。

对于某些制品的特殊缝纫要求, 如缝件的上层的送料量要求大于 (或小于) 下层的送料量, 也可以根据以上原理在一定范围内调节使用。

The main feature of this machine is top-bottom feed. In practice of sewing, the length (L) between the center of working foot shaft and walking foot sliding assembly should be adjusted according to different fraction ratio of materials and requirements of the workpieces .

Method: The L increase-the top feeding increase.
The L decrease-the top feeding decrease

Some workpiece has the special requirement that top-feeding should be more than the bottom-feeding, which could be realized by the method.

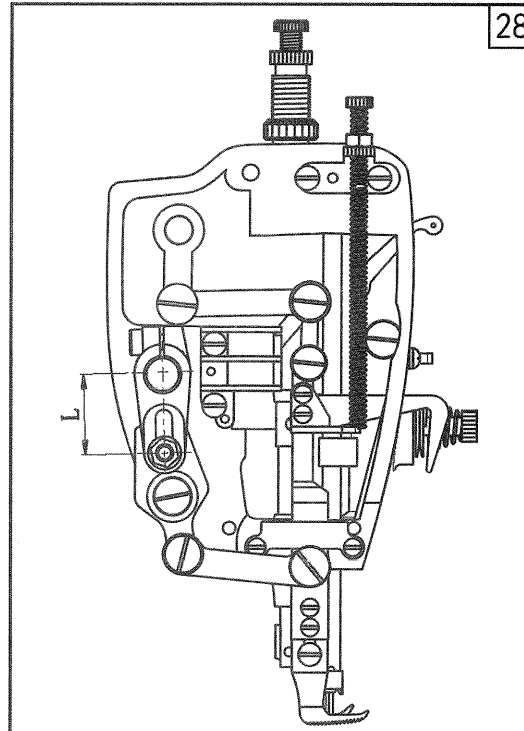

31. 压脚交叉提升机构的调节 (图 29) / Adjusting walking foot and pressure foot (Fig.29)

根据缝料疏松和结实程度的不同, 在缝纫中, 对摆压脚, 小压脚的交叉提升量, 可在一定的范围内进行适当的调节。在一般的中厚料缝纫中, 摆压脚提升量为 5.5mm 之内, 小压脚提升量为 3.5mm 左右。当其他机构不变的情况下, 两压脚提升量之和基本上是一定值。两提升量的变化近似于按反比定律变化。即: 摆压脚的提升量增加, 则小压脚的提升量减少。反之亦然。

调节方法: 旋松偏心轮连杆调节曲柄螺钉 A, 按图示向上转动压脚升降前曲柄, 摆压脚的提升量增大, 反之, 向下转动, 摆压脚的提升量减少。但其调节量有一定的范围限调, 不宜过大。调节后, 将螺钉拧紧, 用手转动上轮, 检查一切正常后方可使用。

The height of walking foot and pressure foot can be adjusted in a certain dimension according to the density of materials. For the mid-heavy materials, the height of walking foot is $\leq 5.5\text{mm}$, and pressure foot $\leq 3.5\text{mm}$. The plus of the two height are definite under the circumstance that the other mechanism keeps unchanged. The relation between the two heights is negative ratio in general sense, when the height of the walking foot increase the height of pressure foot decrease while vice versa. Adjusting method: Loose the screw A on link adjusting crank and turn the crank upward and the height of the walking foot increase; While turn the crank downward, the height decrease. The turning degree of the crank should not be too much. Afterwards, tighten the screw and turn the balance wheel to ensure everything in normal position.

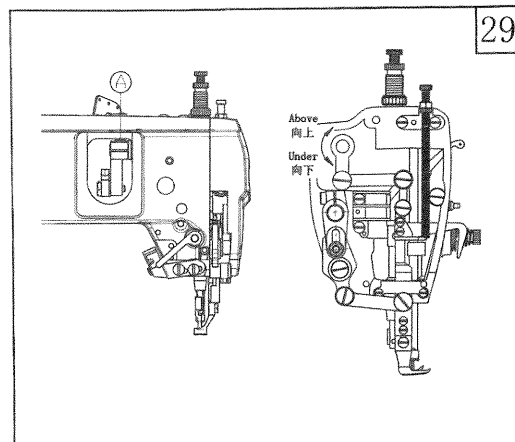

32. 摆压脚、小压脚总提升量的调节 (图 30)

Adjusting the lifting amount of the walking foot and pressure foot(Fig.30)

在缝制过程中,要改变摆压脚、小压脚的提升量,其调节方法是:先将偏心轮连杆螺钉(A)旋松,然后调节该螺钉与压脚升降轴中心距B:如要使摆压脚、小压脚的提升量都增加,则使中心距B调小;反之,则可使提升量都减少。其调节量也有一定的范围,调节幅度不宜过大,调节好后,将螺钉拧紧,慢慢转动上轴,检查有无碰撞现象,一切正常后方可使用。

In practice, in order to adjust the height of walk foot and pressure foot, you can adopt the method: Loose the screw(A) on link adjusting crank and adjust the length between the center of the screw and the presser foot lift shaft. If the length decrease, the lifting amount of the two increase, while vice versa. The adjusting amount is in a certain dimension and should not be too much. Afterwards, tighten the screw and turn the balance wheel to ensure everything in normal condition.

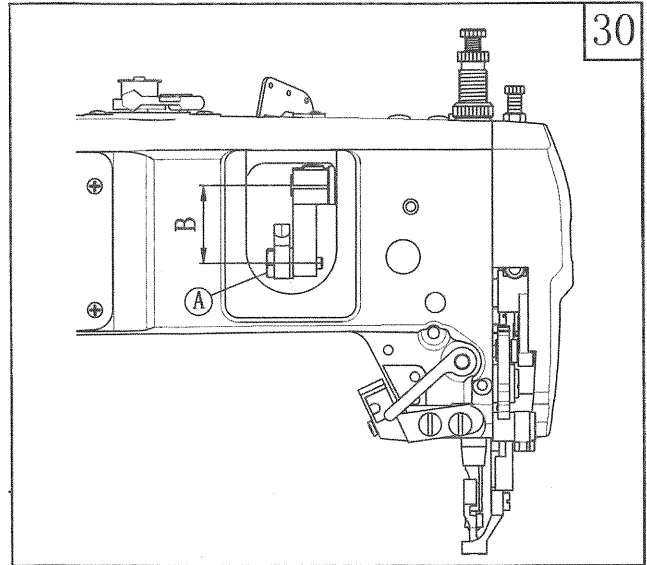

33.摆压脚、压脚前后方向间隙的调节 (图 31)

Adjusting the clearance between the walk foot and pressure foot(Fig.31)

在缝纫过程中,有时用大针距缝纫、有时用小针距缝纫,有时用小针距缝纫,在大针距缝纫时,摆压脚前后的动程比较大。反之,就小了。为了在缝纫过程中,使摆压脚槽的前端与小压脚后端面不碰撞,且保证有一定的间隙C(一般取1.5mm左右)。故在小针距缝纫时,需要摆压脚向上转动压脚摆动轴,则摆压脚就向针杆靠拢,调节时,应该注意间隙C的定值要求。

In practice, long and short stitch will be utilized alternatively. In long stitch, the moving degree of walking foot is always longer, while vice versa. In order to avoid the hitting between the front cave of the walking foot and the back of the pressure and meanwhile keep a certain clearance C(Generally $\pm 1.5\text{mm}$) So, when in short stitch, the walking foot should be closer to the needle bar. Method: Loose the screw of the linking adjusting crank and turn the shaft upward to make the walking foot close to the needle. When adjusting, the clearance C must be considerate.

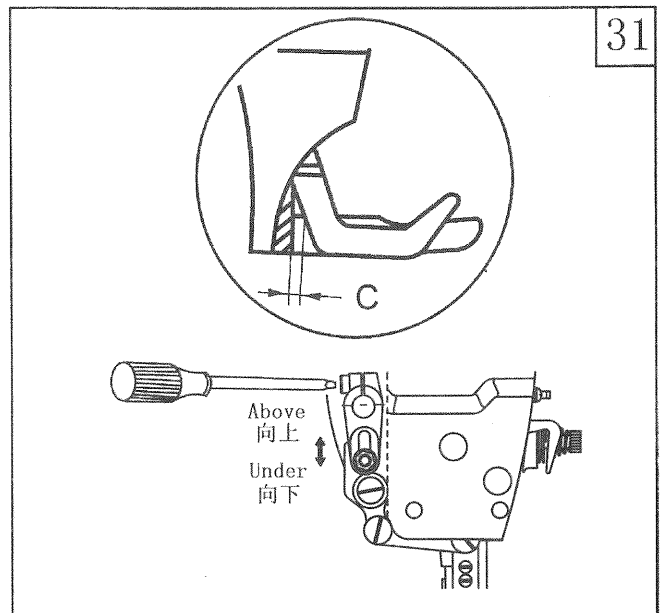

34.剪线装置的调整/ADJUST THE THREAD TRIMMER DEVICE

1. 剪线装置（结构见图 32） / The thread trimmer device (Pic32)

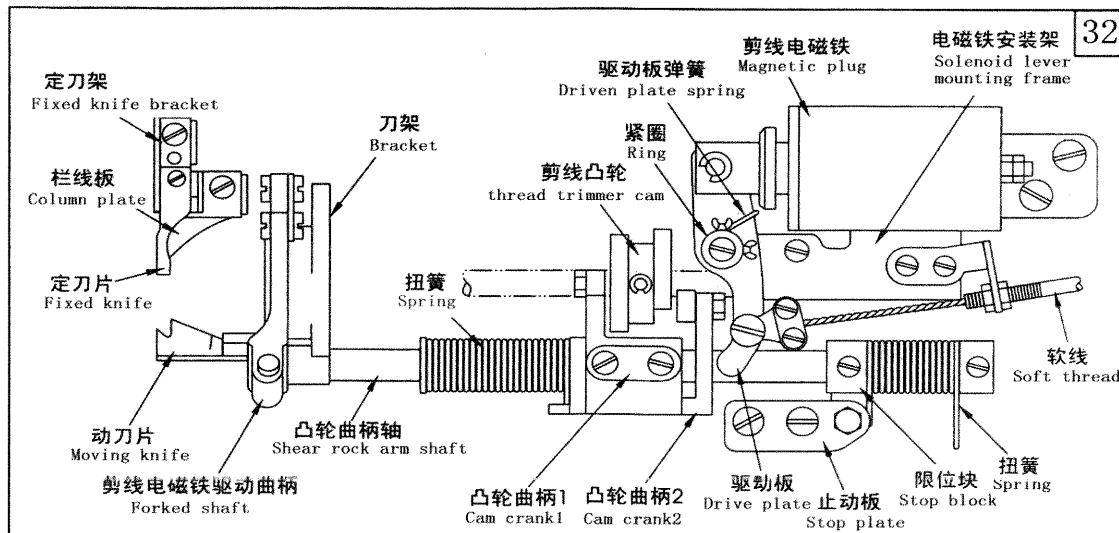

2. 定刀片与动刀片的关系：（见图 33）

The relation of fixed knife and moving knife (Pic33)

- (1) 定刀片①与动刀片②的位置应保证 0.3mm。
 - (2) 可以如图所示进行调整定刀座或定刀片的位置。
 - (3) 移开旋梭定位勾，安装定刀座。
- (1) Keep the fixed knife ① and moving knife ② distance 0.3mm.
- (2) As shown in picture to adjust the install knife holder or fixed knife position.
- (3) Remove the hook positioned. Install the fixed knife holder.

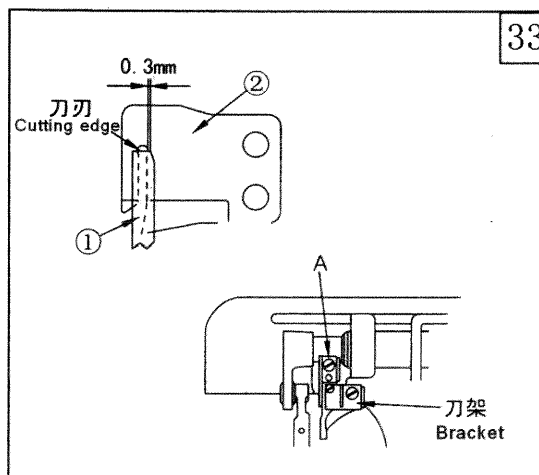

3. 凸轮曲柄轴（见图 34）

The shear rock arm shaft Pic34)

- (1) 装配时，将凸轮曲柄轴①最先装在底板上。
 - (2) 凸轮曲柄 1 必须如图所示安装，固定在凸轮曲柄轴①上的平面处。
 - (3) 轻轻转动凸轮曲柄轴①，将限位块②安装在凸轮曲柄轴①上的平面处。
- (1) Install the shear rock arm shaft ① first.
- (2) Cam crank1 must install as shown in picture, fixed in the plane of shear rock arm shaft ①.
- (3) Turning shear rock arm shaft ① lightly, install the stop block ② in the plane of shear rock arm shaft ①.

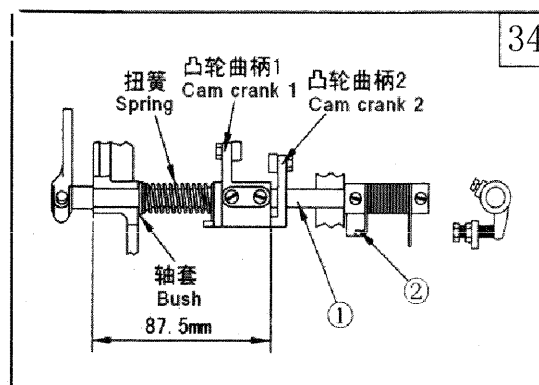

4. 安装剪线电磁铁（见图 35）

Install the magnetic plug (Pic35)

(1) 剪线电磁铁的行程:

- a. 标准的行程为 6.0mm。
- b. 通过调节螺母 A 来调节行程。

(2) 安装剪线电磁铁:

- a. 剪线电磁铁用螺钉 B 和 C 来固定。
- b. 在安装时，必须保证驱动板①与凸轮曲柄②之间的间隙 1mm。
- c. 电磁铁工作时，凸轮曲柄③与凸轮曲柄②之间会有 0.5mm 的间隙，这是标准的情况。如需调整可以如图 26 所示箭头方向滑动电磁铁安装架。

(1) Magnetic plug stroke:

- a. The standard stroke is 6.0 mm.
- b. Adjust the stroke by the adjust the net A.

(2) Install the magnetic plug:

- a. Fixed the magnetic plug by the screw B and screw C.
- b. Keep the drive plate① and cam crank② gap is 1 mm between when install.
- c. When the magnetic plug work, cam crank③ and cam crank② gap is 0.5mm, this is standard situation. If need adjust can slide the magnetic plug install holder see the arrow direction of pic26.

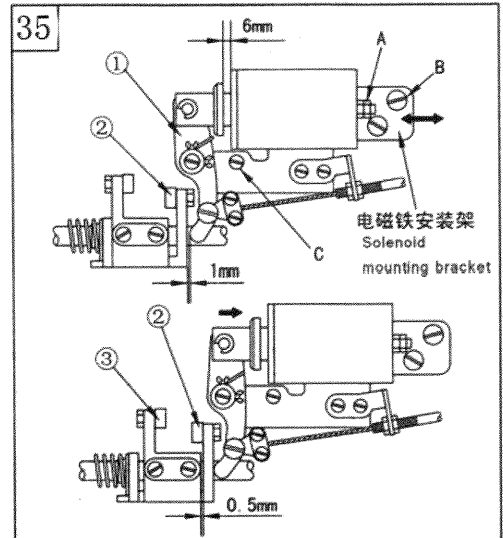

5. 安装剪线凸轮（见图 36）

Install thread trimmer cam (Pic36)

(1) 当挑线杆在最高位置时，将剪线电磁铁开动向前旋转剪线凸轮①直到接触滚柱，然后固定凸轮。

(2) 剪线电磁铁关闭，使凸轮曲柄②回复到原始位置，这样凸轮与滚柱端面将会产生 0.5-1.0mm 的标准间隙。

(1) When the thread take-up in the highest position, Open the magnetic plug to forward, rotation the thread trimmer cam crank① till to touch the pin roller, then fixed the cam.

(2) Closed the magnetic plug, make the cam crank② and pin roller standard gap is 0.5-1.0mm.

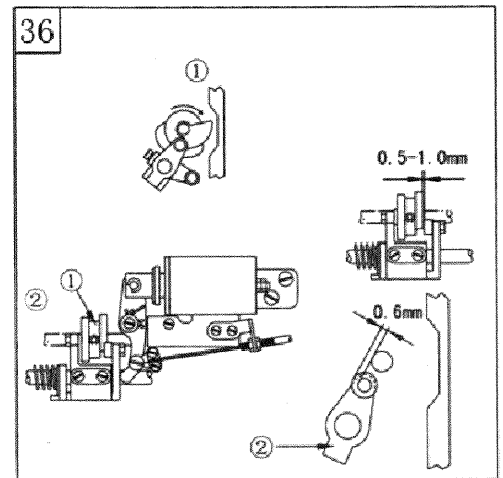

6. 刀片的调整（见图 37）

(1) 动刀片与定刀片的关系:

如图所示，动刀片①与机针中心的距离为 7.5mm，定刀片②与机针中心的距离为 5mm。

(2) 刀片的调整: 开动电磁铁，启动机器。这样，剪线凸轮会使动力片①右旋转。当动刀片①左移动到其最远位置时，与定刀片②的间隙为 1.5-2.0mm。

(3) 剪线电磁铁的调整:

A. 如果剪线情况不良，尤其当线较粗时，只需增加剪线压力即可。

B. 剪线压力可如下所述进行调整: 松开螺母 B，通过调节螺钉 A 来调节螺母 B。

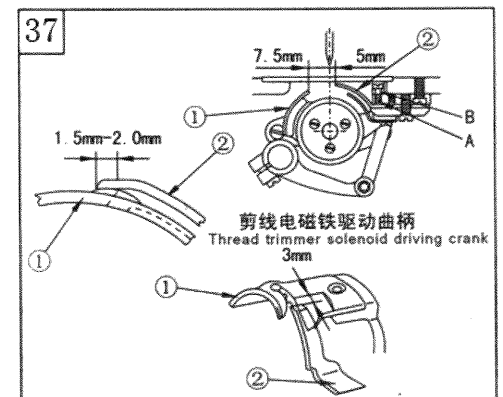

6. Adjust the knife (Pic37)

(1) The relation of fixed knife and moving knife:

As the picture shown, moving knife① and the needle center distance is 7.5mm fixed knife② and needle center distance is 5 mm.

(2) Adjust the knife: Open the magnetic plug, operation the machine. So thread trimmer cam can make the moving knife① turning right. When the moving knife① turning left the farthest position, moving knife and fixed knife② gap is 1.5-2.0mm.

(3) Adjust the magnetic plug :

A. When the trimmer situation is not good, only increase the tension especially the thread more heavy.

B. The trimmer tension can adjust as follow: Loosen screw B, adjust screw A to adjust screw B.

35.清扫 (图 38) /CLEANING (PIG38)

1. 抬起压脚。拧开两螺钉①，然后卸下针板②。
2. 使用软毛刷对送布牙进行清扫。
3. 装上针板②及拧紧两螺钉①。
4. 缓慢转动上轮，观察机针是否落入针板孔的中心位置。
 - 如果机针不是落入中心位置，检查机针是否弯曲。
 - 松开两螺钉①，然后重新安装针板②。
5. 转动上轮将机针上升至针板以上，然后观察机针针尖是否钝挫，如果钝挫则更换机针。
6. 放倒机头。卸下梭芯套④。
7. 用软布将旋梭中的灰尘擦除干净，并检查旋梭是否被损坏。
8. 将梭芯从梭芯套中拿出，用布将梭芯擦干净。
9. 将梭芯放入梭芯套中，然后将梭芯套装入旋梭中。
10. 清除油泵滤网 (A) 上的尘屑。

1. Lift the pressure foot. Rive the two screw①, then unload the needle plate②.
2. Use the soft hairbrush to clean the feed dog.
3. Install the needle plate② and tighten the two screw①.
4. Turning the upper wheel, observe the needle fall into the needle plate hole or not.
 - If the needle is not fall into the center, Inspect the needle is bend or not.
 - Loosen the two screw①, then reinstall the needle plate②.
5. Turning the upper wheel make the needle rise to the Exceed needle plate , then observe the needlepoint is contusion or not , if contusion need to replace the needle.
6. Lay down the machine body .Unload the bobbin case④.
7. Use the soft cloth to clean the hook dust, inspect the hook is damaged or not.
8. Make the bobbin out of the bobbin in case, then use the cloth to clean the bobbin case.
9. Put the bobbin into the bobbin case, then put the bobbin case into the hook.
10. Cleaning the dust of the oil pump screen (A).

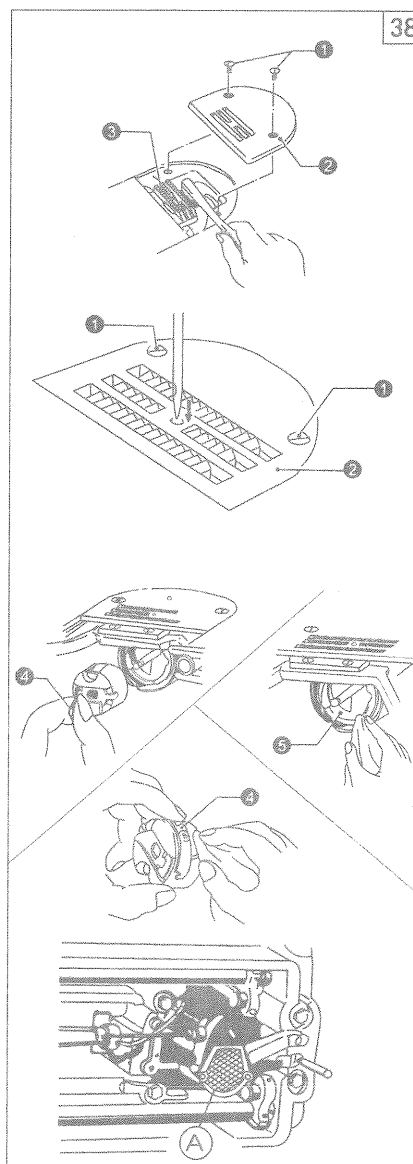

零件手册

PARTS BOOK

A. 机壳部件 / ARM MECHANISM

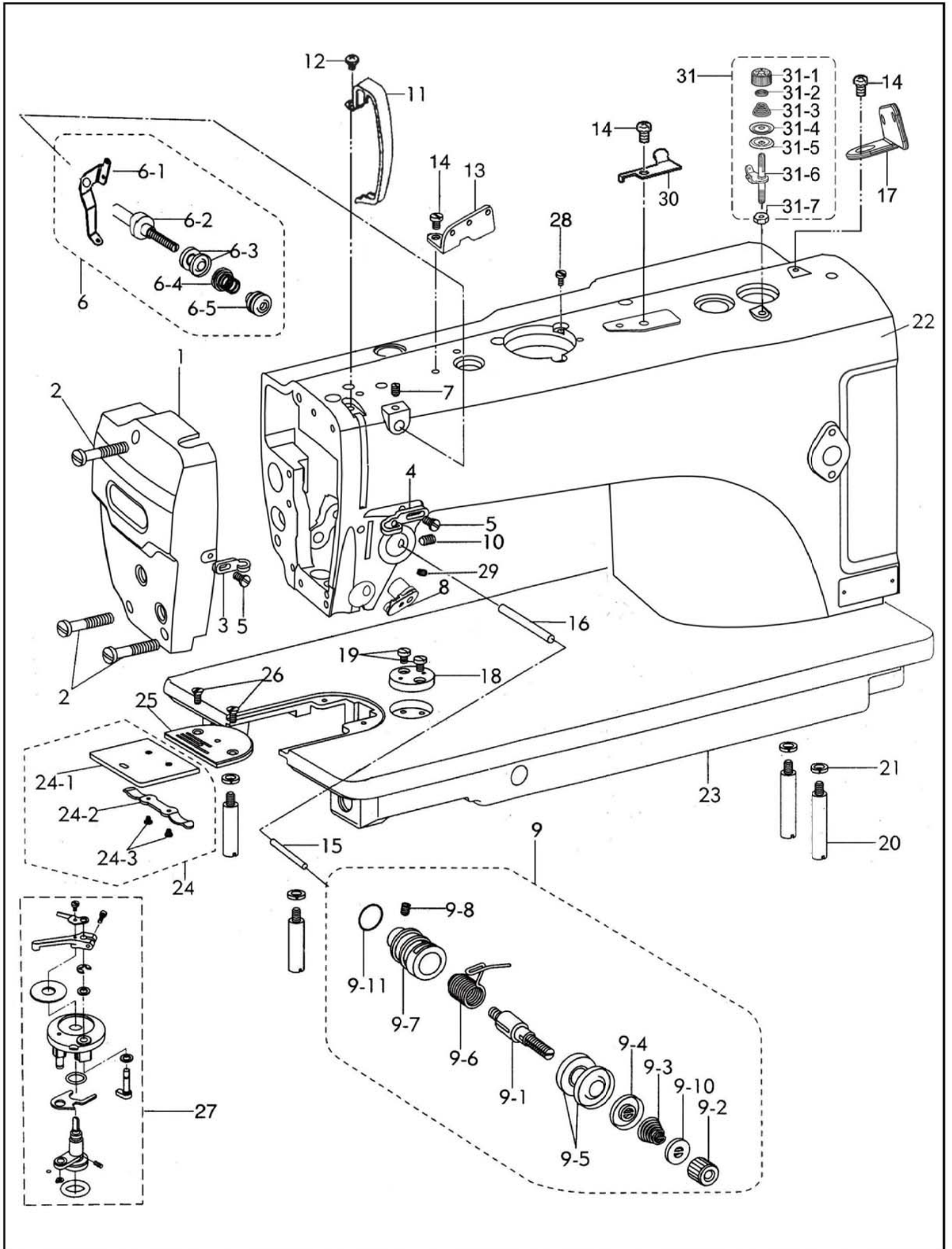

A. 机壳部件/ARM MECHANISM

零件编号 Parts No.	名称 Description	数量 Quantity	备注 Remarks
C2206-19-1	面板 Face plate	1	
C2206-19-2	面板螺钉 Face plate screw	3	
C2206-19-3	面板线勾 Face plate thread guide	1	
C2206-19-4	线勾 Thread guide	1	
C2206-19-5	面板线勾螺钉 Face plate thread guide screw	2	
C2206-19-6	小夹线组件 Bobbin thread tension asm	1	
C2206-19-6-1	小夹线过线板 Bobbin thread tension rod	1	
C2206-19-6-2	小夹线螺钉 Screw type tension stud	1	
C2206-19-6-3	小夹线板夹 Disc for pretension	2	
C2206-19-6-4	小夹线弹簧 Spring for pretension	1	
C2206-19-6-5	小夹线螺母 Nut type tension stud	1	
C2206-19-7	小夹线固定螺钉 Screw	1	
C2206-19-8	电子夹线器 Electronic thread clamp device	1	
C2206-19-9	夹线组件 Thread tension asm	1	
C2206-19-9-1	夹线螺钉 Thread tension screw	1	
C2206-19-9-2	夹线螺母小组件 Tension devices net asm	1	
C2206-19-9-3	夹线弹簧 Tension devices spring	1	
C2206-19-9-4	松线板 Thread tension plate	1	
C2206-19-9-5	夹线板 Tension devices plate	2	
C2206-19-9-6	挑线簧 Thread take-up spring	1	
C2206-19-9-7	夹线调节座 Thread tension regulation holder	1	
C2206-19-9-8	紧固螺钉 Screw	1	
C2206-19-9-10	夹线螺母止动板 Thread tension net stop plate	1	
C2206-19-9-11	O 型圈 O-ring	1	
C2206-19-10	夹线调节座固定螺钉 Screw	1	
C2206-19-11	挑线杆防护罩 Thread take-up lever cover	1	
C2206-19-12	挑线杆防护罩螺钉 Screw	1	
C2206-19-13	三孔线勾 Three holes thread guide plate	1	
C2206-19-14	螺钉 Screw	3	
C2206-19-15	松线钉 Thread tension pin	1	
C2206-19-16	松线销 Thread release pin	1	
C2206-19-17	二孔线勾 Two holes thread guide plate	2	
C2206-19-18	夹边座 Cloth guide plate	1	
C2206-19-19	夹边座螺钉 Set screw	2	
C2206-19-20	底板撑杆 Bed screw stud	4	
C2206-19-21	弹簧垫圈 Spring washer	4	
C2206-19-22	机壳 Arm	1	
C2206-19-23	底板 Bed	1	
C2206-19-24	推板组件 Slide plate asm	1	
C2206-19-24-1	推板 Slide plate	1	

A. 机壳部件 / ARM MECHANISM

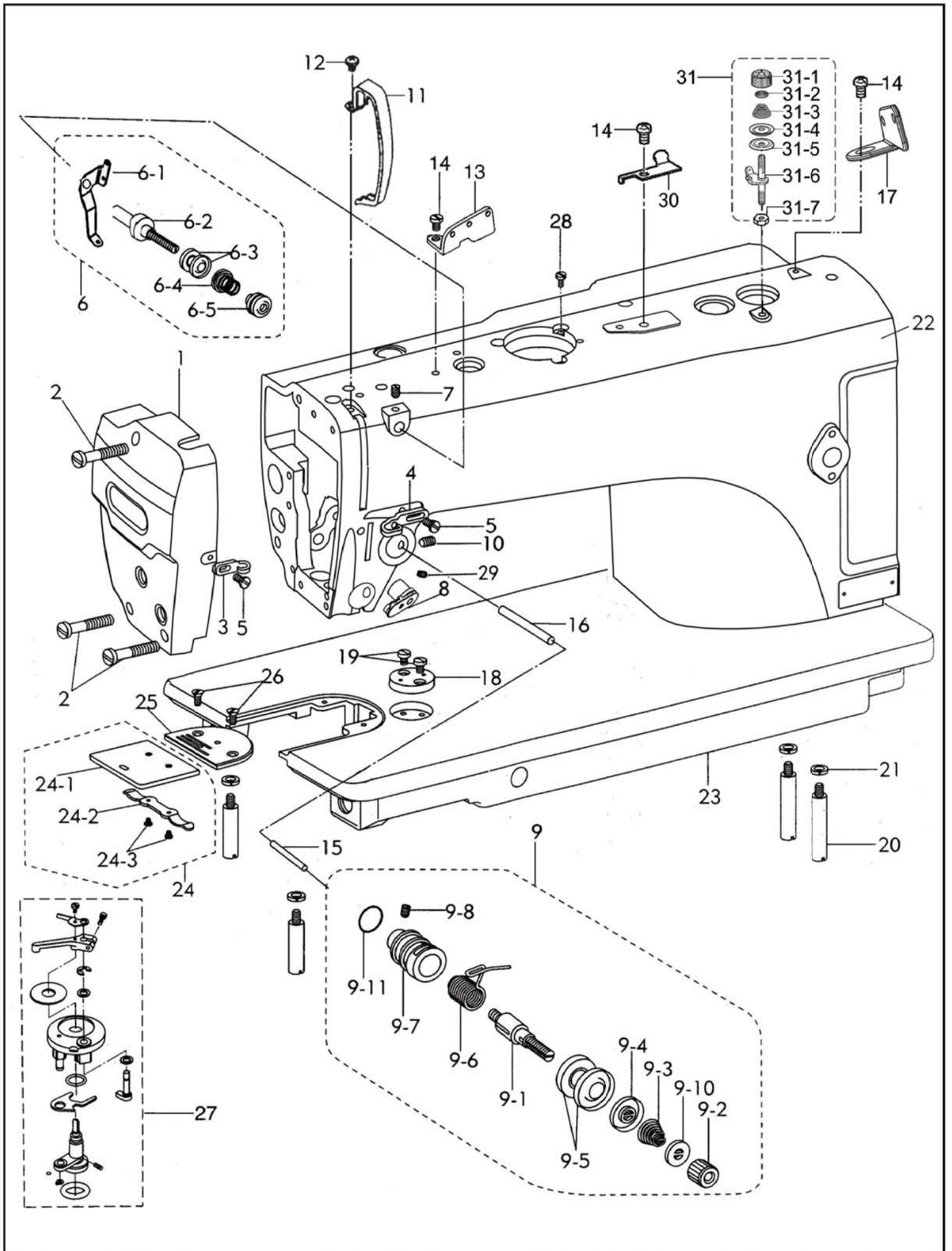

A. 机壳部件/ARM MECHANISM

零件编号 Parts No.	名称 Description	数量 Quantity	备注 Remarks
C2206-19-24-2	推板簧 Slide plate spring	1	
C2206-19-24-3	推板螺钉 Slide plate screw	2	
C2206-19-25	针板 Needle plate	1	
C2206-19-26	针板螺钉 Needle plate screw	2	
C2206-19-27	绕线器组件 Bobbin winder unit	1	
C2206-19-28	绕线器组件固定螺钉 Screw	3	
C2206-19-29	紧固螺钉 Screw	1	
C2206-19-30	切刀 Knife	1	
C2206-19-31	绕线器小夹线器组件 Bobbin thread tension asm	1	
C2206-19-31-1	压线螺母 Tension nut	1	
C2206-19-31-2	止动垫圈 Washer	1	
C2206-19-31-3	夹线弹簧 Tension spring	2	
C2206-19-31-4	小夹线器固定螺钉 Screw	1	
C2206-19-31-5	夹线盘 Disc tension	1	
C2206-19-31-6	调线过线板 Thread tension guide	1	
C2206-19-31-7	紧固螺母 Nut	1	
		1	

B. 针杆、挑线部件/NEEDLE BAR AND THREAD TAKE-UP MECHANISM

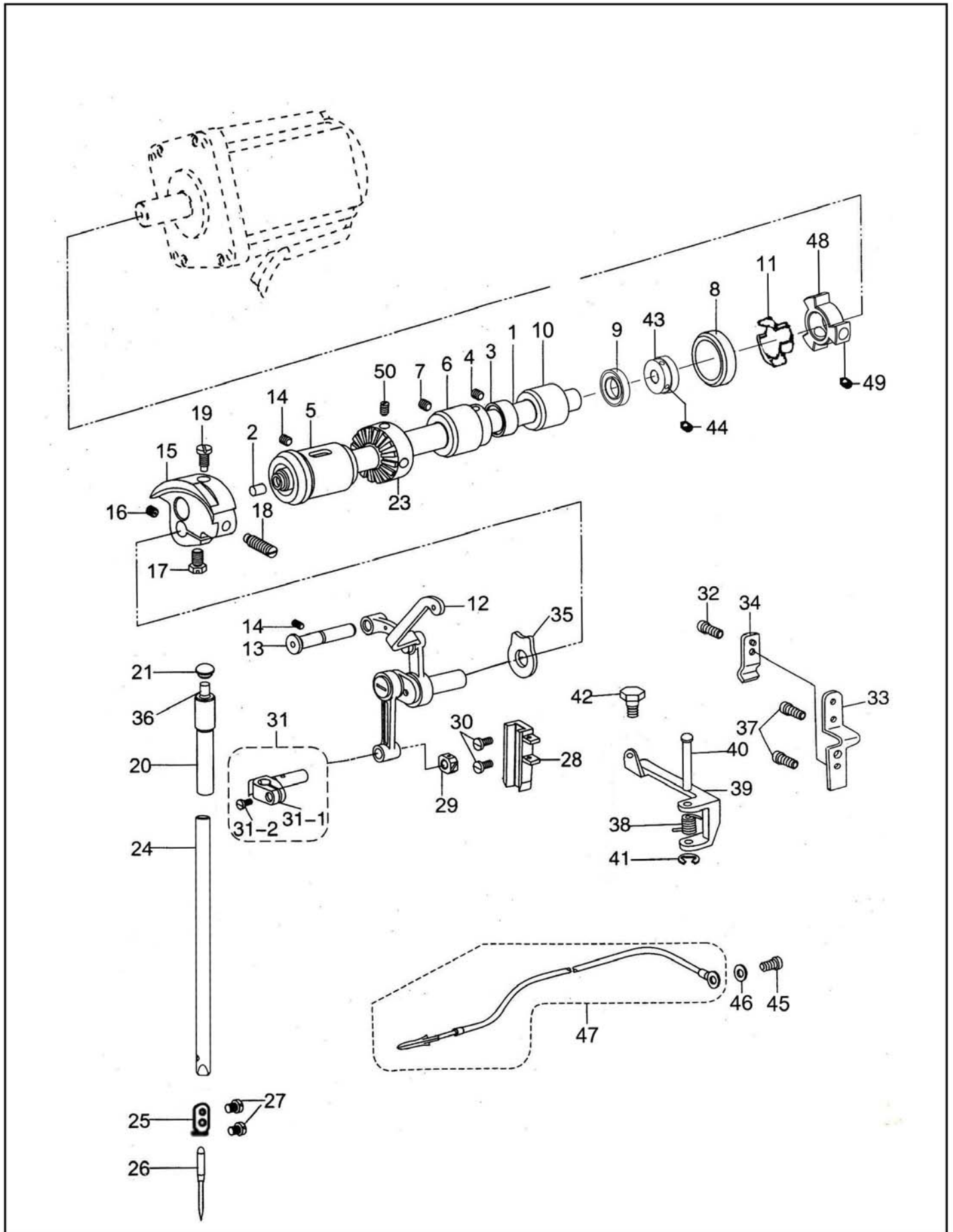

B. 针杆、挑线部件/NEEDLE BAR AND THREAD TAKE-UP MECHANISM

零件编号 Parts No.	名称 Description	数量 Quantity	备注 Remarks
C2206-23-1	上轴 Arm shaft	1	
C2206-23-2	上轴橡皮塞 Rubber plug	1	
C2206-23-3	上轴紧圈 Collar for arm shaft	1	
C2206-23-4	上轴紧圈螺钉 Set screw	2	
C2206-23-5	上轴轴套(左) Arm shaft bushing(left)	1	
C2206-23-6	上轴轴套(中) Arm shaft bushing(middle)	1	
C2206-23-7	上轴轴套(中) 螺钉 Set screw	1	
C2206-23-8	上轴轴承 Needle bearing	1	
C2206-23-9	上轴油封 Oil seal	1	
C2206-23-10	上轴轴套(右) Arm shaft bushing(Right)	1	
C2206-23-11	联轴器橡胶圈 Rubber ring	1	
C2206-23-12	挑线杆组件 Thread take-up asm	1	
C2206-23-13	挑线连杆铰链轴 Hinge pin	1	
C2206-23-14	挑线连杆铰链轴螺钉 Set screw	2	
C2206-23-15	挑线曲柄 Needle bar link	1	
C2206-23-16	挑线曲柄螺钉 Screw	1	
C2206-23-17	挑线曲柄定位螺钉 Set screw	1	
C2206-23-18	针杆曲柄螺钉 Screw	1	
C2206-23-19	针杆曲柄定位螺钉 Set screw	1	
C2206-23-20	针杆轴套(上) Needle bar shaft bushing(upper)	1	
C2206-23-21	针杆轴套(上) 橡皮塞 Rubber plug(upper)	1	
C2206-23-23	驱动轮 Btw-driving-wheel	1	
C2206-23-24	针杆 Needle bar	1	
C2206-23-25	针杆过线环 Thread guide for needle bar	1	
C2206-23-26	机针 Needle	1	
C2206-23-27	夹线螺钉 Needle clamp screw	2	
C2206-23-28	滑块槽 Needle bar trough	1	
C2206-23-29	针杆接头滑块 Slide blood	1	
C2206-23-30	滑块导杆螺钉 Set screw	2	
C2206-23-31	针杆接头组件 Needle bar connection asm	1	
C2206-23-31-1	针杆接头 Needle bar adaptor	1	
C2206-23-31-2	针杆接头螺钉 Set screw	1	
C2206-23-32	软线固定板螺钉 Screw	1	
C2206-23-33	松线钢绳固定架 Loose thread rope fixed frame	1	
C2206-23-34	松线压板 Loose thread presser plate	1	
C2206-23-35	垫片 Washer plate	1	
C2206-23-36	针杆上轴套毛毡 Oil felt for needle bar	1	
C2206-23-37	松线钢绳固定架螺钉 Screw	2	
C2206-23-38	铰链弹簧 Spring	1	

B. 针杆、挑线部件/NEEDLE BAR AND THREAD TAKE-UP MECHANISM

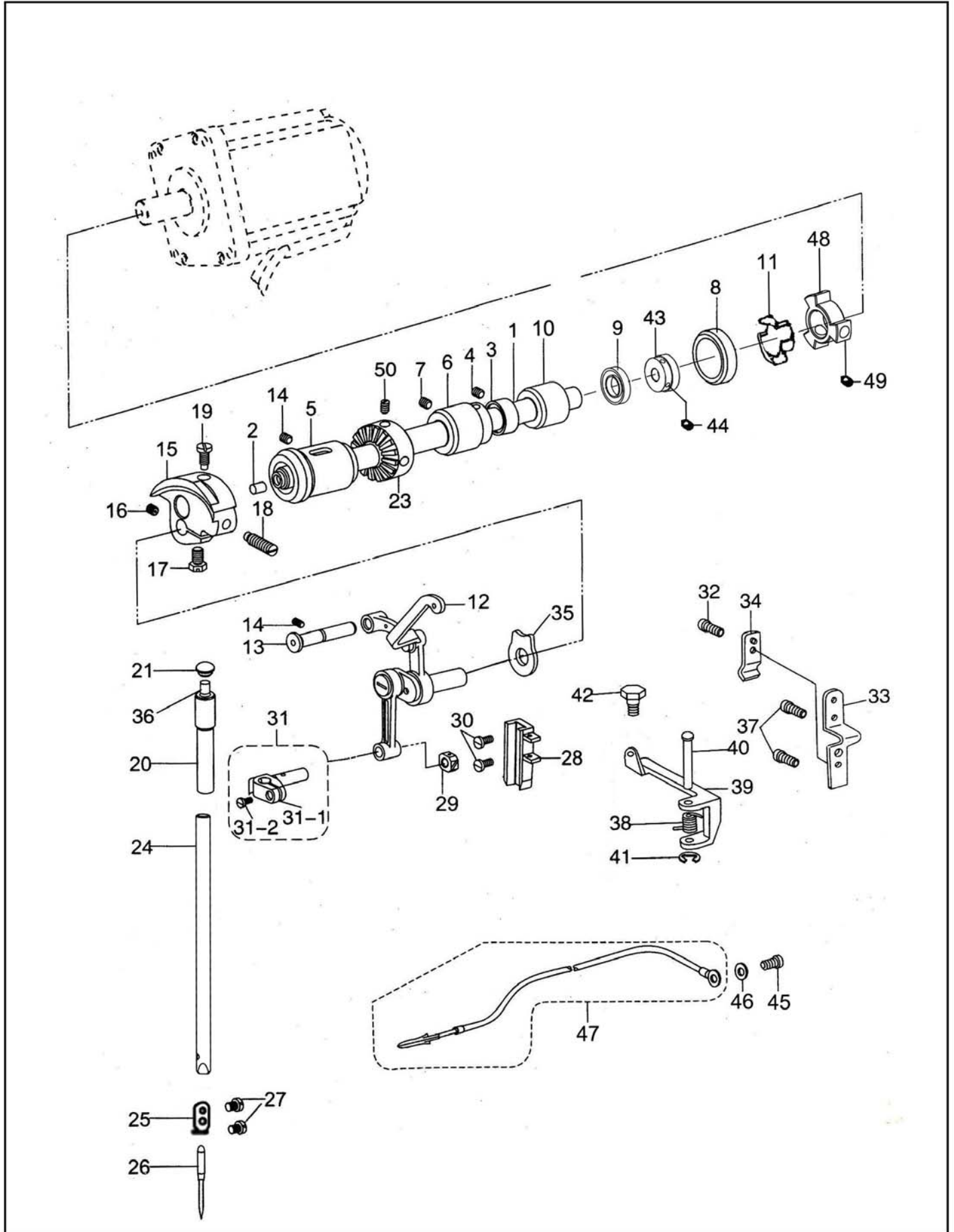

B. 针杆、挑线部件/NEEDLE BAR AND THREAD TAKE-UP MECHANISM

零件编号 Parts No.	名称 Description	数量 Quantity	备注 Remarks
C2206-23-39	松线铰链 Loose thread hinge	1	
C2206-23-40	松线销 Pin	1	
C2206-23-41	开口挡圈 Retaining ring	1	
C2206-23-42	铰链螺钉 Screw	1	
C2206-23-43	联轴器 Connect block	1	
C2206-23-44	联轴器螺钉 Screw	2	
C2206-23-45	地线螺钉 Screw	1	
C2206-23-46	地线垫片 Washer	1	
C2206-23-47	地线组件 Ground wire asm	1	
C2206-23-48	联轴器 Linker	1	
C2206-23-49	螺钉 Screw	1	
C2206-23-50	驱动轮螺钉 Btw-driving-wheel screw	2	

C. 送料部件 / FEED MECHANISM COMPONENTS

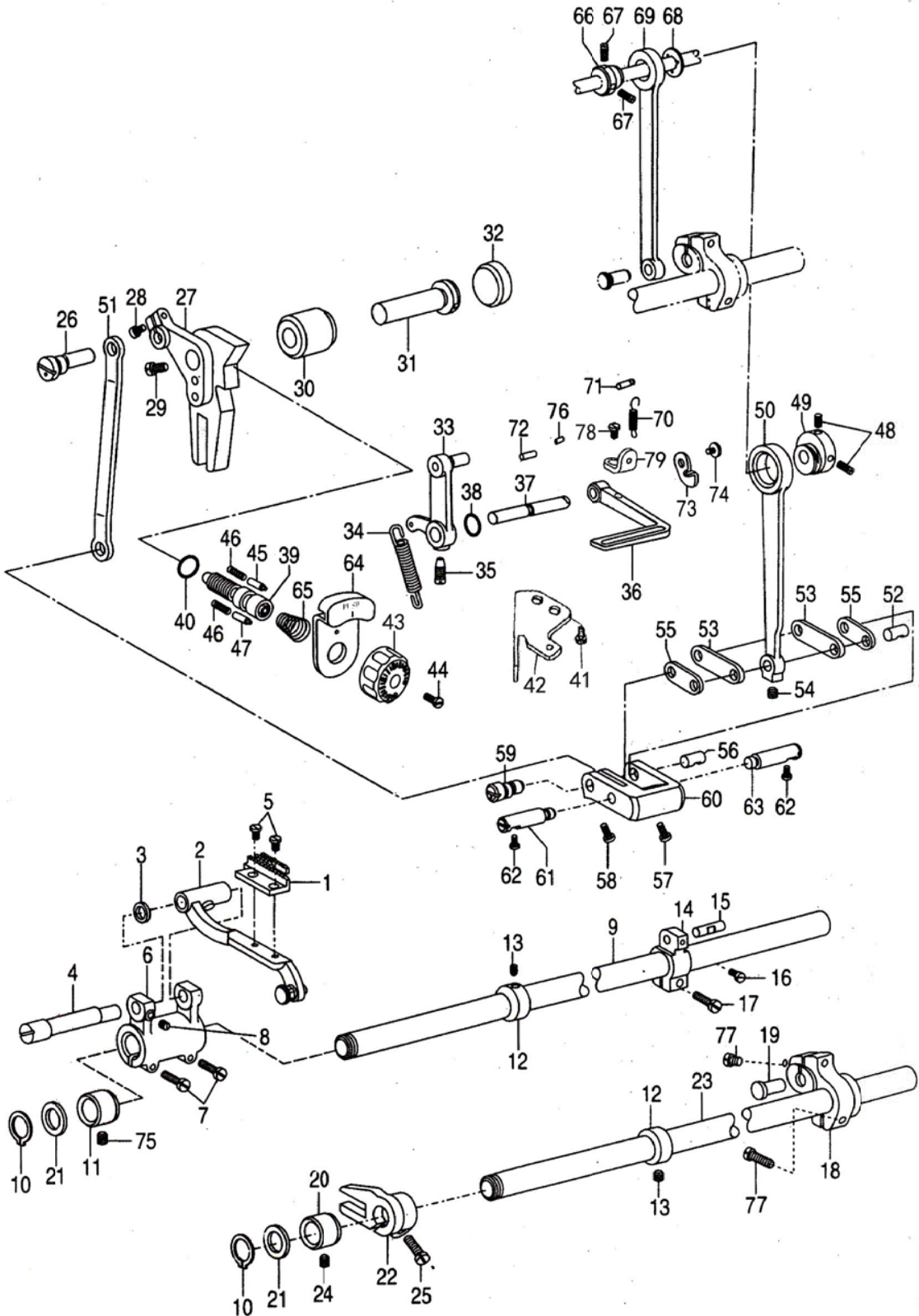

C. 送料部件/ FEED MECHANISM COMPONENTS

零件编号 Parts No.	名称 Description	数量 Quantity	备注 Remarks
C2206-27-1	送布牙 Feed dog	1	
C2206-27-2	牙架组件 Feed bar assembly	1	
C2206-27-3	牙架垫圈 Washer	1	
C2206-27-4	牙架偏心轴 Shaft for feed bar	1	
C2206-27-5	送布牙螺钉 Screw	2	
C2206-27-6	牙架曲柄 Feed rock crank	1	
C2206-27-7	牙架曲柄螺钉 Screw	2	
C2206-27-8	牙架曲柄偏心轴螺钉 Screw	1	
C2206-27-9	送布轴 Feed rock shaft	1	
C2206-27-10	轴用弹性挡圈 Type stop ring	2	
C2206-27-11	送布轴轴套 Collar for feed lifting rock shaft	1	
C2206-27-12	送布轴紧圈 Collar for feed lifting rock shaft	2	
C2206-27-13	送布轴紧圈螺钉 Screw	4	
C2206-27-14	送布轴曲柄 (右) feed rock shaft craned (right)	1	
C2206-27-15	曲柄连杆短销 Hinge Pin	1	
C2206-27-16	曲柄连杆短销螺钉 Screw	1	
C2206-27-17	送布轴曲柄 (右)螺钉 Screw	1	
C2206-27-18	抬牙轴曲柄 (右) feed rock shaft craned (right)	1	
C2206-27-19	抬牙轴曲柄铰链轴 Hinge Pin	1	
C2206-27-20	抬牙轴轴套 Feed rock lifting shaft	1	
C2206-27-21	抬压轴轴套垫圈 Screw	2	
C2206-27-22	抬牙叉 Feed forked connection	1	
C2206-27-23	抬牙轴 Feed lifting rock shaft	1	
C2206-27-24	抬牙轴前轴套螺钉 Screw	1	
C2206-27-25	抬牙叉夹紧螺钉 Screw	1	
C2206-27-26	针距调节连杆销 Hinge pin	1	
C2206-27-27	针距座 Feed regulator	1	
C2206-27-28	针距座长螺钉 Screw	1	
C2206-27-29	针距座短螺钉 Screw	1	
C2206-27-30	针距座衬套 Feed regulator bushing	1	
C2206-27-31	针距座轴 Hinge pin for feed regulator	1	
C2206-27-32	橡皮塞 (ø15.7) Rubber plug	1	
C2206-27-33	倒缝操纵杆曲柄组件 Slide block pin asm	1	
C2206-27-34	倒缝操纵杆曲柄弹簧 Spring for feed crank	1	
C2206-27-35	操纵杆曲柄螺钉 Screw	1	
C2206-27-36	倒缝扳手 Reverse feed lever	1	
C2206-27-37	倒缝扳手轴 Reverse feed lever shaft	1	
C2206-27-38	倒缝扳手轴 O 型圈 O-ring	1	
C2206-27-39	针距调节螺杆 Feed regulator screw bar	1	
C2206-27-40	O 型橡胶圈 O-ring	1	
C2206-27-41	弹簧架螺钉 Screw	2	

C. 送料部件 / FEED MECHANISM COMPONENTS

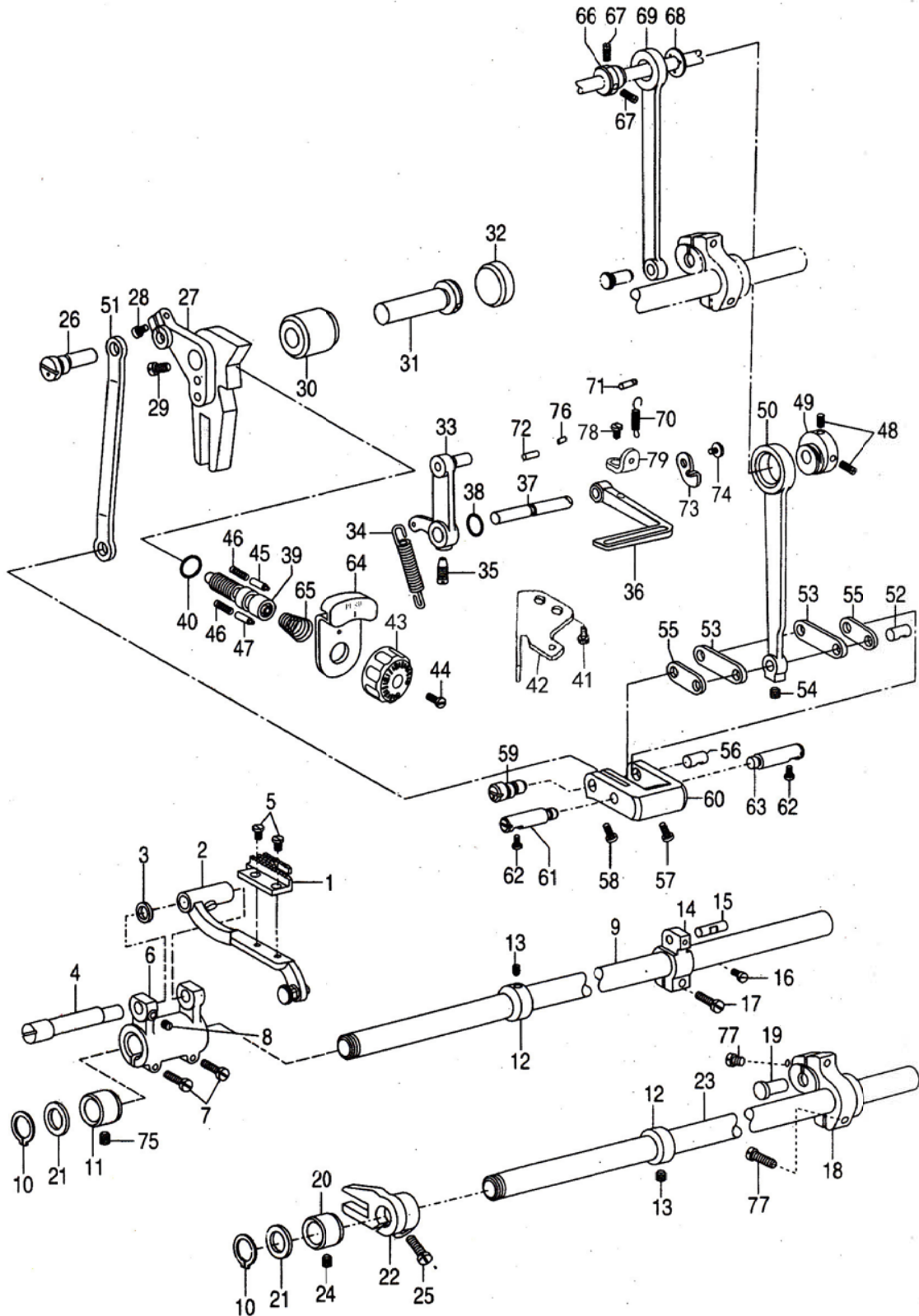

C. 送料部件/ FEED MECHANISM COMPONENTS

零件编号 Parts No.	名称 Description	数量 Quantity	备注 Remarks
C2206-27-42	弹簧架 Spring stand	1	
C2206-27-43	针距标盘 Dial face	1	
C2206-27-44	针距盘螺钉 Screw	1	
C2206-27-45	止动销 Stopper pin	1	
C2206-27-46	止动销弹簧 Spring for stopper pin	2	
C2206-27-47	针距盘挡销 Dial stopper pin	1	
C2206-27-48	送布凸轮螺钉 Screw	3	
C2206-27-49	送布凸轮 Feed drive eccentric cam	1	
C2206-27-50	送布连杆 Rocker shaft connecting rod	1	
C2206-27-51	针距调节连杆 Feed regulator connecting rod	1	
C2206-27-52	曲柄连杆长销 Walking foot pin	1	
C2206-27-53	曲柄长连杆 Walking foot link	2	
C2206-27-54	送布连杆螺钉 Screw	1	
C2206-27-55	曲柄短连杆 connecting link	2	
C2206-27-56	曲柄连杆短销 Walking foot pin	1	
C2206-27-57	短连杆销螺钉 Screw	1	
C2206-27-58	连杆偏心轴螺钉 Screw	2	
C2206-27-59	连杆偏心轴 Hinge pin	1	
C2206-27-60	针距调节曲柄 Walking foot adjusting link	1	
C2206-27-61	针距调节曲柄定位销（左） Adjusting link fulcrum shaft	1	
C2206-27-62	左、右定位销螺钉 Screw	2	
C2206-27-63	针距调节曲柄定位销（右） Adjusting link fulcrum shaft	1	
C2206-27-64	针距按键 Feed regulator key-press	1	
C2206-27-65	针距按键簧 Dial spring for stopper pin	1	
C2206-27-66	抬牙凸轮 Feed drive eccentric cam	1	
C2206-27-67	抬牙凸轮螺钉 Screw	3	
C2206-27-68	凸轮隔离片 Thrust collar	1	
C2206-27-69	抬牙连杆 Connecting rod	1	
C2206-27-70	弹簧 spring	1	
C2206-27-71	弹簧销 Pin for spring	1	
C2206-27-72	倒缝扳手限位销	1	
C2206-27-73	倒缝扳手板	1	
C2206-27-74	倒缝扳手轴螺钉 Screw	1	
C2206-27-75	送布轴前轴套螺钉 Screw	1	
C2206-27-76	销套	1	
C2206-27-77	抬牙右曲柄螺钉 Screw	1	
C2206-27-78	拉簧架螺钉 Screw	1	
C2206-27-79	弹簧架 Spring stand	1	

D. 上送料部件 / FEED MECHANISM

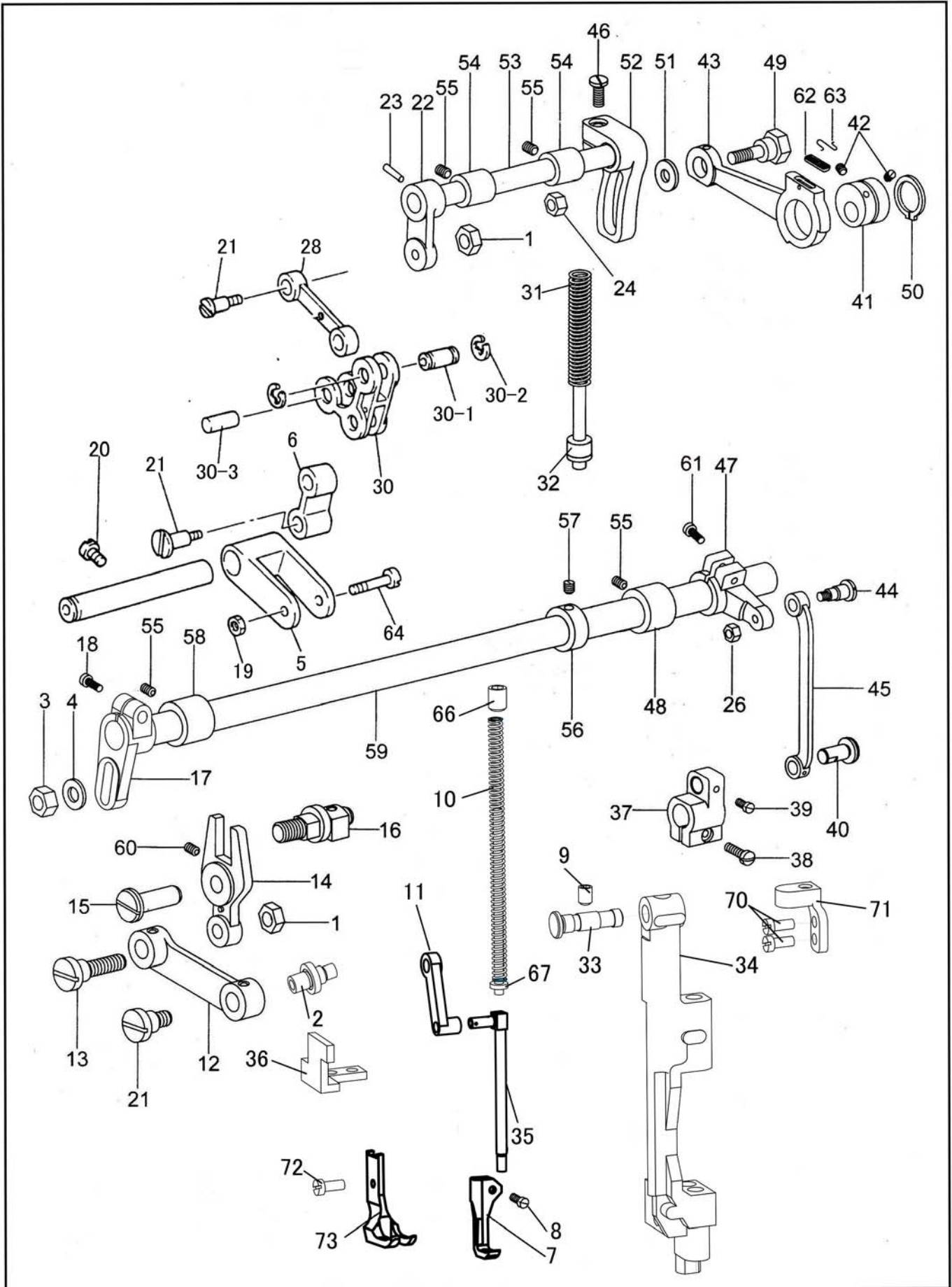

D. 上送料部件/FEED MECHANISM

零件编号 Parts No.	名称 Description	数量 Quantity	备注 Remarks
C2206-31-1	压脚送料变动连接螺母 Nut	2	
C2206-31-2	针杆摆动架连接螺钉 Screw	1	
C2206-31-3	压脚曲柄连接螺母 Nut	1	
C2206-31-4	压脚曲柄连接垫圈 Washer	1	
C2206-31-5	摆杆 Bell crank supporter	1	
C2206-31-6	连接杆 Link	1	
C2206-31-7	摆压脚 Working foot	1	
C2206-31-8	压脚螺钉 Screw	1	
C2206-31-9	M6 紧定螺钉 Screw	2	
C2206-31-10	摆动脚调压脚弹簧 Sping	1	
C2206-31-11	摆压脚杆 Link	1	
C2206-31-12	摆压脚连杆 Link of walking foot	1	
C2206-31-13	压脚送料变动连接螺钉 Screw	1	
C2206-31-14	摆压脚叉型杆 Fork lever	1	
C2206-31-15	摆压脚叉型杆销 Pin	1	
C2206-31-16	压脚送料变动曲柄轴组件 Crank shaft complete	1	
C2206-31-17	压脚摆动前曲柄 Presser swing crank (left)	1	
C2206-31-18	前曲柄螺钉 Screw	2	
C2206-31-20	M6 紧定螺钉 Screw	1	
C2206-31-21	压脚送料曲柄连杆螺钉 Screw	2	
C2206-31-22	压脚升降前曲柄 Crank	1	
C2206-31-23	圆锥销 Pin	1	
C2206-31-24	六角螺母 Nut	1	
C2206-31-28	压脚送料曲柄连杆 Link	1	
C2206-31-29	压脚送料曲柄螺钉 Screw	2	
C2206-31-30	压脚送料曲柄 Presser foot feed crank	1	
C2206-31-30-1	销子 Pin	1	
C2206-31-30-2	E 型卡圈 E-type stop ring 6	1	
C2206-31-30-3	销子 Pin	1	
C2206-31-31	摆压脚调压杆弹簧 Sping	1	
C2206-31-32	调压杆弹簧导柱 Guide pin	1	
C2206-31-33	销子 Pin	1	
C2206-31-34	针杆摆动架 Needle bar swing frame	1	
C2206-31-35	上送料连杆 Link	1	
C2206-31-36	导向块 Link	1	
C2206-31-37	送布轴曲柄 (中) Feed rock crank (min)	1	
C2206-31-38	送布轴曲柄 (中) 螺钉 Screw	1	
C2206-31-39	大连杆曲柄连接销钉 Screw	1	

D. 上送料部件 / FEED MECHANISM

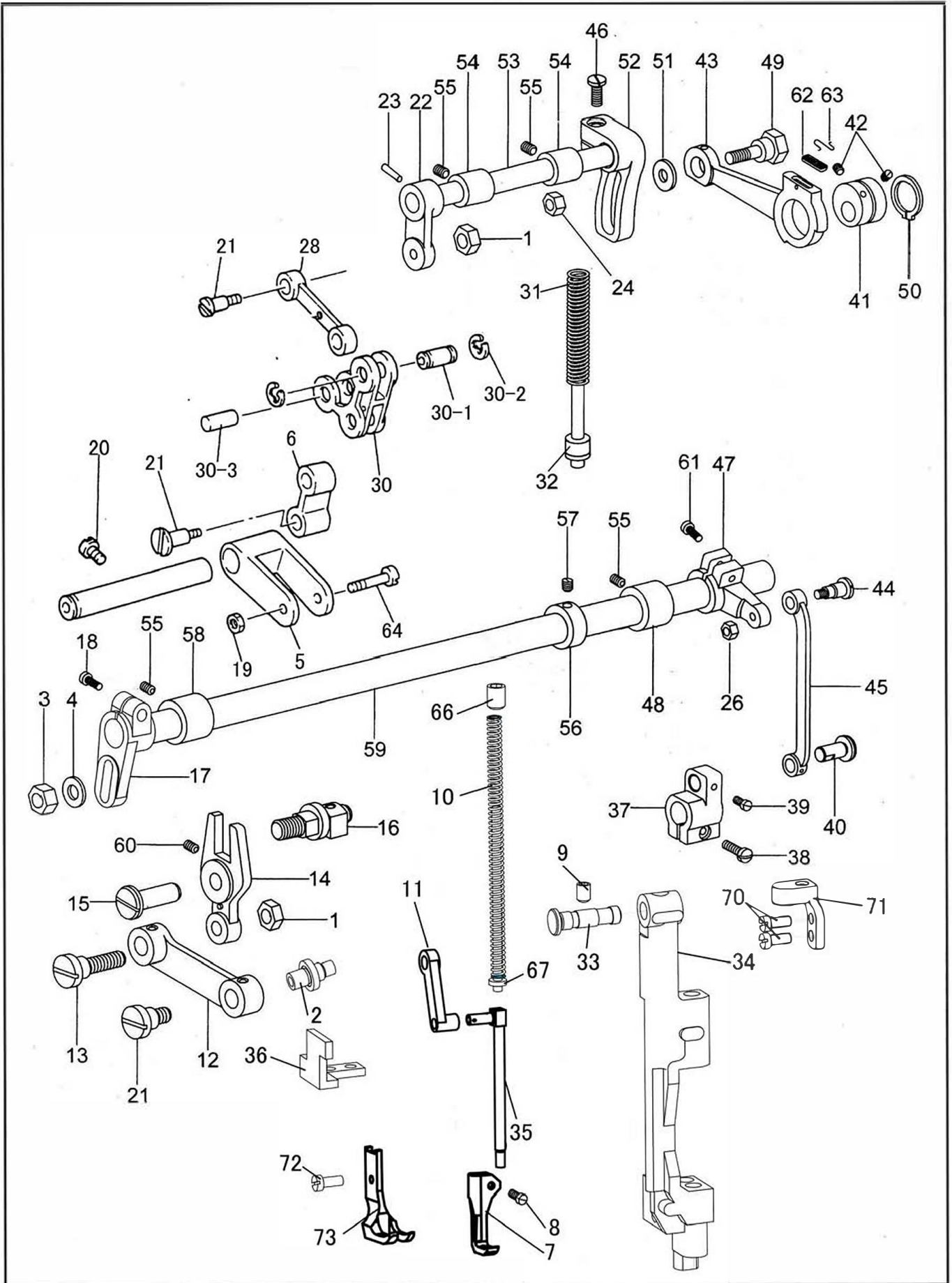

D. 上送料部件/FEED MECHANISM

零件编号 Parts No.	名称 Description	数量 Quantity	备注 Remarks
C2206-31-40	大连杆曲柄连接销 Feed rock crank shaft	1	
C2206-31-41	压脚升降偏心轮 Eccentric cam	1	
C2206-31-42	螺钉 Screw	2	
C2206-31-43	连杆组件 Link complete	1	
C2206-31-44	压脚摆动后曲柄连杆螺钉 Screw	1	
C2206-31-45	摆压脚大连杆 Link	1	
C2206-31-46	偏心连杆调节曲柄螺钉 Screw	1	SM1/4"(6.35)×40/17
C2206-31-47	压脚摆动后曲柄 Pear crank	1	
C2206-31-48	压脚摆动轴中轴套 Rear bushing	1	
C2206-31-49	偏心轮连杆螺钉 Screw	1	
C2206-31-50	轴用 C 型挡圈 Splitring	1	
C2206-31-51	垫圈 Washer	1	
C2206-31-52	偏心连杆调节曲柄 Link adjusting crank	1	
C2206-31-53	压脚升降轴 Presser foot swinI shaft	1	
C2206-31-54	摆压脚提升轴套 Rear bushing	2	
C2206-31-55	摆动升降轴套支头螺钉 Screw	3	SM1/64"(4.37)×40/5
C2206-31-56	压脚摆动轴紧圈 Collar for presser swing shaft	1	
C2206-31-57	压脚摆动轴紧圈螺钉 Screw	2	
C2206-31-58	压脚摆动轴前轴套 Front bushing	1	
C2206-31-59	压脚摆动轴 Presser foot swing shaft	1	
C2206-31-60	摆压脚叉型杆销螺钉 Screw	1	
C2206-31-61	后曲柄螺钉 Screw	1	
C2206-31-62	偏心轮连杆油毡 Oil felt	1	
C2206-31-63	偏心轮连杆油毡压簧 Spring	1	
C2206-31-64	轴位螺钉 Screw	2	
C2206-31-65	压脚提升前轴套 Front bushing	1	
C2206-31-66	M8 紧定螺钉 Screw	1	
C2206-31-67	D-32 调压杆弹簧导柱 guide pillar	1	
C2206-31-70	油孔连接板螺钉 (SM11/64x40) Screw	1	
C2206-31-71	油孔连接板 Plte	1	
C2206-31-72	外压脚螺钉 Screw	1	
C2206-31-73	外压脚 The presser foot	1	

E. 压脚部件 / PRESSER FOOT MECHANISM

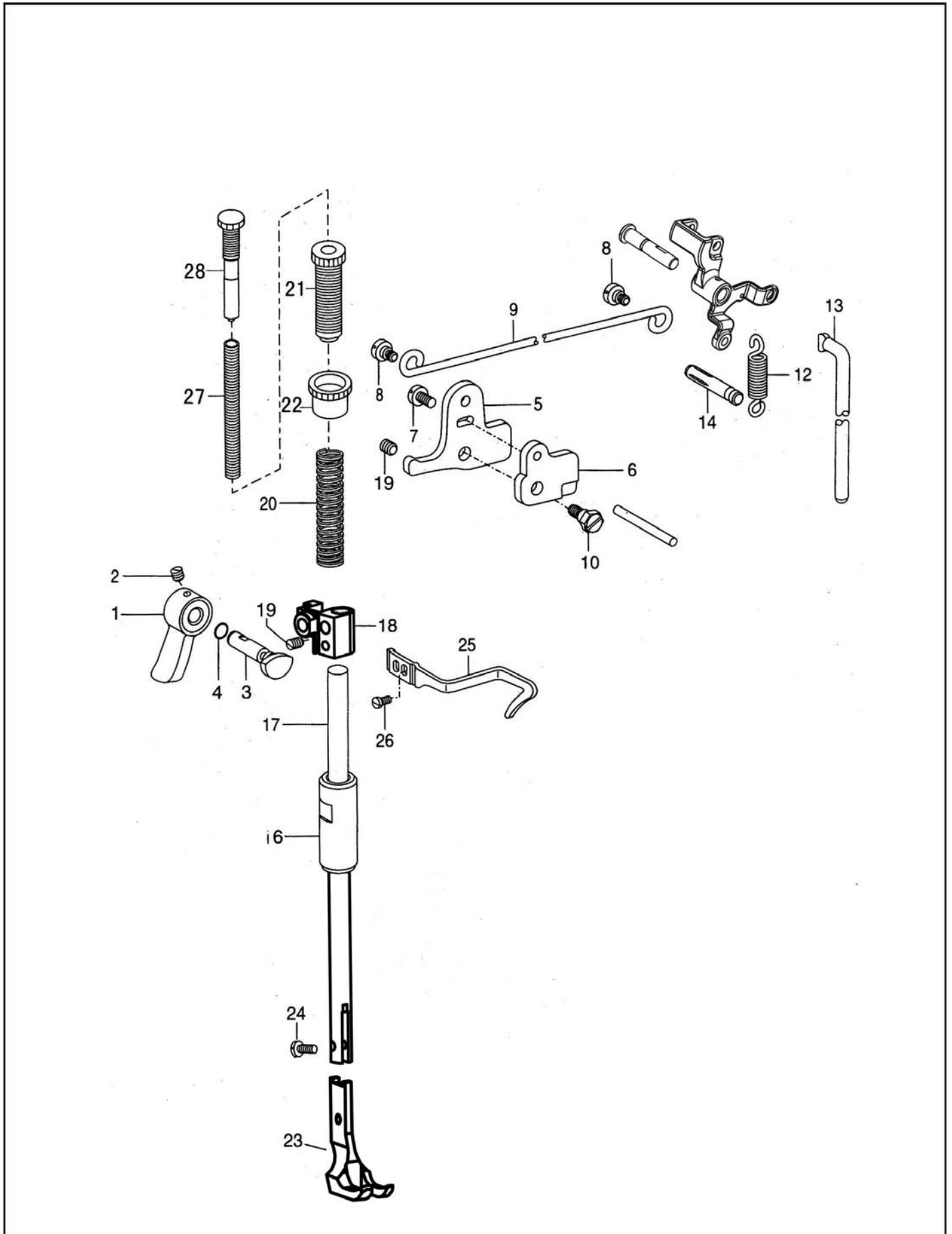

E. 压脚部件 /PRESSER FOOT MACHANISM

零件编号 Parts No.	名称 Description	数量 Quantity	备注 Remarks
C2206-35-1	压脚扳手 Presser bar lifter	1	
C2206-35-2	压脚扳手螺钉 Set screw	1	SM11/64(40)×5
C2206-35-3	压紧杆提升凸轮 Presser bar lifting cam	1	
C2206-35-4	压紧杆提升凸轮 O 型圈 O-ring	1	8×1.9
C2206-35-5	膝控提升杠杆 (左) Scar	1	
C2206-35-6	松线凸轮 Tension releasing cam	1	
C2206-35-7	膝控提升杠杆 (左) 螺钉 Scar	1	SM11/64(40)×6
C2206-35-8	铰链螺钉 Hinge screw	2	SM3/16(28)×3.5
C2206-35-9	膝控提升拉杆 knee lifter rod	1	
C2206-35-10	松线凸轮螺钉 Bolt	1	SM15/64(28)×13
C2206-35-12	膝控提升杠杆 (右) 弹簧 Spring	1	
C2206-35-13	膝控提升连杆 Knee lifter connecting rod	1	
C2206-35-14	弹簧销 Pin for spring	1	
C2206-35-16	压紧杆轴套 Presser bar bushing	1	
C2206-35-17	压紧杆 Presser bar	1	
C2206-35-18	压紧杆导架 Presser bar lifting bracket	1	
C2206-35-19	压紧杆导架螺钉 Set screw	1	SM15/64(28)×7
C2206-35-20	压紧杆弹簧 Presser bar spring	1	
C2206-35-21	调压螺钉 Presser regulating thumb screw	1	SM1/2(28)×43
C2206-35-22	调压螺钉锁紧螺母 Lock nut	1	
C2206-35-23	内压脚 Inner passer	1	
C2206-35-24	压脚螺钉 Set screw	1	SM9/64(40)×11
C2206-35-25	大线勾 Upper thread guide	1	
C2206-35-26	大线勾螺钉 Screw	1	SM11/64(40)×5
C2206-35-27	辅助调压弹簧 Spring	1	
C2206-35-28	辅助调压螺钉 Screw	1	

F. 旋梭部件 / ROTARY HOOK MECHANISM

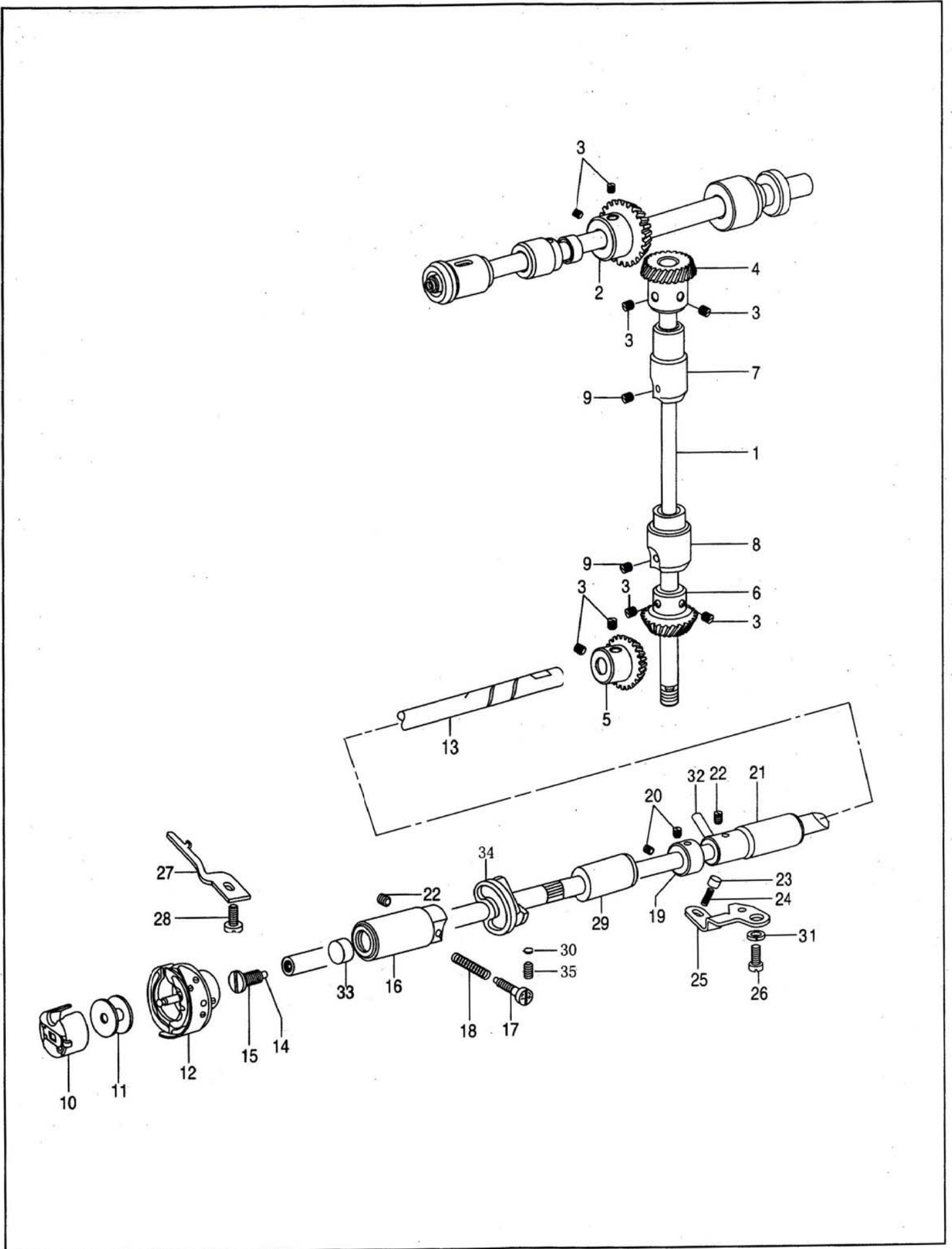

F. 旋梭部件/ROTARY HOOK MECHANISM

零件编号 Parts No.	名称 Description	数量 Quantity	备注 Remarks
C2206-37-1	竖轴 Vertical shaft	1	
C2206-37-2	上轴伞齿轮 Bevel gear for arm shaft	1	
C2206-37-3	伞齿轮螺钉 Set screw	8	
C2206-37-4	竖轴伞齿轮 (上) Bevel gear for vertical shaft (upper)	1	
C2206-37-5	下轴伞齿轮 Bevel gear for hook shaft	1	
C2206-37-6	竖轴伞齿轮 (下) Bevel gear for vertical shaft (lower)	1	
C2206-37-7	竖轴轴套 (上) Vertical shaft bushing (upper)	1	
C2206-37-8	竖轴轴套 (下) Vertical shaft bushing (lower)	1	
C2206-37-9	竖轴轴套螺钉 Set screw	2	
C2206-37-10	梭芯套组件 Bobin case	1	
C2206-37-11	梭芯 Bobin	1	
C2206-37-12	旋梭组件 Rotating hook complete	1	
C2206-37-13	下轴 Rotating hook shaft	1	
C2206-37-14	下轴滤油塞 Filter	1	
C2206-37-15	下轴滤油塞螺钉 Filter screw	1	
C2206-37-16	下轴轴套 (左) Hook shaft bushing (left)	1	
C2206-37-17	油量调节螺钉 Oil adjusting screw	1	
C2206-37-18	油量调节弹簧 Spring for oil adjust	1	
C2206-37-19	下轴紧圈 Collar for hook shaft	1	
C2206-37-20	下轴紧圈螺钉 Set screw	2	
C2206-37-21	下轴轴套 (右) Hook shaft bushing (right)	1	
C2206-37-22	下轴轴套螺钉 Set screw	2	
C2206-37-23	柱塞 Plunger	1	
C2206-37-24	柱塞弹簧 Plunger spring	1	
C2206-37-25	挡板 Guide plate	1	
C2206-37-26	挡板螺钉 Screw	1	
C2206-37-27	旋梭定位勾 Rotating hook sposit snev	1	
C2206-37-28	旋梭定位勾螺钉 Screw	1	
C2206-37-29	下轴轴套 (中) Hook shaft bushing (middle)	2	
C2206-37-30	切线凸轮螺钉垫片 Washer	1	
C2206-37-31	挡板螺钉弹簧垫圈 Washer	1	
C2206-37-32	下轴轴套油管 Oil pipe for hook shaft bushing	1	
C2206-37-33	下轴油封 Oil seal for rotating hook shaft	1	
C2206-37-34	切线凸轮 Thread trimmer carn gear	2	
C2206-37-35	切线凸轮螺钉 Screw	2	

G. 剪线部件 / THREAD TRIMMER MECHANISM

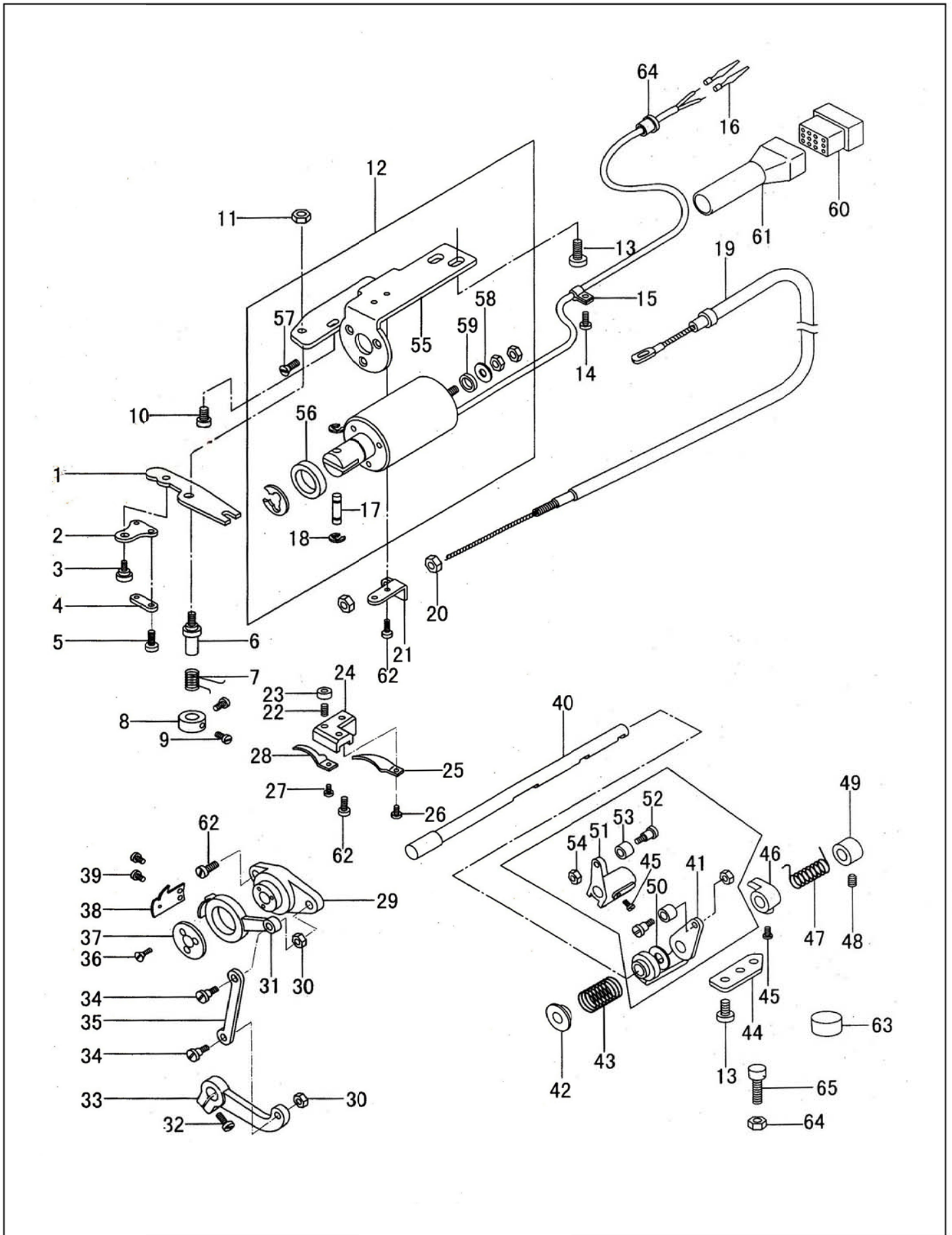

G.剪线部件/THREAD TRIMMER MECHANISM

零件编号 Parts No.	名称 Description	数量 Quantity	备注 Remarks
C2206-39-01	驱动板 Drive plate	1	
C2206-39-02	软线支撑板 Flexible support plate	1	
C2206-39-03	软线支撑板螺钉 Screw	1	
C2206-39-04	软线连板 Flexible connecting plate	1	
C2206-39-05	软线连板螺钉 Screw	1	
C2206-39-06	驱动板轴 Drive plate shaft	1	
C2206-39-07	驱动板弹簧 Drive plate spring	1	
C2206-39-08	驱动板轴紧圈 Drive plate Shaft locking ring	1	
C2206-39-09	驱动板轴紧圈螺钉 Screw	2	
C2206-39-10	安装架连接螺钉 Screw3	1	
C2206-39-11	驱动轴螺母 Nut	1	
C2206-39-12	剪线电磁铁转动组 Thread electromagnet drive asm	1	
C2206-39-13	安装架固定螺钉 Screw	4	
C2206-39-14	线夹螺钉 Screw	1	
C2206-39-15	线夹 Cable clip	1	
C2206-39-16	插头接头 Plug connector	2	
C2206-39-17	剪线电磁铁销 Pin	1	
C2206-39-18	挡圈 Ring	2	
C2206-39-19	松线钢绳组件 Loose thread Steel wire rope asm	1	
C2206-39-20	软线螺母 Nut	2	
C2206-39-21	软线座 The mounting plate	1	
C2206-39-22	定刀座螺钉 Screw	1	
C2206-39-23	定刀座螺母 Nut	1	
C2206-39-24	定刀座 Bracket for fixed blade	1	
C2206-39-25	栏线板 Thread guide	1	
C2206-39-26	栏线板螺钉 Screw	1	
C2206-39-27	定刀片螺钉 Screw	1	
C2206-39-28	定刀片 Fixed blade	1	
C2206-39-29	刀架 Knife holding bracket saddle	1	
C2206-39-30	刀轴连杆螺母 Nut	2	
C2206-39-31	刀架 (左) Knife base (left)	1	
C2206-39-32	驱动曲柄螺钉 Screw	1	
C2206-39-33	剪线电磁铁驱动曲柄 Knife driving crank	1	
C2206-39-34	刀架连杆螺钉 Screw	2	
C2206-39-35	刀架连杆 Link	1	
C2206-39-36	刀架螺钉 Screw	3	
C2206-39-37	刀架垫圈 Washer	1	
C2206-39-38	动刀片 Movable knife	1	
C2206-39-39	动刀片紧固螺钉 Screw	2	
C2206-39-40	凸轮曲柄轴 Knife driving shaft	1	
C2206-39-41	切线凸轮右曲柄 Thread shear cam crank	1	

G. 剪线部件 / THREAD TRIMMER MECHANISM

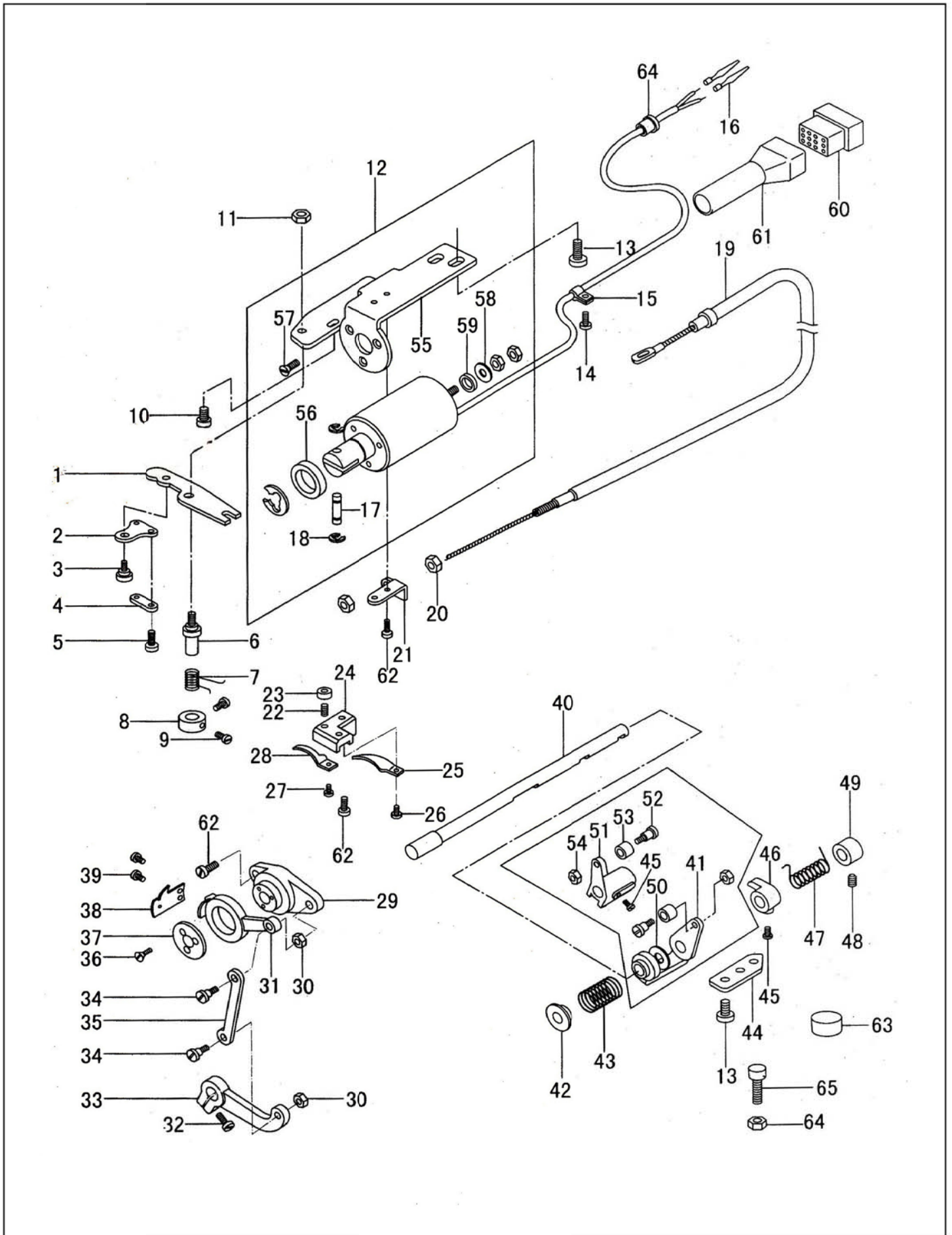

G. 剪线部件/THREAD TRIMMER MECHANISM

零件编号 Parts No.	名称 Description	数量 Quantity	备注 Remarks
C2206-39-42	扭簧端盖 Spring end cover	1	
C2206-39-43	扭簧 Spring	1	
C2206-39-44	止动板 locking plate	1	
C2206-39-45	限位块螺钉 Screw	3	
C2206-39-46	限位块 Stopper	1	
C2206-39-47	凸轮轴扭簧 Spring	1	
C2206-39-48	紧圈螺钉 Screw	2	
C2206-39-49	凸轮轴紧圈 cam retaining ring	1	
C2206-39-50	塑料圈 Washer	1	
C2206-39-51	切线凸轮左曲柄 The tangent cam left crank	1	
C2206-39-52	滚轮螺钉 Screw	2	
C2206-39-53	滚轮 Roller	2	
C2206-39-54	滚轮螺母 Nut	2	
C2206-39-55	剪线电磁铁安装架 Magnetic plug cushion mat	1	
C2206-39-56	密封垫圈（大） Sealing washer(big)	1	
C2206-39-57	剪线电磁铁紧固螺钉 Screw	3	
C2206-39-58	平垫片 Flat gasket	1	
C2206-39-59	密封垫圈（小） Sealing washer(small)	1	
C2206-39-60	插头套 Plug set	1	
C2206-39-61	线罩 Line cover	1	
C2206-39-62	螺钉 Screw	4	
C2206-39-63	缓冲垫 Cushion	1	
C2206-39-64	螺母 Nut	1	
C2206-39-65	止动螺钉 Screw	1	

H. 供油润滑部件 / LUBRICATION

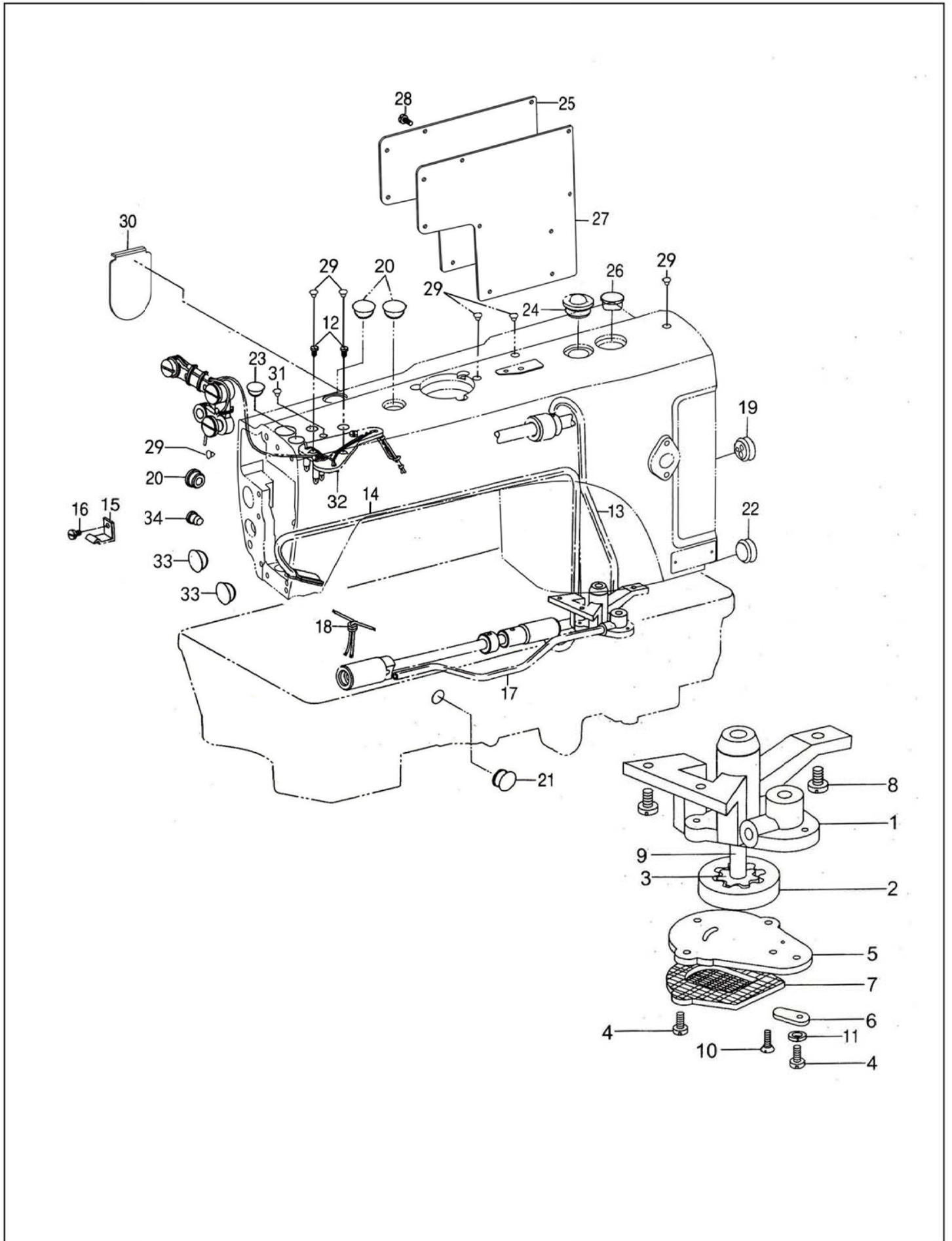

H. 供油润滑部件/LUBRICATION

零件编号 Parts No.	名称 Description	数量 Quantity	备注 Remarks
C2206-43-1	油泵体 Oil pump body	1	
C2206-43-2	油泵大齿轮 Big gear for oil pump	1	
C2206-43-3	油泵小齿轮 Small gear for oil pump	1	
C2206-43-4	油泵调节板螺钉 Screw	3	
C2206-43-5	油泵体盖板 Oil pump felting plate	1	
C2206-43-6	油泵调节板 Adjusting plate for oil pump	1	
C2206-43-7	油泵滤网组件 Oil pump screen complete	1	
C2206-43-8	油泵体螺钉 Screw	3	
C2206-43-9	油泵体短轴 Shaft for oil pump	1	
C2206-43-10	油泵体盖板螺钉 Screw	2	
C2206-43-11	弹簧垫圈 spring washer	1	
C2206-43-12	油线固定板螺钉 Screw	2	
C2206-43-13	上轴油管组件 Oil pipe for arm shaft	1	
C2206-43-14	回油管组件 Oil return pipe asm	1	
C2206-43-15	回油管夹 Oil return pipe clamp	1	
C2206-43-16	回油管夹螺钉 Screw	1	
C2206-43-17	下轴油管组件 Oil pipe for hook shaft	1	
C2206-43-18	油线 Oil wick	1	
C2206-43-19	三孔过线橡皮塞 (ø16) Rubber plug(ø16)	1	
C2206-43-20	橡皮塞 (ø18) Rubber plug(ø18)	3	
C2206-43-21	橡皮塞 (ø8.8) Rubber plug(ø8.8)	1	
C2206-43-22	橡皮塞 (ø27) Rubber plug(ø27)	1	
C2206-43-23	橡皮塞 (ø11) Rubber plug(ø11)	1	
C2206-43-24	油窗组件 Oil sight window asm	1	
C2206-43-25	后窗板 Side plate	1	
C2206-43-26	橡皮塞 (ø25) Rubber plug(ø25)	1	
C2206-43-27	后窗板密封垫片 Gasket	1	
C2206-43-28	后窗板螺钉 Screw	8	
C2206-43-29	橡皮塞 (ø8) Rubber plug(ø8)	6	
C2206-43-30	小挡油板 Keep off plate	1	
C2206-43-31	橡皮塞 (ø5.7) Rubber plug(ø5.7)	1	
C2206-43-32	油线固定板大组件 Oil wick set plate complete	1	
C2206-43-33	面板橡皮塞 (ø11.8) Rubber plug(ø11.8)	2	

I. 倒缝部件 / REVERSE FEED COMPONENTS

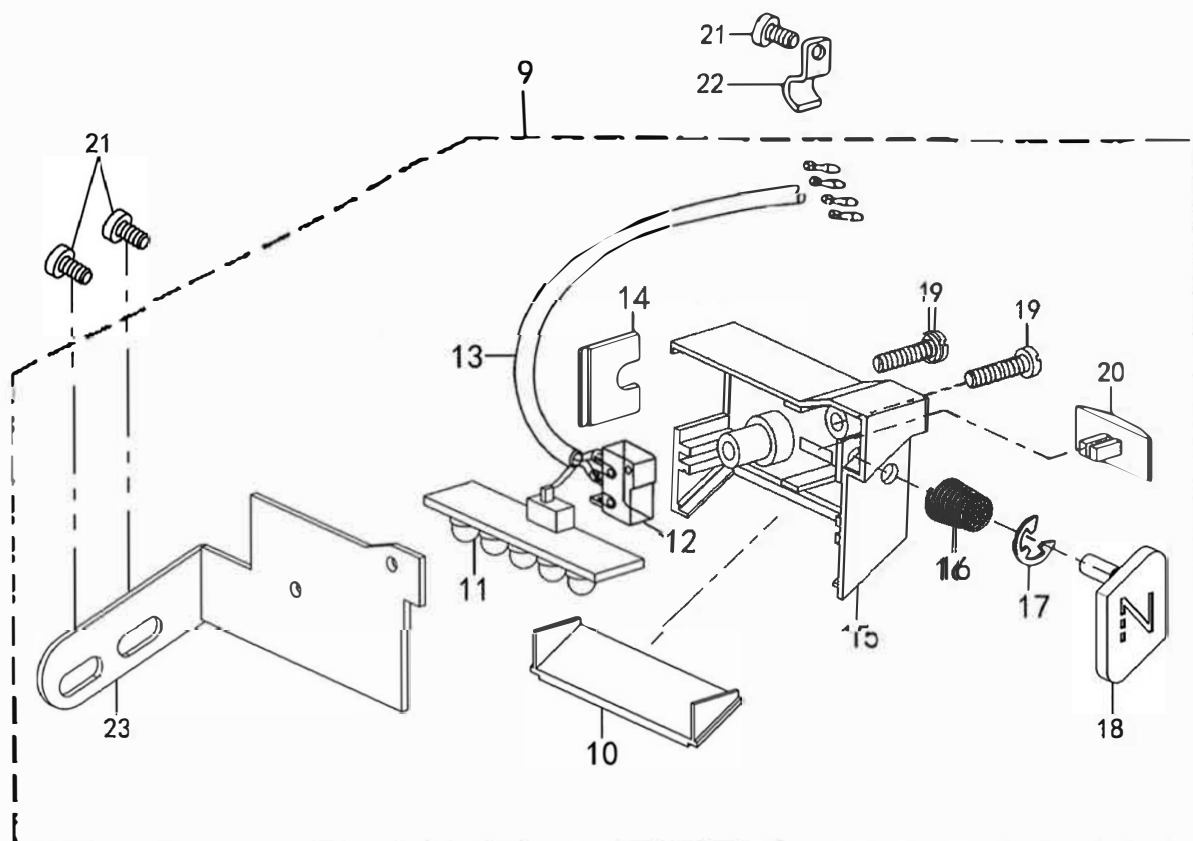
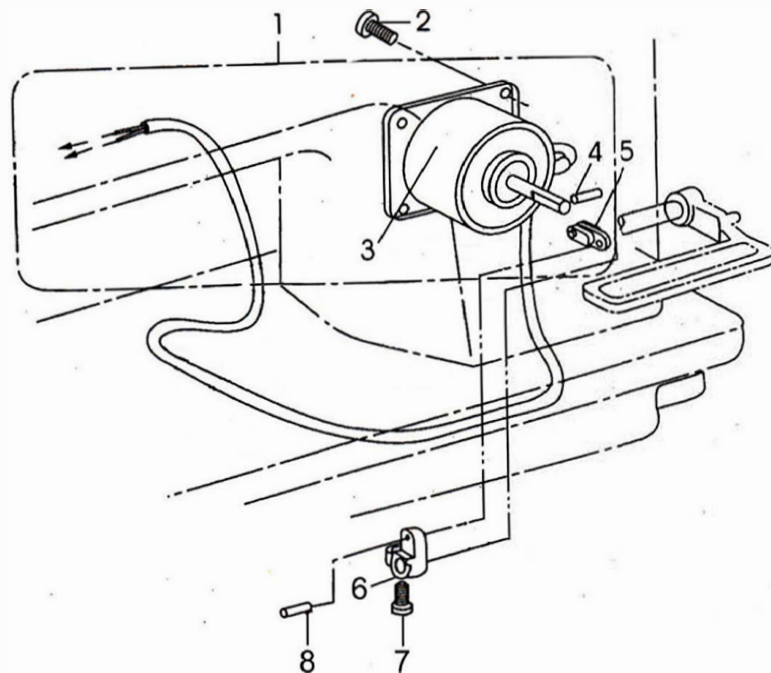

I. 倒缝部件/REVERSE FEED COMPONENTS

零件编号 Parts No.	名称 Description	数量 Quantity	备注 Remarks
C2206-45-1	倒缝电磁铁组件 Reverse feed magnet assy	1	
C2206-45-2	电磁铁连接螺钉 Screw	4	
C2206-45-3	倒缝电磁铁 Reverse feed magnet	1	
C2206-45-4	连杆销 Connecting rod pin		
C2206-45-5	连杆 Connecting rod	2	
C2206-45-6	曲柄 Crank	1	
C2206-45-7	曲柄螺钉 Screw	1	
C2206-45-8	曲柄销 Crank pin	1	
C2206-45-9	倒缝开关灯组件 Reverse feed switch assy	1	
C2206-45-10	有机玻璃 Organic glass	1	
C2206-45-11	灯 lamp	1	
C2206-45-12	倒缝电磁铁开关触件 Switch contact member	1	
C2206-45-13	开关导线 Reverse feed switch wire	1	
C2206-45-14	卡线板 Card line board	1	
C2206-45-15	开关盒 Switch Box	1	
C2206-45-16	弹簧 Spring	1	
C2206-45-17	开口卡簧 E-ring	1	
C2206-45-18	倒缝按键开关 Key switch	1	
C2206-45-19	螺钉 Screw	1	
C2206-45-20	灯开关 Light switch	1	
C2206-45-21	螺钉 Screw	3	
C2206-45-22	线夹 Clamps	1	
C2206-45-23	倒缝电磁铁开关安装架 Switch mounting bracket	1	

J. 内置式自动抬压脚机构/INBUILT FOOT LIFT STRUCTURE

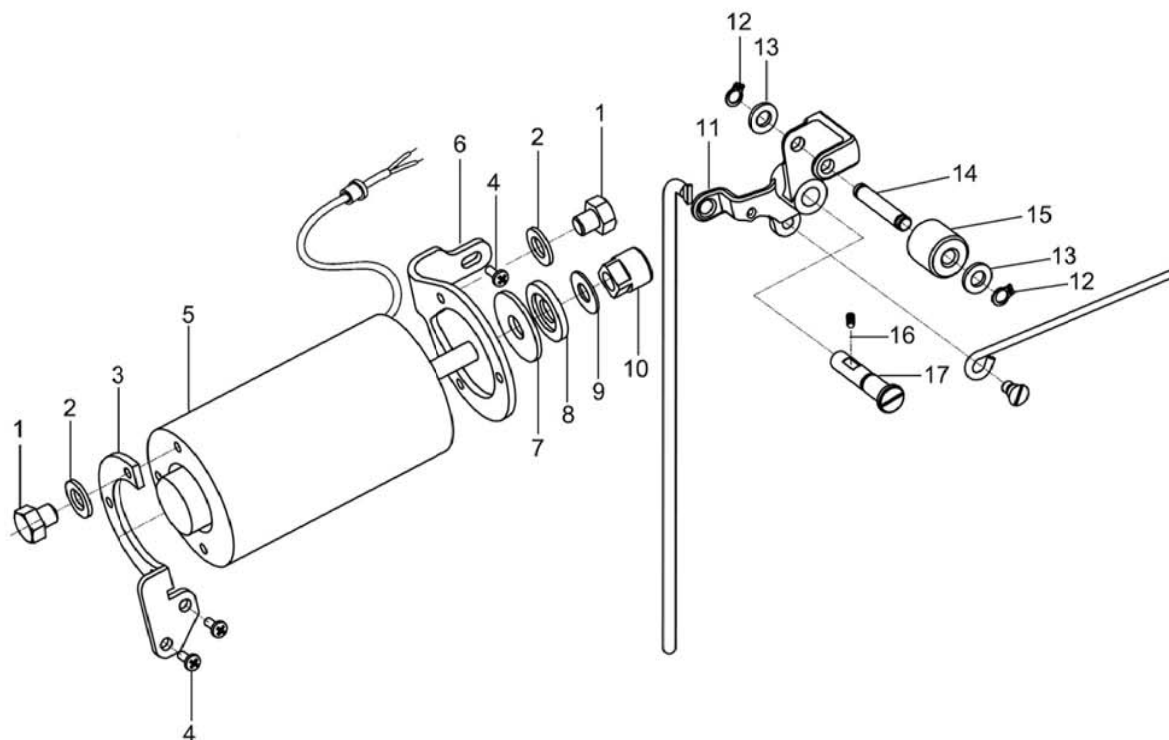

K. 一体式电控系统 IMPACT CONTROLLER SYSTEM

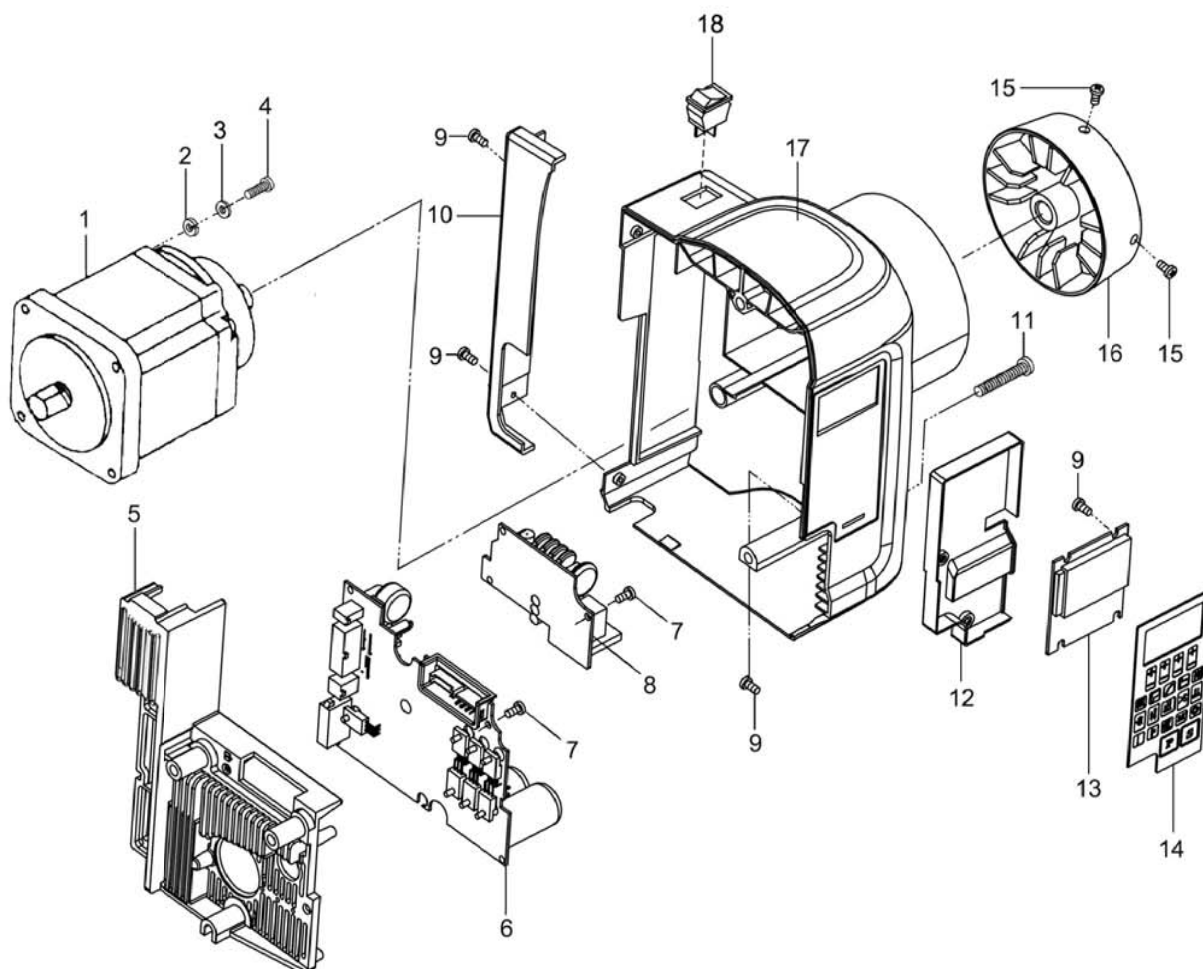

J. 内置式自动抬压脚机构/INBUILT FOOT LIFT STRUCTURE

零件编号 Parts No.	名称 Description	数量 Quantity	备注 Remarks
C2206-47-1	六角螺钉 Bolt	6	
C2206-47-2	弹簧垫片 Spring gasket	6	
C2206-47-3	抬压脚电磁铁支撑架左 Left carriage	1	
C2206-47-4	十字螺钉 Screw 3/16x28 L=9	3	
C2206-47-5	抬压脚电磁铁 Foot lift electromagnet	1	
C2206-47-6	抬压脚电磁铁支撑架右 Right carriage	1	
C2206-47-7	缓冲垫 A Rubber cushion A	1	
C2206-47-8	缓冲垫 B Rubber cushion B	1	
C2206-47-9	垫片 Washer	1	
C2206-47-10	顶柱 Top column	1	
C2206-47-11	自动抬压脚后杠杆 Auto foot lift after lever	1	
C2206-47-12	C型卡簧 C5 Retaining ring external	2	
C2206-47-13	垫片 Washer	2	
C2206-47-14	尼龙滚柱销 Nylon roller pin	1	
C2206-47-15	尼龙滚柱 Nylon rollers	1	
C2206-47-16	紧固螺钉 Set screw	1	
C2206-47-17	杠杆销 Lever pin	1	

K. 一体式电控系统/IMPACT CONTROLLER SYSTEM

C2206-47-1	750W 伺服电机 Motor asm	1	
C2206-47-2	弹簧垫片 Spring gasket	4	
C2206-47-3	平垫片 gasket	4	
C2206-47-4	内六角螺钉 Socket head screw	4	
C2206-47-5	电控散热板 Heat sink	1	
C2206-47-6	控制箱主板 Circuit board	1	
C2206-47-7	十字组合螺钉 M4X8 Cross recess head screw	7	
C2206-47-8	控制箱电源板 power panel	1	
C2206-47-9	自攻螺钉 ST2.9X6.5	7	
C2206-47-10	后盖板 Back shroud	1	
C2206-47-11	罩壳连接螺钉 Casing connection screws	4	
C2206-47-12	绝缘挡板 Insulating barrier	1	
C2206-47-13	控制箱数显小板 Digital display small plate	1	
C2206-47-14	控制箱操作面膜 Operating the mask	1	
C2206-47-15	主动轮螺钉 Set screw	2	
C2206-47-16	主动轮 Balance wheel	1	
C2206-47-17	电机罩壳 The motor housings	1	
C2206-47-18	电控开关 Electric control switch	1	

L. 附件 / ACCESSORIES

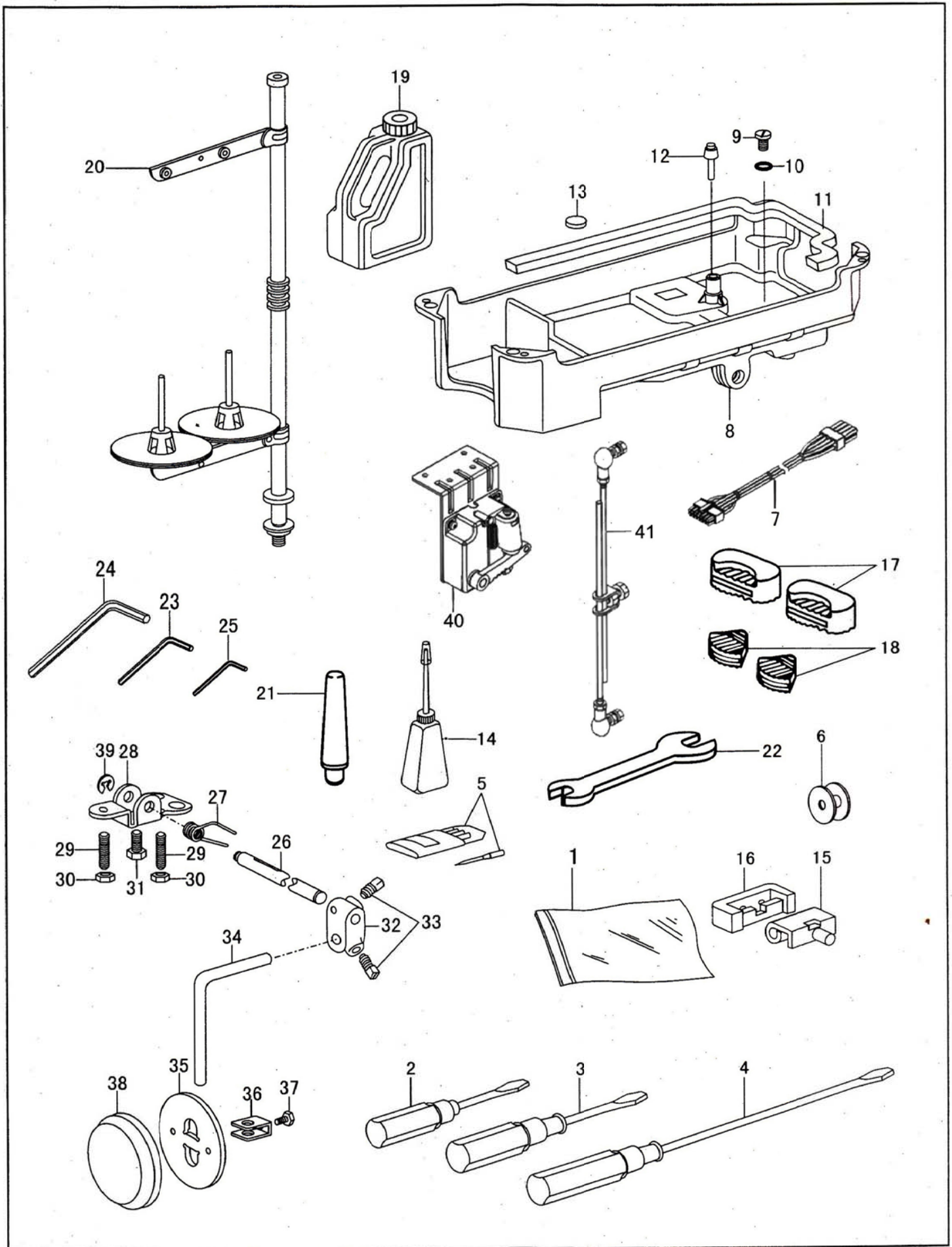

L. 附件 / ACCESSORIES

零件编号 Parts No.	名称 Description	数量 Quantity	备注 Remarks
C2206-49- 1	零件袋 parts bag	1	
C2206-49- 2	一字开刀 (小) Screw driver(small)	1	
C2206-49- 3	一字开刀 (中) Screw driver(middle)	1	
C2206-49- 4	一字开刀 (大) Screw driver(large)	1	
C2206-49- 5	机针 Needle	4	
C2206-49- 6	梭芯 Bobbin	3	
C2206-49- 7	电源线 The power cord	1	
C2206-49- 8	油盘 Oil reservoir	1	
C2206-49- 9	放油螺钉 Screw	1	
C2206-49- 10	放油螺钉垫圈 Washer	1	
C2206-49- 11	油盘垫 Gasket	2	
C2206-49- 12	膝控提升顶杆 Knee press lifter rod	1	
C2206-49- 13	磁块 Magnet	1	
C2206-49- 14	油壶 Oil pot	1	
C2206-49- 15	机壳铰链 Hinge	2	
C2206-49- 16	机壳铰链套 Rubber coat	2	
C2206-49- 17	机头防震垫块 (大) Cushion(big)	2	
C2206-49- 18	机头防震垫块 (小) Cushion(small)	2	
C2206-49- 19	油箱 Oil tank	1	
C2206-49- 20	线架组件 Spool stand complete	1	
C2206-49- 21	机头撑杆 Frame support bar	1	
C2206-49- 22	呆扳手 spanner	1	
C2206-49- 23	2mm 内六角扳手 2mm cross screw driver	1	
C2206-49- 24	3mm 内六角扳手 3mm cross screw driver	1	
C2206-49-25	2.5mm 内六角扳手 2.5mm cross screw driver	1	
C2206-49- 26	膝控铰链轴 Hinge pin	1	
C2206-49- 27	膝控复位弹簧 Spring	1	
C2206-49- 28	膝控限位架 Knee lifter stop bracket	1	
C2206-49- 29	膝控限位调节螺钉 Screw	2	
C2206-49- 30	调节螺母 Nut	2	
C2206-49- 31	膝控限位架螺钉 Screw	1	
C2206-49- 32	碰块弯杆接头 Connector	1	
C2206-49- 33	碰块弯杆接头螺钉 Screw	4	
C2206-49- 34	膝控碰块弯杆 Bent rod	1	
C2206-49- 35	膝控碰块 Bell	1	
C2206-49- 36	碰块架 Bell bracket	1	
C2206-49- 37	碰块架螺钉 Screw	1	
C2206-49- 38	碰块垫 Knee pan plate cover	1	
C2206-49- 39	开口挡圈 Split stop ring	1	
C2206-49- 40	电控脚踏 Electric control pedal	1	
C2206-49- 41	脚踏连杆 Pedal connecting rod	1	

CONSEW Since 1898®

2206RB-14-7DD
PARTS BOOK
and
INSTRUCTION MANUAL
Revised

CONSEW USA

© Consew 2020