

INSTRUCTION MANUAL

MINI WALKING FOOT
SEWING MACHINE

& PARTS LIST

CONSEW®



CONTENTS

Preface	
Speed of machine	1
Oiling	1
Needle	2
Thread	2
Winding the bobbin	3
Threading the machine and needle	4
Prepare for sewing	5
To start sewing	5
To regulate the length of stitch	6
Reverse sewing	6
Tensions	7
Adjusting the Bobbin Case	8
To remove the hook and clean the race	9
Instructions to repair machine	10
Constructional drawing	11
External group	12
External group parts list	13
Sewing transmission group	14
Sewing transmission group parts list	15
Shuttle transmission group	16
Shuttle transmission group parts list	17
Feed transmission group	18
Feed transmission group parts list	19
Driving & reversing mechanism group	20
Driving & reversing mechanism group parts list	21
Electric power & dynamic transmission	22
Electric power & dynatransmission group parts list	23
Zig Zag mechanism group	24
Zig Zag mechanism group parts list	25

PREFACE

This semi-industrial sewing machine makes a single needle lock stitch and is equipped with a high lifting, independent upper and lower feed mechanism. It is intended for stitching medium, heavy, and extra heavy cloth, canvas, upholstery materials and light leather.

This Mini-Walking Foot sewing machine's feeding mechanism is composed of upper and lower feed dogs which are synchronized to feed the material either forward or reverse. Both lifting and feeding feet alternatively press the material tightly together, permitting even stitching.

Remark : This instruction manual is commonly applied to our series of mini walking foot sewing machine, which refers to straight sewing model and zig zag sewing model.

SPEED OF MACHINE

The maximum speed recommended for this machine is 900 RPM or "stitches per minute". Use regular house-hold circuit 115 Volts, 60 HZ. The machine is equipped with a one tenth (1/10) HP motor with reduction pulley to provide good power at the recommended speed.

This sewing machine can be mounted on a commercial stand. To do so, requires a special cut-out table top, a one inch (1") diameter pulley, a special Balance Wheel Item No. 11, and a maximum 1725 RPM motor.

OILING

Before operating, oil all "metal to metal" working parts, and at the places indicated. Use only genuine sewing machine oil. Operate the machine briefly on scrap material after oiling to prevent soiling the work. Frequent oiling is recommended.

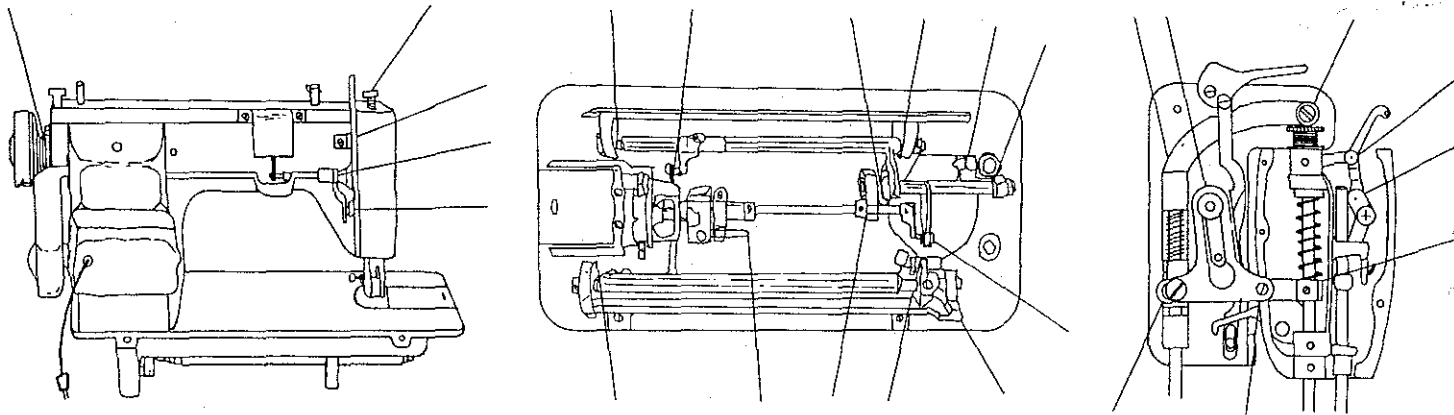

NEEDLE

Use 135x17 needles size 18 to 23. Use size 22 for most medium to heavy sewing.

Install needle as illustrated.

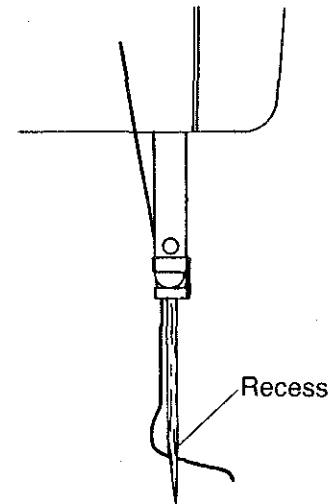

THREAD

To obtain the best results with your sewing machine, we recommend size 69 Bonded Nylon Thread.

WINDING THE BOBBIN

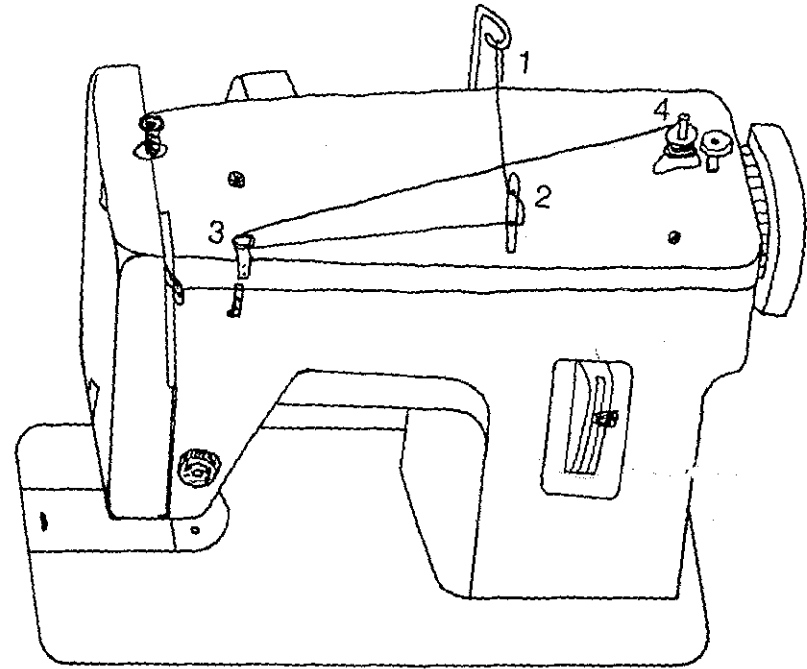
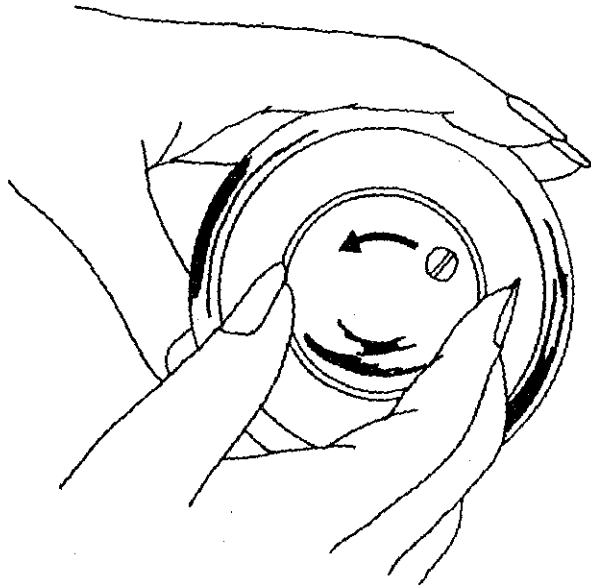

THREADING THE MACHINE AND NEEDLE

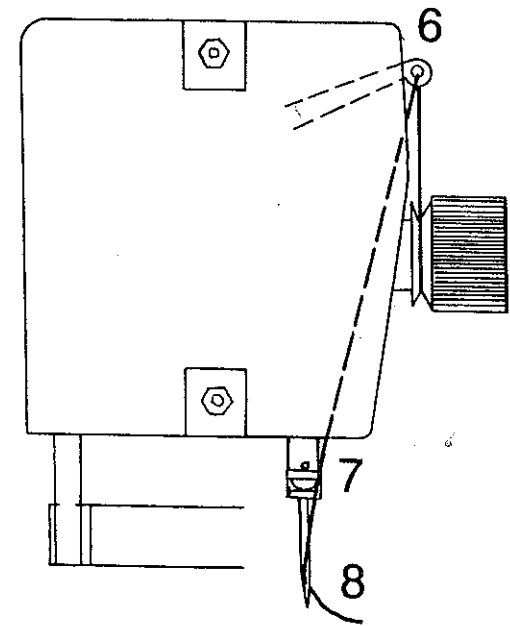
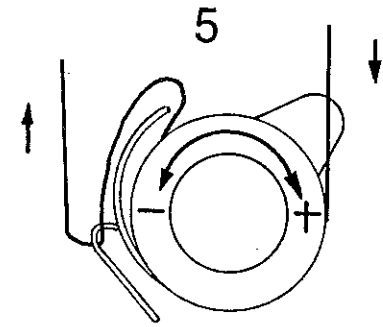
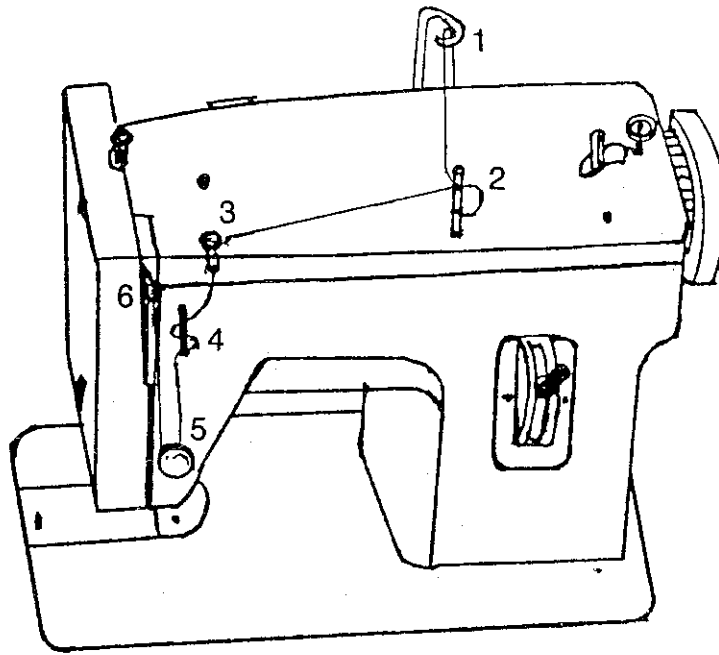

PREPARE FOR SEWING

Thread the machine. Then pick up the bobbin thread as follows:

- (1) While holding the loose end of the needle thread in your left hand, turn the balance wheel toward you by hand until the needle moves down and up again to its highest point.
- (2) Pull the needle thread gently, and the bobbin thread will come up with it in the form of a loop through the needle hole.
- (3) With your finger, pull this loop until the end of the thread appears. If the bobbin thread does not rise, check to see if at least 5 or 6 inches of bobbin thread is hanging loosely from the bobbin case.

TO START SEWING

- (1) With the needle raised, lay the lower or bobbin thread straight back from the needle hole.
- (2) Place the material to be sewn under the presser feet and lower them onto the material.
- (3) Hold the upper or needle thread (threaded through the eye of the needle) with the fingers of the left hand. Turn the balance wheel toward you with your right hand until the outside presser foot reaches its most backward position.
- (4) Now operate the knee or foot control to start sewing.

The above procedure is necessary so the motor will start the machine to sewing. Do not help the feeding of the machine by hand, as this may bend or break the needle. Also, damage to the hook can occur.

The machine may run a little slow when it's new. However, it will begin to "free up" and run smoothly with continued use.

During operation, the balance wheel of the machine always turns toward the operator. To avoid tangled thread and jamming of the sewing hook, do not turn the balance wheel backward (away from the operator).

WARNING: Never operate the machine without material under the presser feet. Your machine will probably "lock" and cannot be operated until the thread is cleaned out of the hook race.

TO REGULATE THE LENGTH OF STITCH

Most sewing will be done with the maximum stitch length. However, the length of the stitch can be adjusted as follows:

- (1) Loosen the thumb nut on the stitch length lever.
- (2) Raise the stitch length (feed regulator) lever until the desired stitch length is obtained.
- (3) Tighten the thumb nut.

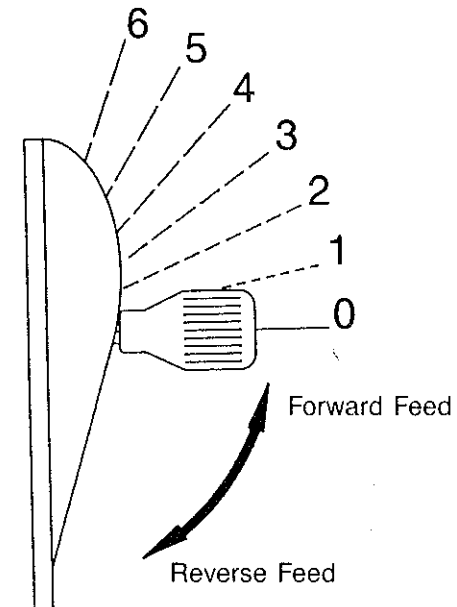

REVERSE SEWING

To sew in reverse:

- (1) Lower the feed regulator (stitch length) lever all the way to the bottom of the slot in the stitch length plate.
- (2) Hold the lever there until reverse sewing is completed.
- (3) Then return the lever to the forward position.

Adjusting the Bobbin Case

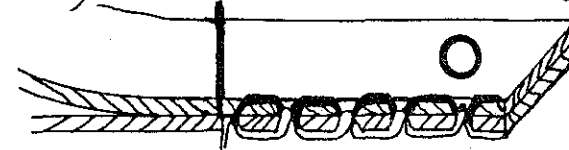
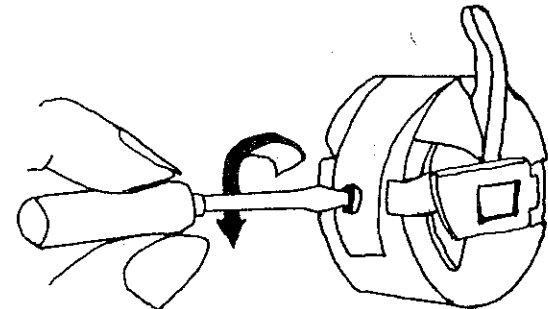
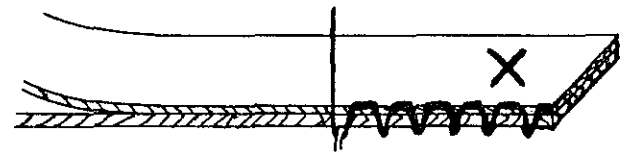
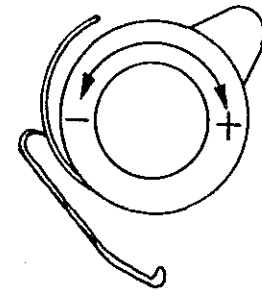
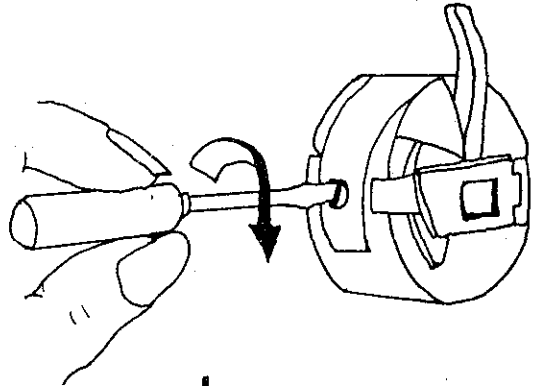
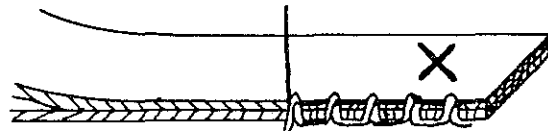
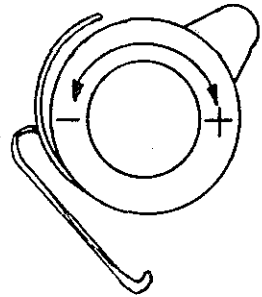

TO REMOVE THE HOOK AND CLEAN THE RACE

DO NOT FORCE ANY OF THESE OPERATIONS

- (1) Turn the balance wheel by hand until the needle is at its highest point.
- (2) Remove the bobbin and bobbin case.
- (3) Turn knob (A) one half turn toward you.
- (4) Turn knob (B) one half turn away from you.
- (5) Remove retaining ring (C) and hook (D) by grasping the axle of the hook.
- (6) Remove accumulated lint and thread from the retaining ring, hook, and race body.
- (7) Replace hook (D) in race body with the axle facing out, forming a perfect circle with the driver (E).
- (8) Replace retaining ring (C), polished side out, so that both pins are under knobs (A) and (B).
- (9) Lock the retaining ring knobs (A) and (B).
- (10) Replace bobbin and bobbin case, and resume sewing.

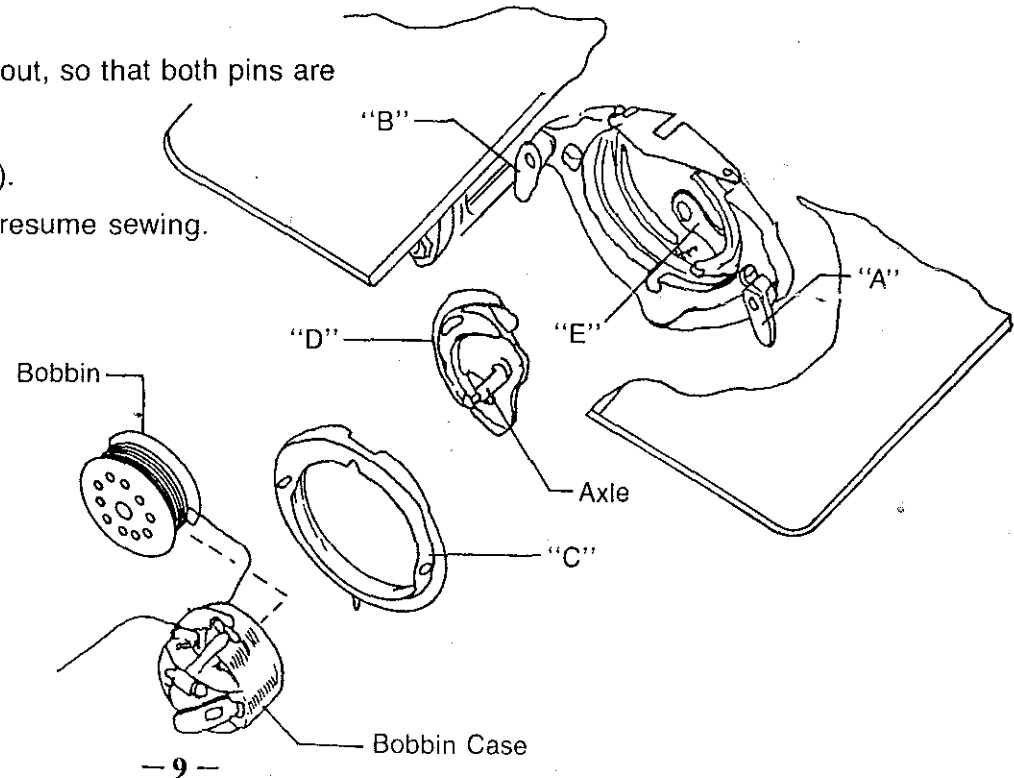

INSTRUCTIONS TO REPAIR MACHINE SHOULD THE BALANCE WHEEL AND MOTOR RUN BUT THE MACHINE WILL NOT SEW

- (1) Remove clutch stop screw.
- (2) Remove hand clutch screw.
- (3) Notice position of prongs on clutch washer in slot of balance wheel bushing.
- (4) Remove clutch washer and make 1/2 turn and replace.
- (5) Screw in hand clutch screw very tight
- (6) Screw in stop screw.
- (7) Back off on hand clutch screw.
- (8) Run motor and check to see if balance wheel turns freely without running the machine.
- (9) Tighten hand clutch screw and the machine should run properly.

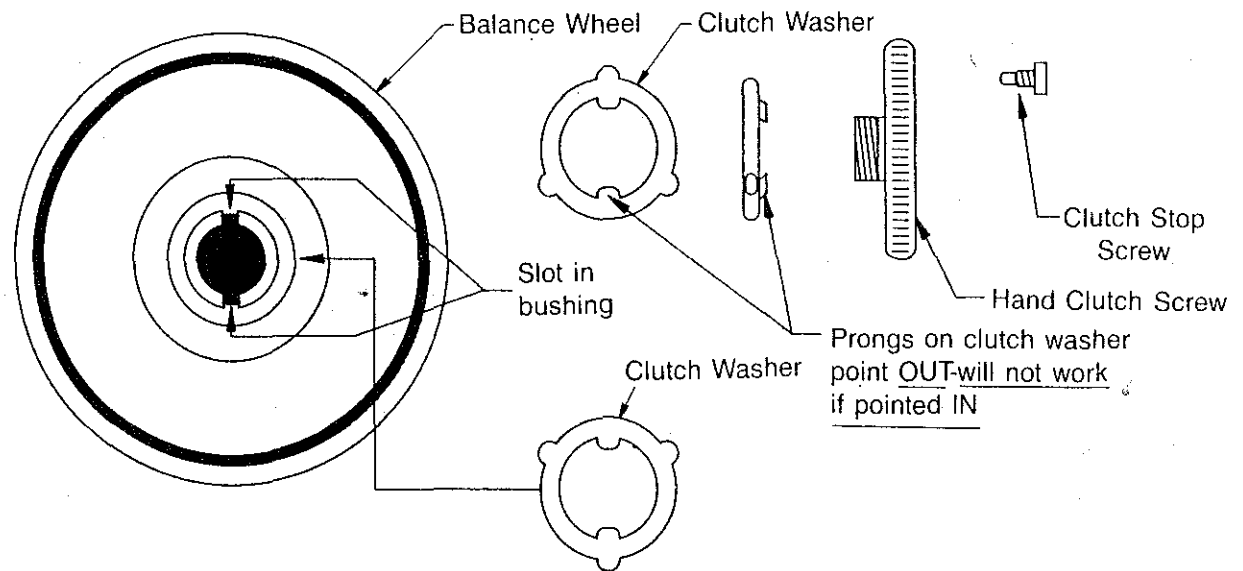

CONSTRUCTIONAL

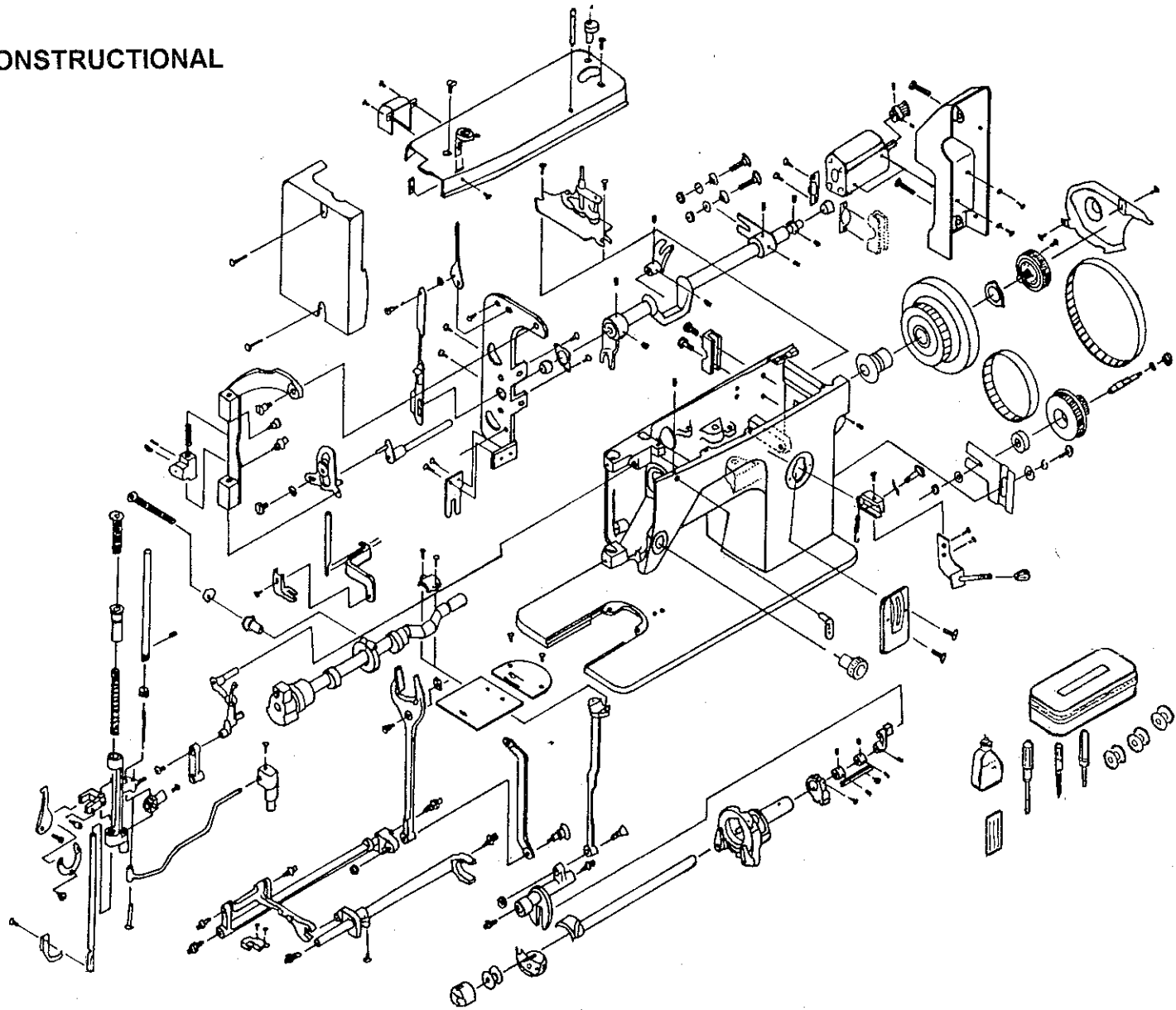

GROUP 1 CONSTRUCTION EXTERNAL GROUP

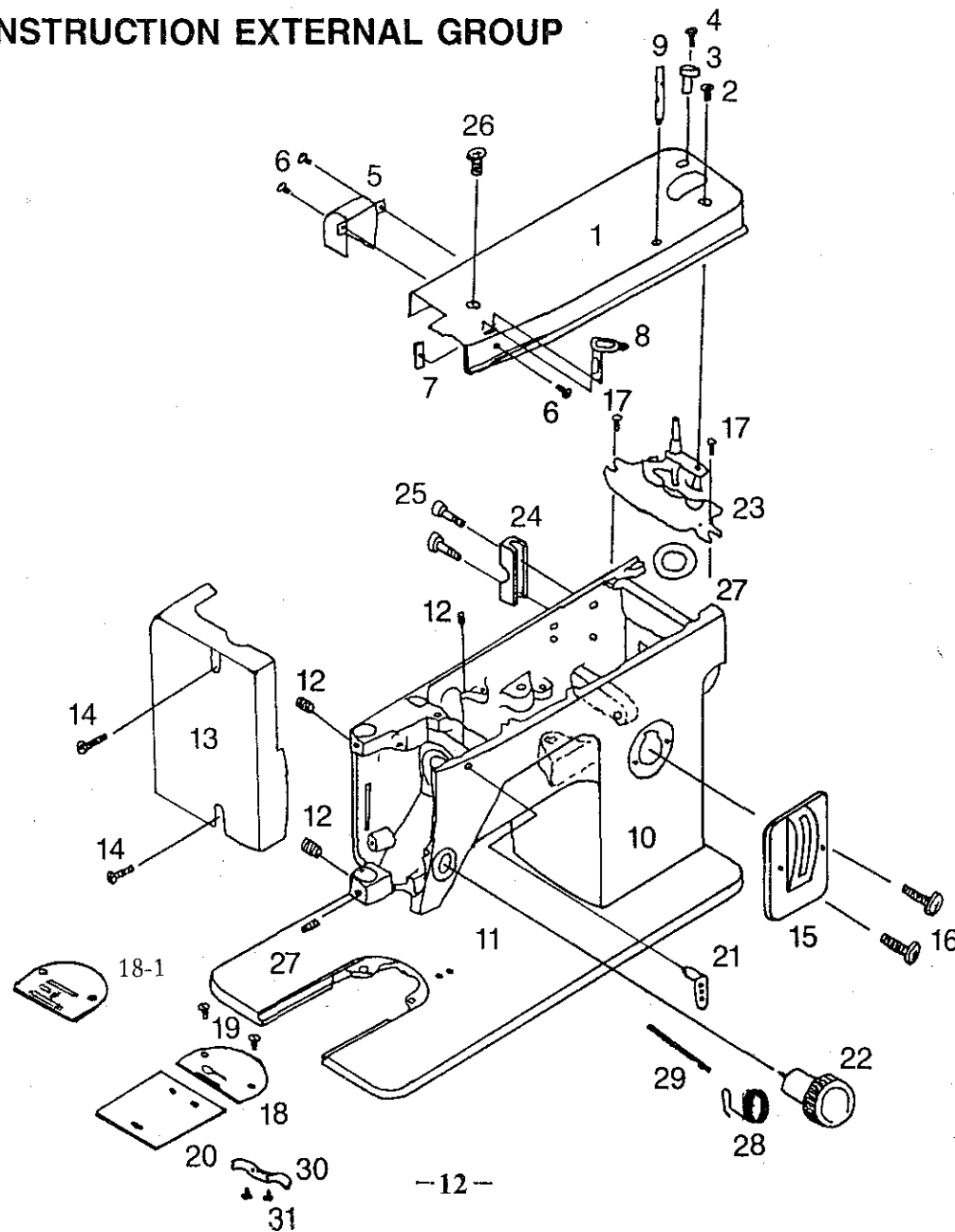

GROUP 1

KEY NO.	PART NO.	PART NAME	Q'TY
1	W047	TOP PLATE	1
2	B071	TOP PLATE SET SCREW	1
3	E066	BOBBIN WINDER STOPPER	1
4	E066-2	BOBBIN WINDER STOPPER SET SCREW	1
5	W047-1	SMALL PLATE COVER	1
6	A092	SMALL PLATE COVER SET SCREW BOBBIN WINDER ASSEMBLY SET SCREW	2 1
7	E070-1	BOBBIN WINDER TENSION ASSEMBLY SET NUT	1
8	E070	BOBBIN WINDER TENSION ASSEMBLY	1
9	W047-2	SPOOL PIN	1
10	W001	ARM BODY	1
11	W002	BED	1
12	D097	NEEDLE BAR SUPPORT SET SCREW THREE HOLE THREAD GUIDE SET SCREW	2 1
13	W048	FACE PLATE	1
14	C097	FACE PLATE SET SCREW	2
15	W125	STITCH LENGTH PLATE	1

16	A075	STITCH LENGTH PLATE SET SCREW	1
17	B010	BOBBIN WINDER SET SCREW	2
18	W032	NEEDLE PLATE	1
19	A052	NEEDLE PLATE SET SCREW	2
20	A048-B	SHUTTLE RACE SLIDE	1
21	W029	THREE HOLE THREAD GUIDE	1
22	W184-1	DIAL TENSION ASSEMBLY	1
23	W030	BOBBIN WINDER	1
24	W025	CRANK ROD BEARING SET BASE	1
25	W025-1	CRANK ROD BEARING SET BASE SET SCREW	2
26	E072	TOP PLATE SET SCREW	1
27	A117	BOBBIN WINDER RUBBER RING	1
28	W184-3	THREAD TAKE-UP/CHECK-SPRING	1
29	W184-2	TENSION RELEASE PIN	1
30	A049	SHUTTLE RACE SLIDE SPRING	1
31	A050	SHUTTLE RACE SLIDE SPRING SET SCREW	1
18-1	W032-1	ZIG ZAG NEEDLE PLATE	1

GROUP 2 SEWING TRANSMISSION GROUP

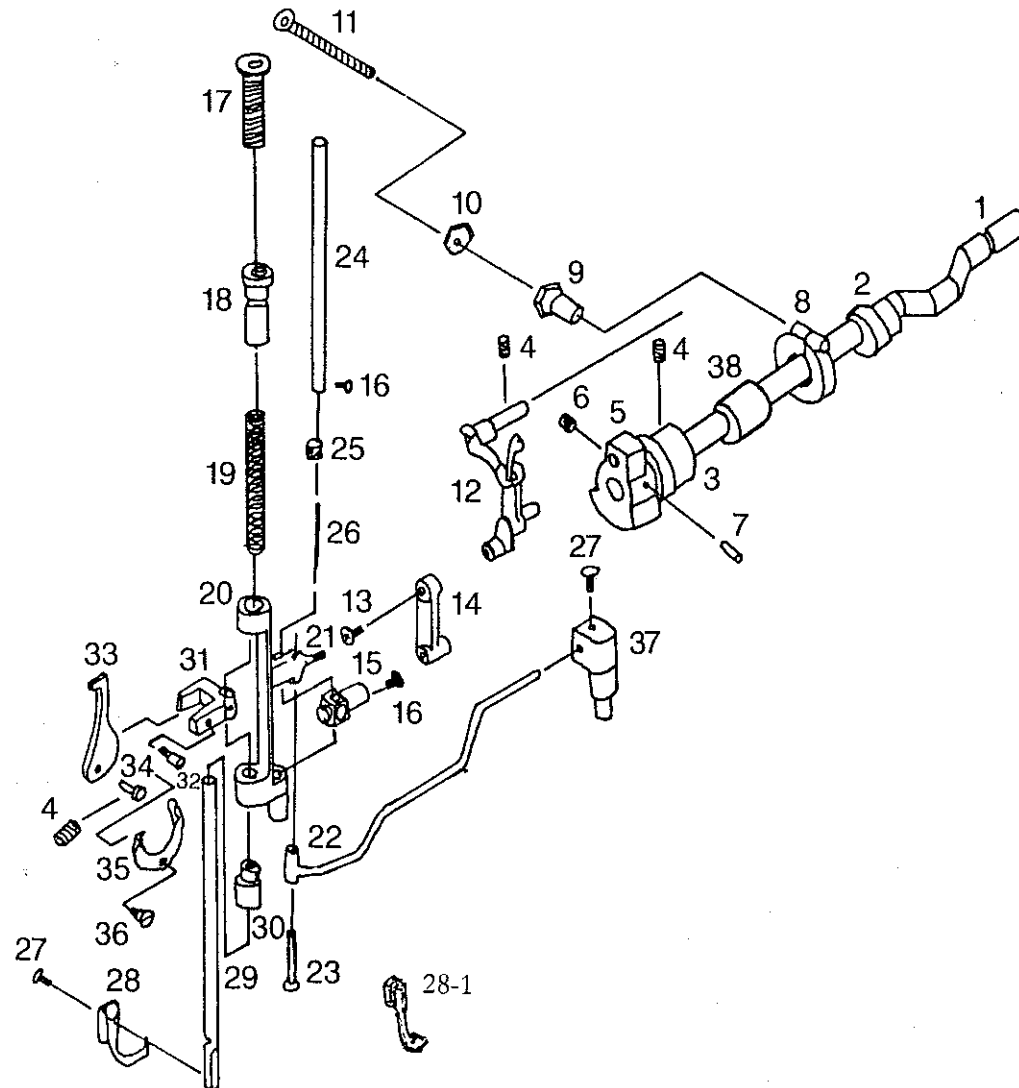

GROUP 2

KEY NO.	PART NO.	PART NAME	Q'TY
1	E053	ARM SHAFT	1
2	B007	FEED CAM	2
3	B051	ARM SHAFT BUSHING	1
4	A012	THREAD TAKE-UP ASSEMBLY SET SCREW	1
		ARM SHAFT BUSHING SET SCREW	1
		TENSION RELEASE LEVER DRAG LINK PIN SET SCREW	1
5	B048	THREAD TAKE-UP LEVER CAM	1
6	A029	THREAD TAKE-UP ASSEMBLY SET SCREW	1
7	E048-1	THREAD TAKE-UP LEVER CAM SET PIN	1
8	W028-4	CRANK ROD LEVER CAM FOLLOWER	1
9	W028-2	CRANK ROD LEVER CAM FOLLOWER ADJUST NUT	1
10	W028-3	CRANK ROD LEVER CAM FOLLOWER LOCK SCREW	1
11	W028-1	CRANK ROD LEVER CAM FOLLOWER LOCK NUT	1
12	E020	THREAD TAKE-UP ASSEMBLY	1
13	E020-2	NEEDLE BAR CONNECTING ROD SET SCREW	1
14	B018	NEEDLE BAR CONNECTING ROD	1
15	A042	NEEDLE BAR CONNECTING STUD	1
16	A092	NEEDLE SET SCREW	1
17	A031	PRESSER REGULATING THUMB SCREW	1
18	W010	PRESSER REGULATING THUMB SET SCREW	1
19	A032	PRESSER BAR SPRING	1
20	B016	NEEDLE BAR SUPPORT	1

21	A021	NEEDLE BAR CONNECTING JOINT SET SCREW	1
22	W015	ZIGZAG CONNECTING ROD	1
23	B099	NEEDLE BAR CONNECTING JOINT PIN	1
24	W066	NEEDLE BAR	1
25	W067	NEEDLE THREAD GUIDE	1
26	W008	NEEDLE	1
27	A036	PRESSER FOOT SET SCREW	1
28	W012	INSIDE PRESSER FOOT	1
29	A035-1	PRESSER BAR	1
30	B028	PRESSER BAR LOWER BUSHING	1
31	W039	PRESSER BAR BARCKET	1
32	A046	PRESSER BAR ACTUATOR GUIDE SCREW	1
33	W043	TENSION RELEASE LEVER DRAG LINK	1
34	D020	TENSION RELEASE LEVER DRAG LINK SET PIN	1
35	W045	TENSION RELEASE LEVER	1
36	B046	TENSION RELEASE LEVER SET SCREW	1
37	W016	ZIGZAG CONNECTING ROD SET BASE	1
38	W065	PRESSER BAR ACTUATOR "CAM"	1
28-1	B043-1	ZIG ZAG PRESSER FOOT	1

GROUP 3 SHUTTLE TRANSMISSION GROUP

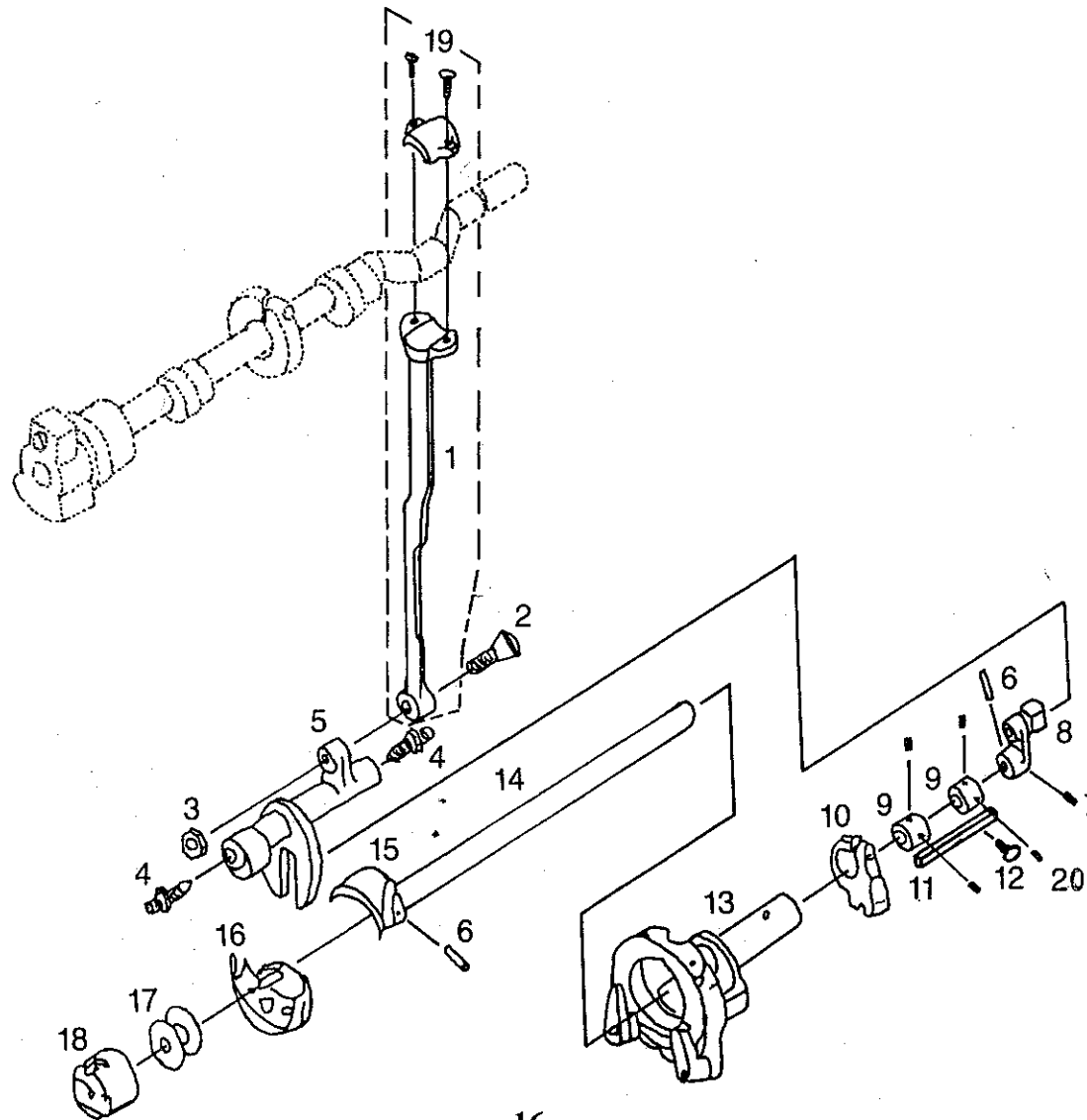

GROUP 3

KEY NO.	PART NO.	PART NAME	Q'TY
1	B139	CRANK CONNECTING ROD	1
2	A027A	CRANK CONNECTING ROD SET SCREW	1
3	A027B	CRANK CONNECTING ROD SET NUT	1
4	A023	OSCILLATING SHAFT SET SCREW & NUT	2
5	A024	OSCILLATING SHAFT	1
6	A018	SHUTTLE DRIVER PIN OSCILLATING SHAFT CRANK SET PIN	1 1
7	A021	OSCILLATING SHAFT CRANK SET SCREW	1
8	B179	OSCILLATING SHAFT CRANK WITH SLIDE BLOCK	1
9	B177	LOWER SHAFT COLLAR	2
10	B155	SHUTTLE RACE GUIDE	1
11	A084	SHUTTLE RACE GUIDE SHAFT	1
12	B153	SHUTTLE RACE GUIDE SHAFT SET SCREW	1
13	B170	SHUTTLE RACE GUIDE SHAFT COMPLETE	1
14	B172	LOWER SHAFT	1
15	W172	SHUTTLE DRIVER	1
16	D099	SHUTTLE HOOK	1
17	A107	BOBBIN	1
18	D100	BOBBIN CASE ASSEMBLY	1
19	B139-2	CRANK CONNECTING ROD CAP SET SCREW	2
20	B177-1	LOWER SHAFT COLLAR SET SCREW	4

GROUP 4 FEED TRANSMISSION GROUP

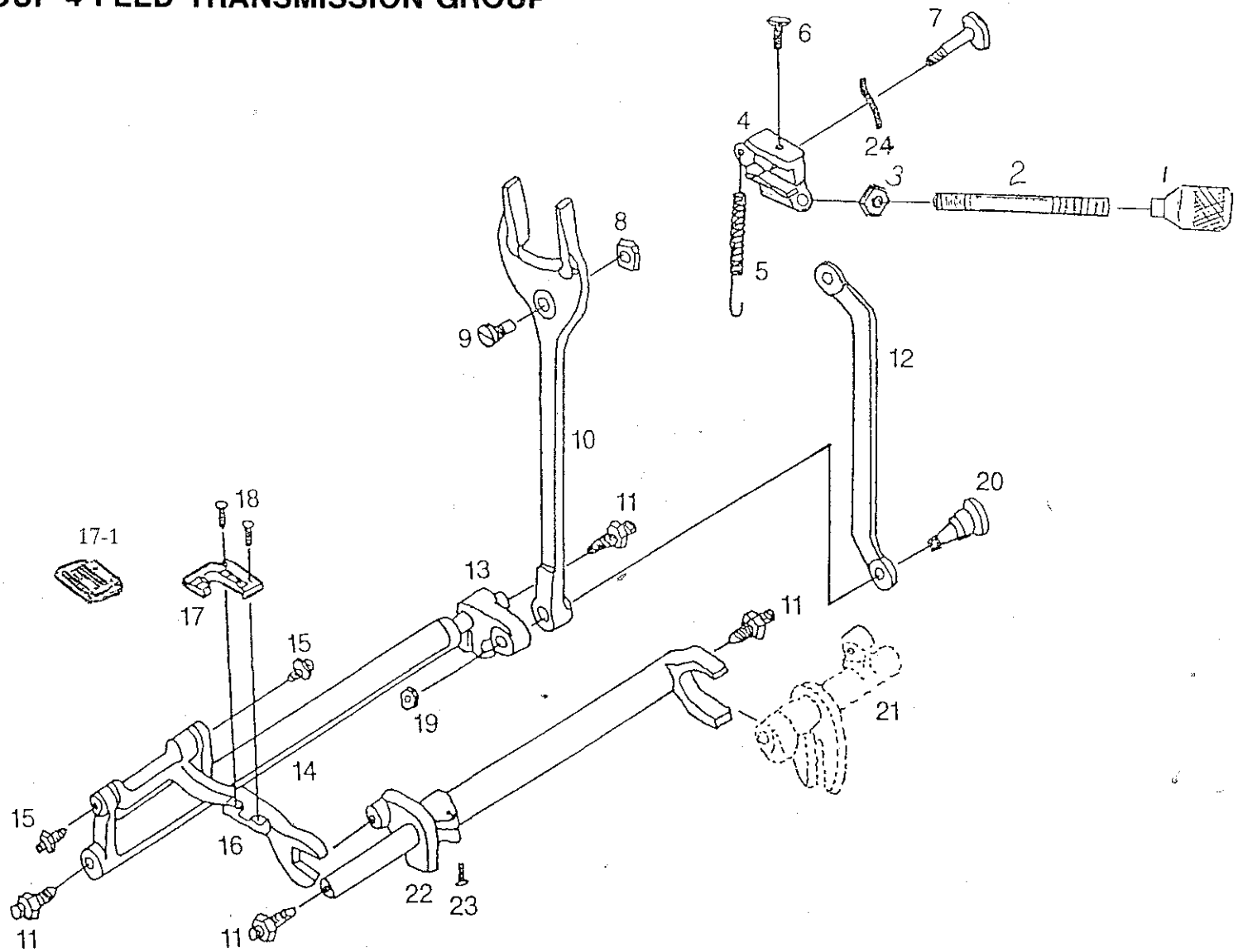

GROUP 4

KEY NO.	PART NO.	PART NAME	Q'TY
1	W109	FEED REGULATOR THUMB NUT	1
2	W105	FEED REGULATOR LEVER	1
3	A053B-2	FEED REGULATOR LEVER NUT	1
4	W107	FEED REGULATOR	1
5	W106	FEED REGULATOR SPRING	1
6	B010	FEED REGULATOR SCREW SET SCREW	1
7	W108	FEED REGULATOR SCREW	1
8	A069B	FEED CONNECTION SLIDE BLOCK	1
9	A069A	FEED CONNECTION SLIDE BLOCK STUD	1
10	B103	FORKED ROD	1
11	A023	FEED ROCK SHAFT CENTER SCREW & NUT FEED LIFTING ROCK SHAFT SCREW & NUT	2 2
12	W046	DRIVING CRANK	1
13	A071B	FEED ROCK SHAFT CRANK	1
14	A071A	FEED ROCK SHAFT	1
15	A076	FEED BAR CENTER SCREW & NUT	2
16	A075	FEED BAR	1
17	W011	FEED DOG	1
18	A078	FEED DOG SCREW	2
19	W046-1	DRIVING CRANK GUIDE NUT	1
20	A061	DRIVING CRANK GUIDE SCREW	1
21	A072	FEED LIFTING ROCK SHAFT	1
22	A073	FEED LIFTING ROCK SHAFT CRANK	1
23	A071B-1	FEED ROCK SHAFT CRANK SET SCREW FEED LIFTING ROCK SHAFT CRANK SET SCREW	2
24	A067	FEED REGULATOR SCREW WASHER	1
17-1	W011-1	ZIG ZAG FEED DOG	1

GROUP 5 DRIVING & REVERSING MECHANISM GROUP

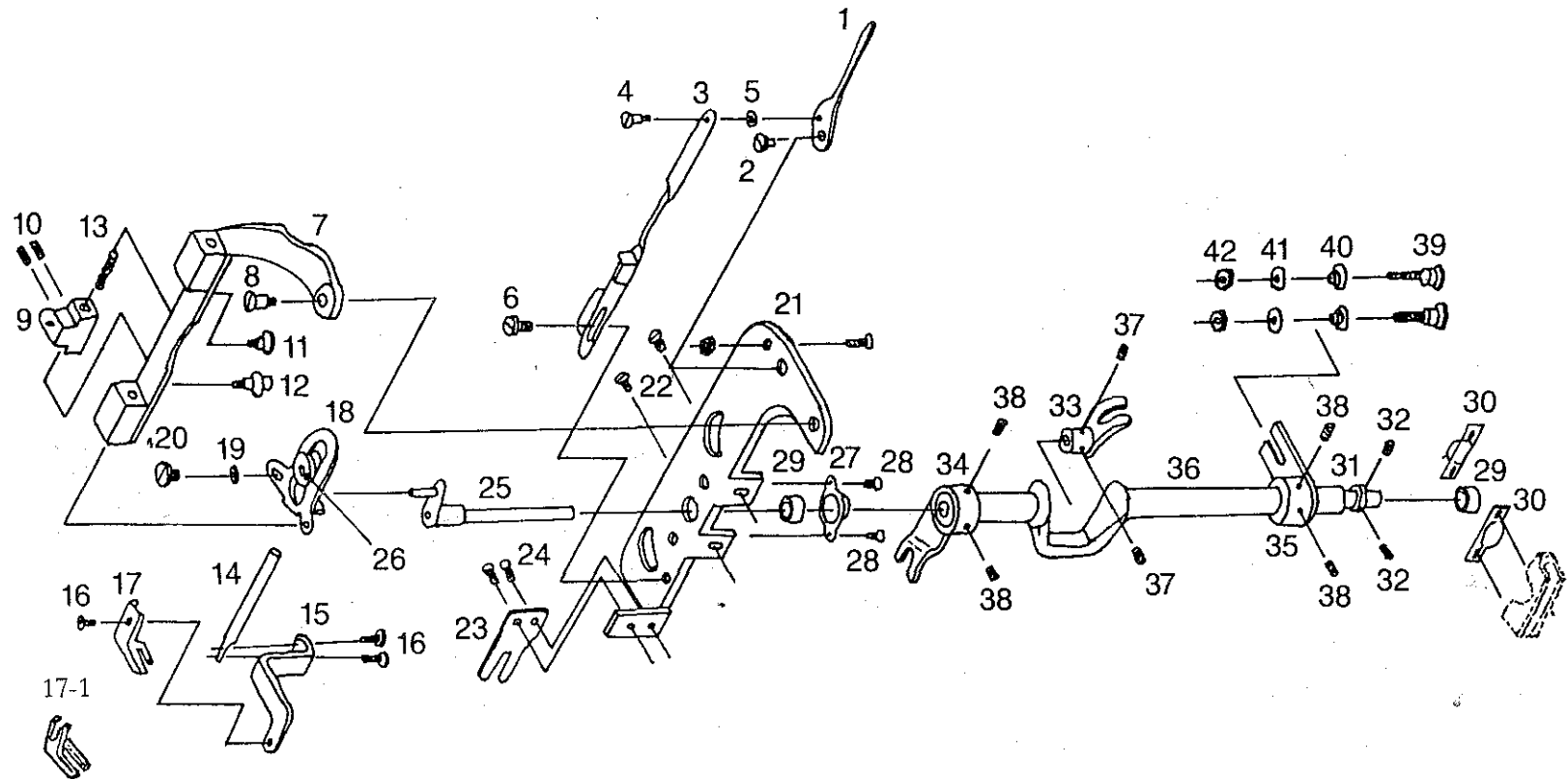

GROUP 5

KEY NO.	PART NO.	PART NAME	Q'TY
1	W042	PRESSER BAR LIFTER	1
2	W042-3	PRESSER BAR LIFTER HINGE SCREW	1
3	W026	LIFT BAR	1
4	W042-2	UPPER LIFT BAR SCREW	1
5	W042-1	SPACER	1
6	W026-1	LIFT BAR GUIDE SCREW	1
7	W018	PRESSER BAR TRACK	1
8	W018-1	PRESSER BAR TRACK HINGE SCREW	1
9	W020	REAR PRESSER BAR BRACKET	1
10	A029	REAR PRESSER BAR SET SCREW	2
11	W018-2	PRESSER BAR TRACK GUIDE SCREW	1
12	W018-3	PRESSER BAR TRACK FEED STUD	1
13	W019-1	PRESSER BAR LOAD SPRING (REAR)	1
14	W019	REAR PRESSER BAR	1
15	W017	OUTSIDE PRESSER FOOT BRACKET	1
16	B010	OUTSIDE PRESSER FOOT BRACKET SCREW	2
		OUTSIDE PRESSER FOOT SET SCREW	1
17	W013	OUTSIDE PRESSER FOOT	1
18	W024	PRESSER BAR ACTUATOR	1
19	W020-2	FEED SCREW RING	1
20	W020-1	PRESSER BAR ACTUATOR FEED SCREW	1
21	W041	END PLATE	1
22	W041-1	END PLATE SET SCREW	2
23	W014	OUTSIDE PRESSER FOOT BRACKET LIMITATOR	1
24	C097	BRACKET LIMITATOR SET SCREW	2
25	W036	PRESSER BAR FEED ROD	1

26	W024-1	PRESSER BAR ACTUATOR SPACER	1
27	W022	END PLATE BEARING SET PLATE	1
28	W041-2	REVET	3
29	W021	BEARING BRACKET BUSHING	2
30	W023	LIFT CRANK ROD BEARING BRACKET PLATE	2
31	W052	ROCKER END SET RING	1
32	W052-1	ROCKER SET RING SET SCREW	2
33	W033	PRESSER BAR ACTUATOR UP-DOWN ROCKER	1
34	W034	PRESSER BAR ACTUATOR FEED ROCKER	1
35	W035	CRANK ROD ROCKER	1
36	W053	CRANK ROD	1
37	D097	PRESSER BAR ACTUATOR UP-DOWN ROCKER SET SCREW	2
38	W034-3	CRANK ROD ROCKER SET SCREW	2
		PRESSER BAR FEED ROCKER SET SCREW	2
39	W046-2	CRANK ROD ROCKER GUIDE SCREW	1
		UP-DOWN ROCKER GUIDE SCREW	1
40	W046-3	CRANK ROD ROCKER LOCK SPACER	1
		UP-DOWN ROCKER LOCK SPACER	1
41	W046-4	CRANK ROD ROCKER LOCK WASHER	1
		UP-DOWN ROCKER LOCK WASHER	1
42	A061-B	CRANK ROD ROCKER LOCK NUT	1
		UP-DOWN ROCKER LOCK NUT	1
17-1	W013-1	ZIG ZAG OUTSIDE PRESSER FOOT	1

GROUP 6 ELECTRIC POWER & DYNAMIC TRANSMISSION

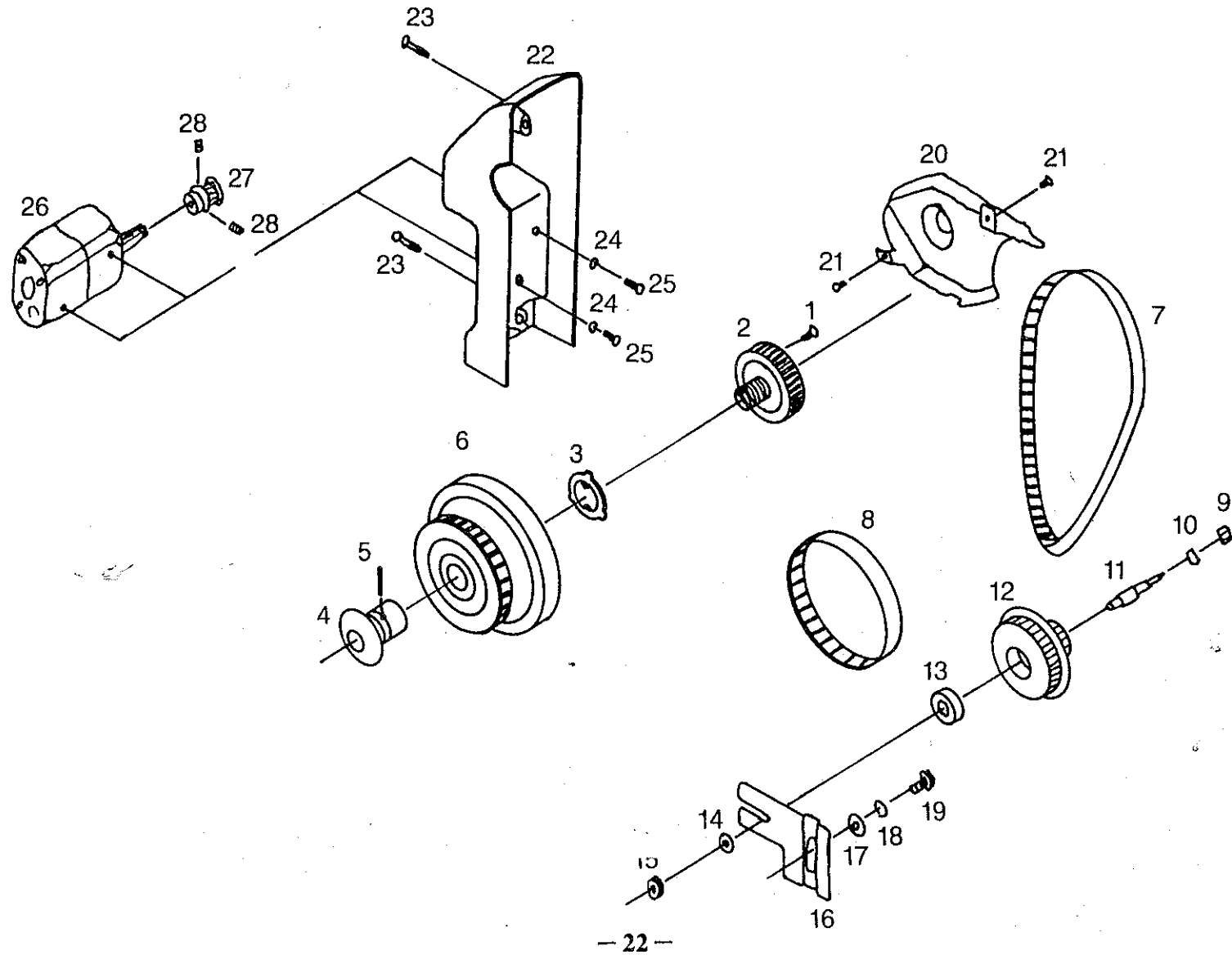

GROUP 6

KEY NO.	PART NO.	PART NAME	QTY
1	A004	STOP MOTION CLAMP STOP SCREW	1
2	A002-1	STOP MOTION CLAMP SCREW	1
3	A005	STOP MOTION CLAMP WASHER	1
4	A003	BLANCE WHEEL BUSHING	1
5	A006	BLANCE WHEEL BUSHING SET PIN	1
6	W060	HAND WHEEL	1
7	W006	BELT (130XL0.18)	1
8	W007	BELT (80XL0.25)	1
9	D116	E5 RING	1
10	W061-5	IDLE PULLEY SHAFT WASHER	1
11	W061-1	IDLE PULLEY SHAFT	1
12	W061-3	IDLE PULLEY	1
13	W061-4	IDLE PULLEY BEARING	1
14	W061-6	IDLE PULLEY LOCK WASHER	1
15	W061-2	IDLE PULLEY SET NUT	1
16	W059	PULLEY BRACKET	1
17	LT-2M-4	MOTOR BRACKET SET WASHER	1
18	LT-2M-3	MOTOR BRACKET SET LOCK WASHER	1
19	LT-2M-2	MOTOR BRACKET SET SCREW	1
20	W050	BELT COVER	1
21	A092	BELT COVER SET SCREW	2
22	W049	MOTOR BASE (REAR COVER)	1
23	W049-1	MOTOR BASE SET SCREW	2
24	W049-2	MOTOR SET WASHER	2
25	C097	MOTOR SET SCREW	2
26	W003	MOTOR	1
27	W062-1	MOTOR PULLEY	1
28	D097	MOTOR PULLEY SET SCREW	2

GROUP 7 ZIG ZAG MACHANISM GROUP

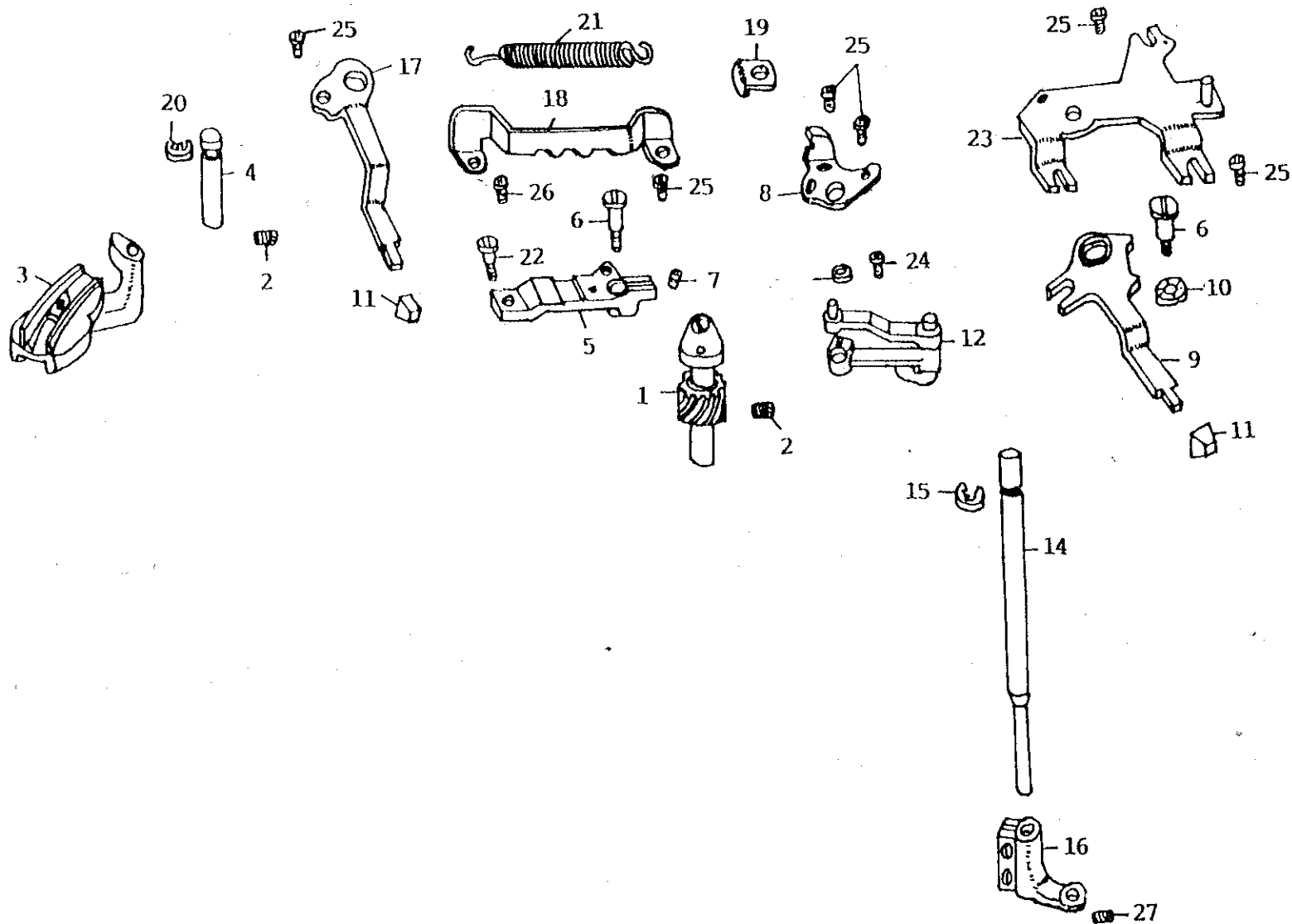

GROUP 7

KEY NO.	PART NO.	PART NAME	Q'TY
1	703	ZIG ZAG CAM & GEAR (ASSEMBLY)	1
2	704	SET SCREW (3) FOR NO. 703, 707	2
3	705-2	NEEDLE DISPLACEMENT REGULATOR (ASSEMBLY)	1
4	707	SHAFT FOR NO. 705-2	1
5	708	ZIG ZAG WIDTH REGULATOR	1
6	709	ZIG ZAG WIDTH REGULATOR PIN (2) FOR NO. 708, M712	2
7	710	SET SCREW FOR NO. 708(1)	1
8	M711	ZIG ZAG CONNECTING PLATE	1
9	M712	ZIG ZAG REGULATING LEVER	1
10	718	SPRING WASHER FOR NO. 709	1
11	D720	ZIG ZAG WIDTH LEVER KNOB (2)	2
12	725	ZIG ZAG CONNECTING LINK SLIDE BLOCK (ASSEMBLY)	1
13	725-7	COLLAR FOR NO. 725	1
14	M726	ZIG ZAG VERTICAL SHAFT	1
15	727	SNAP RING FOR NO. M726 (1)	1
16	728	ZIG ZAG VERTICAL SHAFT ARM	1
17	M729	NEEDLE POSITION COMPLETE LEVER	1
18	M732	CLIK STOPER FOR NO. M729	1
19	M734	NEEDLE POSITION COMPLETE LEVER GUIDE	1
20	741	SNAP RING (2) FOR NO. 707	1
21	N746	SPRING FOR NO. M711	1
22	C749	ZIG ZAG REGULATING LEVER PIN	1
23	H777	ZIG ZAG CONTROL PLATE	1
24	412-1	SET SCREW FOR NO. 725 (1)	1
25	154	SET SCREW FOR NO. M711(2), M729(1), M732(1), N747(1), H777(2)	7
26	110-1	SET SCREW FOR NO. M732(1)	1
27	402	SET SCREW FOR NO. 728(1)	1