



867-M Standard

Teileliste und Näheinrichtungen
Parts List and Sewing Equipment

Alle Rechte vorbehalten.

Eigentum der Dürkopp Adler AG und urheberrechtlich geschützt. Jede Wiederverwendung dieser Inhalte, auch in Form von Auszügen, ist ohne vorheriges schriftliches Einverständnis der Dürkopp Adler AG verboten.

All rights reserved.

Property of Dürkopp Adler AG and protected by copyright. Any reuse of these contents, including extracts, is prohibited without the prior written approval of Dürkopp Adler AG.

Copyright © Dürkopp Adler AG 2018

867 - M Standard

Inhaltsverzeichnis	Tafel / Table	Contents
Armwelle,	1	Upper shaft,
Armwelle-Sensitiv		Upper shaft-Sensitiv
Antrieb Arm- und Unterwelle,	2	Upper and bottom shaft drive,
Rastkupplung		Safety clutch
Fadenhebel	3	Thread lever
Fadenhebel-Sensitiv	4	Thread lever-Sensitiv
Antrieb Nadeltransport	5	Needle feed drive
Alternierender Obertransport,	6	Alternating foot top feed,
Alternierender Obertransport-Sensitiv,		Alternating foot top feed-Sensitiv,
Fussfuehrung		Foot guide
Antrieb Untertransport	7	Bottom feed drive
Transporteurhub	8	Bottom feed
Fusslueftung	9	Presser foot lift hand lever
Fusslueftung mech.	10	Presser foot lift knee lever
Fusslueftung pneu.	11	Presser foot lift pneumatic
Hubverstellung	12	Skipping foot lift pneumatic
Grosser Greifer mit Spule-Sensitiv	13	Large hook with bobbin-Sensitiv
Grosser Greifer mit Spule	14	Large hook with bobbin
Grosser Greifer	15	Large hook
Uebergrosser Greifer mit Spule	16	Oversized hook with bobbin
Uebergrosser Greifer	17	Oversized hook
Uebergrosser Greifer mit Spule KFA	18	Oversized hook with bobbin short thread trimmer
Grosser Greifer mit Spule KFA	19	Large hook with bobbin short thread trimmer
Greiferlager rechts	20	Hook case right
Greiferlager links	21	Hook case left
Fadenabschneider	22	Thread trimmer
Kurz-Fadenabschneider	23	Short thread trimmer
Spuler	24	Winder
Spannungsplatte Einnadel mech.	25	Tension plate 1 needle mech.
Spannungsplatte Einnadel pneu.	26	Tension plate 1 needle pneu.
Spannungsplatte Einnadel pneu.,	27	Tension plate 1 needle, pneu.,
Spannungsplatte Einnadel pneu.		Tension plate 1 needle, pneu.
-Sensitiv		-Sensitiv
Spannungsplatte Zweinadel mech.	28	Tension plate 2 needles mech.
Spannungsplatte Zweinadel pneu.	29	Tension plate 2 needles pneu.
Spannungsplatte Zweinadel pneu.	30	Tension plate 2 needles pneu.
Spannungsplatte Zweinadel pneu.		Tension plate 2 needles pneu.
-Sensitiv		-Sensitiv
Stichverstellung 1 Stichlaenge,	31	Stitch adjustment 1 stitch length,
Stichverkuerzung, Drehzahlregler		Stitch reduction, Speed regulator
Stichverstellung 2 Stichlaengen,	32	Stitch adjustment 2 stitch lengths,
Stichverkuerzung		Stitch reduction

867 - M Standard

Inhaltsverzeichnis	Tafel / Table	Contents
Verriegelung mech., pneu., Stichverkuerzung	33	Backtacking mech., pneu., Stitch reduction
Teilesatz-Blockierung		Parts set blocking
Magnetventileinheit, Taster	34 - 37	Solenoid valve unit, Push-buttons
Zentralschmierung	38	Central lubrication
Arm, Fadenuerung,	39	Arm, Thread guide,
Integr. Diodennaehleuchte		Sewing light LEDs
Armdeckel ECO	40	Arm cover ECO
Armdeckel CLASSIC	41	Arm cover CLASSIC
Armdeckel CLASSIC mit Blockierung	42	Arm cover CLASSIC with blocking
Grundplatte, Abdeckung	43	Bed plate, Cover
Diodennaehleuchte	44	Sewing light LED
Antriebspaket fuer Direktantrieb	45 - 47	Motor kit for direct drive
Gestell	48	Stand
Wartungseinheit	49	Maintenance unit
Beipack	50, 51	Accessories
Restfadenwaechter	52	Thread monitor
Elektropneum. Nadelkuehlung von oben, unten	53	Electropneum. needle cooling upper, lower
Integr. Diodennaehleuchte	54	Sewing light LEDs
Netzteil		Power supply
Kantenanschlag		Edge guide
Lineal auf Schieber		Edge guide
Rollenanschlag		Roller stop
Nahtmittenfuehrung schwenkbar		Swivelling seam centre guide
Nahtmittenfuehrung		Seam centre guide
Nahtmittenfuehrung von vorne pneum. schaltbar	55	Electropneum. seam centre guide
Kantenanschlag		Edge guide
Eindiodennaehleuchte	56	Sewing lamp LED
Fuesschenlueftung pneu.	57	Sewing foot lift pneu.
Fuesschenlueftung mech.		Manual foot lift pedal
Visuelle Spuleneberwachung	58	Visual monitoring of bobbin
Reflexlichtschränke	59	Light barrier
Werkzeug M-Type		Tool kits M-Type
Elektronisches Handrad		Electronic hand wheel
Stichlaengeblockierung	60	Stitch length blocking
Teilesatz FK		Parts set FK
USB Memory Stick		USB memory key
Greifer		Hook
Fussfuehrung		Foot guide
2-Fach Steckdose		Socket double
Tischplatte	61	Table top
Elektrisch hoeohenverstellbares Gestell		Stand el. adjustable
Pedal K20		Pedal K20
Pedal Ergobody		Pedal Ergobody
Teilesatz		Parts set

867 - M Standard

Inhaltsverzeichnis	Tafel / Table	Contents
Tischplatte	62	Table top
Puller	63 - 66	Puller
Sicherheits-Features	67	Safety features
Diodennaehleuchte	68	Sewing light LED
Lockout Luft und Strom		Lockout air and power
Betaetigung Efka		Efka control
Hauptschalter		Main switch
Bausatz NSB	69, 70	NSB kit
Index		Index
Stichplattenschieber		Slide
Befestigungsteile fuer Naeheinrichtung		Fastening parts for sewing equip.
Naeheinrichtungen		Sewing equipment
Bauschaltplan		Wiring diagram
Pneu. Geraeteplan		Pneumatic circuit plan

867 - M Standard

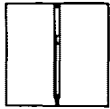

Einnadel-Maschine
single needle machine

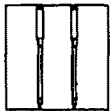

Zweinadel-Maschine
two needle machine

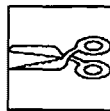

mit Fadenabschneider
with thread trimmer

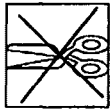

ohne Fadenabschneider
without thread trimmer

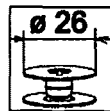

ø 26
grosser Greifer
large hook

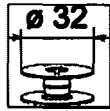

ø 32
uebergrosser Greifer (XXL)
oversized hook (XXL)



Kurz-Fadenabschneider
short thread trimmer



ohne Kurz-Fadenabschneider
without short thread trimmer



kleben/stick

N nicht einzeln lieferbar/not available as separate part

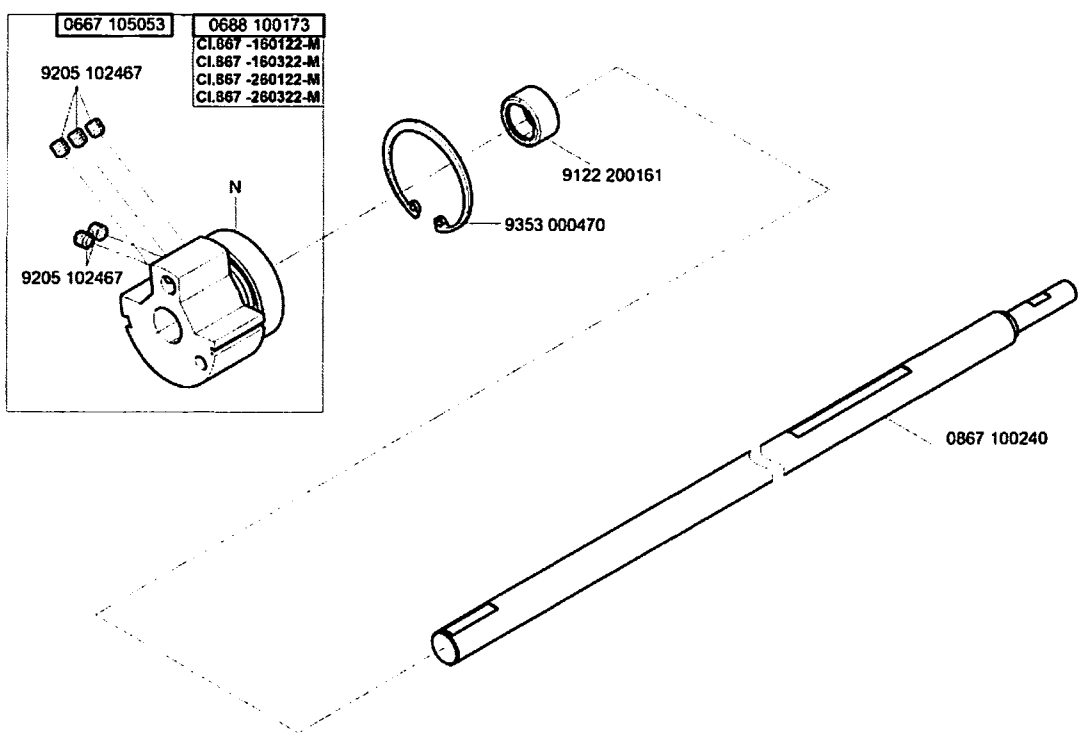

N - nicht als Einzelteil lieferbar
not available as separate part

CI. 867 - M Standard

Ausgabe/Edition 10.2017

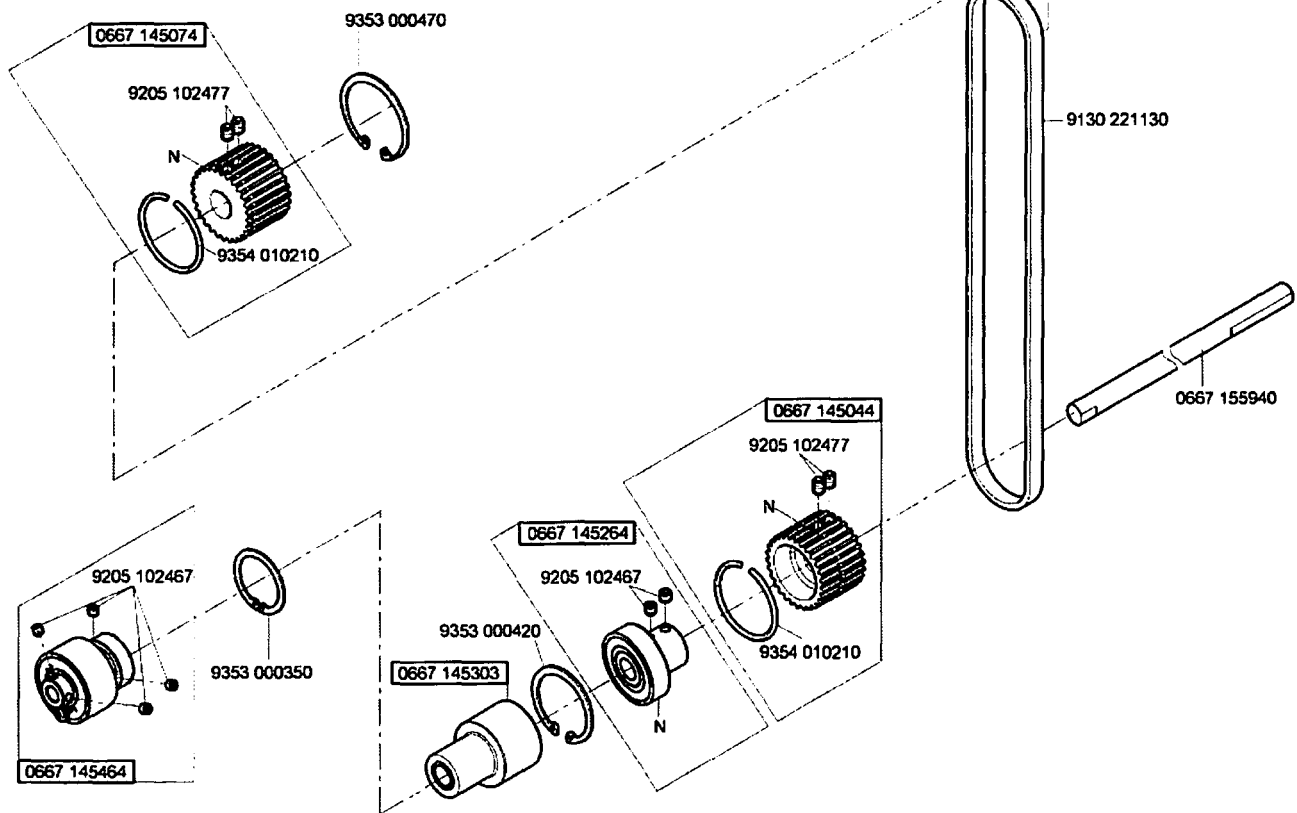

N - nicht als Einzelteil lieferbar
not available as separate part

Cl. 867 - M Standard

Ausgabe/Edition 6.2012

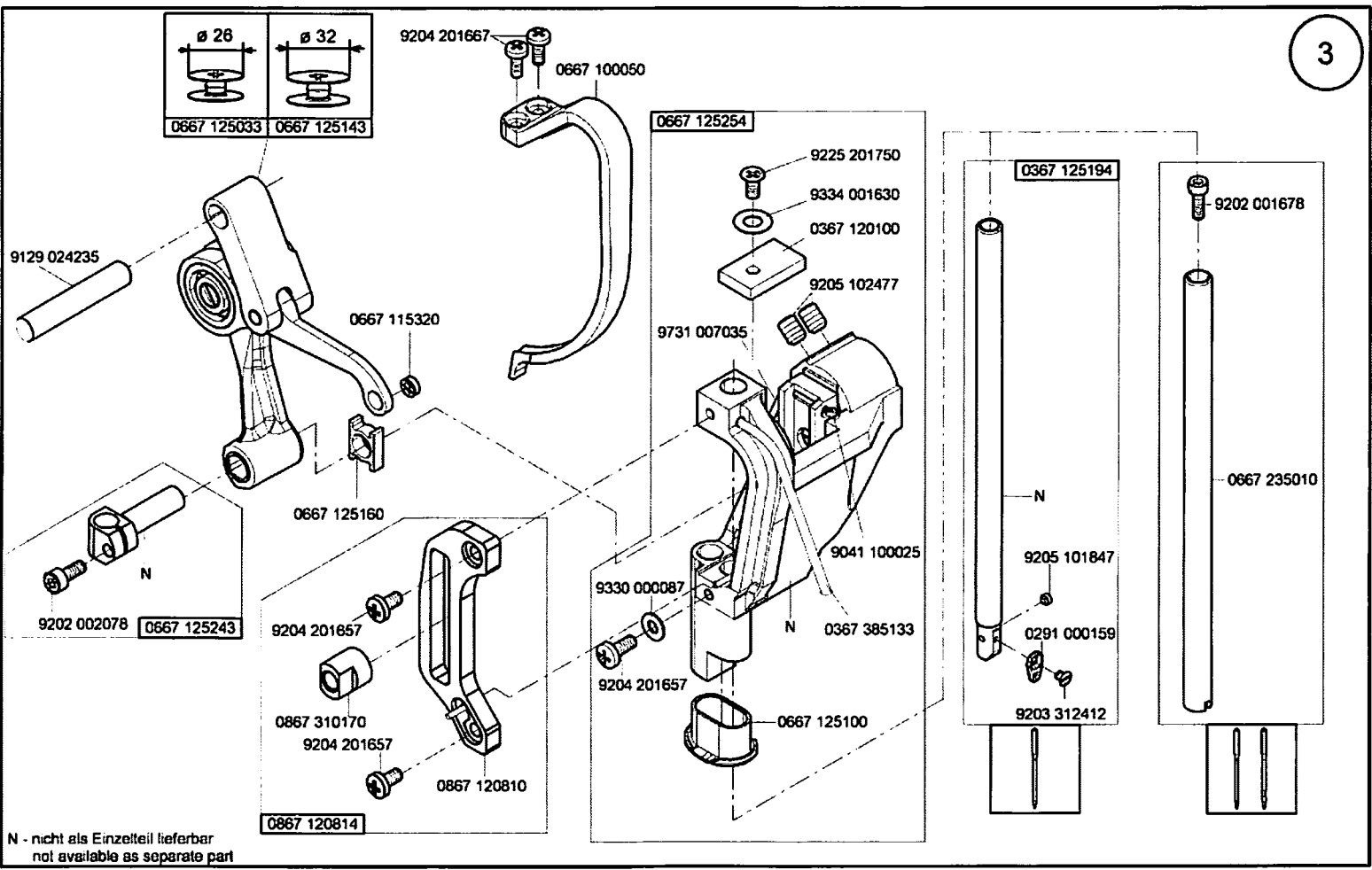

Cl. 867 - M Standard

CI.867 -160122-M
CI.867 -160322-M
CI.867 -260122-M
CI.867 -260322-M

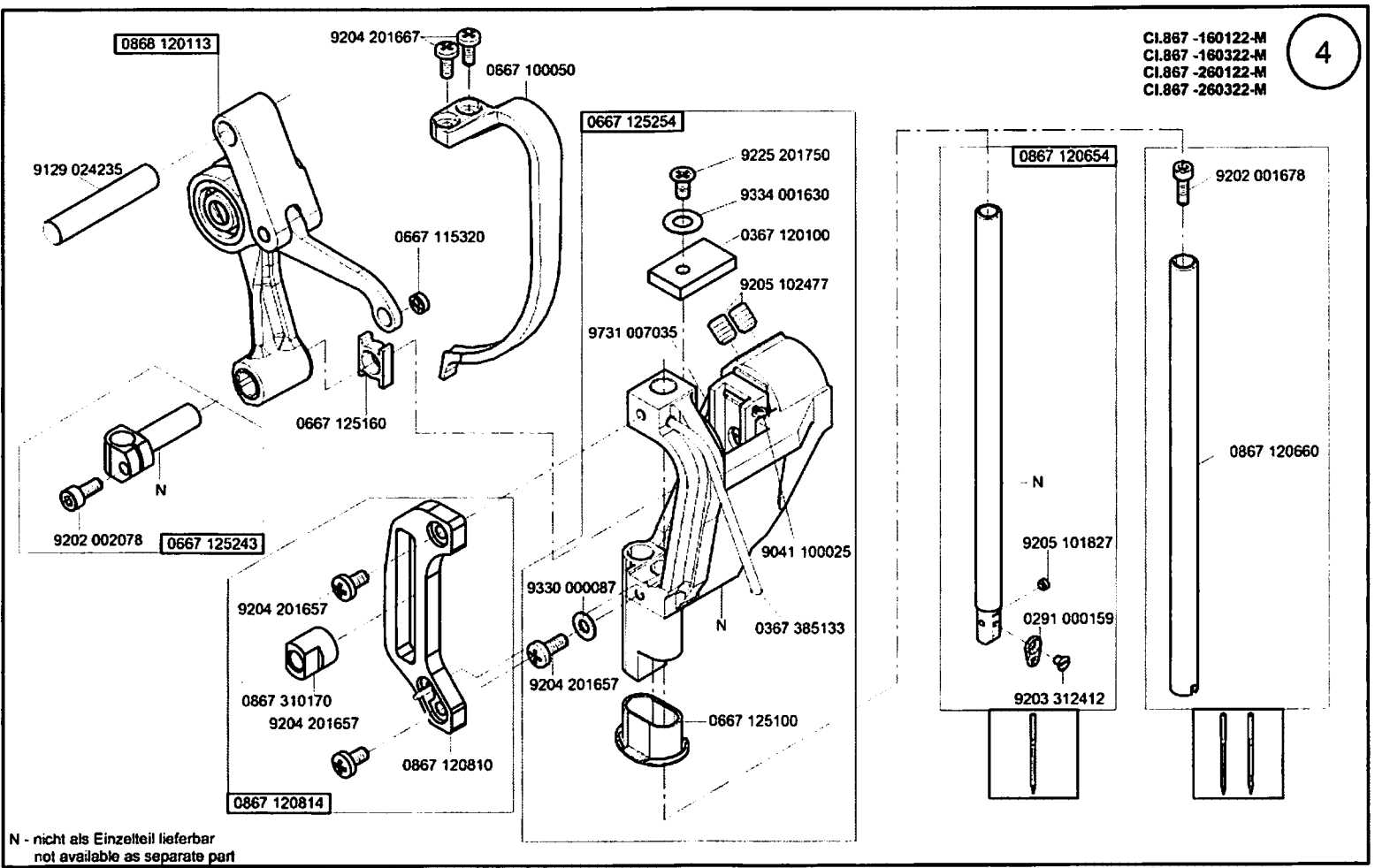

N - nicht als Einzelteil lieferbar
not available as separate part

CI. 867 - M Standard

Ausgabe/Edition 10.2017

5

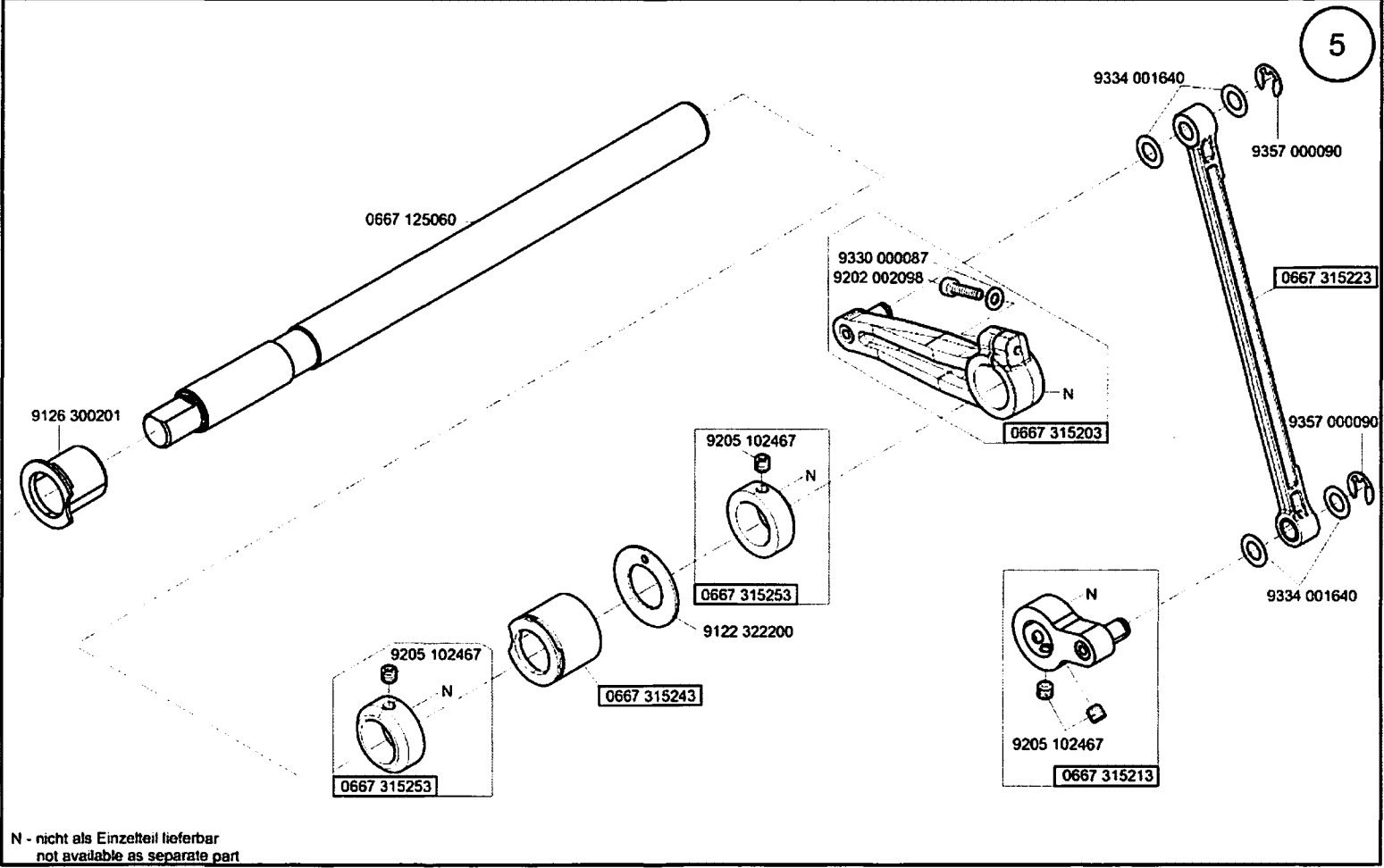

Cl. 867 - M Standard

Ausgabe/Edition 10.2018

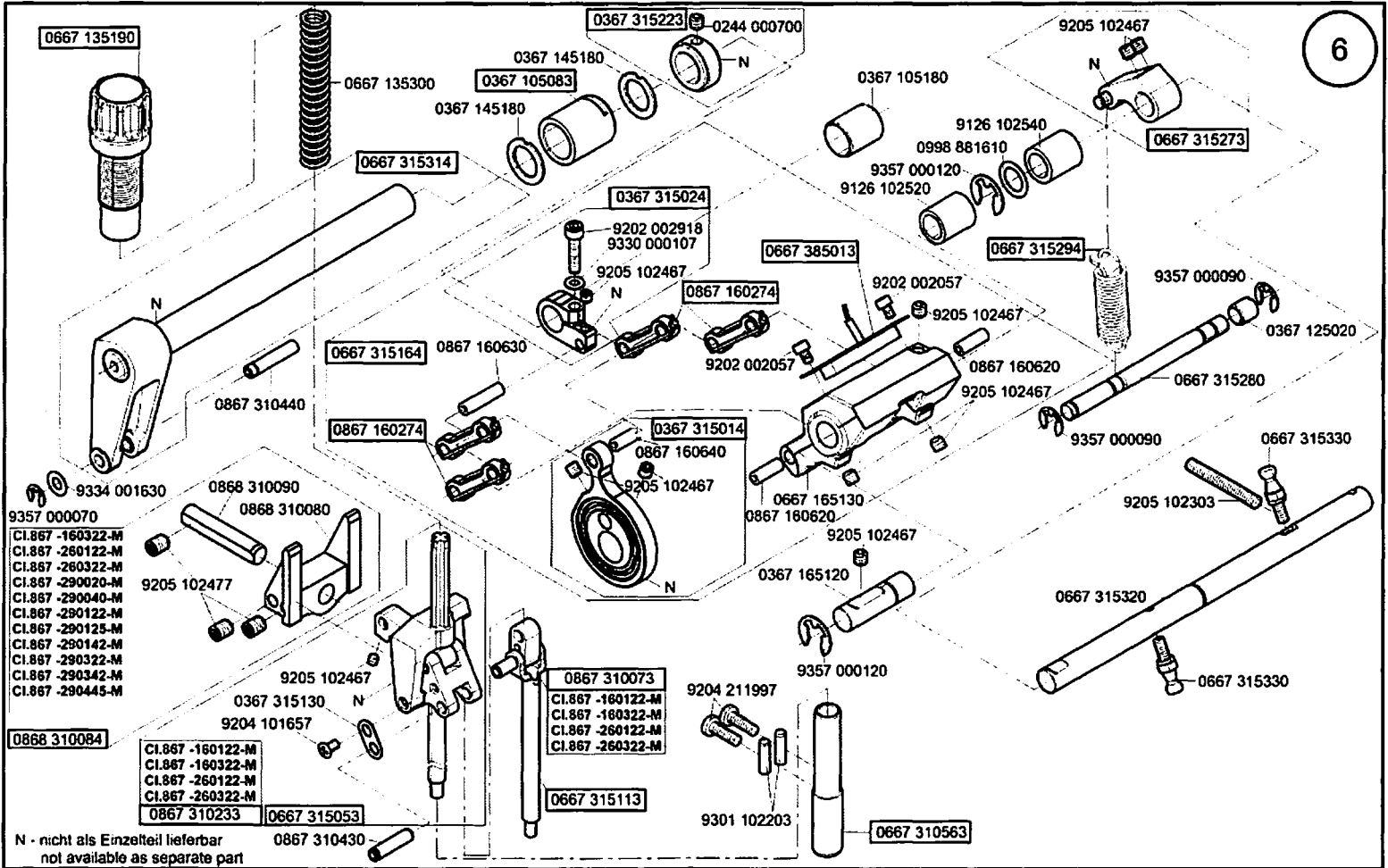

Cl. 867 - M Standard

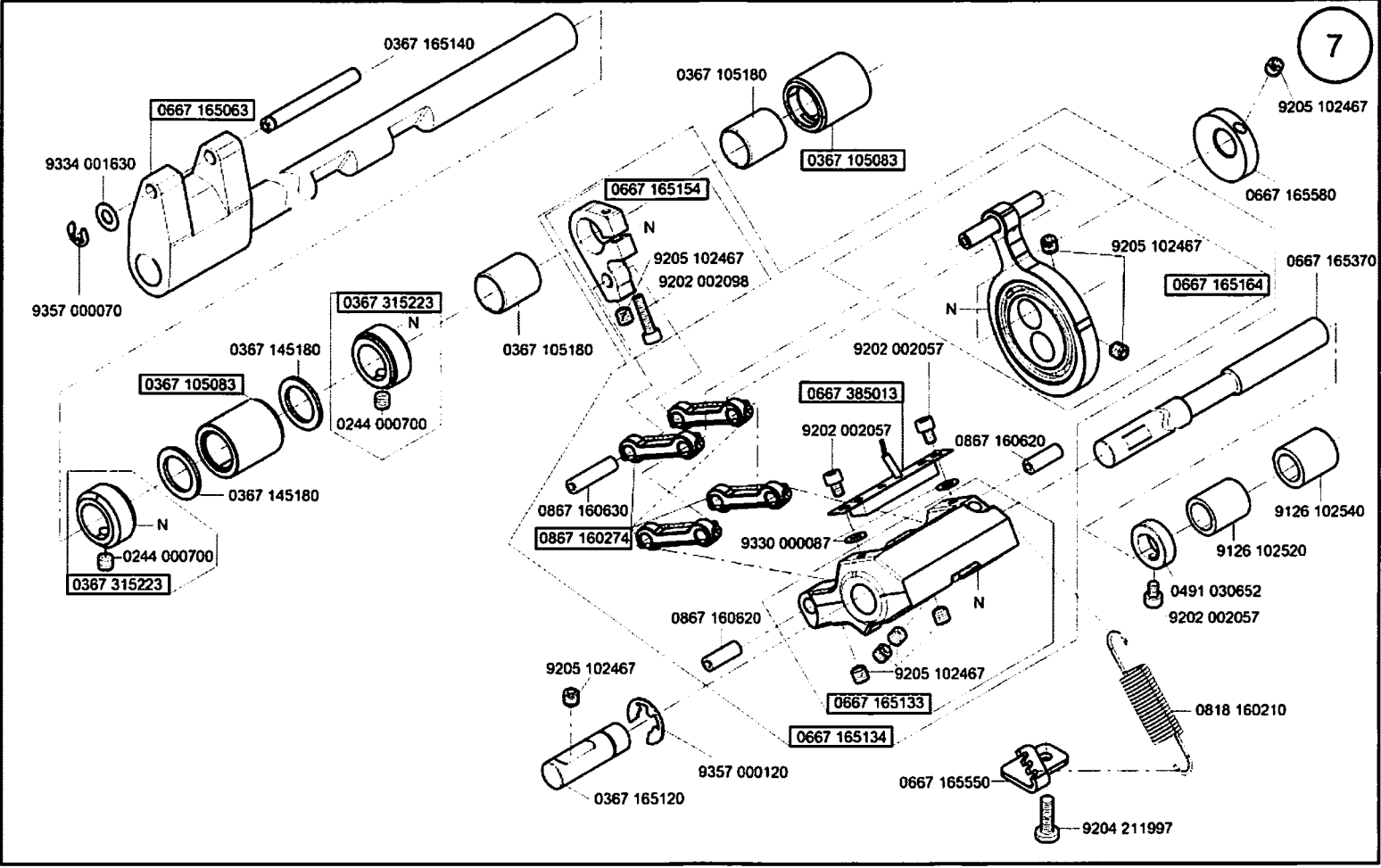

Cl. 867 - M Standard

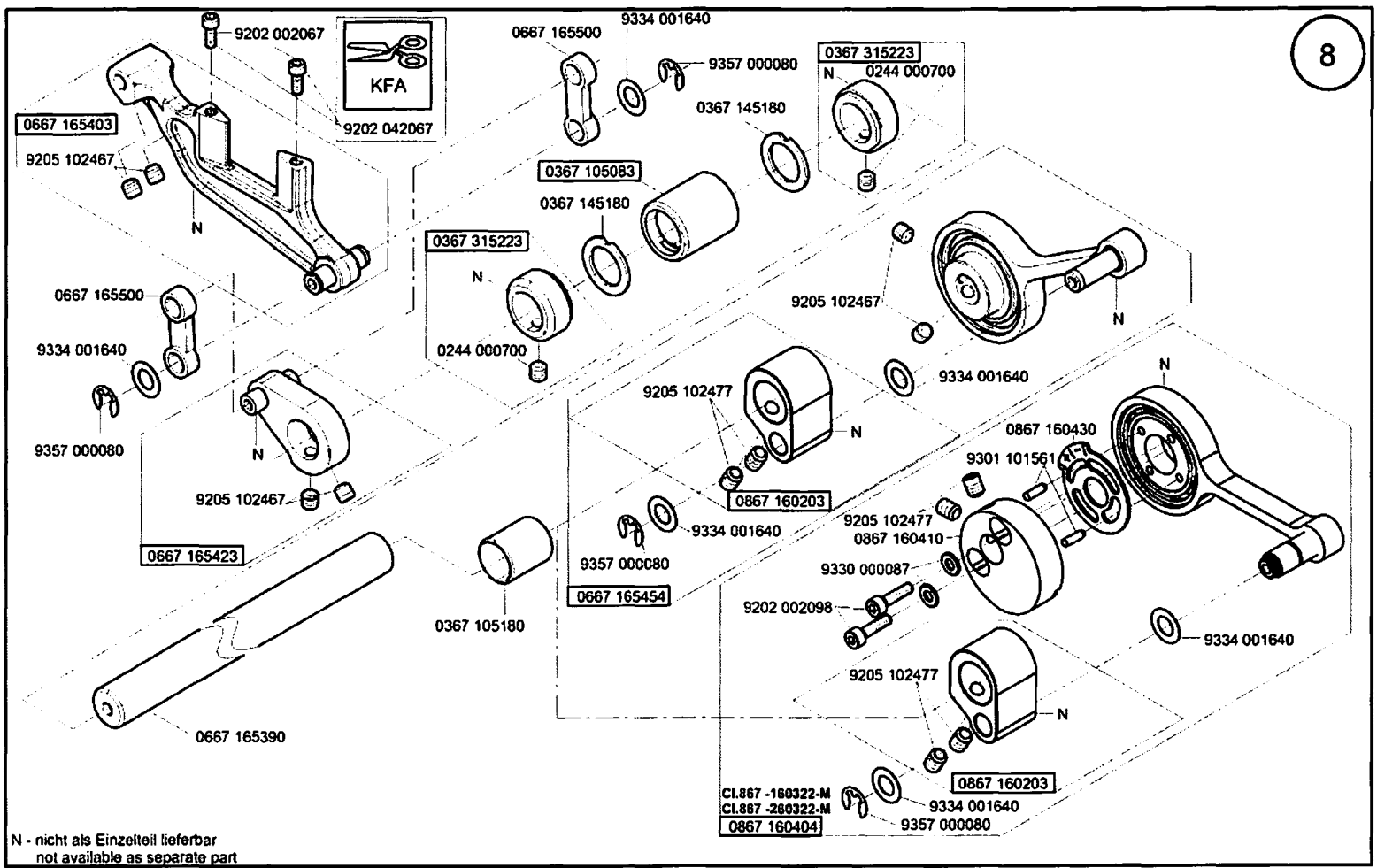

CI. 867 - M Standard

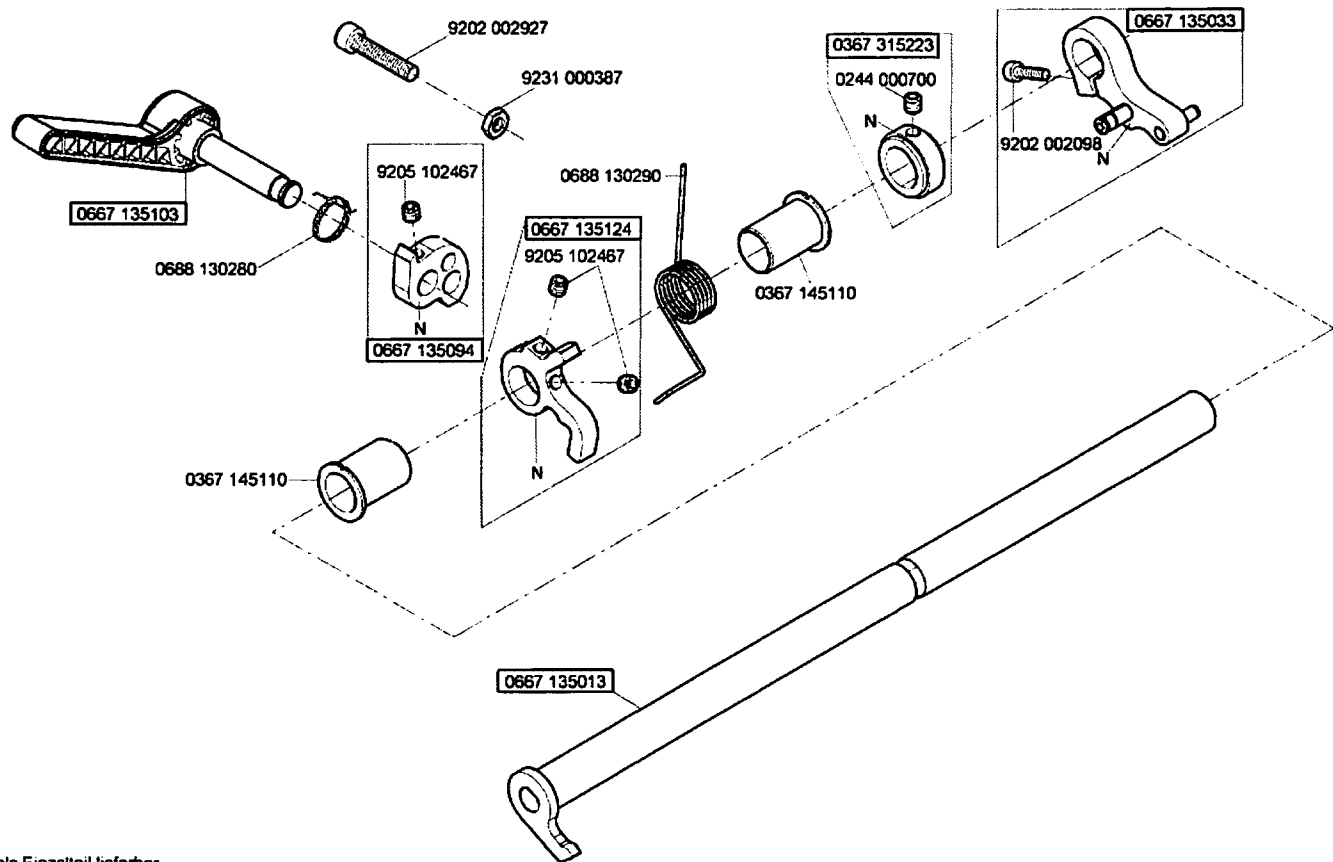

N - nicht als Einzelteil lieferbar
not available as separate part

Cl. 867 - M Standard

Ausgabe/Edition 2.2013



CI.867 -180020-M
 CI.867 -180040-M
 CI.867 -280020-M
 CI.867 -280040-M

10

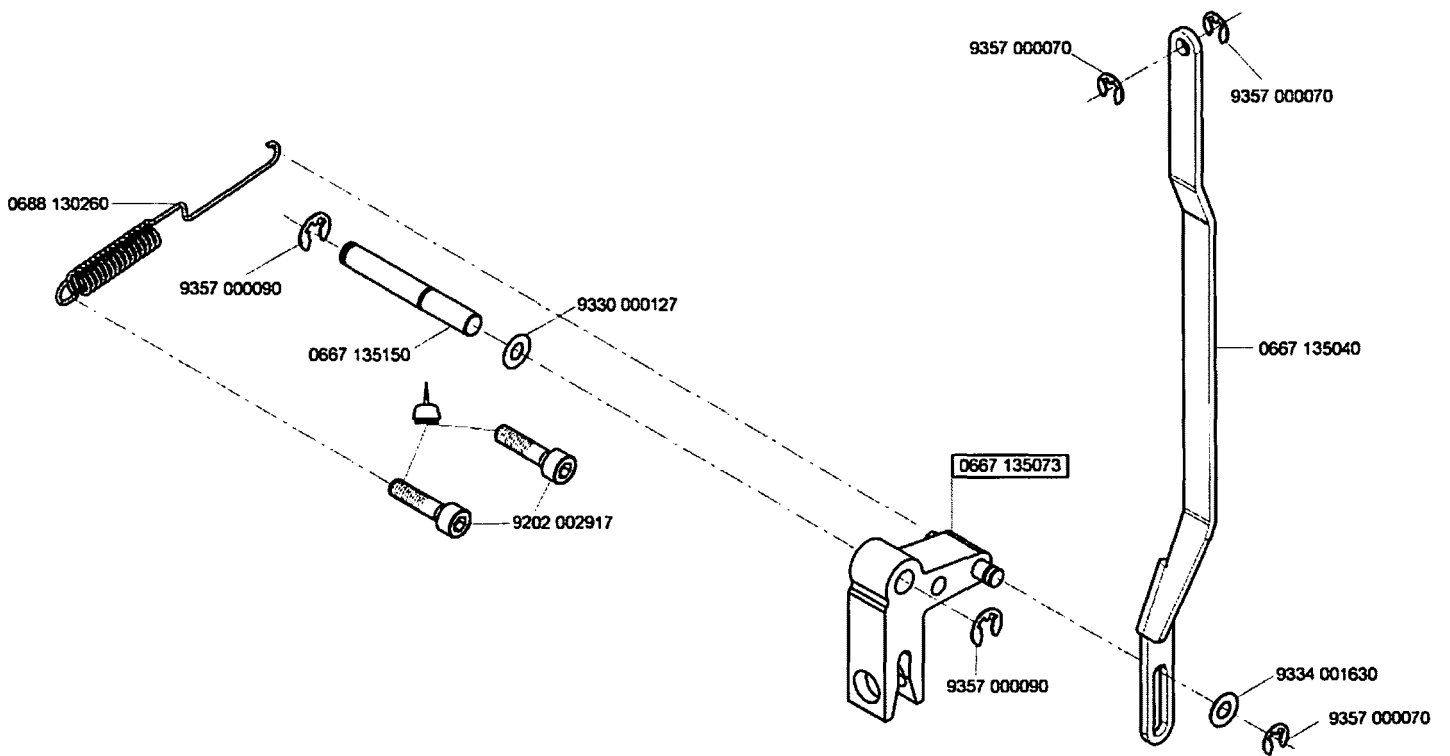

N - nicht als Einzelteil lieferbar
 not available as separate part  -kleben -stick

CI. 867 - M Standard

Ausgabe/Edition 6 2012

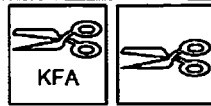

- CI.867 -160122-M
- CI.867 -160322-M
- CI.867 -190122-M
- CI.867 -190125-M
- CI.867 -190142-M
- CI.867 -190145-M
- CI.867 -190322-M
- CI.867 -190342-M
- CI.867 -190425-M
- CI.867 -190445-M
- CI.867 -260122-M
- CI.867 -260322-M
- CI.867 -290122-M
- CI.867 -290125-M
- CI.867 -290142-M
- CI.867 -290322-M
- CI.867 -290342-M
- CI.867 -290445-M

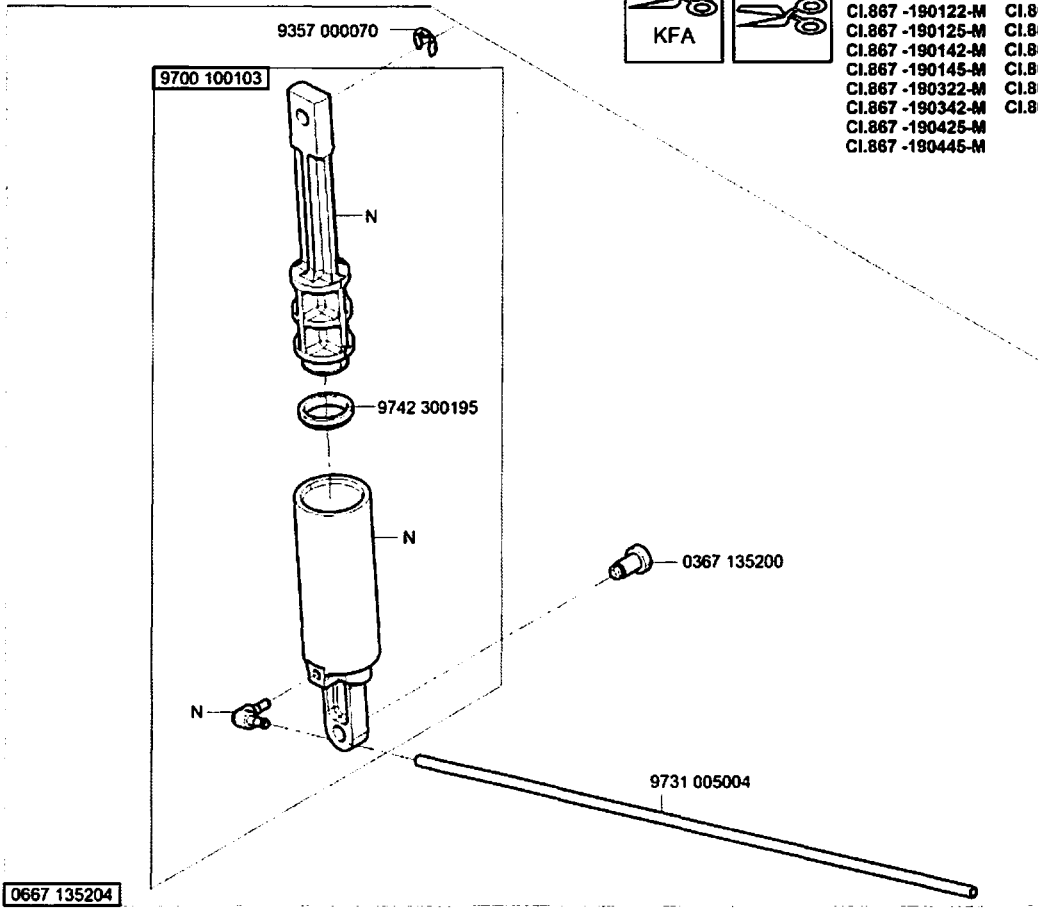

N - nicht als Einzelteil lieferbar
not available as separate part

0667 135204

CI. 867 - M Standard

Ausgabe/Edition 11.2018

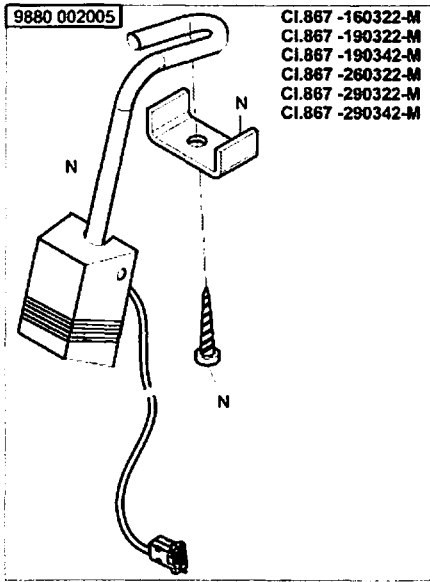

9880 002005

- CI.867 -160322-M
- CI.867 -190322-M
- CI.867 -190342-M
- CI.867 -260322-M
- CI.867 -290322-M
- CI.867 -290342-M

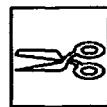
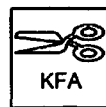
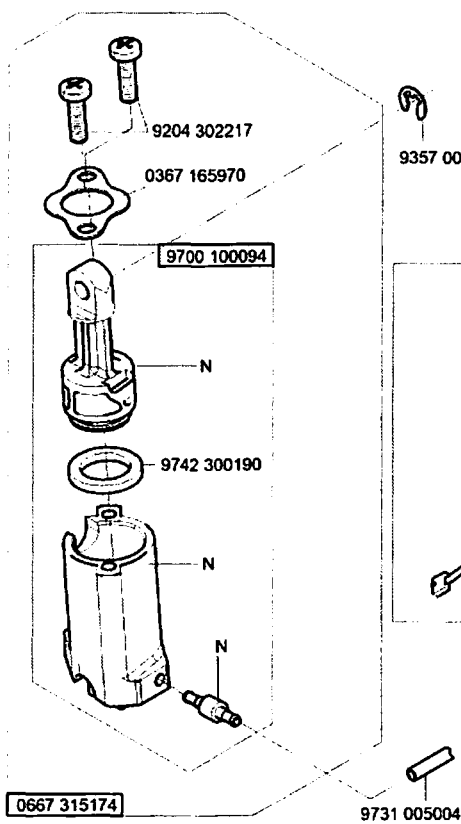

- CI.867 -160322-M
- CI.867 -190322-M
- CI.867 -190342-M
- CI.867 -260322-M
- CI.867 -290322-M
- CI.867 -290342-M

9357 000070

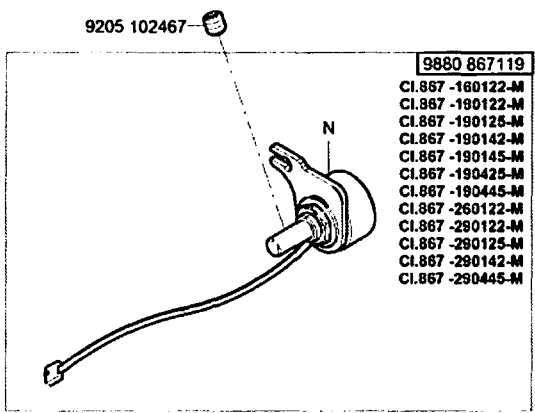

9205 102467

9880 867119

- CI.867 -160122-M
- CI.867 -190122-M
- CI.867 -190125-M
- CI.867 -190142-M
- CI.867 -190145-M
- CI.867 -190425-M
- CI.867 -190445-M
- CI.867 -260122-M
- CI.867 -290122-M
- CI.867 -290125-M
- CI.867 -290142-M
- CI.867 -290445-M

N - nicht als Einzelteil lieferbar
not available as separate part

CI. 867 - M Standard

Ausgabe/Edition 11.2018

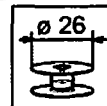

CI.867 -160122-M
CI.867 -160322-M
CI.867 -260122-M
CI.867 -260322-M

13

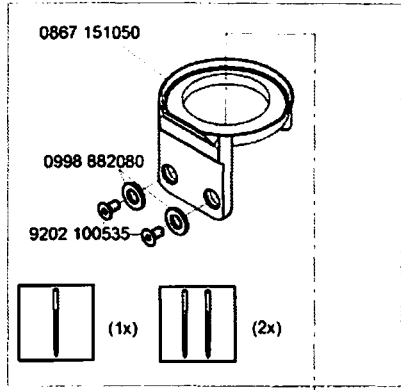
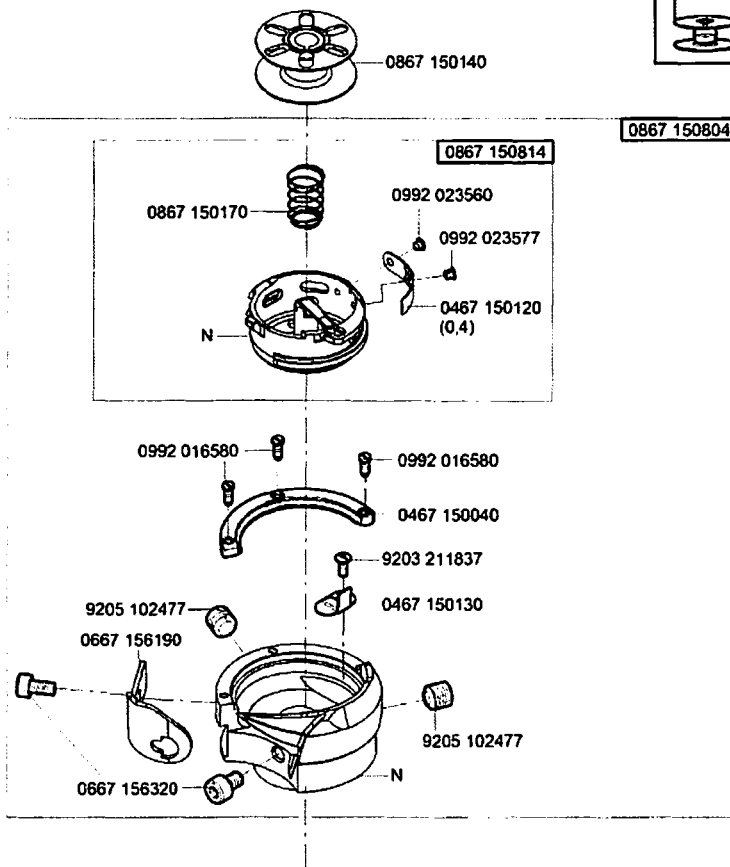

N - nicht als Einzelteil lieferbar
not available as separate part

CI. 867 - M Standard

Ausgabe/Edition 10.2017

CI.867 -190020-M
CI.867 -190122-M
CI.867 -190322-M
CI.867 -290020-M
CI.867 -290122-M
CI.867 -290322-M

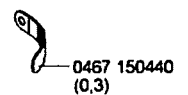
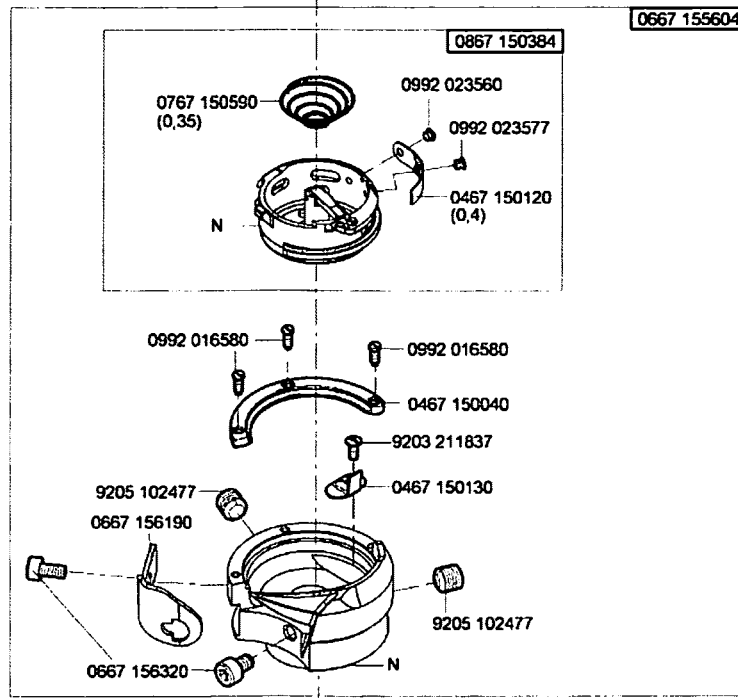
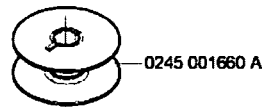
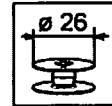

auf Wunsch
on request

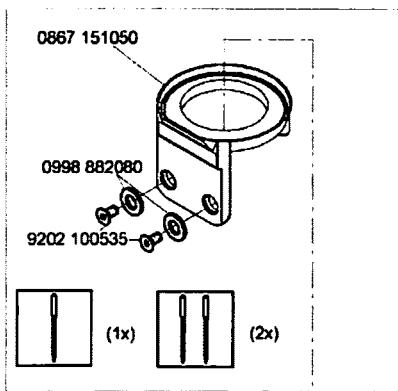

N - nicht als Einzelteil lieferbar
not available as separate part

CI. 867 - M Standard

Ausgabe/Edition 1 2017

auf Wunsch
on request

DLC - beschichtet für minimale Dischmierung
DLC - coated for minimal lubrication

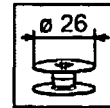

CI.867 -160122-M
CI.867 -160322-M
CI.867 -190020-M
CI.867 -190122-M
CI.867 -190322-M
CI.867 -260122-M
CI.867 -260322-M
CI.867 -290020-M
CI.867 -290122-M
CI.867 -290322-M

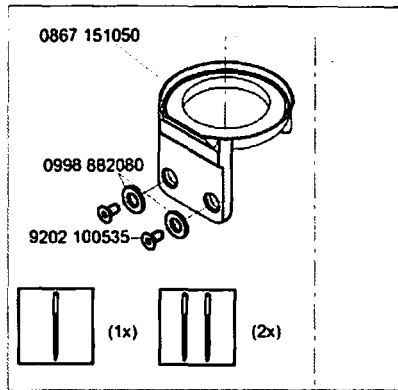
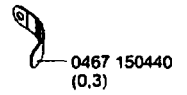
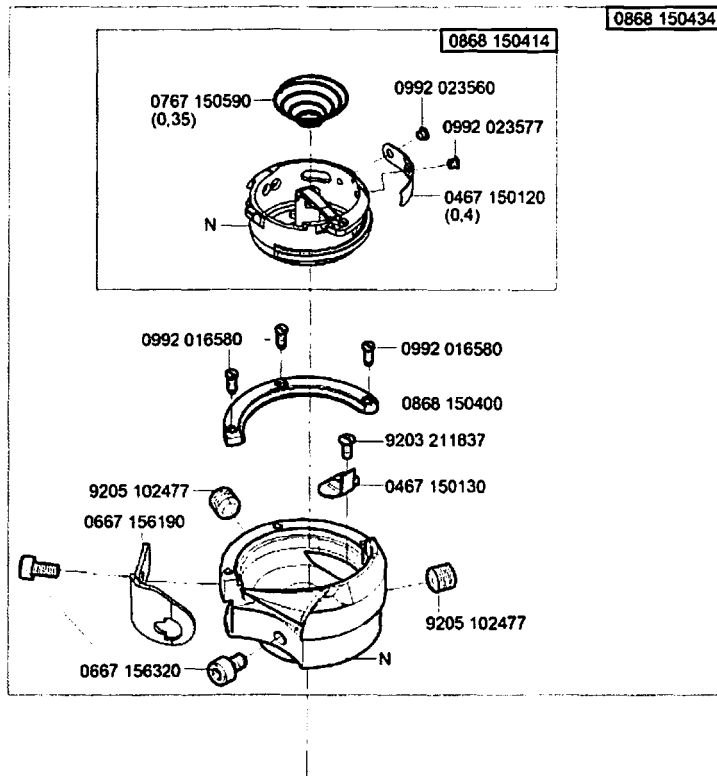

N - nicht als Einzelteil lieferbar
not available as separate part

CI. 867 - M Standard

Ausgabe/Edition 10.2017

auf Wunsch
on request

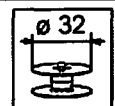
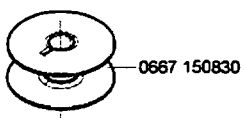
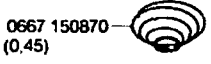

Cl.867 -190040-M
Cl.867 -190142-M
Cl.867 -190342-M
Cl.867 -290040-M
Cl.867 -290142-M
Cl.867 -290342-M

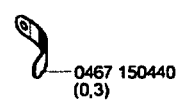
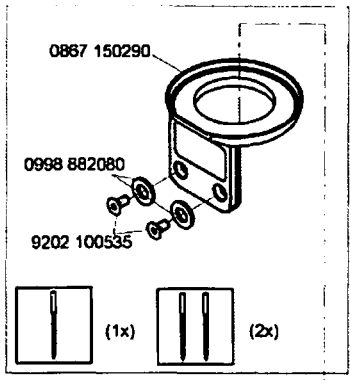
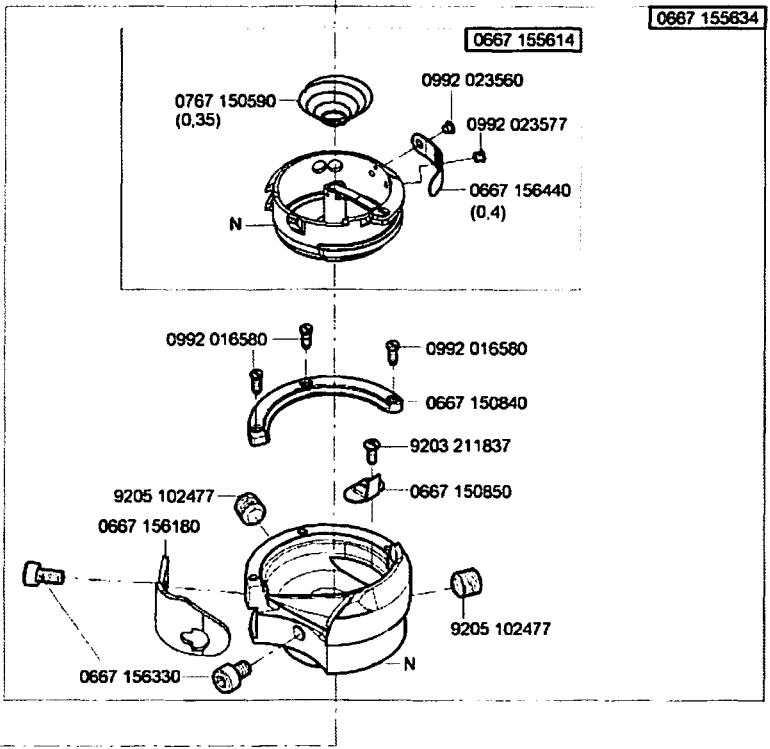

auf Wunsch
on request



auf Wunsch
on request

N - nicht als Einzelteil lieferbar
not available as separate part

Cl. 867 - M Standard

Ausgabe/Edition 6.2016

auf Wunsch
on request

DLC - beschichtet für minimale Ölschmierung
DLC - coated for minimal lubrication

auf Wunsch
on request

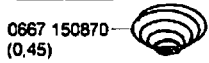

0667 150870
(0,45)

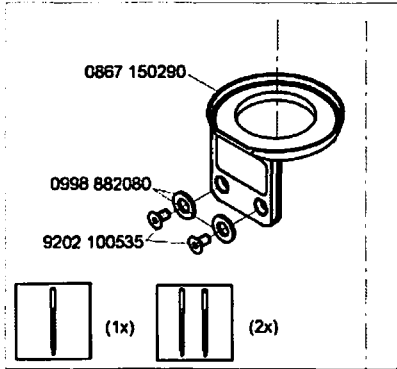

0867 150290

0998 882080

9202 100535

(1x)

(2x)

N - nicht als Einzelteil lieferbar
not available as separate part

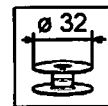

CI.867 -190040-M
CI.867 -190142-M
CI.867 -190342-M
CI.867 -290040-M
CI.867 -290142-M
CI.867 -290342-M

17

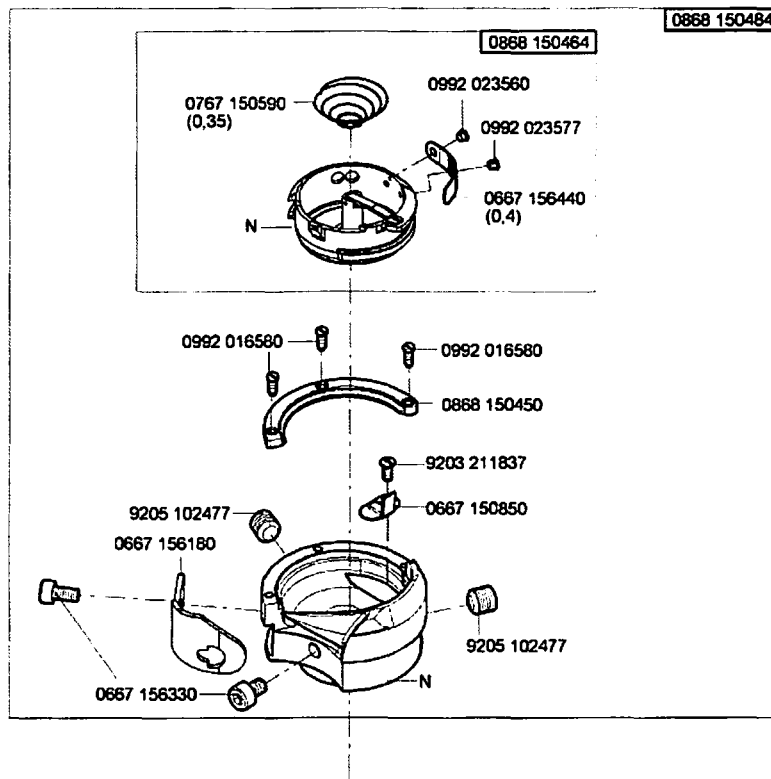

0868 150464

0767 150590
(0,35)

0992 023560

0992 023577

0667 156440
(0,4)

0992 016580

0992 016580

0868 150450

9203 211837

0667 150850

9205 102477

0667 156180

9205 102477

0667 156330

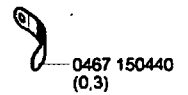

0467 150440
(0,3)

0868 150520



CI. 867 - M Standard

Ausgabe/Edition 6.2016

Cl.867 -190145-M
Cl.867 -190445-M
Cl.867 -290445-M

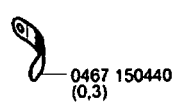
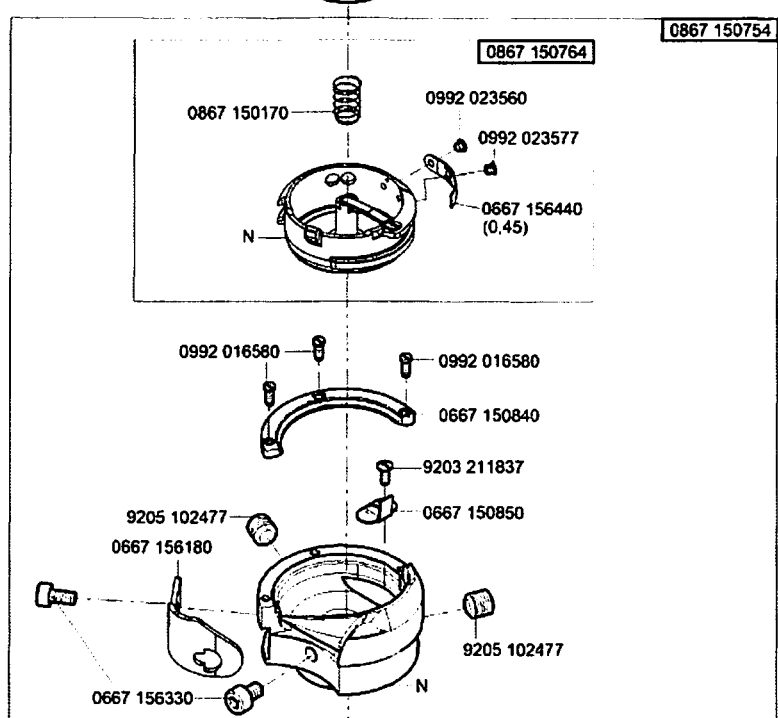
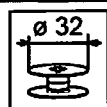

auf Wunsch
on request



auf Wunsch
on request

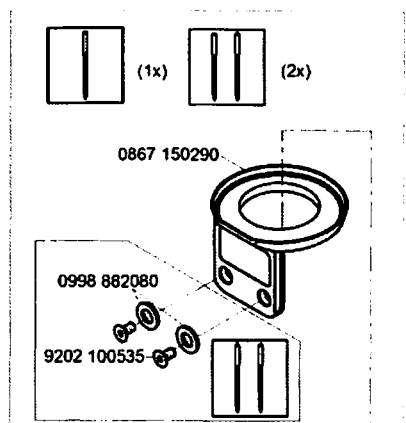

N - nicht als Einzelteil lieferbar
not available as separate part

Cl. 867 - M Standard

Ausgabe/Edition 11.2018

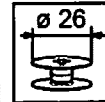

CI.867 -190125-M
CI.867 -190425-M
CI.867 -290125-M



0867 150140

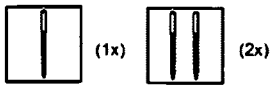
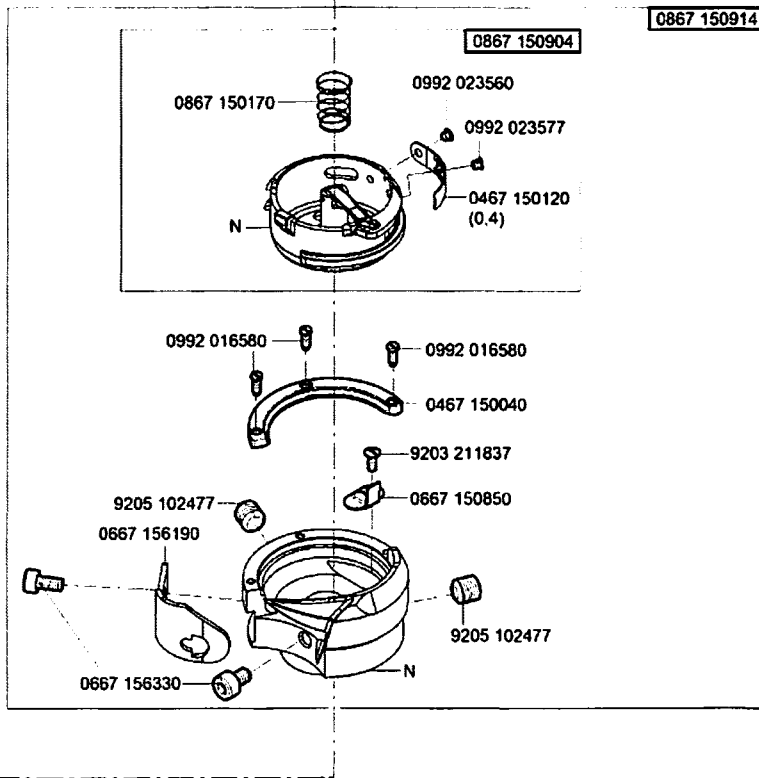

(1x)

(2x)

0867 151050

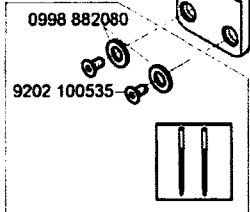

0998 882080

9202 100535

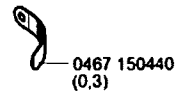

0467 150440 (0,3)

auf Wunsch
on request

0667 156130



auf Wunsch
on request

N - nicht als Einzelteil lieferbar
not available as separate part

CI. 867 - M Standard

Ausgabe/Edition 11.2018

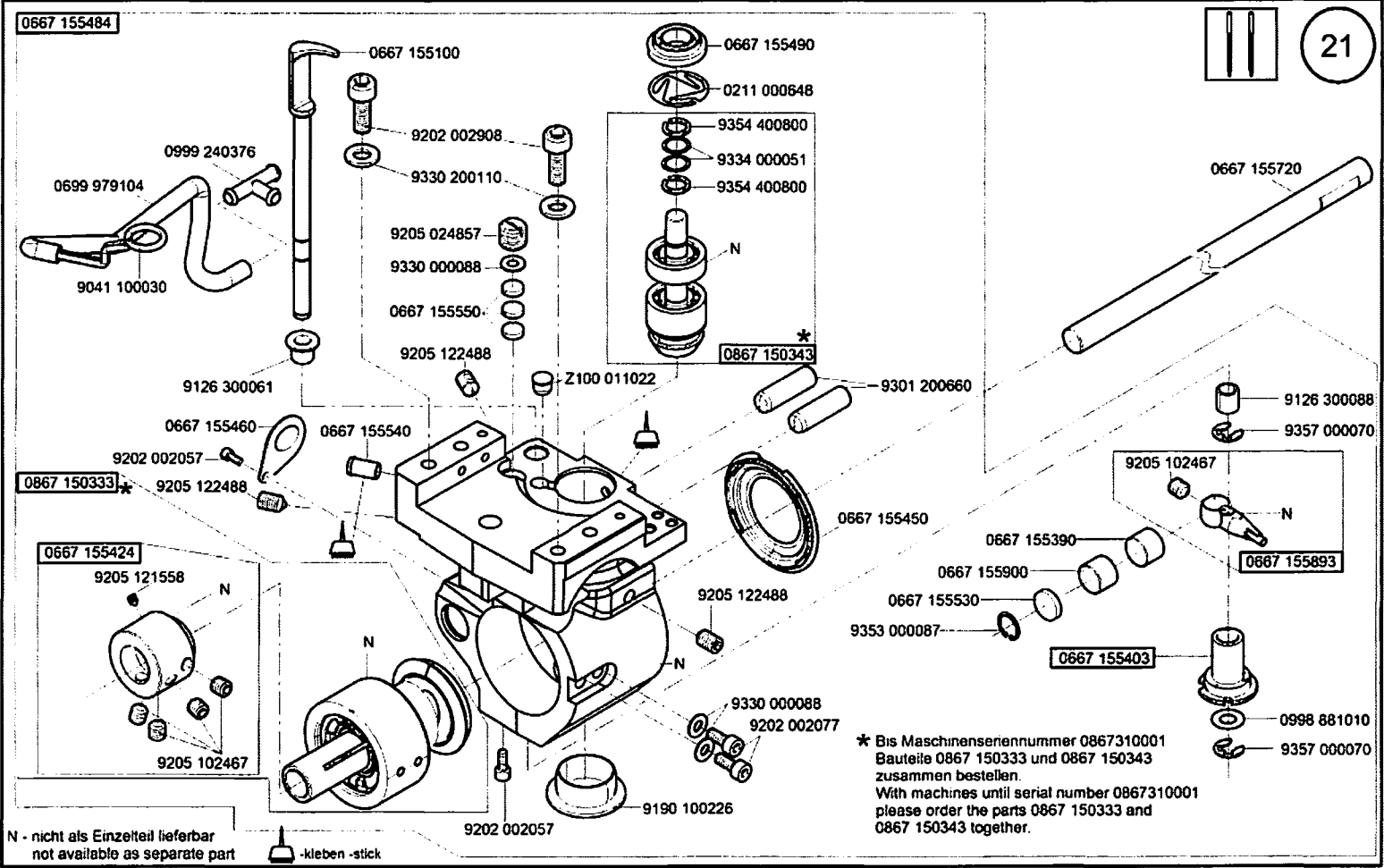

Cl. 867 - M Standard

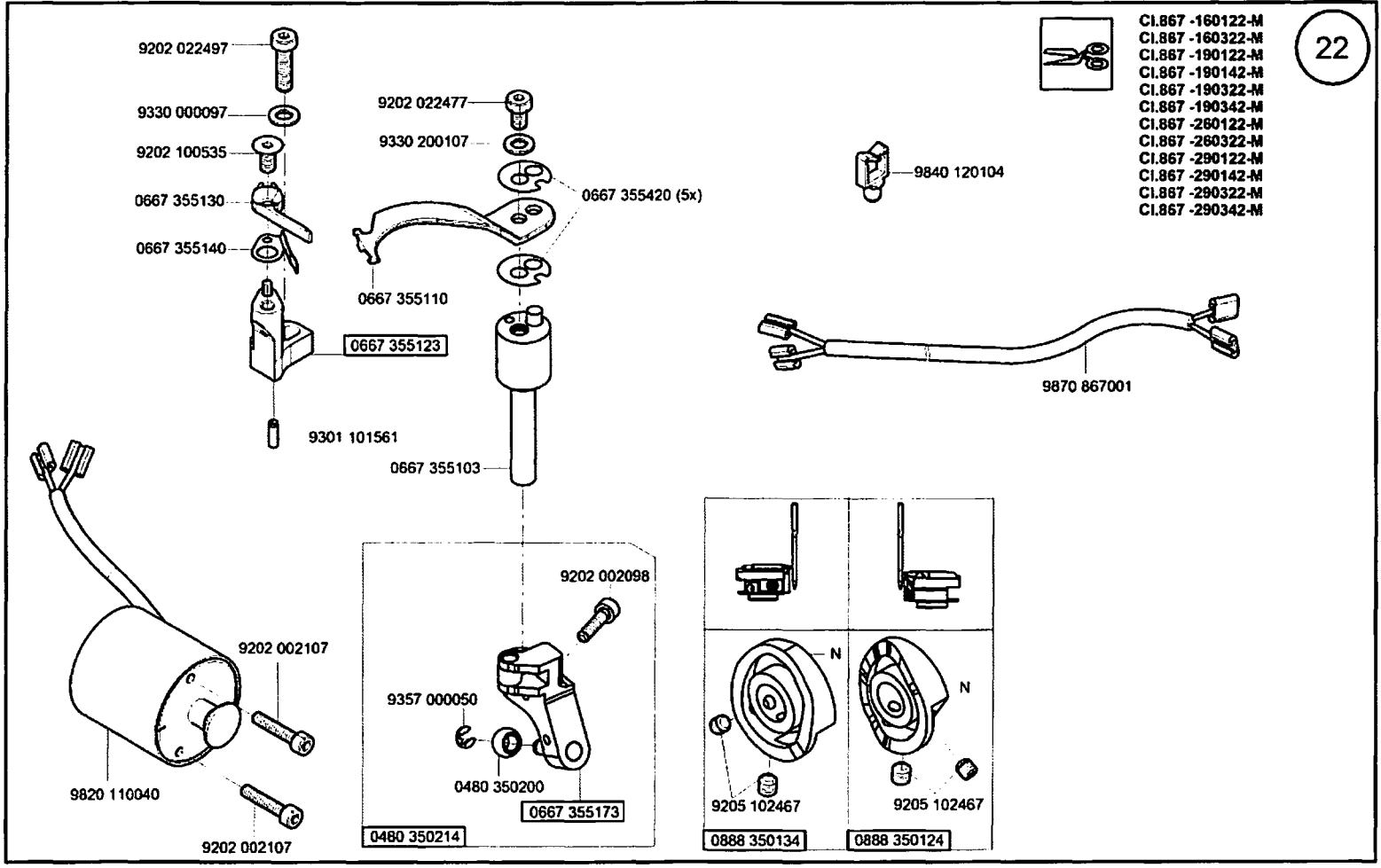

CI. 867 - M Standard

Ausgabe/Edition 10.2017

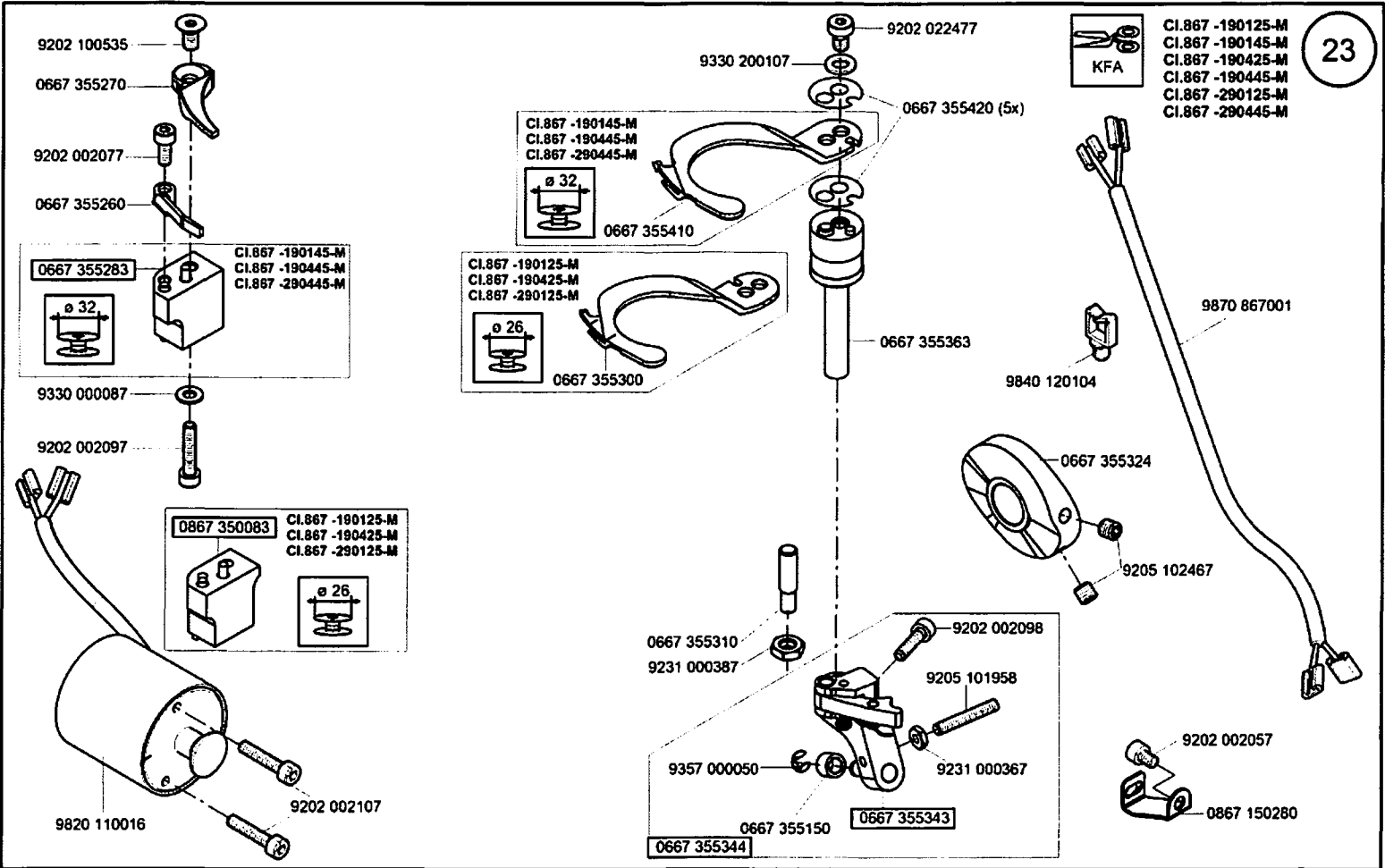

Cl. 867 - M Standard

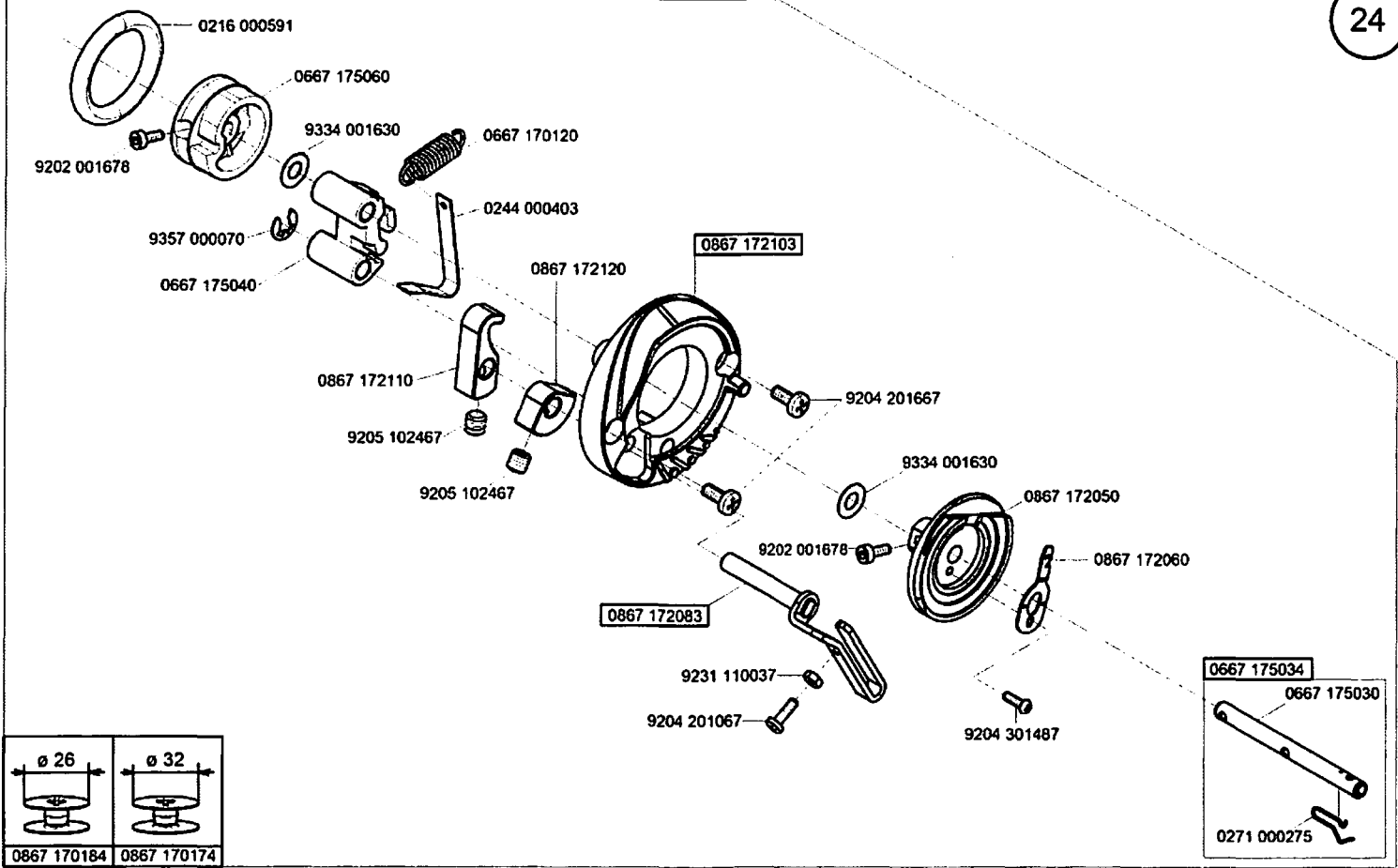

Cl. 867 - M Standard

Ausgabe/Edition 1.2015

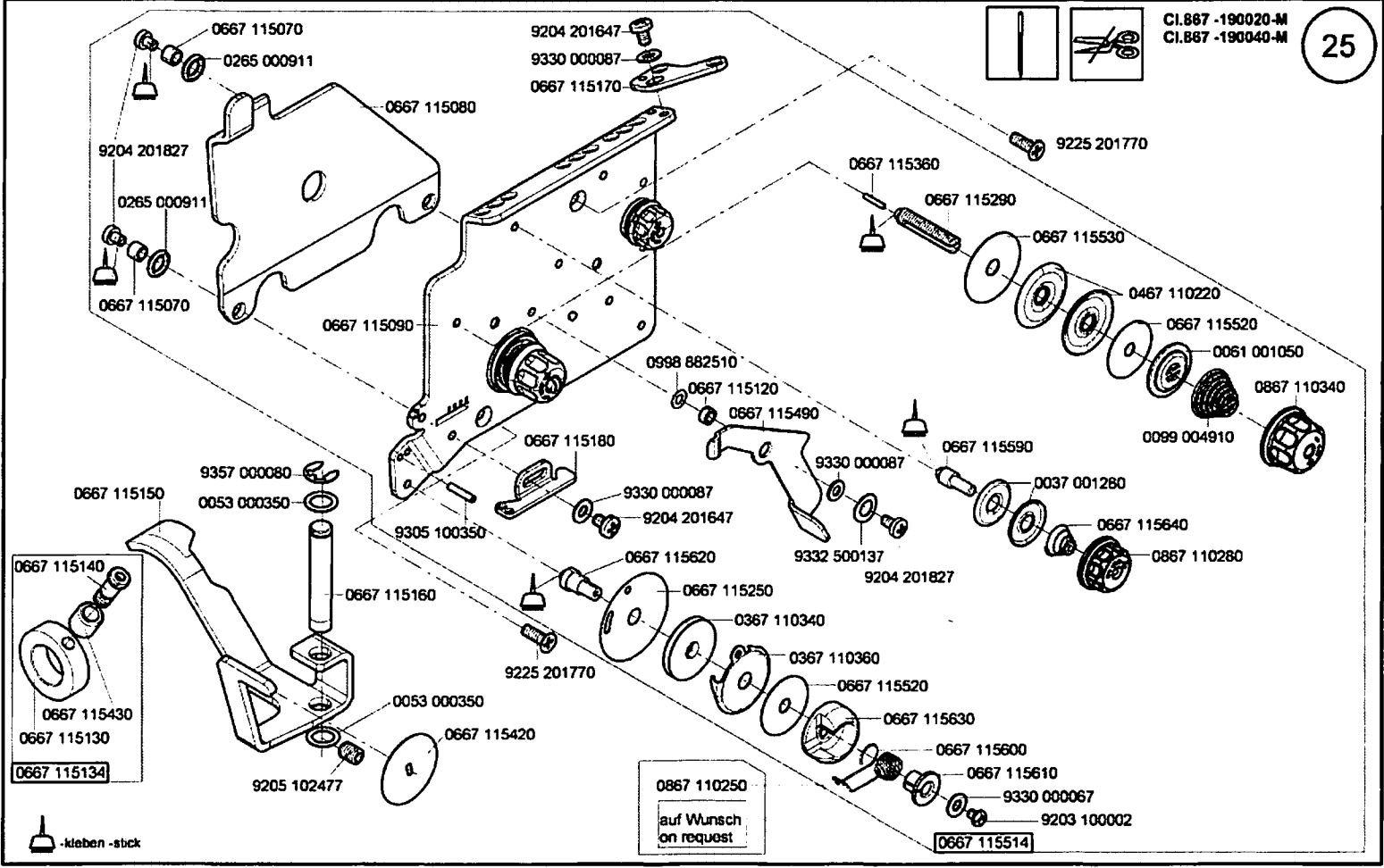

Cl. 867 - M Standard

CI.867 -160322-M
CI.867 -190322-M
CI.867 -190342-M
CI.867 -190425-M
CI.867 -190445-M

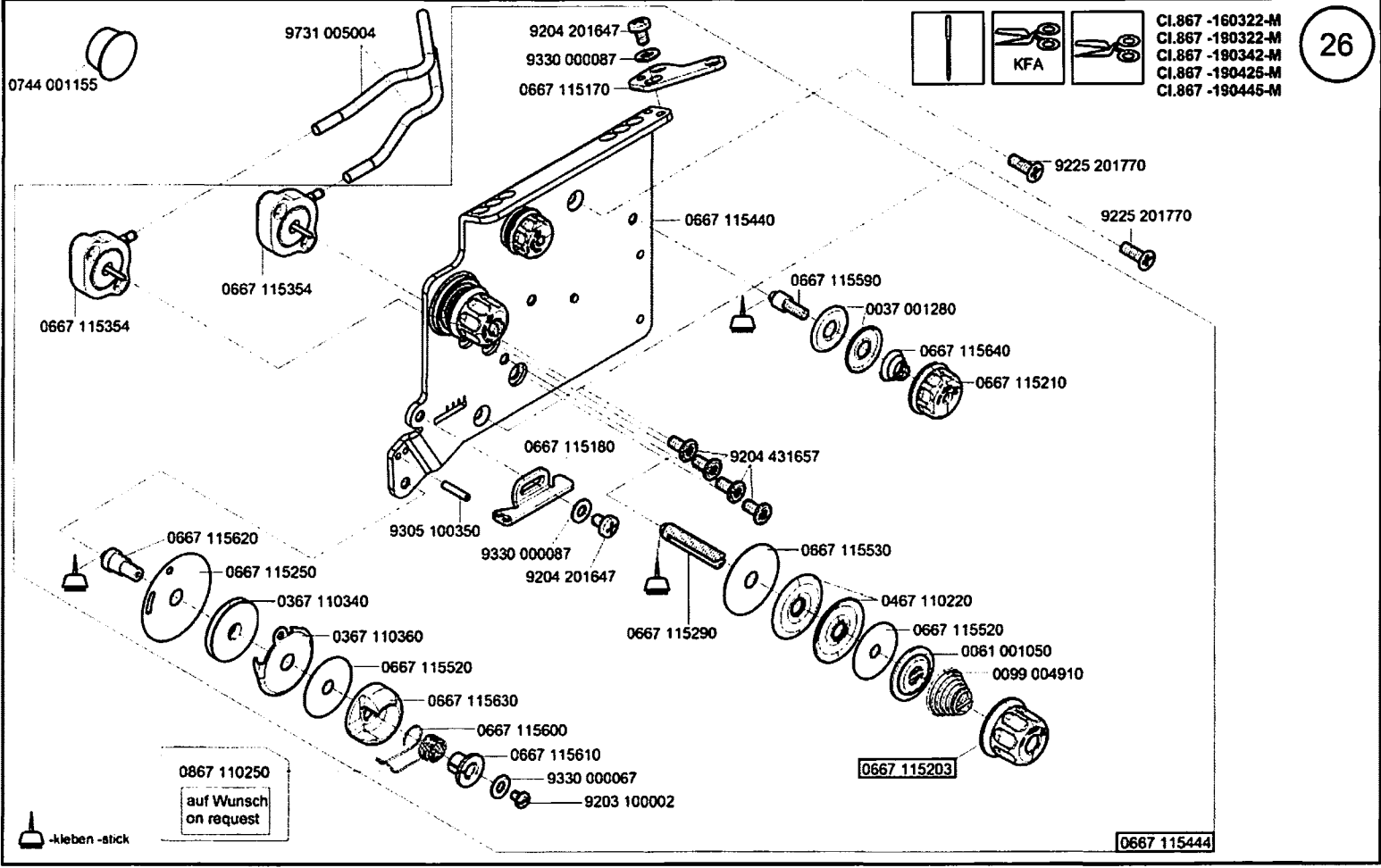

CI. 867 - M Standard

Ausgabe/Edition 10.2017

CI.867 -160122-M
CI.867 -190122-M
CI.867 -190125-M
CI.867 -190142-M
CI.867 -190145-M

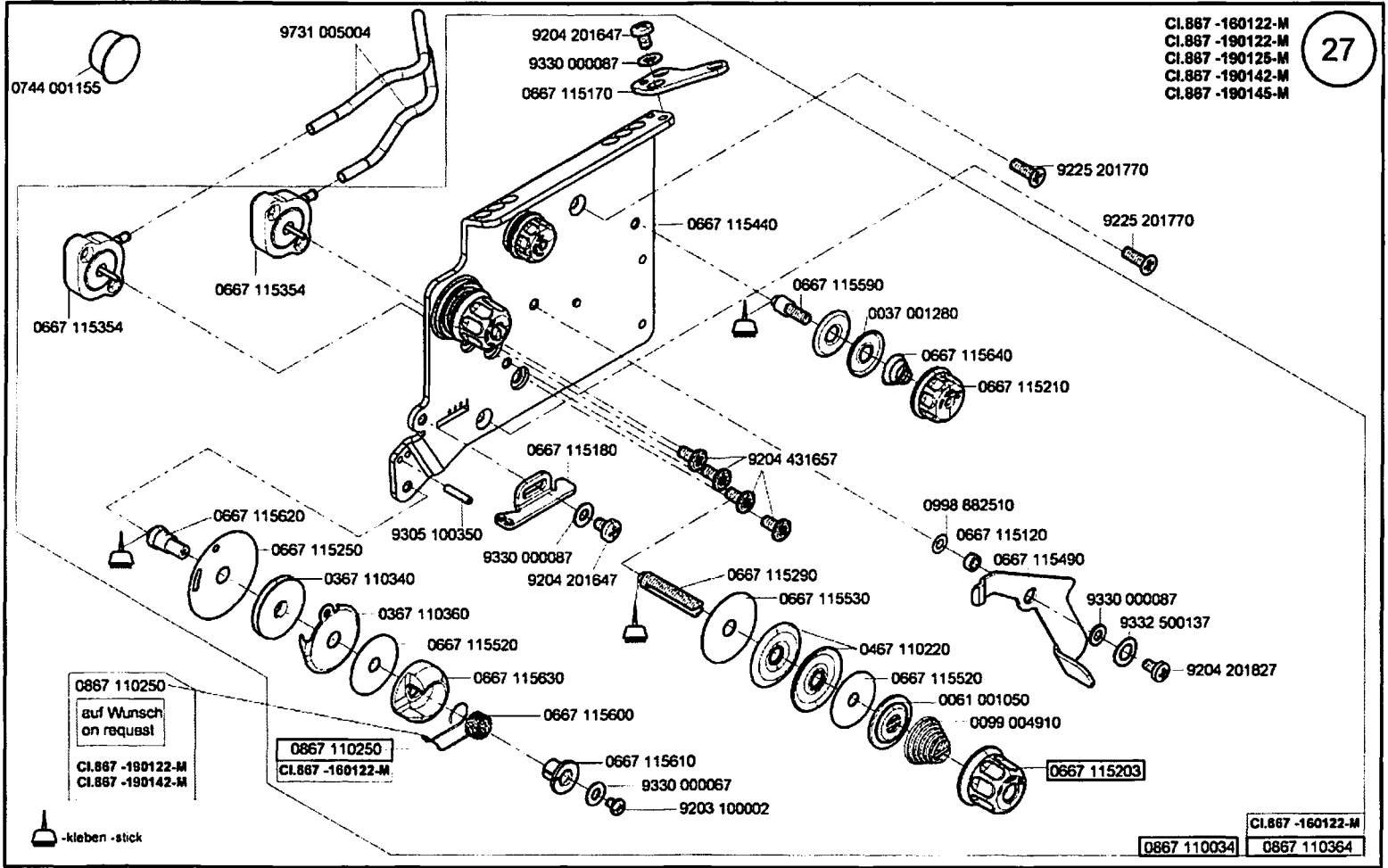

CI. 867 - M Standard

Ausgabe/Edition 12.2012

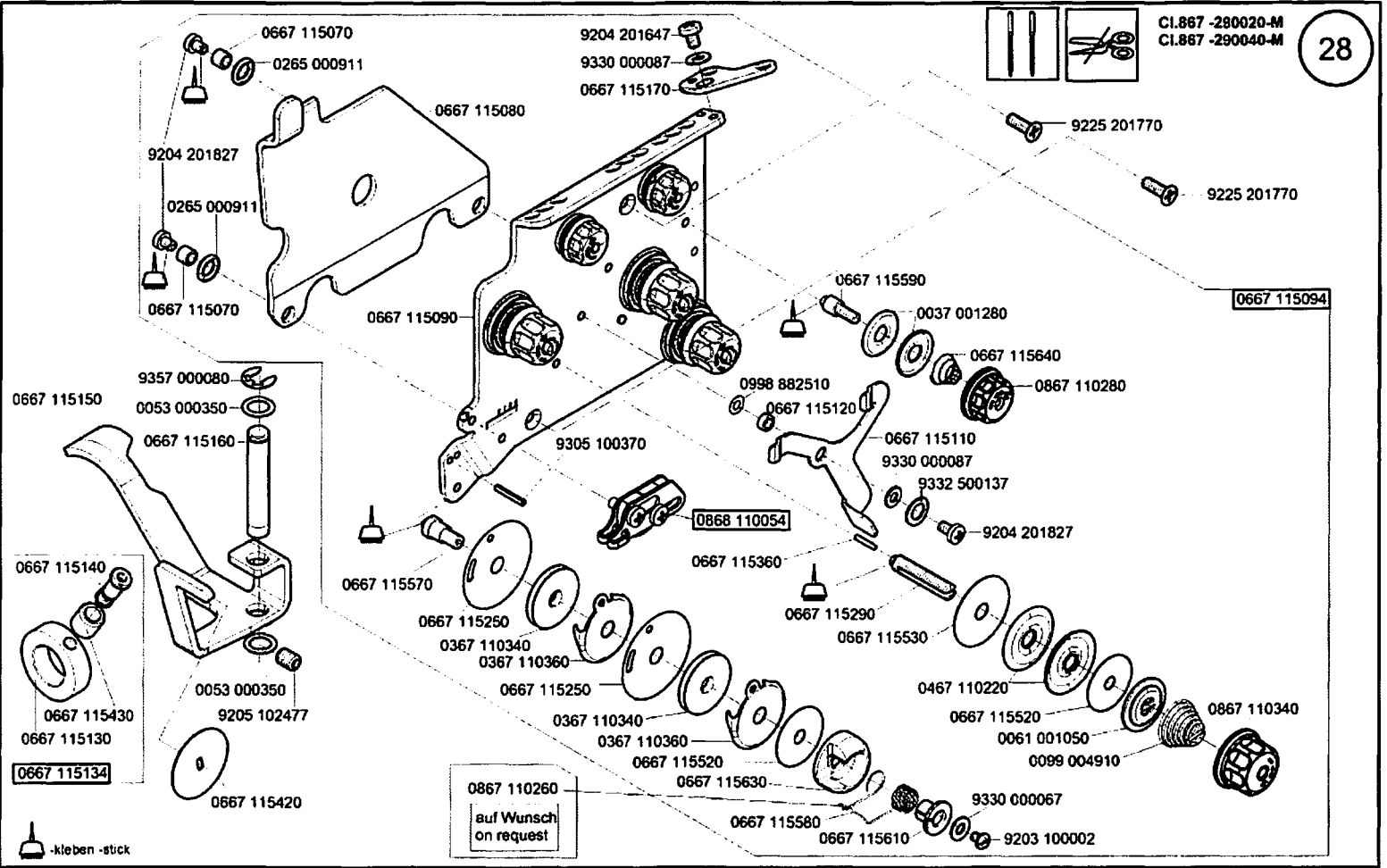

CI. 867 - M Standard

Ausgabe/Edition 1.2015

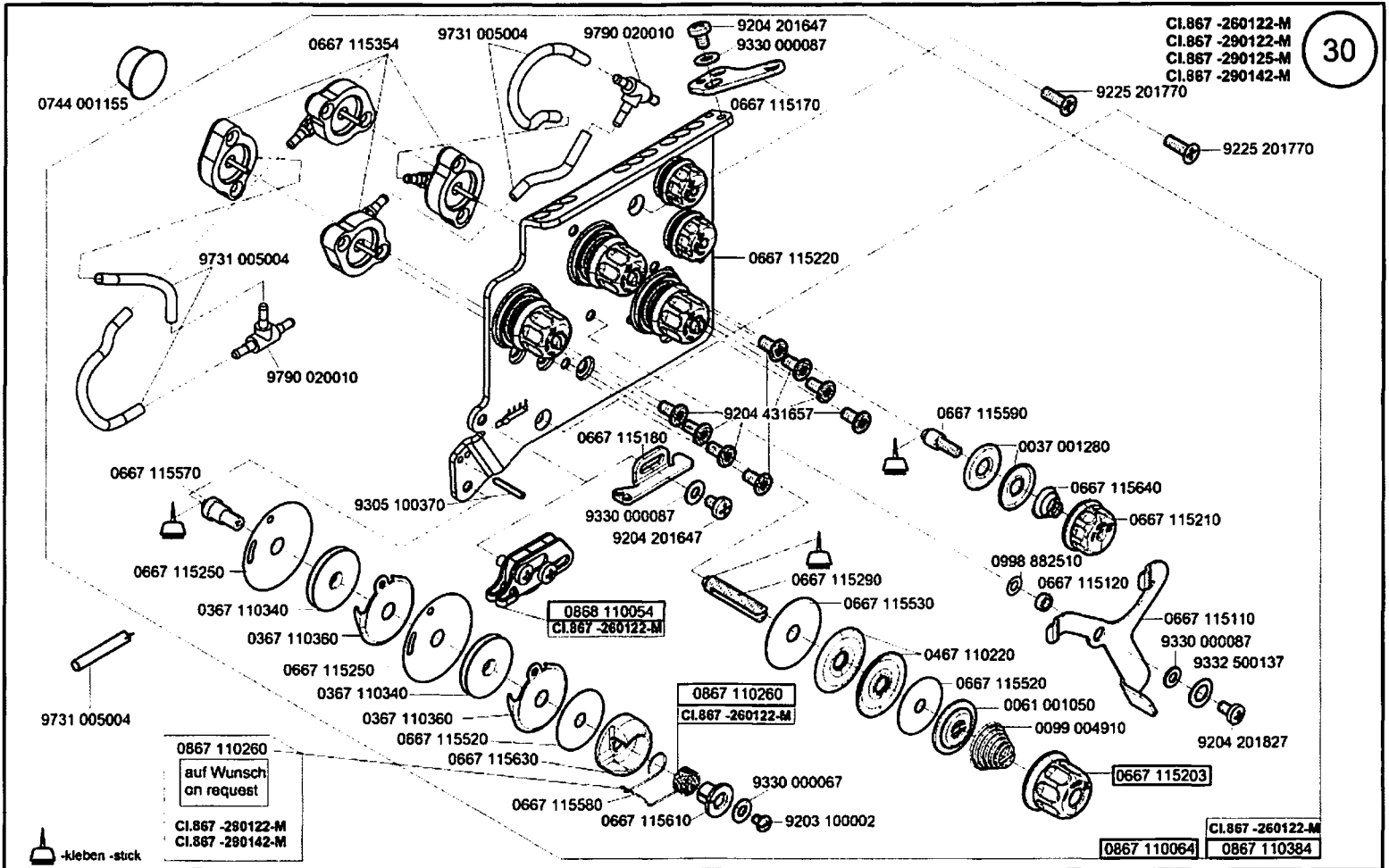

CI. 867 - M Standard

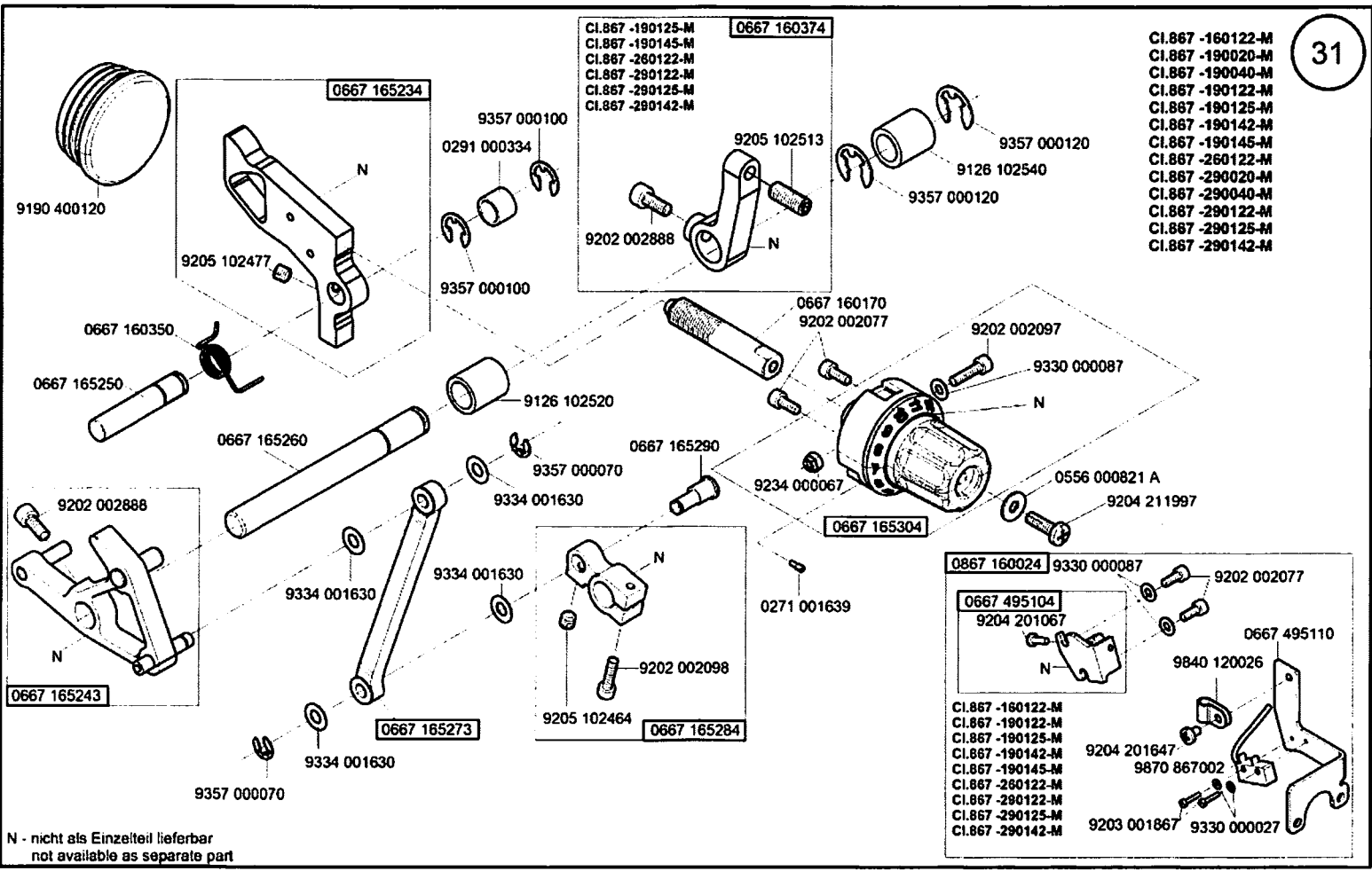

N - nicht als Einzelteil lieferbar
not available as separate part

CI. 867 - M Standard

Ausgabe/Edition 11.2018

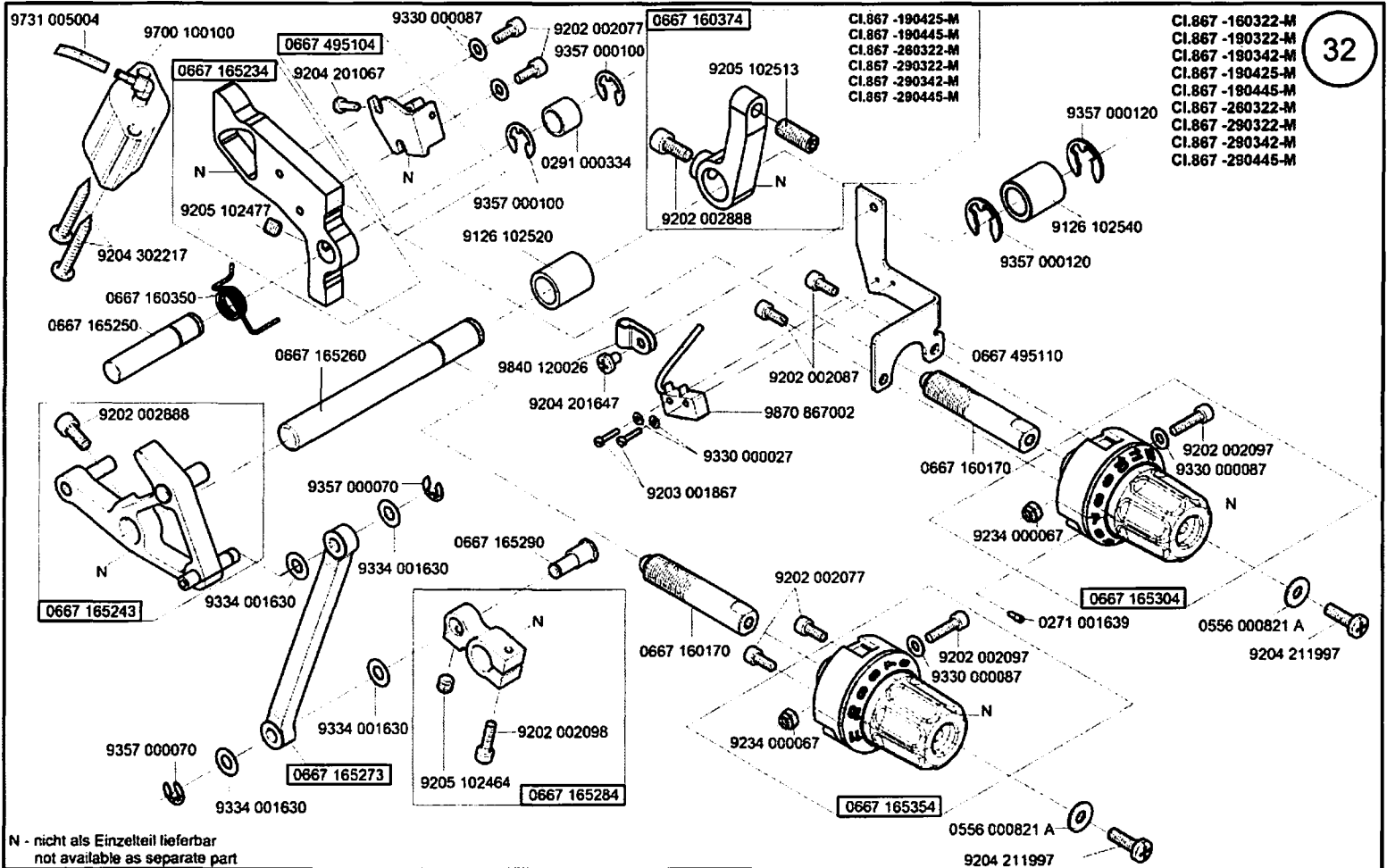

CI. 867 - M Standard

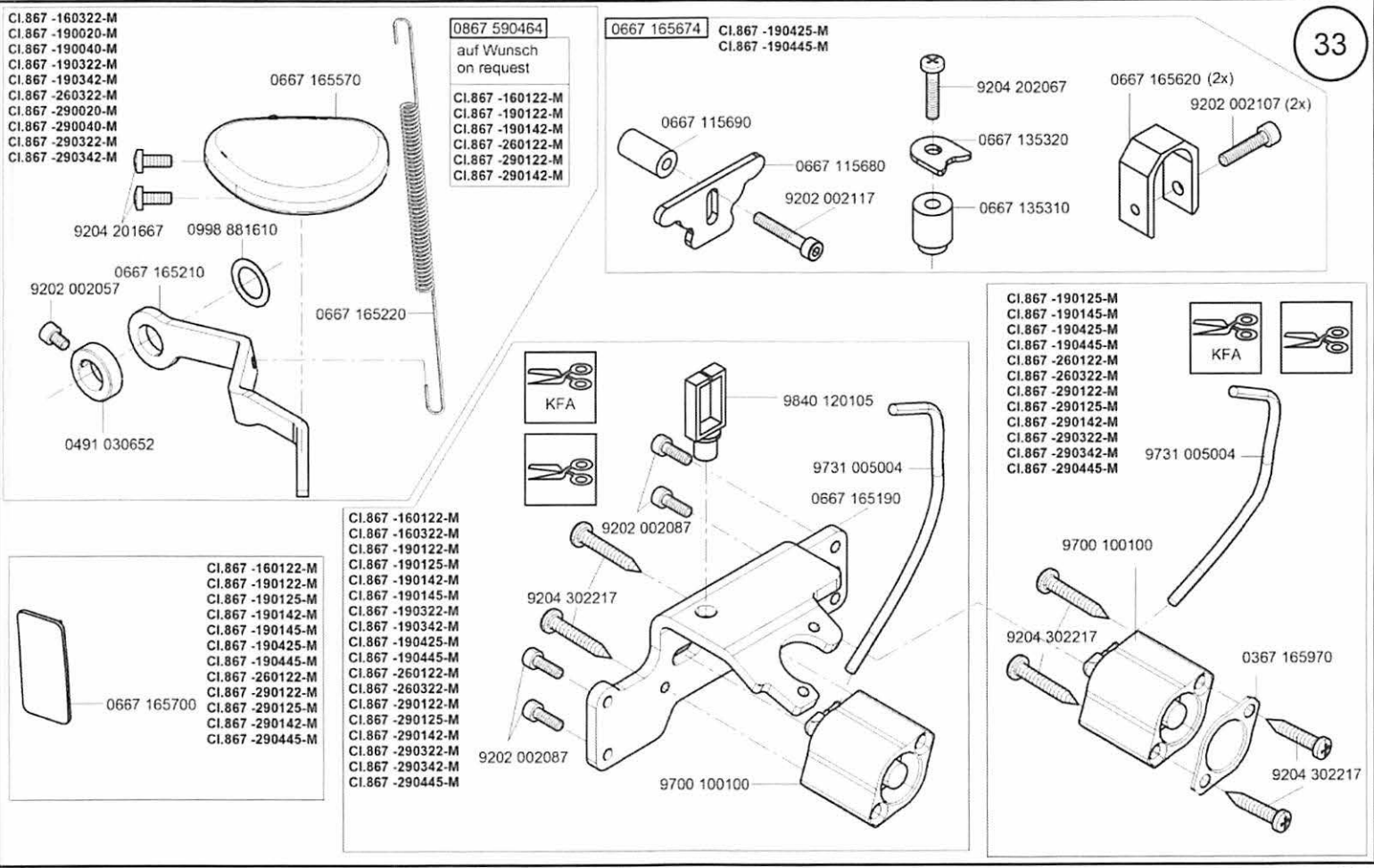

CI. 867 - M Standard

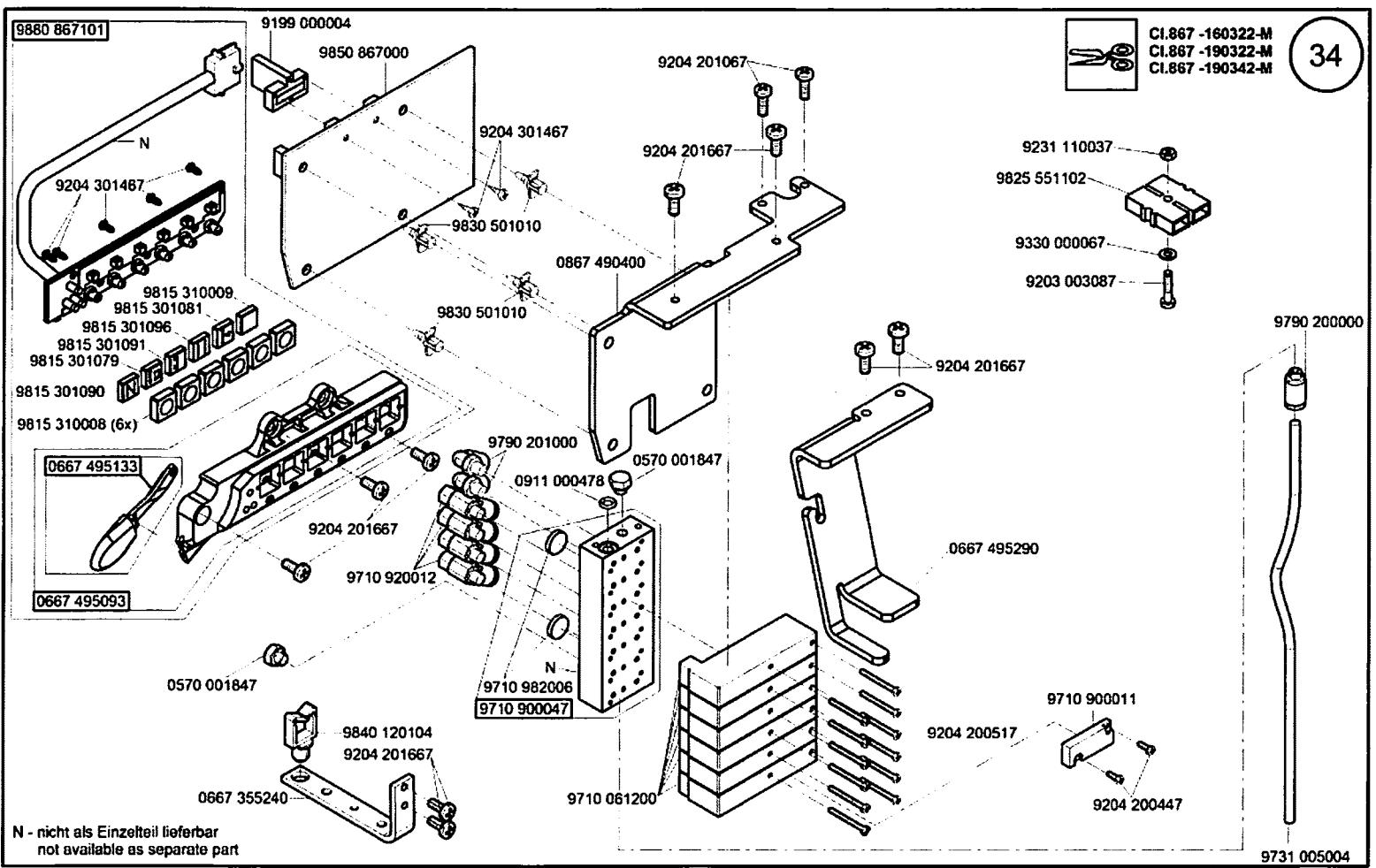

CI. 867 - M Standard

Ausgabe/Edition 10.2017

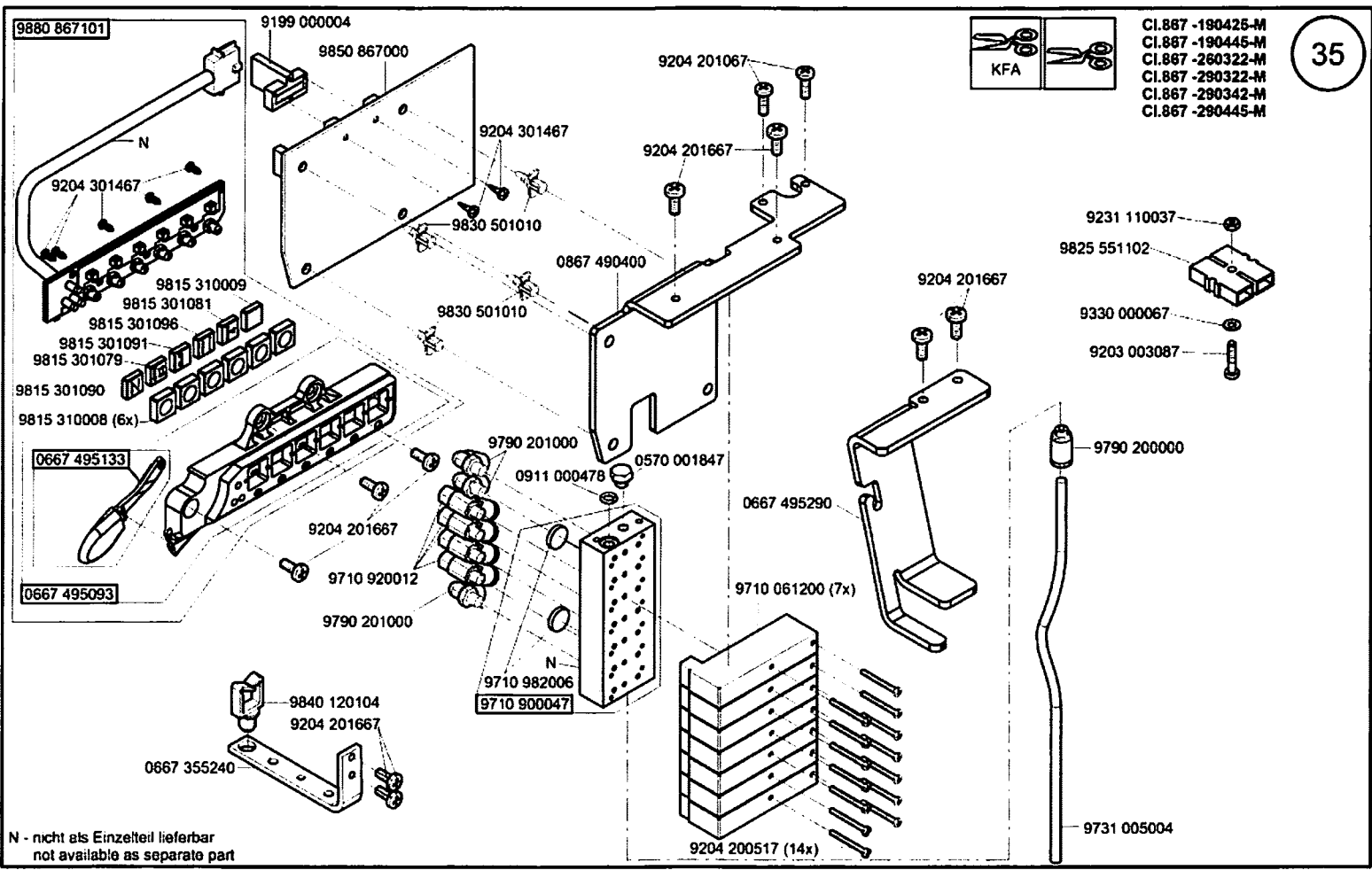

CI. 867 - M Standard

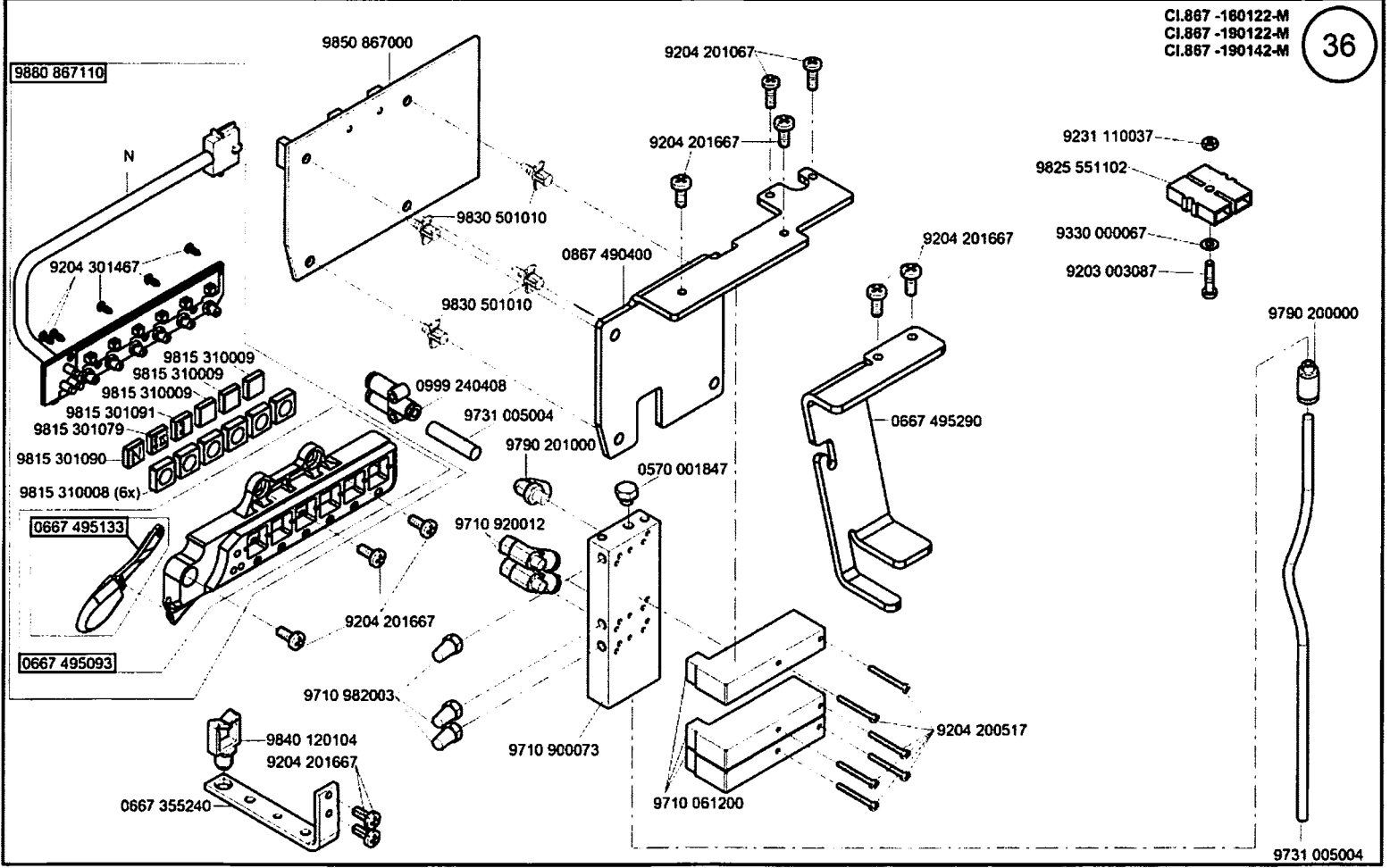

Cl. 867 - M Standard

CI.867 -190125-M
CI.867 -190145-M
CI.867 -260122-M
CI.867 -290125-M
CI.867 -290142-M

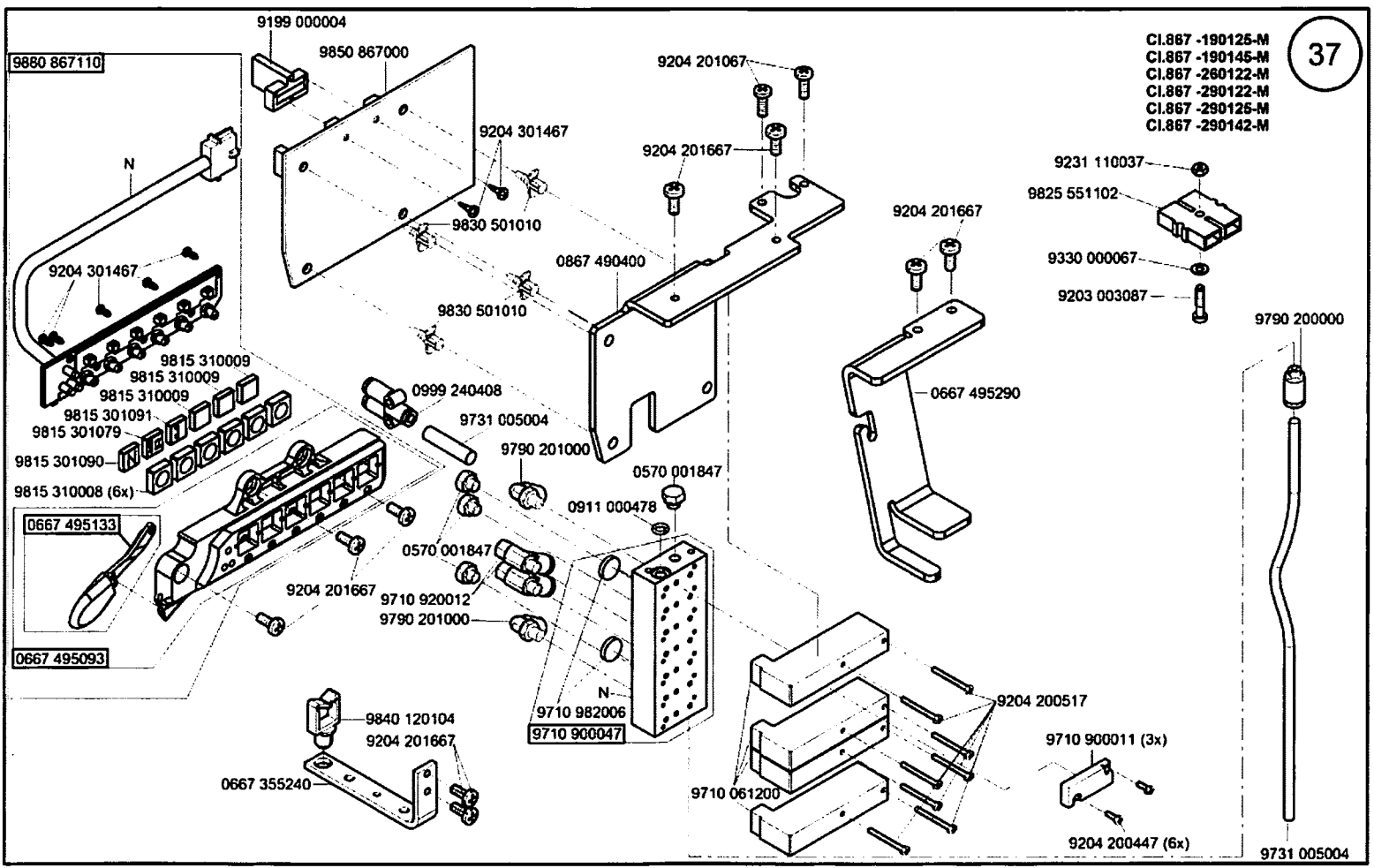

CI. 867 - M Standard

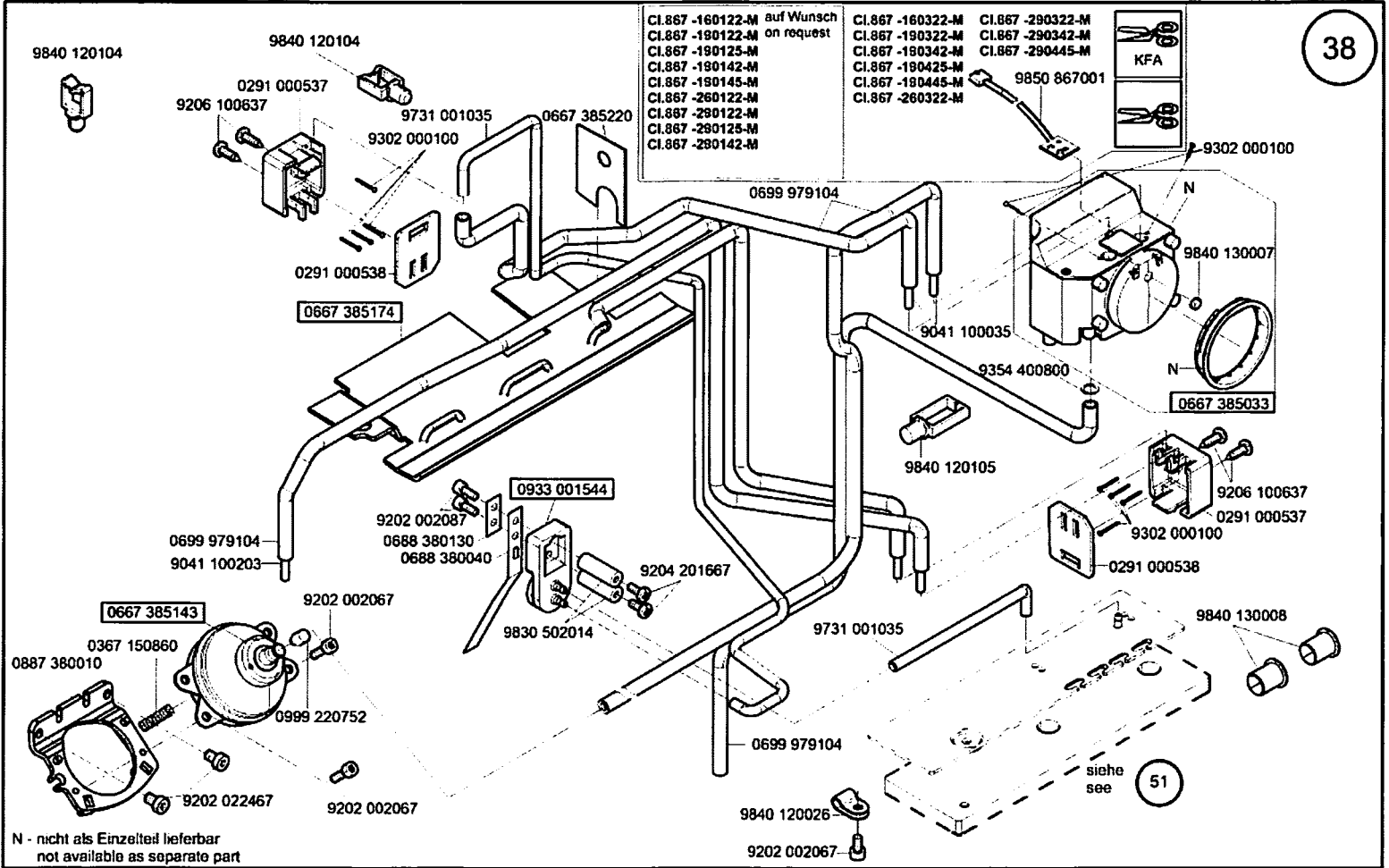

CI. 867 - M Standard

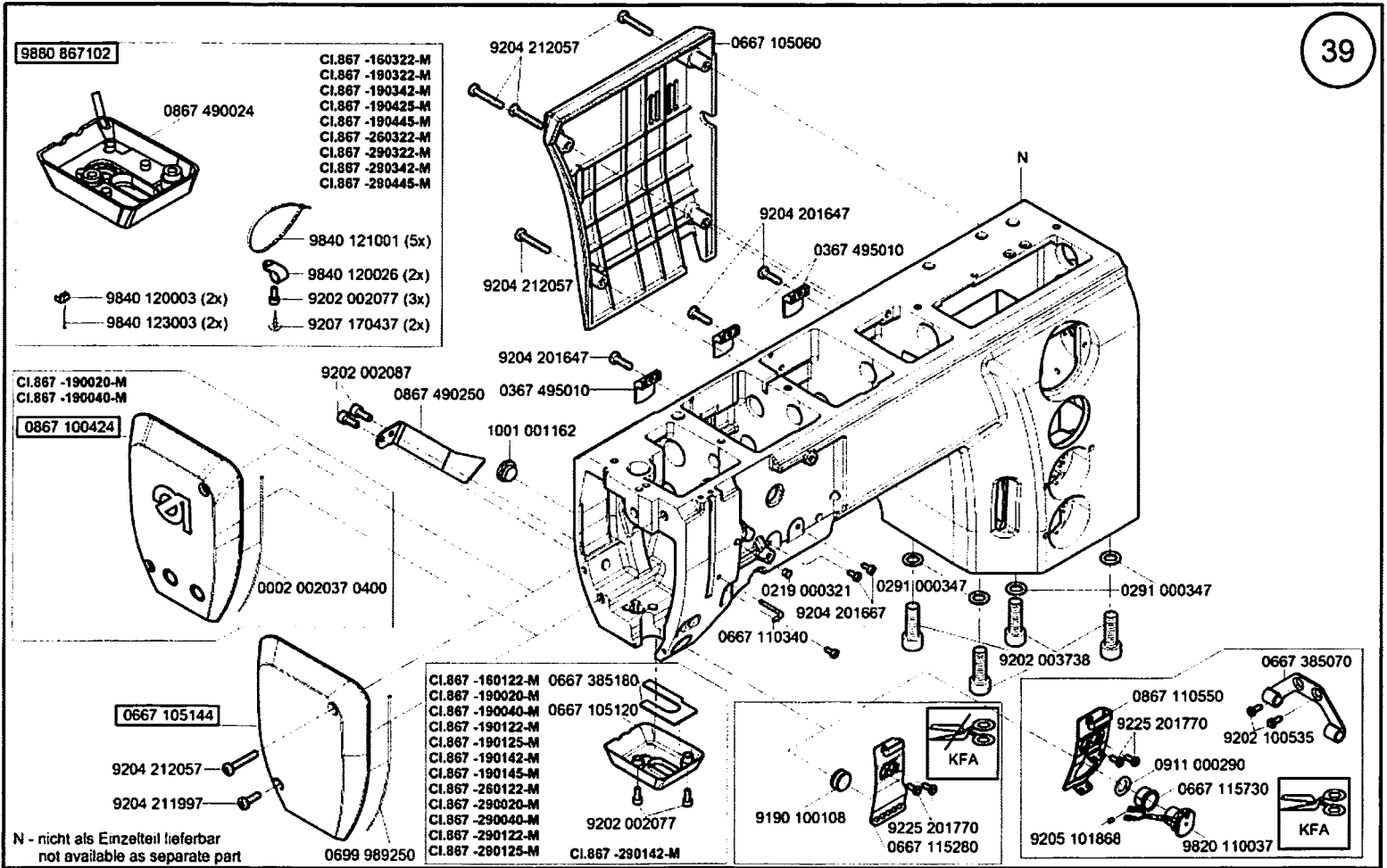

CI. 867 - M Standard

- CI.867 -160122-M
- CI.867 -190020-M
- CI.867 -190040-M
- CI.867 -190122-M
- CI.867 -190125-M
- CI.867 -190142-M
- CI.867 -190145-M
- CI.867 -260122-M
- CI.867 -290020-M
- CI.867 -290040-M
- CI.867 -290122-M
- CI.867 -290125-M
- CI.867 -290142-M

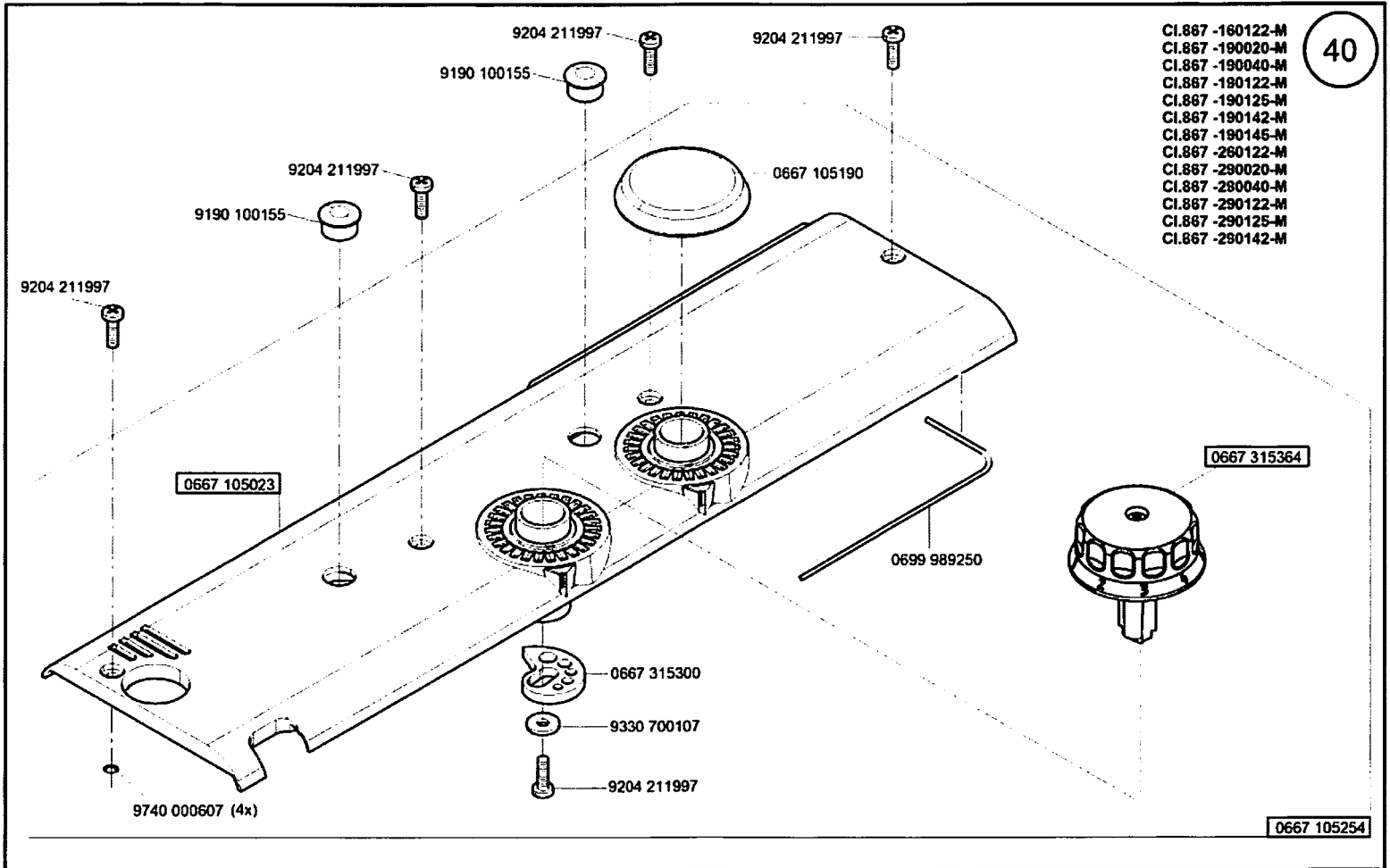

CI. 867 - M Standard

Ausgabe/Edition 11.2018

CI.867 -160322-M
CI.867 -190322-M
CI.867 -190342-M
CI.867 -260322-M
CI.867 -290322-M
CI.867 -290342-M

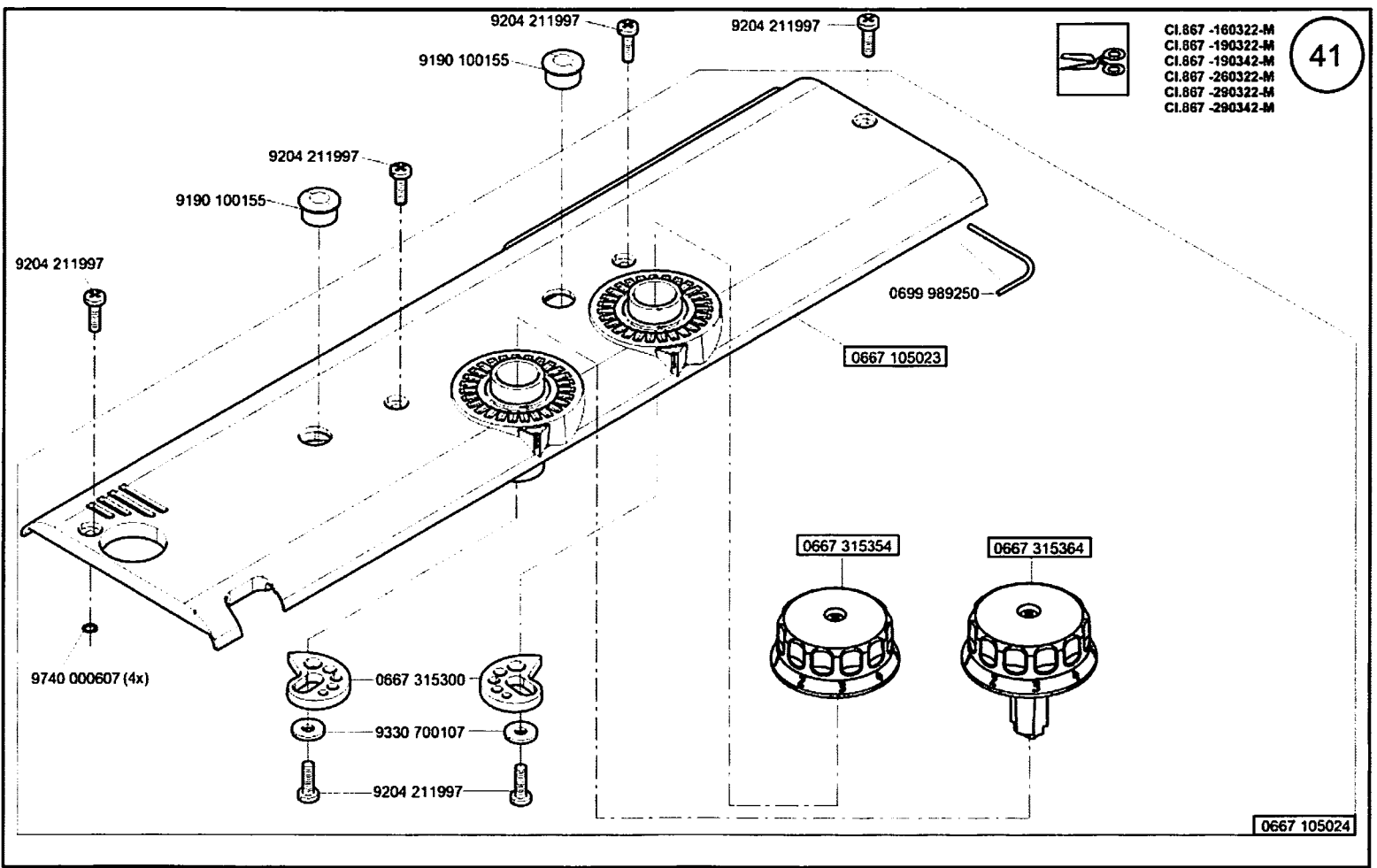

CI. 867 - M Standard

Ausgabe/Edition 10.2017

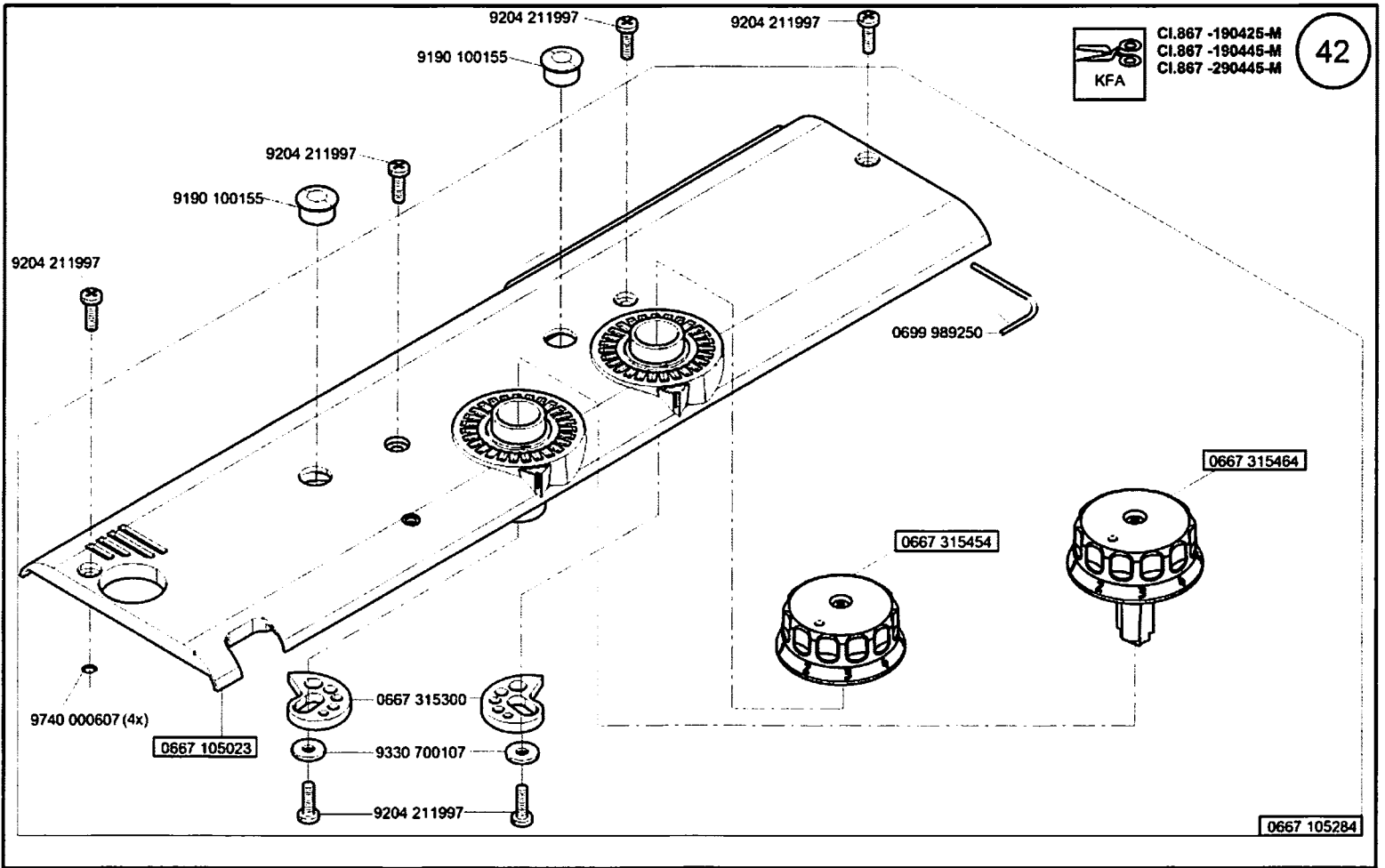

CI. 867 - M Standard

Ausgabe/Edition 11.2018

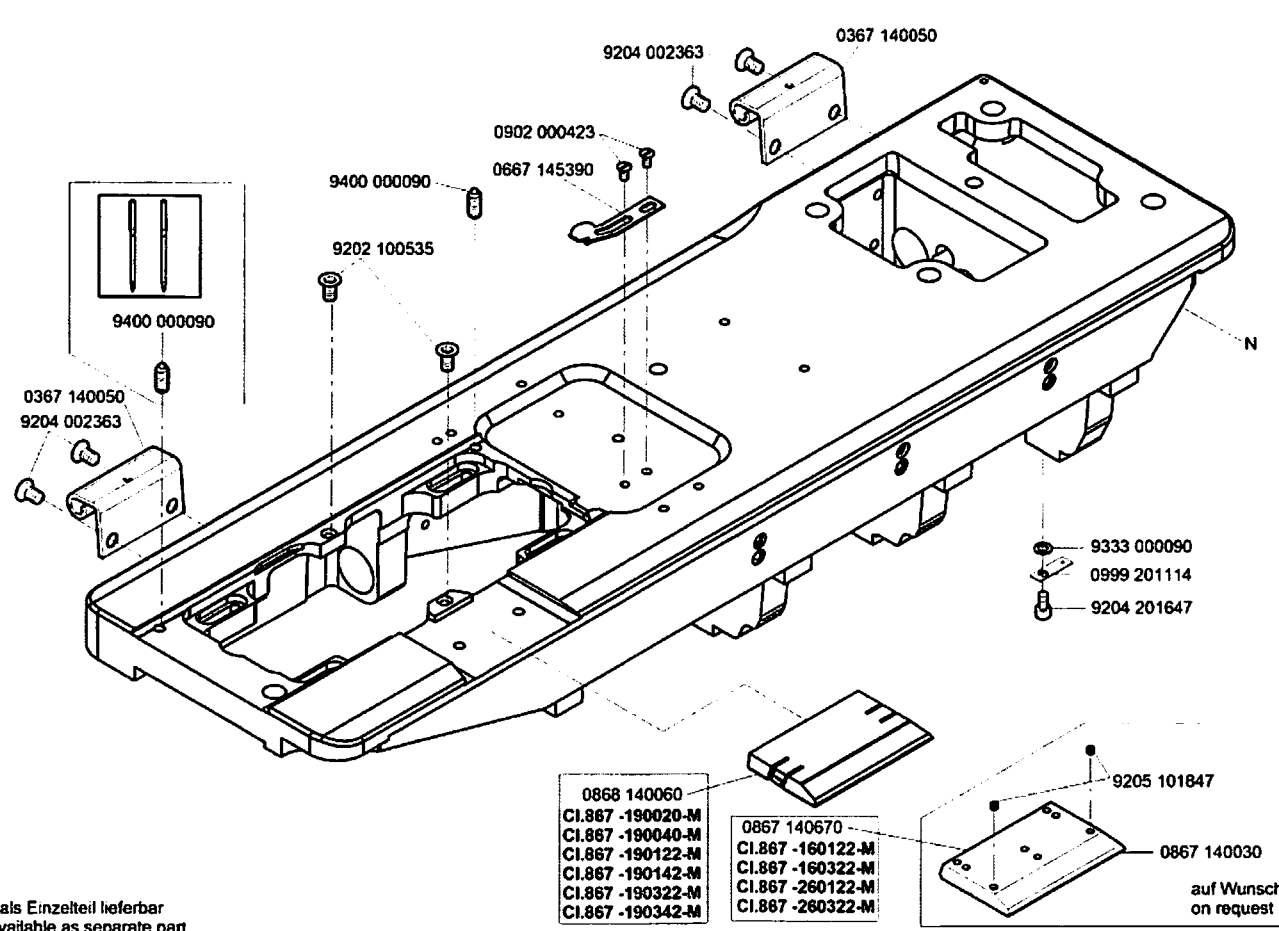

N - nicht als Einzelteil lieferbar
not available as separate part

- 0868 140060
- CI.867 -190020-M
- CI.867 -190040-M
- CI.867 -190122-M
- CI.867 -190142-M
- CI.867 -190322-M
- CI.867 -190342-M

- 0867 140670
- CI.867 -160122-M
- CI.867 -160322-M
- CI.867 -260122-M
- CI.867 -260322-M

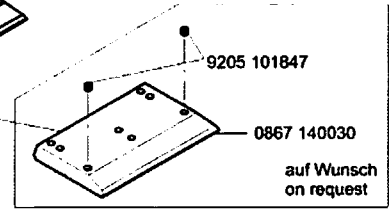

CI. 867 - M Standard

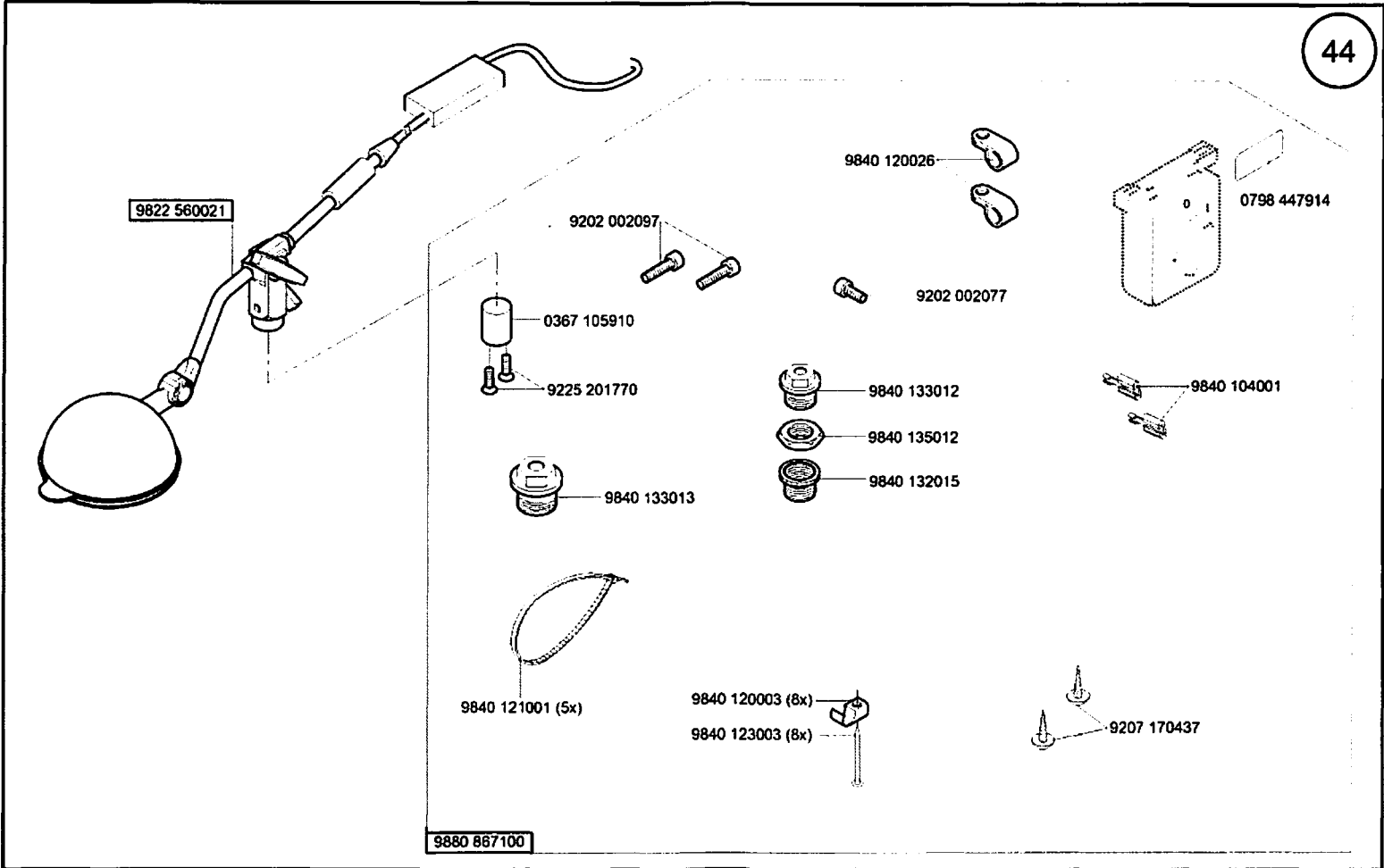

Cl. 867 - M Standard

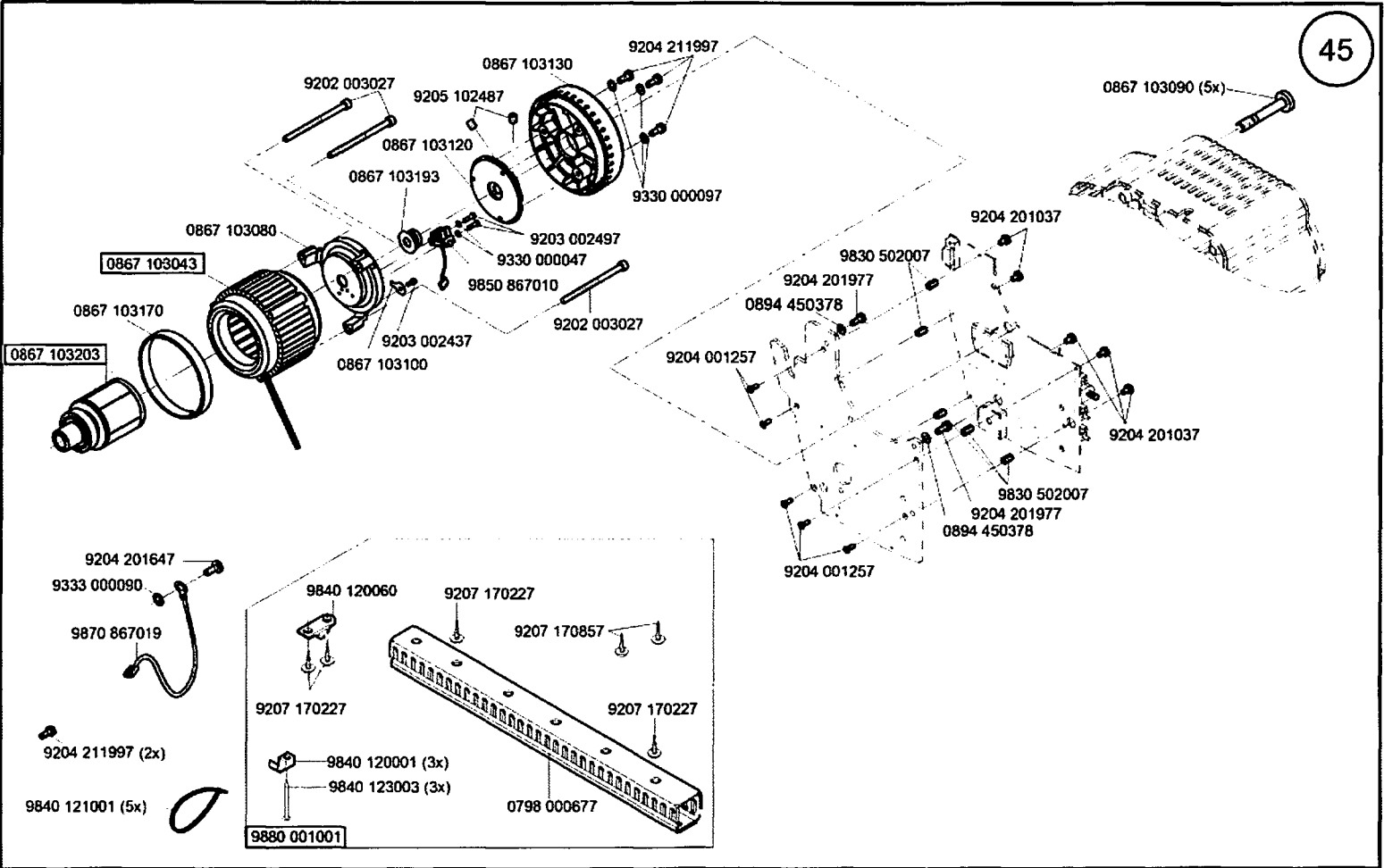

CI. 867 - M Standard

CI.867 -190020-M
CI.867 -190040-M
CI.867 -290020-M
CI.867 -290040-M

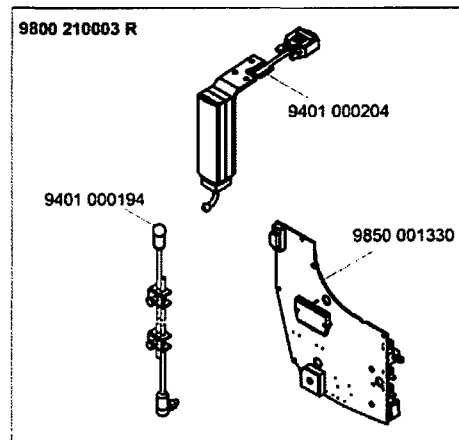
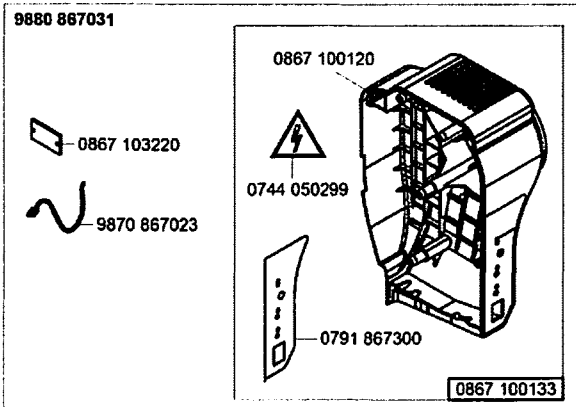
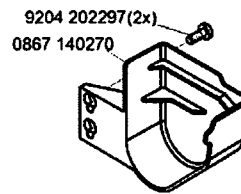
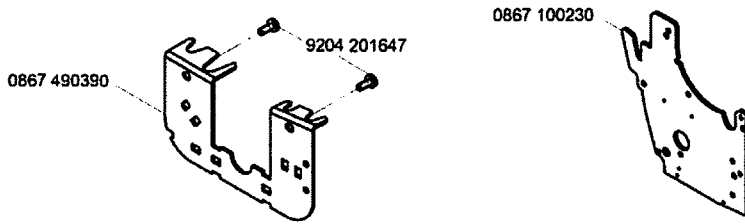

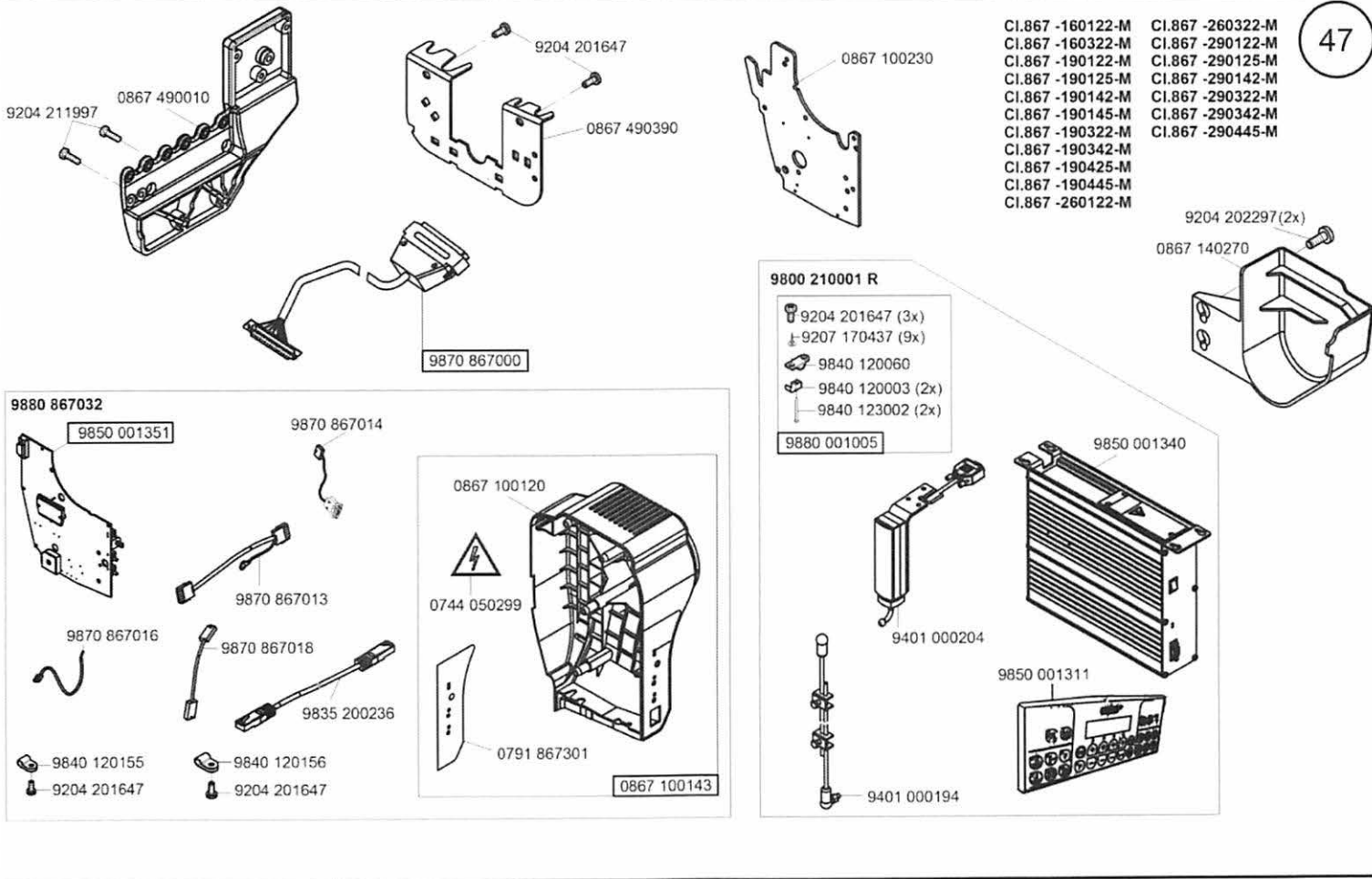

CI. 867 - M Standard

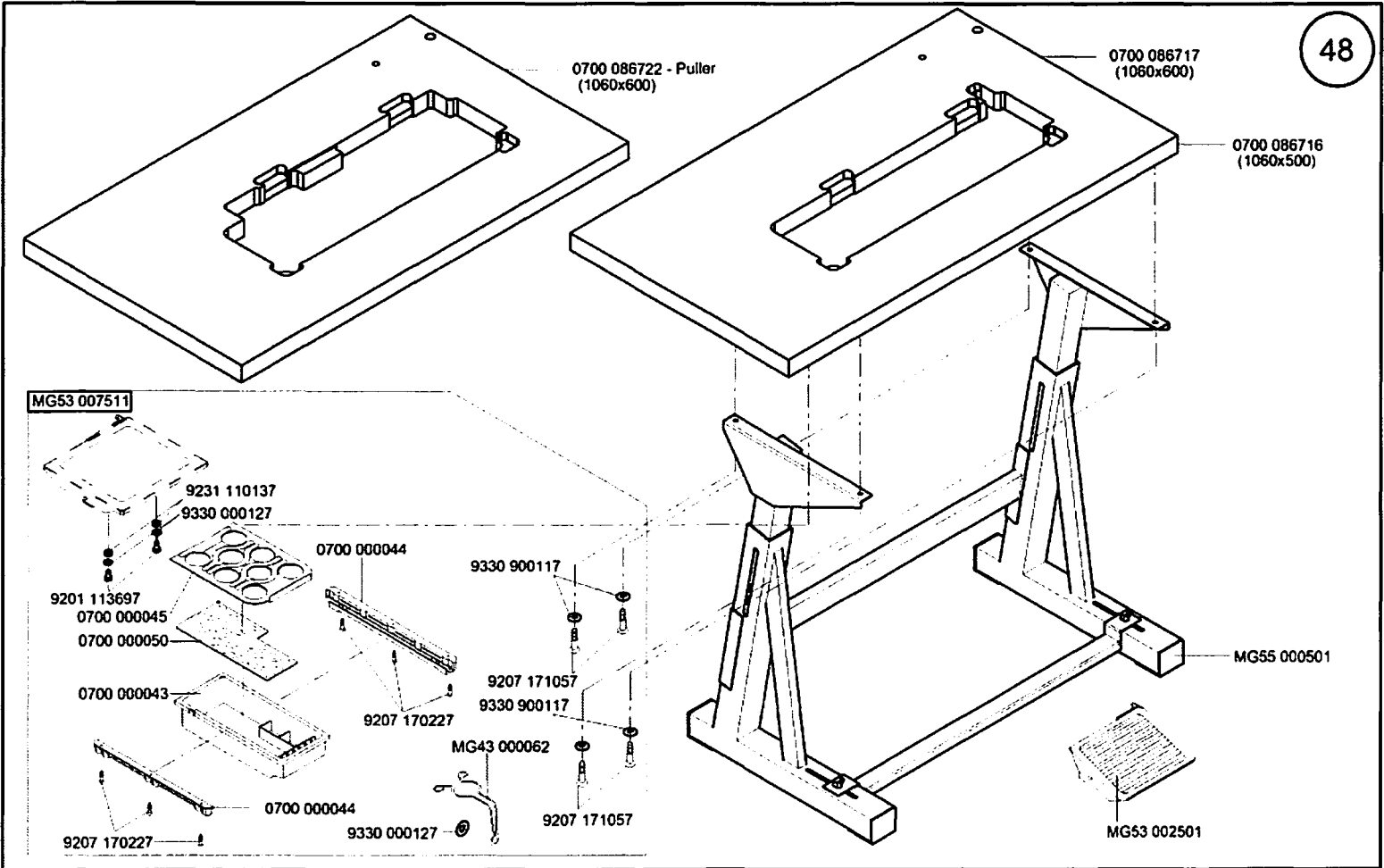

CI. 867 - M Standard

Ausgabe/Edition 5.2015

auf Wunsch
on request

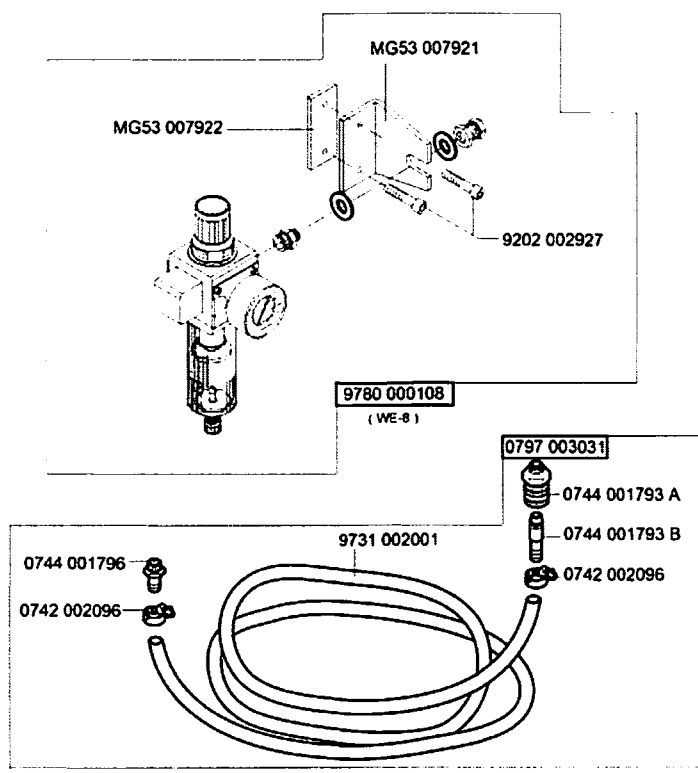

Cl. 867 - M Standard

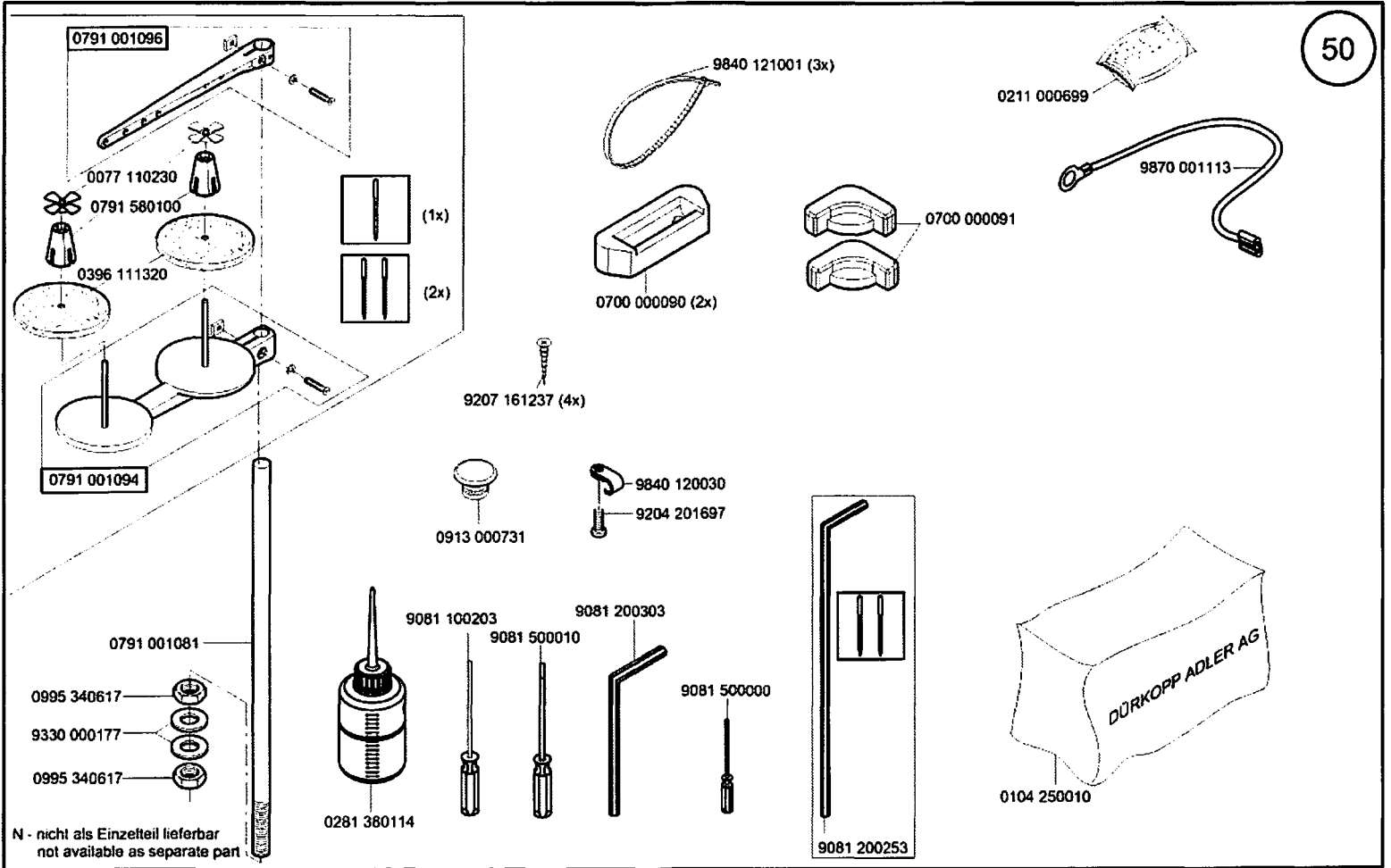

Cl. 867 - M Standard

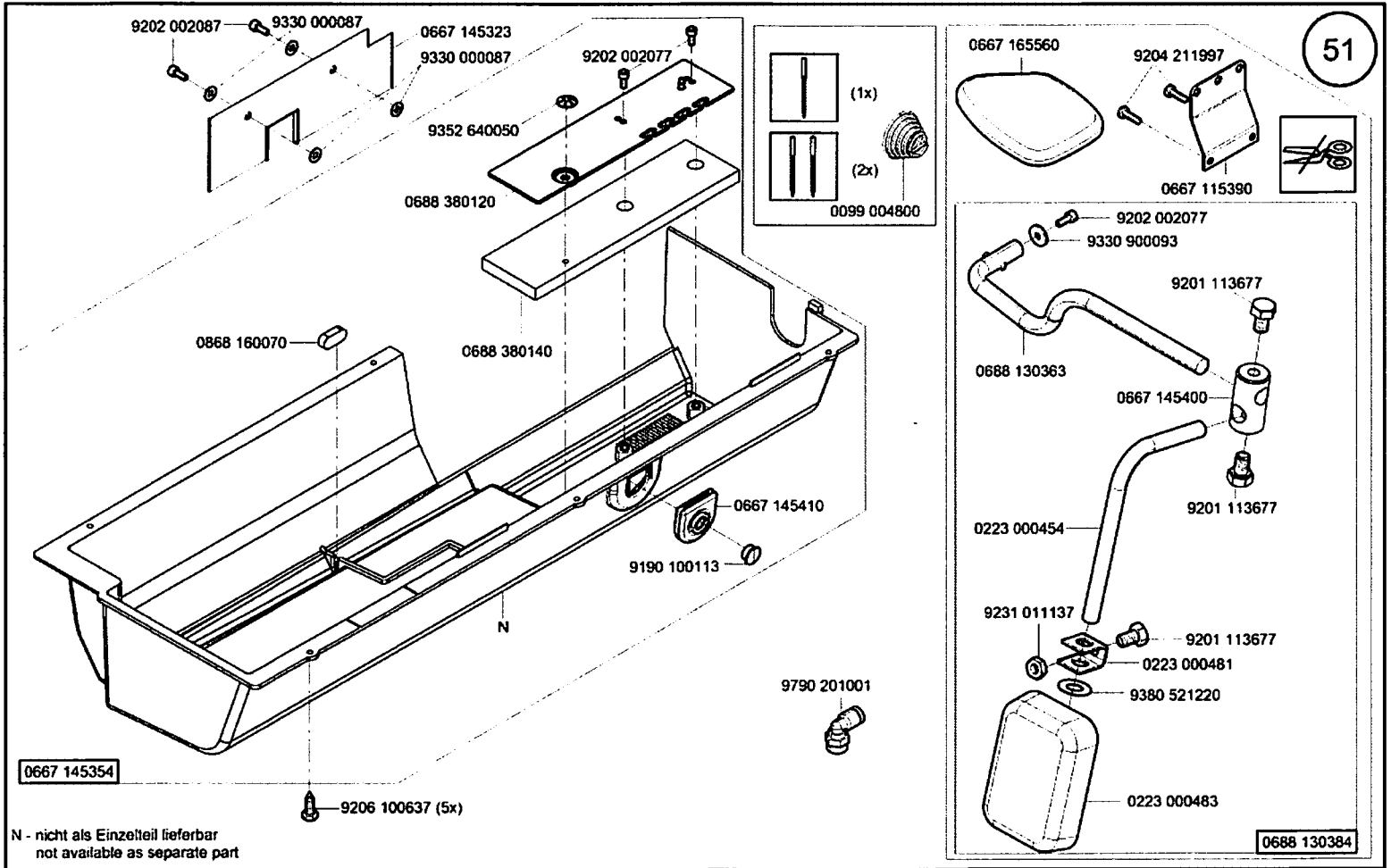

CI. 867 - M Standard

Ausgabe/Edition 10.2015

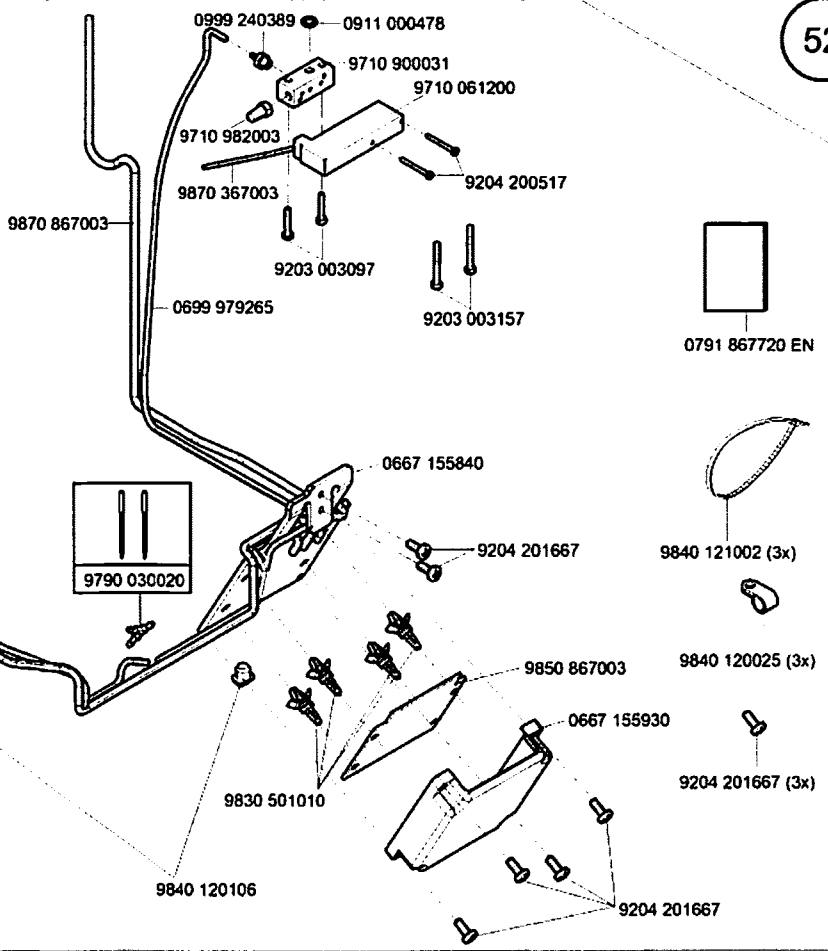
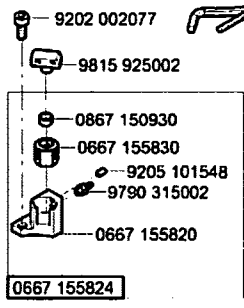
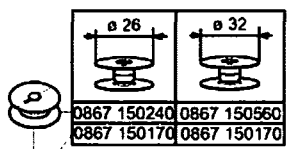
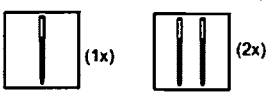
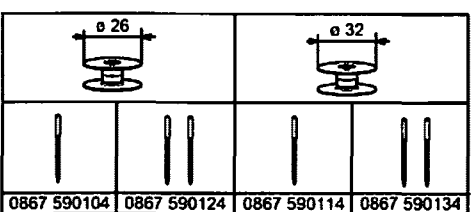

Cl. 867 - M Standard

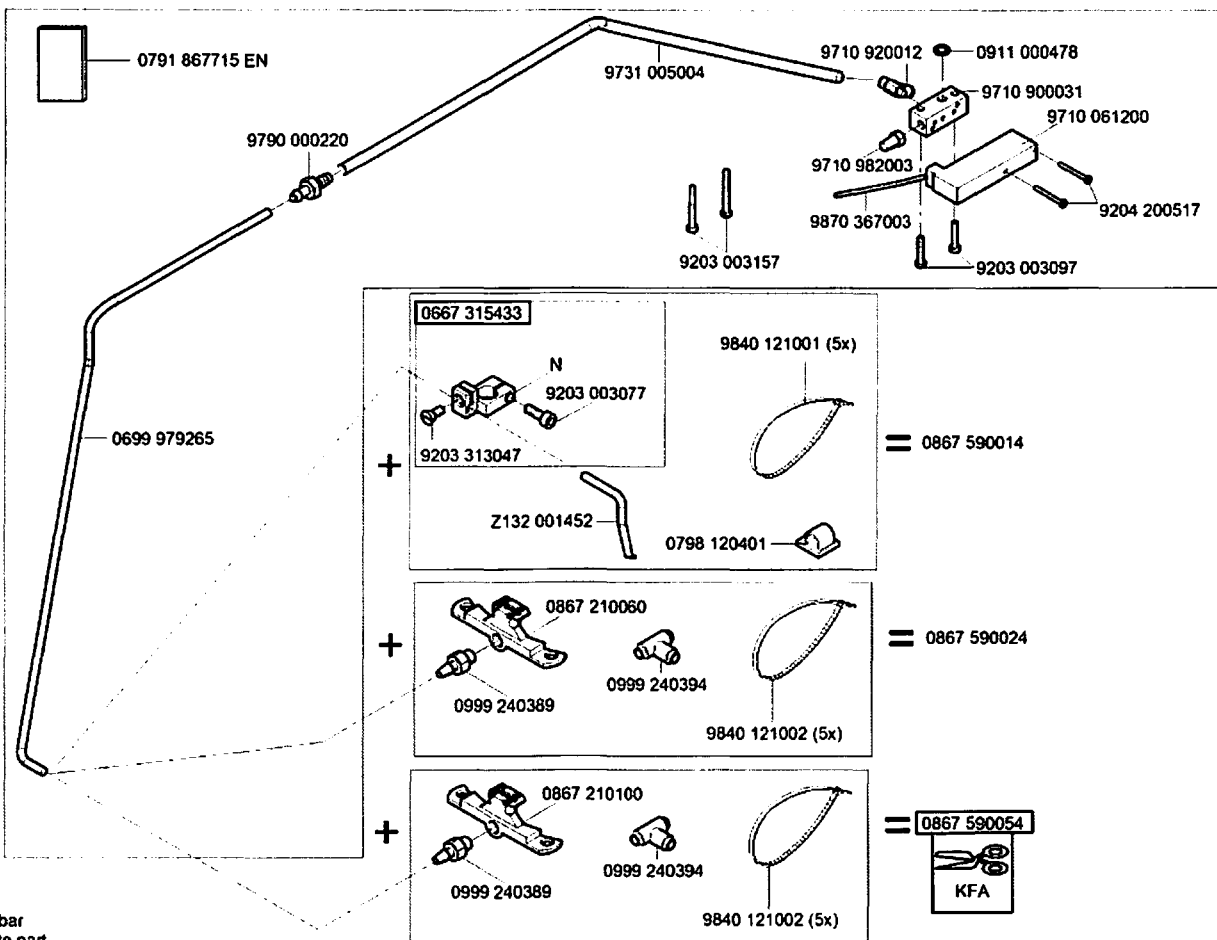

N - nicht als Einzelteil lieferbar
not available as separate part

Cl. 867 - M Standard

Ausgabe/Edition 1.2018

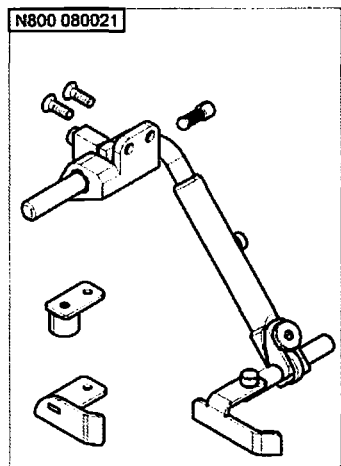
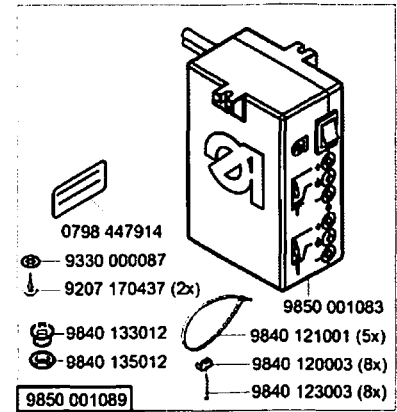
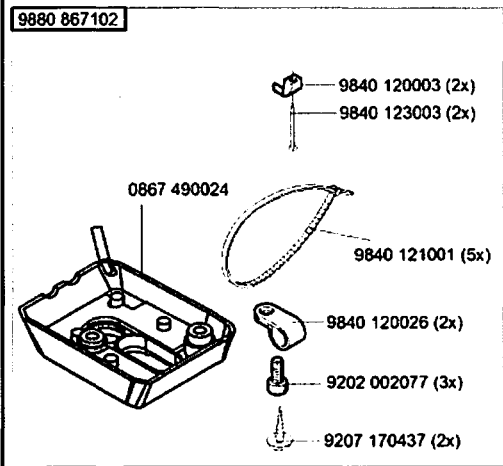
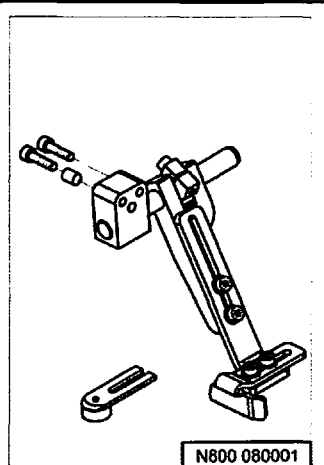
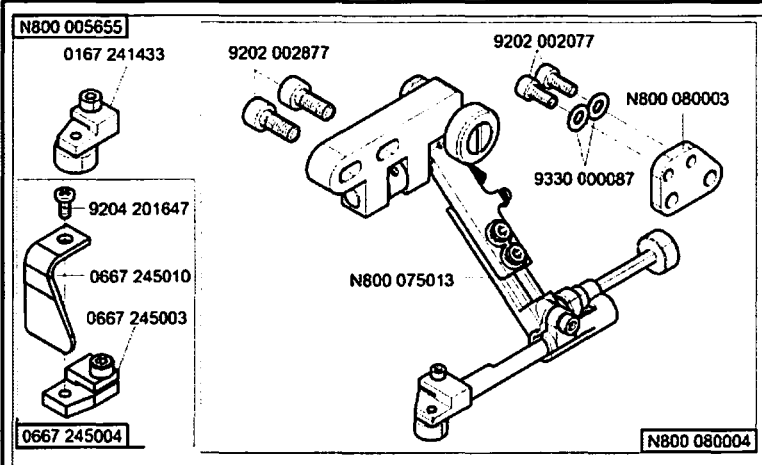

CI. 867 - M Standard

siehe Näherrichtungen Blatt 1
see sewing equipment page 1
0867 590064

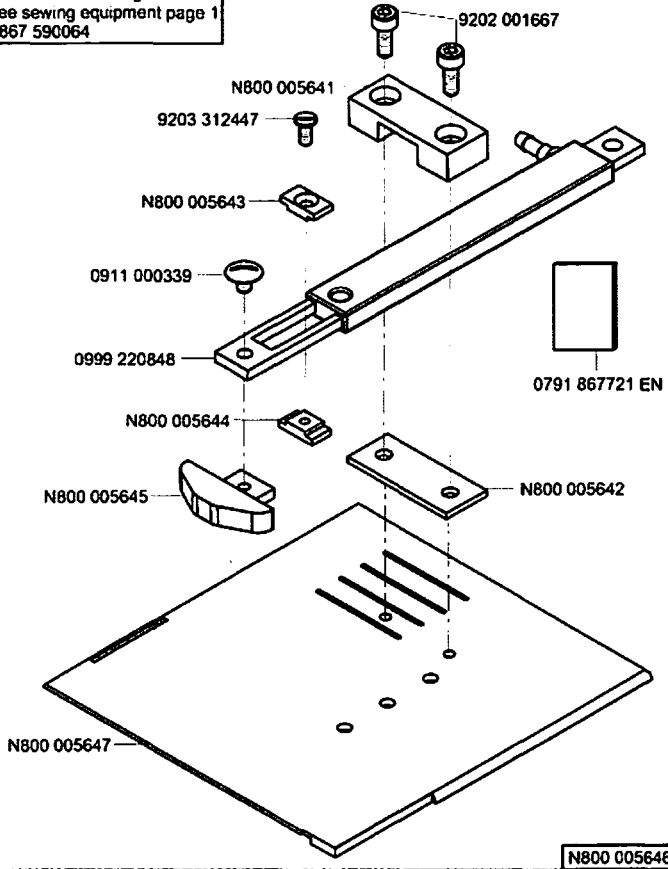

N800 005646

N - nicht als Einzelteil lieferbar
not available as separate part

siehe Näherrichtungen Blatt 1
see sewing equipment page 1
0867 590064

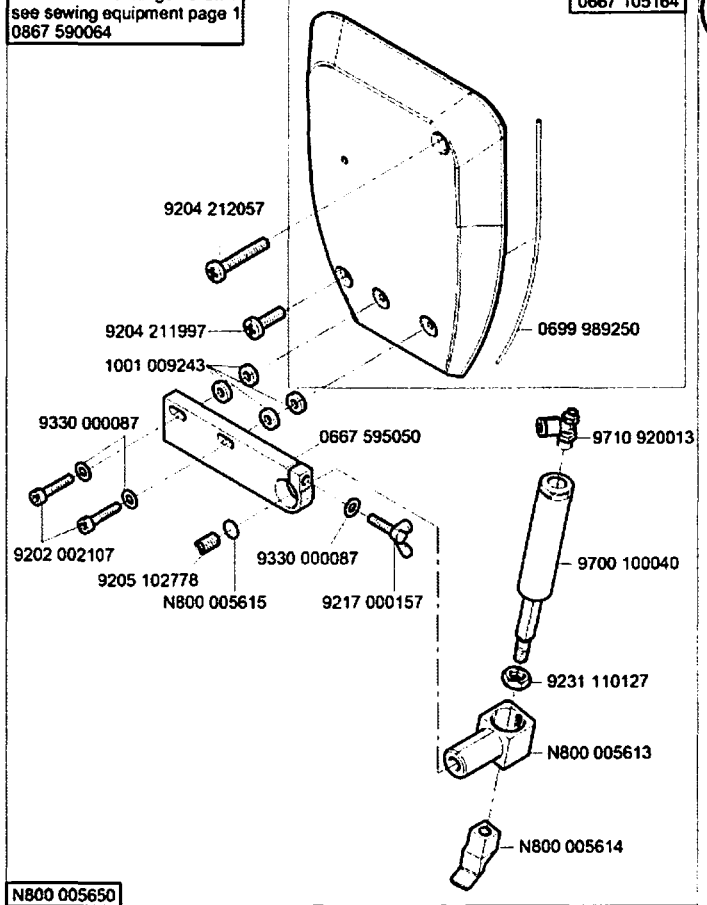

N800 005650

0667 105164

55

CI. 867 - M Standard

Ausgabe/Edition 8.2018

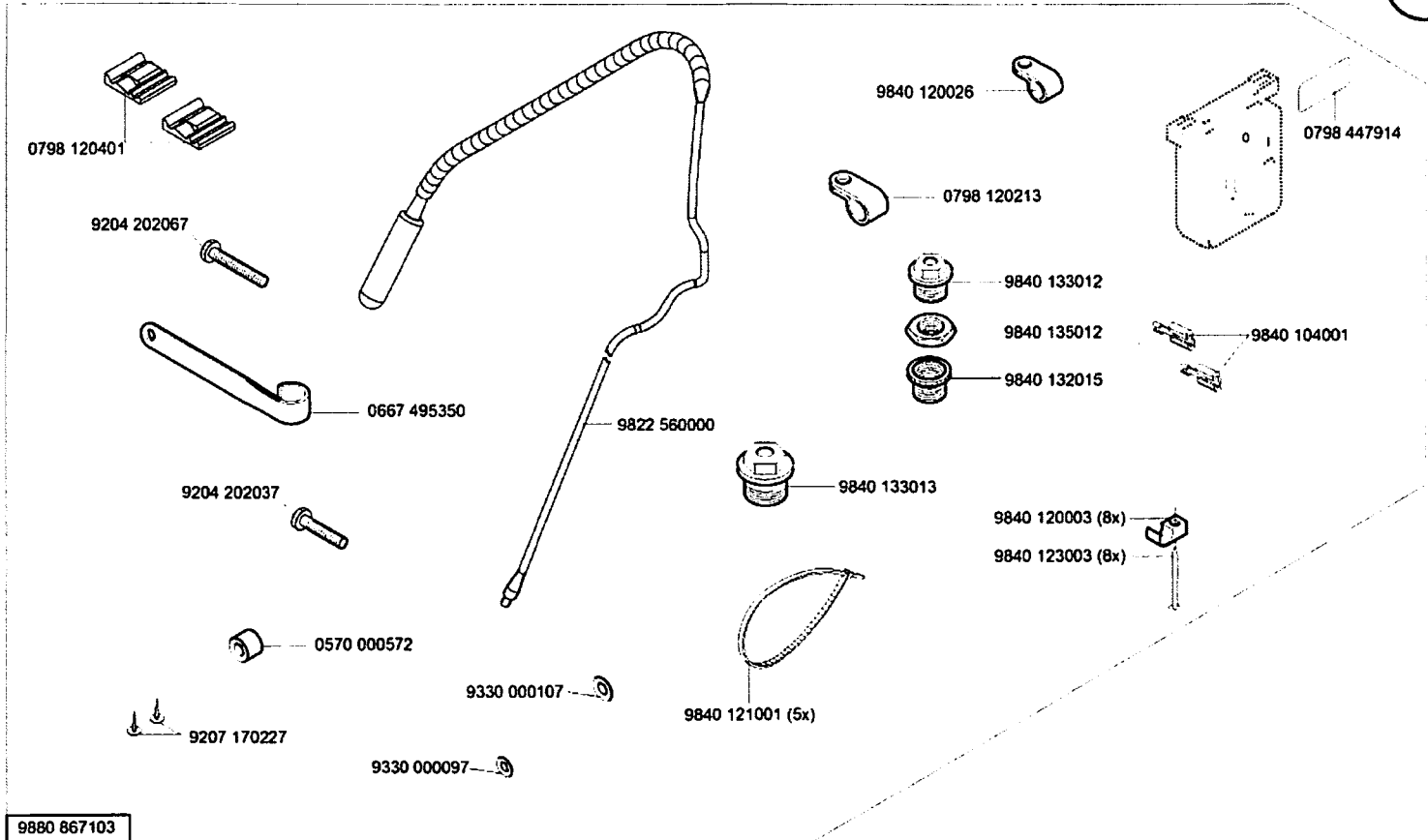

9880 867103

Cl. 867 - M Standard

0867 590354

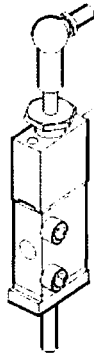
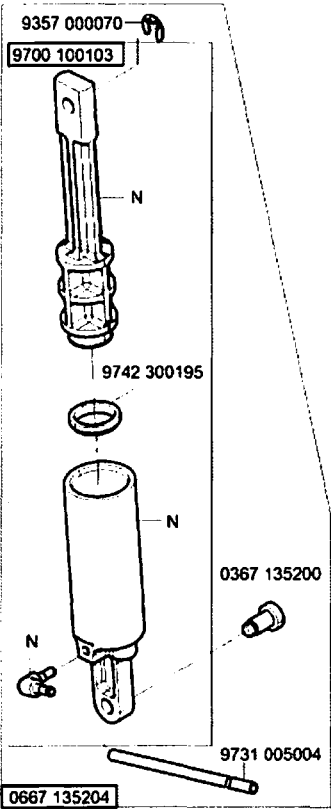

0667 135294

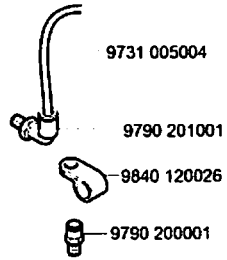

9840 121002 (2x)

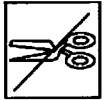
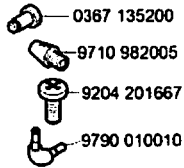

57

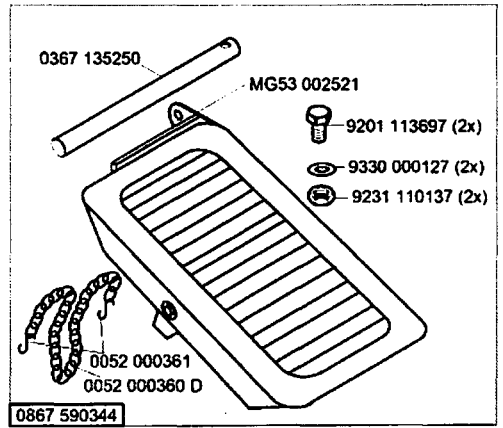

0867 590344

N - nicht als Einzelteil lieferbar
not available as separate part

Cl. 867 - M Standard

Ausgabe/Edition 1.2015

- CI.867 -160322-M
- CI.867 -190020-M
- CI.867 -190040-M
- CI.867 -190122-M
- CI.867 -190125-M
- CI.867 -190142-M
- CI.867 -190145-M
- CI.867 -190322-M
- CI.867 -190342-M
- CI.867 -190425-M
- CI.867 -190445-M

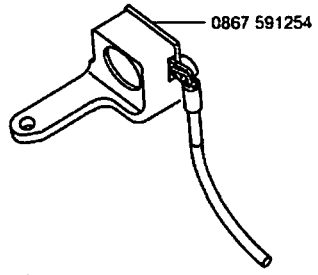

- 9840 120106 (2x)
- 9330 000087
- 9202 002077
- 9840 121001 (5x)

0867 591244 → 0867 591204
 → 0867 591214

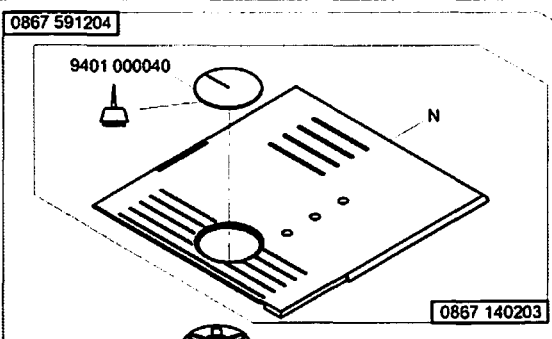

- 9401 000040
- 0867 150140
- 0867 150170
- CI.867 -160322-M
- CI.867 -190020-M
- CI.867 -190122-M
- CI.867 -190322-M

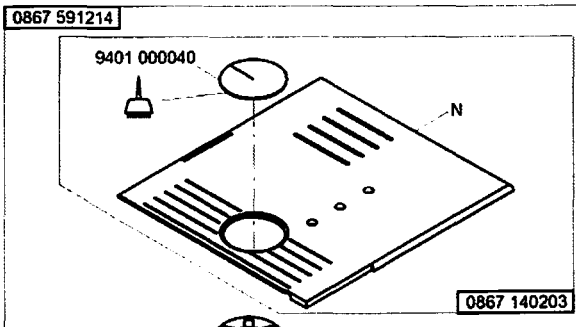

- 9401 000040
- 0867 150150
- 0867 150170
- CI.867 -190040-M
- CI.867 -190142-M
- CI.867 -190342-M

 -kleben -stick (mit Loctite Nr. 350/Materialnummer 9049 080016 eingeklebt
 UV - ausgehärtet
 glued Loctite No. 350/material number 9049 080016
 UV - cured)

N - nicht als Einzelteil lieferbar
 not available as separate part

CI. 867 - M Standard

0867 590684

9840 121001 (2x)



0791 867951



0867 110564

9850 H66703

0867 110570

H667 110050

9840 121001 (2x)



9330 700097
9204 201647



9081 500051

0791 000007

0993 904247

9081 200500

0667 295050

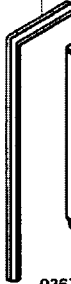

0367 105950

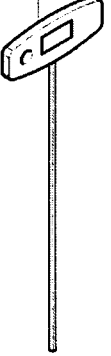
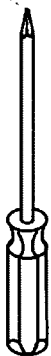

9081 300001

N - nicht als Einzelteil lieferbar
not available as separate part

0667 105164

0699 989250



0791 867710 EN

1001 009243

0867 490030

9330 000087

9204 201697

9204 201657

0867 590074

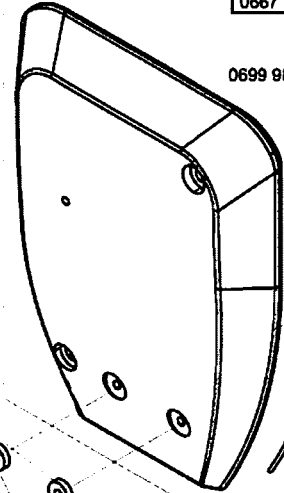

1001 009243

0867 490030

9330 000087

9204 201697

9204 201657

0867 590074

9840 121001 (3x)



9815 920034

9840 120025

9330 000087

9204 201067

CI. 867 - M Standard

9870 001301

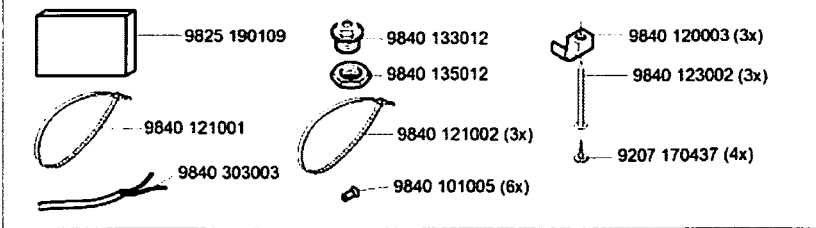

9835 901005

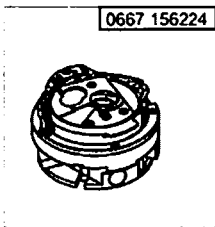
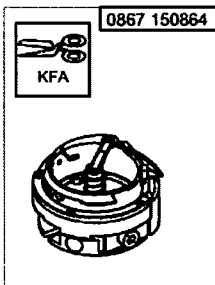

0867 590984

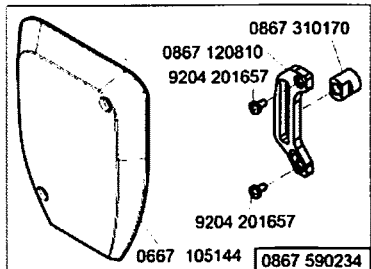
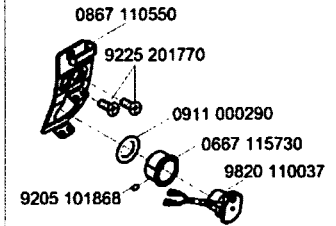

0667 595204 auf Wunsch on request

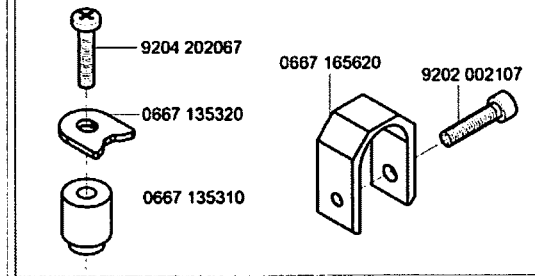
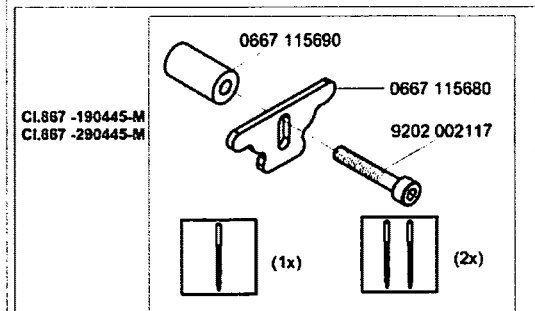

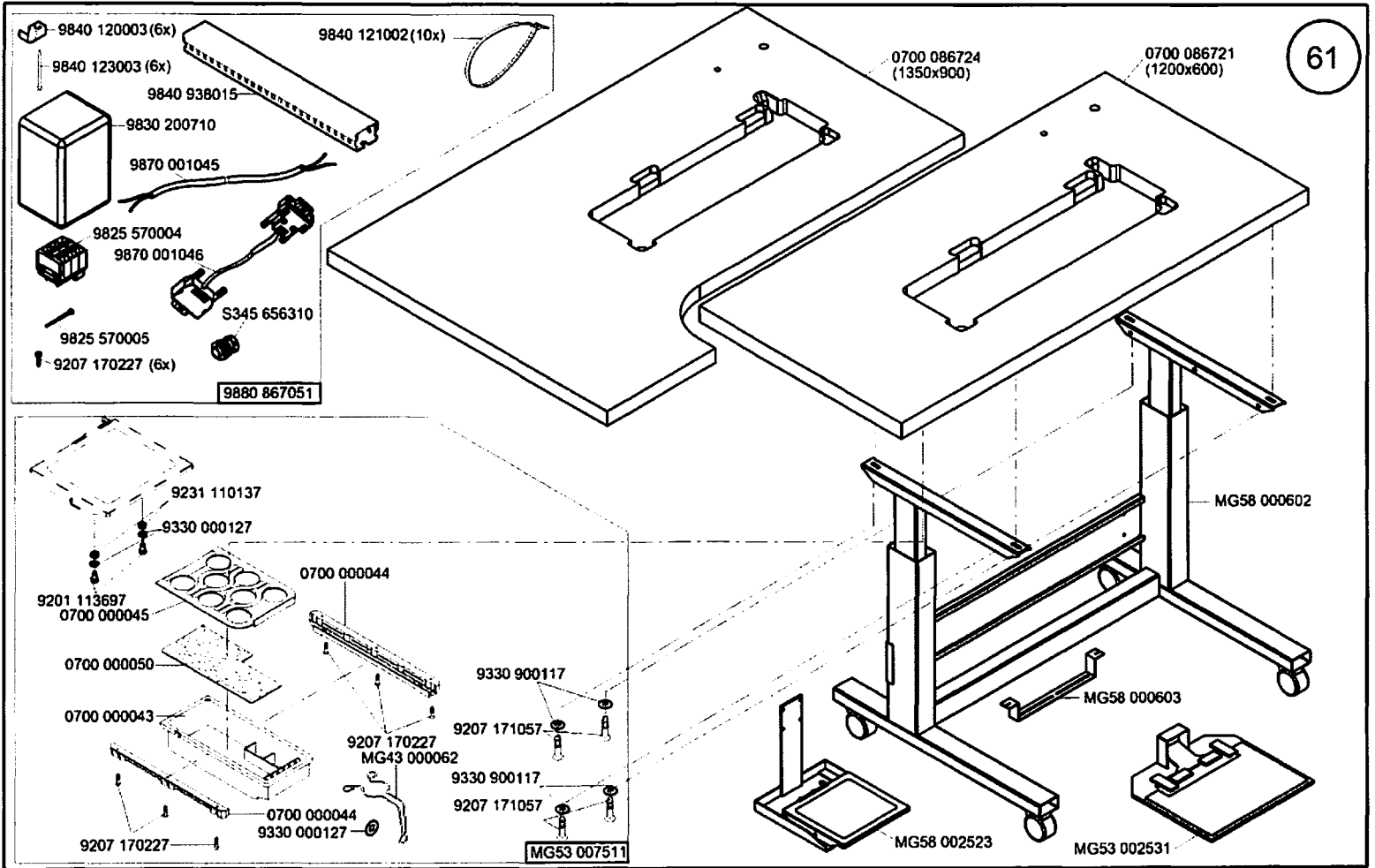

CI. 867 - M Standard

Ausgabe/Edition 10.2015

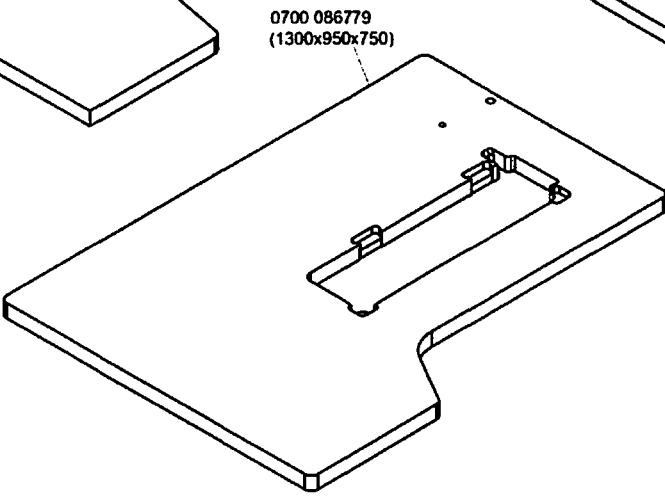
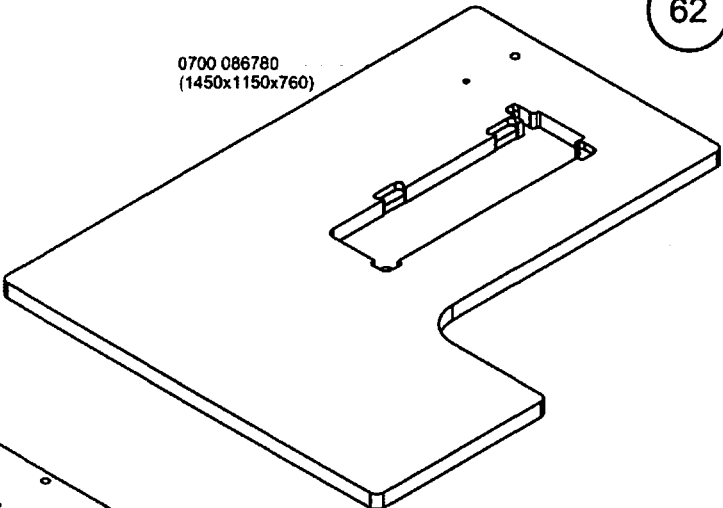
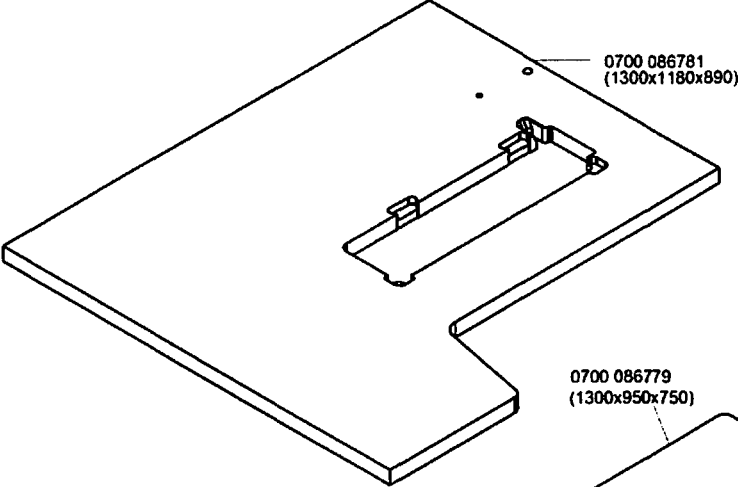

Cl. 867 - M Standard

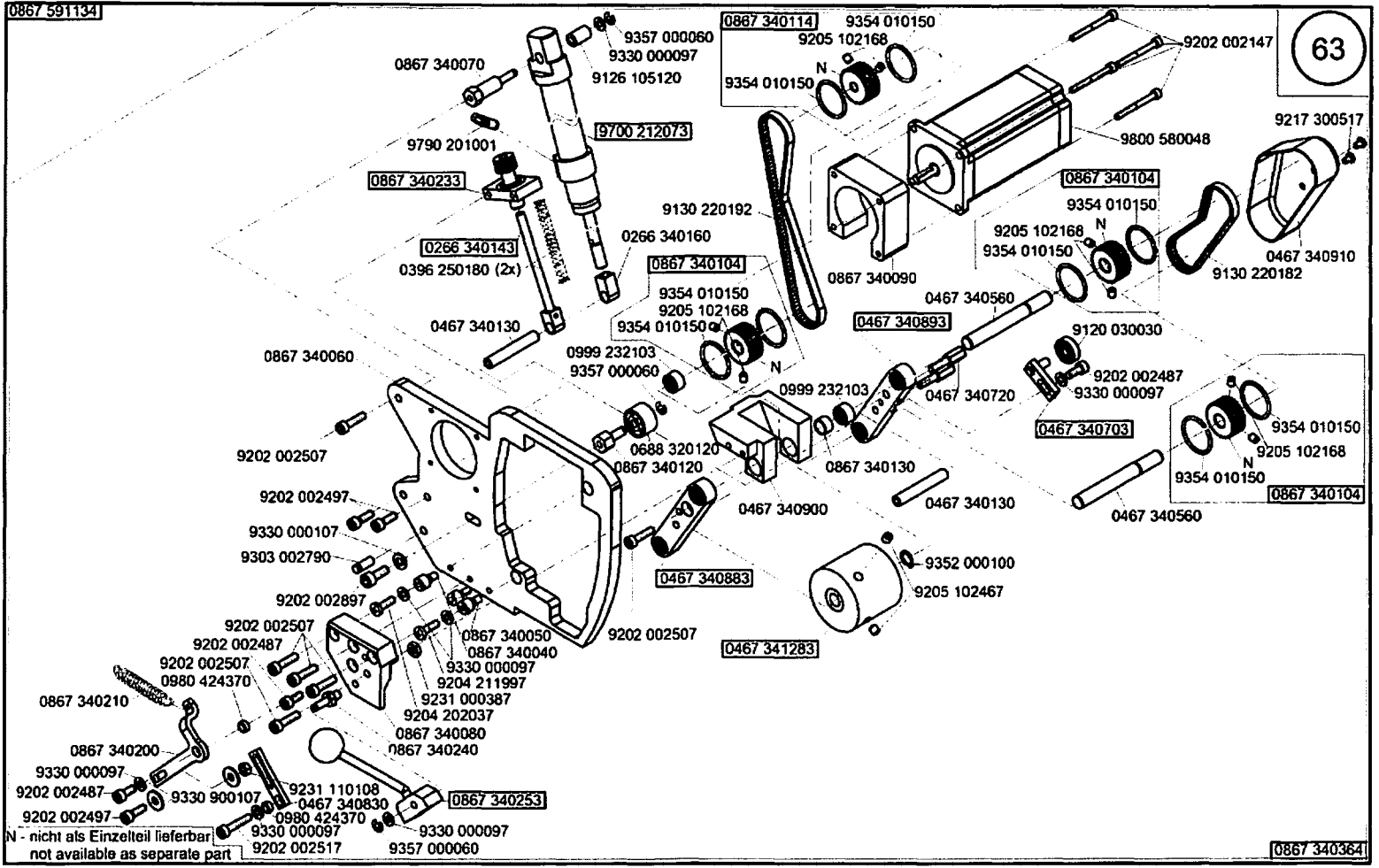

Cl. 867 - M Standard

Ausgabe/Edition 1.2016

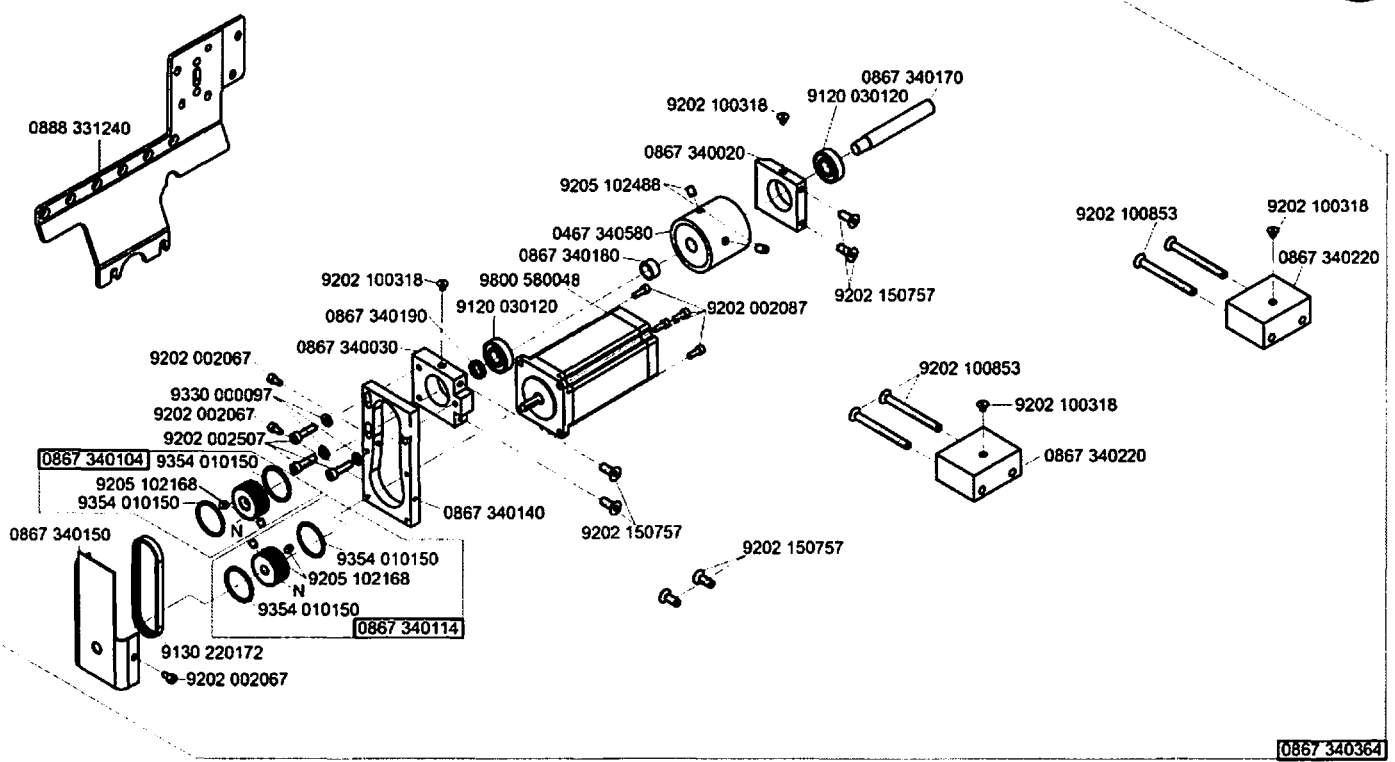

N - nicht als Einzelteil lieferbar
not available as separate part

Cl. 867 - M Standard

0867 591134

- 9330 000067 (2x)
- 9330 000087 (7x)
- 9330 900077 (2x)
- 9203 003207 (2x)
- 9231 110057 (3x)
- 9231 110037 (2x)

- 0702 000020 (2x)
- 9202 002067 (3x)
- 9202 002167 (4x)
- 9203 001917 (6x)
- 9231 000367 (4x)

- 9710 920012 (2x)
- 9710 982003 (3x)
- 9781 000006
- 9790 111001
- 9792 001030 (2x)
- 9790 200000
- 9790 201000 (4x)
- 9731 005004

- 0867 340270
- 0367 160750
- 0867 340260 (3x)
- 0744 001819
- 0999 240408

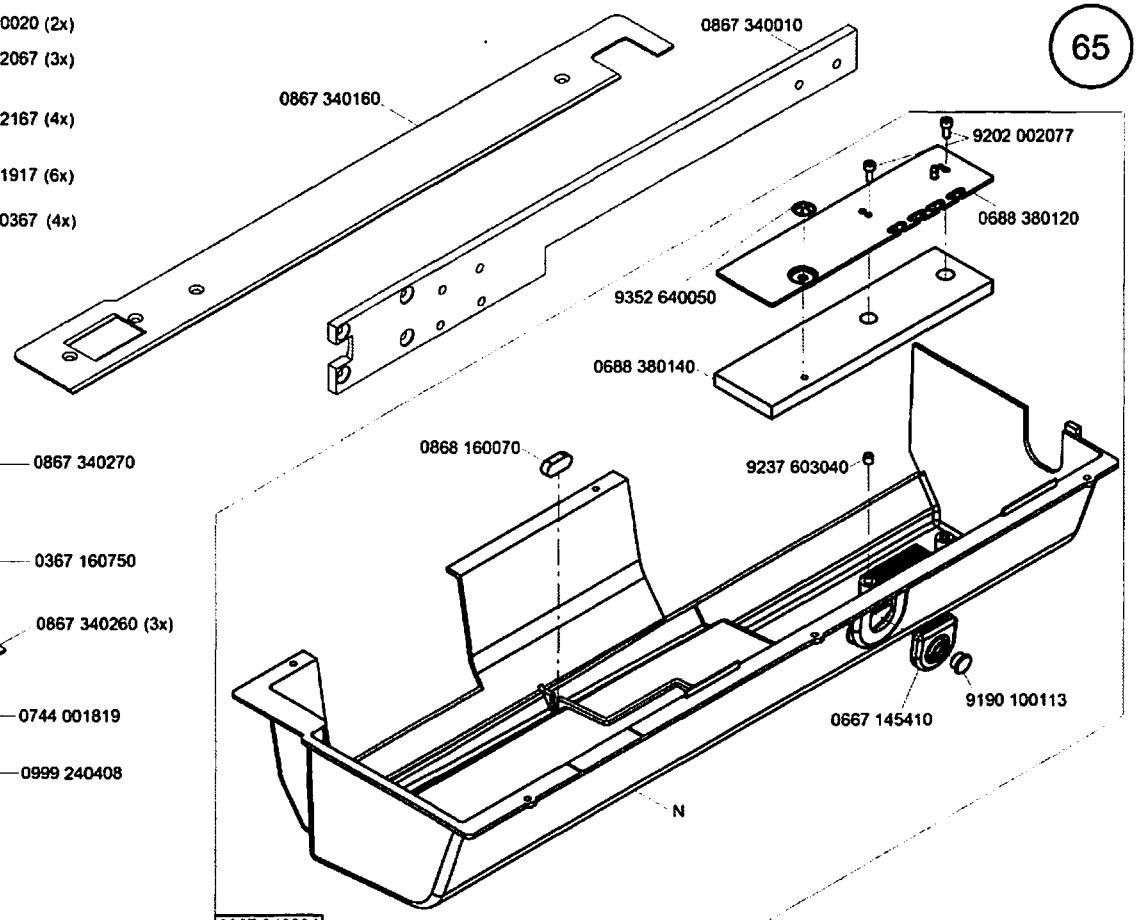

0867 340294

Cl. 867 - M Standard

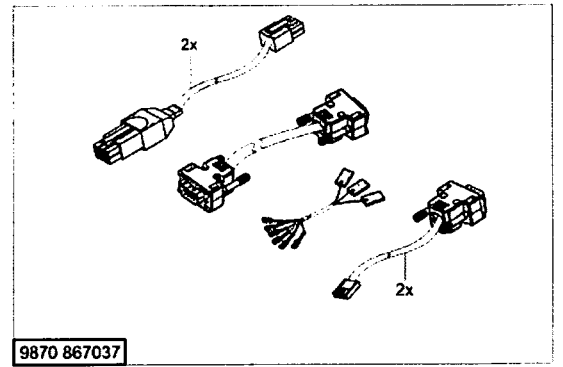
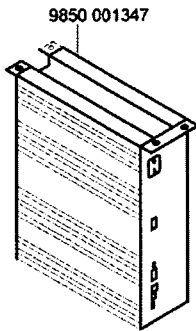
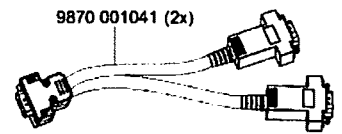
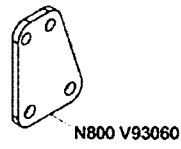
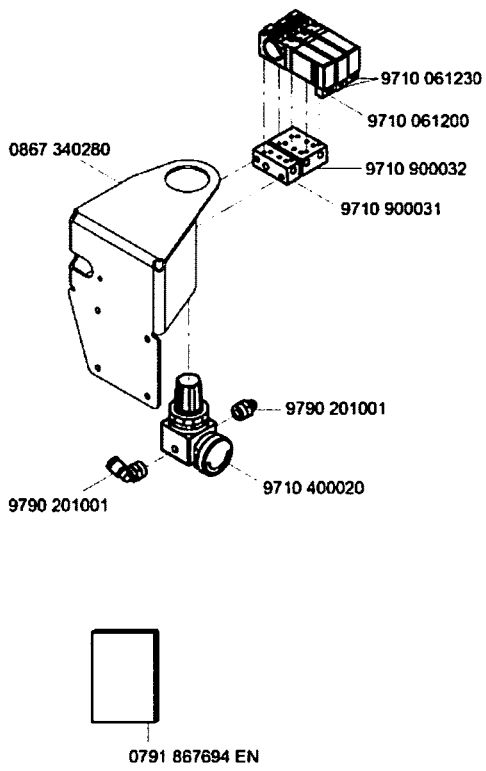

Cl. 867 - M Standard

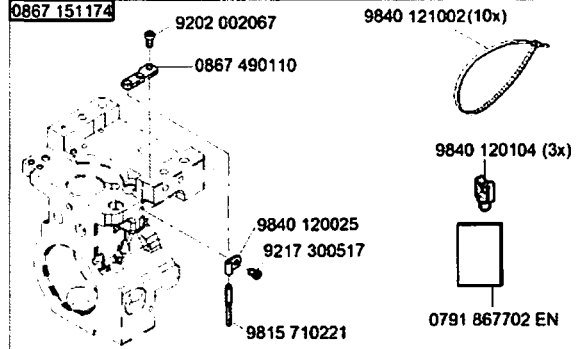
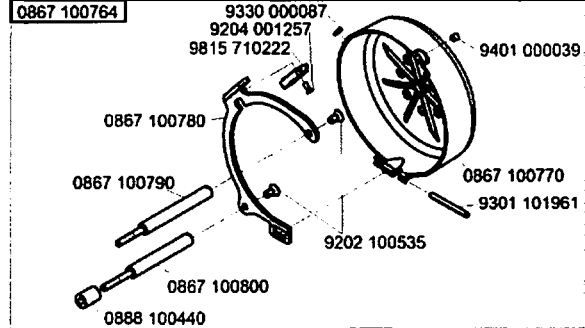
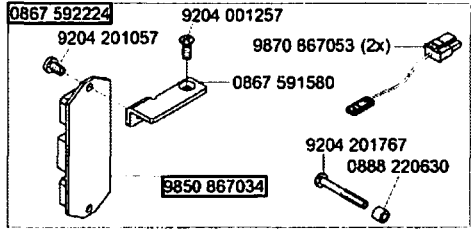
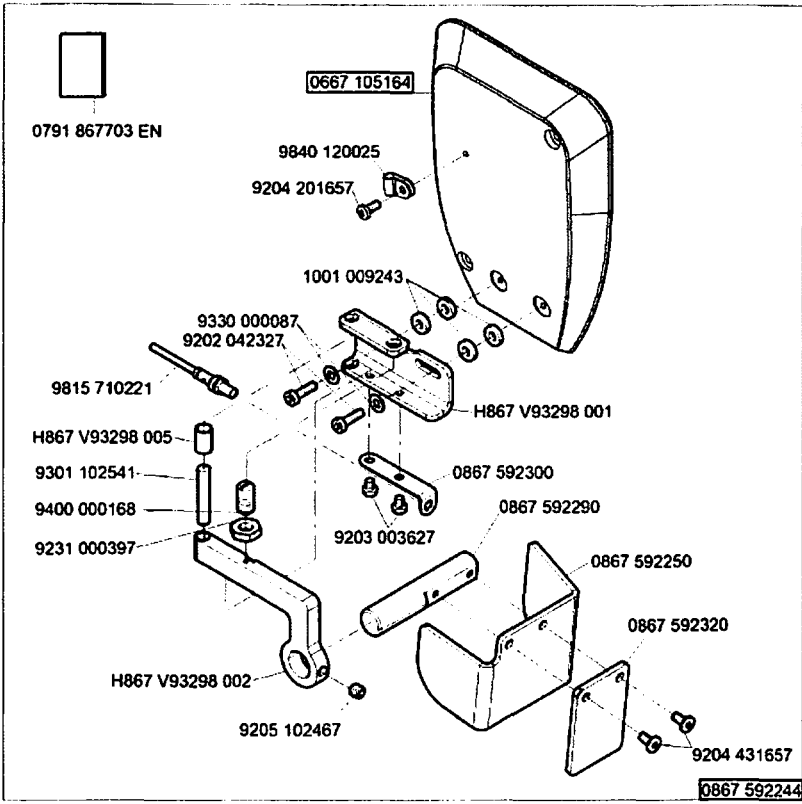

Cl. 867 - M Standard

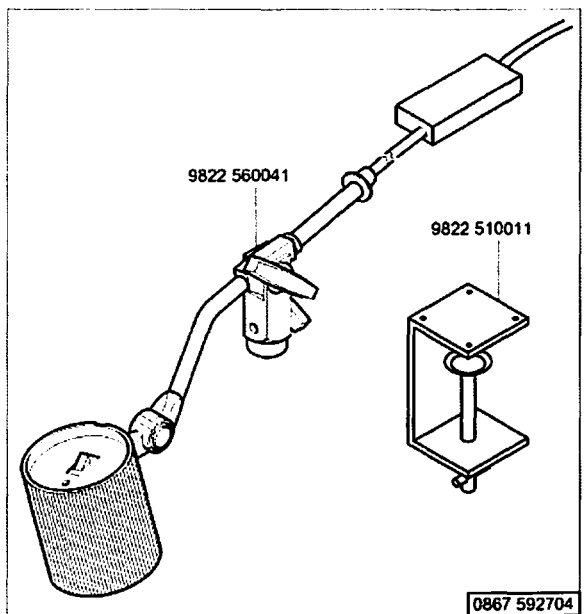
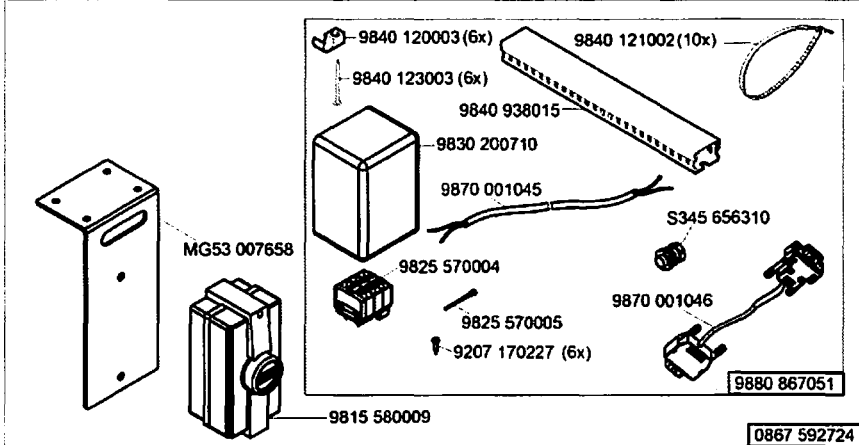
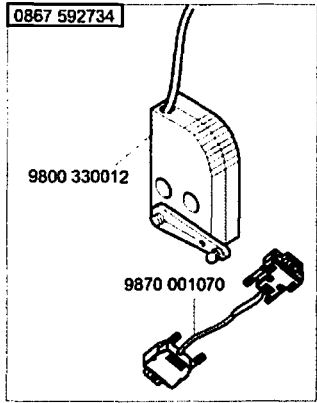
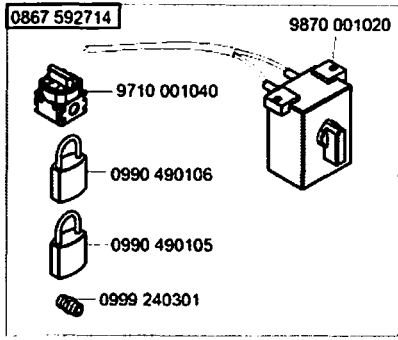

Cl. 867 - M Standard

0867 591184

CI.867 -190145-M
CI.867 -190445-M

69

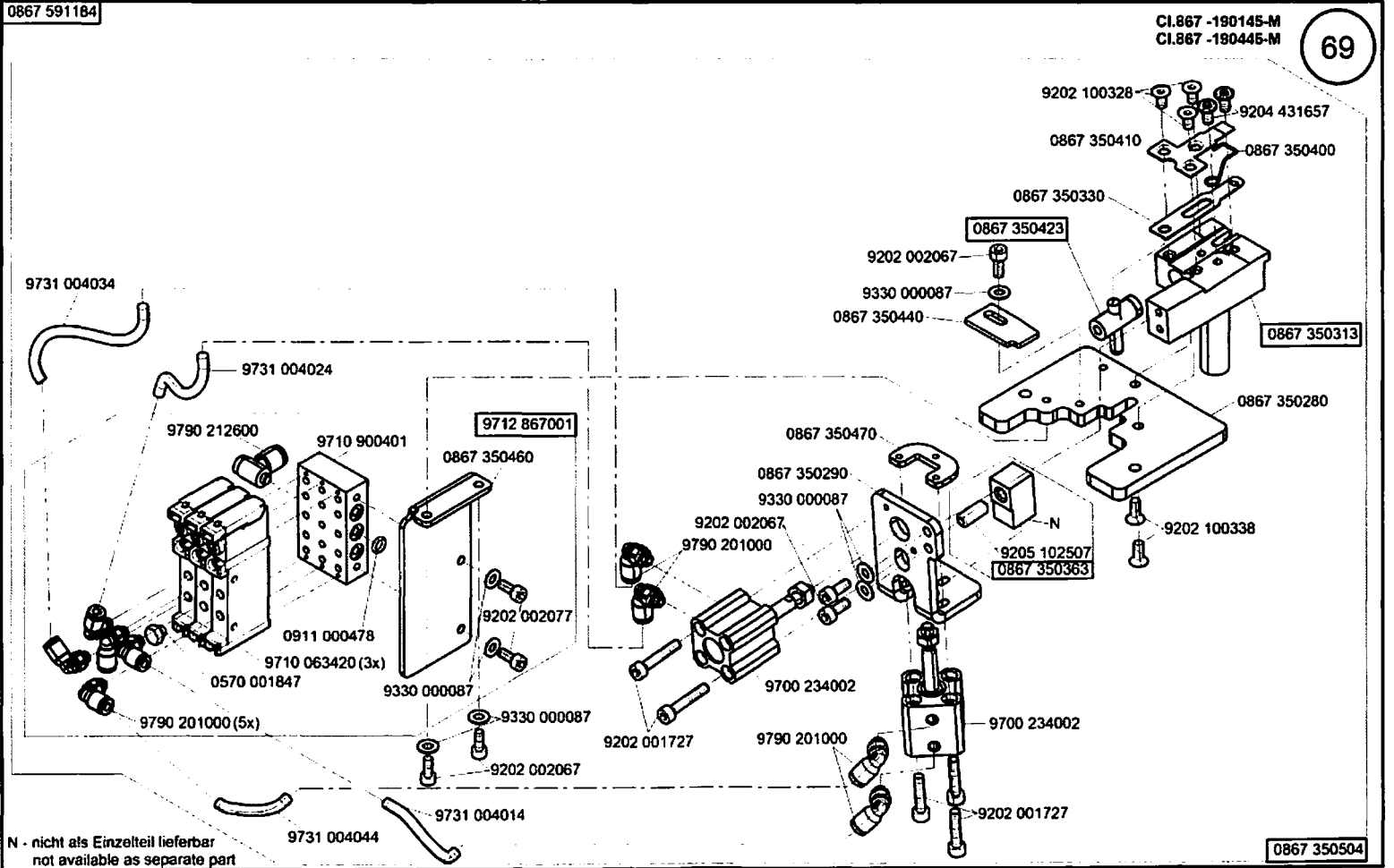

N - nicht als Einzelteil lieferbar
not available as separate part

CI. 867 - M Standard

Ausgabe/Edition 11.2018

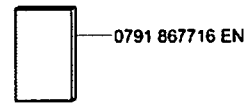
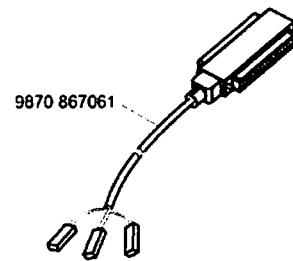
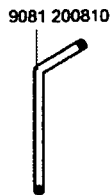
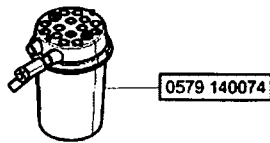
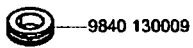
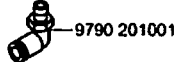
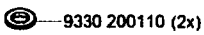
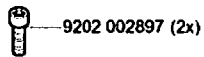
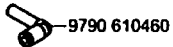
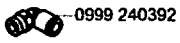
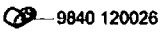
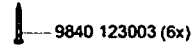
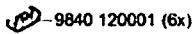
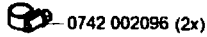
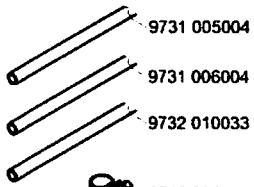

N - nicht als Einzelteil lieferbar
not available as separate part

Klasse/Class: 867 - M Standard	Index	Ausgabe/Edition: 11/2018
---------------------------------------	--------------	---------------------------------

Teile-Nr./Part-No.	Tafel/Table	Teile-Nr./Part-No.	Tafel/Table	Teile-Nr./Part-No.	Tafel/Table	Teile-Nr./Part-No.	Tafel/Table	Teile-Nr./Part-No.	Tafel/Table
0002 002037 0400	39	0291 000347	39	0467 110220	25,26,27,28,29,30	0667 105190	40	0667 115430	25,28
0037 001280	25,26,27,28,29,30	0291 000537	38			0667 105254	40	0667 115440	26,27
		0291 000538	38	0467 150040	13,14,19	0667 105284	42	0667 115444	26
0052 000360 D	57	0367 105083	6,7,8	0467 150120	13,14,15,19	0667 110340	39	0667 115490	25,27
0052 000361	57	0367 105180	6,7,8	0467 150130	13,14,15	0667 115070	25,28	0667 115514	25
0053 000350	25,28	0367 105910	44	0467 150440	14,15,16,17,18,19	0667 115080	25,28	0667 115520	25,26,27,28,29,30
0061 001050	25,26,27,28,29,30	0367 105950	59	0467 340130	63	0667 115090	25,28		
		0367 110340	25,26,27,28,29,30	0467 340560	63	0667 115094	28	0667 115530	25,26,27,28,29,30
0077 110230	50			0467 340580	64	0667 115110	28,30		
0099 004800	51	0367 110360	25,26,27,28,29,30	0467 340703	63	0667 115120	25,27,28,30	0667 115570	28,29,30
0099 004910	25,26,27,28,29,30			0467 340720	63	0667 115130	25,28	0667 115580	28,29,30
		0367 120100	3,4	0467 340830	63	0667 115134	25,28	0667 115590	25,26,27,28,29,30
0104 250010	50	0367 125020	6	0467 340883	63	0667 115140	25,28	0667 115600	25,26,27
0167 241433	54	0367 125194	3	0467 340893	63	0667 115150	25,28	0667 115610	25,26,27,28,29,30
0211 000648	20,21	0367 135200	11,57	0467 340900	63	0667 115160	25,28		
0211 000699	50	0367 135250	57	0467 340910	63	0667 115170	25,26,27,28,29,30	0667 115620	25,26,27
0216 000591	24	0367 140050	43	0467 341283	63			0667 115630	25,26,27,28,29,30
0219 000321	39,42	0367 145110	9	0480 350200	22	0667 115180	25,26,27,30		
0223 000454	51	0367 145180	6,7,8	0480 350214	22	0667 115203	26,27,29,30	0667 115640	25,26,27,28,29,30
0223 000481	51	0367 150860	38	0491 030652	7,33	0667 115210	26,27,29,30		
0223 000483	51	0367 160750	65	0556 000821 A	31,32	0667 115220	29,30	0667 115680	33,60
0244 000403	24	0367 165120	6,7	0570 000572	56	0667 115224	29	0667 115690	33,60
0244 000700	6,7,8,9	0367 165140	7	0570 001847	34,35,36,37,69	0667 115250	25,26,27,28,29,30	0667 115730	39,60
0245 001660 A	14	0367 165970	12,33	0579 140074	70			0667 125033	3
0265 000911	25,28	0367 315014	6	0667 100050	3,4	0667 115280	39	0667 125060	5
0266 340143	63	0367 315024	6	0667 105023	40,41,42	0667 115290	25,26,27,28,29,30	0667 125100	3,4
0266 340160	63	0367 315130	6	0667 105024	41			0667 125143	3
0271 000275	24	0367 315223	6,7,8,9	0667 105053	1	0667 115320	3,4	0667 125160	3,4
0271 001639	31,32	0367 385133	3,4	0667 105060	39	0667 115354	26,27,29,30	0667 125243	3,4
0281 380114	50	0367 495010	39	0667 105120	39	0667 115360	25,28	0667 125254	3,4
0291 000159	3,4	0396 111320	50	0667 105144	39,60	0667 115390	51	0667 135013	9
0291 000334	31,32	0396 250180	63	0667 105164	55,59,67	0667 115420	25,28	0667 135033	9

Teile-Nr./Part-No.	Tafel/Table	Teile-Nr./Part-No.	Tafel/Table	Teile-Nr./Part-No.	Tafel/Table	Teile-Nr./Part-No.	Tafel/Table	Teile-Nr./Part-No.	Tafel/Table
0667 135040	10	0667 155450	21	0667 160374	31,32	0667 170120	24	0667 355103	22
0667 135073	10	0667 155460	20,21	0667 165063	7	0667 175030	24	0667 355110	22
0667 135094	9	0667 155474	20	0667 165130	6	0667 175034	24	0667 355123	22
0667 135103	9	0667 155484	21	0667 165133	7	0667 175040	24	0667 355130	22
0667 135124	9	0667 155490	20,21	0667 165134	7	0667 175060	24	0667 355140	22
0667 135150	10	0667 155530	20,21	0667 165154	7	0667 235010	3	0667 355150	23
0667 135190	6	0667 155540	20,21	0667 165164	7	0667 245003	54	0667 355173	22
0667 135204	11,57	0667 155550	20,21	0667 165190	33	0667 245004	54	0667 355240	34,35,36,37
0667 135294	57	0667 155594	14	0667 165210	33	0667 245010	54	0667 355260	23
0667 135300	6	0667 155604	14	0667 165220	33	0667 295050	59	0667 355270	23
0667 135310	33,60	0667 155614	16	0667 165234	31,32	0667 310563	6	0667 355283	23
0667 135320	33,60	0667 155634	16	0667 165243	31,32	0667 315053	6	0667 355300	23
0667 145044	2	0667 155720	21	0667 165250	31,32	0667 315113	6	0667 355310	23
0667 145074	2	0667 155820	52	0667 165260	31,32	0667 315164	6	0667 355324	23
0667 145264	2	0667 155824	52	0667 165273	31,32	0667 315174	12	0667 355343	23
0667 145303	2	0667 155830	52	0667 165284	31,32	0667 315203	5	0667 355344	23
0667 145323	51	0667 155840	52	0667 165290	31,32	0667 315213	5	0667 355363	23
0667 145354	51	0667 155893	20,21	0667 165304	31,32	0667 315223	5	0667 355410	23
0667 145390	43	0667 155900	20,21	0667 165354	32	0667 315243	5	0667 355420	22,23
0667 145400	51	0667 155930	52	0667 165370	7	0667 315253	5	0667 385013	6,7
0667 145410	51,65	0667 155940	2	0667 165390	8	0667 315273	6	0667 385033	38
0667 145464	2	0667 155950	20	0667 165403	8	0667 315280	6	0667 385070	39
0667 150830	16	0667 156130	19	0667 165423	8	0667 315294	6	0667 385143	38
0667 150840	16,18	0667 156180	16,17,18	0667 165454	8	0667 315300	40,41,42	0667 385174	38
0667 150850	16,17,18,19	0667 156190	13,14,15,19	0667 165454	8	0667 315314	6	0667 385180	39
0667 150870	16,17	0667 156210	16,18	0667 165500	7	0667 315320	6	0667 385220	38
0667 155100	20,21	0667 156224	60	0667 165550	7	0667 315330	6	0667 495093	34,35,36,37
0667 155114	20	0667 156320	13,14,15	0667 165560	51	0667 315330	6	0667 495104	31,32
0667 155390	20,21	0667 156330	16,17,18,19	0667 165570	33	0667 315354	41	0667 495110	31,32
0667 155403	20,21	0667 156440	16,17,18	0667 165580	7	0667 315364	40,41	0667 495133	34,35,36,37
0667 155424	20,21	0667 160170	31,32	0667 165620	33,60	0667 315433	53	0667 495290	34,35,36,37
0667 155440	20	0667 160350	31,32	0667 165674	33	0667 315454	42	0667 495350	56
				0667 165700	33	0667 315464	42,60		

Teile-Nr./Part-No.	Tafel/Table	Teile-Nr./Part-No.	Tafel/Table	Teile-Nr./Part-No.	Tafel/Table	Teile-Nr./Part-No.	Tafel/Table	Teile-Nr./Part-No.	Tafel/Table
0667 595050	55	0744 001155	26,27,29,30	0867 100143	47	0867 120654	4	0867 160410	8
0667 595204	60	0744 001793 A	49	0867 100230	46,47	0867 120660	4	0867 160430	8
0688 100173	1	0744 001793 B	49	0867 100240	1	0867 120810	3,4,60	0867 160620	6,7
0688 130260	10	0744 001796	49	0867 100424	39	0867 120814	3,4	0867 160630	6,7
0688 130280	9	0744 001819	65	0867 100523	42	0867 140030	43	0867 160640	6
0688 130290	9	0744 050299	46,47	0867 100524	42	0867 140203	58	0867 170174	24
0688 130363	51	0767 150590	14,15,16,17	0867 100764	67	0867 140270	46,47	0867 170184	24
0688 130384	51	0791 000007	59	0867 100770	67	0867 140670	43	0867 172050	24
0688 320120	63	0791 001081	50	0867 100780	67	0867 150140	13,19,58	0867 172060	24
0688 380040	38	0791 001094	50	0867 100790	67	0867 150150	18,58	0867 172083	24
0688 380120	51,65	0791 001096	50	0867 100800	67	0867 150170	13,18,19,52,58	0867 172103	24
0688 380130	38	0791 580100	50	0867 103043	45	0867 150240	52	0867 172110	24
0688 380140	51,65	0791 867300	46	0867 103080	45	0867 150280	23	0867 172120	24
0699 979104	20,21,38	0791 867301	47	0867 103090	45	0867 150290	16,17,18	0867 210060	53
0699 979265	52,53	0791 867694 EN	66	0867 103100	45	0867 150323	20	0867 210100	53
0699 989250	39,40,41,42,55,59	0791 867702 EN	67	0867 103120	45	0867 150333	21	0867 310073	6
0700 000043	48,61	0791 867703 EN	67	0867 103130	45	0867 150343	20,21	0867 310170	3,4,60
0700 000044	48,61	0791 867704 EN	60	0867 103170	45	0867 150560	52	0867 310233	6
0700 000045	48,61	0791 867710 EN	59	0867 103193	45	0867 150754	18	0867 310430	6
0700 000050	48,61	0791 867715 EN	53	0867 103203	45	0867 150764	18	0867 310440	6
0700 000090	50	0791 867716 EN	70	0867 103220	46	0867 150804	13	0867 340010	65
0700 000091	50	0791 867720 EN	52	0867 110034	27	0867 150814	13	0867 340020	64
0700 086716	48	0791 867721 EN	55	0867 110064	30	0867 150864	60	0867 340030	64
0700 086717	48	0791 867951	59	0867 110250	25,26,27	0867 150904	19	0867 340040	63
0700 086721	61	0797 003031	49	0867 110260	28,29,30	0867 150914	19	0867 340050	63
0700 086722	48	0798 000677	45	0867 110280	25,28	0867 150930	52	0867 340060	63
0700 086724	61	0798 120213	56	0867 110340	25,28	0867 151050	13,14,15,19	0867 340070	63
0700 086779	62	0798 120401	53,56	0867 110364	27	0867 151174	67	0867 340080	63
0700 086780	62	0798 447914	44,54,56	0867 110384	30	0867 160024	31	0867 340090	63
0700 086781	62	0818 160210	7	0867 110550	39,60	0867 160203	8	0867 340104	63,64
0702 000020	65	0867 100120	46,47	0867 110564	59	0867 160274	6,7	0867 340114	63,64
0742 002096	49,70	0867 100133	46	0867 110570	59	0867 160404	8	0867 340120	63

Teile-Nr./Part-No.	Tafel/Table	Teile-Nr./Part-No.	Tafel/Table	Teile-Nr./Part-No.	Tafel/Table	Teile-Nr./Part-No.	Tafel/Table	Teile-Nr./Part-No.	Tafel/Table
0867 340130	63	0867 490010	47	0867 592300	67	0933 001544	38	9041 100203	38,50
0867 340140	64	0867 490024	39,54	0867 592320	67	0980 424370	63	9081 200253	50
0867 340150	64	0867 490030	59	0867 592704	68	0990 490105	68	9081 200303	50
0867 340160	65	0867 490110	67	0867 592714	68	0990 490106	68	9081 200500	59
0867 340170	64	0867 490250	39	0867 592724	68	0992 016580	13,14,15,16,17, 18,19	9081 200810	70
0867 340180	64	0867 490390	46,47	0867 592734	68	0992 023560	13,14,15,16,17, 18,19	9081 300001	59
0867 340190	64	0867 490400	34,35,36,37	0868 110054	28,29,30	0992 023577	13,14,15,16,17, 18,19	9081 500000	50
0867 340200	63	0867 590014	53	0868 120113	4			9081 500010	50
0867 340210	63	0867 590024	53	0868 140060	43	0993 904247	59	9081 500051	59
0867 340220	64	0867 590054	53	0868 150400	15	0995 340617	50	9120 030030	63
0867 340233	63	0867 590074	59	0868 150414	15	0998 881010	20,21	9120 030120	64
0867 340240	63	0867 590104	52	0868 150434	15	0998 881610	6,33	9122 200161	1
0867 340253	63	0867 590114	52	0868 150450	17	0998 882080	13,14,15,16,17, 18,19	9122 322200	5
0867 340260	65	0867 590124	52	0868 150464	17			9126 102520	6,7,31,32
0867 340270	65	0867 590134	52	0868 150484	17	0998 882510	25,27,28,30	9126 102540	6,7,31,32
0867 340280	66	0867 590234	60	0868 150520	17	0999 201114	43	9126 105120	63
0867 340294	65	0867 590344	57	0868 160070	51,65	0999 220752	38	9126 300061	20,21
0867 340364	63,64	0867 590354	57	0868 310080	6	0999 220848	55	9126 300088	20,21
0867 350083	23	0867 590464	33	0868 310084	6	0999 232103	63	9126 300201	5
0867 350280	69	0867 590684	59	0868 310090	6	0999 240301	68	9129 024235	3,4
0867 350290	69	0867 590984	60	0887 380010	38	0999 240376	21	9130 220172	64
0867 350313	69	0867 591134	63,64,65,66	0888 100440	67	0999 240389	52,53	9130 220182	63
0867 350330	69	0867 591184	69,70	0888 220630	67	0999 240392	70	9130 220192	63
0867 350363	69	0867 591204	58	0888 331240	64	0999 240394	53	9130 221130	2
0867 350400	69	0867 591214	58	0888 350124	22	0999 240402	70	9190 100108	39
0867 350410	69	0867 591244	58	0888 350134	22	0999 240408	36,37,65	9190 100113	51,65
0867 350423	69	0867 591254	58	0894 450378	45	1001 001162	39	9190 100155	40,41,42
0867 350440	69	0867 591580	67	0902 000423	43	1001 009243	55,59,67	9190 100226	20,21
0867 350450	70	0867 592224	67	0911 000290	39,60	9041 100025	3,4	9190 400120	31
0867 350460	69	0867 592244	67	0911 000339	55	9041 100030	20,21	9199 000004	34,35,37
0867 350470	69	0867 592250	67	0911 000478	34,35,37,52,53,69	9041 100035	38	9201 113677	51
0867 350504	69	0867 592290	67	0913 000731	50			9201 113697	48,57,61

Teile-Nr./Part-No.	Tafel/Table	Teile-Nr./Part-No.	Tafel/Table	Teile-Nr./Part-No.	Tafel/Table	Teile-Nr./Part-No.	Tafel/Table	Teile-Nr./Part-No.	Tafel/Table
9202 001667	55	9202 022497	22	9204 201037	45	9205 102450	20	9231 110127	55
9202 001678	3,4,24	9202 042067	8	9204 201057	67	9205 102464	31,32	9231 110137	48,57,61
9202 001727	69	9202 042327	67	9204 201067	24,31,32,34,35, 36,37,59	9205 102467	1,2,5,6,7,8,9,12, 20,21,22,23,24, 59,63	9234 000067	31,32
9202 002057	6,7,20,21,23,33	9202 100318	64	9204 201647	25,26,27,28, 29,30,31,32,39, 43,45,46,47,54,59	9205 102477	2,3,4,6,8,13,14, 15,16,17,18,19, 25,28,31,32	9237 603040	65
9202 002067	8,38,64,65,67,69	9202 100328	69					9301 101561	8,22
9202 002077	20,21,23,31,32, 39,44,51,52,54, 58,65,69	9202 100338	69	9204 201657	3,4,59,60,67			9301 101961	67
		9202 100535	13,14,15,16,17, 18,19,22,23,39, 43,67	9204 201667	3,4,24,33,34,35, 36,37,38,39,52,57	9205 102487	45	9301 102203	6
9202 002078	3,4			9204 201697	50,59	9205 102488	64	9301 102541	67
9202 002087	32,33,38,39, 51,64	9202 100853	64	9204 201767	67	9205 102507	69	9301 200660	20,21
		9202 150757	64	9204 201827	25,27,28,30	9205 102513	31,32	9302 000100	38
9202 002097	23,31,32,44	9203 001867	31,32	9204 201977	45	9205 102778	55	9303 002790	63
9202 002098	5,7,8,9,22,23, 31,32	9203 001917	65	9204 202037	56,63	9205 121558	20,21	9305 100350	25,26,27
		9203 002437	45	9204 202067	33,56,60	9205 122488	20,21	9305 100370	28,29,30
9202 002107	22,23,33,55,60	9203 002497	45	9204 202297	46,47	9206 100637	38,51	9330 000027	31,32
9202 002117	33,60	9203 003077	53	9204 211997	6,7,31,32,39,40, 41,42,45,47,51, 55,63	9206 100637	38,51	9330 000047	45
9202 002147	63	9203 003087	34,35,36,37	9204 212057	39,55	9207 161237	50	9330 000067	25,26,27,28, 29,30,34,35,36, 37,65
9202 002167	65	9203 003097	52,53	9204 301467	34,35,36,37	9207 170227	45,48,56,61,68		
9202 002487	63	9203 003157	52,53	9204 301487	24	9207 170437	39,44,47,54,60	9330 000087	3,4,5,7,8,23,25, 26,27,28,29,30, 31,32,51,54,55, 59,65,67,69
9202 002497	63	9203 003207	65	9204 302217	12,32,33	9207 170857	45		
9202 002507	63,64	9203 003627	67	9204 431657	26,27,29,30,67,69	9207 171057	48,61		
9202 002517	63	9203 100002	25,26,27,28, 29,30	9205 024857	20,21	9217 000157	55	9330 000088	20,21,58
9202 002877	54	9203 211837	13,14,15,16,17, 18,19	9205 101548	52	9217 300517	63,67	9330 000097	22,45,56,63,64
9202 002888	31,32	9203 312412	3,4	9205 101827	4	9225 201750	3,4	9330 000107	6,56,63
9202 002897	63,70	9203 312447	55	9205 101847	3,43	9225 201770	25,26,27,28, 29,30,39,44,60	9330 000127	10,48,57,61
9202 002908	20,21	9203 313047	53	9205 101868	39,60	9231 000367	23,65	9330 000177	50
9202 002917	10	9204 001257	45,67	9205 101958	23	9231 000387	9,23,63	9330 200107	22,23
9202 002918	6	9204 002363	43	9205 102168	63,64	9231 000397	67	9330 200110	20,21,70
9202 002927	9,49	9204 101657	6	9205 102303	6	9231 011137	51	9330 700097	59
9202 003027	45	9204 200447	34,37			9231 110037	24,34,35,36,37,65	9330 700107	40,41,42
9202 003738	39	9204 200517	34,35,36,37,52,53			9231 110057	65	9330 900077	65
9202 022467	38					9231 110108	63	9330 900093	51
9202 022477	22,23								

Teile-Nr./Part-No.	Tafel/Table	Teile-Nr./Part-No.	Tafel/Table	Teile-Nr./Part-No.	Tafel/Table	Teile-Nr./Part-No.	Tafel/Table	Teile-Nr./Part-No.	Tafel/Table
9330 900107	63	9700 100040	55	9731 005004	11,12,26,27,29, 30,32,33,34,35, 36,37,53,57,65,70	9815 301096	34,35	9840 120025	52,59,67
9330 900117	48,61	9700 100094	12			9815 310008	34,35,36,37	9840 120026	31,32,38,39,44, 54,56,57,70
9332 500137	25,27,28,30	9700 100100	32,33			9815 310009	34,35,36,37		
9333 000090	43,45	9700 100103	11,57	9731 006004	70	9815 580008	66	9840 120030	50
9334 000051	20,21	9700 212073	63	9731 007035	3,4	9815 580009	68	9840 120060	45,47
9334 001630	3,4,6,7,10,24, 31,32	9700 234002	69	9732 010033	70	9815 710221	67	9840 120104	22,23,34,35,36, 37,38,67
		9710 001040	68	9740 000607	40,41,42	9815 710222	67		
9334 001640	5,8	9710 061200	34,35,36,37,52, 53,66	9742 300190	12	9815 920024	59	9840 120105	33,38
9352 000100	63			9742 300195	11,57	9815 920034	59	9840 120106	52,58
9352 640050	51,65	9710 061230	66	9780 000108	49	9815 925002	52	9840 120155	47
9353 000087	20,21	9710 063420	69	9781 000006	65	9820 110016	23	9840 120156	47
9353 000350	2	9710 400020	66	9790 000220	53	9820 110037	39,60	9840 121001	39,44,45,50,53, 54,56,58,59,60
9353 000420	2	9710 900011	34,37	9790 010010	57	9820 110040	22	9840 121002	47,52,53,57,60, 61,67,68
9353 000470	1,2	9710 900031	52,53,66	9790 020010	29,30	9822 510011	68		
9354 010150	63,64	9710 900032	66	9790 030020	52	9822 560000	56	9840 123003	39,44,45,54,56, 60,61,68,70
9354 010210	2	9710 900047	34,35,37	9790 111001	65	9822 560021	44		
9354 400800	20,21,38	9710 900073	36	9790 200000	34,35,36,37,65	9822 560041	68	9840 130007	38
9357 000050	22,23	9710 900401	69	9790 200001	57	9825 190109	60	9840 130008	38
9357 000060	63	9710 920012	34,35,36,37,53,65	9790 201000	34,35,36,37,65,69	9825 551102	34,35,36,37	9840 130009	70
9357 000070	6,7,10,11,12,20, 21,24,31,32,57	9710 920013	55	9790 201001	51,57,63,66,70	9825 570004	61,68	9840 132015	44,56
		9710 982003	36,52,53,65	9790 212600	69	9825 570005	61,68	9840 133012	44,54,56,60
9357 000080	8,25,28	9710 982005	57	9790 315002	52	9830 200710	61,68	9840 133013	44,56
9357 000090	5,6,10	9710 982006	34,35,37	9790 610460	70	9830 501010	34,35,36,37,52	9840 135012	44,54,56,60
9357 000100	31,32	9712 867001	69	9792 001030	65	9830 502007	45	9840 303003	60
9357 000120	6,7,31,32	9731 001035	38	9800 210001 R	47	9830 502014	38	9840 938 015	61,68
9380 521220	51	9731 002001	49	9800 210003 R	46	9835 200236	47	9850 001083	54
9400 000090	43	9731 004014	69	9800 330012	68	9835 901005	60	9850 001089	54
9400 000168	67	9731 004024	69	9800 580048	63,64	9840 101005	60	9850 001311	47
9401 000039	67	9731 004034	69	9815 301079	34,35,36,37	9840 104001	44,56	9850 001330	46
9401 000040	58	9731 004044	69	9815 301081	34,35	9840 120001	45,70	9850 001340	47
9401 000194	46,47			9815 301090	34,35,36,37	9840 120003	39,44,47,54,56, 60,61,68	9850 001347	66
9401 000204	46,47			9815 301091	34,35,36,37			9850 001351	47

Teile-Nr./Part-No.	Tafel/Table	Teile-Nr./Part-No.	Tafel/Table	Teile-Nr./Part-No.	Tafel/Table	Teile-Nr./Part-No.	Tafel/Table	Teile-Nr./Part-No.	Tafel/Table
9850 867000	34,35,36,37	9880 867051	61,68	N800 005647	55				
9850 867001	38	9880 867100	44	N800 005650	55				
9850 867003	52	9880 867101	34,35	N800 005655	54				
9850 867010	45	9880 867102	39,54	N800 075013	54				
9850 867034	67	9880 867103	56	N800 080001	54				
9850 H66703	59	9880 867110	36,37	N800 080003	54				
9870 001020	68	9880 867119	12	N800 080004	54				
9870 001041	66	H667 110050	59	N800 080012	54				
9870 001045	61,68	H868 V93298 001	67	N800 080021	54				
9870 001046	61,68	H868 V93298 002	67	N800 080022	54				
9870 001070	68	H868 V93298 005	67	N800 V93060	66				
9870 001113	50	MG43 000062	48,61	S345 656310	61,68				
9870 001301	60	MG53 002501	48	Z100 011022	20,21				
9870 367003	52,53	MG53 002521	57	Z132 001452	53				
9870 867000	47	MG53 002531	61						
9870 867001	22,23	MG53 007511	48,61						
9870 867002	31,32	MG53 007658	68						
9870 867003	52	MG53 007921	49						
9870 867013	47	MG53 007922	49						
9870 867014	47	MG55 000501	48						
9870 867016	47	MG58 000602	61						
9870 867018	47	MG58 002603	61						
9870 867019	45	MG58 002523	61						
9870 867023	46	N800 005613	55						
9870 867037	66	N800 005614	55						
9870 867053	67	N800 005615	55						
9870 867061	70	N800 005641	55						
9880 001001	45	N800 005642	55						
9880 001005	47	N800 005643	55						
9880 002005	12	N800 005644	55						
9880 867031	46	N800 005645	55						
9880 867032	47	N800 005646	55						

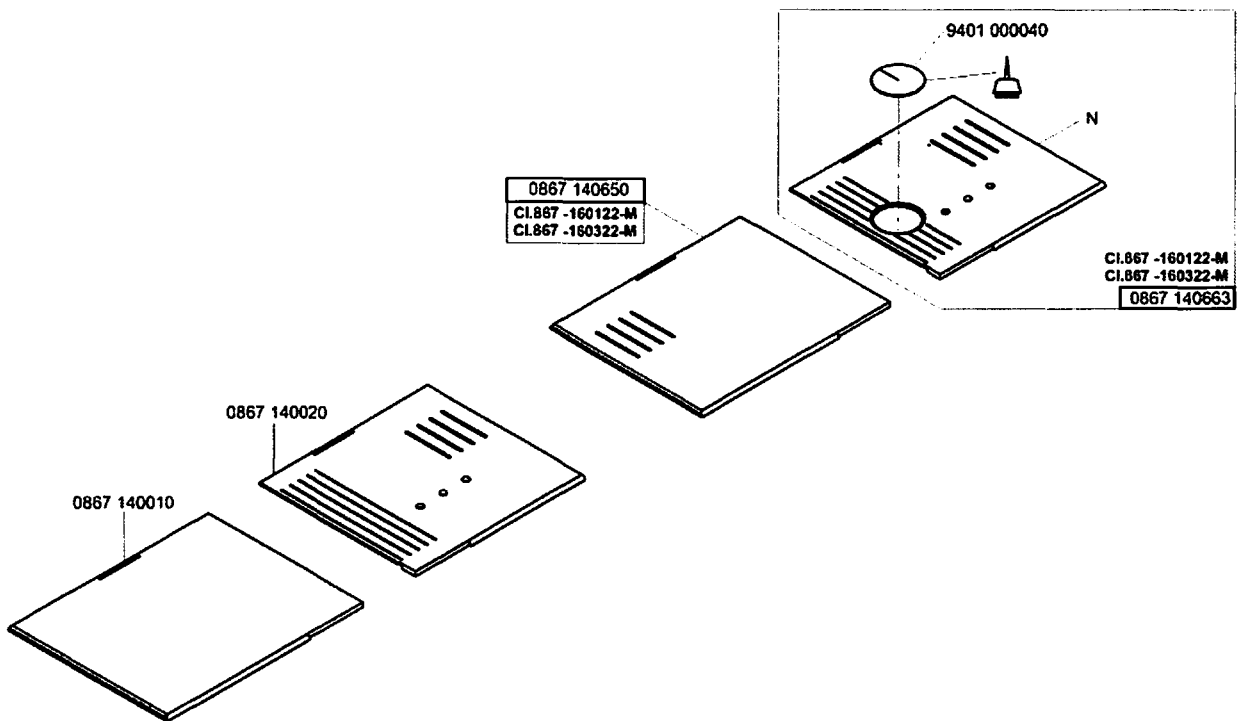

 -kleben -stick (mit Loctite Nr. 350/Materialnummer 9049 080016 eingeklebt
 UV - ausgehärtet
 glued Loctite No. 350/material number 9049 080016
 UV - cured)

N - nicht als Einzelteil lieferbar
 not available as separate part

Cl. 867 - M Standard

Ausgabe/Edition 10.2017

Befestigungsteile für Näheinrichtungen
Fastening parts for Sewing equipment

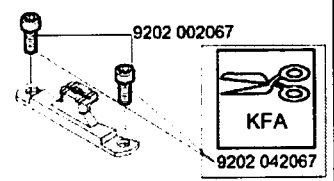
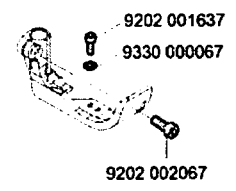
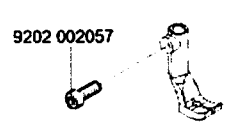
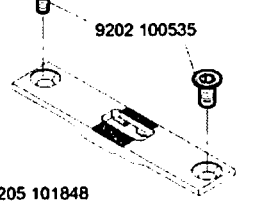
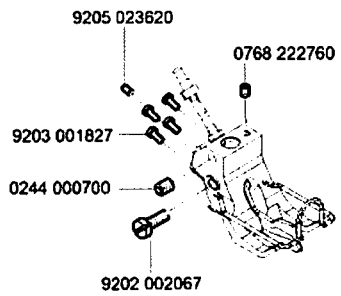
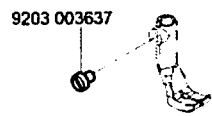
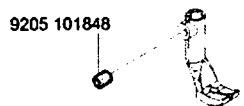
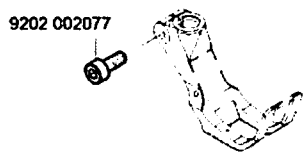
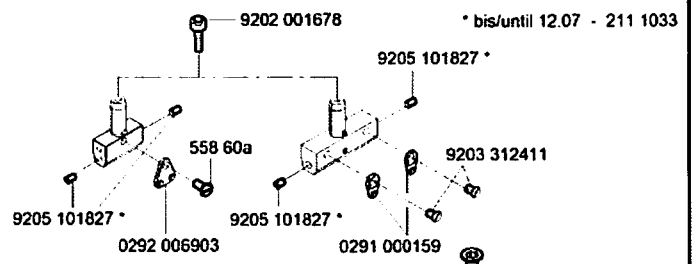
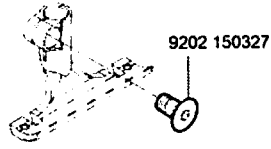

Cl. 867 - M Standard

Ausgabe/Edition 11.2018



Pneumatische Anschluss/Pneumatic connection

Die Näheinrichtungen: E24/6/9, E24/8/9, E24/10/9, E24/12/9, E24/8/12, E24/10/12, E24/12/12, E24/14/12, beinhalten auch die unten abgebildete Komponente.

The following sewing equipments: E24/6/9, E24/8/9, E24/10/9, E24/12/9, E24/8/12, E24/10/12, E24/12/12, E24/14/12, include also the below reproduced component.

0867 590064

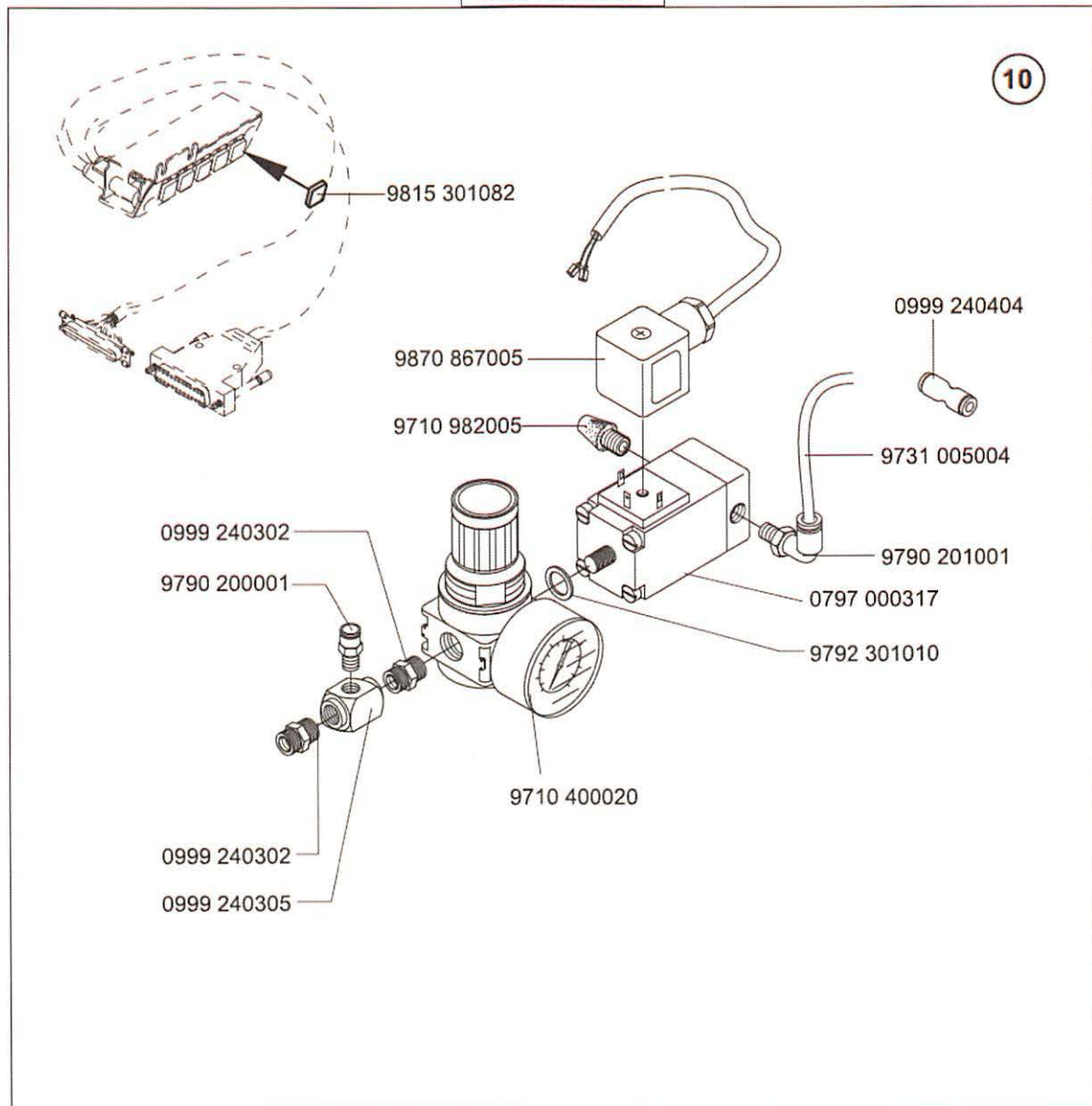

 = Änderung / Modification



Schieber mit Sichtfenster kann für folgende Näheinrichtungen bestellt werden /
Slide with window can be ordered for the following equipment:

Schieber, rechts /Slide, right

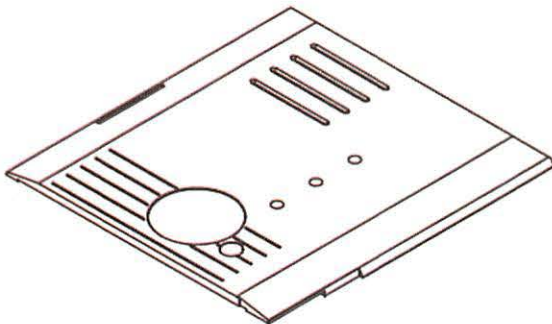

— **0867 140213** für/for 867 E101/0-6; 867 E102/0-9;
867 E104/0-9

— **0867 140423** für/for 867 E101-7; 867 E111/0-6;
867 E112/0-9; 867 E121/0-6; 867 E121/0-7;
867 E122/0-9

— **0867 140543** für/for 867 E121/8/7

— **0867 140783** für/for 867 E75/3,2/6; 867 E75/4,8/6;
867 E75/6,4/6

Schieber, links /Slide, left

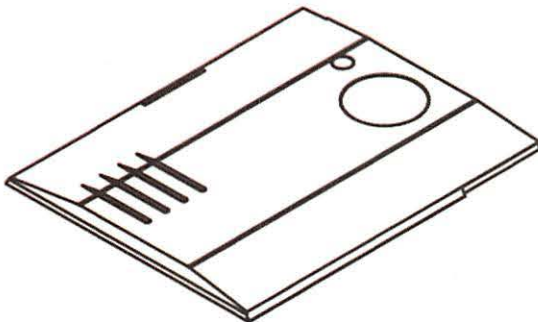

— **0867 140533** für/for 867 E121/8/7

— **0867 140743** für/for 867 E75/3,2/6; 867 E75/4,8/6;
867 E75/6,4/6

 = Änderung / Modification



E1

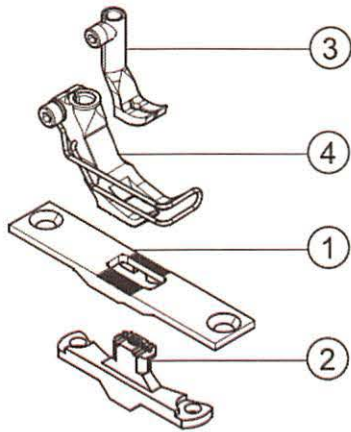

E2



E3

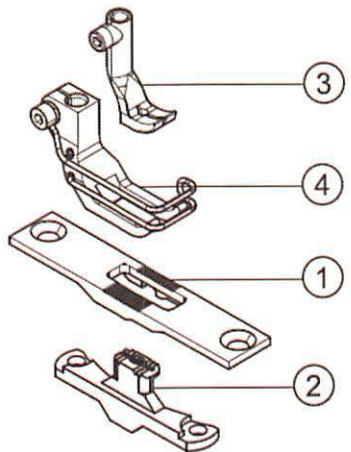

E4

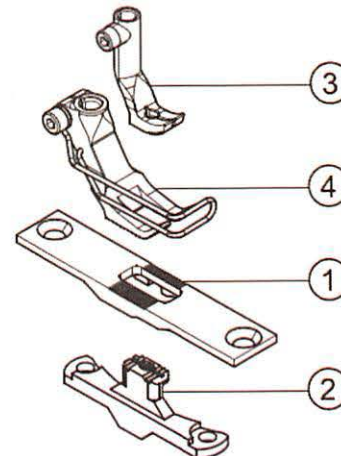

E5

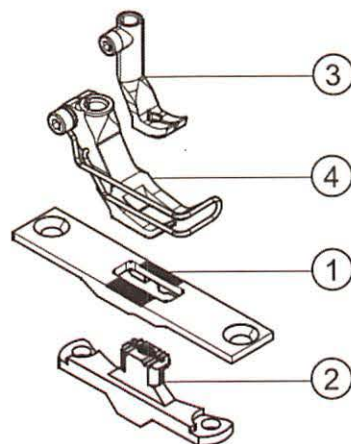

E6

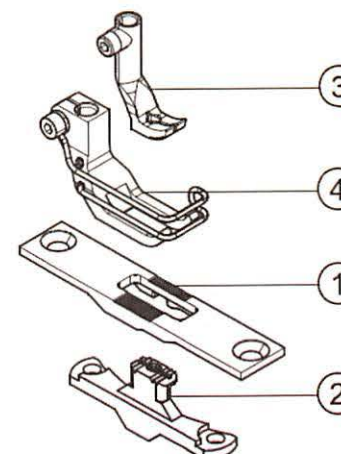

 = Änderung / Modification



E7

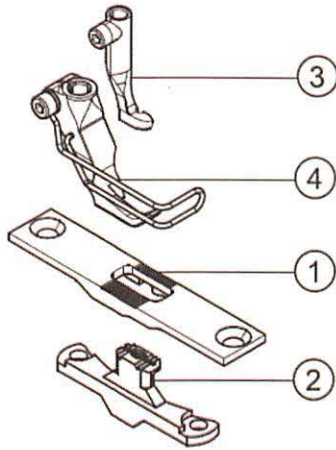

E8

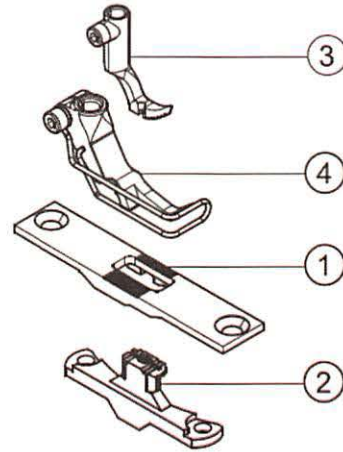

E11

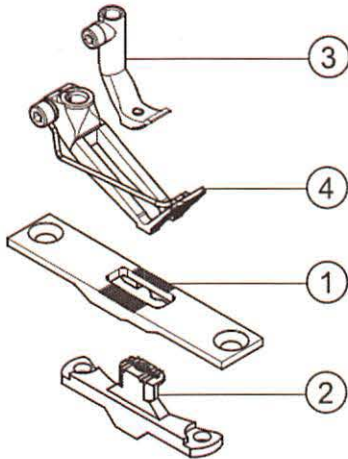

E12

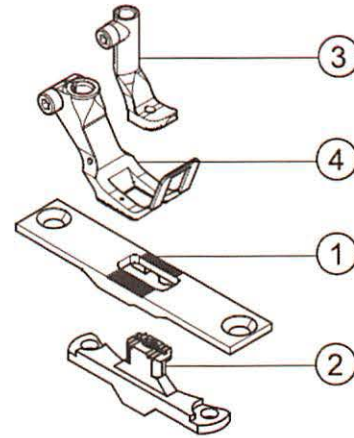

E14



E15

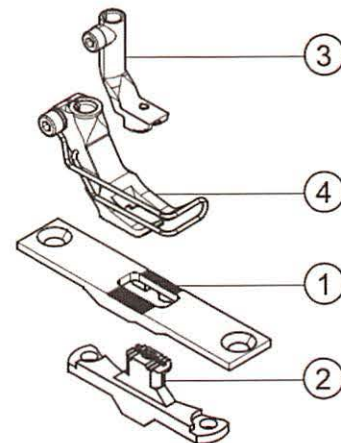

 = Änderung / Modification



E16



E17

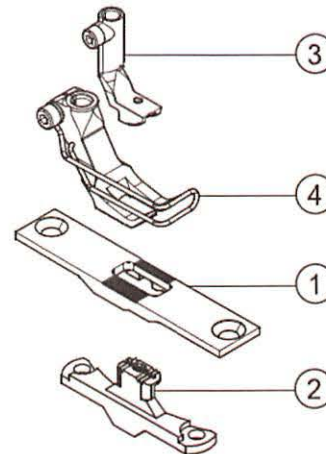

E18

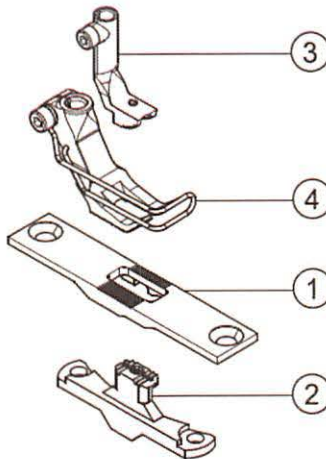

E25
E26

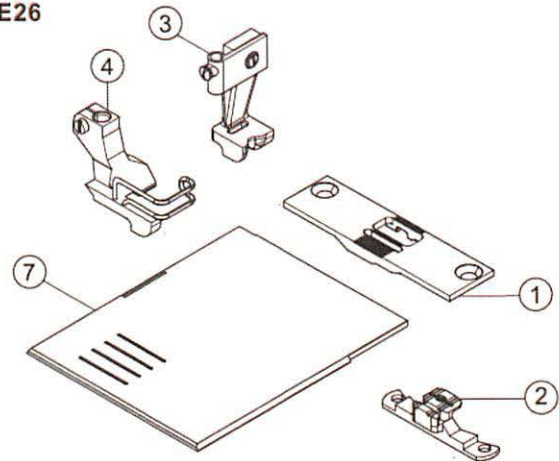

E36

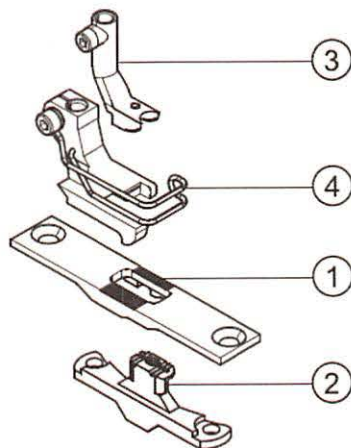

E38

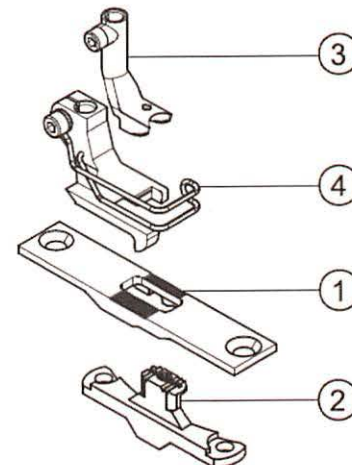

■ = Änderung / Modification



E40
E42
E43
E44
E45
E47
E48

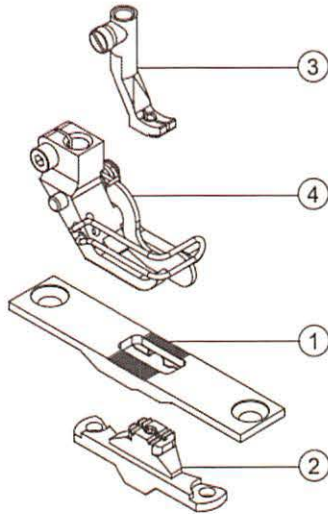

E52
E53
E54
E55
E56
E57
E58

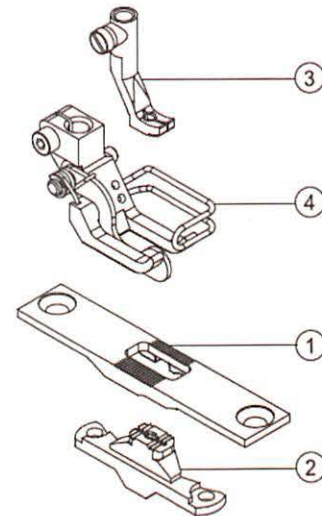

E63
E64
E65
E66
E67

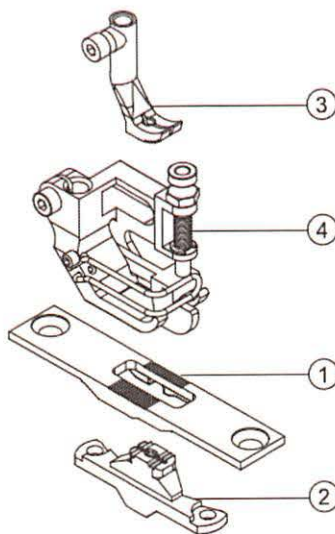

E70/6
E71/6

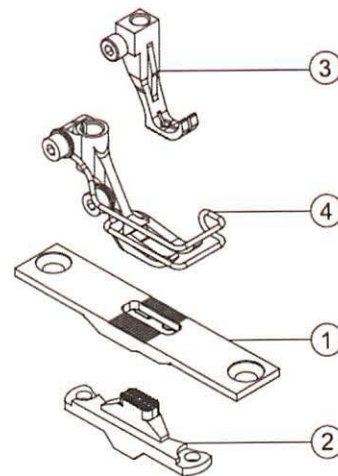

E73
E74
E75
E76
E77

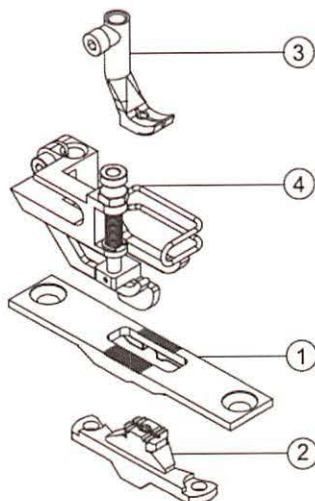

 = Änderung / Modification



E101/0-6
E102/0-9

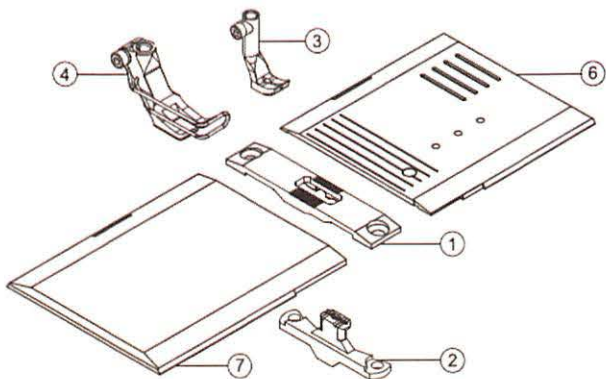

siehe Blatt 2/see page 2

E101-7
E121/0-7

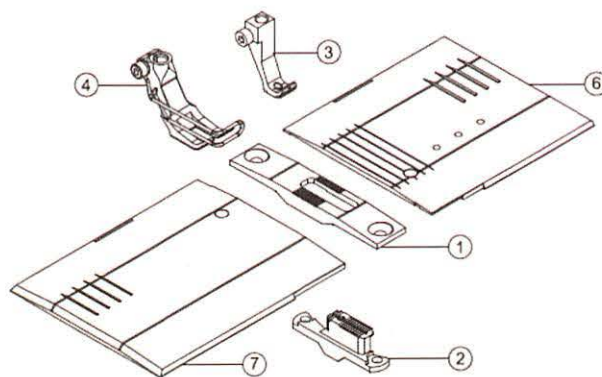

siehe Blatt 2/see page 2

E104/0-9

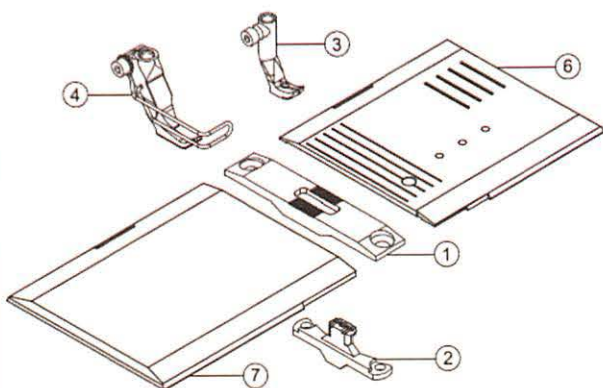

siehe Blatt 2/see page 2

E111/0-6
E112/0-9
E121/0-6
E122/0-9

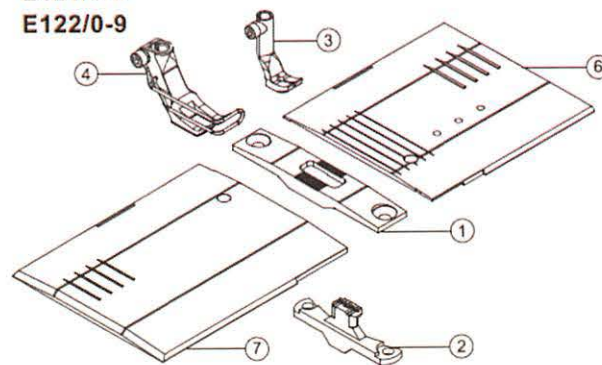

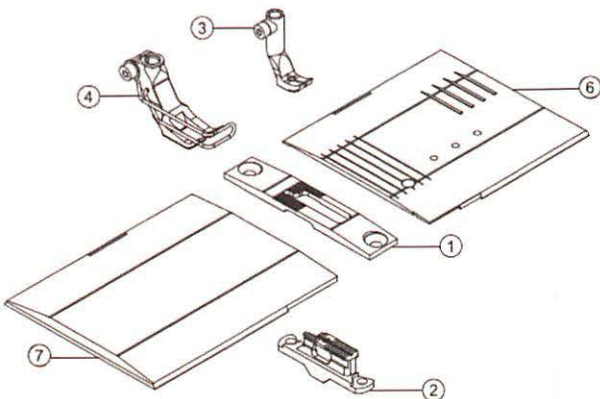

siehe Blatt 2/see page 2

E212/0-6
E212/0-9

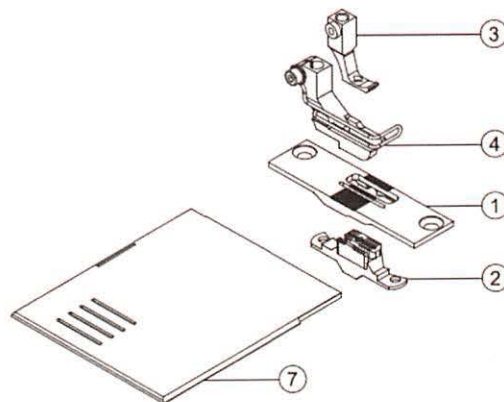

E801/0-6
E802/0-6



 = Änderung / Modification



E21/3-6
E21/3,2-6
E21/4

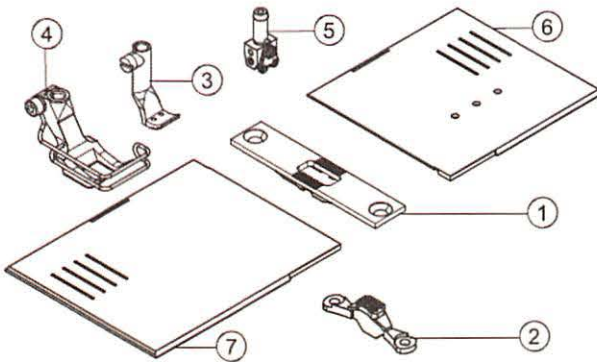

E21/5

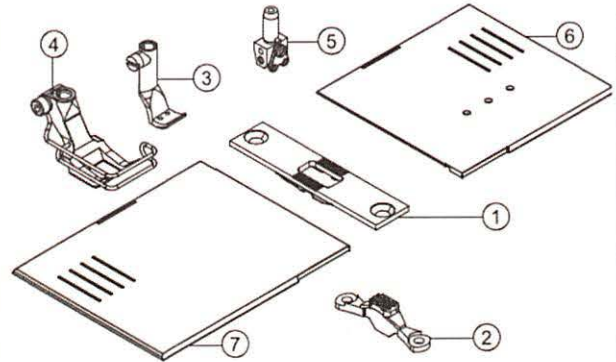

E21/6

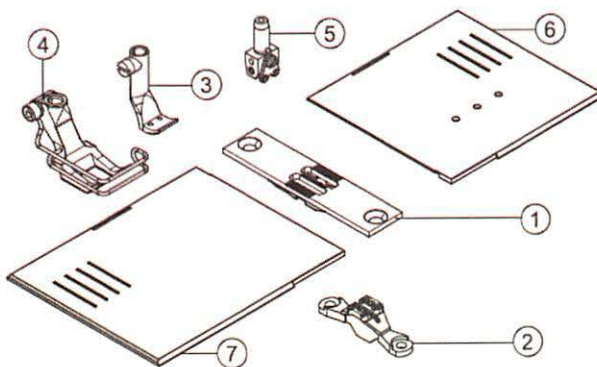

E21/8

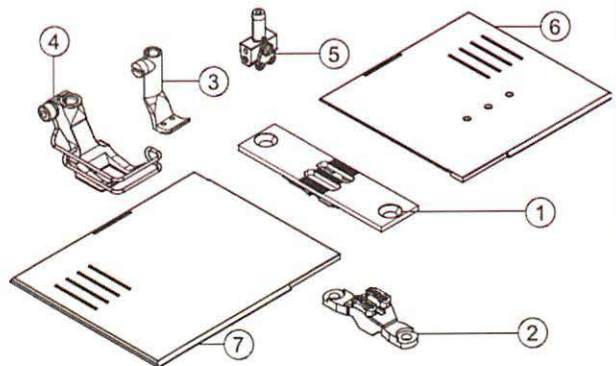

E21/10

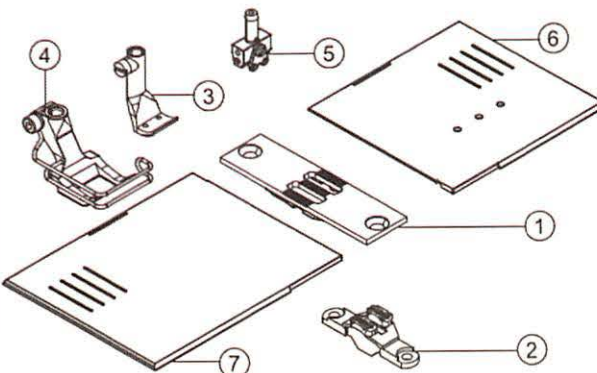

E21/12

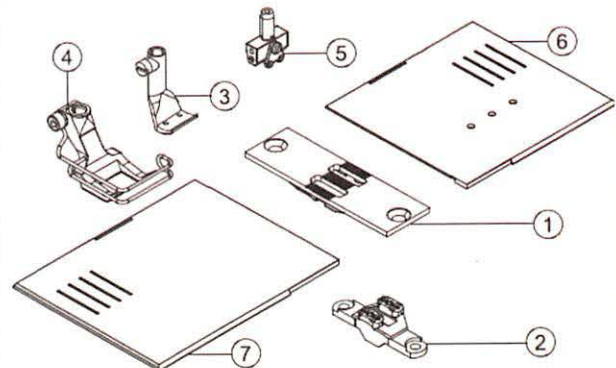

 = Änderung / Modification



E21/14

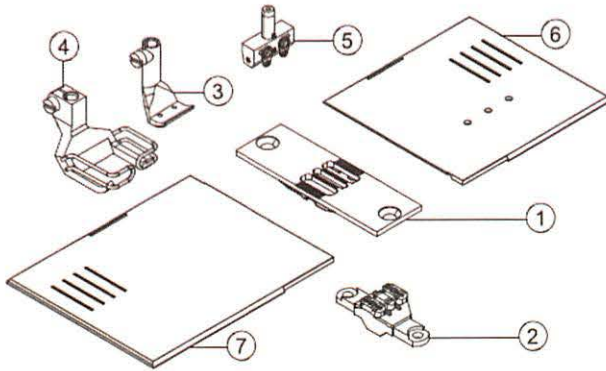

E21/16

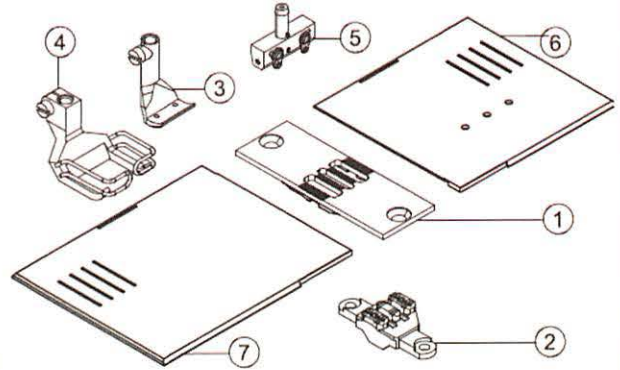

E21/18

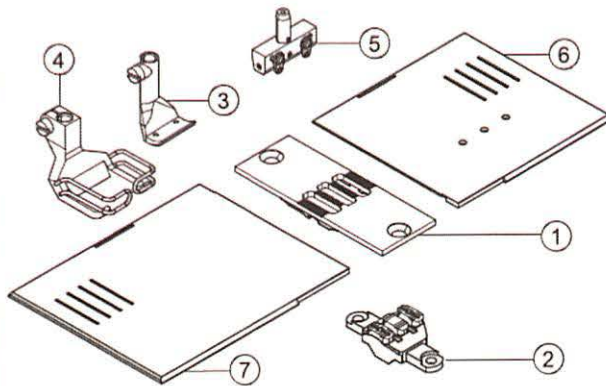

E21/20

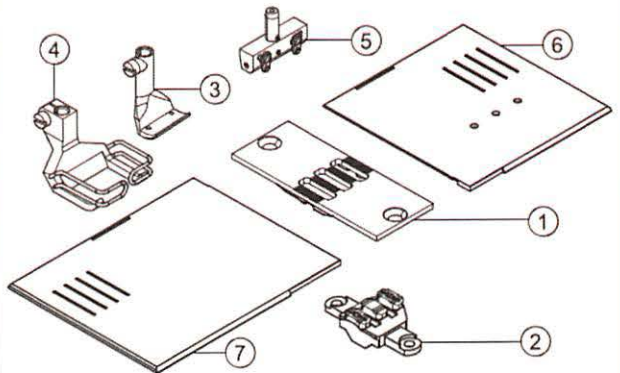

E21/22

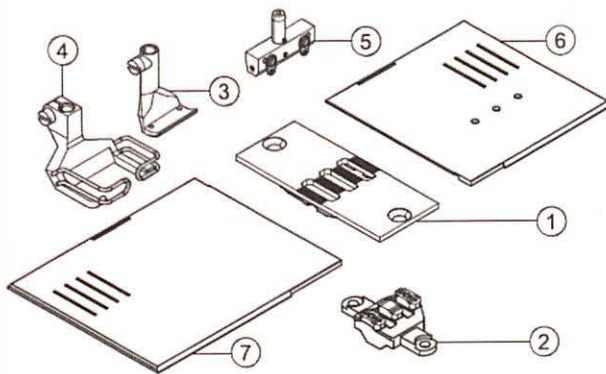

E21/50

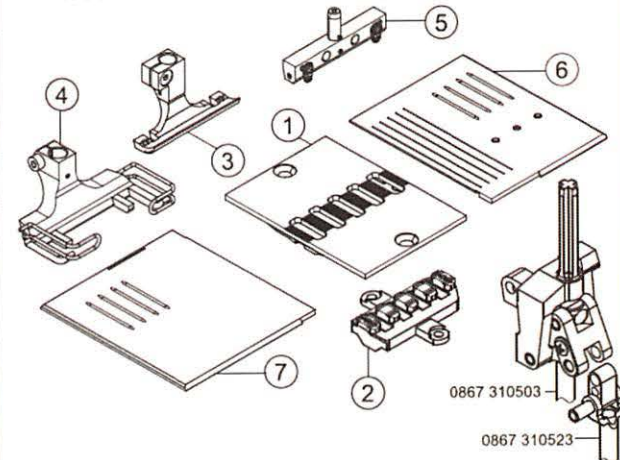

■ = Änderung / Modification



E22/6/9

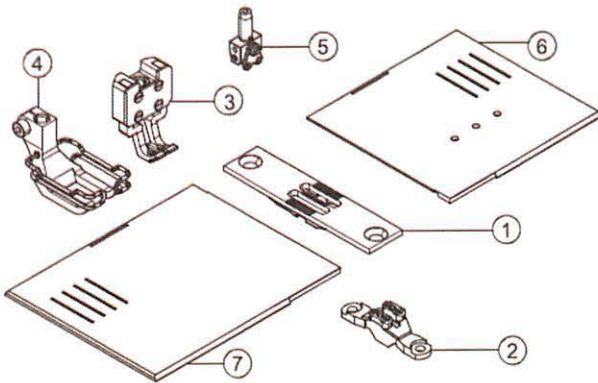

E22/8/6

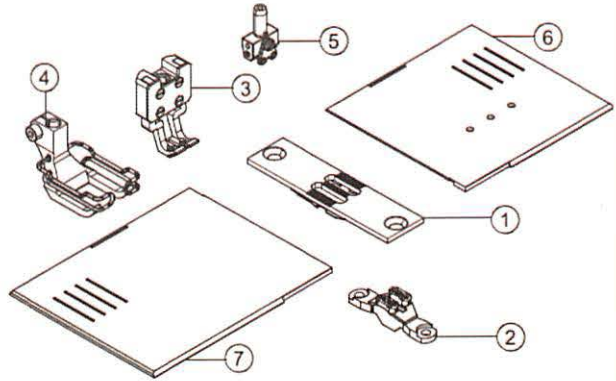

E22/8/9

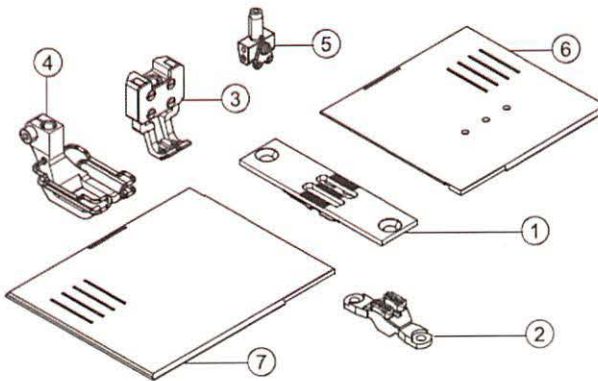

E22/10/6

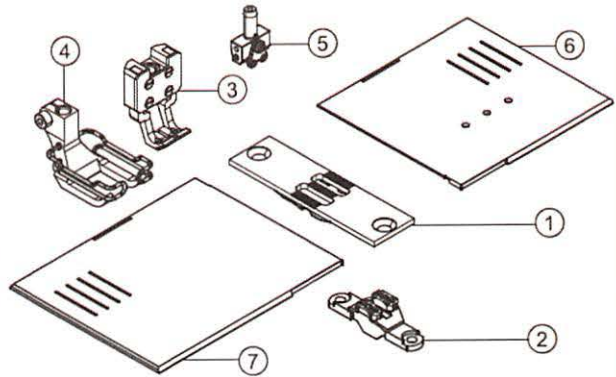

E22/10/9

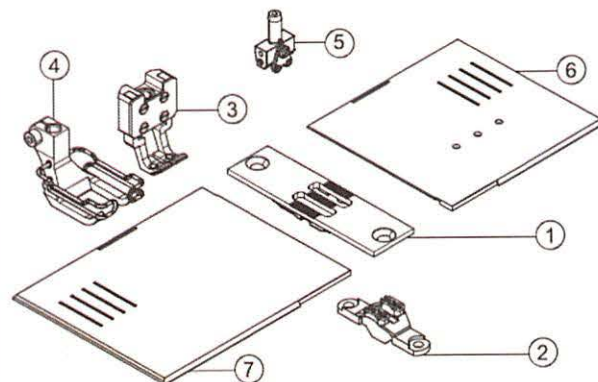

E22/10/12

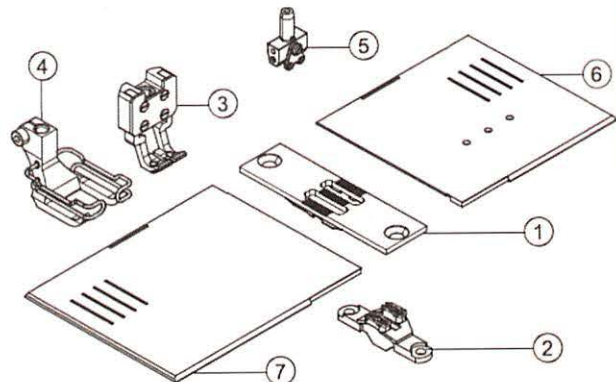

 = Änderung / Modification



E22/12/9

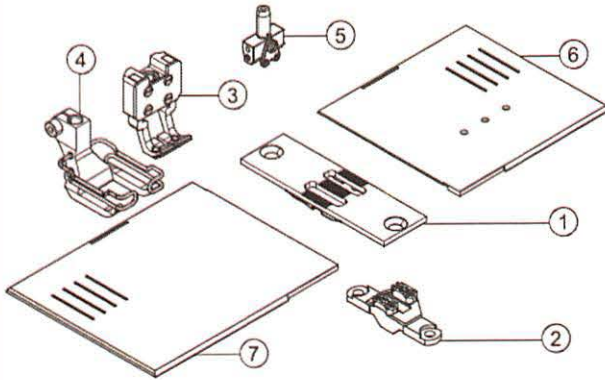

E22/12/12

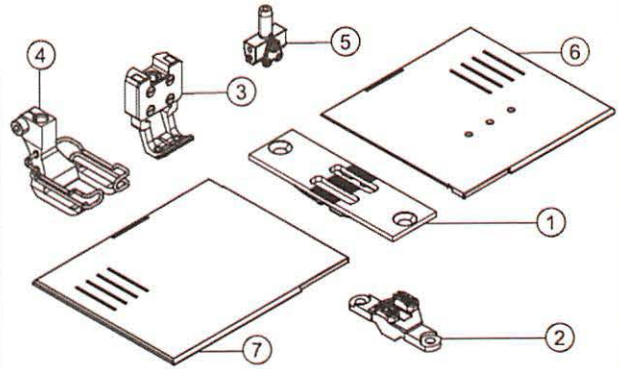

E22/14/12

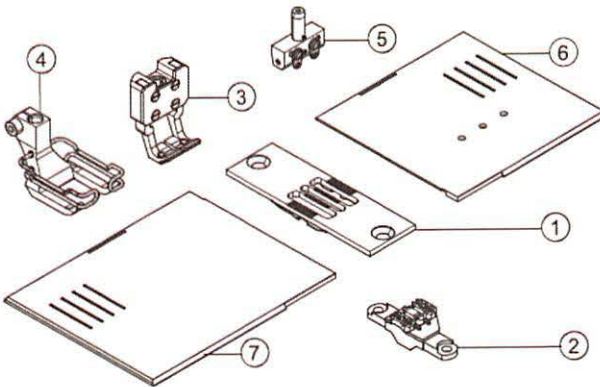

E23/10

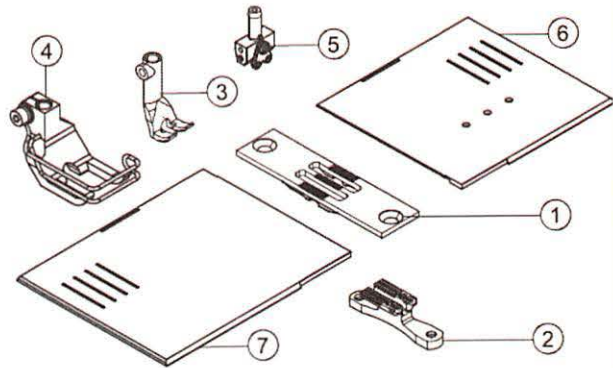

E23/12

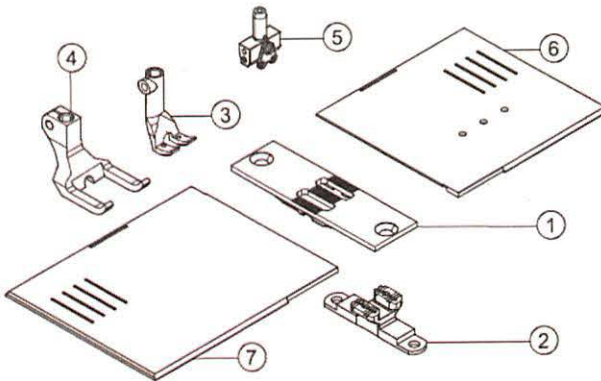

 = Änderung / Modification



E24/6/9

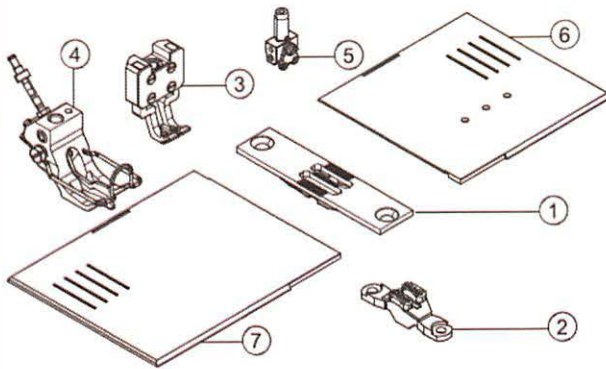

10 siehe Blatt 1/see page 1

E24/8/9

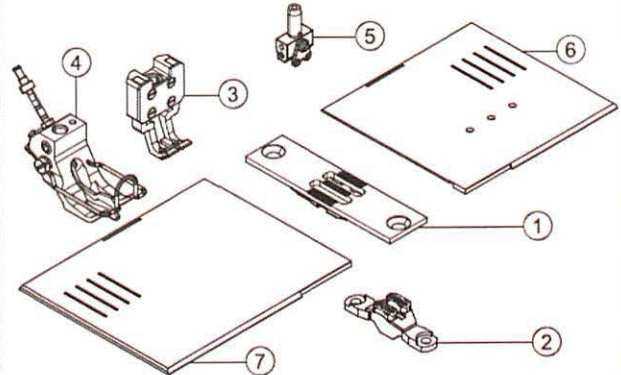

10 siehe Blatt 1/see page 1

E24/10/9

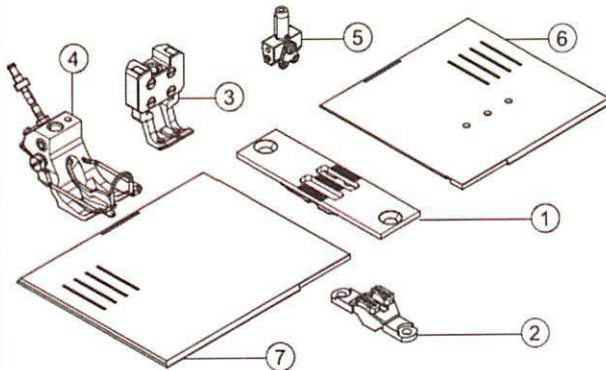

10 siehe Blatt 1/see page 1

E24/12/9

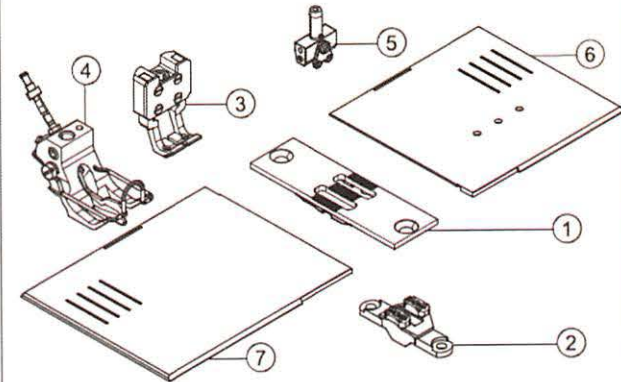

10 siehe Blatt 1/see page 1

E24/8/12

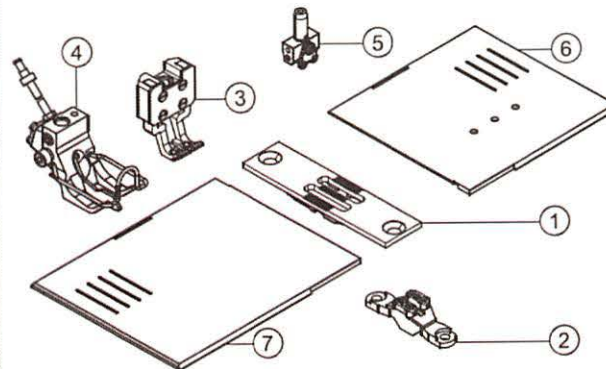

10 siehe Blatt 1/see page 1

E24/10/12

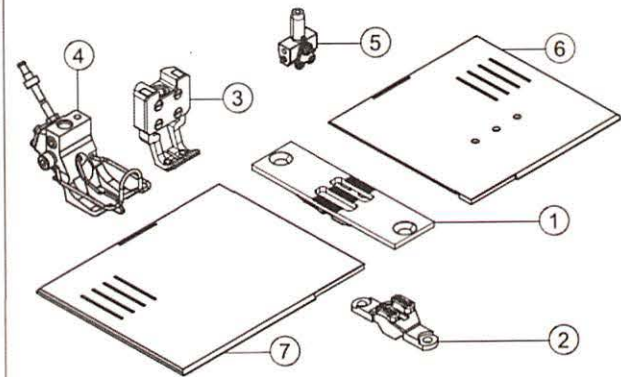

10 siehe Blatt 1/see page 1

■ = Änderung / Modification



E24/12/12

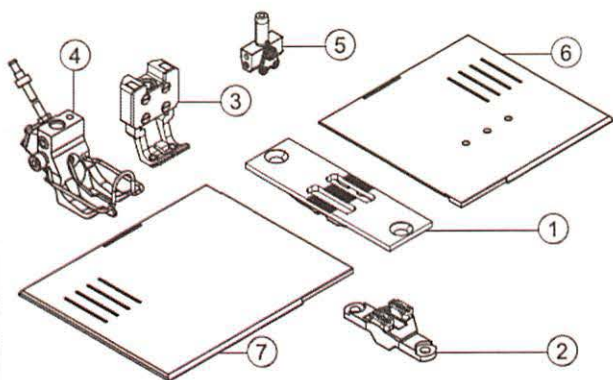

10 siehe Blatt 1/see page 1

E24/14/12

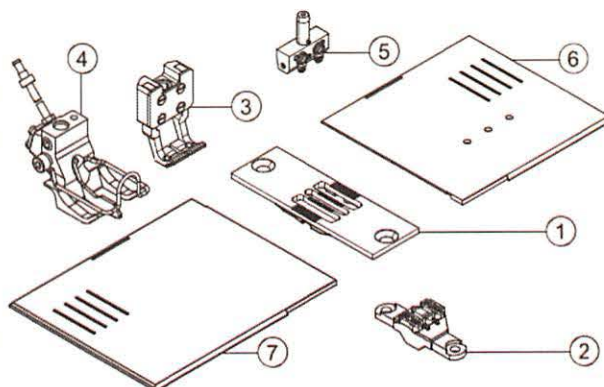

10 siehe Blatt 1/see page 1

E51/6/9
E51/8/9

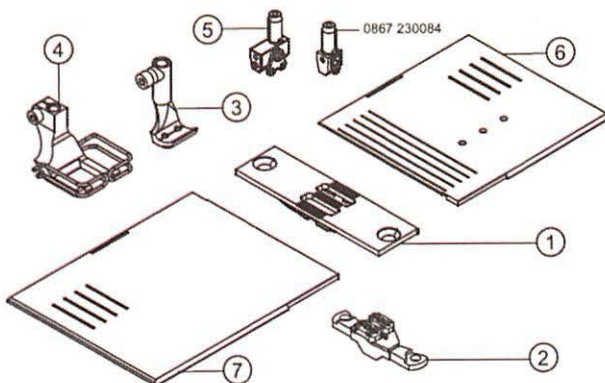

E51/10/9

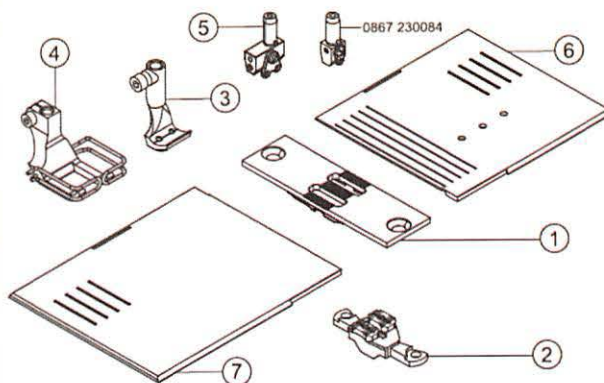

E51/12/9

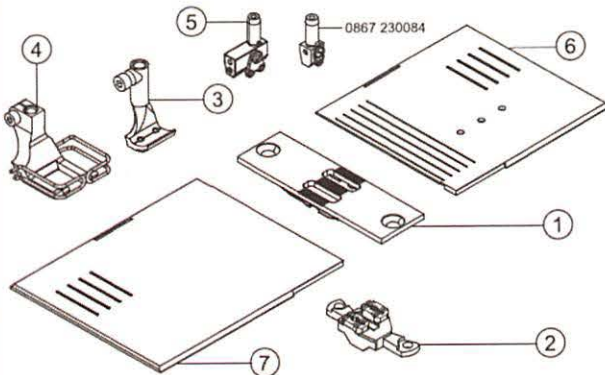

E51/14/9

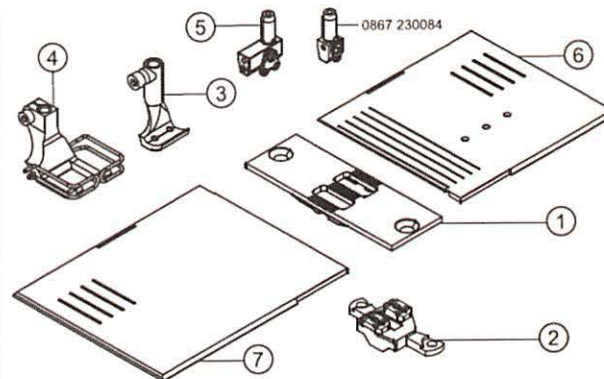

 = Änderung / Modification



E75/3,2/6
E75/4,8/6
E75/6,4/6

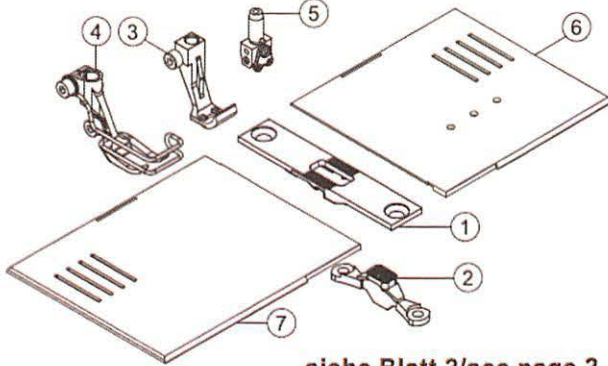

siehe Blatt 2/see page 2

E121/6/6

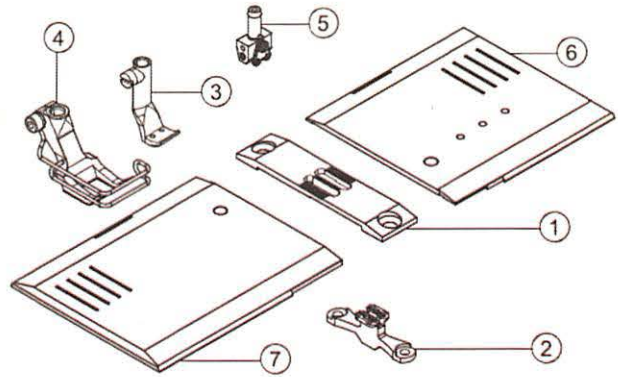

E121/8/6

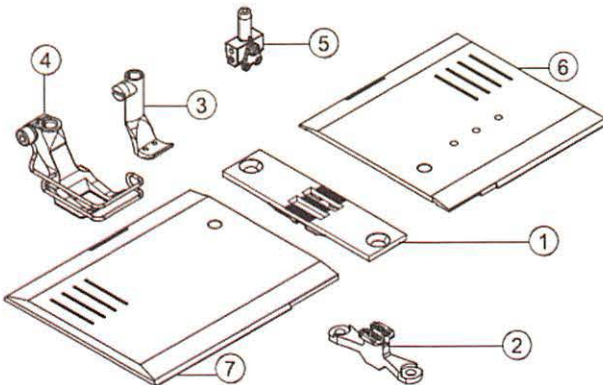

E121/8/7

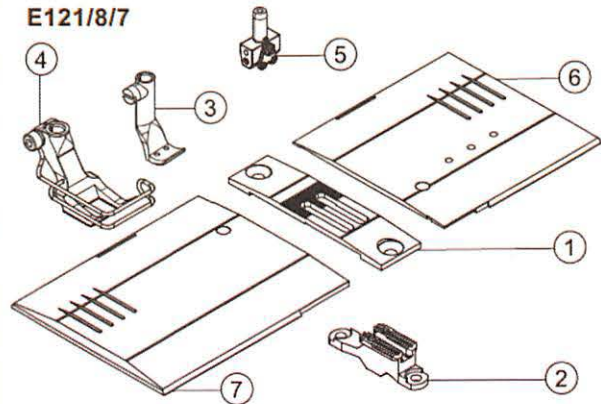

0867 150864



siehe Blatt 2/see page 2

E121/10/6

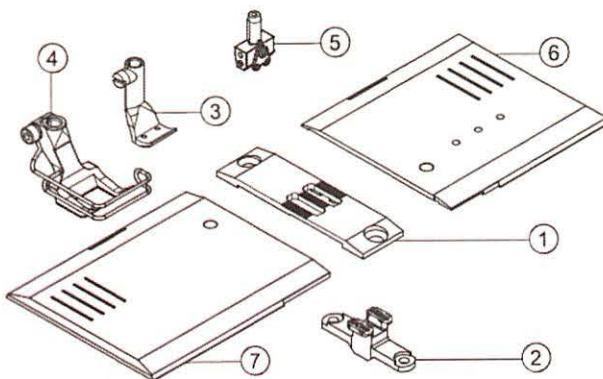

E121/12/6

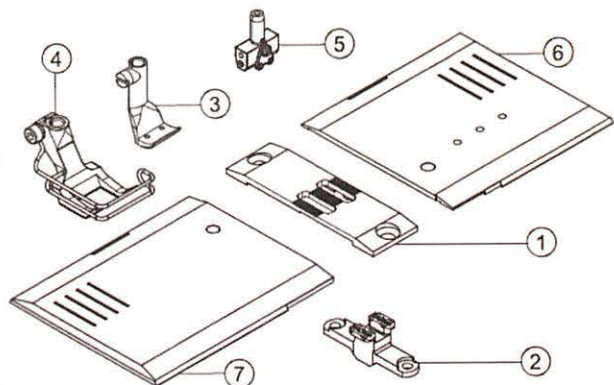

■ = Änderung / Modification



E122/6/9

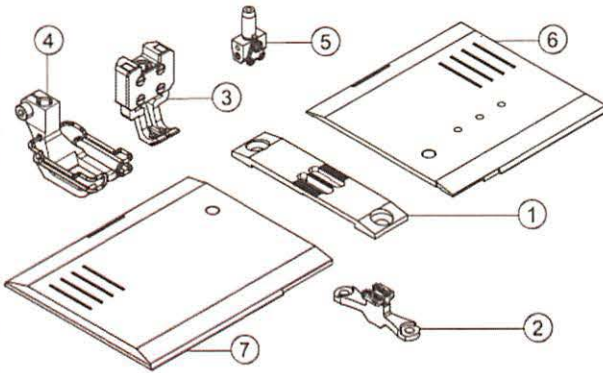

E122/8/9

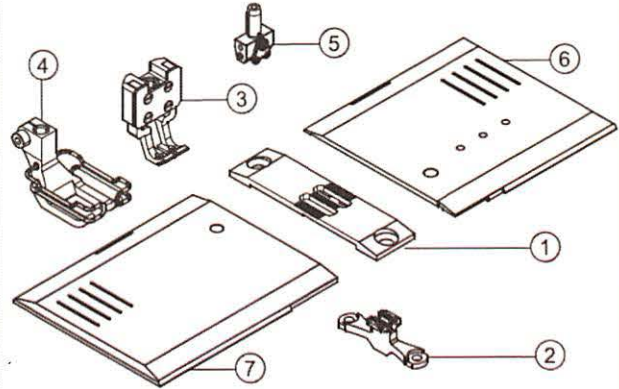

E122/10/9

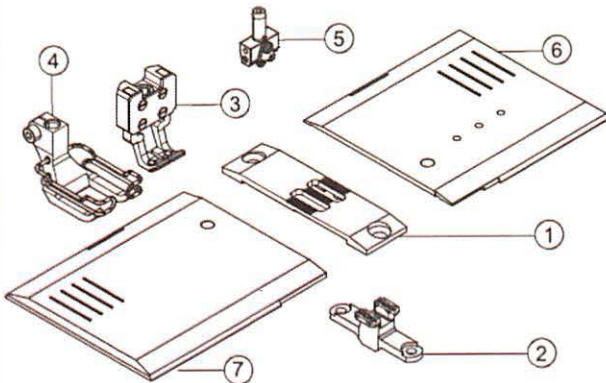

E122/12/9

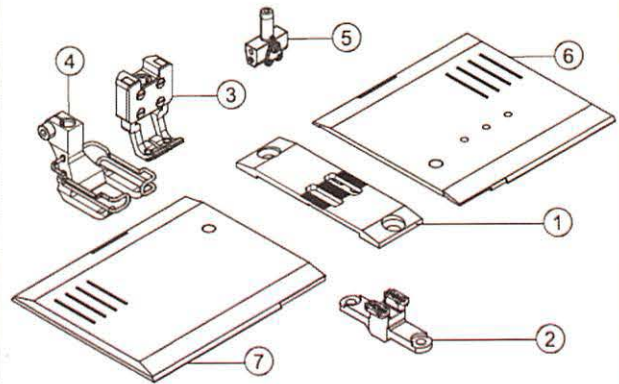

 = Änderung / Modification



Näheinrichtungen 867- M Standard
Sewing equipment

Ausgabe
Edition
02.06

Blatt 16
Page

Fortsetzung Blatt 17
Continued page

E-Nr. E-No. Abb.-Nr. Fig.No.	Für Unterklasse / For Subclass Verwendungszweck / Use	Material No. / Material Nr.	Stichplatte Throat plate		Transporteur Feed dog			Presserfuß Presser foot	Transp. Fuß Feeding foot		Nadelhalter/ Needle holder Nadelsystem / -dicke / Needle system / -size						
			①	①	②	②	②	④	③	③							
			Stichplatte / Throat plate	Schieber, links / Slide, left	Schieber, rechts / Slide, right	Stichtochgröße / Stich hole size mm	Sägeverzahnung / Serrated, oblique mm	Kreuzverzahnung / Cross toothed mm	Dachverzahnung / Roof-shaped mm	Drückenfuß / Presser foot	Unverzahnung / Non toothed	Hüpfenfuß, kreuzverz. / Skipping f., cross toothed	Ausgleichfuß / Compensating foot	Kreuzverzahnung / Cross toothed mm	Unverzahnung / Non toothed		
E1	-190020; -190040; -190122; -190142; -190322; -190342 Näheinrichtung, Nadelstärke Nm 110-140, Stichlänge max. 6 mm, für mittelschweres Nähgut. Sewing equipment, needle size Nm 110-140, stitch length max. 6 mm, for medium weight material.	0867 E00106	0867 200010			2.2 x 3.2	0867 210010			0367 220993				0467 220013			134-35/130
E2	-190020; -190040; -190122; -190142; -190322; -190342 Näheinrichtung, Nadelstärke Nm 110-140, Stichlänge max. 9 mm, für mittelschweres Nähgut. Sewing equipment, needle size Nm 110-140, stitch length max. 9 mm, for medium weight material.	0867 E00209	0867 200020			2.2 x 3.2	0867 210010			0467 220043				0467 220013			134-35/130
E3	-190020; -190040; -190122; -190142; -190322; -190342 Näheinrichtung, Nadelstärke Nm 110-140, Stichlänge max. 12 mm, für mittelschweres Nähgut. Sewing equipment, needle size Nm 110-140, stitch length max. 12 mm, for medium weight material.	0867 E00312	0867 200030			2.2 x 3.2	0867 210010			0768 220013				0467 220013			134-35/130
E4	-190020; -190040; -190122; -190142; -190322; -190342 Näheinrichtung, Nadelstärke Nm 140-170, Stichlänge max. 6 mm, für mittelschweres Nähgut. Sewing equipment, needle size Nm 140-170, stitch length max. 6 mm, for medium weight material.	0867 E00406	0867 200010			3.0 x 3.7	0867 210020			0367 220993				0768 220113			134-35/160
E5	-190020; -190040; -190122; -190142; -190322; -190342 Näheinrichtung, Nadelstärke Nm 140-170, Stichlänge max. 9 mm, für mittelschweres Nähgut. Sewing equipment, needle size Nm 140-170, stitch length max. 9 mm, for medium weight material.	0867 E00509	0867 200020			3.0 x 3.7	0867 210020			0467 220043				0768 220113			134-35/160

☐ = Änderung / Modification



Näheinrichtungen 867- M Standard
Sewing equipment

Ausgabe
Edition
02.06

Blatt 17
Page

Fortsetzung Blatt 18
Continued page

E-Nr. E-No.	Abb.-Nr. Fig.No.	Für Unterklasse / For Subclass Verwendungszweck / Use	Material No. / Material Nr.		Stichplatte	Transporteur	Presserfuß	Transp. Fuß		
			Stichplatte / Throat plate	Schieber, links / Slide, left	Throat plate	Feed dog	Presser foot	Feeding foot		
E6		-190020; -190040; -190122; -190142; -190322; -190342 Näheinrichtung, Nadelstärke Nm 140-170, Stichlänge max. 12 mm, für mittelschweres Nähgut. Sewing equipment, needle size Nm 140-170, stitch length max. 12 mm, for medium weight material.	0867 E00612	0867 200030	①	3,0 x 3,7	0867 210020	0768 220013	0768 220113	134-35/160
E7		-190020; -190040; -190122; -190142; -190322; -190342 Näheinrichtung für kantennahe Näharbeiten, ab 1 mm rechts der Nadel, Nadelstärke Nm 110-140, Stichlänge max. 6 mm, für mittelschweres Nähgut. Sewing equipment for stitching on edges, from 1 mm on the right from the needle, needle size Nm 110-140, stitch length max. 6 mm, for medium weight material.	0867 E00706	0867 200010		2,2 x 3,2	0867 210010	0367 220293	0067 220713	134-35/130
E8		-190020; -190040; -190122; -190142; -190322; -190342 Näheinrichtung für kantennahe Näharbeiten, ab 1 mm links der Nadel, Nadelstärke Nm 110-140, Stichlänge max. 6 mm, für mittelschweres Nähgut. Sewing equipment for stitching on edges, from 1 mm on the left from the needle, needle size Nm 110-140, stitch length max. 6 mm, for medium weight material.	0867 E00806	0867 200010		2,2 x 3,2	0867 210010	0367 220303	0067 220703	134-35/130
E11		-190020; -190040; -190122; -190142; -190322; -190342 Näheinrichtung zum Überklettern starker Quernähte, Nadelstärke Nm 110-140, Stichlänge max. 9 mm, für mittelschweres Nähgut. Sewing equipment for stitching of cross seams in thick material, needle size Nm 110-140, stitch length max. 9 mm, for medium weight material.	0867 E01109	0867 200020		2,2 x 3,2	0867 210010	0767 220013	0467 220483	134-35/130
E12		-190020; -190040; -190122; -190142; -190322; -190342 Näheinrichtung für wattiertes Nähgut, Nadelstärke Nm 110-140, Stichlänge max. 6 mm, für mittelschweres Nähgut. Sewing equipment for padded material, needle size Nm 110-140, stitch length max. 6 mm, for medium weight material.	0867 E01206	0867 200010		2,2 x 3,2	0867 210010	0367 221543	0367 221553	134-35/130

= Änderung / Modification



Näheinrichtungen 867- M Standard
Sewing equipment

Ausgabe
Edition
02.06

Blatt 18
Page

Fortsetzung Blatt 19
Continued page

E-Nr. E-No.	Für Unterklasse / For Subclass	Abb.-Nr. Fig.No.	Verwendungszweck / Use	Material No. / Material Nr.	Stichplatte Throat plate		Transporteur Feed dog		Presserfuß Presser foot		Transp. Fuß Feeding foot		Nadelhalter/Needle holder	Nadelsystem / -dicke / Needle system / -size
					① Stichplatte / Throat plate	Schieber, links / Slide, left	Schieber, rechts / Slide, right	Stichhöhe / Stich hole size mm	Sägeverzahn / Serrated mm	Säge-schrägverzahn / Serrated, oblique mm	Kreuzverzahn / Cross toothed mm	Dachverzahn / Roof-shaped mm		
E14	-190020; -190040; -190122; -190142; -190322; -190342 Näheinrichtung für Kedararbeiten, Kedernut 4 mm, Nadelstärke Nm 110-140, Stichlänge max. 6 mm, für mittelschweres Nähgut. Sewing equipment for welt attaching operations, welt groove 4 mm, needle size Nm 110-140, stitch length max. 6 mm, for medium weight material.	0867 E01406	0867 200010	0867 210010	2,2 x 3,2	0867 210010	0367 220773	0167 220583						134-35/130
E15	-190020; -190040; -190122; -190142; -190322; -190342 Näheinrichtung für Kedararbeiten, Kedernut 5 mm, Nadelstärke Nm 110-140, Stichlänge max. 6 mm, für mittelschweres Nähgut. Sewing equipment for welt attaching operations, welt groove 5 mm, needle size Nm 110-140, stitch length max. 6 mm, for medium weight material.	0867 E01506	0867 200010	0867 210010	2,2 x 3,2	0867 210010	0367 220783	0167 220603						134-35/130
E16	-190020; -190040; -190122; -190142; -190322; -190342 Näheinrichtung für Kedararbeiten, Kedernut 6 mm, Nadelstärke Nm 110-140, Stichlänge max. 6 mm, für mittelschweres Nähgut. Sewing equipment for welt attaching operations, welt groove 6 mm, needle size Nm 110-140, stitch length max. 6 mm, for medium weight material.	0867 E01606	0867 200010	0867 210010	2,2 x 3,2	0867 210010	0367 220793	0167 220363						134-35/130
E17	-190020; -190040; -190122; -190142; -190322; -190342 Näheinrichtung für Kedararbeiten, Kedernut 7 mm, Nadelstärke Nm 110-140, Stichlänge max. 6 mm, für mittelschweres Nähgut. Sewing equipment for welt attaching operations, welt groove 7 mm, needle size Nm 110-140, stitch length max. 6 mm, for medium weight material.	0867 E01706	0867 200010	0867 210010	2,2 x 3,2	0867 210010	0367 220803	0167 220633						134-35/130
E18	-190020; -190040; -190122; -190142; -190322; -190342 Näheinrichtung für Kedararbeiten, Kedernut 8 mm, Nadelstärke Nm 110-140, Stichlänge max. 6 mm, für mittelschweres Nähgut. Sewing equipment for welt attaching operations, welt groove 8 mm, needle size Nm 110-140, stitch length max. 6 mm, for medium weight material.	0867 E01806	0867 200010	0867 210010	2,2 x 3,2	0867 210010	0367 220813	0167 220653						134-35/130

☐ = Änderung / Modification



Näheinrichtungen 867- M Standard
Sewing equipment

Ausgabe
Edition
12.08

Blatt 19
Page

Ersetzt Ausgabe
Replaced edition
02.06

Fortsetzung Blatt 20
Continued page

E-Nr. E-No.	Für Unterklasse / For Subclass	Abb.-Nr. Fig.No.	Verwendungszweck / Use	Material No. / Material Nr.	Stichplatte Throat plate		Transporteur Feed dog				Presserfuß Presser foot	Transp. Fuß Feeding foot	5	Nadelstange/ Needle bar	Nadelsystem / -dcke / Needle system / -size
					①	⑦	②	③	④	③					
E25	-190020; -190040; -190122; -190142; -190322; -190342 Näheinrichtung zum Vor- oder Einnähen von Keder, Kedernut 5 mm, Nadelstärke Nm 110-140, Stichtlänge max. 6 mm, für mittelschweres Nähgut. Sewing equipment for stitching and welt attaching operations, welt groove 5 mm, needle size Nm 110-140, stitch length max. 6 mm, for medium weight material.			0867 E02506	0867 200040	0867 140090		2,2 x 3,2	0867 210040		0367 220653		0067 220924		134-35/130
E26	-190020; -190040; -190122; -190142; -190322; -190342 Näheinrichtung zum Vor- oder Einnähen von Keder, Kedernut 6 mm, Nadelstärke Nm 110-140, Stichtlänge max. 6 mm, für mittelschweres Nähgut Sewing equipment for stitching and welt attaching operations, welt groove 6 mm, needle size Nm 110-140, stitch length max. 6 mm, for medium weight material.			0867 E02606	0867 200040	0867 140090		2,2 x 3,2	0867 210040		0367 220663		0067 220934		134-35/130
E36	-190020; -190040; -190122; -190142; -190322; -190342 Näheinrichtung zum Auf- oder Einnähen von Kordel, Kordelnut 6 mm, Nadelstärke Nm 110-140, Stichtlänge max. 6 mm, für mittelschweres Nähgut. Sewing equipment for stitching and cord attaching operations, cord groove 6 mm, needle size Nm 110-140, stitch length max. 6 mm, for medium weight material.			0867 E03606	0867 200010			2,2 x 3,2	0867 210010		0367 220363		0067 220863		134-35/130
E38	-190020; -190040; -190122; -190142; -190322; -190342 Näheinrichtung zum Auf- oder Einnähen von Kordel, Kordelnut 8 mm, Nadelstärke Nm 110-140, Stichtlänge max. 6 mm, für mittelschweres Nähgut. Sewing equipment for stitching and cord attaching operations, cord groove 8 mm, needle size Nm 110-140, stitch length max. 6 mm, for medium weight material.			0867 E03806	0867 200010			2,2 x 3,2	0867 210010		0367 220373		0367 220363		134-35/130

■ = Änderung / Modification



Näheinrichtungen 867- M Standard

Sewing equipment

Ausgabe
Edition
01.15

Blatt 20
Page

Fortsetzung Blatt 21
Continued page

E-Nr. E-No.	Für Unterklasse / For Subclass	Abb.-Nr. Fig.No.	Verwendungszweck / Use	Material No. / Material Nr.	Stichplatte	Transporteur	Presserfuß	Transp. Fuß	⑤
					Throat plate	Feed dog	Presser foot	Feeding foot	
					①				
					Schieber, links / Slide, left				
					Schieber, rechts / Slide, right				
					Stichlochgröße / Stitch hole size				
					mm				
					Sägeverzahnung / Serrated				
					mm				
					Kreuzverzahnung / Cross toothed				
					mm				
					Dachverzahnung / Roof-shaped				
					mm				
					Drückerfuß / Presser foot				
					mm				
					Unverzahnung / Non toothed				
					Hüpfertfuß, kreuzverz. / Skipping f., cross toothed				
					mm				
					Ausgleichfuß / Compensating foot				
					mm				
					Kreuzverzahnung / Cross toothed				
					mm				
					Unverzahnung / Non toothed				
					Messer/Knife				
					Nadeltange/Needle bar				
					Nadelsystem / -dcke / Needle system / -size				
E40	-160122; -160322; -190020; -190040; -190122; -190142; -190322; -190342 Näheinrichtung mit Kantenanschlag rechts im Drückerfuß - 6 mm, Nadelstärke Nm 110-140, Stichlänge max. 6 mm, für leichtes Nähgut. Sewing equipment with edge stop right of presser foot - 6 mm, needle size Nm 110-140, stitch length max. 6 mm, for light weight material.	0867 E04006	0867 200010	2,2 x 3,2	0867 210010	0867 221124	0467 220013	134-35/130	
E42	-160122; -160322; -190020; -190040; -190122; -190142; -190322; -190342 Näheinrichtung mit Kantenanschlag rechts im Drückerfuß - 2 mm, Nadelstärke Nm 110-140, Stichlänge max. 6 mm, für leichtes Nähgut. Sewing equipment with edge stop right of presser foot - 2 mm, needle size Nm 110-140, stitch length max. 6 mm, for light weight material.	0867 E04206	0867 200010	2,2 x 3,2	0867 210010	0867 221064	0867 221183	134-35/130	
E43	-160122; -160322; -190020; -190040; -190122; -190142; -190322; -190342 Näheinrichtung mit Kantenanschlag rechts im Drückerfuß - 3 mm, Nadelstärke Nm 110-140, Stichlänge max. 6 mm, für leichtes Nähgut. Sewing equipment with edge stop right of presser foot - 3 mm, needle size Nm 110-140, stitch length max. 6 mm, for light weight material.	0867 E04306	0867 200010	2,2 x 3,2	0867 210010	0867 221084	0867 220383	134-35/130	
E44	-160122; -160322; -190020; -190040; -190122; -190142; -190322; -190342 Näheinrichtung mit Kantenanschlag rechts im Drückerfuß - 4 mm, Nadelstärke Nm 110-140, Stichlänge max. 6 mm, für leichtes Nähgut. Sewing equipment with edge stop right of presser foot - 4 mm, needle size Nm 110-140, stitch length max. 6 mm, for light weight material.	0867 E04406	0867 200010	2,2 x 3,2	0867 210010	0867 220864	0367 220203	134-35/130	
E45	-160122; -160322; -190020; -190040; -190122; -190142; -190322; -190342 Näheinrichtung mit Kantenanschlag rechts im Drückerfuß - 5 mm, Nadelstärke Nm 110-140, Stichlänge max. 6 mm, für leichtes Nähgut. Sewing equipment with edge stop right of presser foot - 5 mm, needle size Nm 110-140, stitch length max. 6 mm, for light weight material.	0867 E04506	0867 200010	2,2 x 3,2	0867 210010	0867 221104	0467 220013	134-35/130	
E47	-160122; -160322; -190020; -190040; -190122; -190142; -190322; -190342 Näheinrichtung mit Kantenanschlag rechts im Drückerfuß - 7 mm, Nadelstärke Nm 110-140, Stichlänge max. 6 mm, für leichtes Nähgut. Sewing equipment with edge stop right of presser foot - 7 mm, needle size Nm 110-140, stitch length max. 6 mm, for light weight materia	0867 E04706	0867 200010	2,2 x 3,2	0867 210010	0867 221144	0467 220013	134-35/130	

= Änderung / Modification



Näheinrichtungen **867- M Standard**
Sewing equipment

Ausgabe
Edition
01.15

Blatt 21
Page

Fortsetzung Blatt 22
Continued page

E-Nr. E-No.	Für Unterklasse / For Subclass	Abb.-Nr. Fig.No.	Verwendungszweck / Use	Material No. / Material Nr.	Stichplatte Throat plate		Transporteur Feed dog				Presserfuß Presser foot	Transp. Fuß Feeding foot		Messer/Knife	Nadelstange/Needle bar	Nadelsystem / -dcke / Needle system / -size	
					①												
E48	-160122; -160322; -190020; -190040; -190122; -190142; -190322; -190342 Näheinrichtung mit Kantenanschlag rechts im Drückerfuß - 8 mm, Nadelstärke Nm 110-140, Stichlänge max. 6 mm, für leichtes Nähgut. Sewing equipment with edge stop right of presser foot - 8 mm, needle size Nm 110-140, stitch length max. 6 mm, for light weight material.	0867 E04806	0867 200010	0867 200010		2,2 x 3,2	0867 210010				0867 221164			0467 220013			134-35/130
E52	-160122; -160322; -190020; -190040; -190122; -190142; -190322; -190342 Näheinrichtung mit Kantenanschlag links im Drückerfuß - 2 mm, Nadelstärke Nm 110-140, Stichlänge max. 6 mm, für leichtes Nähgut. Sewing equipment with edge stop left of presser foot - 2 mm, needle size Nm 110-140, stitch length max. 6 mm, for light weight material.	0867 E05206	0867 200010	0867 200010		2,2 x 3,2	0867 210010				0867 221074			0867 221193			134-35/130
E53	-160122; -160322; -190020; -190040; -190122; -190142; -190322; -190342 Näheinrichtung mit Kantenanschlag links im Drückerfuß - 3 mm, Nadelstärke Nm 110-140, Stichlänge max. 6 mm, für leichtes Nähgut. Sewing equipment with edge stop left of presser foot - 3 mm, needle size Nm 110-140, stitch length max. 6 mm, for light weight material.	0867 E05306	0867 200010	0867 200010		2,2 x 3,2	0867 210010				0867 221094			0867 220393			134-35/130
E54	-160122; -160322; -190020; -190040; -190122; -190142; -190322; -190342 Näheinrichtung mit Kantenanschlag links im Drückerfuß - 4 mm, Nadelstärke Nm 110-140, Stichlänge max. 6 mm, für leichtes Nähgut. Sewing equipment with edge stop left of presser foot - 4 mm, needle size Nm 110-140, stitch length max. 6 mm, for light weight material.	0867 E05406	0867 200010	0867 200010		2,2 x 3,2	0867 210010				0867 220804			0367 220203			134-35/130
E55	-160122; -160322; -190020; -190040; -190122; -190142; -190322; -190342 Näheinrichtung mit Kantenanschlag links im Drückerfuß - 5 mm, Nadelstärke Nm 110-140, Stichlänge max. 6 mm, für leichtes Nähgut. Sewing equipment with edge stop left of presser foot - 5 mm, needle size Nm 110-140, stitch length max. 6 mm, for light weight material.	0867 E05506	0867 200010	0867 200010		2,2 x 3,2	0867 210010				0867 221114			0467 220013			134-35/130
E56	-160122; -160322; -190020; -190040; -190122; -190142; -190322; -190342 Näheinrichtung mit Kantenanschlag links im Drückerfuß - 6 mm, Nadelstärke Nm 110-140, Stichlänge max. 6 mm, für leichtes Nähgut. Sewing equipment with edge stop left of presser foot - 6 mm, needle size Nm 110-140, stitch length max. 6 mm, for light weight material.	0867 E05606	0867 200010	0867 200010		2,2 x 3,2	0867 210010				0867 221134			0467 220013			134-35/130

= Änderung / Modification



Näheinrichtungen 867- M Standard

Ausgabe
Edition
01.15

Blatt 22
Page

Fortsetzung Blatt 23
Continued page

E-Nr. E-No.	Für Unterklasse / For Subclass	Abb.-Nr. Fig.No.	Verwendungszweck / Use	Material No. / Material Nr.		Stichplatte	Transporteur	Presserfuß	Transp. Fuß	Nadelstange / Needle bar	Nadelsystem / -dicke / Needle system / -size					
				Stichplatte / Throat plate	Transporteur / Feed dog	Presserfuß / Presser foot	Transp. Fuß / Feeding foot									
				①												
				Schieber, links / Slide, left	Schieber, rechts / Slide, right	Stichhöhe / Stichhöhe / Stich hole size mm	Sägeverzahnung / Serrated, oblique mm	Kreuzverzahnung / Cross toothed mm	Dachverzahnung / Roof-shaped mm	Drückerfuß / Presser foot	Unverzahnung / Non toothed	Hüpfertuß, kreuzverz. / Skipping f., cross toothed	Ausgleichfuß / Compensating foot	Kreuzverzahnung / Cross toothed mm	Unverzahnung / Non toothed	Messerknife
E57	-160122; -160322; -190020; -190040; -190122; -190142; -190322; -190342		Näheinrichtung mit Kantenanschlag links im Drückerfuß - 7 mm, Nadelstärke Nm 110-140, Stichtlänge max. 6 mm, für leichtes Nähgut. Sewing equipment with edge stop left of presser foot - 7 mm, needle size Nm 110-140, stitch length max. 6 mm, for light weight material.	0867 E05706	0867 200010	2,2 x 3,2	0867 210010			0867 221154				0467 220013		134-35/130
E58	-160122; -160322; -190020; -190040; -190122; -190142; -190322; -190342		Näheinrichtung mit Kantenanschlag links im Drückerfuß - 8 mm, Nadelstärke Nm 110-140, Stichtlänge max. 6 mm, für leichtes Nähgut. Sewing equipment with edge stop left of presser foot - 8 mm, needle size Nm 110-140, stitch length max. 6 mm, for light weight material.	0867 E05806	0867 200010	2,2 x 3,2	0867 210010			0867 221174				0467 220013		134-35/130
E63	-190020; -190040; -190122; -190142; -190322; -190342		Näheinrichtung mit Kantenanschlag rechts im Drückerfuß - 3 mm, Nadelstärke Nm 110-140, Stichtlänge max. 12 mm, für schweres Nähgut. Sewing equipment with edge stop right of presser foot - 3 mm, needle size Nm 110-140, stitch length max. 12 mm, for heavy weight material.	0867 E06312	0867 200030	2,2 x 3,2	0867 210010			0867 220924				0867 220333		134-35/130
E64	-190020; -190040; -190122; -190142; -190322; -190342		Näheinrichtung mit Kantenanschlag rechts im Drückerfuß - 4 mm, Nadelstärke Nm 110-140, Stichtlänge max. 12 mm, für schweres Nähgut. Sewing equipment with edge stop right of presser foot - 4 mm, needle size Nm 110-140, stitch length max. 12 mm, for heavy weight material.	0867 E06412	0867 200030	2,2 x 3,2	0867 210010			0867 220964				0367 220203		134-35/130
E65	-190020; -190040; -190122; -190142; -190322; -190342		Näheinrichtung mit Kantenanschlag rechts im Drückerfuß - 5 mm, Nadelstärke Nm 110-140, Stichtlänge max. 12 mm, für schweres Nähgut. Sewing equipment with edge stop right of presser foot - 5 mm, needle size Nm 110-140, stitch length max. 12 mm, for heavy weight material.	0867 E06512	0867 200030	2,2 x 3,2	0867 210010			0867 220744				0467 220013		134-35/130

☐ = Änderung / Modification



Näheinrichtungen 867- M Standard

Sewing equipment

Ausgabe
Edition
01.15

Blatt 23
Page

Ersetzt Ausgabe
Replaced edition
01.13

Fortsetzung Blatt 24
Continued page

E-Nr. E-No.	Für Unterklasse / For Subclass	Material No. / Material Nr.	Stichplatte	Transporteur	Presserfuß	Transp. Fuß	Nadelhalter/ Needle holder	Nadelsystem / -d/cke / Needle system / -size									
			Throat plate	Feed dog	Presser foot	Feeding foot											
Abb.-Nr. Fig.No.	Verwendungszweck / Use		①		②	③	④	⑤									
			Schleiber, links / Slide, left	Schleiber, rechts / Slide, right	Stichlochgröße / Stitch hole size mm	Sägezahn / Serrated mm	Säge-schrägzahn / Serrated, oblique mm	Kreuzverzahn / Cross toothed mm	Dachverzahn / Roof-shaped mm	Drückerfuß / Presser foot	Unverzahn / Non toothed	Hüpfenfuß, kreuzverz. / Skipping f., cross toothed	Ausgleichfuß / Compensating foot	Kreuzverzahn / Cross toothed mm	Unverzahn / Non toothed	Abdeckplatte / Cover plate	
E66	-190020; -190040; -190122; -190142; -190322; -190342 Näheinrichtung mit Kantenanschlag rechts im Drückerfuß - 6 mm, Nadelstärke Nm 110-140, Stichlänge max. 12 mm, für schweres Nähgut. Sewing equipment with edge stop right of presser foot - 6 mm, needle size Nm 110-140, stitch length max. 12 mm, for heavy weight material	0867 E06612 0867 200030			2,2 x 3,2	0867 210010			0867 221004					0467 220013			134-35/130
E67	-190020; -190040; -190122; -190142; -190322; -190342 Näheinrichtung mit Kantenanschlag rechts im Drückerfuß - 7 mm, Nadelstärke Nm 110-140, Stichlänge max. 12 mm, für schweres Nähgut. Sewing equipment with edge stop right of presser foot - 7 mm, needle size Nm 110-140, stitch length max. 12 mm, for heavy weight material	0867 E06712 0867 200030			2,2 x 3,2	0867 210010			0867 221044					0467 220013			134-35/130
E70/6	-160122; -160322 Näheinrichtung, Nadelstärke Nm 80-120, Stichlänge max. 6 mm, für leichtes und mittelschweres Nähgut. Sewing equipment, needle size Nm 80-120, stitch length max. 6 mm, for light and medium weight material.	0867 E07006 0867 201200			∅ 2	0867 211200			0867 220644					0867 220604			134-35/110
E71/6	-160122; -160322 Näheinrichtung, Nadelstärke Nm 80-120, Stichlänge max. 6 mm, für leichtes und mittelschweres Nähgut. Sewing equipment, needle size Nm 80-120, stitch length max. 6 mm, for light and medium weight material.	0867 E07106 0867 201200			∅ 2	0867 211210			0867 220654					0867 220614			134-35/110
E73	-190020; -190040; -190122; -190142; -190322; -190342 Näheinrichtung mit Kantenanschlag links im Drückerfuß - 3 mm, Nadelstärke Nm 110-140, Stichlänge max. 12 mm, für schweres Nähgut. Sewing equipment with edge stop left of presser foot - 3 mm, needle size Nm 110-140, stitch length max. 12 mm, for heavy weight material.	0867 E07312 0867 200030			2,2 x 3,2	0867 210010			0867 220904					0867 220793			134-35/130

□ = Änderung / Modification



Näheinrichtungen 867- M Standard
Sewing equipment

Ausgabe
Edition
01.15

Blatt 24
Page

Fortsetzung Blatt 25
Continued page

E-Nr. E-No.	Für Unterklasse / For Subclass	Abb.-Nr. Fig.No.	Verwendungszweck / Use	Stichplatte Throat plate		Transporteur Feed dog		Presserfuß Presser foot		Transp. Fuß Feeding foot		Abdeckplatte / Cover plate	Nadelhalter / Needle holder	Nadelsystem / -size						
				①	②	③	④	⑤												
				Material No. / Material Nr.	Stichplatte / Throat plate	Schieber, links / Slide, left	Schieber, rechts / Slide, right	Stichlochgröße / Stitch hole size mm	Sägeverzahn / Serrated mm	Säge-schrägverzahn / Serrated, oblique mm	Kreuzverzahn / Cross toothed mm	Dachverzahn / Roof-shaped mm	Drückerfuß / Presser foot	Unverzahn / Non toothed	Hüpfuß, kreuzverz. / Skipping f., cross toothed	Ausgleichfuß / Compensating foot	Kreuzverzahn / Cross toothed mm	Unverzahn / Non toothed		
E74	-190020; -190040; -190122; -190142; -190322; -190342 Näheinrichtung mit Kantenanschlag links im Drückerfuß - 4 mm, Nadelstärke Nm 110-140, Stichlänge max. 12 mm, für schweres Nähgut. Sewing equipment with edge stop left of presser foot - 4 mm, needle size Nm 110-140, stitch length max. 12 mm, for heavy weight material.			0867 E07412	0867 200030			2,2 x 3,2	0867 210010				0867 220944					0367 220203		134-35/110
E75	-190020; -190040; -190122; -190142; -190322; -190342 Näheinrichtung mit Kantenanschlag links im Drückerfuß - 5 mm, Nadelstärke Nm 110-140, Stichlänge max. 12 mm, für schweres Nähgut. Sewing equipment with edge stop left of presser foot - 5 mm, needle size Nm 110-140, stitch length max. 12 mm, for heavy weight material.			0867 E07512	0867 200030			2,2 x 3,2	0867 210010				0867 220704					0467 220013		134-35/130
E76	-190020; -190040; -190122; -190142; -190322; -190342 Näheinrichtung mit Kantenanschlag links im Drückerfuß - 6 mm, Nadelstärke Nm 110-140, Stichlänge max. 12 mm, für schweres Nähgut. Sewing equipment with edge stop left of presser foot - 6 mm, needle size Nm 110-140, stitch length max. 12 mm, for heavy weight material.			0867 E07612	0867 200030			2,2 x 3,2	0867 210010				0867 220984					0467 220013		134-35/130
E77	-190020; -190040; -190122; -190142; -190322; -190342 Näheinrichtung mit Kantenanschlag links im Drückerfuß - 7 mm, Nadelstärke Nm 110-140, Stichlänge max. 12 mm, für schweres Nähgut. Sewing equipment with edge stop left of presser foot - 7 mm, needle size Nm 110-140, stitch length max. 12 mm, for heavy weight material.			0867 E07712	0867 200030			2,2 x 3,2	0867 210010				0867 221024					0467 220013		134-35/130

☐ = Änderung / Modification



Näheinrichtungen 867- M Standard

Sewing equipment

Ausgabe
Edition
09.17

Blatt 25
Page

Ersetzt Ausgabe
Replaced edition
01.15

Fortsetzung Blatt 26
Continued page

E-Nr. E-No.	Für Unterklasse / For Subclass	Abb.-Nr. Fig.No.	Verwendungszweck / Use	Material No. / Material Nr.	Stichplatte Throat plate			Transporteur Feed dog			Presserfuß Presser foot		Transp. Fuß Feeding foot		Abdeckplatte / Cover plate	Nadelhalter / Needle holder	Nadelsystem / -dsize / Needle system / -size	
					①	⑦	⑥	②	③	④	⑤							
E101/0-6	-190125; -190145; -190425; -190445 Näheinrichtung, Nadelstärke Nm 110-140, Stichlänge max. 6 mm, für mittelschweres Nähgut; mit Kurzfadenabschneider. Sewing equipment, needle size Nm 110-140, stitch length max. 6 mm, for medium weight material; with short thread trimmer.			0867 E10106	0867 200050	0867 140260	0867 140163	2,2 x 3,2	0867 210050			0367 220993			0467 220013			134-35/120
E101-7	-190125; -190145; -190425; -190445 Näheinrichtung, Nadelstärke Nm 110-140, Stichlänge max. 7 mm, für mittelschweres Nähgut; mit Kurzfadenabschneider. Sewing equipment, needle size Nm 110-140, stitch length max. 7 mm, for medium weight material; with short thread trimmer.			0867 E10107	0867 200340	0867 140410	0867 141113	2,2 x 3,2	0867 210340			0867 220774			0867 220783			134-35/120
E102/0-9	-190125; -190145; -190425; -190445 Näheinrichtung, Nadelstärke Nm 110-140, Stichlänge max. 9 mm, für mittelschweres Nähgut; mit Kurzfadenabschneider. Sewing equipment, needle size Nm 110-140, stitch length max. 9 mm, for medium weight material; with short thread trimmer.			0867 E10209	0867 200060	0867 140260	0867 140163	2,2 x 3,2	0867 210050			0467 220043			0467 220013			134-35/120
E104/0-9	-190125; -190145; -190425; -190445 Näheinrichtung, Nadelstärke Nm 110-140, Stichlänge max. 9 mm, für mittelschweres Nähgut; mit Kurzfadenabschneider. Sewing equipment, needle size Nm 110-140, stitch length max. 9 mm, for medium weight material; with short thread trimmer.			0867 E10409	0867 200180	0867 140260	0867 140163	2,2 x 3,2	0867 210180			0867 220343			0867 220333			134-35/120

☐ = Änderung / Modification



Näheinrichtungen 867- M Standard

Sewing equipment

Ausgabe
Edition
09.17

Blatt 26
Page

Ersetzt Ausgabe
Replaced edition
10.15

Fortsetzung Blatt 27
Continued page

E-Nr. E-No.	Für Unterklasse / For Subclass	Material No. / Material Nr.	Stichplatte Throat plate			Transporteur Feed dog	Presserfuß Presser foot	Transp. Fuß Feeding foot	Abdeckplatte / Cover plate	Nadelhalter / Needle holder	Nadelsystem / -dcke / Needle system / -size					
			①	⑦	⑥											
Abb.-Nr. Fig.No.	Verwendungszweck / Use		Stichplatte / Throat plate	Schieber, links / Side, left	Schieber, rechts / Side, right	Stichlochgröße / Stitch hole size mm	Sägeverzahn / Serrated, oblique mm	Kreuzverzahn / Cross toothed mm	Dachverzahn / Roof-shaped mm	Drückerfuß / Presser foot	Unverzahn / Non toothed	Hüpfertuß, kreuzverz. / Skipping f., cross toothed	Ausgleichfuß / Compensating foot	Kreuzverzahn / Cross toothed mm	Unverzahn / Non toothed	⑤
E111/0-6	-190125; -190145; -190425; -190445 Näheinrichtung, Nadelstärke Nm 110-140, Stichlänge max. 6 mm, für mittelschweres Nähgut; mit Kurzfadenabschneider. Sewing equipment, needle size Nm 110-140, stitch length max. 6 mm, for medium weight material; with short thread trimmer.	0867 E11106	0867 200580	0867 140410	0867 141113	2,2 x 3,2	0867 210050			0367 220993				0467 220013		134-35/120
E112/0-9	-190125; -190145; -190425; -190445 Näheinrichtung, Nadelstärke Nm 110-140, Stichlänge max. 9 mm, für mittelschweres Nähgut; mit Kurzfadenabschneider. Sewing equipment, needle size Nm 110-140, stitch length max. 9 mm, for medium weight material; with short thread trimmer.	0867 E11209	0867 200590	0867 140410	0867 141113	2,2 x 3,2	0867 210050			0467 220043				0467 220013		134-35/120
E121/0-6	-190125; -190145; -190425; -190445 Näheinrichtung, Nadelstärke Nm 130-160, Stichlänge max. 6 mm, für mittelschweres Nähgut; mit Kurzfadenabschneider. Sewing equipment, needle size Nm 130-160, stitch length max. 6 mm, for medium weight material; with short thread trimmer.	0867 E12106	0867 200580	0867 140410	0867 141113	3,0 x 3,7	0867 210090			0367 220993				0768 220113		134-35/150
E121/0-7	-190125; -190145; -190425; -190445 Näheinrichtung, Nadelstärke Nm 130-160, Stichlänge max. 7 mm, für mittelschweres Nähgut; mit Kurzfadenabschneider. Sewing equipment, needle size Nm 130-160, stitch length max. 7 mm, for medium weight material; with short thread trimmer.	0867 E12107	0867 200340	0867 140410	0867 141113	3,0 x 3,7	0867 210380			0867 220774				0867 220593		134-35/150
E122/0-9	-190125; -190145; -190425; -190445 Näheinrichtung, Nadelstärke Nm 130-160, Stichlänge max. 9 mm, für mittelschweres Nähgut; mit Kurzfadenabschneider. Sewing equipment, needle size Nm 130-160, stitch length max. 9 mm, for medium weight material; with short thread trimmer.	0867 E12209	0867 200590	0867 140410	0867 141113	3,0 x 3,7	0867 210090			0467 220043				0768 220113		134-35/150

☐ = Änderung / Modification



Näheinrichtungen 867- M Standard
Sewing equipment

Ausgabe
Edition
10.18
Ersetzt Ausgabe/
Replaced Edition
09.17

Blatt 27
Page

Fortsetzung Blatt 28
Continued page

E-Nr. E-No. Abb.-Nr. Fig.No.	Für Unterklasse / For Subclass Verwendungszweck / Use	Material No. / Material Nr.	Stichplatte Throat plate			Transporteur Feed dog				Presserfuß Presser foot		Transp. Fuß Feeding foot		Nadelhalter / Needle holder	Nadelsystem / -size	
			①	⑦	⑥	②	③	④	⑤	⑥	⑦	⑧				
E212/0-6	-190145; -190445 Näheinrichtung, Nadelstärke Nm 110-140, Stichlänge max. 6 mm, für mittelschweres Nähgut; mit Kurzfadensabschneider und Bausatz NSB. Sewing equipment, needle size Nm 110-140, stitch length max. 6 mm, for medium weight material; with short thread trimmer and NSB kit.	0867 E21206	0867 200790	0867 140620	0867 141113	2,2 x 3,2	0867 210770				0367 220993			0467 220013		134-35/120
E212/0-9	-190145; -190445 Näheinrichtung, Nadelstärke Nm 110-140, Stichlänge max. 9 mm, für mittelschweres Nähgut; mit Kurzfadensabschneider und Bausatz NSB. Sewing equipment, needle size Nm 110-140, stitch length max. 9 mm, for medium weight material; with short thread trimmer and NSB kit.	0867 E21209	0867 200780	0867 140620	0867 141113	2,2 x 3,2	0867 210770				0467 220043			0467 220013		134-35/120
E801/0-7	-160322 Näheinrichtung für Kedararbeiten, Kedernut 6,5 mm, Nadelstärke Nm 120-140. Stichlänge max. 7 mm, für mittelschweres Nähgut. Sewing equipment for welt attaching operations, welt groove 6,5 mm, needle size Nm 120-140. Stich length max. 7 mm, for medium weight material.	0867 E80107	0867 200990	0867 140960		∅ 2,5	0867 210990				0867 221304			0867 221324		134-35/130
E802/0-7	-160322 Näheinrichtung für Kedararbeiten, Kedernut 6,5 mm, Nadelstärke Nm 120-140. Stichlänge max. 7 mm, für mittelschweres Nähgut. Sewing equipment for welt attaching operations, welt groove 6,5 mm, needle size Nm 120-140. Stich length max. 7 mm, for medium weight material.	0867 E80207	0867 200990	0867 140960		∅ 2,5	0867 210990				0867 222334			0867 221324		134-35/130

☐ = Änderung / Modification



Näheinrichtungen 867- M Standard
Sewing equipment

Ausgabe
Edition
01.13

Blatt 28
Page

Fortsetzung Blatt 29
Continued page

E-Nr. E-No. Abb.-Nr. Fig.No.	Für Unterklasse / For Subclass Verwendungszweck / Use	Material No. / Material Nr.	Stichplatte Throat plate			Transporteur Feed dog			Presserfuß Presser foot		Transp. Fuß Feeding foot		Nadelhalter/ Needle holder	Nadelabstand / Needle distance	Nadelsystem / -dicke / Needle system / -size
			①	⑦	⑥	②	④	③	⑤						
E21/3-6	-260122; -260322; -290020; -290040; -290122; -290142; -290322; -290342 Näheinrichtung, Nadelabstand 3 mm, Nadelstärke Nm 110-140, Stichtlänge max. 6 mm, für mittelschweres Nähgut. Sewing equipment, needle gauge 3 mm, needle size Nm 110-140, stitch length max. 6 mm, for medium weight material.	0867 E02106 3	0867 200330	0867 140010	0867 140040	2,2 x 3,2	0867 210190		0868 222153			0868 222163	3	0867 230104	134-35/130
E21/3,2-6	-260122; -260322; -290020; -290040; -290122; -290142; -290322; -290342 Näheinrichtung, Nadelabstand 3,2 mm, Nadelstärke Nm 110-140. Stichtlänge max. 6 mm, für mittelschweres Nähgut. Sewing equipment, needle gauge 3,2 mm, needle size Nm 110-140. Sticht length max. 6 mm, for medium weight material.	0867 E02106 3 2	0867 200330	0867 140010	0867 140040	2,2 x 3,2	0867 210190		0868 222153			0868 222163	3,2	0867 230104	134-35/130

☐ = Änderung / Modification



Näheinrichtungen 867- M Standard Sewing equipment

Ausgabe
Edition
02.06

Blatt 29
Page

Fortsetzung Blatt 30
Continued page

E-Nr. E-No.	Für Unterklasse / For Subclass	Abb.-Nr. Fig.No.	Verwendungszweck / Use	Material No. / Material Nr.	Stichplatte	Transporteur	Presserfuß	Transp. Fuß	Nadelabstand / Needle distance	Nadelhalter / Needle holder	Nadelsystem / -dsize / Needle system / -size	
					Throat plate	Feed dog	Presser foot	Feeding foot				
					①	⑦	⑥	②	④	③	⑤	
E21/4	-290020; -290040; -290122; -290142; -290322; -290342 Näheinrichtung, Nadelabstand 4 mm, Nadelstärke Nm 110-140, Stichtlänge max. 6 mm, für mittelschweres Nähgut. Sewing equipment, needle gauge 4 mm, needle size Nm 110-140, stitch length max. 6 mm, for medium weight material.			0867 E02106 4	0867 200200	0867 140010	0867 140040		0367 222473	0067 222323	4	0867 230114 134-35/130
E21/5	-290020; -290040; -290122; -290142; -290322; -290342 Näheinrichtung, Nadelabstand 5 mm, Nadelstärke Nm 110-140, Stichtlänge max. 6 mm, für mittelschweres Nähgut. Sewing equipment, needle gauge 5 mm, needle size Nm 110-140, stitch length max. 6 mm, for medium weight material			0867 E02106 5	0867 200210	0867 140010	0867 140040		0367 222243	0067 222333	5	0867 230124 134-35/130
E21/6	-290020; -290040; -290122; -290142; -290322; -290342 Näheinrichtung, Nadelabstand 6 mm, Nadelstärke Nm 110-140, Stichtlänge max. 6 mm, für mittelschweres Nähgut. Sewing equipment, needle gauge 6 mm, needle size Nm 110-140, stitch length max. 6 mm, for medium weight material.			0867 E02106 6	0867 200220	0867 140010	0867 140040		0367 222093	0067 222343	6	0867 230134 134-35/130
E21/8	-290020; -290040; -290122; -290142; -290322; -290342 Näheinrichtung, Nadelabstand 8 mm, Nadelstärke Nm 110-140, Stichtlänge max. 6 mm, für mittelschweres Nähgut. Sewing equipment, needle gauge 8 mm, needle size Nm 110-140, stitch length max. 6 mm, for medium weight material.			0867 E02106 8	0867 200230	0867 140050	0867 140060		0367 222103	0067 222353	8	0867 230144 134-35/130
E21/10	-290020; -290040; -290122; -290142; -290322; -290342 Näheinrichtung, Nadelabstand 10 mm, Nadelstärke Nm 110-140, Stichtlänge max. 6 mm, für mittelschweres Nähgut. Sewing equipment, needle gauge 10 mm, needle size Nm 110-140, stitch length max. 6 mm, for medium weight material.			0867 E02106 10	0867 200240	0867 140050	0867 140060		0367 222013	0067 222383	10	0867 230154 134-35/130

☐ = Änderung / Modification



Näheinrichtungen 867- M Standard Sewing equipment

Ausgabe
Edition
02.06

Blatt 30
Page

Fortsetzung Blatt 31
Continued page

E-Nr. E-No.	Für Unterklasse / For Subclass	Abb.-Nr. Fig.No.	Verwendungszweck / Use	Material No. / Material Nr.	Stichplatte	Transporteur	Presserfuß	Transp. Fuß												
					Throat plate	Feed dog	Presser foot	Feeding foot												
					①	⑦	⑥													
E21/12	-290020; -290040; -290122; -290142; -290322; -290342 Näheinrichtung, Nadelabstand 12 mm, Nadelstärke Nm 110-140, Stichlänge max. 6 mm, für mittelschweres Nähgut. Sewing equipment, needle gauge 12 mm, needle size Nm 110-140, stitch length max. 6 mm, for medium weight material.			0867 E02106 12	0867 200250	0867 140070	0867 140080	2,2 x 3,2	0867 210250					0367 222313			0067 222393	12	0867 230164	134-35/130
E21/14	-290020; -290040; -290122; -290142; -290322; -290342 Näheinrichtung, Nadelabstand 14 mm, Nadelstärke Nm 110-140, Stichlänge max. 6 mm, für mittelschweres Nähgut. Sewing equipment, needle gauge 14 mm, needle size Nm 110-140, stitch length max. 6 mm, for medium weight material.			0867 E02106 14	0867 200260	0867 140070	0867 140080	2,2 x 3,2	0867 210260					0367 222323			0067 222413	14	0867 230174	134-35/130
E21/16	-290020; -290040; -290122; -290142; -290322; -290342 Näheinrichtung, Nadelabstand 16 mm, Nadelstärke Nm 110-140, Stichlänge max. 6 mm, für mittelschweres Nähgut. Sewing equipment, needle gauge 16 mm, needle size Nm 110-140, stitch length max. 6 mm, for medium weight material.			0867 E02106 16	0867 200270	0867 140090	0867 140100	2,2 x 3,2	0867 210270					0367 222333			0067 222423	16	0867 230184	134-35/130
E21/18	-290020; -290040; -290122; -290142; -290322; -290342 Näheinrichtung, Nadelabstand 18 mm, Nadelstärke Nm 110-140, Stichlänge max. 6 mm, für mittelschweres Nähgut. Sewing equipment, needle gauge 18 mm, needle size Nm 110-140, stitch length max. 6 mm, for medium weight material.			0867 E02106 18	0867 200280	0867 140090	0867 140100	2,2 x 3,2	0867 210280					0367 222533			0067 222433	18	0867 230194	134-35/130
E21/20	-290020; -290040; -290122; -290142; -290322; -290342 Näheinrichtung, Nadelabstand 20 mm, Nadelstärke Nm 110-140, Stichlänge max. 6 mm, für mittelschweres Nähgut. Sewing equipment, needle gauge 20 mm, needle size Nm 110-140, stitch length max. 6 mm, for medium weight material.			0867 E02106 20	0867 200290	0867 140110	0867 140120	2,2 x 3,2	0867 210290					0367 222543			0067 222443	20	0867 230204	134-35/130

□ = Änderung / Modification



Näheinrichtungen 867- M Standard

Ausgabe
Edition
09.10

Blatt 31
Page

Ersetzt Ausgabe
Replaced edition
02.06

Fortsetzung Blatt 32
Continued page

E-Nr. E-No.	Für Unterklasse / For Subclass	Abb.-Nr. Fig.No.	Verwendungszweck / Use	Material No. / Material Nr.	Stichplatte Throat plate			Transporteur Feed dog			Presserfuß Presser foot		Transp. Fuß Feeding foot	Nadelhalter / Needle holder	Nadelstärken / Needle sizes	
					①	⑦	⑥	②	③	④	⑤					
E21/22	-290020; -290040; -290122; -290142; -290322; -290342 Näheinrichtung, Nadelabstand 22 mm, Nadelstärke Nm 110-140, Stichtlänge max. 6 mm, für mittelschweres Nähgut. Sewing equipment, needle gauge 22 mm, needle size Nm 110-140, stitch length max. 6 mm, for medium weight material.			0867 E02106 22	0867 200300	0867 140110	0867 140120	2,2 x 3,2	0867 210300		0367 222413		0067 222773	22	0867 230214	134-35/130
E21/50	-290020; -290040; -290122; -290142; -290322; -290342 Näheinrichtung, Nadelabstand 50 mm, Nadelstärke Nm 110-140, Stichtlänge max. 6 mm, für mittelschweres Nähgut. Sewing equipment, needle gauge 50 mm, needle size Nm 110-140, stitch length max. 6 mm, for medium weight material.			0867 E02106 50	0867 200310	0867 140130	0867 140140	2,2 x 3,2	0867 210310		0867 220403		0867 220413	50	0867 230304	134-35/130
E22/6/9	-290020; -290040; -290122; -290142; -290322; -290342 Näheinrichtung zum Aussteppen von Schließnähten, Nadelabstand 6 mm, Nadelstärke Nm 110-140, Stichtlänge max. 9 mm, für mittelschweres Nähgut. Sewing equipment for topstitching of closing seams, needle gauge 6 mm, needle size Nm 110-140, stitch length max. 9 mm, for medium weight material.			0867 E02209 6	0867 200400	0867 140010	0867 140040	2,2 x 3,2	0867 210220		0768 222123		0768 222264	6	0867 230134	134-35/130
E22/8/6	-290020; -290040; -290122; -290142; -290322; -290342 Näheinrichtung zum Aussteppen von Schließnähten, Nadelabstand 8 mm, Nadelstärke Nm 110-140, Stichtlänge max. 6 mm, für mittelschweres Nähgut. Sewing equipment for topstitching of closing seams, needle gauge 8 mm, needle size Nm 110-140, stitch length max. 6 mm, for medium weight material.			0867 E02206 8	0867 200230	0867 140050	0867 140060	2,2 x 3,2	0867 210230		0768 222133		0768 222274	8	0867 230144	134-35/130
E22/8/9	-290020; -290040; -290122; -290142; -290322; -290342 Näheinrichtung zum Aussteppen von Schließnähten, Nadelabstand 8 mm, Nadelstärke Nm 110-140, Stichtlänge max. 9 mm, für mittelschweres Nähgut. Sewing equipment for topstitching of closing seams, needle gauge 8 mm, needle size Nm 110-140, stitch length max. 9 mm, for medium weight material.			0867 E02209 8	0867 200410	0867 140050	0867 140060	2,2 x 3,2	0867 210230		0768 222133		0768 222274	8	0867 230144	134-35/130

☐ = Änderung / Modification



Näheinrichtungen 867- M Standard

Ausgabe
Edition
05.06
Ersetzt Ausgabe
Replaced edition
02.06

Blatt 32
Page

Fortsetzung Blatt 33
Continued page

E-Nr. E-No. Abb.-Nr. Fig.No.	Für Unterklasse / For Subclass Verwendungszweck / Use	Material No. / Material Nr.	Stichplatte Throat plate			Transporteur Feed dog			Presserfuß Presser foot		Transp. Fuß Feeding foot					
			①	⑦	⑥							⑤				
E22/10/6	-290020; -290040; -290122; -290142; -290322; -290342 Näheinrichtung zum Aussteppen von Schließnähten, Nadelabstand 10 mm, Nadelstärke Nm 110-140, Stichtlänge max. 6 mm, für mittelschweres Nähgut. Sewing equipment for topstitching of closing seams, needle gauge 10 mm, needle size Nm 110-140, stitch length max. 6 mm, for medium weight material.	0867 E02206 10	0867 200240	0867 140050	0867 140060	2,2 x 3,2	0867 210240			0768 222143		0768 222284		10	0867 230154	134-35/130
E22/10/9	-290020; -290040; -290122; -290142; -290322; -290342 Näheinrichtung zum Aussteppen von Schließnähten, Nadelabstand 10 mm, Nadelstärke Nm 140-180, Stichtlänge max. 9 mm, für mittelschweres Nähgut. Sewing equipment for topstitching of closing seams, needle gauge 10 mm, needle size Nm 140-180, stitch length max. 9 mm, for medium weight material.	0867 E02209 10	0867 200420	0867 140050	0867 140060	2,8 x 3,7	0867 210450			0768 222143		0768 222404		10	0867 230154	134-35/160
E22/10/12	-290020; -290040; -290122; -290142; -290322; -290342 Näheinrichtung zum Aussteppen von Schließnähten, Nadelabstand 10 mm, Nadelstärke Nm 140-180, Stichtlänge max. 12 mm, für mittelschweres Nähgut. Sewing equipment for topstitching of closing seams, needle gauge 10 mm, needle size Nm 140-180, stitch length max. 12 mm, for medium weight material.	0867 E02212 10	0867 200450	0867 140050	0867 140060	2,8 x 3,7	0867 210450			0768 222143		0768 222404		10	0867 230154	134-35/160
E22/12/9	-290020; -290040; -290122; -290142; -290322; -290342 Näheinrichtung zum Aussteppen von Schließnähten, Nadelabstand 12 mm, Nadelstärke Nm 140-180, Stichtlänge max. 9 mm, für mittelschweres Nähgut. Sewing equipment for topstitching of closing seams, needle gauge 12 mm, needle size Nm 140-180, stitch length max. 9 mm, for medium weight material.	0867 E02209 12	0867 200430	0867 140070	0867 140080	2,8 x 3,7	0867 210460			0768 222153		0768 222434		12	0867 230164	134-35/160

☐ = Änderung / Modification



Näheinrichtungen 867- M Standard

Sewing equipment

Ausgabe
Edition
01.07

Blatt 33
Page

Ersetzt Ausgabe
Replaced edition
08.06

Fortsetzung Blatt 34
Continued page

E-Nr. E-No.	Für Unterklasse / For Subclass	Abb.-Nr. Fig.No.	Verwendungszweck / Use	Material No. / Material Nr.	Stichplatte Throat plate		Transporteur Feed dog		Presserfuß Presser foot		Transp. Fuß Feeding foot					
					①	⑦	⑥	②	④	③						
E22/12/12	-290020; -290040; -290122; -290142; -290322; -290342 Näheinrichtung zum Aussteppen von Schließnähten, Nadelabstand 12 mm, Nadelstärke Nm 140-180, Stichtlänge max. 12 mm, für mittelschweres Nähgut. Sewing equipment for topstitching of closing seams, needle gauge 12 mm, needle size Nm 140-180, stitch length max. 12 mm, for medium weight material.			0867 E02212 12	0867 200460	0867 140070	0867 140080	2,8 x 3,7	0867 210460	0768 222153		0768 222434	12	0867 230164	134-35/160	
E22/14/12	-290020; -290040; -290122; -290142; -290322; -290342 Näheinrichtung zum Aussteppen von Schließnähten, Nadelabstand 14 mm, Nadelstärke Nm 140-180, Stichtlänge max. 12 mm, für mittelschweres Nähgut. Sewing equipment for topstitching of closing seams, needle gauge 14 mm, needle size Nm 140-180, stitch length max. 12 mm, for medium weight material.			0867 E02212 14	0867 200470	0867 140070	0867 140080	2,8 x 3,7	0867 210470	0867 222163		0768 222464	14	0867 230174	134-35/160	
E23/10	-290020; -290040; -290122; -290142; -290322; -290342 Näheinrichtung zum Einnähen von Reißverschlüssen, Nadelabstand 10 mm, Nadelstärke Nm 110-140, Stichtlänge max. 6 mm, für mittelschweres Nähgut. Sewing equipment for inserting zippers, needle gauge 10 mm, needle size Nm 110-140, stitch length max. 6 mm, for medium weight material.			0867 E02306 10	0867 200950	0867 140050	0867 140060	∅ 1,7	0867 210950	0367 222513			0067 224103	10	0867 230154	134-35/130
E23/12	-290020; -290040; -290122; -290142; -290322; -290342 Näheinrichtung zum Einnähen von Reißverschlüssen, Nadelabstand 12 mm, Nadelstärke Nm 110-140, Stichtlänge max. 6 mm, für mittelschweres Nähgut. Sewing equipment for inserting zippers, needle gauge 12 mm, needle size Nm 110-140, stitch length max. 6 mm, for medium weight material.			0867 E02306 12	0867 200960	0867 140070	0867 140080	∅ 2	0867 210960	0367 222373			0067 223223	12	0867 230164	134-35/130

□ = Änderung / Modification



Näheinrichtungen 867- M Standard Sewing equipment

Ausgabe
Edition
01.07
Ersetzt Ausgabe
Replaced edition
02.06

Blatt 34
Page

Fortsetzung Blatt 35
Continued page

E.-Nr. E-No.	Für Unterklasse / For Subclass	Abb.-Nr. Fig.No.	Verwendungszweck / Use	Stichplatte		Transporteur	Presserfuß	Transp. Fuß			
				Throat plate	Feed dog				Presser foot	Feeding foot	
				①	⑦	⑥	②	④	③	⑤	
E24/6/9	-290122; -290142; -290322; -290342 Näheinrichtung zum Aussteppen von Schließnähten, Nadelabstand 6 mm, Nadelstärke Nm 110-140, Stichlänge max. 9 mm, für mittelschweres Nähgut. Sewing equipment for topstitching of closing seams, needle gauge 6 mm, needle size Nm 110-140, stitch length max. 9 mm, for medium weight material.	0867 E02409 6	0867 E02409 6 0867 200400 0867 140010 0867 140040 2,2 x 3,2 0867 210220	0867 200400 0867 140050 0867 140060 0867 140060 2,2 x 3,2 0867 210230	0867 200410 0867 140050 0867 140060 0867 140060 2,2 x 3,2 0867 210230	0867 200410 0867 140050 0867 140060 0867 140060 2,2 x 3,2 0867 210230	0768 222664 0768 222674 0768 222684 0768 222694	0768 222264 0768 222274 0768 222284 0768 222294	6 8 10 12	0867 230134 0867 230144 0867 230154 0867 230164	134-35/130 134-35/130 134-35/130 134-35/130
E24/8/9	-290122; -290142; -290322; -290342 Näheinrichtung zum Aussteppen von Schließnähten, Nadelabstand 8 mm, Nadelstärke Nm 110-140, Stichlänge max. 9 mm, für mittelschweres Nähgut. Sewing equipment for topstitching of closing seams, needle gauge 8 mm, needle size Nm 110-140, stitch length max. 9 mm, for medium weight material.	0867 E02409 8	0867 E02409 8 0867 200410 0867 140050 0867 140060 2,2 x 3,2 0867 210230	0867 200410 0867 140050 0867 140060 0867 140060 2,2 x 3,2 0867 210230	0867 200410 0867 140050 0867 140060 0867 140060 2,2 x 3,2 0867 210230	0867 200410 0867 140050 0867 140060 0867 140060 2,2 x 3,2 0867 210230	0768 222674 0768 222684 0768 222694	0768 222274 0768 222284 0768 222294	8 10 12	0867 230144 0867 230154 0867 230164	134-35/130 134-35/130 134-35/130
E24/10/9	-290122; -290142; -290322; -290342 Näheinrichtung zum Aussteppen von Schließnähten, Nadelabstand 10 mm, Nadelstärke Nm 110-140, Stichlänge max. 9 mm, für mittelschweres Nähgut. Sewing equipment for topstitching of closing seams, needle gauge 10 mm, needle size Nm 110-140, stitch length max. 9 mm, for medium weight material.	0867 E02409 10	0867 E02409 10 0867 200420 0867 140050 0867 140060 2,2 x 3,2 0867 210240	0867 200420 0867 140050 0867 140060 0867 140060 2,2 x 3,2 0867 210240	0867 200420 0867 140050 0867 140060 0867 140060 2,2 x 3,2 0867 210240	0867 200420 0867 140050 0867 140060 0867 140060 2,2 x 3,2 0867 210240	0768 222684 0768 222694	0768 222284 0768 222294	10 12	0867 230154 0867 230164	134-35/130 134-35/130
E24/12/9	-290122; -290142; -290322; -290342 Näheinrichtung zum Aussteppen von Schließnähten, Nadelabstand 12 mm, Nadelstärke Nm 110-140, Stichlänge max. 9 mm, für mittelschweres Nähgut. Sewing equipment for topstitching of closing seams, needle gauge 12 mm, needle size Nm 110-140, stitch length max. 9 mm, for medium weight material.	0867 E02409 12	0867 E02409 12 0867 200430 0867 140070 0867 140080 2,2 x 3,2 0867 210250	0867 200430 0867 140070 0867 140080 0867 140080 2,2 x 3,2 0867 210250	0867 200430 0867 140070 0867 140080 0867 140080 2,2 x 3,2 0867 210250	0867 200430 0867 140070 0867 140080 0867 140080 2,2 x 3,2 0867 210250	0768 222694 0768 222694	0768 222294 0768 222294	12	0867 230164	134-35/130

☐ = Änderung / Modification



Näheinrichtungen 867- M Standard

Sewing equipment

Ausgabe
Edition
08.06

Blatt 35
Page

Ersetzt Ausgabe
Replaced edition
05.06

Fortsetzung Blatt 36
Continued page

E-Nr. E-No.	Für Unterklasse / For Subclass	Abb.-Nr. Fig.No.	Verwendungszweck / Use	Material No. / Material Nr.	Stichplatte Throat plate			Transporteur Feed dog	Presserfuß Presser foot	Transp. Fuß Feeding foot				
					①	⑦	⑥							
E24/8/12	-290122; -290142; -290322; -290342 Näheinrichtung zum Aussteppen von Schließnähten, Nadelabstand 8 mm, Nadelstärke Nm 140-180, Stichtlänge max. 12 mm, für mittelschweres Nähgut. Sewing equipment for topstitching of closing seams, needle gauge 8 mm, needle size Nm 140-180, stitch length max. 12 mm, for medium weight material.			0867 E02412 8	0867 200440	0867 140050	0867 140060	2,8 x 3,7	0867 210440	0867 220054	0768 222374	8	0867 230144	134-35/160
E24/10/12	-290122; -290142; -290322; -290342 Näheinrichtung zum Aussteppen von Schließnähten, Nadelabstand 10 mm, Nadelstärke Nm 140-180, Stichtlänge max. 12 mm, für mittelschweres Nähgut. Sewing equipment for topstitching of closing seams, needle gauge 10 mm, needle size Nm 140-180, stitch length max. 12 mm, for medium weight material.			0867 E02412 10	0867 200450	0867 140050	0867 140060	2,8 x 3,7	0867 210450	0867 220064	0768 222404	10	0867 230154	134-35/160
E24/12/12	-290122; -290142; -290322; -290342 Näheinrichtung zum Aussteppen von Schließnähten, Nadelabstand 12 mm, Nadelstärke Nm 140-180, Stichtlänge max. 12 mm, für mittelschweres Nähgut. Sewing equipment for topstitching of closing seams, needle gauge 12 mm, needle size Nm 140-180, stitch length max. 12 mm, for medium weight material.			0867 E02412 12	0867 200460	0867 140070	0867 140080	2,8 x 3,7	0867 210460	0867 220074	0768 222434	12	0867 230164	134-35/160
E24/14/12	-290122; -290142; -290322; -290342 Näheinrichtung zum Aussteppen von Schließnähten, Nadelabstand 14 mm, Nadelstärke Nm 140-180, Stichtlänge max. 12 mm, für mittelschweres Nähgut. Sewing equipment for topstitching of closing seams, needle gauge 14 mm, needle size Nm 140-180, stitch length max. 12 mm, for medium weight material.			0867 E02412 14	0867 200470	0867 140070	0867 140080	2,8 x 3,7	0867 210470	0867 220084	0768 222464	14	0867 230174	134-35/160

☐ = Änderung / Modification



Näheinrichtungen 867- M Standard

Sewing equipment

Ausgabe
Edition
08.18

Blatt 36
Page

Ersetzt Ausgabe
Replaced edition
01.07

Fortsetzung Blatt 37
Continued page

E-Nr. E-No. Abb.-Nr. Fig.No.	Für Unterklasse / For Subclass Verwendungszweck / Use	Material No. / Material Nr.	Stichplatte Throat plate			Transporteur Feed dog	Presserfuß Presser foot	Transp. Fuß Feeding foot
			①	⑦	⑥			
E51/6/9	-290020; -290040; -290122; -290142; -290322; -290342 Näheinrichtung asymmetrisch für allgemeine Näharbeiten. Die rechte Nadel befindet sich auf der Mitte der Nadelstange, um die Maschine auch als Einnadelmaschine einsetzen zu können. Nadelabstand 6 mm, Nadelstärke Nm 110-140, Stichtlänge max. 9 mm, für mittelschweres Nähgut. Sewing equipment asymmetric for general sewing operations. The right needle is located on the needle bar center so that the machine could be also used as a single needle one. Needle gauge 6 mm, needle size Nm 110-140, stitch length max. 9 mm, for medium weight material.	0867 E05109 6	0867 V91678	0867 140070	0867 140020	2,2 x 3,2	0867 V91679	0467 V90522
E51/8/9	-290020; -290040; -290122; -290142; -290322; -290342 Näheinrichtung asymmetrisch für allgemeine Näharbeiten. Die rechte Nadel befindet sich auf der Mitte der Nadelstange, um die Maschine auch als Einnadelmaschine einsetzen zu können. Nadelabstand 8 mm, Nadelstärke Nm 110-140, Stichtlänge max. 9 mm, für mittelschweres Nähgut. Sewing equipment asymmetric for general sewing operations. The right needle is located on the needle bar center so that the machine could be also used as a single needle one. Needle gauge 8 mm, needle size Nm 110-140, stitch length max. 9 mm, for medium weight material.	0867 E05109 8	0867 200500	0867 140090	0867 140020	2,2 x 3,2	0867 210500	0867 220033
E51/10/9	-290020; -290040; -290122; -290142; -290322; -290342 Näheinrichtung asymmetrisch für allgemeine Näharbeiten. Die rechte Nadel befindet sich auf der Mitte der Nadelstange, um die Maschine auch als Einnadelmaschine einsetzen zu können. Nadelabstand 10 mm, Nadelstärke Nm 110-140, Stichtlänge max. 9 mm, für mittelschweres Nähgut. Sewing equipment asymmetric for general sewing operations. The right needle is located on the needle bar center so that the machine could be also used as a single needle one. Needle gauge 10 mm, needle size Nm 110-140, stitch length max. 9 mm, for medium weight material.	0867 E05109 10	0867 200510	0867 140110	0867 140020	2,2 x 3,2	0867 210510	0467 222123

☐ = Änderung / Modification



Näheinrichtungen 867- M Standard
Sewing equipment

Ausgabe
Edition
09.17

Blatt 37
Page

Ersetzt Ausgabe
Replaced edition
05.11

Fortsetzung Blatt 38
Continued page

E-Nr. E-No. Abb.-Nr. Fig.No.	Für Unterklasse / For Subclass Verwendungszweck / Use	Material No. / Material Nr.	Stichplatte	Transporteur	Presserfuß	Transp. Fuß							
			Throat plate	Feed dog	Presser foot	Feeding foot							
			①	⑦	⑥		②	④	③	⑤			
E51/12/9	-290020; -290040; -290122; -290142; -290322; -290342 Näheinrichtung asymmetrisch für allgemeine Näharbeiten. Die rechte Nadel befindet sich auf der Mitte der Nadelstange, um die Maschine auch als Einnadelmaschine einsetzen zu können. Nadelabstand 12 mm, Nadelstärke Nm 110-140, Stichtlänge max. 9 mm, für mittelschweres Nähgut. Sewing equipment asymmetric for general sewing operations. The right needle is located on the needle bar center so that the machine could be also used as a single needle one. Needle gauge 12 mm, needle size Nm 110-140, stitch length max. 9 mm, for medium weight material.	0867 E05109 12	0867 200520	0867 140170	0867 140020	2,2 x 3,2	0867 210520	0467 222183		0467 222173	12	0867 230034	134-35/130
E51/14/9	-290020; -290040; -290122; -290142; -290322; -290342 Näheinrichtung asymmetrisch für allgemeine Näharbeiten. Die rechte Nadel befindet sich auf der Mitte der Nadelstange, um die Maschine auch als Einnadelmaschine einsetzen zu können. Nadelabstand 14 mm, Nadelstärke Nm 110-140, Stichtlänge max. 9 mm, für mittelschweres Nähgut. Sewing equipment asymmetric for general sewing operations. The right needle is located on the needle bar center so that the machine could be also used as a single needle one. Needle gauge 14 mm, needle size Nm 110-140, stitch length max. 9 mm, for medium weight material.	0867 E05109 14	0867 200530	0867 140190	0867 140020	2,2 x 3,2	0867 210530	0467 222143		0467 222133	14	0867 230044	134-35/130

☐ = Änderung / Modification



Näheinrichtungen 867- M Standard

Sewing equipment

Ausgabe
Edition
09.17

Blatt 39
Page

Ersetzt Ausgabe
Replaced edition
01.15

Fortsetzung Blatt 40
Continued page

E-Nr. E-No.	Für Unterklasse / For Subclass	Material No. / Material Nr.	Stichplatte Throat plate			Transporteur Feed dog	Presserfuß Presser foot	Transp. Fuß Feeding foot	Abb.-Nr. Fig.No.	Verwendungszweck / Use		
			①	⑦	⑥							
E 121/6/6	-290445 Näheinrichtung, Nadelabstand 6 mm, Nadelstärke Nm 110-140, Stichlänge max. 6 mm, für mittelschweres Nähgut; mit Kurzfadenabschneider. Sewing equipment, needle gauge 6 mm, needle size Nm 110-140, stitch length max. 6 mm, for medium weight material; with short thread trimmer	0867 E12106 6	0867 200620	0867 140153	0867 140303	2,2 x 3,2	0867 210620	0367 222093	0067 222343	6	0867 230134	134-35/130
E 121/8/6	-290445 Näheinrichtung, Nadelabstand 8 mm, Nadelstärke Nm 110-140, Stichlänge max. 6 mm, für mittelschweres Nähgut; mit Kurzfadenabschneider. Sewing equipment, needle gauge 8 mm, needle size Nm 110-140, stitch length max. 6 mm, for medium weight material; with short thread trimmer	0867 E12106 8	0867 200630	0867 140313	0867 140323	2,2 x 3,2	0867 210630	0367 222103	0067 222353	8	0867 230144	134-35/130
E 121/8/7	-290445 Näheinrichtung, Nadelabstand 8 mm, Nadelstärke Nm 110-140, Stichlänge max. 7 mm, für mittelschweres Nähgut; mit Kurzfadenabschneider. Sewing equipment, needle gauge 8 mm, needle size Nm 110-140, stitch length max. 7 mm, for medium weight material; with short thread trimmer	0867 E12107 8	0867 200350	0867 141123	0867 141133	2,2 x 3,2	0867 210350	0367 222103	0067 222353	8	0867 230144	134-35/130
E 121/10/6	-290445 Näheinrichtung, Nadelabstand 10 mm, Nadelstärke Nm 110-140, Stichlänge max. 6 mm, für mittelschweres Nähgut; mit Kurzfadenabschneider. Sewing equipment, needle gauge 10 mm, needle size Nm 110-140, stitch length max. 6 mm, for medium weight material; with short thread trimmer	0867 E12106 10	0867 200640	0867 140313	0867 140323	2,2 x 3,2	0867 210640	0367 222013	0067 222383	10	0867 230154	134-35/130
E 121/12/6	-290445 Näheinrichtung, Nadelabstand 12 mm, Nadelstärke Nm 110-140, Stichlänge max. 6 mm, für mittelschweres Nähgut; mit Kurzfadenabschneider. Sewing equipment, needle gauge 12 mm, needle size Nm 110-140, stitch length max. 6 mm, for medium weight material; with short thread trimmer	0867 E12106 12	0867 200650	0867 140333	0867 140343	2,2 x 3,2	0867 210650	0367 222313	0067 222393	12	0867 230164	134-35/130

= Änderung / Modification



Näheinrichtungen 867- M Standard
Sewing equipment

Ausgabe
Edition
10.07

Blatt 40
Page

Fortsetzung Blatt
Continued page

E-Nr. E-No.	Für Unterklasse / For Subclass	Abb.-Nr. Fig.No.	Verwendungszweck / Use	Material No. / Material Nr.	Stichplatte	Transporteur	Presserfuß	Transp. Fuß	Nadelabstand/Needle distance	Nadelhalter/ Needle holder	Nadelsystem/-dicke / Needle system/-size							
				①	②	③	④	⑤				⑥	⑦	⑧				
				Stichplatte / Throat plate	Schieber, links / Side, left	Schieber, rechts / Side, right	Stichlochgröße / Stitch hole size	Sägeverzahn / Serrated	Kreuzverzahn / Cross toothed	Dachverzahn / Roof-shaped	Drückfuß / Presser foot	Unverzahn / Non toothed	Hüpffuß, kreuzverz. / Skipping f., cross toothed	Ausgleichfuß / Compensating foot	Kreuzverzahn / Cross toothed	Unverzahn / Non toothed		
E122/6/9	-290445 Näheinrichtung zum Aussteppen von Schließnähten, Nadelabstand 6 mm, Nadelstärke Nm 110-140, Stichtlänge max. 9 mm, für mittelschweres Nähgut; mit Kurzfadenabschneider. Sewing equipment for topstitching of closing seams, needle gauge 6 mm, needle size Nm 110-140, stitch length max. 9 mm, for medium weight material; with short thread trimmer			0867 E12209 6	0867 200800	0867 140153	0867 140303	2,2 x 3,2	0867 210620		0768 222123			0768 222264		6	0867 230134	134-35/130
E122/8/9	-290445 Näheinrichtung zum Aussteppen von Schließnähten, Nadelabstand 8 mm, Nadelstärke Nm 110-140, Stichtlänge max. 9 mm, für mittelschweres Nähgut; mit Kurzfadenabschneider. Sewing equipment for topstitching of closing seams, needle gauge 8 mm, needle size Nm 110-140, stitch length max. 9 mm, for medium weight material; with short thread trimmer			0867 E12209 8	0867 200810	0867 140313	0867 140323	2,2 x 3,2	0867 210630		0768 222133			0768 222274		8	0867 230144	134-35/130
E122/10/9	-290445 Näheinrichtung zum Aussteppen von Schließnähten, Nadelabstand 10 mm, Nadelstärke Nm 140-180, Stichtlänge max. 9 mm, für mittelschweres Nähgut; mit Kurzfadenabschneider. Sewing equipment for topstitching of closing seams, needle gauge 10 mm, needle size Nm 140-180, stitch length max. 9 mm, for medium weight material; with short thread trimmer			0867 E12209 10	0867 200820	0867 140313	0867 140323	2,2 x 3,2	0867 210640		0768 222143			0768 222404		10	0367 230154	134-35/130
E122/12/9	-290445 Näheinrichtung zum Aussteppen von Schließnähten, Nadelabstand 12 mm, Nadelstärke Nm 140-180, Stichtlänge max. 9 mm, für mittelschweres Nähgut; mit Kurzfadenabschneider. Sewing equipment for topstitching of closing seams, needle gauge 12 mm, needle size Nm 140-180, stitch length max. 9 mm, for medium weight material; with short thread trimmer			0867 E12209 12	0867 200830	0867 140333	0867 140343	2,2 x 3,2	0867 210650		0768 222153			0768 222434		12	0867 230164	134-35/130

☐ = Änderung / Modification

9770 867001

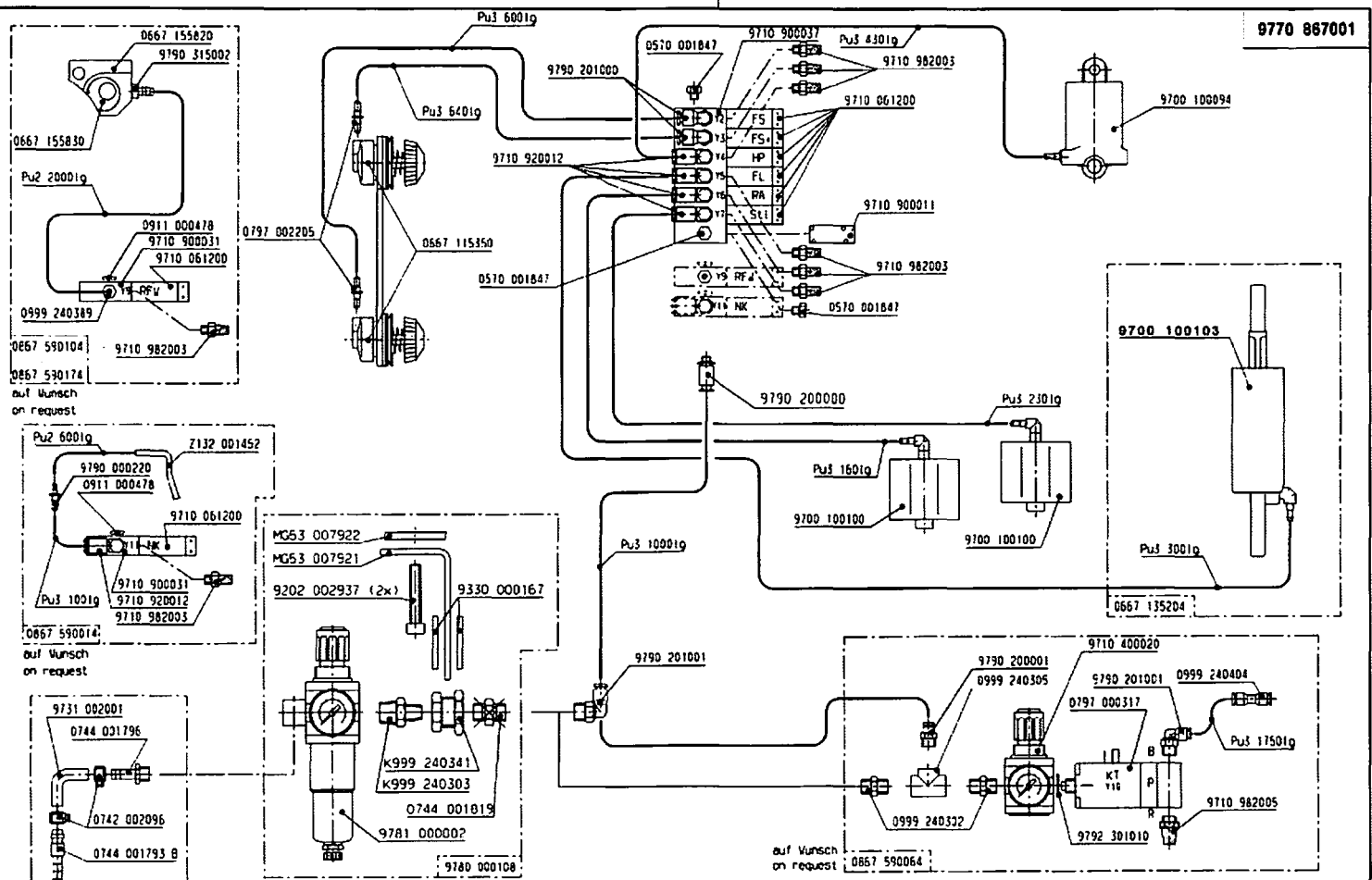

Schlauch	Teile-Nr. (Motorware)
Hose	Part-No. (Yarded goods)
PU2	0889 979265
PU3	9731 005004

Änd.	Datum	gez.	gepr.
04.0	11.01.10	Pasek P.	Ondroušek
08.0	27.10.09	Schubert	Schubert
02.0	30.01.08	Schubert	Schubert
01.0	31.10.07	Schubert	Langrock

Datum 26.10.00
 Pneu.-Geräteplan für
 Pneu.-Elements-Plan für
 0867-1903..

DÜRKOPP ADLER AG
9770 867001
 Blatt 1 Blatt. 7

B. Schürmann
 12.11.115
 83

9770 867001

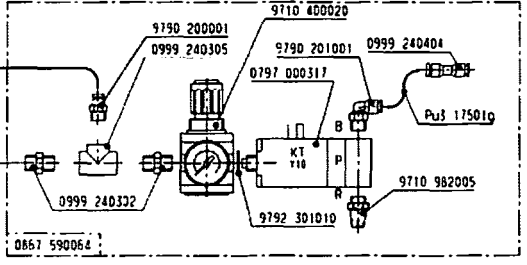
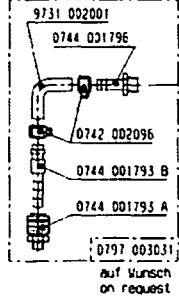
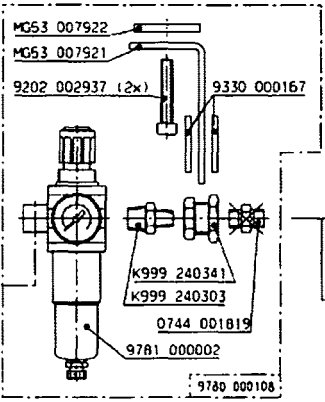
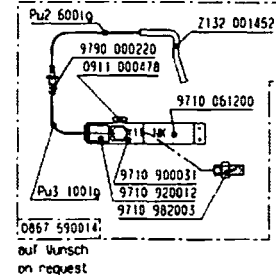
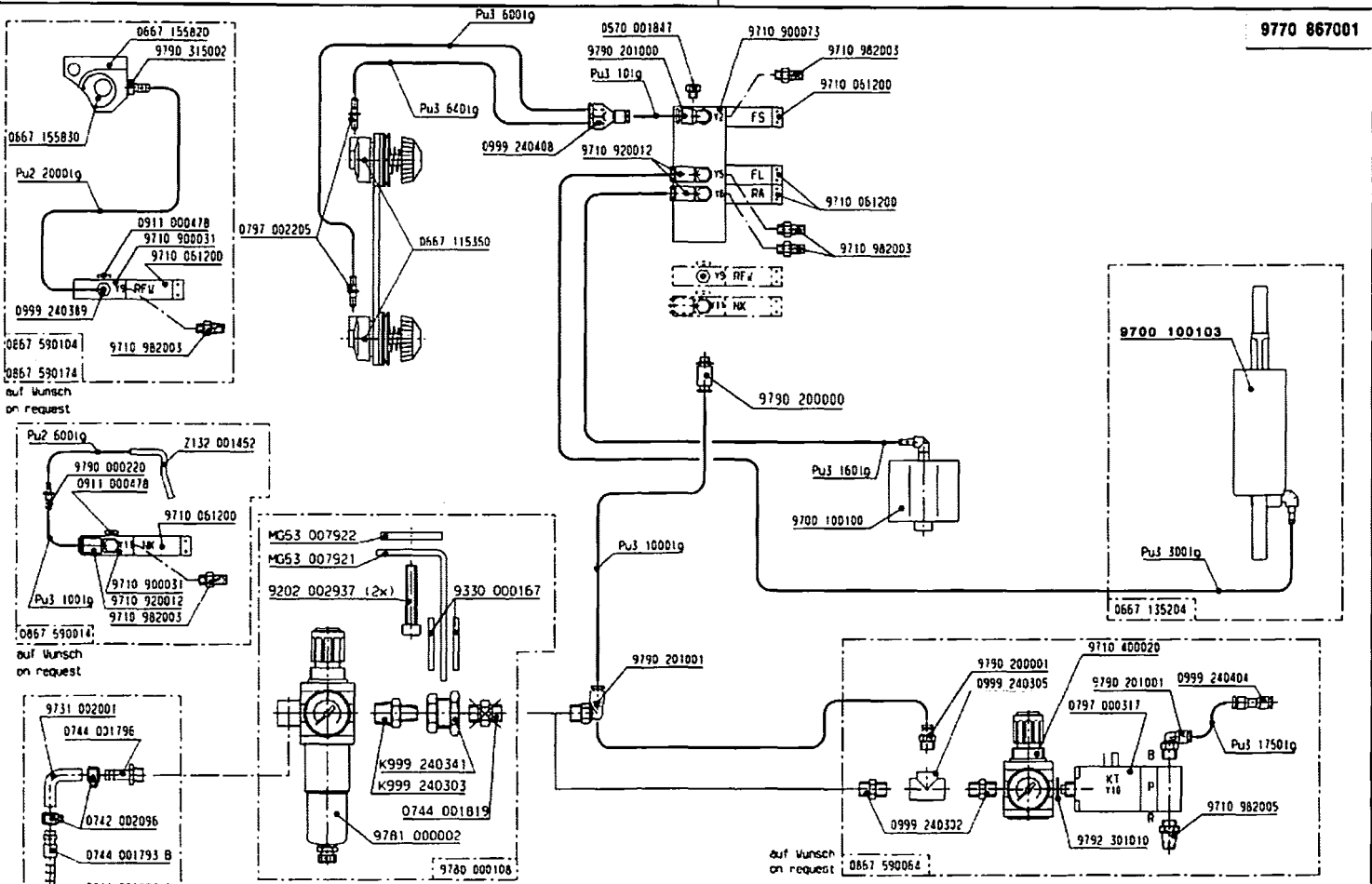

Schlauch	Teile-Nr. (Meterware)	Hose	Part-No. (Yarded goods)	PU2	0899 979265	PU3	9731 005004			
04.0	11.01.10	Paset P.	Ondrousch	Datum	28.10.00	gez.	Langreck	gez.	Langreck	gez.
03.0	27.10.09	Schbert	Schubert							
02.0	29.01.08	Scheld	Schubert							
01.0	31.10.07	Scheld	Langreck							
And.	Datum	gez.	gepr.							

Pneu.-Geräteplan für
Pneu.-Elements-Plan for
0867-190122
0867-190142

DÜRKOPP ADLER AG
9770 867001
Blatt 3 Blattz. 7



DÜRKOPP ADLER AG

Potsdamer Straße 190
33719 Bielefeld
GERMANY

Phone +49 (0) 521 / 925-00

E-Mail service@duerkopp-adler.com

www.duerkopp-adler.com

Subject to design changes – Parts List – Printed in Germany © Dürkopp Adler AG – 0791 867821 M – 06.0 – 11/2018