

For the professional user

Operating Instructions

Für den professionellen Anwender

Betriebsanleitung

Class: Efka DC
Klasse: DC1500/ST220A

Model:
Ausführung:

Machine number:
Maschinen-Nr.:

Dated:
Stand:

The sign of quality



You find the Strobel trademark on every Strobel machine leaving our works. And with good reason. This symbol is a guarantee of the high quality of our products. Quality which creates trust – trust in our technology, our service and, not least of all, in our good name.

Im Zeichen der Qualität

Sie finden die Strobel-Schutzmarke auf jeder Strobel-Maschine, die unser Werk verlässt. Und das aus gutem Grund. Denn dieses Zeichen garantiert Ihnen die hohe Qualität unserer Produkte. Qualität, die Vertrauen schafft – in unsere Technik, unseren Service und nicht zuletzt in unseren guten Namen.

Operating Manual

DC1500 – Sewing drive / Control type: ST220A

T A B L E O F C O N T E N T S

1	General safety instructions	7
2	General information	9
2.1	Technical data	9
2.2	Intended usage	9
2.3	Scope of delivery	10
2.4	Assembly of the individual sewing drive components	11
2.4.1	General information	11
2.4.2	Motor assembly	11
2.4.3	Control assembly	12
2.4.4	Set-point adjuster assembly	12
2.4.5	Pulse generator (position transmitter) assembly	12
2.4.6	Operating controls assembly	13
3	Power supply	14
3.1	General notes	14
3.2	Mains connection of the machine	14
3.2.1	Mains structure	14
3.2.2	Mains voltage and frequency	14
3.2.3	Mains connection	15
3.3	Connection of machine components	16
3.3.1	General notes	16
3.3.2	Control sockets	17
3.3.3	Motor connection cables	17
3.3.4	Connecting the various sewing drive components	18
3.3.5	Connecting the sewing machine	18
3.3.6	Connecting a digital stitch depth display	18
3.4	Connecting a sewing machine lamp with transformer	19
3.4.1	General information	19
3.4.2	Connecting the sewing machine lamp (control)	20
3.4.3	Connecting the sewing machine lamp (power switch)	22
4	Function sequence, machine class, and operating concept	23
4.1	General function sequence	23
4.2	Machine class – mode (basic function sequence)	24
4.3	Function – mode (basic function sequence)	25
4.4	Operating concept	25

5	Operating the control	26
5.1	Operating the control without operating control	26
5.1.1	Operating and display elements	26
5.1.2	Switchable functions	28
5.1.2.1	General information	28
5.1.2.2	Button assignment on the control (mode 1 and 2).....	29
5.1.2.3	Thread trimmer (mode 1 and 2).....	30
5.1.2.4	Lifting (modes 1 and 2).....	30
5.1.2.5	Basic position (modes 1 and 2)	30
5.1.2.6	End backtack “simple” (mode 2).....	31
5.1.2.7	End backtack “double” (mode 2)	31
5.1.3	Direct input of the maximum speed limit (DED).....	32
5.2	Operating the control with the V810 operating control	33
5.2.1	Operating and display elements	33
5.2.2	Switchable functions	35
5.2.2.1	General information	35
5.2.2.2	Mode (basic function sequence) – plug-in strip (V810)	35
5.2.2.3	Button assignment on the V810 operating control.....	36
5.2.2.4	Thread trimmer (mode 1, 2 and 7).....	37
5.2.2.5	Lifting (modes 1 and 2).....	37
5.2.2.6	Basic position (modes 1 and 2)	37
5.2.2.7	End backtack “simple” (mode 2).....	38
5.2.2.8	End backtack “double” (mode 2)	38
5.2.2.9	Stitch number of the stitch count (mode 7).....	39
5.2.2.10	Thread puller (mode 7).....	39
5.2.2.11	Lifting with pedal position “-2” (mode 7)	39
5.2.3	Direct input of the maximum speed limit (DED).....	40

6	Functions.....	41
6.1	Basic functions	41
6.1.1	Basic function sequence (mode).....	41
6.1.2	Motor's direction of rotation	42
6.1.3	Selection of the position transmitter	42
6.1.4	Transmission ratio.....	43
6.1.5	Positions.....	44
6.1.6	Machine speed.....	45
6.1.6.1	Positioning speed	45
6.1.6.2	Maximum speed (setting range).....	45
6.1.7	Lifting in general.....	46
6.1.8	Softstart.....	49
6.1.9	Stitch count	50
6.1.10	Turn back	51
6.1.11	Acceleration characteristics.....	52
6.1.12	Braking characteristics	53
6.1.13	Holding force during standstill	54
6.1.14	Speed graduation dispersion.....	54
6.1.15	Speed status	55
6.2	Mode-dependant functions	56
6.2.1	Thread trimmer.....	56
6.2.1.1	Thread trimmer (mode 1, 2 and 7).....	56
6.2.1.2	Run inhibition (mode 1 and 2)	57
6.2.2	Trimming device (mode 1).....	58
6.2.3	End backtack (mode 2)	59
6.2.4	Thread puller (mode 7).....	62
6.3	Additional functions of the V810 operating control.....	63
6.3.1	Machine speedometer.....	63
6.3.2	Acoustical signal	63

7	Programming the control	64
7.1	General information	64
7.2	Operating the control without operating control	64
7.2.1	Access right during command entry	64
7.2.2	Programming at the operator level	65
7.2.2.1	General information	65
7.2.2.2	Call up and change parameters one after the other	66
7.2.2.3	Call up and change parameters directly	67
7.2.2.4	Call up and change parameters by pressing the “+/-” buttons	68
7.2.3	Programming at the technician or installer level	70
7.2.3.1	General information	70
7.2.3.2	Programming the code number	71
7.2.3.3	Call up and change parameters one after the other	72
7.2.3.4	Call up and change parameters directly	72
7.2.3.5	Call up and change parameters by pressing the “+/-” buttons	73
7.2.4	Setting the positions	74
7.2.4.1	General information	74
7.2.4.2	Setting the reference position	74
7.2.4.3	Setting positions 1 and 2	75
7.3	Operating the control with the V810 operating control	76
7.3.1	Access right during command entry	76
7.3.2	Programming at the operator level	76
7.3.2.1	General information	76
7.3.2.2	Call up and change parameters one after the other	77
7.3.2.3	Call up and change parameters directly	78
7.3.2.4	Call up and change parameters by pressing the “+/-” buttons	80
7.3.3	Programming at the technician or installer level	82
7.3.3.1	General information	82
7.3.3.2	Programming the code number	83
7.3.3.3	Call up and change parameters one after the other	84
7.3.3.4	Call up and change parameters directly	85
7.3.3.5	Call up and change parameters by pressing the “+/-” buttons	85
7.3.4	Setting the positions	86
7.3.4.1	General information	86
7.3.4.2	Setting the reference position	86
7.3.4.3	Setting positions 1 and 2	87

8	Service	88
8.1	Operating without operating control	88
8.1.1	Display of the needle positions	88
8.1.2	Display of the program number	89
8.1.3	Signal test	90
8.1.3.1	General information	90
8.1.3.2	Test of the signal outputs (general)	90
8.1.3.3	Test of the signal inputs (general)	91
8.1.3.4	Test of the run inhibition in thread trimmer (mode 1 and 2)	92
8.1.3.5	Manual control signal, trimming device (mode 1)	92
8.2	Operating with the V810 operating control	93
8.2.1	Display of the needle positions	93
8.2.2	Display of the program number	94
8.2.3	Signal test	94
8.2.3.1	General information	94
8.2.3.2	Test of the signal outputs (general)	95
8.2.3.3	Test of the signal inputs (general)	96
8.2.3.4	Test of the run inhibition in thread trimmer (mode 1 and 2)	97
8.2.3.5	Manual control signal, trimming device (mode 1)	97
8.3	Installation or replacement of the control box	98
8.4	Replacement of the motor	100
8.5	Replacement of the external pulse generator (position transmitter)	101
8.6	Fault messages	102
8.6.1	General information	102
8.6.2	Programming functions and values (parameters)	102
8.6.3	Serious status	102
8.6.4	Hardware fault	102

Appendix

Circuit diagrams

Electric mains, sewing drive - sewing machine lamp:

- 258.00.27 Mains connection plan cl. general
(DC1500/DC1550 with/without sewing machine lamp gen.)
- 258.00.32 Mains facility connection plan cl. general
(DC1500/DC1550 with/without sewing machine lamp gen.)
- 258.00.29 Mains connection plan cl. 103-258M(B)
(DC1500-ST220A with/without sewing machine lamp gen.)

Connecting the sewing machine:

- 258.21.18 Electrical connection plan cl. 45, 58, 103, 120, 170
- 258.21.19 Electrical connection plan cl. 45, 103, 170 with backtack
- 258.21.22 Electrical connection plan cl. 103-258M(B)
- 258.21.21 Electrical connection plan cl. 142
- 258.21.15 Electrical connection plan cl. 200, 300
- 258.10.16 Electrical diagram cl. 218D-TP, 325-40D-TP
- 258.21.46 Electrical connection plan cl. 560

Connection digital stitch depth display:

- 258.21.31 Electrical connection plan cl. 103

Strobel - Switchable functions (DC1500-ST220A)

Strobel - Parameter list (DC1500-ST220A)

Plug in strip V810-ST220A

Spare parts data sheets

Subject to change without prior notice

1 General safety instructions

1. The sewing drive, its accessories, and auxiliary equipment may not be assembled or put into operation until the persons that have been instructed for that have read the operating manual.
2. The sewing drive, accessories, and the auxiliary equipment may be used only for their intended purpose.
3. Operation without the attached protective devices is prohibited.
4. The sewing drive has to be fully assembled before being connected to electricity.
5. Work on the electrical equipment may be done only by technicians.
6. Repairs may be carried out only by specially trained personnel.
7. The cables have to be fuse-protected for the expected power consumption and fastened well enough.
8. Cables should be laid out preferably spaced apart so that they are safely separated.
9. Cables have to be spaced at least 25 mm from moving machine parts (such as V-belts) (DIN VDE0113).
10. Make sure when connecting to the power mains that the voltage and the frequency meet the specifications given on the control's type plate.
11. Switch off the sewing drive when assembling, repairing or maintaining the machine, i.e. switch off main switch and pull the power plug (DIN VDE0113).
12. Never pull by the cable; grip the plug itself.
13. Working on parts that are under voltage is not allowed. Exemptions are covered by the DIN VDE0105 regulations.
14. Retrofitting and alterations may be carried out only if all safety regulations are observed.

15. Only original parts supplied by the manufacturer may be used for repair and maintenance.
16. Use only auxiliary equipment that has been recommended by the manufacturer or listed in the operating manual.
17. Warnings in the machine's operating manual that point out an increased risk of injury for operating personnel or damage to the machine are highlighted by the



symbol.

Observe and adhere to these instructions as well as to the generally valid safety regulations.

18. Also strictly observe the drive manufacturer's operating manual, especially the safety instructions, that are included with every drive.

2 General information

2.1 Technical data

Motor DC1500:

Maximum speed:	9000 min ⁻¹
Nom. torque:	0,64 Nm
Maximum torque:	3 Nm
Operational voltage:	230 VAC
Nom. output P1:	400 W
Maximum output:	1 000 W
Insulation class:	B
System of protection:	IP40
Length:	145.5 mm
Flange size:	80 x 75 mm
Weight:	2.125 kg
Shaft end:	cylindrical with keyway & 14k6

Control ST220A:

Voltage:	230 VAC
Frequency:	50/60 Hz
Rated voltage:	190 – 240 V / +/-10%
Output control:	120 VA
Total output P1: (control + motor)	520 W
System of protection:	IP40

2.2 Intended usage

The sewing drive is not an individually functional machine; it is intended for mounting into other machines. It may not be put into operation until it is certain that the machine into which this component is installed meets the regulations of the EC Directive.

The drive may be operated only:

- on machines processing sewing threads
- in dry rooms

2.3 Scope of delivery

- Direct current motor DC1500
- Control ST220A
with power unit N201
- Set-point adjuster EB301
- Document pack
contains: Documentation
- Accessories kit
contains: Tie rod 400...700 mm lg.
Table angle bracket for EB3xx
Fastening material
- Operating manual DC1500-ST220A

Partially:

- Sub-table assembly kit
- Pulse generator
(position transmitter) IPG001

Partially or as optional features:

- Operating controls V810
contains: operating controls Variocontrol V810
mount for operating controls
Velcro strips for mounting
Efka operating manual

2.4 Assembly of the individual sewing drive components

2.4.1 General information

When a complete machine is delivered the complete sewing drive (motor, control, etc.) is already assembled before shipment.

If a top part with sewing drive is delivered, then various components of the sewing drive or optional features need to be mounted separately. The detailed assembly instructions can be found in the operating manual or technician's instructions of the sewing machine.



CAUTION!

When selecting the set-up site and laying out the supply cables be sure to observe the safety instructions in chapter 1.

Take special care when mounting cables and keeping the clearance to moving parts (e.g. V-belts).

Assembly of optional features:

The optional feature parts (pneumatic lifting / backtack stitch, etc.) may be installed only according to the operating manual or technician's instructions of the sewing machine.

2.4.2 Motor assembly

For top-part assembly:

The motor is already mounted to the machine's top part when delivered as such.

For sub-table assembly:

The motor is mounted for sub-table assembly in the following manner:

- Use 3 screws to fasten the motor base under the table top according to the table-top diagram (see sewing machine operating manual).
- Attach the adapter ring and the holding plate complete with the belt protection to the motor (refer to the Efka sub-table assembly instructions).
- Mount the V-belt or tooth-belt wheel to the motor shaft.
- Attach the motor to the motor base (refer to the Efka sub-table assembly instructions).
- Mount V- or tooth-belt onto motor and motor top part and tension it by swivelling the motor.
- Mount motor and motor-belt guard (refer to the Efka sub-table assembly instructions and the operating manual or technician's instructions of the sewing machine).

2.4.3 Control assembly

The operating controls are assembled as following:

- Use 4 screws to fasten the controls on the right side underneath the table top.



CAUTION!

In case the main switch S0 (refer to Fig. 5) should also be used as the power switch, then the controls need to be mounted in such a way that the S0 main switch is always clearly visible and accessible especially to persons running the sewing machine.

2.4.4 Set-point adjuster assembly

The set-point adjuster is mounted as following:

- Use 3 screws to attach the angle bracket underneath the table top above the tie bar's sling point at the sewing pedal.
- Use 4 screws to attach the set-point adjuster to the angle bracket.
- Hook the tie rod into the set-point adjuster and the sewing pedal and adjust.

2.4.5 Pulse generator (position transmitter) assembly

An additional separate pulse generator is necessary in certain cases for machine classes with transmission ratios ">1" or with V-belts.

The pulse generator is mounted as following:

- Mount the pulse generator onto the handwheel intended for it, or on the respective machine flange on the machine's top part.
- The pulse generator's case has to be secured against twisting. For this a holding device, such as a bar (Ø 6 mm), should be mounted on the housing of the sewing machine or on the table top.
- Fasten the two clamping screws tight to the pulse generator.

2.4.6 Operating controls assembly

The operating controls are assembled as following:

- Use 2 screws to attach the angle bracket to the table top.
- Attach the operating controls to the angle bracket.
- Depending on the basic function sequence (mode) used, the plug-in strip above the keys has to be adapted. Cut out the appropriate plug-in strip (see “5.2.2.2 Mode (basic function sequence) – plug-in strip)” from sheet (see appendix). Replace the plug-in strip on the operating controls by pulling it out sideways (right side).

3 Power supply

3.1 General notes

	CAUTION! Work on the sewing machine's electrical equipment or sewing drive may only be done by electricians! There is the
	DANGER of a fatal electrical shock. When working on the electrical equipment, the machine with the S0 main switch has to be switched off and the power plug pulled out! The operating instructions (including safety instructions) of the sewing machine and sewing drive must be observed!

3.2 Mains connection of the machine

3.2.1 Mains structure

	CAUTION! The sewing drive may only be connected to an earthed alternating voltage mains, i.e. with an earth conductor system!
---	--

The sewing drive or sewing machine may only be operated with an earth conductor at a functioning earth conductor system that complies with all local provisions and regulations.

The protective effect of the earth conductor must not be voided when connecting, for instance, with extension cords without earth conductors. Any interruption to the earth conductor inside or outside the sewing drive is prohibited.

3.2.2 Mains voltage and frequency

	CAUTION! The range of the rated voltage and frequency for the sewing drive is 190–240 V 50/60 Hz. The mains voltage and frequency have to lie within this range!
---	---

3.2.3 Mains connection



CAUTION!

The sewing machine **must** be connected to the mains power supply with a plug connection (power plug)!



CAUTION!

The safety instructions in Chapter 1 must be observed when connecting and laying the connection cables.

When laying the cables, ensure in particular that distance is kept to movable parts (e.g. V-belts) and their mountings.

The mains cable may be fused with max. 16 A.

See also the wiring diagrams of the individual classes of machines that are in the appendix.

Instructions on laying the cables:

Protect the mains cable being laid against any expected stresses and secure adequately (incl. possible strain relief).

Lay and secure the mains cable so that it has a minimum distance of 25 mm to the movable parts.

To ensure safe separation, it is preferable to lay the mains cables spatially apart from other cables/low voltage lines. A rectangular crossing is better than one at a small angle; avoid a parallel guide.

3.3 Connection of machine components

3.3.1 General notes



CAUTION!

Before plugging in or pulling a connector plug, it is necessary to switch off the drive with the S0 main switch and to disconnect the power plug.



CAUTION!

The safety instructions in Chapter 1 must be observed when selecting an assembly location, and when laying the connection cables.

When laying the cables, ensure in particular that distance is kept to movable parts (e.g. V-belts) and their mountings.

See also the wiring diagrams and assembly plans of the individual classes of machines that are in the appendix.

Laying the cables:

Protect the cables being laid against any expected stresses and secure adequately (incl. possible strain relief).

Lay and secure the cables so that they have a minimum distance of 25 mm to the movable parts.

To ensure safe separation, it is preferable to lay cables and low voltage lines spatially apart from other. A rectangular crossing is better than one at a small angle; avoid a parallel guide.

3.3.2 Control sockets

- B2** Motor sensors connection
- B18** Light barrier module connection, external pulse generator or digital stitch depth display
- B41** Motor supply connection
- B80** Set-point adjuster connection
- B776** Operating controls V810 connection
- ST2** Sewing machine connection

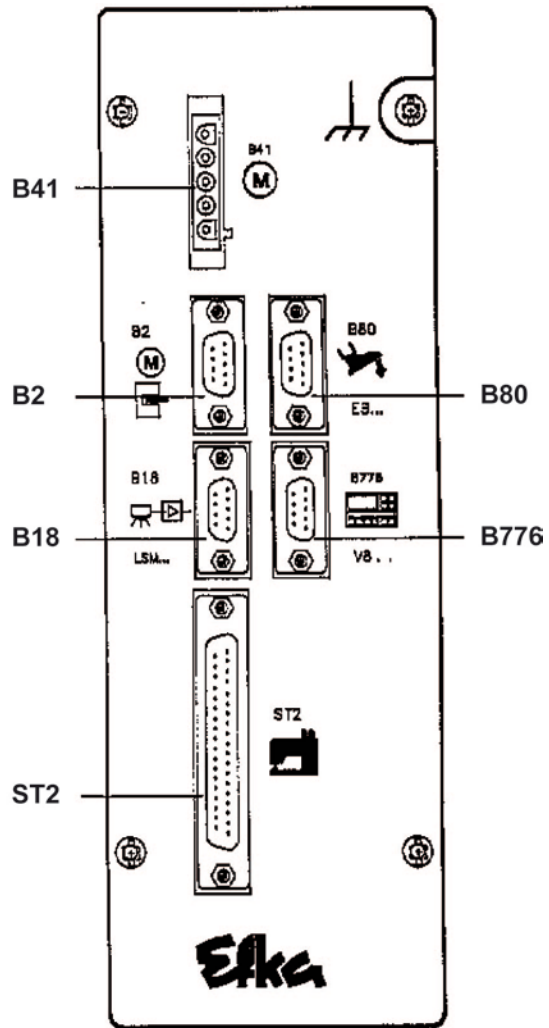

Anschlussbuchsen-ST220A

Fig. 1

3.3.3 Motor connection cables

- 1** Cable 1 for motor supply
- 2** Cable 2 for motor sensors

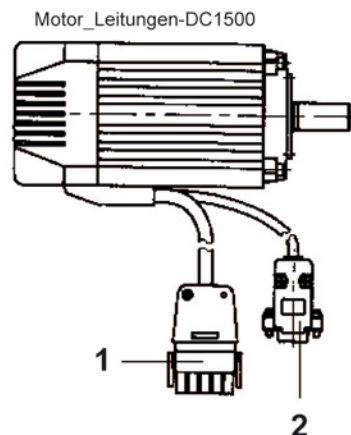

Fig. 2

3.3.4 Connecting the various sewing drive components

- Lay out cable 1 of the motor and insert the plug into socket B41 of the control (Fig. 1 + Fig. 2).
- Lay out cable 2 of the motor and insert the plug into socket B2 of the control and fasten the screws (Fig. 1 + Fig. 2).
- Lay out set-point adjuster cable and insert the plug into socket B80 of the control and fasten the screws (Fig. 2).
- Lay out cable of the light barrier (if available) and insert the plug into socket B18 of the control and fasten the screws (Fig. 1).
- Lay out cable of the external pulse generator (if available) and insert the plug into socket B18 of the control and fasten the screws (Fig. 1).
- Lay out cable of the operating controls (if available) and insert the plug into socket B776 of the control and fasten the screws (Fig. 1).

3.3.5 Connecting the sewing machine

- Lay out cables of the sewing machine (if available) and insert the plug into socket ST2 of the control and fasten the screws (Fig. 1).

Circuit diagrams:

Refer to the appendix Connection sewing machine

3.3.6 Connecting a digital stitch depth display

For some machine classes there is the option to attach a digital stitch depth display (DSA= "digital stitch depth display") directly to the control (refer to the operating manual or technician's instructions of the sewing machine).

Connection:

- Lay out cable of the digital stitch depth display and insert the plug into socket B18 of the control and fasten the screws tightly (Fig. 1).

Technical data (socket B18):

- Voltage: 5 VDC (0 V = PIN5 / 5VDC = PIN4)
- max. current consumption: 100 mA

Circuit diagram:

Refer to the appendix Connection digital stitch depth display.

3.4 Connecting a sewing machine lamp with transformer

3.4.1 General information



CAUTION!

When connecting a sewing machine lamp be sure to observe the safety instructions. In particular the connection of the sewing machine lamp may be done only by an electrician.



CAUTION!

If there is a separate power switch on the sewing machine, then the sewing machine lamp always has to be connected to the power switch and not to the control.



CAUTION!

The sewing machine lamp may not be put into operation until its operation mode is known. The sewing machine lamp may only be used as intended.



CAUTION!

Before connecting the sewing machine lamp check that the electrical connection specifications of the sewing machine lamp, especially the network voltage and frequency are appropriate for your electric network.



CAUTION!

Once the sewing machine lamp has been connected it is constantly under voltage (190 - 230 V) even when the main/power switch on the control is off. Only sewing machine lamps with a transformer may be connected to the control.

3.4.2 Connecting the sewing machine lamp (control)



CAUTION!

Before opening the control it is necessary to switch off the drive by the S0 main switch and to disconnect the power plug.



CAUTION!

Discharge your body's static before opening the control. To do so touch a well-earthed part that has a metal surface.

- Switch the control off electrically by the main switch S0 (Fig. 4) and pull the power plug.
- Unscrew the control from the machine table.
- Open 2 screws (A) in the front and back (Fig. 3).
- Take off left housing part (Fig. 3).
- Pull the connection cable of the sewing machine lamp through the separate cable bushing and fasten with cable binders. Be sure to read the corresponding circuit diagrams in the appendix: "Electric mains, sewing drive - sewing machine lamp".
- In the (B) area clamp the blue and brown stranded conductors in the 2-pin strip terminal on the printed board (Fig. 3). Be sure to read the corresponding circuit diagrams in the appendix "Electric mains, sewing drive – sewing machine lamp".
- Close the housing and screw back together.
- Mounting the control to the machine table.
- Attach sewing machine lamp and lay out cables.

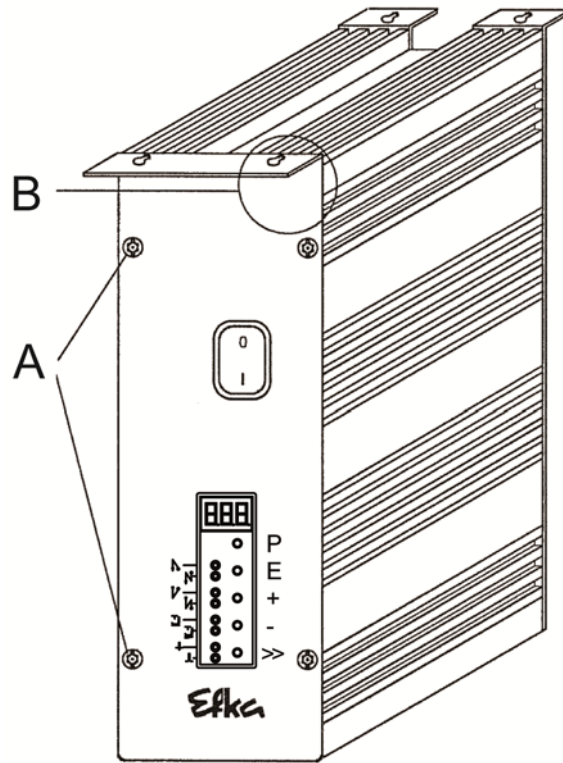

Anschluss_Nähleuchte_ST220A_02

Fig. 3

3.4.3 Connecting the sewing machine lamp (power switch)

	CAUTION!
Before opening the power switch it is necessary to switch off the drive by the main/power switch and to disconnect the power plug.	

- Switch off power switch and pull the power plug.
- Unscrew push button (A) and withdraw it (Fig. 4).
- Open the power switch with a screwdriver (B) (Fig. 4).
- Mount separate cable connection (C) to the back of the power switch (Fig. 4).
- Pull the connection cable (D) of the sewing machine lamp through the separate cable bushing and fasten with cable binders (Fig. 4).
- Affix blue conductor wire to terminal screw 3 and brown conductor wire to terminal screw 1 of the power switch. Be sure to read the corresponding circuit diagrams in the appendix "Electric mains, sewing drive - sewing machine lamp".
- Affix earth conductor wire to terminal screw of the power switch housing. Be sure to read the corresponding circuit diagrams in the appendix "Electric mains, sewing drive - sewing machine lamp".
- Close the housing and screw push button back on.
- Attach sewing machine lamp and lay out all cables.

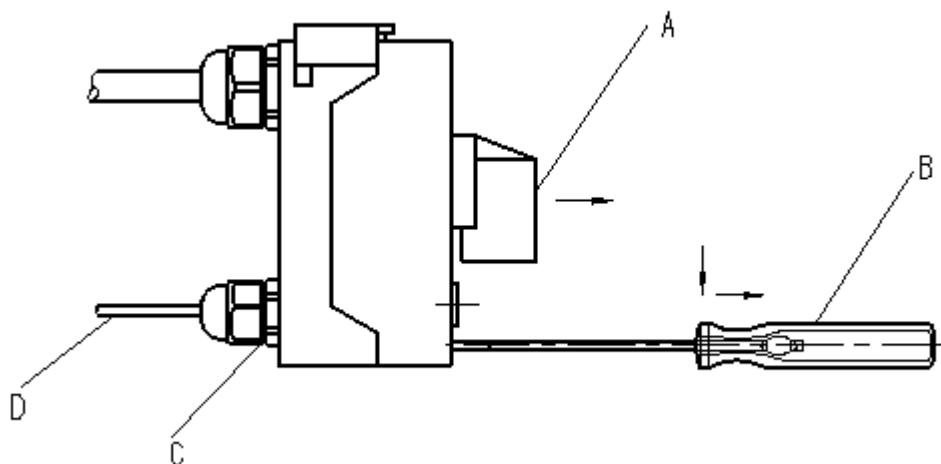

Fig. 4

4 Function sequence, machine class, and operating concept

4.1 General function sequence

The ST220A control is equipped with the appropriate function sequence for almost all Strobel machine classes.

The exact function sequence for a machine class is determined at the control by the basic function sequence (mode), the function parameters and the switchable functions. The control is optimally control-technically adapted to the respective machine class by correct settings.

By setting the mode (parameter F-290) at the control the basic function sequence is set for the selected machine class.

The exact function sequence for the selected machine class is determined by setting certain function parameters or switchable functions while taking into consideration any sub-classes or its optional features.

The function parameters or the switchable functions are preset in the control by preset values or functions. Some of these parameters or functions need to be altered from the preset values or functions for certain machine classes depending on the sub-class and optional features.

When a complete machine or a top part with sewing drive is delivered all function parameters and functions have been already properly set.

4.2 Machine class – mode (basic function sequence)

Machine class	Mode (basic function sequence)							
	1	2	7					
45-123; -223	X							
45-123R; -223R		X						
58-4	X							
103-161; -180; -191; -254; -256	X							
103-180R; -191R		X						
103-258M; -258MB	X							
123-10	X							
124-14	X							
141-23EV; -30; -40; -50	X							
142-30	X							
170-22	X							
170-22R		X						
218S; 218TP; 327	X							
310; 3100; 3200	X							
325-40TP	X							
560-11			X					

4.3 Function – mode (basic function sequence)

Function		Mode (basic function sequence)							
		1	2	7					
Designation	Socket/pin								
Outputs:									
Locking system (VR)	ST2 / 34		X						
Lifting (LÜ)	ST2 / 35	X	X	X					
Thread trimmer (FA)	ST2 / 28 ST2 / 37	X	X	X					
Hold back (EINH)	ST2 / 28								
Partial lifting (TLÜ)	ST2 / 37								
Thread tension Lifting (FSPL)	ST2 / 27								
Thread puller (FZ)	ST2 / 27			X					
Trimming device (BSV)	ST2 / 32	X							
Inputs:									
Run inhibition (LSP)	ST2 / 07	X	X						
Button for temporary lifting (T-ZLÜ)	ST2 / 11								
Button for partial lifting (T-TLÜ)	ST2 / 11								
Button for sew-up stitch (T-VNST)	ST2 / 11								

4.4 Operating concept

Modes 1 and 2:

The ST220A control is programmed and operated by the control panel on the control.

For improved control, programming as well as for trouble shooting the V810 operating control can be attached to the control, which is available as an optional feature.

Modes 7:

The ST220A control is programmed and operated by the V810 control panel which is part of the standard delivery.

5 Operating the control

5.1 Operating the control without operating control

5.1.1 Operating and display elements

(Refer to Fig. 5)

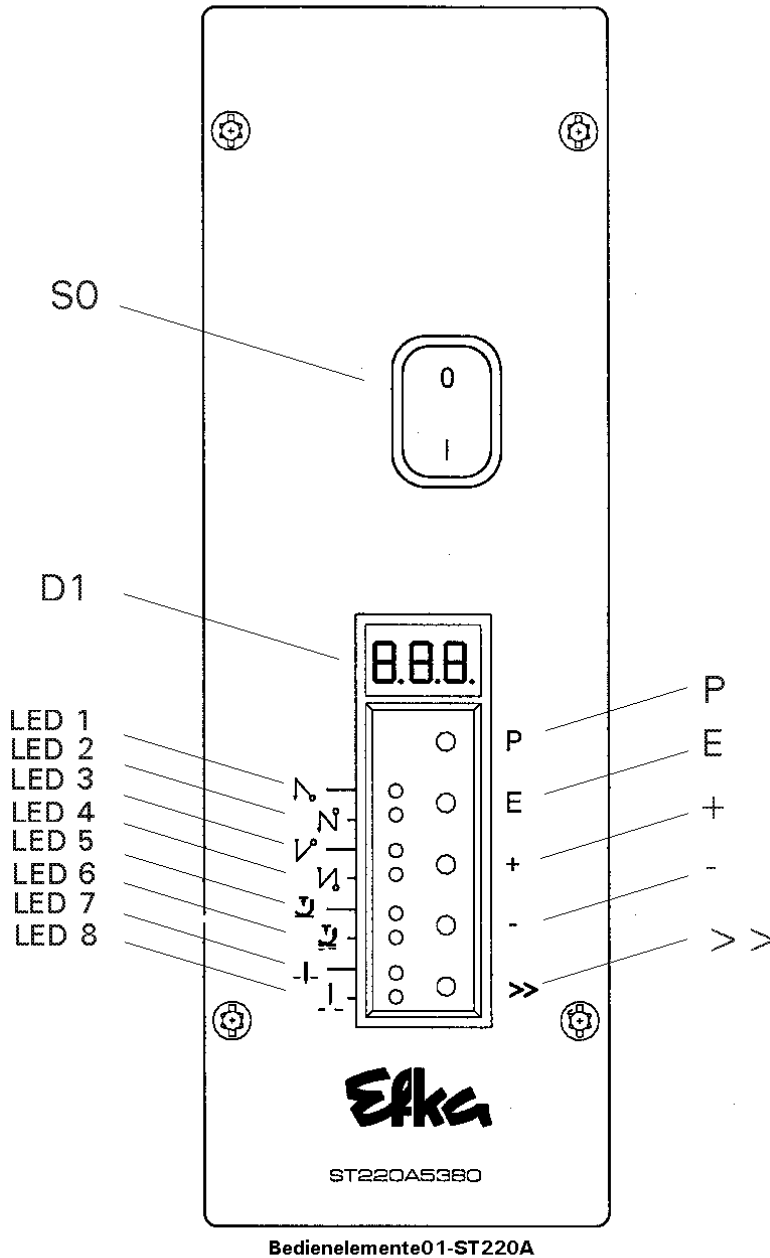

Fig. 5

S0 Main switch

D1 3-digit display

Button Function in sewing mode

(after main switch S0 on)

P Start and end programming mode

E Functions according to mode (parameter F-290)

+ Functions according to mode (parameter F-290)

- Functions according to mode (parameter F-290)

>> Functions according to mode (parameter F-290)

Button Function in programming mode

P Start and end programming mode

E As acknowledgement button for changes

+ Increase parameter number or value

- Decrease parameter number or value

>> Shift button

LED Function

1 + 2 Display of the “E” button status

3 + 4 Display of the “+” button status

5 + 6 Display of the “-” button status

7 + 8 Display of the “>>” button status

5.1.2 Switchable functions

5.1.2.1 General information

Switchable functions can be changed by pressing a button. The switch status is displayed by the respective light emitting diode (LED) (refer to Fig. 5 and the assignment table).

Assignment table button - LEDs:

Button	LED number
E	LED1 + LED2
+	LED3 + LED4
-	LED5 + LED6
>>	LED7 + LED8

Depending on the selection of the basic function sequence (mode) in the F-290 parameter the various buttons are assigned to different switchable functions.

Switching the functions is only possible when there is no sewing.

The changes are saved immediately following the setting without having to “sew on”.

5.1.2.2 Button assignment on the control (mode 1 and 2)

Button	Mode 1	Mode 2
"E"	not assigned LED1 = off not assigned LED2 = off	not assigned LED1 = off not assigned LED2 = off
"+"	nicht belegt LED3 = aus nicht belegt LED4 = aus	End backtack "simple" LED3 = on/off End backtack "double" LED4 = on/off
"_"	Thread trimmer On/Off LED5 = on/off Autom. lifting On/Off LED6 = on/off	Thread trimmer On/Off LED5 = on/off Autom. lifting On/Off LED6 = on/off
">"	Basic position 1 LED7 = on/off Basic position 2 LED8 = on/off	Basic position 1 LED7 = on/off Basic position 2 LED8 = on/off

5.1.2.3 Thread trimmer (mode 1 and 2)

Function without operating control	Button
Thread trimmer (FA) On/Off	-

This function switches the thread trimmer on or off.

Thread trimmer On ⇒ LED5 = on

Thread trimmer Off ⇒ LED5 = off

5.1.2.4 Lifting (modes 1 and 2)

Function without operating control	Button
Automatic lifting (LÜ) On/Off	-

This function switches the automatic lifting on or off.

Autom. lifting On ⇒ LED6 = on

Autom. lifting Off ⇒ LED6 = off

5.1.2.5 Basic position (modes 1 and 2)

Function without operating control	Button
Basic position Pos.1/Pos.2	>>

This function selects the basic position.

Basic position Pos.1 ⇒ LED7 = on & LED8 = off

Basic position Pos.2 ⇒ LED7 = off & LED8 = on

5.1.2.6 End backtack “simple” (mode 2)

Function without operating control	Button
End backtack “simple” On/Off	+

This function switches the end backtack “simple” on or off.

End backtack “simple” On ⇒ LED3 = on

End backtack “simple” Off ⇒ LED3 = off

Sequence of the “simple” end backtack function:

After pedal position “-2” (in the stitch), the stitches of the “simple” (F-002) end backtack are processed. A backtack signal (VR to ST2/PIN34) is given by the control during the processing of the stitches.

5.1.2.7 End backtack “double” (mode 2)

Function without operating control	Button
End backtack “double” On/Off	+

This function switches the end backtack “double” on or off.

End backtack “double” On ⇒ LED4 = On

End backtack “double” Off ⇒ LED4 = Off

Sequence of the “double” end backtack function:

After pedal position “-2” (in the stitch), the stitches of the “simple” (F-002) end backtack are processed first after the backtack signal (ST2/ 34) is given. After that, the backtack signal is switched off and the stitches form the end backtack “double” (F-003) are processed.

5.1.3 Direct input of the maximum speed limit (DED)

Function without operating control	Button
Direct input of the maximum speed limit	+/-

Function:

In order to limit the maximum speed of the sewing machine to the appropriate rate for the task the setting can be adjusted at the direct function level.

The setting can be changed at the control by pressing the “+/-” buttons while the sewing machine is running or pausing.

The setting range lies between the parameter values F-111 (maximum value) and F-121 (minimum value).

This function is blocked at the beginning and the end of a stitch.

The current value is shown in the display and needs to be multiplied by 10.

5.2 Operating the control with the V810 operating control

5.2.1 Operating and display elements

(Refer to Fig. 6 + Fig. 7)

At the control:

S0 Main switch

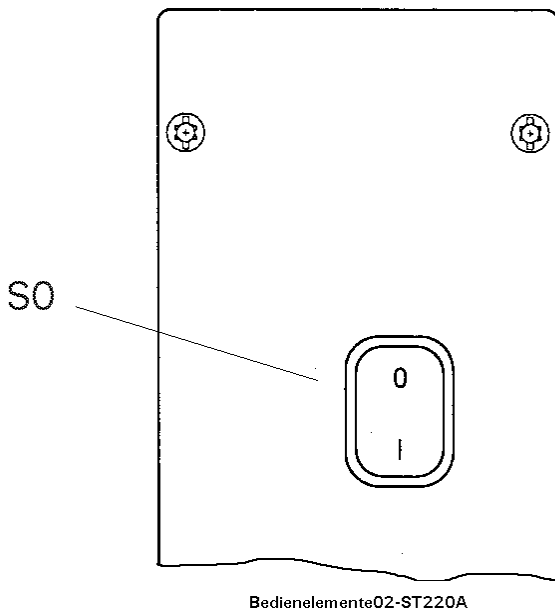

Fig. 6

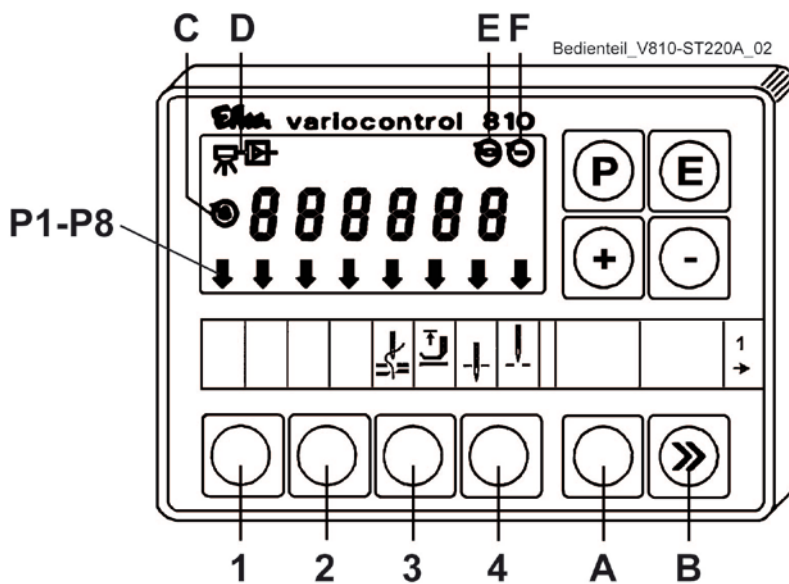

Fig. 7

At the V810 operating control:

Button Function in sewing mode (after main switch S0 on)

- P** Start and end programming mode
- E** No function
- +** Increase the speed (DED, see chapter "5.3")
- Decrease the speed (DED, see chapter "5.3")
- 1 - 4** Functions according to mode (parameter P-290)
- A** No function
- >>** No function

Button Function in programming mode

- P** Start and end programming mode
- E** As acknowledgement button for changes
- +** Increase parameter number or value
- Decrease parameter number or value
- 1 - 4** No function
- A** No function
- >>** Shift button

Symbol Function

- C** Automatic speed active
- D** Light barrier on
- E** Machine runs
- F** Limited speed active
- P1 - P8** Display of the status of the button below it

5.2.2 Switchable functions

5.2.2.1 General information

Switchable functions can be changed by pressing a button. The switch status is displayed by the respective arrow over the button (refer to leaflet Fig. 6, Fig. 7 and the assignment table).

Assignment table button - arrows:

Button	Arrow
1	Left and right arrow over the "1" button
2	Left and right arrow over the "2" button
3	Left and right arrow over the "3" button
4	Left and right arrow over the "4" button

Depending on the selection of the basic function sequence (mode) in the F-290 parameter the various buttons are assigned to different switchable functions.

Switching the functions is only possible when there is no sewing.

The changes are saved immediately following the setting without having to "sew on".

5.2.2.2 Mode (basic function sequence) – plug-in strip (V810)

	<p>CAUTION!</p> <p>The plug-in strip over the operating control's buttons is only valid for the mode whose functions match the symbols. For modes with other functions replace the respective plug-in strip on the operating controls by pulling it out to the side.</p>
---	---

Mode (basic function sequence)	Plug-in strip (V810)							
	1	2	4					
Mode 1	X							
Mode 2		X						
Mode 7			X					

5.2.2.3 Button assignment on the V810 operating control

Button	Mode 1	Mode 2	Mode 7	
	Plug-in strip 1	Plug-in strip 2	Plug-in strip 4	
"1"	not assigned left arrow= off not assigned right arrow= off	not assigned left arrow= off not assigned right arrow= off	The value of the stitch count is briefly displayed and can be changed by pressing the +/- button	
"2"	not assigned left arrow= off not assigned right arrow= off	End backtack "simple" left arrow= on/off End backtack "double" right arrow= on/off	not assigned left arrow= off not assigned right arrow= off	
"3"	Thread trimmer On/Off left arrow= on/off Autom. lifting On/Off right arrow=on/off	Thread trimmer On/Off left arrow= on/off Autom. lifting On/Off right arrow= on/off	Thread trimmer On/Off left arrow= on/off Thread puller On/Off right arrow= on/off	
"4"	Basic position Position1 left arrow= on/off Basic position Position2 right arrow=on/off	Basic position Position1 left arrow= on/off Basic position Position2 right arrow=on/off	Lifting up from the stitch with pedal setting "-2" On/Off left arrow= on/off	

5.2.2.4 Thread trimmer (mode 1, 2 and 7)

Function with operating control	Button (V810)
Thread trimmer (FA) On/Off	3

This function switches the thread clipper on or off.

Thread trimmer On ⇒ left arrow = on

Thread trimmer Off ⇒ left arrow = off

5.2.2.5 Lifting (modes 1 and 2)

Function with operating control	Button (V810)
Lifting (LÜ) On/Off	3

This function switches the automatic lifting on or off at the end of a stitch.

Autom. lifting On ⇒ right arrow = on

Autom. lifting Off ⇒ right arrow = off

5.2.2.6 Basic position (modes 1 and 2)

Function with operating control	Button (V810)
Basic position Pos.1/Pos.2	4

This function selects the basic position.

Basic position Pos.1 ⇒ left arrow = on & right arrow = off

Basic position Pos.2 ⇒ left arrow = off & right arrow = on

The basic position is the position in which the sewing drive is positioned when the sewing stops (sewing machine in the stitch, pedal position "0").

5.2.2.7 End backtack “simple” (mode 2)

Function with operating control	Button (V810)
End backtack “simple” On/Off	2

This function switches the end backtack “simple” on or off.

End backtack “simple” On ⇒ left arrow= on

End backtack “simple” Off ⇒ left arrow= off

When the function is switched on, the stitch number of the simple end backtack (F-002) is briefly displayed and can be changed during the display by pressing the “+/-” buttons.

Sequence of the “simple” end backtack function:

After pedal position “-2” (in the stitch), the stitches of the “simple” (F-002) end backtack are processed. A backtack signal (VR to ST2/PIN34) is given by the control during the processing of the stitches.

5.2.2.8 End backtack “double” (mode 2)

Function with operating control	Button (V810)
End backtack “double” On/Off	2

This function switches the end backtack “double” on or off.

End backtack “double” On ⇒ right arrow= On

End backtack “double” Off ⇒ right arrow = Off

When the function is switched on, the stitch number of the double end backtack (F-003) is briefly displayed and can be changed during the display by pressing the “+/-” buttons.

Sequence of the “double” end backtack function:

After pedal position “-2” (in the stitch), the stitches of the “simple” (F-002) end backtack are processed first after the backtack signal (ST2/PIN34) is given. After that, the backtack signal is switched off and the stitches form the end backtack “double” (F-003) are processed.

5.2.2.9 Stitch number of the stitch count (mode 7)

Function with operating control	Button (V810)
Stitch number of the stitch count	1

This function displays the stitch number of the stitch count for about 2 seconds. It can be changed during the display by pressing the “+/-” buttons.

5.2.2.10 Thread puller (mode 7)

Function with operating control	Button (V810)
Thread puller (FZ) On/Off	2

This function switches the thread puller on or off.

Thread puller On ⇒ right arrow = on

Thread puller Off ⇒ right arrow = off

5.2.2.11 Lifting with pedal position “-2” (mode 7)

Function with operating control	Button (V810)
Lifting with pedal position “-2” On/Off	4

This function switches the lifting on or off with pedal setting “-2” when away from the stitch.

Lifting On ⇒ left arrow = on

Lifting Off ⇒ left arrow = off

The function is intended for various control, adjustment, and setting tasks:

Sewing machine is away from the stitch:

Pedal position “0” ⇒ lifting open

Pedal position “-2” ⇒ lifting closed

5.2.3 Direct input of the maximum speed limit (DED)

Function	Button (V810)
Direct input of the maximum speed limit	+/-

Function:

In order to limit the maximum speed of the sewing machine to the appropriate rate for the task the setting can be adjusted at the direct function level.

The setting can be changed at the V810 operating control by pressing the “+/-” buttons while the sewing machine is running or pausing.

The setting range lies between the parameter values F-111 (maximum value) and F-121 (minimum value).

This function is blocked at the beginning and the end of a stitch.

The current value is shown in the display for about 2 seconds after the button is pressed.

6 Functions

6.1 Basic functions

6.1.1 Basic function sequence (mode)

Function with or without operating control	Parameter
Basic function sequence (machine mode)	F-290

The individual basic function sequences of the control can be selected by this function.

	<p>CAUTION!</p> <p>A setting should be done only during the installation of the sewing machine (refer to chapter 8.3 Installation or replacement of the control box).</p> <p>The setting has to be done very carefully because a faulty setting can damage the control or the sewing machine.</p> <p>Disconnect the connection cables of the in- and outputs before setting the basic function sequences.</p> <p>It needs to be additionally ensured that the intended sewing machine is installed for the set basic function sequence.</p> <p>The setting with function F-290 is to be done only after the power is switched on.</p>
--	--

Function with or without operating control	Parameter
Selection of the number of the plug-in strip for the V810 operating control	F-291

This function selects the plug-in strip for the V810 operating control.

Depending on the basic function sequence used, the respective plug-in strip on the operating controls has to be exchanged by pulling it out to the side.

6.1.2 Motor's direction of rotation

Function with or without operating control	Parameter
Direction of rotation of the DC motor	F-161

This function sets the DC motor's direction of rotation.

Explanation of the parameter values used:

F-161 = 0 Right-ward motor rotation
(as seen towards the motor shaft)

The rotational direction of all Strobel machine classes is to the right, i.e. the correct rotation of the of the machine hand wheel is clockwise when looking at it.

6.1.3 Selection of the position transmitter

Function with or without operating control	Parameter
Selection of the position transmitter	F-270

This function sets the position transmitter used.

Explanation of the parameter values used:

F-270 = 0 The control needs only the position transmitter integrated into the motor. The individual positions are set by the parameters F-170 and F-171.

F-270 = 4 The control needs in addition to the position transmitter integrated into the motor an external pulse generator. The individual positions are set as well by the parameters F-170 and F-171.

6.1.4 Transmission ratio

Function with or without operating control	Parameter
Transmission motor shaft to machine shaft	F-272

This function sets the transmission ratio of motor shaft to sewing machine shaft. The transmission ratio always needs to be entered so that the set speeds correspond to the required sewing speeds.

CAUTION!

When using the position transmitter integrated in the motor (incremental pickup) the transmission ratio has to be determined and set as precisely as possible.

When using an additional external pulse generator the transmission ratio has to be roughly determined and set. During the first run of the motor the control determines the precise transmission ratio by itself and corrects the set parameter value if necessary.

The transmission ratio can be selected from the 015...255 range.

Formula:

$$\text{Value of parameter 272} = \frac{\text{diameter of motor's pulley}}{\text{diameter of machine's pulley}} \times 100$$

Examples:

If the diameter of the motor' pulley is 40 mm and the diameter of the pulley of the sewing machine's top part is 80 mm, then the value "50" has to be entered.

If the value "200" is entered for parameter 272 then the pulley on the motor has to be twice as large as the one on the sewing machine top part.

6.1.5 Positions

Function with or without operating control	Parameter
Setting the reference position	F-170

This function sets the reference position.

Function with or without operating control	Parameter
Setting positions 1 and 2	F-171

This function sets the two positions.

The ST220A control has two positions. The positions are set exclusively by programming the control.

A position is determined by a position input and output value. The values correspond to the number of increments (steps), counted from an entered reference position. A rotation is divided into 360 steps (increments), i.e. 1 step = 1 degree.

CAUTION!

In order to ensure a safe or proper sequence there should be at least 25 steps (increments) between the two positions, that is between position output value of the one and position input value of the other position.

Furthermore there needs to be always at least 25 steps between the position input value and output value of the same position (very important for the internal function of the control).

For the precise programming of the individual positions refer to chapter 7.2.4 Setting the positions (without operating control) and 7.3.4 Setting the positions (with V810 operating control).

The setting of the positions can be easily checked using the F-172 function. Refer to chapter 8.1.1 Display of the needle position (without operating control) or 8.2.1 Display of the needle position (with V810 operating control).

6.1.6 Machine speed

6.1.6.1 Positioning speed

Function with or without operating control	Parameter
Positioning speed n1	F-110

The positioning speed is the speed of the machine during a positioning process.

CAUTION!

To ensure a reliable or correct sequence, the positioning speed (F-110) always needs to be less than the lower limit of the setting range of the maximum speed (F-121).

6.1.6.2 Maximum speed (setting range)

Function with or without operating control	Parameter
Maximum speed (setting range) n2-	F-111

The maximum speed is the highest speed the sewing machine can reach (pedal position "+12") or that can be set by DED.

CAUTION!

The machine's maximum permitted speed may not be surpassed.
When using the position transmitter integrated in the motor (incremental pickup) the transmission ratio also always has to be properly set.
A faulty setting can damage the sewing machine.

Function with or without operating control	Parameter
Lower limit of the setting range of n-max	F-121

The lower limit of the setting range of the maximum speed is the lowest speed of the sewing machine that can be entered as maximum speed in the parameter F-111 (at pedal position "+12").

CAUTION!

To ensure a reliable or correct sequence, the lower limit of the setting range of the maximum speed (F-121) always needs to be greater than the currently set positioning speed (F-110).

6.1.7 Lifting in general

The following functions have an influence on lifting:

Function with or without operating control	Parameter
Lifting (LÜ) with pedal position "-1"	F-019

This function opens the lifting with pedal position "-1", i.e. without activating the thread trimmer.

Explanation of the parameter values used:

F-019 = 1 Lifting with pedal position "-1" blocked.

F-019 = 3 Lifting with pedal position "-1" released.

The lifting is open as long as the pedal is in the "-1" pedal position.

Function with or without operating control	Parameter
Switch delay of the lifting (LÜ) at pedal position "-1"	F-201

This function sets a delay time for the evaluation of the "-1" pedal position.

Setting a long delay prevents unintentional lifting before the thread trimming during a change of pedal position " ≥ 0 " to "-2".

Function with or without operating control	Parameter
Starting delay after the lifting signal (LÜ) switches off	F-202

This function sets a delay before starting the sewing machine that becomes active when the sewing machine starts up (with pedal position ">0" / lifting open).

The starting delay has to be set so that when the pedal is fully pressed, the lifting is definitely closed before the sewing machine starts up.

Function with or without operating control	Parameter
Delay time lifting (LÜ) On	F-288

This function sets a delay time for the lifting that becomes active after the sewing machine is positioned at the stitch end.

Function with or without operating control	Parameter
Lifting mode	F-236

This function is used to determine the individual function processes for the lifting.

Explanation of the parameter values used:

F-236 = 0 Lifting is registered at the stitch end (pedal position "-2").
Registration doesn't end until pedal position "≥ 1".

F-236 = 2 Lifting is registered at the stitch end (pedal position "-2").
Registration ends already at pedal position "+1/2".

The electrical lifting signal can also be clocked. This function can be used when the spool of the attached magnetic valve or magnet does not have 100% continuous duty.

The lifting is opened by full drive. Afterwards there is an automatic switch to partial drive to reduce the load on the drive and the attached spool of the magnetic valve or magnet.

Function with or without operating control	Parameter
Full drive time lifting (LÜ)	F-203

This function sets a full drive time for the lifting that becomes active after the signal is switched on.

Function with or without operating control	Parameter
Holding force (continuous duty) of the lifting (LÜ)	F-204

This function sets holding force (continuous duty) of the lifting.

Value	Holding force	Continuous duty
1	weak holding force	1%
100	strong holding force (full drive)	100%

	<p>CAUTION!</p> <p>If the holding force is too strong (continuous duty = ED), then the spool or drive can be ruined.</p> <p>Be sure to observe the permissible continuous duty of the spool and set the percentile value appropriate for it.</p>
---	---

Function with or without operating control	Parameter
Upper limit (F-204) continuous duty for lifting (LÜ)	F-254

This function sets the upper limit of the holding force (continuous duty) of the lifting that can be set in parameter F-204.

6.1.8 Softstart

The following functions have an influence on the softstart:

Function with or without operating control	Parameter
Softstart On/Off	F-134

This function switches the softstart on or off.

The function is used:

- after power on
- at the beginning of a new stitch
- speed is pedal-controlled and limited
- lower dominating speed of a parallel-running function (e.g. start backtack)
- stitch count is synchronized on position 1
- interruption by pedal position "0"
- interruption by pedal full back (pedal position "-2")

Function with or without operating control	Parameter
Stitch number softstart	F-100

This function sets the number of stitches for a softstart.

Function with or without operating control	Parameter
Softstart speed n6	F-115

The softstart speed is the speed of the machine after completing the softstart stitches.

6.1.9 **Stitch count**

The following functions have an influence on the stitch count:

Function with or without operating control	Parameter
Stitch count On/Off	F-015

This function switches the stitch counting on or off.

Function with or without operating control	Parameter
Stitch number of the stitch count	F-007

This function sets the number of stitches for a stitch count.

Only mode 7:

Refer also to chapter 5.2.2.9 Stitch number of the stitch count (mode 7)

Function with or without operating control	Parameter
Speed for the stitch count n12	F-118

The stitch count speed is the speed of the sewing machine after completing the stitch count.

Prerequisite:

Speed is activated by parameter F-141.

Function with or without operating control	Parameter
Speed status for a stitching with stitch count	F-141

This function sets a certain speed characteristic for the “stitching with stitch count” sequence.

Explanation of the parameter values used:

- F-141 = 0 pedal-dependant speed, controllable up to the set maximum speed (F-111).
An interruption can be done by pressing the pedal to pedal position “-2”.
- F-141 = 3 fixed speed (F-118) once the pedal is briefly pressed, which means that the sequence runs automatically then.
An interruption can be done by pressing the pedal to pedal position “-2”.

Function with or without operating control	Parameter
Automatic lifting at stitch count or light barrier	F-023

This function switches the automatic lifting on or off at stitch count or light barrier.

6.1.10 Turn back

The following functions have an influence on the turn back of the sewing drive:

Function with or without operating control	Parameter
Turn back On/Off	F-182

This function switches the turn back on or off.

The turn-back sequence doesn't start until all other functions such as thread trimming, open lifting and so forth are done.

Following a switch delay the sewing machine turns back the number of turn-back steps at positioning speed.

Function with or without operating control	Parameter
Switch delay for turn back	F-181

This function sets the switch delay for the turn back that becomes active following the normal functions such as thread trimming, open lifting and so on.

Function with or without operating control	Parameter
Number of turn-back steps	F-180

This function sets the number of turn-back steps.

A turn-back step is about 1.0 degree.

6.1.11 Acceleration characteristics

The following functions have an influence on the acceleration or starting characteristics:

Function with or without operating control	Parameter
Accelerating power of the drive	F-220

This function sets the acceleration characteristics of the drive.

The dynamics of the drive's acceleration can be adapted to the sewing machine's characteristics (easy/heavy).

For the setting:

high setting value = great acceleration

A high setting value of the acceleration characteristics plus a possibly highly set braking parameter value can cause light machines to run rough. In this case you should try to optimise the settings.

Note on blindstitch machines that one or two piercings can be done at the beginning of a stitch if the acceleration is too strong.

6.1.12 Braking characteristics

The following functions have an influence on the braking characteristics:

Function with or without operating control	Parameter
Braking effect when changing the set-point ≤ 4 steps	F-207

Function with or without operating control	Parameter
Braking effect when changing the set-point ≥ 5 steps	F-208

This function sets the braking characteristics of the drive.

Parameter F-207 influences the braking effect for the stop.

Parameter F-208 influences the braking effect between the speed graduations.

For the setting of both parameters:

high setting value = strong braking

Note on blindstitch machines that one or two piercings can be done at the end of a stitch if the braking is too strong.

6.1.13 Holding force during standstill

The following functions have an influence on the holding force during standstill:

Function with or without operating control	Parameter
Holding force during machine standstill	F-153

This function sets holding force of the machine when it is at a standstill.

This function prevents the undesirable “wandering” of the needle during standstill.

The effect can be felt by turning the handwheel.

The holding force has effect:

- at standstill (after power on or stitch end)
- during stop in the stitch

For the setting:

high setting value = strong holding force

6.1.14 Speed graduation dispersion

The following functions have an influence on the speed graduation dispersion:

Function with or without operating control	Parameter
Speed graduation dispersion	F-119

This function sets the pedal characteristics (speed graduation from pedal position to pedal position).

Explanation of the parameter values:

- F-119 = 1 Linear speed graduation dispersion
- F-119 = 2 Slightly progressive speed graduation dispersion
- F-119 = 3 Strongly progressive speed graduation dispersion

6.1.15 Speed status

The following functions have an influence on the speed status for the free stitch and the stitch with light barrier:

Function with or without operating control	Parameter
Speed status for the free stitch and the stitch with light barrier	F-142

This function sets a certain speed characteristic for the “free stitch” and the “stitch with light barrier” sequence.

Explanation of the parameter values used:

F-142 = 0 pedal-dependant speed, controllable up to the set maximum speed (F-111).
An interruption can be done by pressing the pedal to pedal position “-2”.

6.2 Mode-dependant functions

6.2.1 Thread trimmer

6.2.1.1 Thread trimmer (mode 1, 2 and 7)

The following functions have an influence on the thread trimmer (FA):

Function with or without operating control	Parameter
Thread trimmer (FA) On/Off	F-013

This function switches the thread clipper on or off.

Note: The thread trimmer can additionally be switched on or off at the control or the V810 operating control by a “switchable function” (refer here to chapter 5.1.2 or 5.2.2 Switchable functions).

The switch status is displayed by respective light emitting diodes (LED) on the control or respective arrows on the V810 operating control:

At the control:

- by LED 5

At the V810 operating control:

- by the left arrow over the “3” button

Refer to Fig. 5, Fig. 6 + Fig. 7

Function with or without operating control	Parameter
Delay time thread trimmer (FA)	F-280

This function sets a delay time for the thread trimmer that becomes active after the sewing machine is positioned at the stitch end.

Function with or without operating control	Parameter
On-time thread trimmer (FA)	F-281

This function sets the on-time for the thread trimmer that becomes active after the thread trimmer's delay time.

6.2.1.2 Run inhibition (mode 1 and 2)

Most machine classes with thread trimmer require an additional run inhibition. This prevents the machine from starting when the thread trimmer is active or when it hasn't returned to its end position. It thereby prevents a possible collision between the thread trimmer knife and the gripper.

The run inhibition is done by a microswitch which is located on the thread trimmer.

Function with or without operating control	Parameter
Selection of the input function IN1 input at socket ST2/PIN7 - as run inhibition (LSP)	F-240

This function sets the input function (IN1 input at socket ST2/PIN7) as “run inhibition”.



CAUTION!

Setting the F-240 function should be done only during the installation of the sewing drive (refer to chapter 8.3 Installation or replacement of the sewing drive).

Set functions:

F-240 = 6 Run inhibition (LSP) effective with open contact. When the contact in the thread trimmer opens, the sewing machine stops or stays in the selected basic position.

Display after activating the run inhibition:

At the control:

- Display blinks “ A2 “

At the V810 operating control:

- Display blinks “-StoP-”

Activation of the run inhibition in the free stitch and in the stitch with stitch count:

- Stop in the basic position in the stitch
- Lifting is opened

Function with or without operating control	Parameter
Restarting after activated run inhibition (LSP)	F-234

This function sets the restarting following an effective run inhibition.

	<p style="text-align: center;">CAUTION!</p> <p>A restart of the machine following the run inhibition may be done only if the pedal was in the 0-position, i.e.</p> <p style="text-align: center;">Parameter F-234 = 1</p>
---	---

6.2.2 Trimming device (mode 1)

The following functions have an influence on the trimming device:

Function with or without operating control	Parameter
Control signal trimming device (BSV) On/Off	F-155

This function switches the control signal (ST2/PIN32) for the trimming device on or off.

Explanation of the parameter values used:

F-155 = 0 Control signal Off
The control does not give a control signal for the trimming device while the sewing machine is running.

F-155 = 1 Control signal On
The control gives a control signal for the trimming device while the sewing machine is running.

Function with or without operating control	Parameter
Switch-off delay for control signal trimming device (BSV)	F-156

This function sets a delay time for switching off the control signal for the trimming device that becomes active after the sewing machine is positioned (with pedal position " ≤ 0 ").

6.2.3 End backtack (mode 2)

The following functions have an influence on the end backtack:

Function with operating control	Parameter
Stitch number end backtack "simple"	F-002

This function sets the number of stitches for the end backtack "simple".

A backtack signal (VR to ST2/PIN34) is given by the control during the "simple" end backtack stitch sequence.

Function with operating control	Parameter
Stitch number end backtack "double"	F-003

This function sets the number of stitches for the end backtack "double".

No backtack signal (VR to ST2/PIN34) is given by the control during the "double" end backtack stitch sequence.

Function with or without operating control	Parameter
End backtack speed n4	F-113

The end backtack speed is the speed of the machine after completing the end backtack stitches.

Function with or without operating control	Parameter
Festoon stitch backtack On/Off	F-135

This function switches the festoon stitch backtack on or off.

Explanation of the parameter values:

- F-135 = 0 Festoon stitch backtack Off
The sewing machine does not stop when the backtack signal switches.
- F-135 = 1 Festoon stitch backtack On
The sewing machine stops when the backtack signal switches. The stop time can be set by parameter F-210.

Function with or without operating control	Parameter
Stop time for switching the backtack signal (VR)	F-210

This function sets a stop time for the sewing machine that becomes active when the backtack signal is switched, i.e. on and off.

The electrical backtack signal can also be clocked. This function can be used when the spool of the attached magnetic valve or magnet does not have 100% continuous duty.

A backtack signal is transmitted at the beginning of control by full drive. Afterwards there is a switch to partial drive to reduce the load on the drive and the attached spool of the magnetic valve or magnet.

Function with or without operating control	Parameter
Full drive time of the backtack signal (VR)	F-212

This function sets a full drive time for the backtack signal that becomes active after the signal is switched on.

Function with or without operating control	Parameter
Holding force (continuous duty) of the backtack signal	F-213

This function sets holding force (continuous duty) of the backtack signal.

Value	Holding force	Continuous duty
1	weak holding force	1%
100	strong holding force (full drive)	100%

	<p style="text-align: center;">CAUTION!</p> <p>If the holding force is too strong (continuous duty), then the spool or drive can be ruined.</p> <p>Be sure to observe the permissible continuous duty (ED) of the spool and set the percentile value appropriate for it.</p>
---	---

Function with or without operating control	Parameter
Upper limit (F-213) holding force of the backtack signal (VR)	F-254

This function sets the upper limit of the holding force (continuous duty) of the backtack signal that can be set in parameter F-213.

6.2.4 Thread puller (mode 7)

The following functions have an influence on the thread puller:

Function with operating control	Parameter
Thread puller (FZ) On/Off	F-014

This function switches the thread puller on or off.

Note: The thread puller can additionally be switched on or off at the control or the V810 operating control by a “switchable function” (refer here to chapter 5.2.2 Switchable functions).

The switch status is displayed by respective arrow on the V810 operating control:

At the V810 operating control:

- by the right arrow over the “3” button

Refer to Fig. 6 + Fig. 7

Function with or without operating control	Parameter
Delay time thread puller (FZ)	F-284

This function sets a delay time for the thread puller that becomes active after the sewing machine is positioned at the stitch end.

Function with or without operating control	Parameter
On-time thread puller (FZ)	F-285

This function sets the on-time for the thread puller that becomes active after the thread puller's delay time.

6.3 Additional functions of the V810 operating control

6.3.1 Machine speedometer

The following functions have an influence on the machine speedometer:

Function with operating control	Parameter
Machine speedometer On/Off	F-139

This function switches the machine speedometer on or off.

Display on the V810 operating control:

Machine speedometer = Off:

Sewing machine sequence status:

Display:

- In all sequence states
- the control type

St220A

Machine speedometer = On:

Sewing machine sequence status:

Display:

- During running:
- the current machine speed
- example: 2200 rpm

2200

- During stop in the stitch:
- the stop display

StoP

- During standstill outside of the stitch:
- the control type

St220A

6.3.2 Acoustical signal

The following functions have an influence on the acoustical signal:

Function with operating control	Parameter
Acoustical signal On/Off	F-127

This function switches the acoustical signal on or off.

The acoustical signal is given at the following functions or states:

- at activated run inhibition

7 Programming the control

7.1 General information

NOTE!

The precise parameter values can be found in the Strobel parameter list.

Parameters that are not described in the Strobel parameter list have to be reset according to the Efka parameter list on the reset values.

The values given in the parameter list, especially the setting times, are guide values that can be adapted as necessary to the machine concerned.

7.2 Operating the control without operating control

7.2.1 Access right during command entry

In order to prevent changes of preset function the entry of commands is distributed onto several levels.

Access right is given to:

- the installer at the highest level and all subsequent levels by code number 311.
- the technician at the next lower level and all subsequent levels by code number 190.
- the operator at the lowest level without code number.

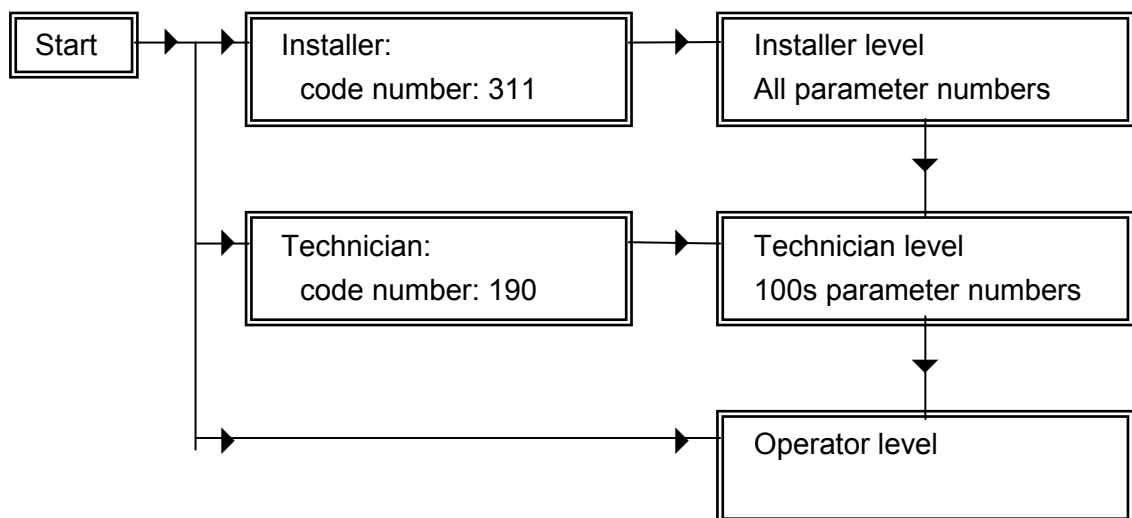

Fig. 8

7.2.2 Programming at the operator level

7.2.2.1 General information

All parameter values may be changed at the operator level without entering a code number.

Periods between the numerals in the display indicate that a parameter is being displayed. The parameter value is displayed without periods between the numerals.

The permanent transfer of the parameter values into the control's memory is done after the completed setting procedure by a brief sewing. Only then may the machine be switched off because otherwise the previously entered values are lost.

The parameter numbers shown in the illustrations may not be available in all modes. In such cases the next higher parameter number is displayed in the display.

7.2.2.2 Call up and change parameters one after the other

1. Switch on main switch S0.
Machine speed is displayed:

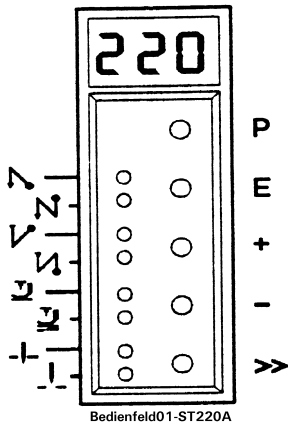

2. Press "P" button.

Parameter "000" is displayed:

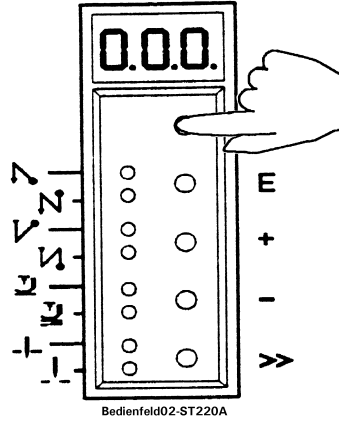

3. Press "+" button, not in mode 2.

First parameter is displayed:

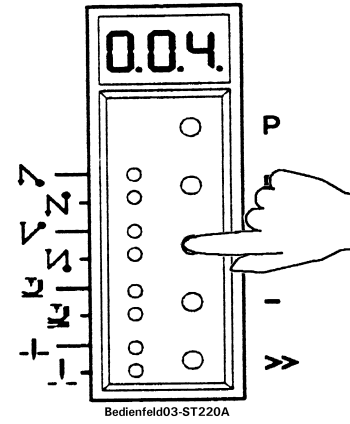

4. Press "E" button.

Parameter value is displayed:

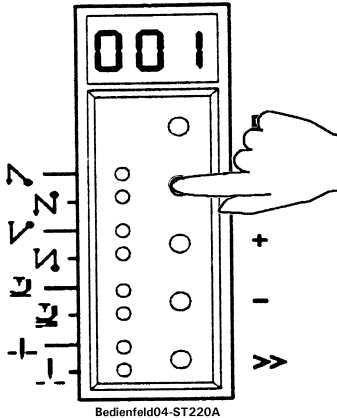

5. Press "+/-" button; here "+" button.

Parameter value is changed:

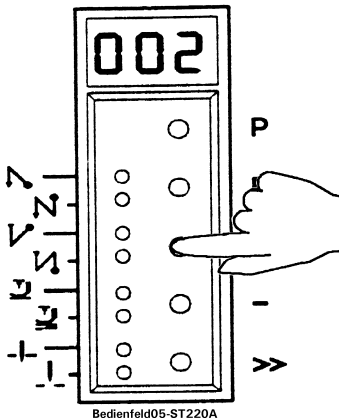

6. Press "E" button.

Next parameter is displayed:

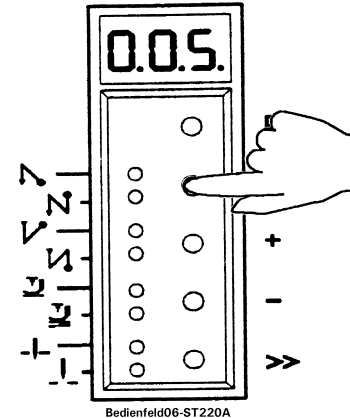

7. Press "P" button.

Same parameter is displayed:

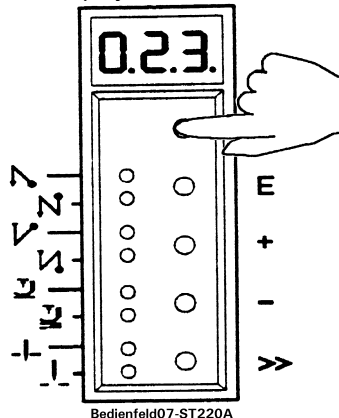

8. Press "P" button.

Machine speed is displayed:

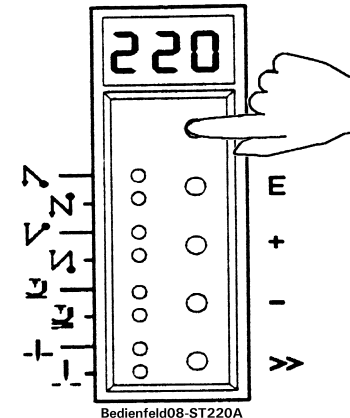

In this way all parameters can be called up at the programming level to be changed. After the last parameter value the programming at the programming level has to be exited as follows:

7.2.2.3 Call up and change parameters directly

1. Switch on main switch S0. Machine speed is displayed:
2. Press "P" button.
3. Press ">>" button.

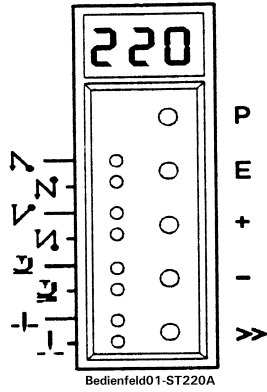

Display is:

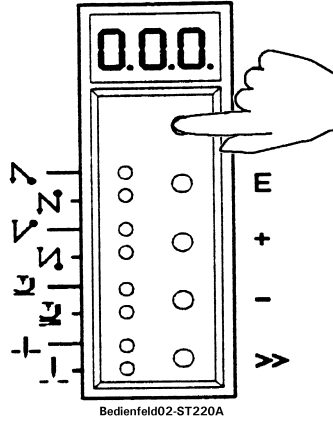

First digit blinks:

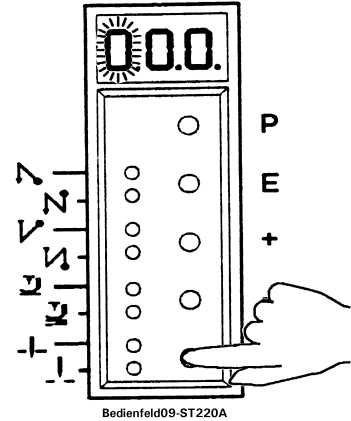

4. Press ">>" button.
Second digit blinks:

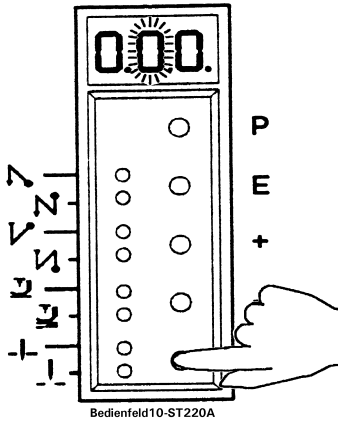

5. Press "+/-" button; in this case the "+" button. Numerical value of the digit is changed:

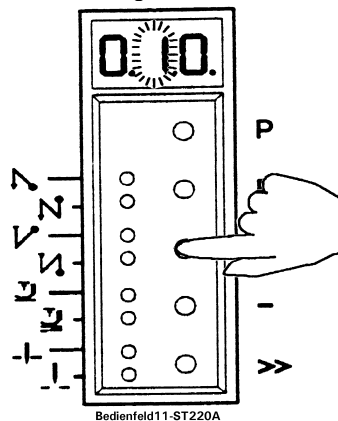

6. Press ">>" button.
Third digit blinks:

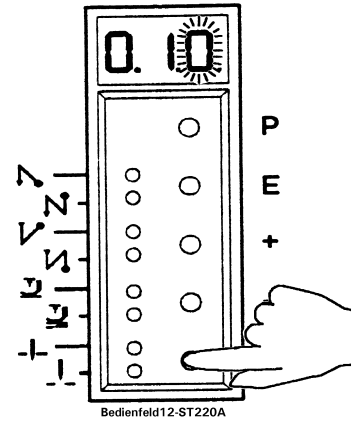

7. Press "+/-" button; in this case the "+" button 3 times. Numerical value of the digit is changed:

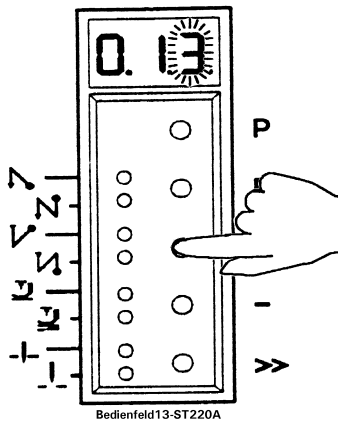

8. Press "E" button.
Parameter value is displayed:

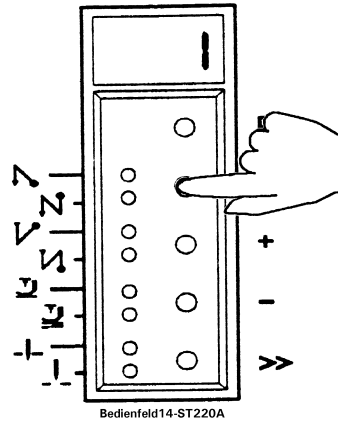

9. Press "+/-" button; in this case the "-" button. Parameter value is changed:

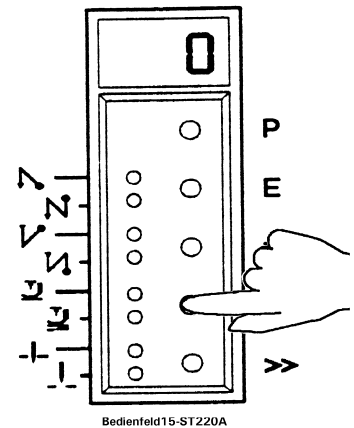

By pressing the "E" button the next parameter can be called up right after the direct setting. By pressing the ">>" button a new parameter can then be called up directly. After changing the last parameter value the programming at the programming level has to be exited as follows:

10. Press "P" button.

Same parameter is displayed:

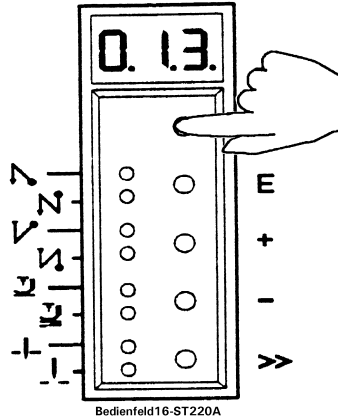

11. Press "P" button.

Machine speed is displayed:

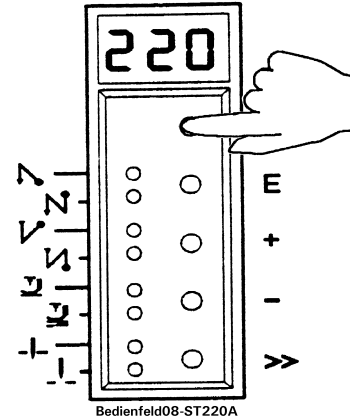

7.2.2.4 Call up and change parameters by pressing the "+/-" buttons

1. Switch on main switch S0.

2. Press "P" button.

3. Press "+/-" button; in this case the "+" button 2 times. Parameter is displayed:

Machine speed is displayed:

Parameter "000" is displayed:

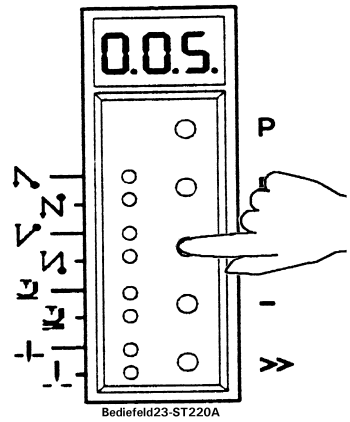
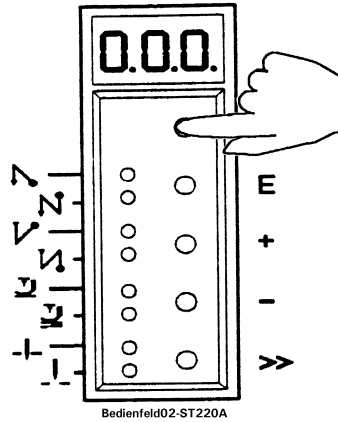
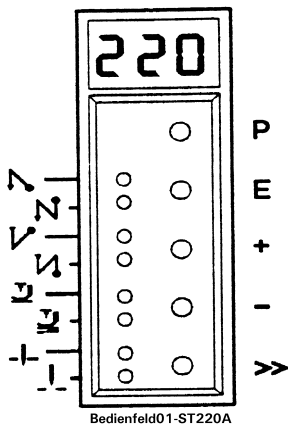

4. Press "E" button.

5. Press "+/-" button; in this case the "+" button. Parameter is changed:

6. Press "E" button.

Parameter value is displayed:

Next parameter is displayed:

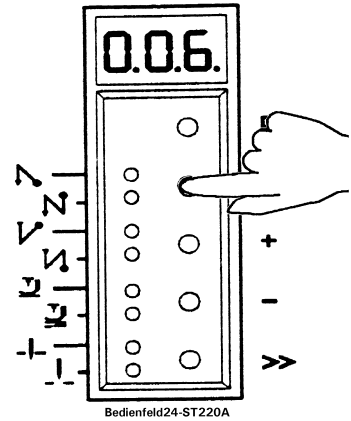
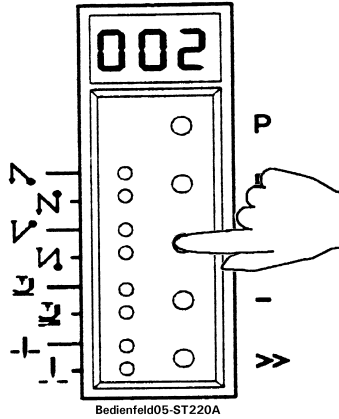
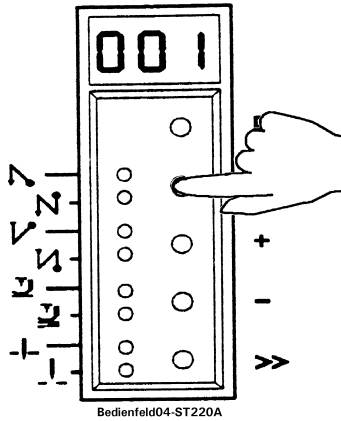

7. Press "+/-" button; in this case the "-" button 2 times. Parameter is displayed:

8. Press "E" button. Parameter value is displayed:

9. Press "+/-" button; in this case the "+" button. Parameter value is changed:

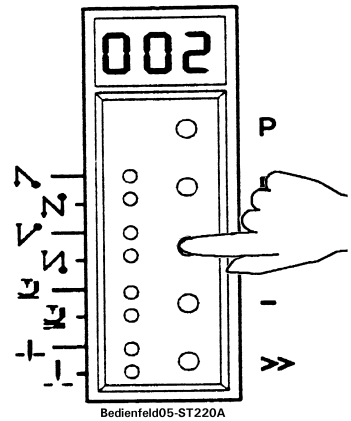
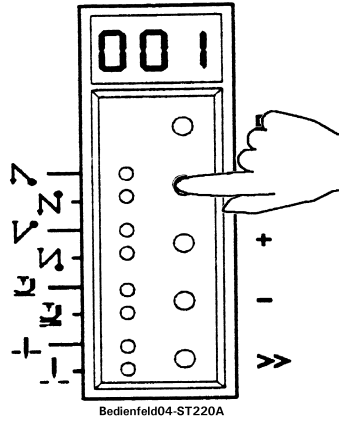
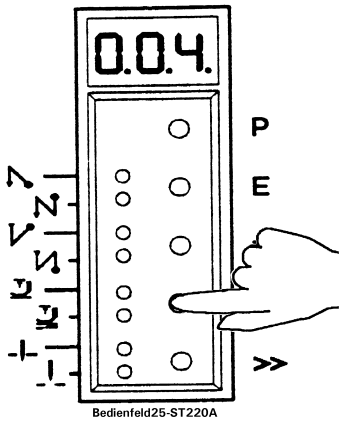

10. Press "P" button.

11. Press "P" button.

The same parameter value is displayed:

Machine speed is displayed:

In this way all parameters can be called up at will and changed at the programming level. After changing the last parameter value the programming at the programming level has to be exited as follows:

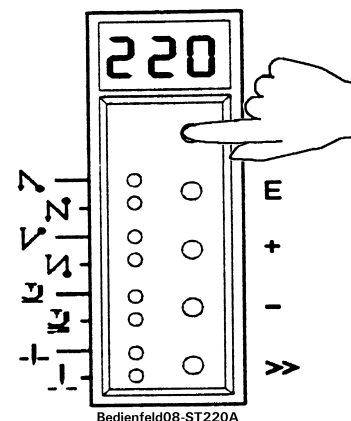
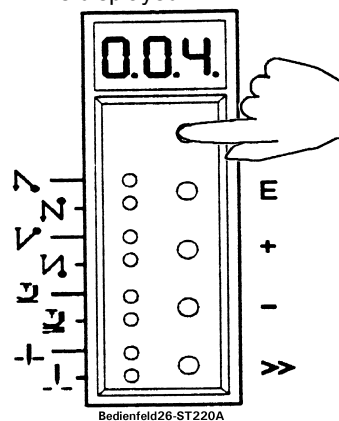

7.2.3 Programming at the technician or installer level

7.2.3.1 General information

The parameter values can be changed at the technician or installer level only when a code number has been entered.

Code number at the technician level	=>	190
Code number at the installer level	=>	311

Periods between the numerals in the display indicate that a parameter is being displayed. The parameter value is displayed without periods between the numerals.

The permanent transfer of the parameter values into the control's memory is done after the completed setting procedure by a brief sewing. Only then may the machine be switched off because otherwise the previously set values are lost.

The parameter numbers shown in the illustrations may not be available in all modes. In such cases the next higher parameter number is displayed in the display.



CAUTION!

Changing the parameter values at the technician or installer level has to be done very carefully because a faulty setting can damage the control or the sewing machine.

7.2.3.2 Programming the code number

for example the code number "190" for the technician level

1. Press the "P" button and the S0 main switch at the same time.
Display is:
2. Press ">>" button.

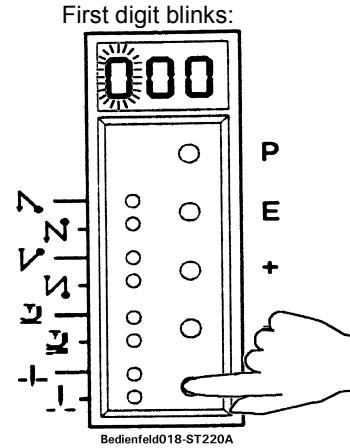
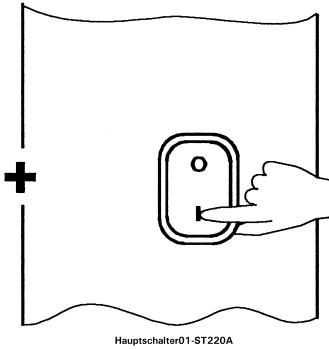
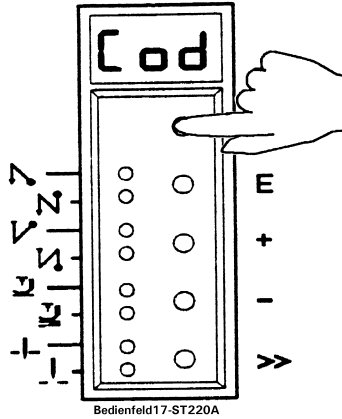

3. Press "+/-" button; in this case the "+" button.
Numerical value of the digit is changed:

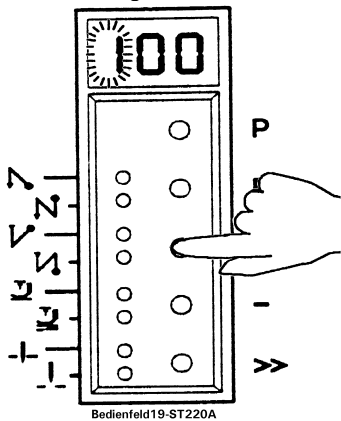

4. Press ">>" button.
Second digit blinks:

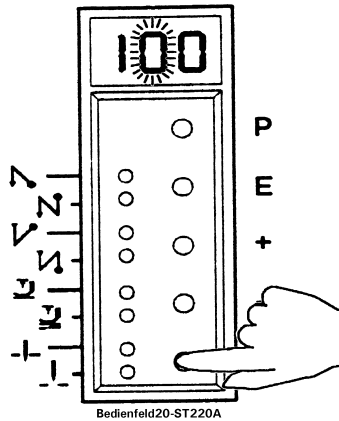

5. Press "+/-" button; in this case the "-" button.
Numerical value of the digit is changed:

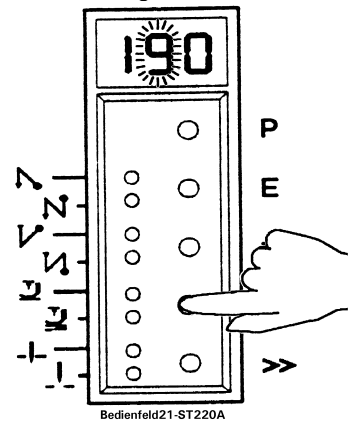

6. Press "E" button.

the first parameter at the technician level is displayed:

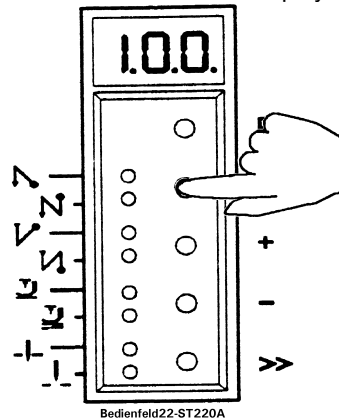

By pressing the ">>" button the third digit can be selected if necessary and changed by pressing the "+/-" button:

7.2.3.3 Call up and change parameters one after the other

1. After entering the code number.
First parameter is displayed:
2. Press "E" button.
Parameter value is displayed:
3. Continue as described in chapter 7.2.2.2 "Call up and change parameters one after the other" as of step 5.

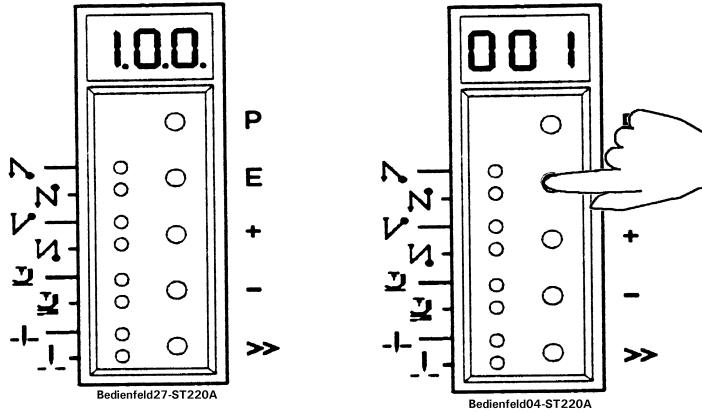

7.2.3.4 Call up and change parameters directly

1. After entering the code number.
First parameter is displayed:
2. Press ">>" button.
First digit blinks:
3. Press ">>" button.
Second digit blinks:

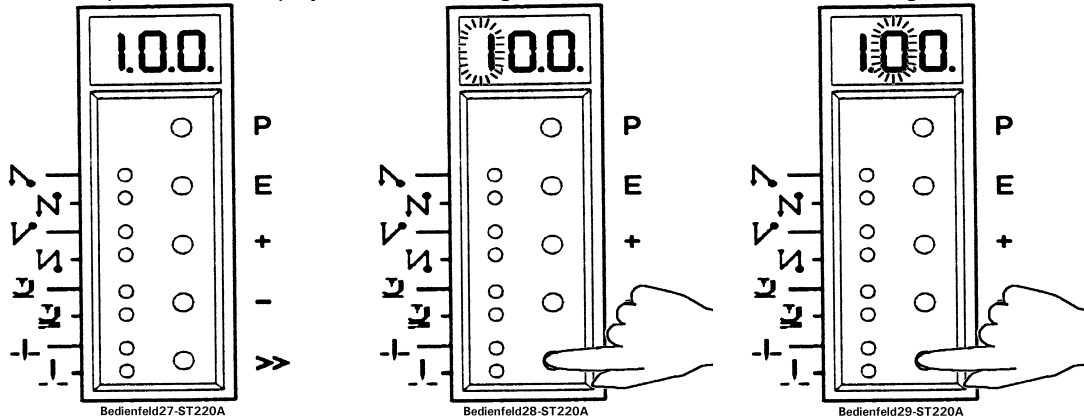

4. Continue as described in chapter 7.2.2.3 "Call up and change parameters directly" as of step 5.

7.2.3.5 Call up and change parameters by pressing the “+/-” buttons

1. After entering the code number.
First parameter is displayed:
2. Press “+” button.
Next parameter is displayed:
3. Continue as described in chapter 7.2.2.4 “Call up and change parameters by pressing the “+/-” buttons”.
as of step 4

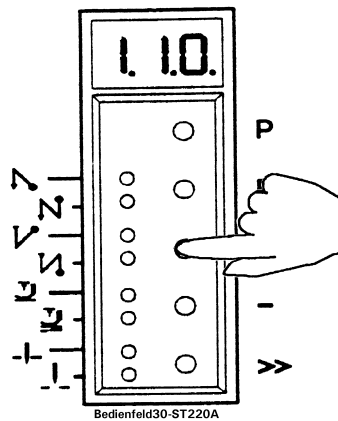
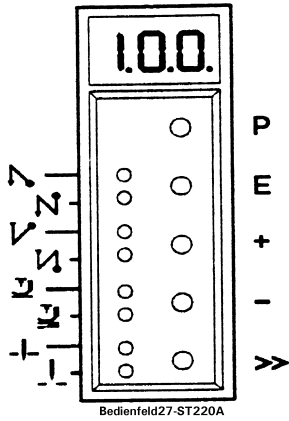

7.2.4 Setting the positions

7.2.4.1 General information

The individual positions of the machine (machine positions) can be found in the operating manual of the sewing machine.

NOTE!

For sewing machines that actually need only one position, both positions always need to be programmed anyway for the control programming. This is because the needle does have to be positioned somewhere following a change in display in **observance** of the notes in chapter **6.1.5 Positions**.

The setting of the positions can be easily checked using the F-172 function. Refer to chapter 8.1.1 Display of the needle position.

7.2.4.2 Setting the reference position

After entering the code number "190" for the technician level:

- | | | |
|---------------------------|----------------|-------|
| - Select parameter F-170. | Display shows: | 1.7.0 |
| - Press "E" button. | | Sr1 |
| - Press ">>" button. | | P I_ |

Turn the handwheel in the machine's direction of rotation until the circulation symbol disappears from the display. Set the handwheel or needle to the sewing machine's reference position (see operating manual of the sewing machine).

- | | |
|---|-------|
| - Press "E" button. | 1.7.1 |
| - Exit the programming level by pressing the "P" button | |

or

continue with chapter 7.2.4.3 "Setting the positions 1 and 2" as of step 2.

7.3 Operating the control with the V810 operating control

7.3.1 Access right during command entry

In order to prevent changes of preset function the entry of commands is distributed onto several levels.

Access right is given to:

- the installer at the highest level and all subsequent levels by code number 3112.
- the technician at the next lower level and all subsequent levels by code number 1907.
- the operator at the lowest level without code number.

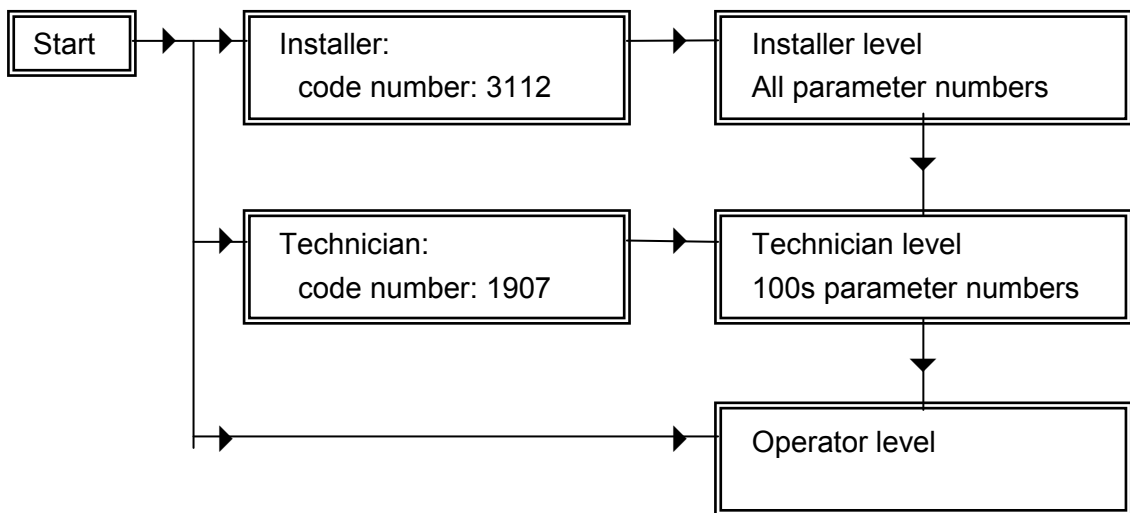

Fig. 9

7.3.2 Programming at the operator level

7.3.2.1 General information

All parameter values may be changed at the operator level without entering a code number.

The string “F-” in the display indicates that a parameter is being displayed. Parameter values are displayed without the string “F-”.

Parameter values changed at the operator level are saved immediately upon exiting the programming level.

The parameter numbers shown in the illustrations may not be available in all modes. In such cases the next higher parameter number is displayed in the display.

7.3.2.2 Call up and change parameters one after the other

1. Switch on main switch S0.
The control type is displayed:

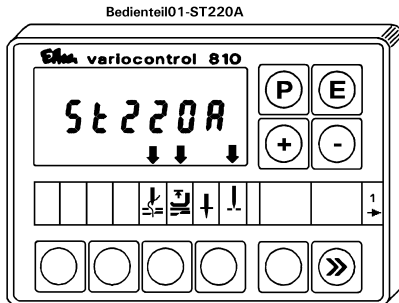

2. Press "P" button.
Parameter "000" is displayed:

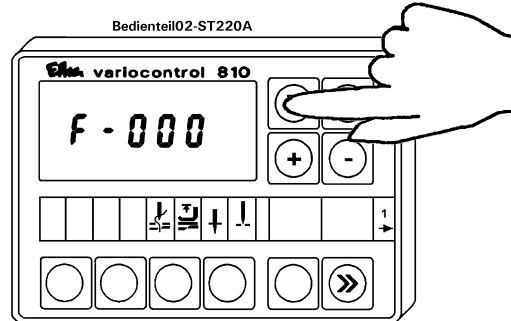

3. Press "+" button, not in mode 2.
First parameter is displayed:

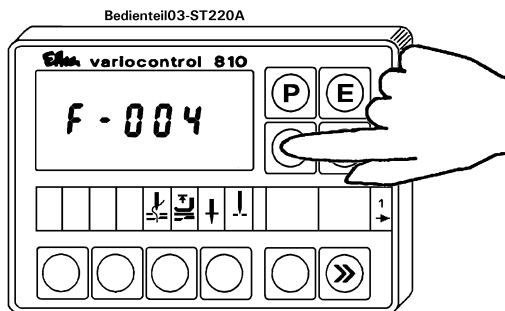

4. Press "E" button.
Parameter value is displayed:

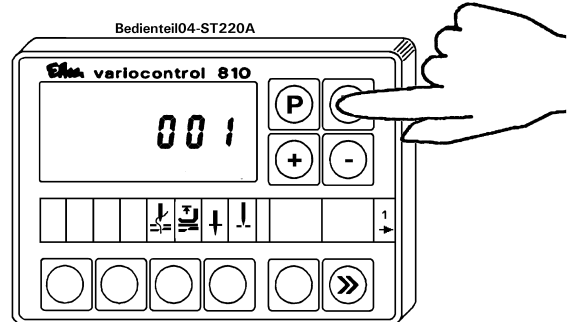

5. Press "+/-" button; in this case the "+" button.
Parameter value is changed:

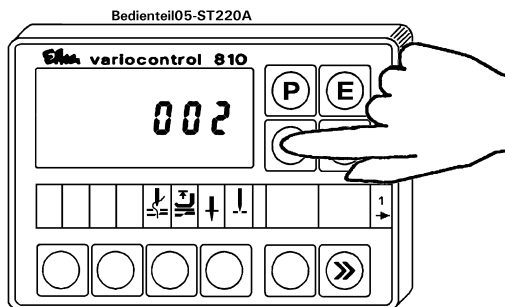

6. Press "E" button.
Next parameter is displayed:

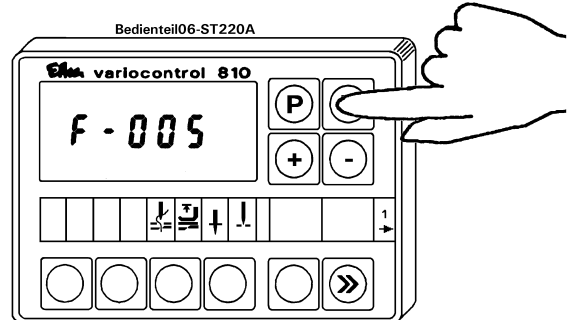

7. Press "P" button.
Same parameter is displayed:

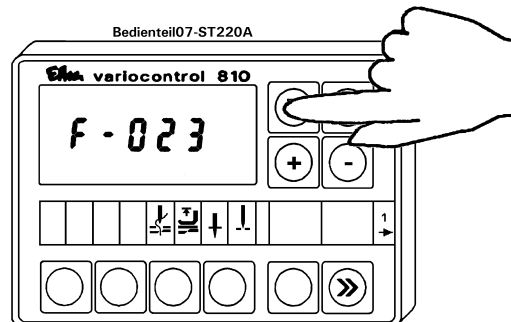

In this way all parameters can be called up at the programming level to be changed. After the last parameter value the programming at the programming level has to be exited as follows:

8. Press "P" button.
Machine speed is displayed for about 2 sec.:

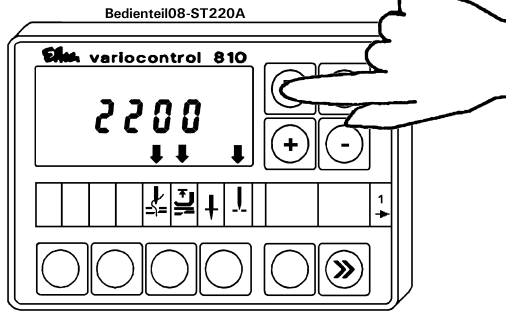

9. The control type is displayed:

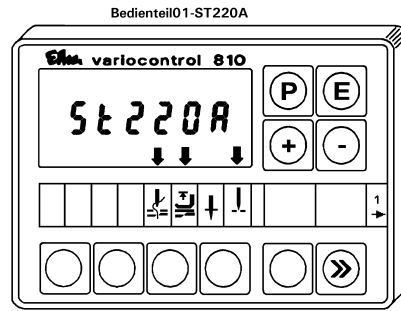

7.3.2.3 Call up and change parameters directly

1. Switch on main switch S0.
The control type is displayed:

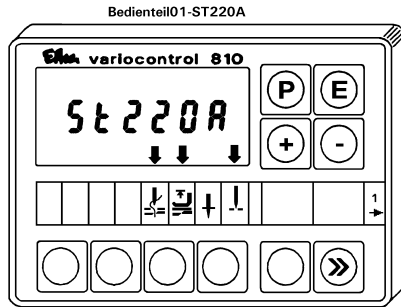

2. Press "P" button.
Parameter "000" is displayed:

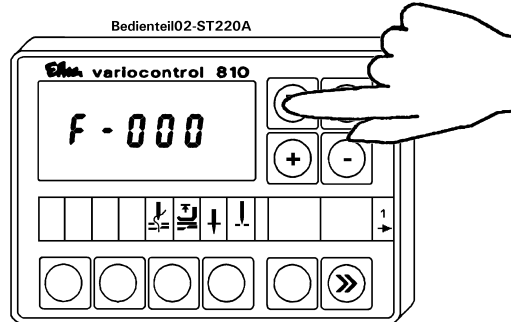

3. Press ">>" button.
First digit blinks:

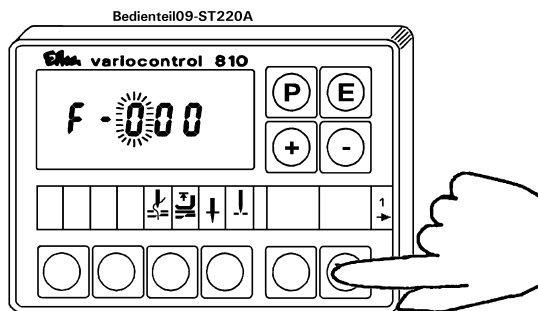

4. Press ">>" button.
Second digit blinks:

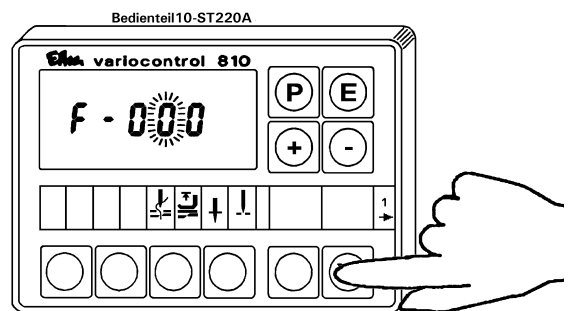

5. Press "+/-" button; in this case the "+" button.
Numerical value of the digit is changed:

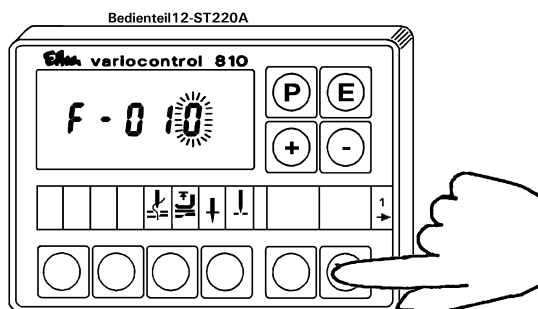

6. Press ">>" button.
Third digit blinks:

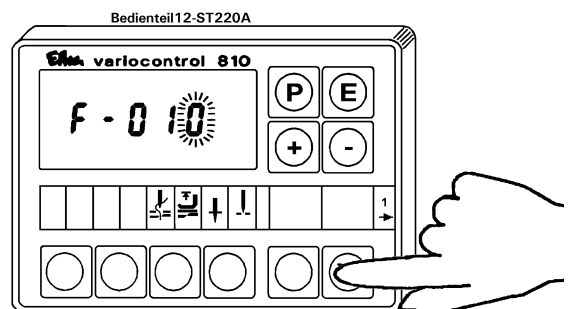

7. Press “+/-” button; in this case the “+” button 3 times.
Numerical value of the digit is changed:

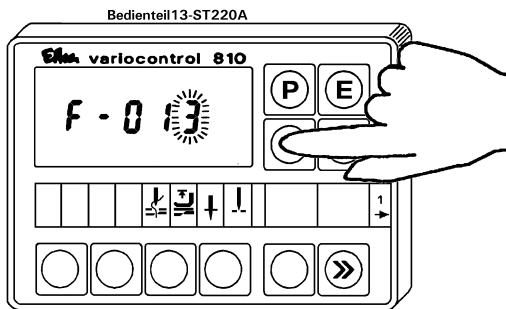

8. Press “E” button.
Parameter value is displayed:

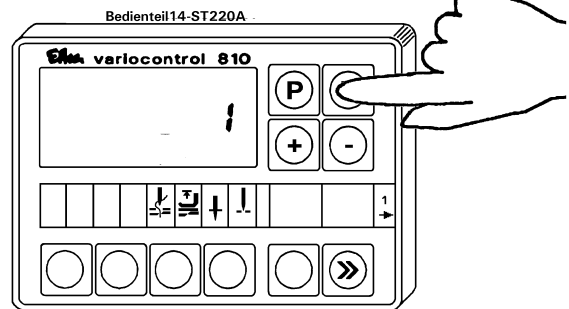

9. Press “+/-” button; in this case the “-” button.
Numerical value of the digit is changed:

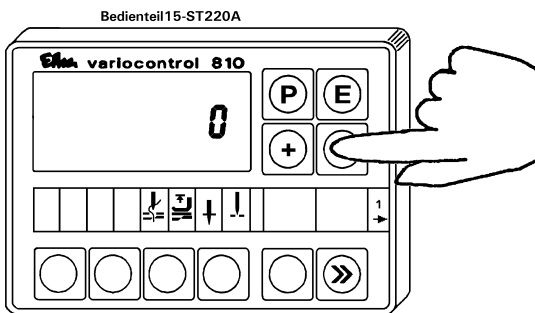

By pressing the “E” button the next parameter can be called up right after the direct setting. By pressing the “>>” button a new parameter can then be called up directly. After changing the last parameter value the programming at the programming level has to be exited as follows:

10. Press “P” button.
Same parameter is displayed:

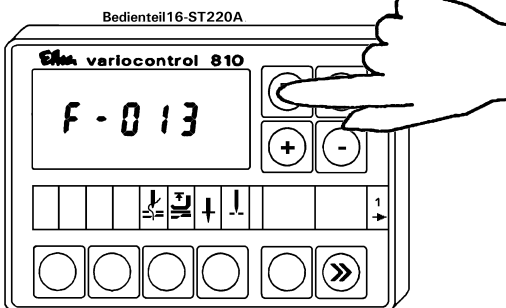

11. Press “P” button.
Machine speed is displayed for about 2 sec.:

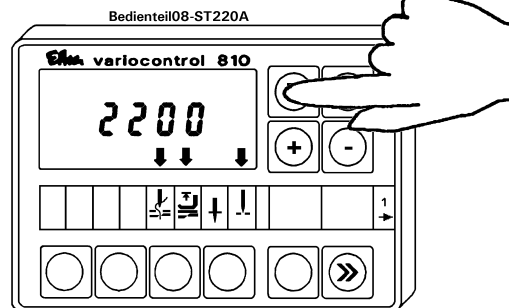

12. The control type is displayed:

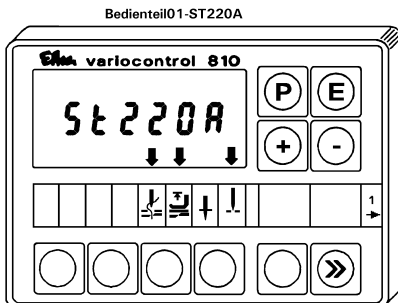

7.3.2.4 Call up and change parameters by pressing the “+/-” buttons

1. Switch on main switch S0.
The control type is displayed:

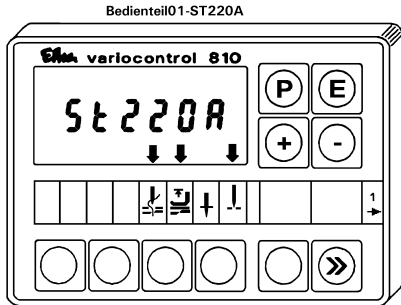

2. Press “P” button.
Parameter “000” is displayed:

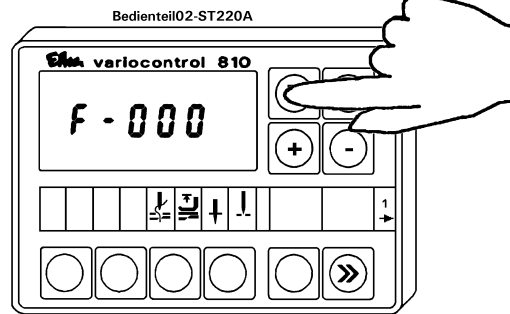

3. Press “+/-” button; in this case the “+” button 2 times.
Parameter is displayed:

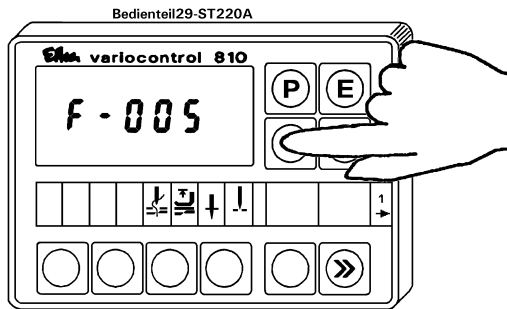

4. Press “E” button.
Parameter value is displayed:

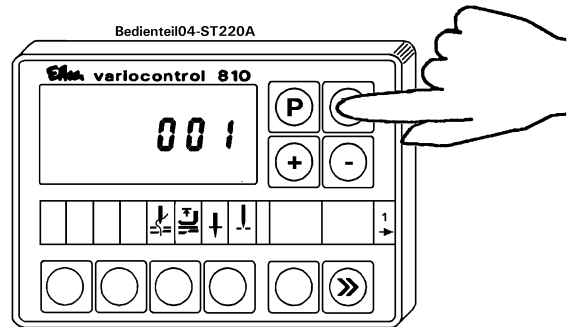

5. Press “+/-” button; in this case the “+” button.
Parameter value is changed:

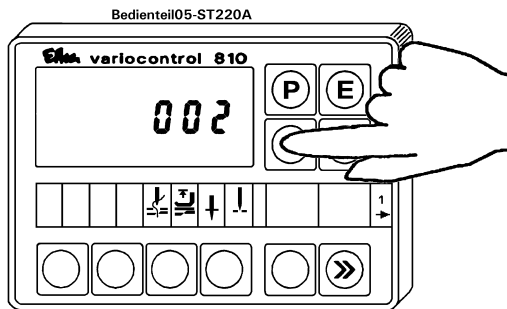

6. Press “E” button.
Parameter value is displayed:

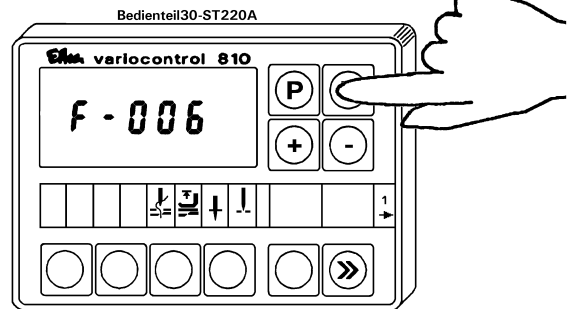

7. Press “+/-” button; in this case the “-” button 2 times.
Parameter is displayed:

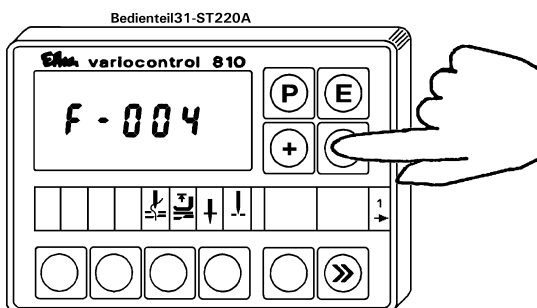

8. Press “E” button.
Parameter value is displayed:

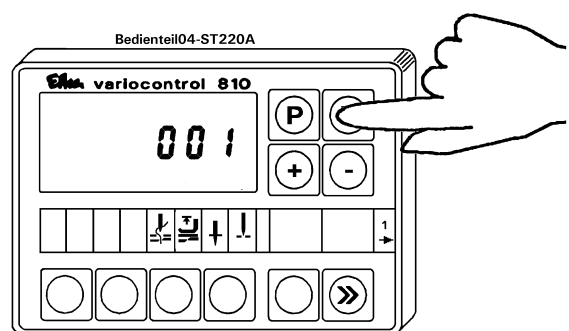

9. Press "+/-" button; in this case the "+" button.
Parameter value is changed:

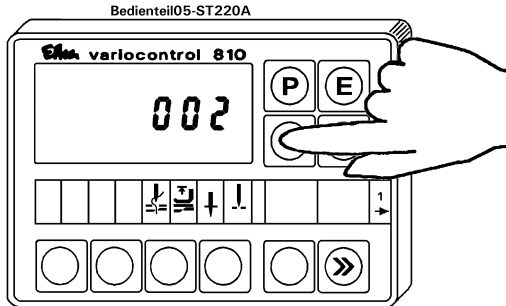

In this way all parameters can be called up at will and changed at the programming level. After changing the last parameter value the programming at the programming level has to be exited as follows:

10. Press "P" button.
Same parameter is displayed:

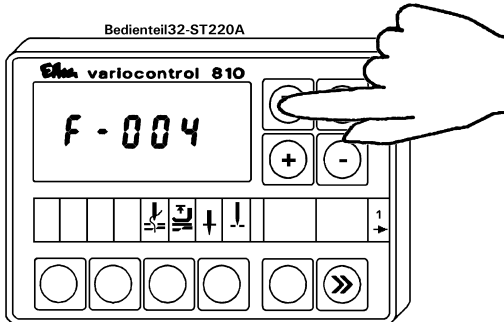

11. Press "P" button.
Machine speed is displayed for about 2 sec.:

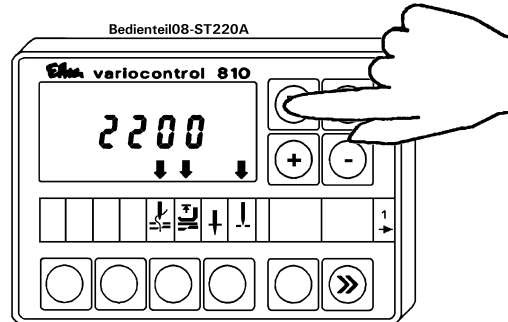

12. The control type is displayed:

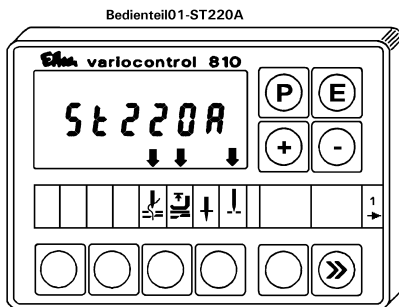

7.3.3 Programming at the technician or installer level

7.3.3.1 General information

The parameter values can be changed at the technician or installer level only when a code number has been entered.

Code number at the technician level => 1907
Code number at the installer level => 3112

The string "F-" in the display indicates that a parameter is being displayed. Parameter values are displayed without the string "F-".

Parameter values changed at the technician or installer level are saved immediately upon exiting the programming level.

The parameter numbers shown in the illustrations may not be available in all modes. In such cases the next higher parameter number is displayed in the display.



CAUTION!

Changing the parameter values at the technician or installer level has to be done very carefully because a faulty setting can damage the control or the sewing machine.

7.3.3.2 Programming the code number

for example the the code number “1907” for the technician level

1. Press the “P” button and the S0 main switch at the same time. Display is:

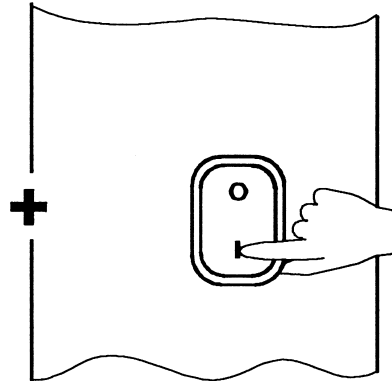
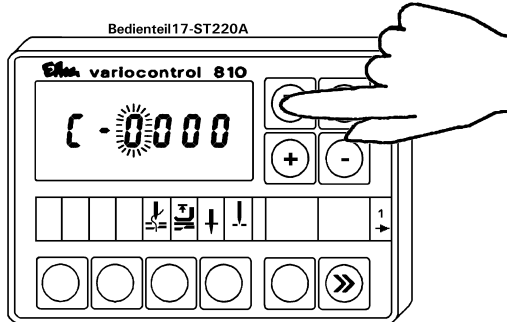

2. Press “+/-” button; in this case the “+” button. Numerical value of the digit is changed:
3. Press “>>” button. Second digit blinks:

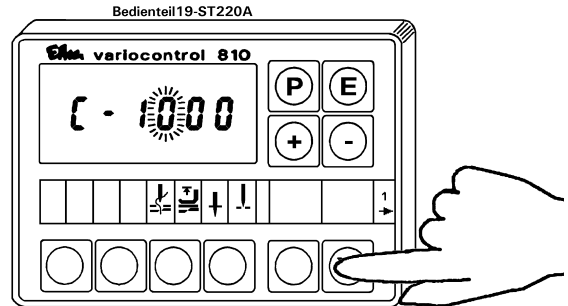
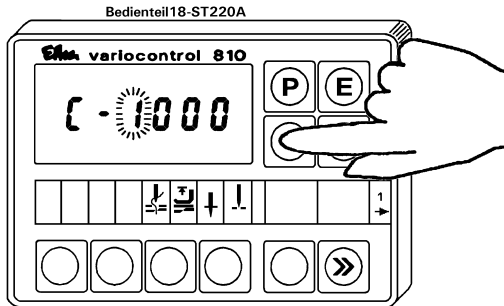

4. Press “+/-” button; in this case the “-” button. Numerical value of the digit is changed:
5. Press “>>” button. Third digit blinks:

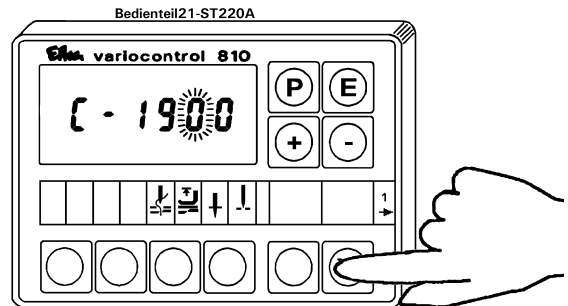
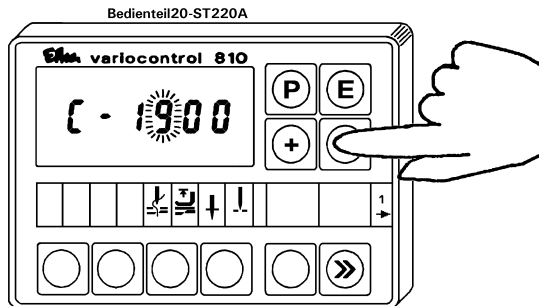

6. Press “>>” button. Forth digit blinks:
7. Press “+/-” button; in this case the “-” button 3 times. Numerical value of the digit is changed:

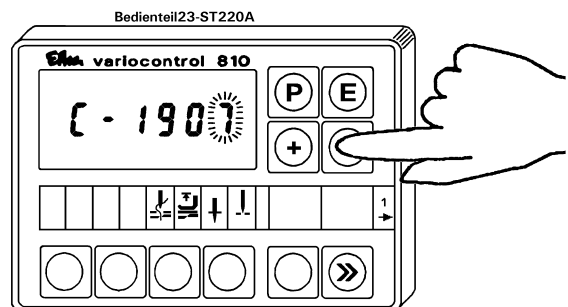
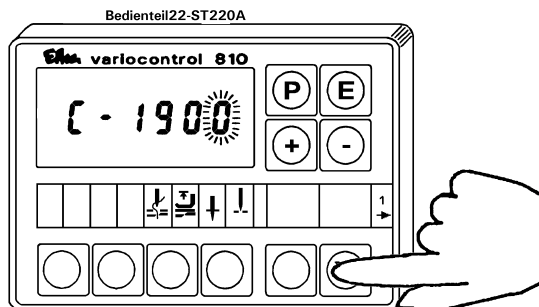

8. Press "E" button.
The first parameter at the technician level is displayed:

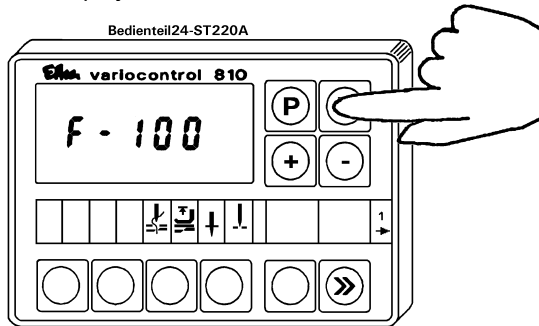

7.3.3.3 Call up and change parameters one after the other

1. After entering the code number.
First parameter is displayed:
2. Press "E" button.
Parameter value is displayed:

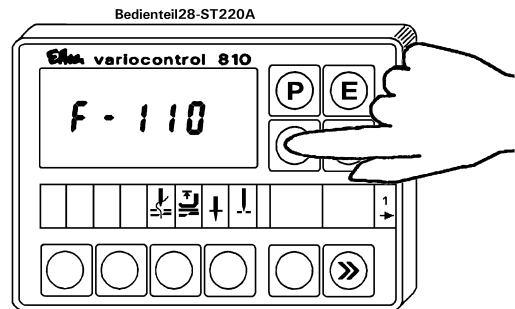
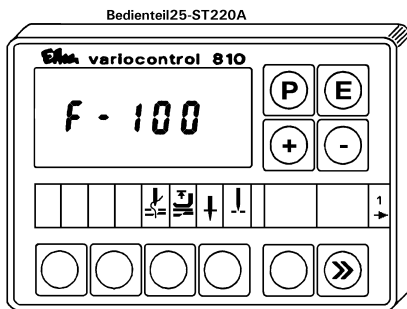

3. Continue as described in chapter 7.3.2.2
"Call up and change parameters one after the other" as of step 5.

7.3.3.4 Call up and change parameters directly

1. After entering the code number.
First parameter is displayed:

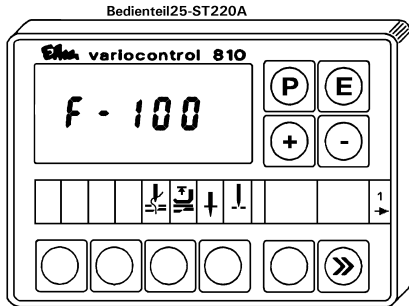

2. Press ">>" button.
First digit blinks:

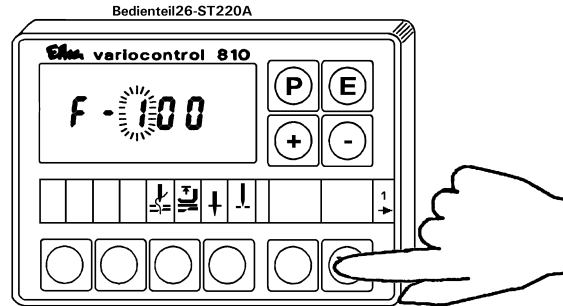

3. Press ">>" button.
Second digit blinks:

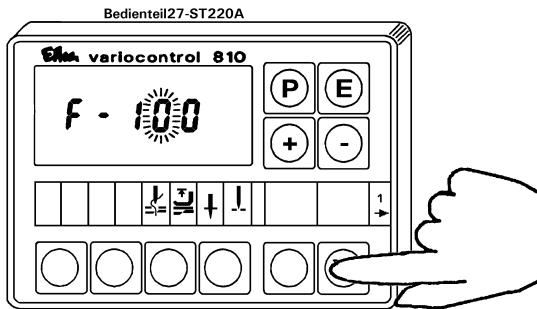

4. Continue as described in chapter 7.3.2.3 "Call up and change parameters directly" as of step 5.

7.3.3.5 Call up and change parameters by pressing the "+/-" buttons

1. After entering the code number.
First parameter is displayed:

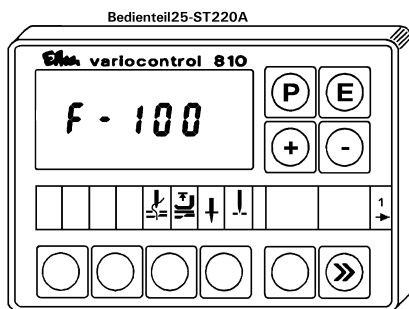

2. Press "+" button.
Next parameter is displayed:

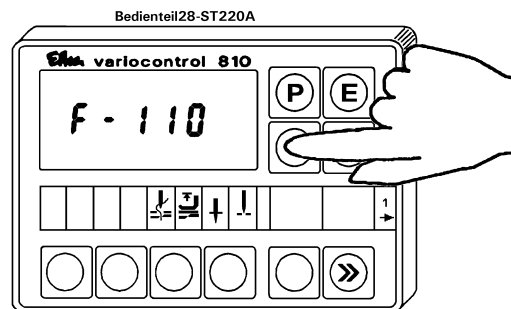

3. Continue as described in chapter 7.3.2.4 "Call up and change parameters by pressing the "+/-" buttons" as of step 4.

7.3.4 Setting the positions

7.3.4.1 General information

The individual positions of the sewing machine (machine positions) can be found in the operating manual of the sewing machine.

NOTE!

For sewing machines that actually need only one position, both positions always need to be programmed anyway for the control programming. This is because the needle does have to be positioned somewhere following a change in display in **observance** of the notes in chapter **6.1.5 Positions**.

The setting of the positions can be easily checked using the F-172 function. Refer to chapter 8.2.1 Display of the needle positions.

7.3.4.2 Setting the reference position

After entering the code number "1907" for the technician level:

- Select parameter F-170. Display shows: F-170
- Press "E" button. Sr1[°]
- Press ">>" button. PoS0 □

Turn the handwheel in the machine's direction of rotation until the circulation symbol disappears from the display. Set the handwheel or needle to the sewing machine's reference position (see operating manual of the sewing machine).

- Press "E" button. F-171
- Exit the programming level by pressing the "P" button

or

continue with chapter 7.3.4.3 "Setting the positions 1 and 2" as of step 2.

7.3.4.3 Setting positions 1 and 2

After entering the code number "1907" for the technician level:

- Select parameter F-171. Display shows: F-171
- Press "E" button. Sr2[°]
- Press ">>" button. P1Exxx

Turn the handwheel in the machine's direction of rotation until the position value in the display changes. Then set the handwheel or needle to the position 1 of the sewing machine (see operating manual of the sewing machine).

- Press "E" button. Display shows: P2Exxx

Turn the handwheel in the machine's direction of rotation until the position value in the display changes. Then set the handwheel or needle to the position 2 of the sewing machine (see operating manual of the sewing machine).

- Press "E" button. Display shows: P1Axxx

Turn the handwheel in the machine's direction of rotation until the position value in the display changes. Then turn the handwheel until the position value "P1E + 25" is displayed.

- Press "E" button. P2Axxx

Turn the handwheel in the machine's direction of rotation until the position value in the display changes. Then turn the handwheel until the position value "P2E + 25" is displayed.

- Press "P" button. F-171
- Press "P" button.

8 Service

8.1 Operating without operating control

8.1.1 Display of the needle positions

Function without operating control	Parameter
Display of the Positions 1 and 2 (down / up)	F-172

The setting of the positions can be easily checked using this function.

After entering the code number "190" for the technician level:

- Select parameter F-172. Display shows: 1.7.2
- Press "E" button. Sr3
- Turn handwheel according to the motor's direction of rotation.

Display on the control:

LED7 is switched on ⇒ Position 1E

LED7 is switched off ⇒ Position 1A

LED8 is switched on ⇒ Position 2E

LED8 is switched off ⇒ Position 2A

- Press "P" button. 1.7.2
- Press "P" button.

8.1.2 Display of the program number

Function without operating control	Parameter
Display of the program number with index and identification number.	F-179

This function displays of the program number of the control with index and identification number.

Example: Program No.: 5380A
Identification No.: 01080113

After entering the code number "190" for the technician level:

- Select parameter F-179. Display shows: 1.7.9
- Press "E" button. Sr5
- Press ">>" button. 53
- Press "E" button. 80
- Press "E" button. 8
- Press "E" button. 01
- Press "E" button. 08
- Press "E" button. 01
- Press "E" button. 13
- Press "P" button. 1.7.9
- Press "P" button.

8.1.3 Signal test

8.1.3.1 General information

Function without operating control	Parameter
Test of the signal in- and outputs	F-173

The external inputs and the transistor power outputs with the connected actuators (e.g. magnetic valves) can easily be checked by this function.

The sewing machine can not be started during the test.

8.1.3.2 Test of the signal outputs (general)

The following functions have an influence on the end test of the signal outputs:

Function without operating control	Parameter
Type of activation of the outputs during the output test with parameter F-173	F-806

This function sets the type of activation of the outputs during the output test with parameter F-173.

Explanation of the parameter values:

- F-806 = 0 Activate outputs with ">>" button.
- F-806 = 1 Activate outputs with ">>" button or with "-2" pedal position.

The signal outputs can be tested as follows:

After entering the code number "190" for the technician level:

- Select parameter F-173. Display shows: 1.7.3
- Press "E" button. oFF
- Press the "+/-" buttons to select the desired output (see table).

Display	Mode	Output assignments
iXX/oFF	all	input test
01	2	backtack (backtack signal)
02	1, 2	lifting
03	1, 2	thread trimmer
04	not assigned	
05	1, 2	thread trimmer
06-13	not assigned	

- Press ">>" button - activate selected output. XX
- Press "P" button. 1.7.3
- Press "P" button.

8.1.3.3 Test of the signal inputs (general)

The signal inputs can be tested as follows:

After entering the code number "190" for the technician level:

- Select parameter F-173. Display shows: 1.7.3
- Press "E" button. oFF
- Press input to be tested manually. iXX

Since all external inputs are monitored simultaneously by the control, only the input to be tested may therefore be activated during a test. Any further activated input will not be recognised or rather only the lowest activated input will be recognised. The activated input is displayed (see table).

Display	Mode	Input assignments
oFF	all	All inputs not activated
i01	1, 2	Run inhibition in thread trimmer (FA) activated

- Press "P" button. 1.7.3
- Press "P" button.

8.1.3.4 Test of the run inhibition in thread trimmer (mode 1 and 2)

The run inhibition in the thread trimmer (microswitch) can be tested as follows:

After entering the code number "190" for the technician level:

- Select parameter F-173. Display shows: 1.7.3
- Press "E" button. oFF
- "i01" is displayed continuously:
 - microswitch in the thread trimmer is adjusted wrong.
 - microswitch in the thread trimmer is defective.
 - line between microswitch and control interrupted.
- Press thread trimmer manually.
- Display changes from "oFF" to "i01":
 - Function of the run inhibition in the thread trimmer is OK.
- Display remains "oFF":
 - microswitch in the thread trimmer is adjusted wrong.
 - microswitch in the thread trimmer is defective.
- Press "P" button. 1.7.3
- Press "P" button.

8.1.3.5 Manual control signal, trimming device (mode 1)

Manual control signal for trimming device by pedal position "-2" for service tasks:

Prerequisite:

Parameter F-806 = 1

After entering the code number "190" for the technician level:

- Select parameter F-173. Display shows: 1.7.3
- Press "E" button. oFF
- Press "+" button 7 times. 07
- Switch trimming device on and off with pedal.
 - Pedal in pedal position "≥0"
 - Trimming device is switched off.
 - Pedal in pedal position "-2"
 - Trimming device is switched on.
- Press "P" button. 1.7.3
- Press "P" button.

8.2 Operating with the V810 operating control

8.2.1 Display of the needle positions

Function with V810 operating control	Parameter
Display of the Positions 1 and 2 (down / up)	F-172

The setting of the positions can be easily checked using this function.

After entering the code number "1907" for the technician level:

- Select parameter F-172. Display shows: F-172
- Press "E" button. Sr3
- Turn handwheel according to the motor's direction of rotation.

Display on the V810 operating control:

left arrow over the "4" button
is switched on ⇒ Position 1E

left arrow over the "4" button
is switched off ⇒ Position 1A

right arrow over the "4" button
is switched on ⇒ Position 2E

right arrow over the "4" button
is switched off ⇒ Position 2A

- Press "P" button. F-172
- Press "P" button.

8.2.2 Display of the program number

Function with operating control	Parameter
Display of the program number with index and identification number.	F-179

This function displays of the program number of the control with index and identification number.

Example: Program No.: 5380A
Identification No.: 01080113

After entering the code number "1907" for the technician level:

- | | | |
|---------------------------|----------------|-------|
| - Select parameter F-179. | Display shows: | F-179 |
| - Press "E" button. | Sr5[°] | |
| - Press ">>" button. | | 5380A |
| - Press "E" button. | 010801 | |
| - Press "E" button. | 13 | |
| - Press "E" button. | 01 | |
| - Press "P" button. | F-179 | |
| - Press "P" button. | | |

8.2.3 Signal test

8.2.3.1 General information

Function with operating control	Parameter
Test of the signal in- and outputs	F-173

The external inputs and the transistor power outputs with the connected actuators (e.g. magnetic valves) can easily be checked by this function.

The sewing machine can not be started during the test.

8.2.3.3 Test of the signal inputs (general)

The signal inputs can be tested as follows:

After entering the code number "1907" for the technician level:

- Select parameter F-173. Display shows: F-173
- Press "E" button. oFF
- Press input to be tested manually. iXX

Since all external inputs are monitored simultaneously by the control, only the input to be tested may therefore be activated during a test. Any further activated input will not be recognised or rather only the lowest activated input will be recognised. The activated input is displayed (see table).

Display	Mode	Input assignments
oFF	all	All inputs not activated
i01	1, 2	Run inhibition in thread trimmer (FA) activated

- Press "P" button. F-173
- Press "P" button.

8.2.3.4 Test of the run inhibition in thread trimmer (mode 1 and 2)

The run inhibition in the thread trimmer can be tested as follows:

After entering the code number "1907" for the technician level:

- Select parameter F-173. Display shows: F-173
- Press "E" button. oFF
- "i01" is displayed continuously:
 - microswitch in the thread trimmer is adjusted wrong.
 - microswitch in the thread trimmer is defective.
 - line between microswitch and control interrupted.
- Press thread trimmer manually.
- Display changes from "oFF" to "i01":
 - Function of the run inhibition in the thread trimmer is OK.
- Display remains "oFF":
 - microswitch in the thread trimmer is adjusted wrong.
 - microswitch in the thread trimmer is defective.
- Press "P" button. F-173
- Press "P" button.

8.2.3.5 Manual control signal, trimming device (mode 1)

Manual control signal for trimming device by pedal position "-2" for service tasks:

Prerequisite:

Parameter F-806 = 1

After entering the code number "1907" for the technician level:

- Select parameter F-173. Display shows: F-173
- Press "E" button. oFF
- Press "+" button 7 times. 07
- Switch trimming device on and off with pedal.
 - Pedal in pedal position "≥0"
 - Trimming device is switched off.
 - Pedal in pedal position "-2"
 - Trimming device is switched on.
- Press "P" button. F-173
- Press "P" button.

8.3 Installation or replacement of the control box

Installation of the control box has been taken care of by Strobel Co. already at delivery. An installation of the control box therefore needs to be done only after a replacement.



CAUTION!

The replacement of the control box may be done only by an electrician.

When installing the control box ensure, check, and set the following:



CAUTION!

Switch the machine off electrically by the main switch S0 and pull the power plug.

- Switch the machine electrically with the S0 main switch and pull the power plug.
- Disconnect all plug-in outlets on the back of the control box.
- Unscrew the bonding function of the control box back (if available).
- Unscrew the control box, replace and screw back on.



CAUTION!

Before replacing the control box check that the electrical connection specifications on the control box's type plate, especially the network voltage and frequency are appropriate for your electric network.

- Check the proper assembly of the motor and any accessories used.
- Screw the bonding function of the control box back (if any) back.
- Connect all plug-in outlets on the back of the control box.
- Plug in the power plug, switch the machine on with the S0 main switch, and enter code number "311" or "3112".
- Set machine mode with parameter F-290.
- Set machine direction of rotation with parameter F-161.
- Set motor-to-machine transmission ratio with parameter F-272.
- Set type of position sensors with parameter F-270.
- Set needle positions with parameters F-170 and F-171.
- Set sewing machine compatible speed with parameters F-110...121.
- Set the input functions with the parameters F-240...249.
- Set the remaining parameters according to the Strobel parameter list.
- Set the switchable functions.

Be sure to observe the chapters of this manual respective to the individual points.

8.4 Replacement of the motor

When replacing the motor ensure, check, and set the following:



CAUTION!

Switch the machine's electric power off and pull the power plug.

- Switch the machine's electric power off and pull the power plug.
- Disconnect the two plug-in outlets of the motor on the back of the control box.
- Replace the motor.



CAUTION!

Before replacing the motor check that the electrical connection specifications on the motor's type plate, especially the network voltage and output are appropriate for the control's data.

- Check the proper assembly of the motor and the belt protection.
- Connect the two plug-in outlets of the motor on the back of the control box.
- Plug in power plug, switch machine on, and enter code number "190" or "1907".
- Set needle positions with parameters F-170 and F-171.

Be sure to observe the chapters of this manual respective to the individual points.

8.5 Replacement of the external pulse generator (position transmitter)

When replacing the external pulse generator ensure, check, and set the following:



CAUTION!

Switch the machine's electric power off and pull the power plug.

- Switch the machine's electric power off and pull the power plug.
- Disconnect the pulse generator's plug-in outlet on the back of the control box.
- Replace the pulse generator.



CAUTION!

Before replacing the pulse generator check that the new pulse generator's type plate matches the old pulse generator's type plate.

- Check the proper assembly of the pulse generator.
- Connect the pulse generator's plug-in outlet on the back of the control box.
- Plug in power plug, switch machine on, and enter code number "190" or "1907".
- Set needle positions with parameters F-170 and F-171.

Be sure to observe the chapters of this manual respective to the individual points.

8.6 Fault messages

8.6.1 General information

On the control	On the V810 operating control	Description
A1	InF A1	Pedal is not in pedal position "0" when the machine is switched on
A2	-StoP- blinks	Run inhibition active
A3	InF A6	Reference position not set

8.6.2 Programming functions and values (parameters)

On the control	On the V810 operating control	Description
Returns to "0000"	Returns to "0000"	Wrong code number input
Returns to last parameter number	Returns to last parameter number	Wrong parameter number input

8.6.3 Serious status

On the control	On the V810 operating control	Description
E1	InF E1	The external pulse encoder (if available) e.g. IPG... is defective or not connected.
E2	InF E2	Network voltage too low or period between power-off and -on too brief.
E3	InF E3	Machine blocked or does not reach desired speed.
E4	InF E4	Control fault due to insufficient earth or loose contact.

8.6.4 Hardware fault

On the control	On the V810 operating control	Description
H1	InF H1	Commutation transmitter in-line or converter faulty
H2	InF H2	Defective processor

Mains connection plan cl. gen. (DC1500/DC1550 with/without sewing machine lamp gen.)

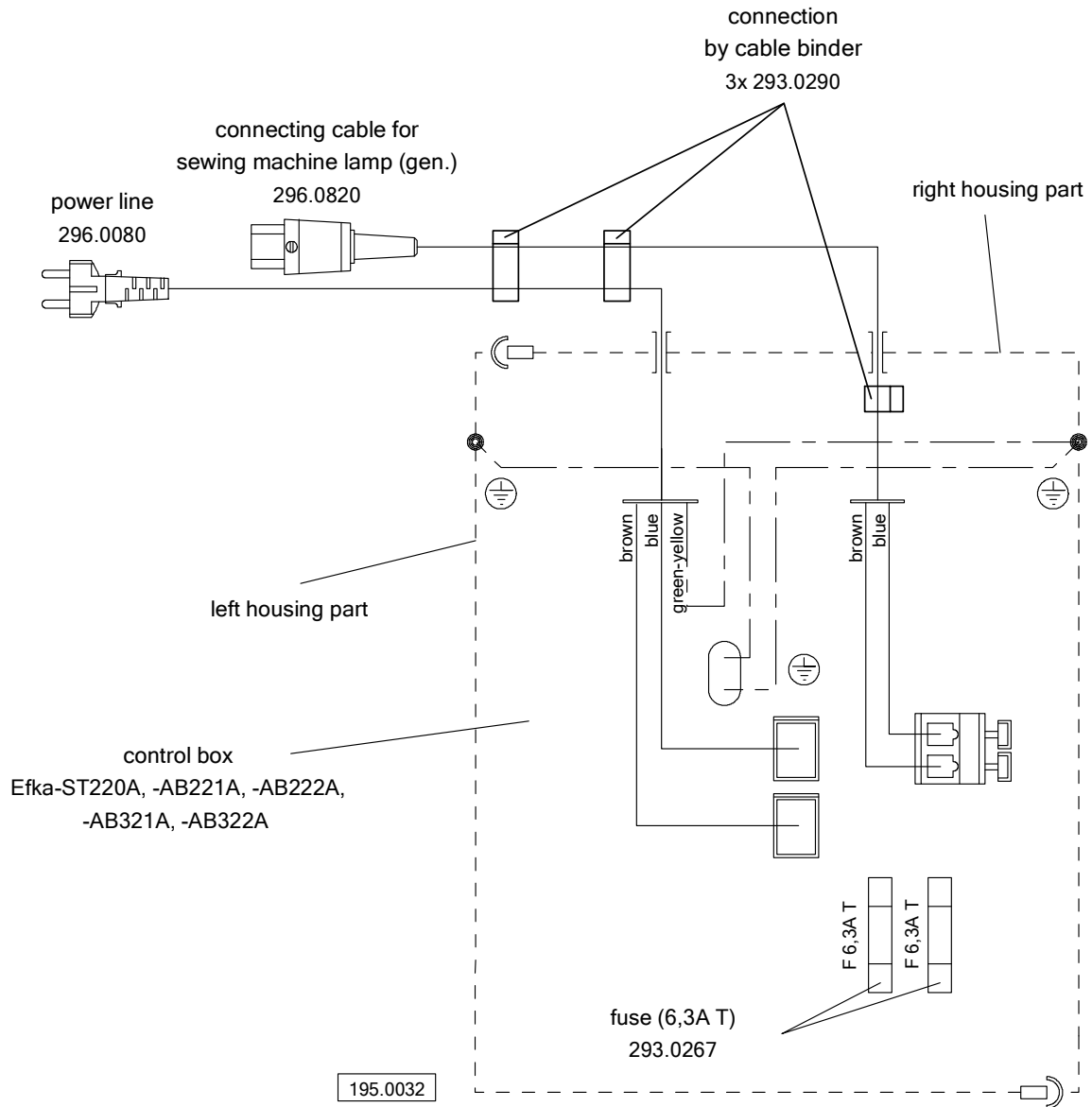

Mains facility connection plan cl. general (DC1500/DC1550 with/without sewing machine lamp gen.)

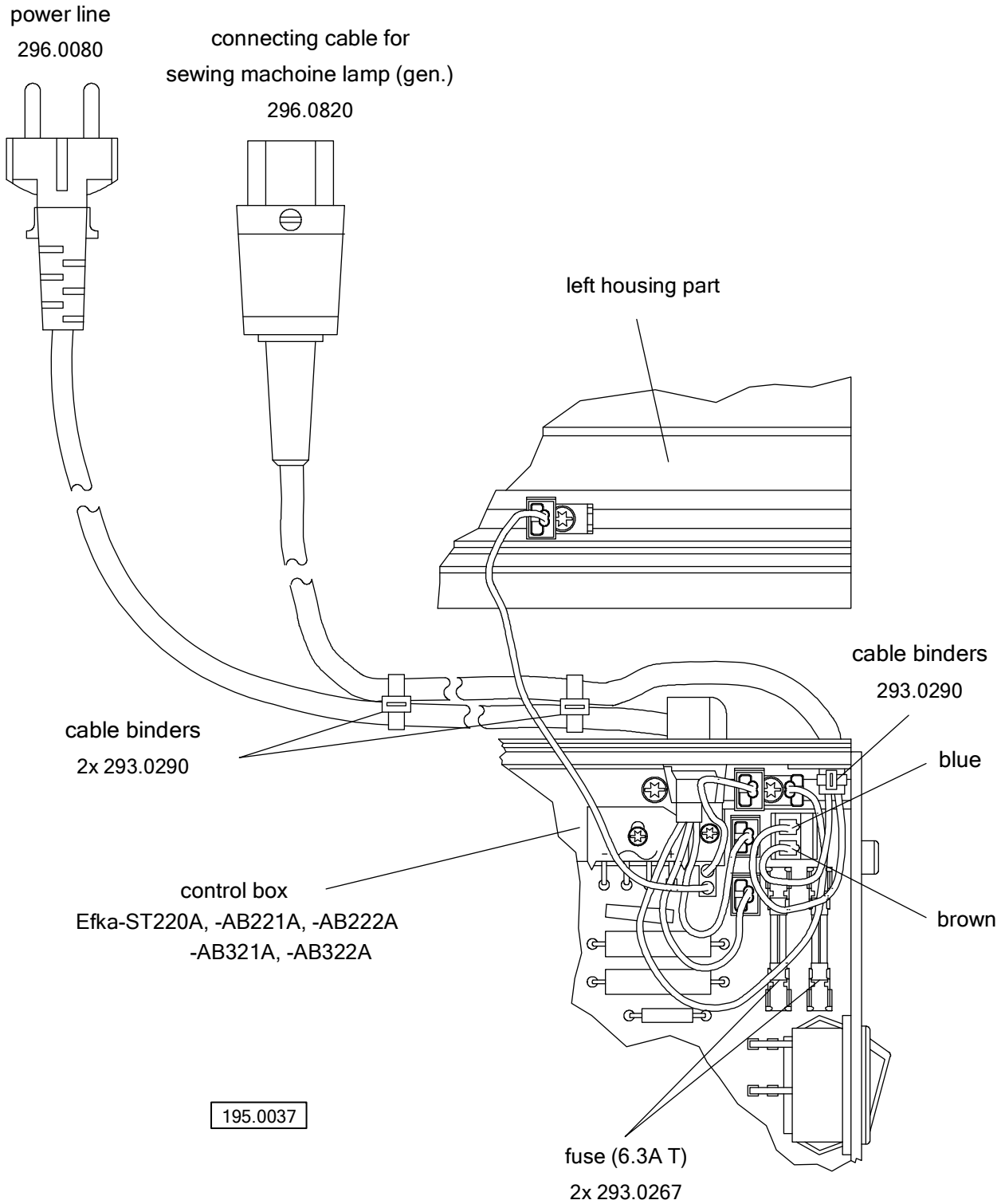

Mains connection plan cl. 103-258M(B) (DC1500-ST220A with/without sewing machine lamp gen.)

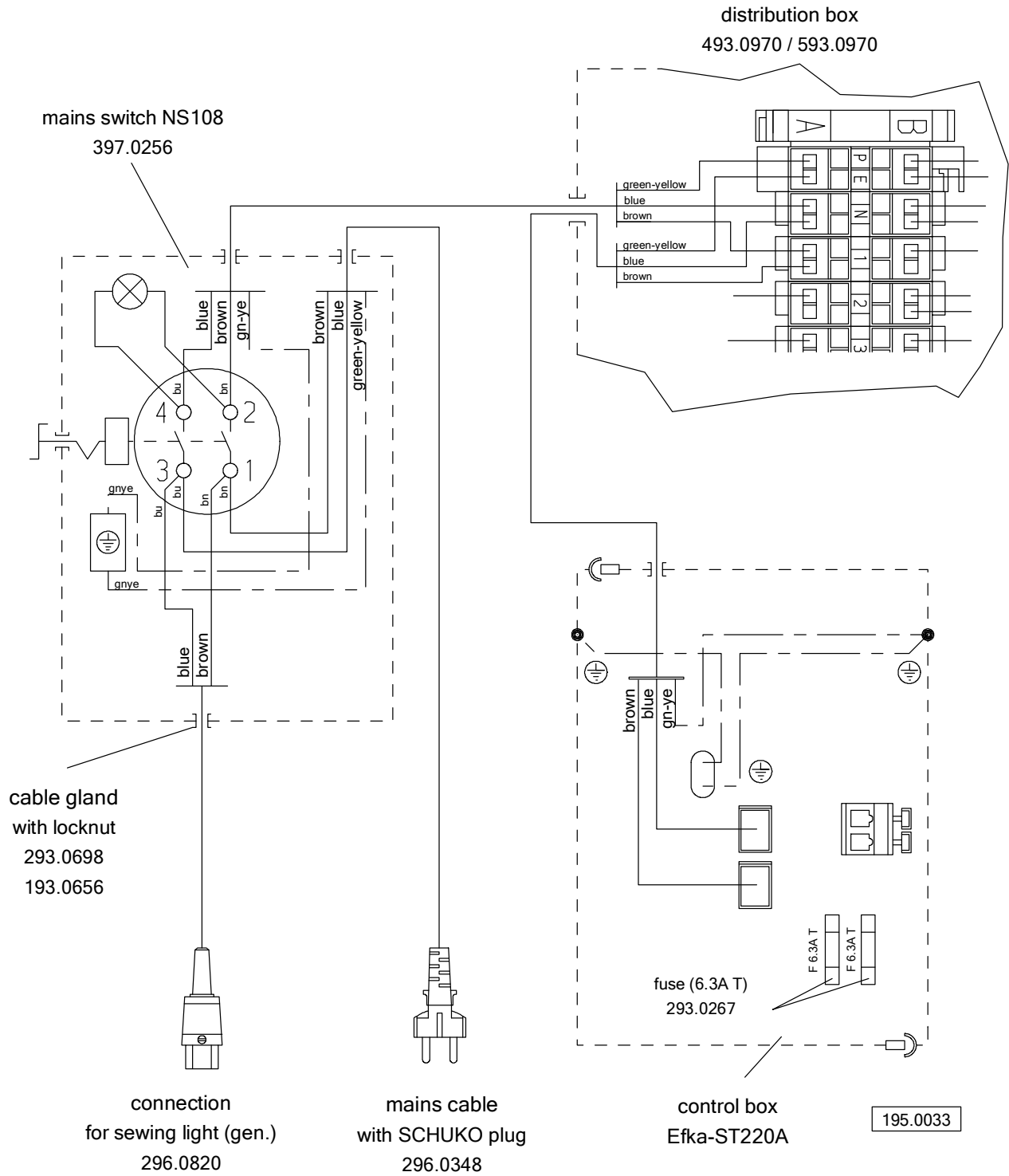

Electrical connection plan cl. 45, 58, 103, 120, 170 (DC1500-ST220A)

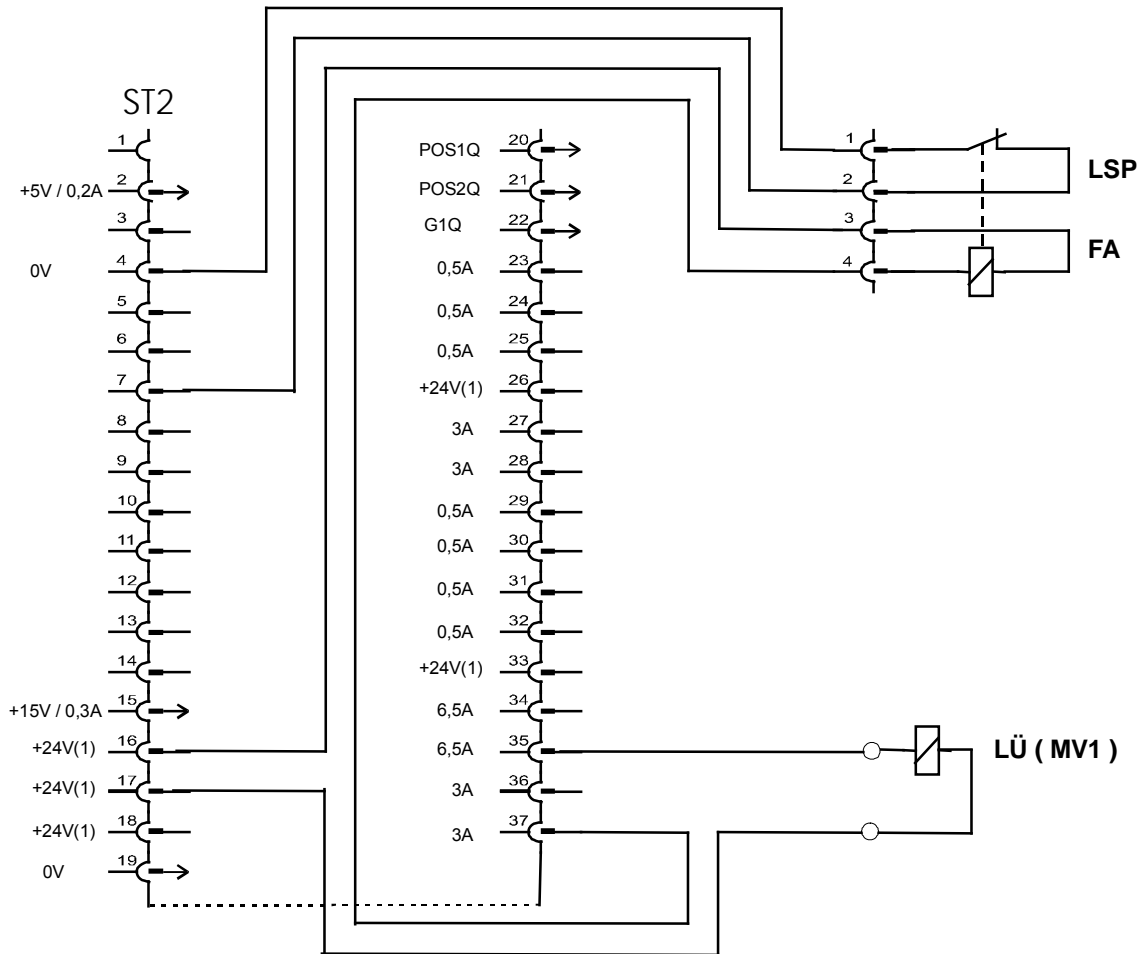

Control box Efka drive

(1) Nominal voltage 24V, idle voltage max. 30V

Designation Strobel operating manual	Designation Efka operating manual	PIN 37 pin Sub-D	Colour code connection cable
Thread trimmer (FA)	Output 1 (M1)	37 16	yellow brown
Run inhibition (LSP)	Input 1 (IN1)	7 4	grey blue
Lifting (LÜ)	Press foot lifting (FL)	35 17	white brown

Electrical connection plan cl. 45, 103, 170 with backtick (DC1500-ST220A)

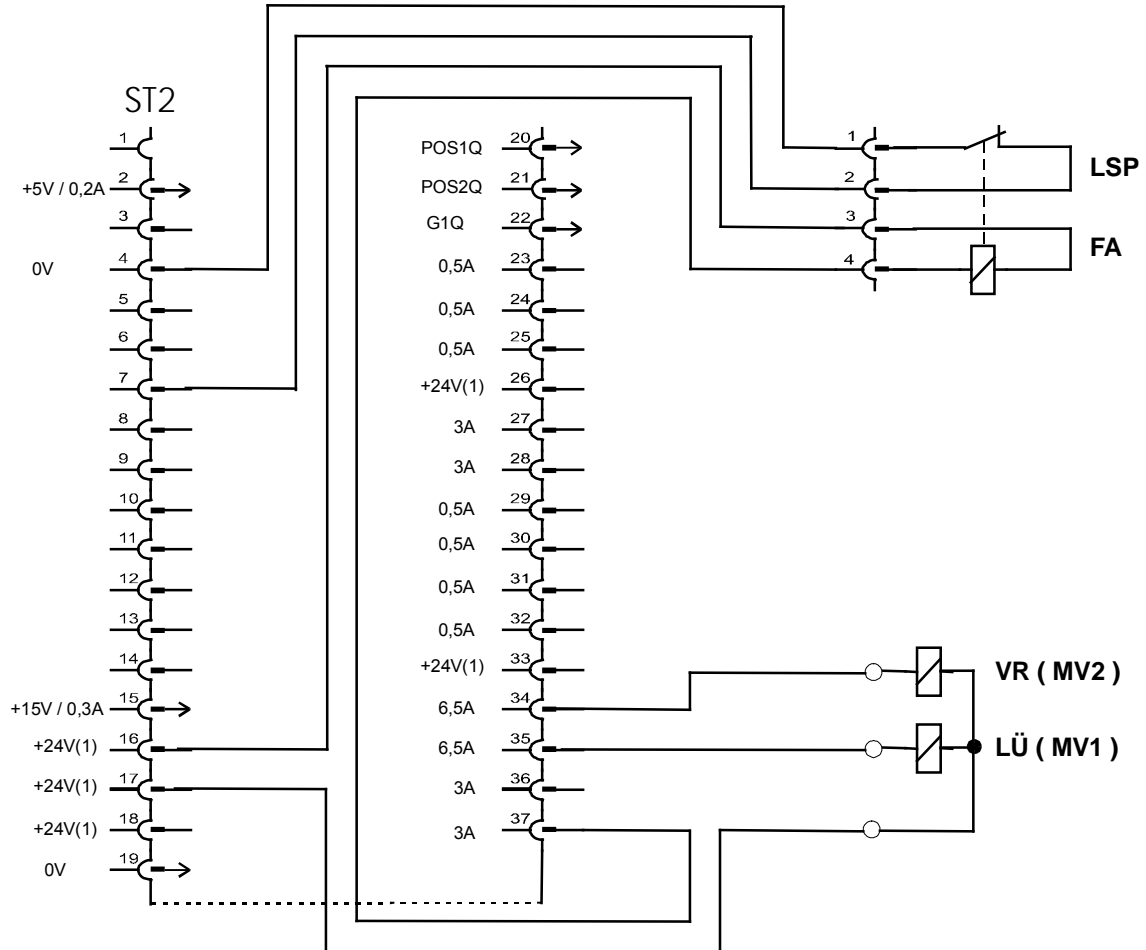

Control box Efka drive

(1) Nominal voltage 24V, idle voltage max. 30V

Designation Strobel operating manual	Designation Efka operating manual	PIN 37 pin Sub-D	Colour code connection cable
Thread trimmer (FA)	Output 1 (M1)	37 16	yellow brown
Run inhibition (LSP)	Input 1 (IN1)	7 4	grey blue
Lifting (LÜ)	Press foot lifting (FL)	35 17	white brown
Locking system (VR)	Locking system (VR)	34 17	green brown

Electrical connection plan cl. 103-258M (Efka-DC1500-ST220A)

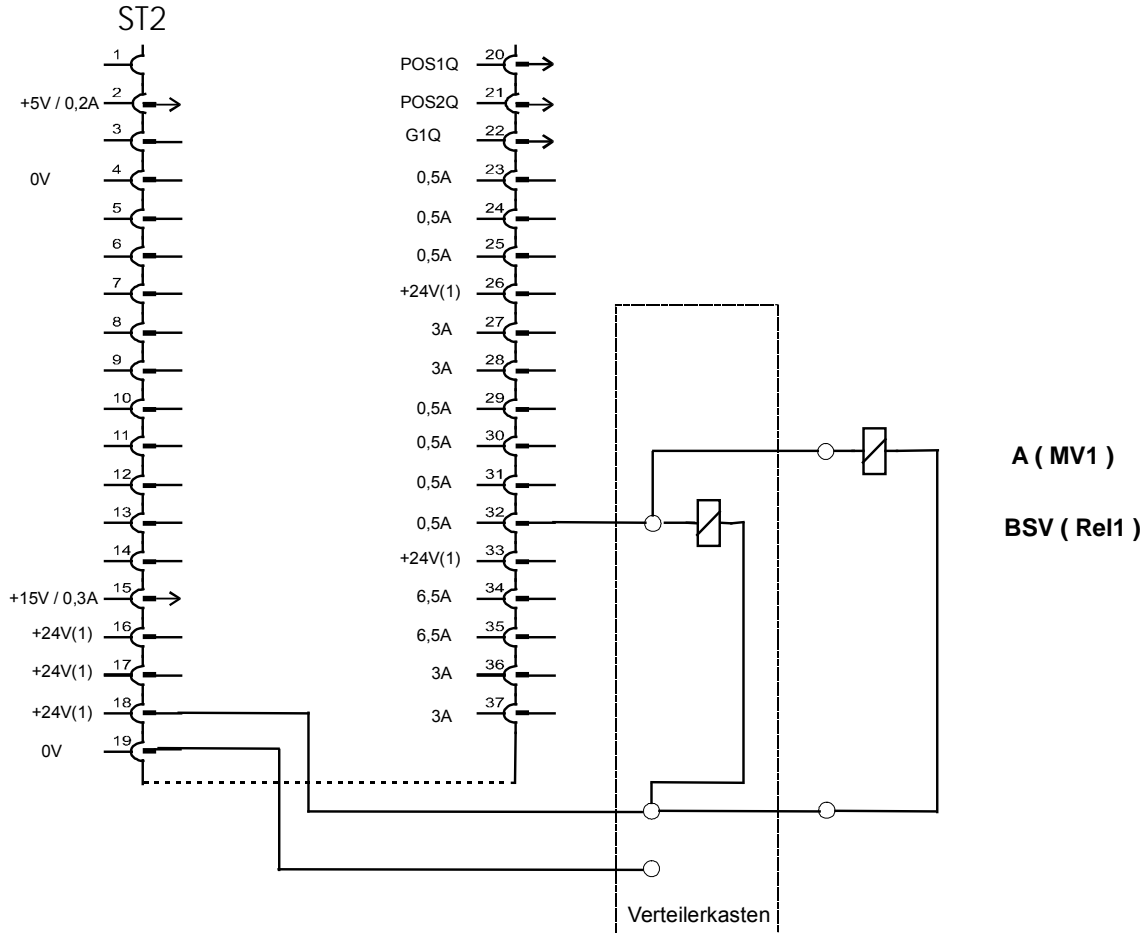

Control box Efka drive

(1) Nominal voltage 24V, idle voltage max. 30V

Designation Strobel operating manual	Designation Efka operating manual	PIN 37 pin Sub-D	Colour code connection cable
Trimming device draining (A) (BSV)	Machine run (M5)	32	green
		18 19	brown white

Electrical connection plan cl. 142 (DC1500-ST220A)

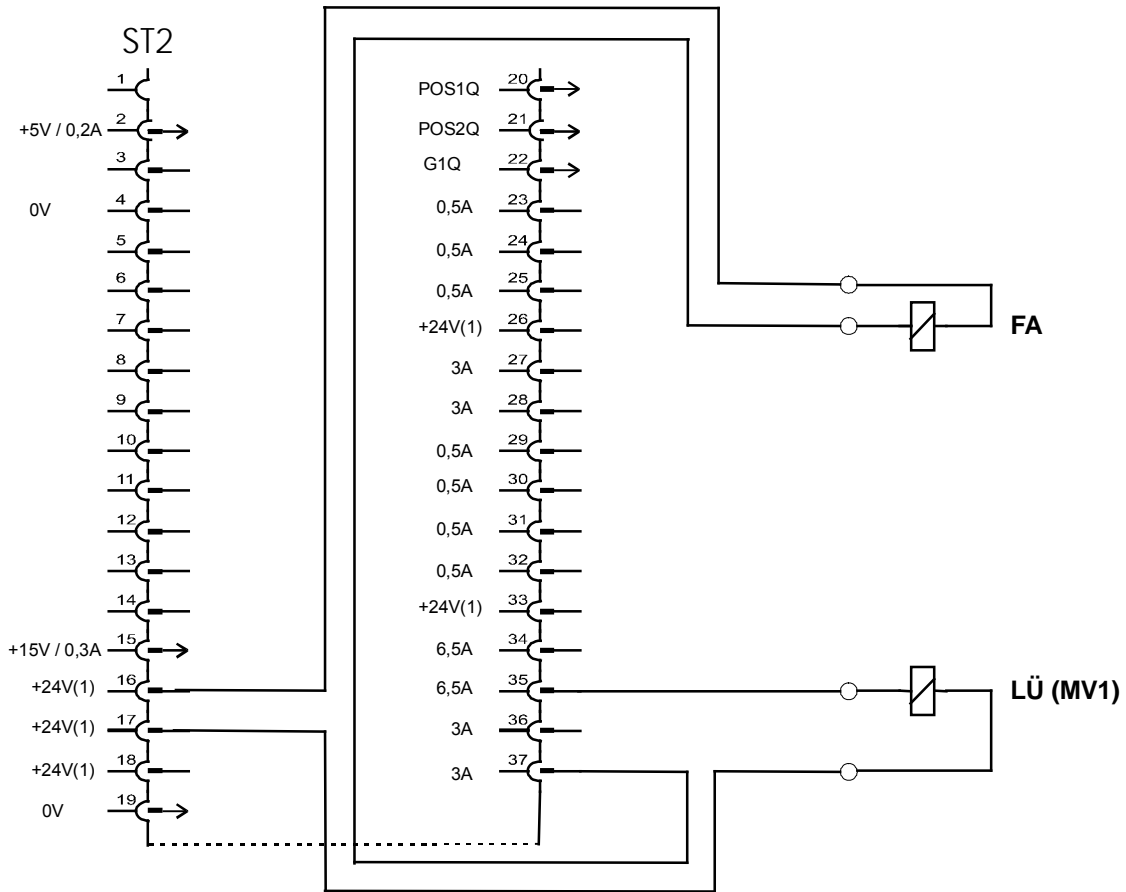

Control box Efka drive

(1) Nominal voltage 24V, idle voltage max. 30V

Designation Strobel operating manual	Designation Efka operating manual	PIN 37 pin Sub-D	Colour code connection cable
Thread trimmer (FA)	Output 1 (M1)	37 16	yellow brown
Lifting (LÜ)	Press foot lifting (FL)	35 17	white brown

Electrical connection plan cl. 200, 300 (DC1500-ST220A)

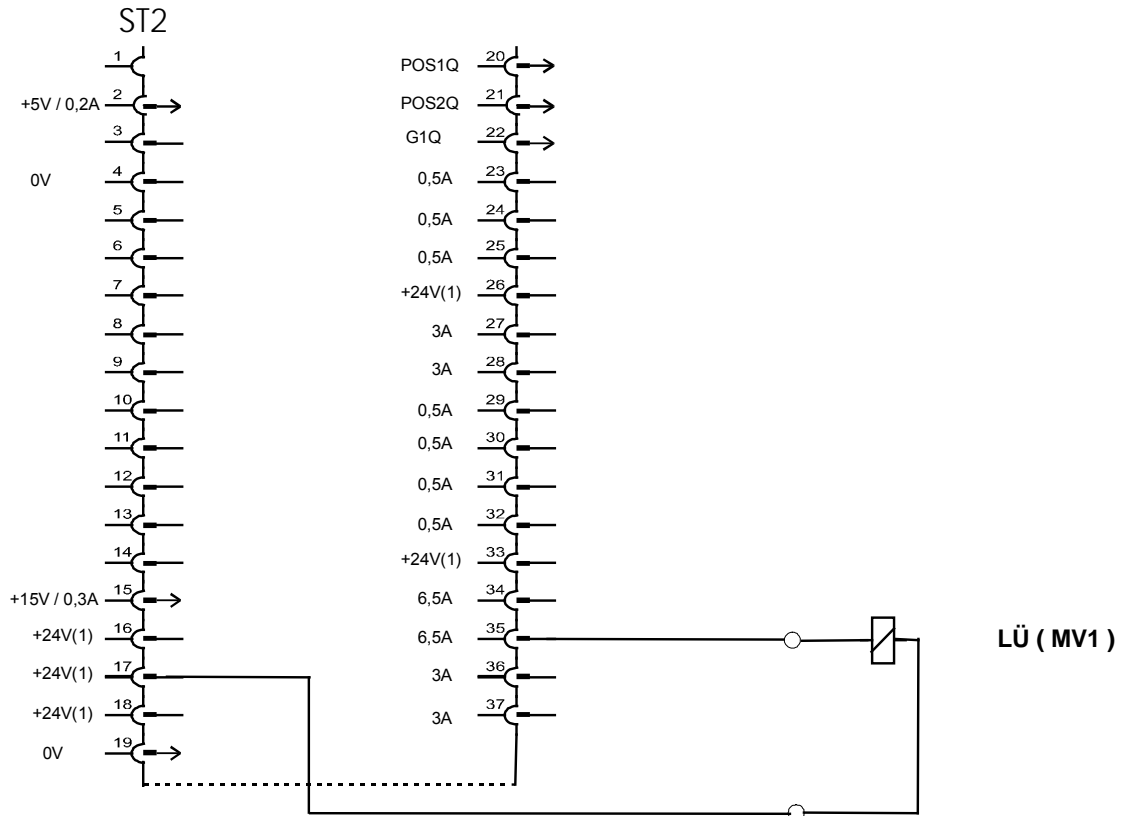

Control box Efka drive

(1) Nominal voltage 24V, idle voltage max. 30V

Designation Strobel operating manual	Designation Efka operating manual	PIN 37 pin Sub-D	Colour code connection cable
Lifting (LÜ)	Press foot lifting (FL)	35 17	White brown

Electrical diagram cl. 218D-TP as of version 3 and cl. 325-40D-TP as of version 9

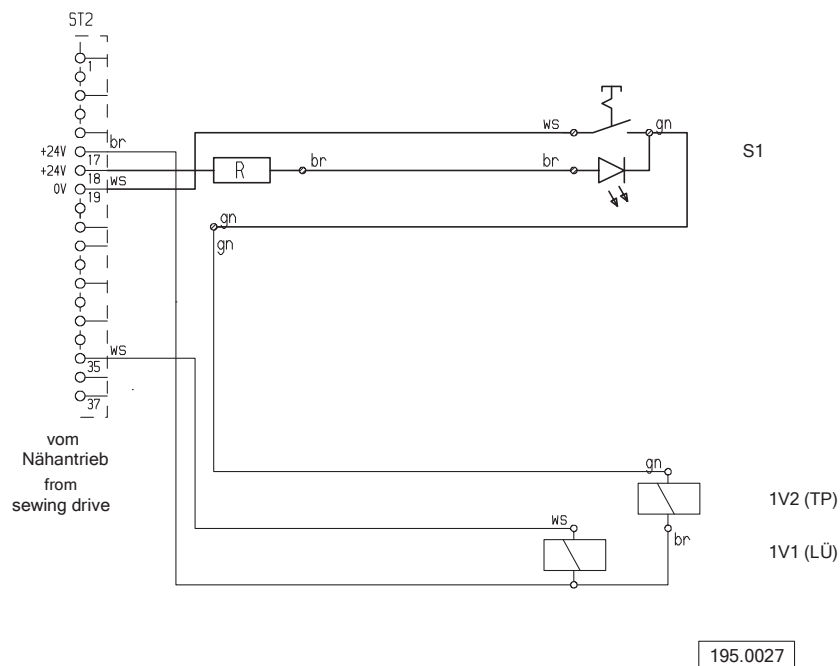

1V1 Magnetventil "Lüftung" (LÜ)
1V2 Magnetventil "Taucherabsenkung" (TP)
R Widerstand
S1 Schalter mit LED
ST2 Stecker Steuerkasten (Nähانtrieb)

1V1 solenoid valve "lifting" (LÜ)
1V2 solenoid valve "plunger lowering" (TP)
R resistor
S1 switch with LED
ST2 plug control box (sewing drive)

Electrical connection plan cl. 560-11 at model 3 (DC1500-ST220A)

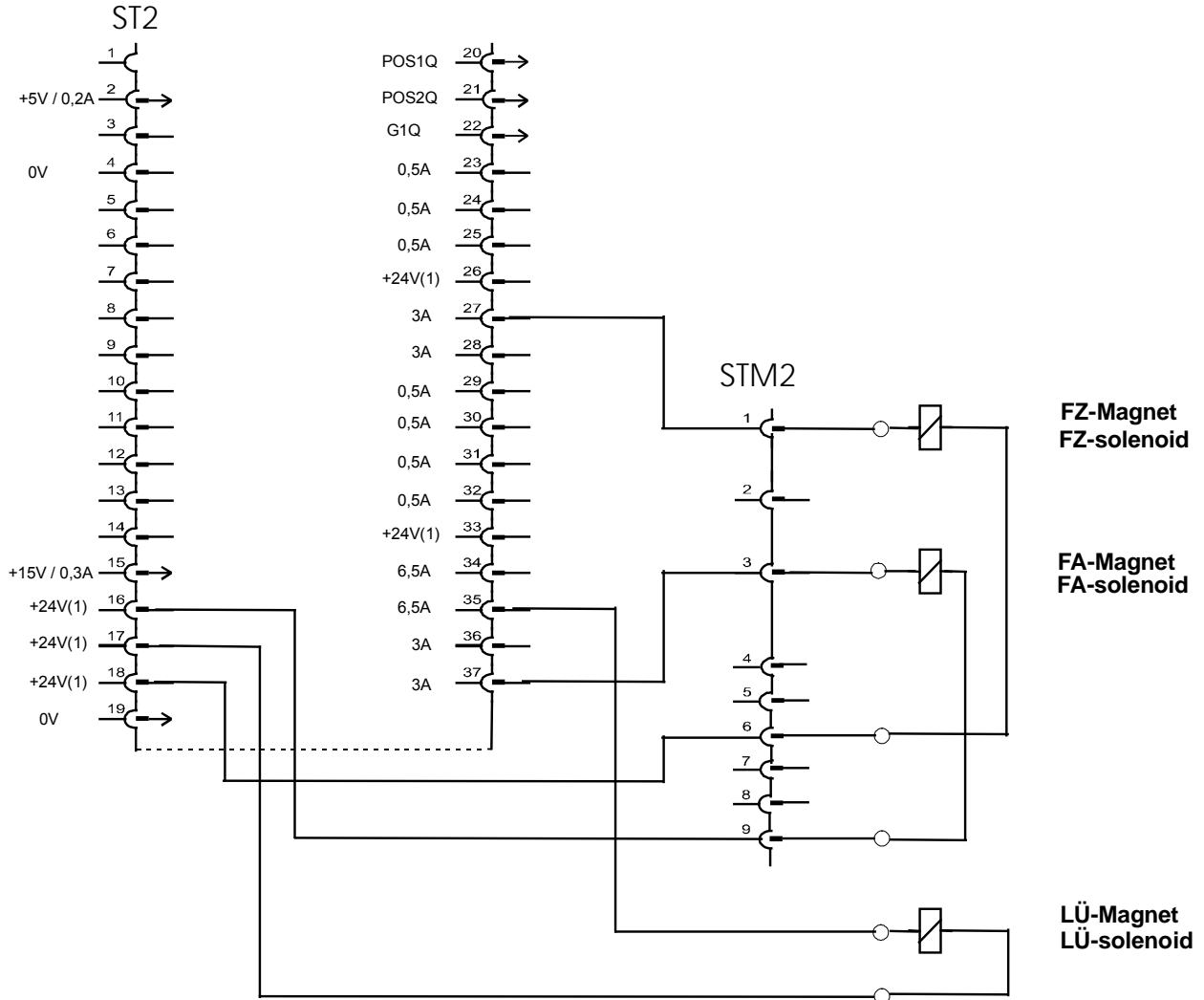

Control box Efka drive

(1) Nominal voltage 24V, idle voltage max. 30V

Designation Strobel operating manual	Designation Efka operating manual	PIN 37 pin Sub-D	Colour code connection cable
Lifting (LÜ)	Lifting (LÜ)	35 17	white brown
Thread trimmer (FA)	Output 1 (M1)	37 16	yellow brown
Thread puller (FZ)	Output 3 (M3)	27 18	green grey

Electrical connection plan
Digital stitch depth display (DSA) cl. 103
(DC1500-ST220A)

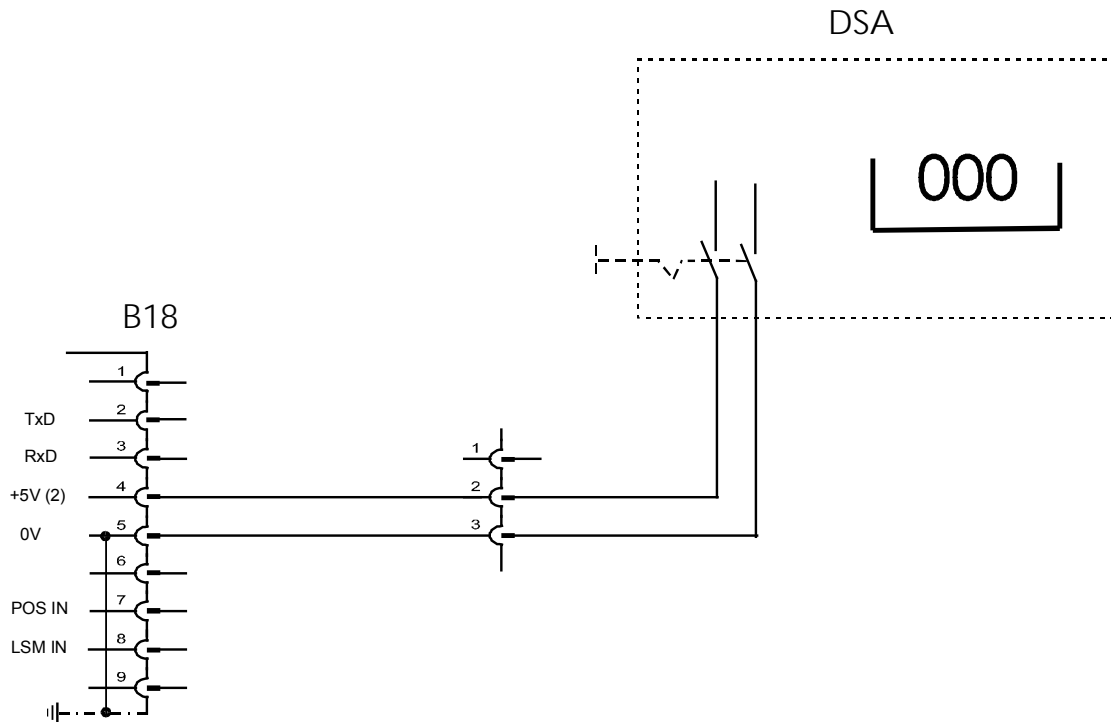

Control box Efka drive
(2) Nominal voltage 5V, 100mA

Designation Strobel operating manual	PIN 9 pin Sub-D	Colour code connection cable
Digital stitch depth display (DSA)	4 5	brown white

Machine class	Switchable Functions (DC1500-ST220A)																																																																																																																																																																																																																																																																																																																																																																																																																																																																																																																																																																																																																																																																																																																																																																																																																																																																																																																																																																																																																																																																																																																																																																																																																																																																																																																																																																																
	"Control"					"V810 operating control"																																																																																																																																																																																																																																																																																																																																																																																																																																																																																																																																																																																																																																																																																																																																																																																																																																																																																																																																																																																																																																																																																																																																																																																																																																																																																																																																																																											
	(see 5.1.2.2 Button assignment on the control)					(see 5.2.2.3 Button assignment on the V810 operating control)																																																																																																																																																																																																																																																																																																																																																																																																																																																																																																																																																																																																																																																																																																																																																																																																																																																																																																																																																																																																																																																																																																																																																																																																																																																																																																																																																																											
F-290	F-291	Plug-in strip number for V810 operating control	00	01	02	03	04	05	06	07	08	09	10	11	12	13	14	15	16	17	18	19	20	21	22	23	24	25	26	27	28	29	30	31	32	33	34	35	36	37	38	39	40	41	42	43	44	45	46	47	48	49	50	51	52	53	54	55	56	57	58	59	60	61	62	63	64	65	66	67	68	69	70	71	72	73	74	75	76	77	78	79	80	81	82	83	84	85	86	87	88	89	90	91	92	93	94	95	96	97	98	99	100	101	102	103	104	105	106	107	108	109	110	111	112	113	114	115	116	117	118	119	120	121	122	123	124	125	126	127	128	129	130	131	132	133	134	135	136	137	138	139	140	141	142	143	144	145	146	147	148	149	150	151	152	153	154	155	156	157	158	159	160	161	162	163	164	165	166	167	168	169	170	171	172	173	174	175	176	177	178	179	180	181	182	183	184	185	186	187	188	189	190	191	192	193	194	195	196	197	198	199	200	201	202	203	204	205	206	207	208	209	210	211	212	213	214	215	216	217	218	219	220	221	222	223	224	225	226	227	228	229	230	231	232	233	234	235	236	237	238	239	240	241	242	243	244	245	246	247	248	249	250	251	252	253	254	255	256	257	258	259	260	261	262	263	264	265	266	267	268	269	270	271	272	273	274	275	276	277	278	279	280	281	282	283	284	285	286	287	288	289	290	291	292	293	294	295	296	297	298	299	300	301	302	303	304	305	306	307	308	309	310	311	312	313	314	315	316	317	318	319	320	321	322	323	324	325	326	327	328	329	330	331	332	333	334	335	336	337	338	339	340	341	342	343	344	345	346	347	348	349	350	351	352	353	354	355	356	357	358	359	360	361	362	363	364	365	366	367	368	369	370	371	372	373	374	375	376	377	378	379	380	381	382	383	384	385	386	387	388	389	390	391	392	393	394	395	396	397	398	399	400	401	402	403	404	405	406	407	408	409	410	411	412	413	414	415	416	417	418	419	420	421	422	423	424	425	426	427	428	429	430	431	432	433	434	435	436	437	438	439	440	441	442	443	444	445	446	447	448	449	450	451	452	453	454	455	456	457	458	459	460	461	462	463	464	465	466	467	468	469	470	471	472	473	474	475	476	477	478	479	480	481	482	483	484	485	486	487	488	489	490	491	492	493	494	495	496	497	498	499	500	501	502	503	504	505	506	507	508	509	510	511	512	513	514	515	516	517	518	519	520	521	522	523	524	525	526	527	528	529	530	531	532	533	534	535	536	537	538	539	540	541	542	543	544	545	546	547	548	549	550	551	552	553	554	555	556	557	558	559	560	561	562	563	564	565	566	567	568	569	570	571	572	573	574	575	576	577	578	579	580	581	582	583	584	585	586	587	588	589	590	591	592	593	594	595	596	597	598	599	600	601	602	603	604	605	606	607	608	609	610	611	612	613	614	615	616	617	618	619	620	621	622	623	624	625	626	627	628	629	630	631	632	633	634	635	636	637	638	639	640	641	642	643	644	645	646	647	648	649	650	651	652	653	654	655	656	657	658	659	660	661	662	663	664	665	666	667	668	669	670	671	672	673	674	675	676	677	678	679	680	681	682	683	684	685	686	687	688	689	690	691	692	693	694	695	696	697	698	699	700	701	702	703	704	705	706	707	708	709	710	711	712	713	714	715	716	717	718	719	720	721	722	723	724	725	726	727	728	729	730	731	732	733	734	735	736	737	738	739	740	741	742	743	744	745	746	747	748	749	750	751	752	753	754	755	756	757	758	759	760	761	762	763	764	765	766	767	768	769	770	771	772	773	774	775	776	777	778	779	780	781	782	783	784	785	786	787	788	789	790	791	792	793	794	795	796	797	798	799	800	801	802	803	804	805	806	807	808	809	810	811	812	813	814	815	816	817	818	819	820	821	822	823	824	825	826	827	828	829	830	831	832	833	834	835	836	837	838	839	840	841	842	843	844	845	846	847	848	849	850	851	852	853	854	855	856	857	858	859	860	861	862	863	864	865	866	867	868	869	870	871	872	873	874	875	876	877	878	879	880	881	882	883	884	885	886	887	888	889	890	891	892	893	894	895	896	897	898	899	900	901	902	903	904	905	906	907	908	909	910	911	912	913	914	915	916	917	918	919	920	921	922	923	924	925	926	927	928	929	930	931	932	933	934	935	936	937	938	939	940	941	942	943	944	945	946	947	948	949	950	951	952	953	954	955	956	957	958	959	960	961	962	963	964	965	966	967	968	969	970	971	972	973	974	975	976	977	978	979	980	981	982	983	984	985	986	987	988	989	990	991	992	993	994	995	996	997	998	999	1000	1001	1002	1003	1004	1005	1006	1007	1008	1009	1010	1011	1012	1013	1014	1015	1016	1017	1018	1019	1020	1021	1022	1023	1024	1025	1026	1027	1028	1029	1030	1031	1032	1033	1034	1035	1036	1037	1038	1039	1040	1041	1042	1043	1044	1045	1046	1047	1048	1049	1050	1051	1052	1053	1054	1055	1056	1057	1058	1059	1060	1061	1062	1063	1064	1065	1066	1067	1068	1069	1070	1071	1072	1073	1074	1075	1076	1077	1078	1079	1080	1081	1082	1083	1084	1085	1086	1087	1088	1089	1090	1091	1092	1093	1094	1095	1096	1097	1098	1099	1100	1101	1102	1103	1104	1105	1106	1107	1108	1109	1110	1111	1112	1113	1114	1115	1116	1117	1118	1119	1120	1121	1122	1123	1124	1125	1126	1127	1128	1129	1130	1131	1132	1133	1134	1135	1136	1137	1138	1139	1140	1141	1142	1143	1144	1145	1146	1147	1148	1149	1150	1151	1152	1153	1154	1155	1156	1157	1158	1159	1160	1161	1162	1163	1164	1165	1166	1167	1168	1169	1170	1171	1172	1173	1174	1175	1176	1177	1178	1179	1180	1181	1182	1183	1184	1185	1186	1187	1188	1189	1190	1191	1192	1193	1194	1195	1196	1197	1198	1199	1200	1201	1202	1203	1204	1205	1206	1207	1208	1209	1210	1211	1212	1213	1214	1215	1216	1217	1218	1219	1220	1221	1222	1223	1224	1225	1226	1227	1228	1229	1230	1231	1232	1233	1234	1235	1236	1237	1238	1239	1240	1241	1242	1243	1244	1245	1246	1247	1248	1249	1250	1251	1252	1253	1254	1255	1256	1257	1258	1259	1260	1261	1262	1263	1264	1265	1266	1267	1268	1269	1270	1271	1272	1273	1274	1275	1276	1277	1278	1279	1280	1281	1282	1283	1284	1285	1286	1287	1288	1289	1290	1291	1292	1293	1294	1295	1296	1297	1298	1299	1300	1301	1302	1303	1304	1305	1306	1307	1308	1309	1310	1311	1312	1313	1314	1315	1316	1317	1318	1319	1320	1321	1322	1323	1324	1325	1

Strobel - Parameter list















Machine class		Parameter (DC1500-ST220A)	
F-122	Limited speed n9	0200 9900	min-1
F-123	Limited speed n11	0200 9900	min-1
F-127	Acoustical signal (only V810) On/Off	0 1	
F-128	Starting delay light barrier (see F-129)	0000 2000	ms
F-129	Starting machine with light barrier (see F-132)	0 3	
F-130	Light barrier filter OFF / ON	0 1	
F-131	Light barrier sensing DARK / LIGHT	0 1	
F-132	Starting light barrier light and/or dark	0 1	
F-133	Thread trimmer after light barrier OFF / ON	0 1	
F-134	Softstart OFF / ON	0 1	
F-135	Festoon stitch backtack OFF / ON	0 1	
F-139	Display machine speedometer (only V810) OFF / ON	0 1	
F-141	Speed status for a stitching with stitch count	0 4	
F-142	Speed for the free stitch and the stitch with light barrier	0 3	
F-150	Stitch formation correction double starting backtack	000 500	ms
F-152	Stitch formation correction double end backtack	000 500	ms
F-153	Holding force during machine standstill	00 50	
F-155	Control signal, trimming device OFF / ON	0 1	
F-156	Switch-off delay, control signal trimming device	0000 2550	ms
F-180	Number of turn-back steps	000 359	degree
F-181	Switch delay for turn back	000 990	ms
F-182	Turn back OFF / ON	0 1	
F-184	Number of stitches for sew-up stitch	000 254	
F-192	Speed status of the light barrier compensation stitches	0 1	
	Setting range		
	Einheit		
	Display value control x		
	45-123; -223	0200	
	45-123F; -223F	0200	
	45-123RF; -223RF	0200	
	58-4	0200	
	58-4F	0200	
	103--180; -191	0200	
	103-180F; -191F	0200	
	103-180RF	0200	
	103-191RF	0200	
	103-161; -254; -256	0200	
	103-161F; -254F; -256F	0200	
	103-161RF	0200	
	103-258M; -258MB	0200	
	123-10D 124-14D	0200	
	123-10FD 124-14FD	0200	

Machine class	Parameter (DC1500-ST220A)																								
	F-290	F-000	F-001	F-002	F-003	F-004	F-005	F-006	F-007	F-009	F-013	F-014	F-015	F-019	F-023	F-100	F-110	F-111	F-112	F-113	F-114	F-115	F-118	F-119	F-121
Setting range	00 07	000 254	000 254	000 254	000 254	000 254	000 254	01 15	000 254	0 1	0 1	0 1	0 1	0 4	0 1	000 254	070 390	n2_ 9900	0200 9900	0200 9900	0070 1500	0400 9900	0	0200	
Einheit																	min-1	min-1	min-1	min-1	min-1	min-1	min-1	min-1	
Display value control x																	10	10	10	10	10	10	10	10	
141-23EV	01	-	-	-	-	007	001	01	008	0	-	-	0	1	1	002	200	1800	-	-	1000	0500	1400	2	0400
141-30	01	-	-	-	-	007	001	01	008	0	-	-	0	1	1	002	200	2300	-	-	1000	0500	1400	2	0400
141-40; -50	01	-	-	-	-	007	001	01	008	0	-	-	0	1	1	002	200	3600	-	-	1000	0500	1400	2	0400
142-30	01	-	-	-	-	007	001	01	008	0	-	-	0	1	1	002	200	2300	-	-	1000	0500	1400	2	0400
142-30F	01	-	-	-	-	007	001	01	008	0	-	-	0	3	1	002	200	2300	-	-	1000	0500	1400	2	0400
170-22D	01	-	-	-	-	007	001	01	008	0	-	-	0	1	1	002	200	2200	-	-	1000	0500	1400	2	0400
170-22FD	01	-	-	-	-	007	001	01	008	0	-	-	0	3	1	002	200	2200	-	-	1000	0500	1400	2	0400
170-22RFD	02	000	000	003	000	007	001	01	008	0	1	-	0	3	1	002	200	2200	0600	0600	1000	0500	1400	2	0400
218D-S; 218D-TP 327D	01	-	-	-	-	007	001	01	008	0	-	-	0	1	1	002	200	1300	-	-	1000	0500	1400	2	0400
310D 3100D; 3200D	01	-	-	-	-	007	001	01	008	0	-	-	0	1	1	002	100	0600	-	-	0500	0300	0700	2	0200
325-40D-TP	01	-	-	-	-	007	001	01	008	0	-	-	0	1	1	002	200	1300	-	-	1000	0500	1400	2	0400
560-11	07	-	-	-	-	007	001	01	008	0	1	1	1	-	1	002	300	1600	-	-	0800	0500	1600	2	0400

Machine class	Parameter (DC1500-ST220A)																										
	F-122	F-123	F-127	F-128	F-129	F-130	F-131	F-132	F-133	F-134	F-135	F-139	F-141	F-142	F-150	F-152	F-163	F-155	F-156	F-158	F-161	F-180	F-181	F-182	F-184	F-192	
Setting range	0200 9900	0200 9900	0 1	0000 2000	0 3	0 1	0 1	0 1	0 1	0 1	0 1	0 1	0 4	0 3	000 500	000 500	00 50	0 1	0000 2550	000 500	000 990	0 1	000 359	000 990	0 1	000 254	0 1
Einheit	min-1	min-1		ms											ms	ms		ms	ms	ms	ms	degree	ms				
Display value control x	10	10		10															10								
141-23EV	0200	2500	0	0500	2	0	1	1	0	0	-	0	0	0	-	-	10	0	0000	000	200	0	0	0	-	0	
141-30	0200	2500	0	0500	2	0	1	1	0	0	-	0	0	0	-	-	10	0	0000	000	200	0	0	0	-	0	
141-40; -50	0200	2500	0	0500	2	0	1	1	0	0	-	0	0	0	-	-	10	0	0000	000	200	0	0	0	-	0	
142-30	0200	2500	0	0500	2	0	1	1	0	0	-	0	0	0	-	-	10	0	0000	000	200	0	0	0	-	0	
142-30F	0200	2500	0	0500	2	0	1	1	0	0	-	0	0	0	-	-	10	0	0000	000	200	0	0	0	-	0	
170-22D	0200	2500	0	0500	2	0	1	1	0	0	-	0	0	0	-	-	10	0	0000	000	200	0	0	0	-	0	
170-22FD	0200	2500	0	0500	2	0	1	1	0	0	-	0	0	0	-	-	10	0	0000	000	200	0	0	0	-	0	
170-22RFD	0200	2500	0	0500	0	0	1	1	1	0	1	0	0	0	000	000	10	0	0000	000	200	0	0	0	-	0	
218D-S; 218D-TP 327D	0200	2500	0	0500	2	0	1	1	0	0	-	0	0	0	-	-	10	0	0000	000	200	0	0	0	-	0	
310D 3100D; 3200D	0200	1200	0	0500	2	0	1	1	0	0	-	0	0	0	-	-	10	0	0000	000	200	0	0	0	-	0	
325-40D-TP	0200	2500	0	0500	2	0	1	1	0	0	-	0	0	0	-	-	10	0	0000	000	200	0	0	0	-	0	
560-11	0200	2500	0	0500	0	0	1	1	1	0	-	0	3	0	-	-	10	-	-	000	010	0	0	0	-	0	

Machine class	Parameter (DC1500-ST220A)																									
	F-241	F-242 - F-249	F-254	F-255	F-266	F-269	F-270	F-271	F-272	F-280	F-281	F-284	F-285	F-288	F-291	F-293	F-294	F-300 - F-321	F-800	F-801	F-802	F-803	F-804	F-805	F-806	
Setting range	00 47	00 47	001 100	001 100	0 1	000 100	0 5	0 255	020 255	0000 2550	0000 2550	0000 2550	0000 2550	0000 2550	1 4	00 19	00 19		0000 2550	0000 2550	0000 2550	0000 2550	0000 2550	0000 2550	0000 2550	0 1
Einheit						degree				ms	ms	ms	ms	ms					ms	ms	ms	ms	ms	ms	ms	
Display value control	x									10	10	10	10	10					10	10	10	10	10	10	10	
141-23EV	00	00	100	-	0	015	4	180	074	0000	0180	0000	0000	0000	1	00	00	0	0000	0000	0000	0000	0000	0000	0000	0
141-30	00	00	100	-	0	015	4	180	074	0000	0180	0000	0000	0000	1	00	00	0	0000	0000	0000	0000	0000	0000	0000	0
141-40; -50	00	00	100	-	0	015	4	180	074	0000	0180	0000	0000	0000	1	00	00	0	0000	0000	0000	0000	0000	0000	0000	0
142-30	00	00	100	-	0	015	4	180	074	0000	0180	0000	0000	0000	1	00	00	0	0000	0000	0000	0000	0000	0000	0000	0
142-30F	00	00	100	-	0	015	4	180	074	0100	0180	0000	0000	0200	1	00	00	0	0000	0000	0000	0000	0000	0000	0000	0
170-22D	00	00	100	-	0	015	0	180	100	0000	0180	0000	0000	0200	1	00	00	0	0000	0000	0000	0000	0000	0000	0000	0
170-22FD	00	00	100	-	0	015	0	180	100	0100	0180	0000	0000	0200	1	00	00	0	0000	0000	0000	0000	0000	0000	0000	0
170-22RFD	00	00	100	100	0	015	0	180	100	0100	0180	0000	0000	0200	2	00	00	0	0000	0000	0000	0000	0000	0000	0000	0
218D-S; 218D-TP 327D	00	00	100	-	0	015	4	180	063	0000	0180	0000	0000	0000	1	00	00	0	0000	0000	0000	0000	0000	0000	0000	0
310D 3100D; 3200D	00	00	100	-	0	015	4	180	032	0000	0180	0000	0000	0000	1	00	00	0	0000	0000	0000	0000	0000	0000	0000	0
325-40D-TP	00	00	100	-	0	015	4	180	063	0000	0180	0000	0000	0000	1	00	00	0	0000	0000	0000	0000	0000	0000	0000	0
560-11	00	00	100	-	0	015	0	180	100	0070	0070	0000	0170	0100	4	00	00	0	0000	0000	0000	0000	0000	0000	0000	0

Stand: 18.04.12 - PT_ST220A5380C_1

										1 →
										2 →
										3 →
					S1					4 →
										→
										→
										→

Einschubstreifen_V810-ST220A-09.11

Einschubstreifen
V810-ST220A

Teile Nr.	Benennung
	Für DC1500-ST220A Nähhantrieb
296.0266	Kl. allg.: Anschlußleitung für Lüftung
296.0395	Kl. 103-258M(B): Anschlußleitung für Beschneid- vorrichtung, Magnetventile und Lüfter
296.0273	Kl. 142: Anschlußleitung für Fadenabschneider
296.0274	Kl. 142: Anschlußleitung für Lüftung und Fadenabschneider
296.0435	Kl. allg.: Anschlußleitung für Riegel
296.0438	Kl. allg.: Anschlußleitung für Fadenabschneider
296.0439	Kl. allg.: Anschlußleitung für Lüftung und Fadenabschneider

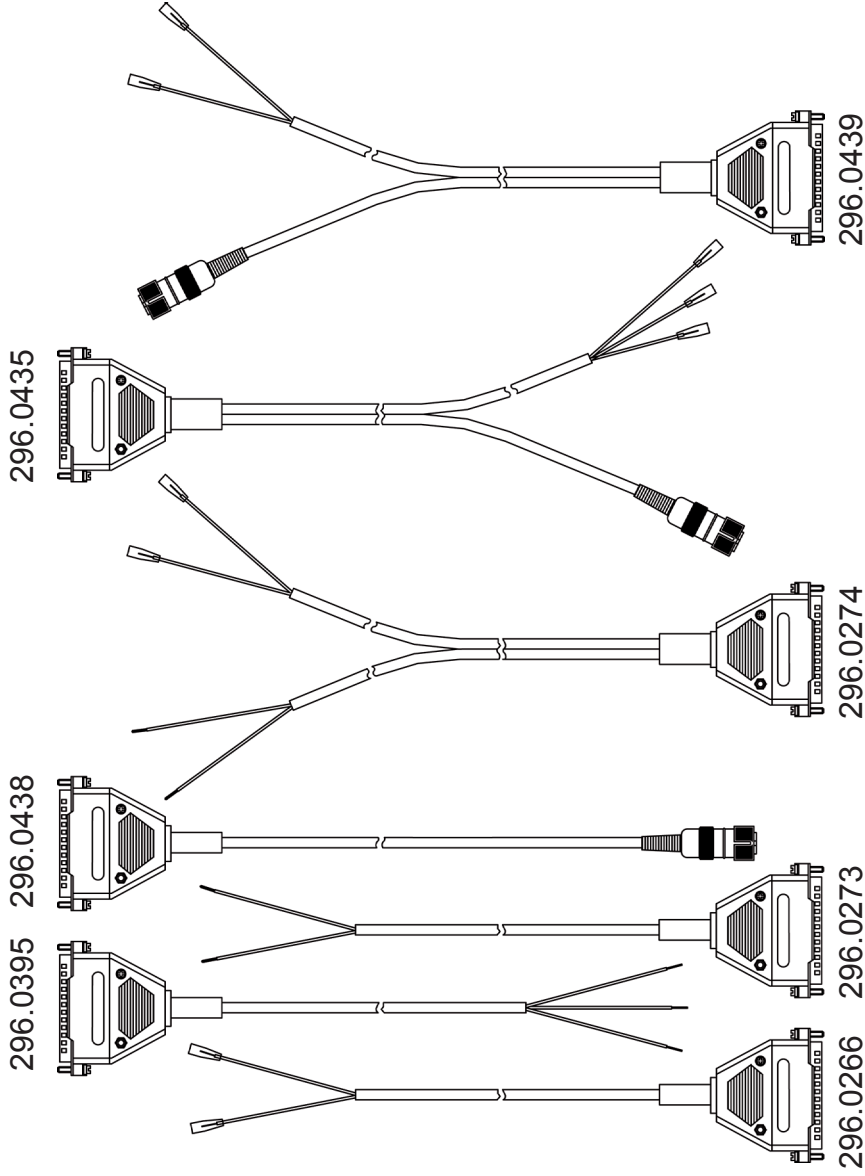

Bl.Nr. **348.23.15** **STROBEL**

Teile Nr.	Benennung
	Für DC1500-ST220A Nähtrieb
296.0448	Kl. 218D-TP, 325-40D-TP: Anschlussleitung für Lüftung und Taucher
296.0655	Kl. 560 ab Ausf. 2: Anschlussleitung für Lüftung, Fadenabschneider und Fadenzieher

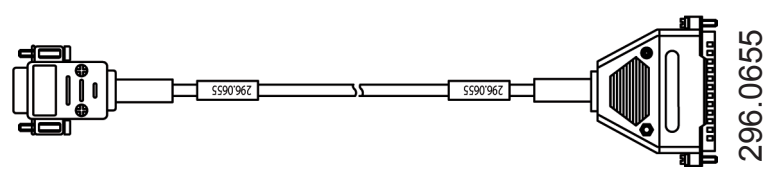
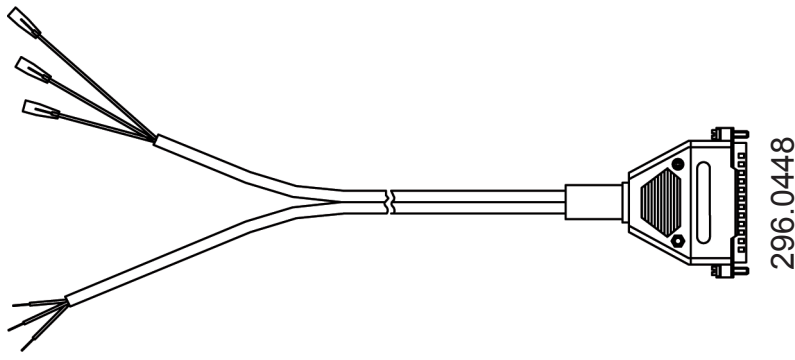

Änderungen vorbehalten

Teile Nr.	Benennung
178.0009 296.0348	Spanplattenschraube 5x30 Netzanschlusskabel
397.0256	KI. 103-258M(B): Netzschalter Typ: NS108
497.0256	KI. 560-21: Netzschalter Typ: NS108
597.0256	KI. VTD410EV-SEPC1: Netzschalter Typ: NS108

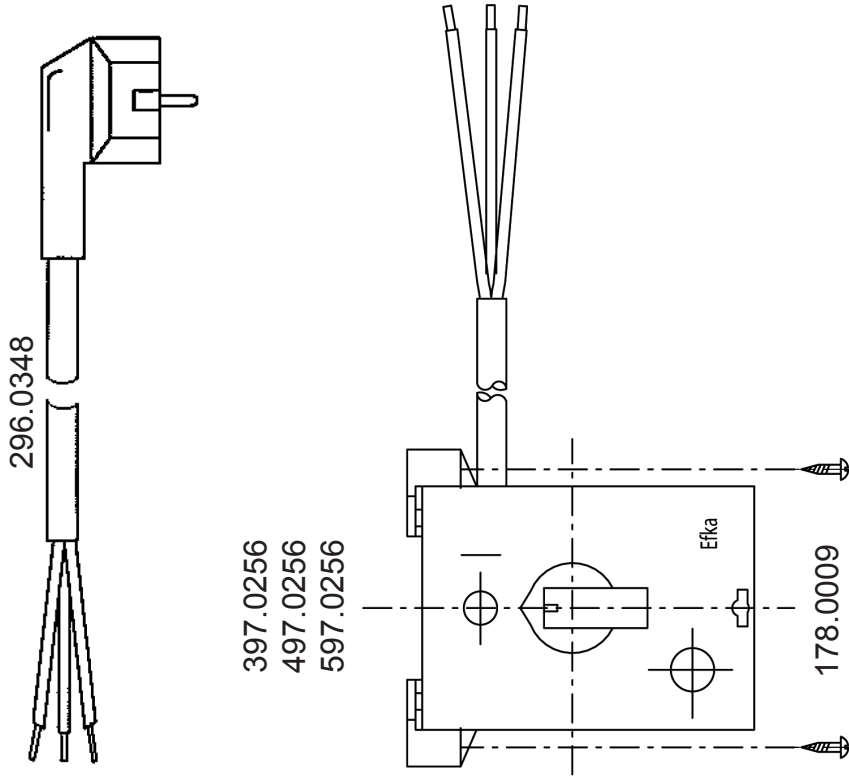

Teile Nr.	Benennung
296.0643	Für DC1500-Nähantrieb
296.0644	Verlängerungsleitung für Netz DC... ca. 1000 mm lang Verlängerungsleitung für Kommutierungsgeber DC... ca. 1000 mm lang

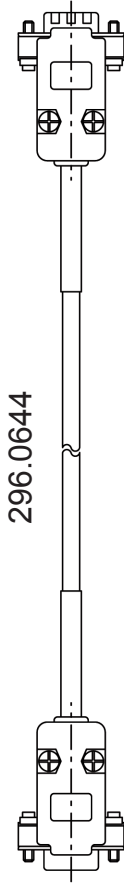
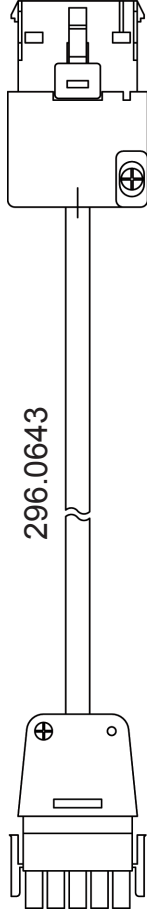

Teile Nr.	Benennung
498.0560	Für DC1500-ST220A Nähantrieb
	Efka dc Nähantrieb kpl. bestehend aus:
116.0517	Befestigungswinkel f. Sollwertgeber
233.0846	Zugstange kpl (400 - 700 mm)
164.0003	Federscheibe
171.0505	Zylinderschraube m. Iskt. M5x10
178.0077	Spanplattenschraube 5x25
298.0560	dc Grundmotor DC1500
298.0627	Steuerkasten ST220A-N201
298.0562	Sollwertgeber EB301A
178.0055	Spanplattenschraube 4x20
192.0004	Warnschild
293.0080	Schuko-Stecker
293.0088	Kabelschelle
293.0089	ISO-Druckschelle
293.0209	Kabelschelle
293.0722	Kabelbinder
293.0930	Kabelschelle
298.0542	Bedienteil V810
171.0501	Kl. 218, 310, 325, 327, 3100, 560:
293.0971	Zylinderschraube m. Iskt. M5x12
	Kabelschelle

Änderungen vorbehalten

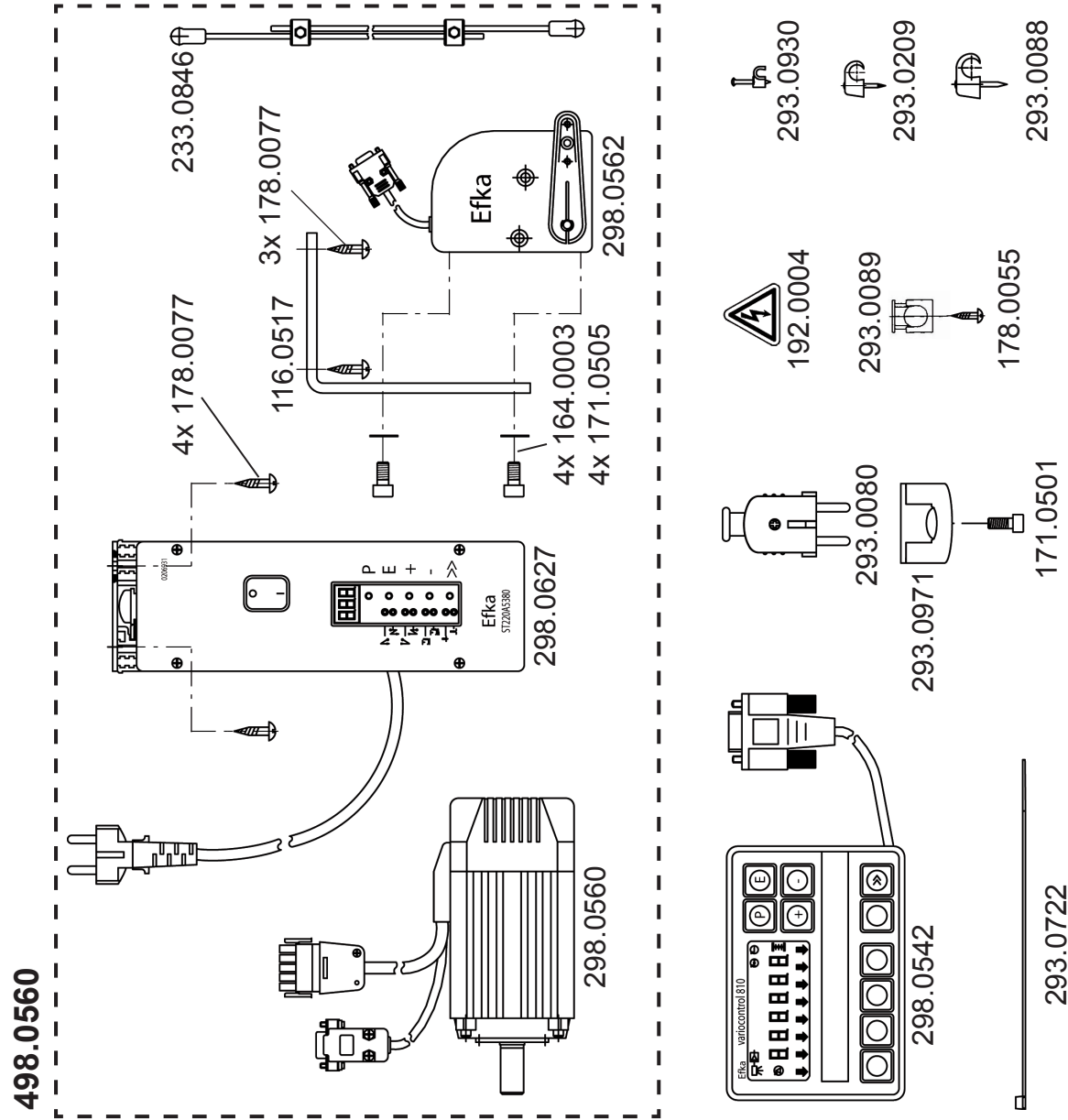

Bl.Nr. **351.23.53**

Teile Nr. Benennung

Für DC1500 Nähtrieb

Untertischmontagesatz: DC 15..
bestehend aus:
Befestigungsfuss mit Masseklemme,
Lasche kpl., Riemenschutz kpl.,
2 Rechteckmuttern, Satz Schrauben,
Keilriemenscheibe Ø58

Federring 8,1
Scheibe R9
Sechskantschraube M8x35

Kl. 141, 142:
Keilriemen 10 x 1000

Kl. 103-258:
Keilriemen 10 x 850

298.0626

164.0046
169.0035
173.0803

141.0013

141.0027

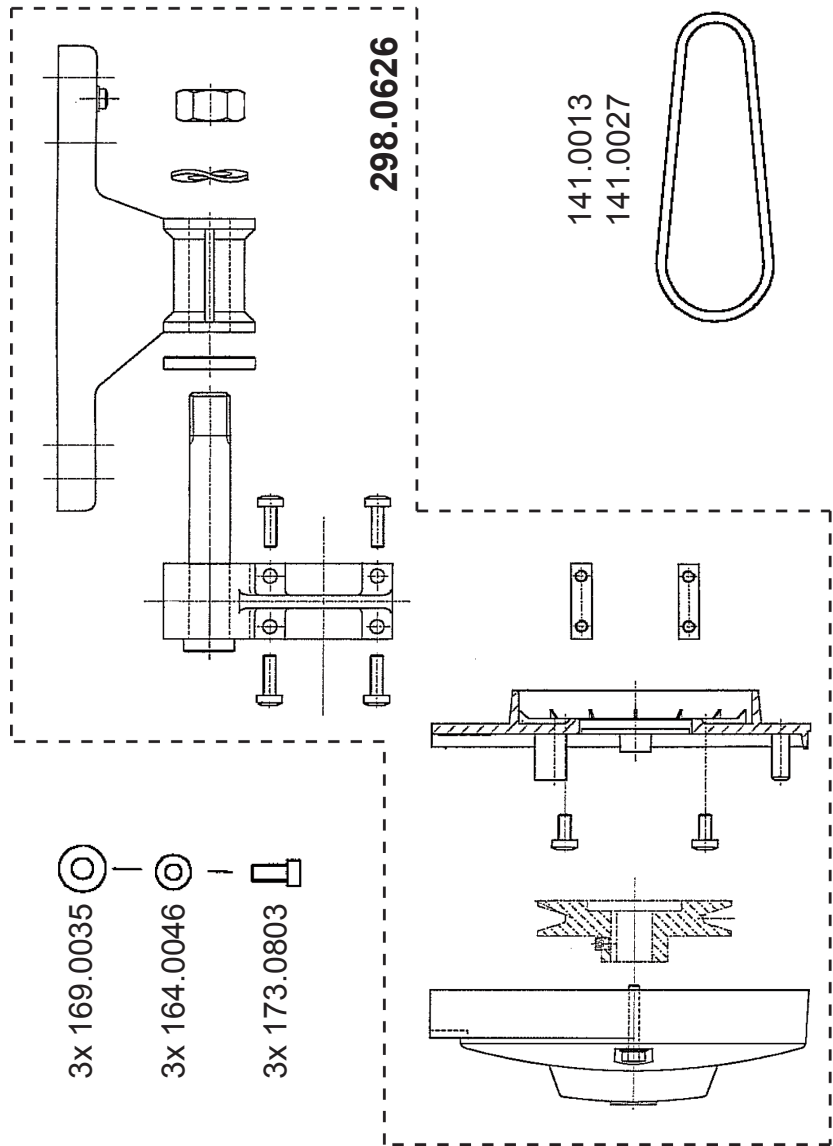

Teile Nr.	Benennung
	Für DC1500 Nähhantrieb
240.0220	Kl. 45, 58, 103, 120, 170, 174, 560: Zahnscheibe z=38 (mit 175.0602)
240.0228	Kl. 180, 218, 310, 325, 327, 3100: Zahnscheibe z=24 (mit 175.0602)
140.0223	Kl. 58, 103, 120, 170, 174, 560: Zahnriemen Lw=400
140.0224	Kl. 45: Zahnriemen Lw=350
140.0229	Kl. 180, 218, 310, 325, 327, 3100: Zahnriemen Lw=375

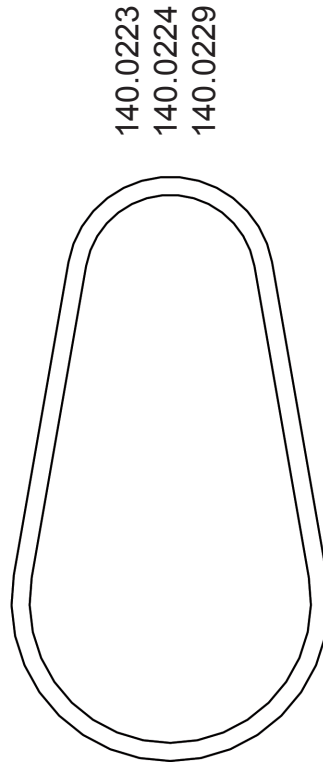
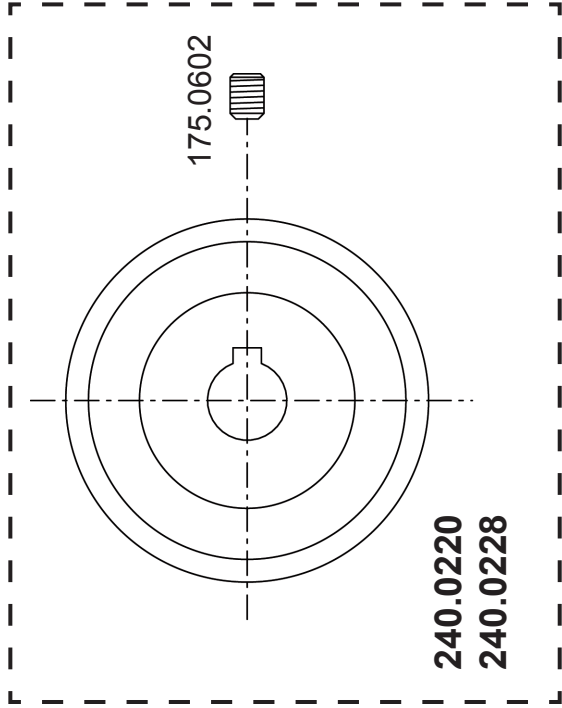

Teile Nr.	Benennung
	Für DC 1500/DC1550 Nähantrieb
298.0620	Impulsgeber Typ: IPG 001
	Kl. 120:
244.0299	Flansch kpl. bestehend aus:
144.0299	Flansch
175.0515	Gewindestift M5x5
	Kl. 120, 310, 3100, 3200:
175.0609	Gewindestift M6x50
169.0033	Scheibe 6,4
179.0628	Sechskantmutter M6
	Kl. 218, 325, 327:
133.0784	Gewindestange M6x105
169.0033	Scheibe 6,4
179.0628	Sechskantmutter M6
	Kl. 103-258, 141, 142:
133.0395	Stange Ø6x130
	Kl. 180:
133.0894	Stange
179.0628	Sechskantmutter M6
	Kl. VTD410EV/-SEPC1:
175.0609	Gewindestift M6x50
169.0033	Scheibe 6,4
179.0628	Sechskantmutter M6

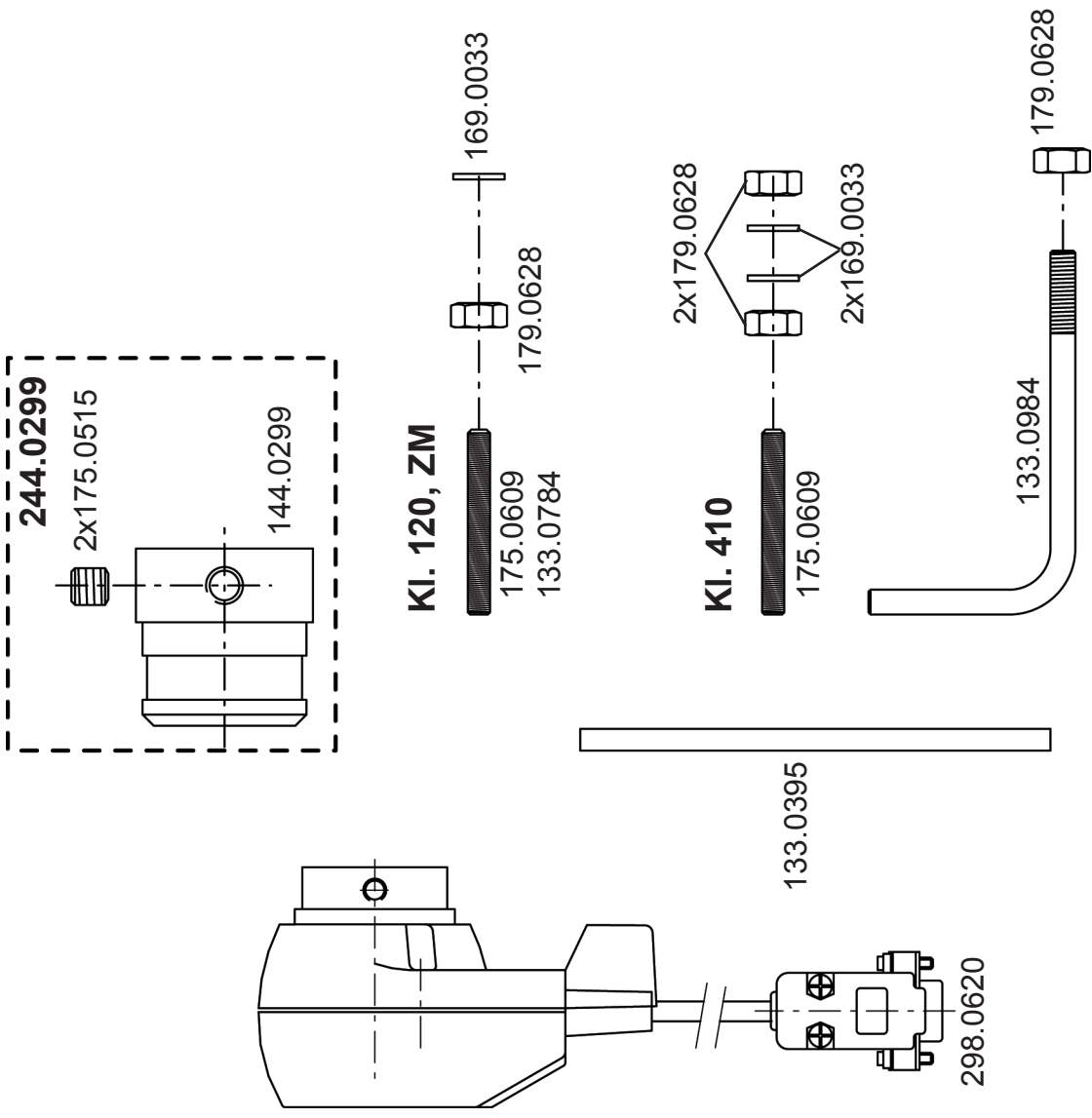

Änderungen vorbehalten

Masse-Anschluss Oberteil

Kl. allg.

193.0982

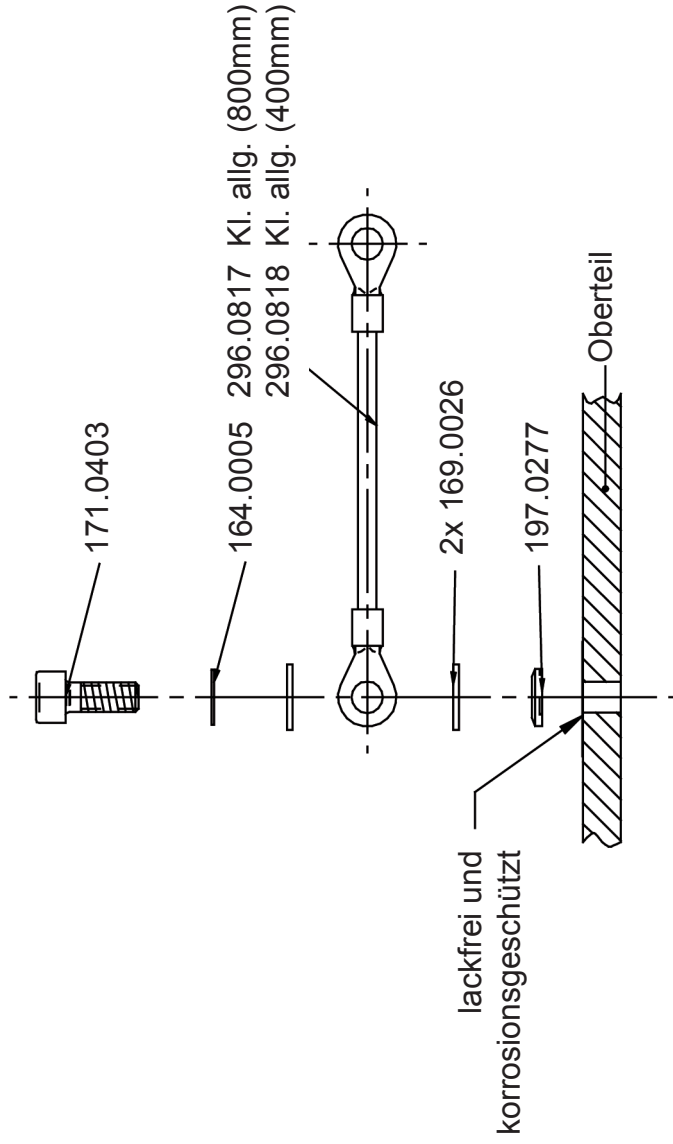

STROBEL

Bl.Nr. 351.24.11

Teile Nr.	Benennung
164.0005	Federring
169.0026	Scheibe B4,3
171.0403	Zylinderschraube m. Iskt. M4x10
193.0982	Massezeichen
296.0817	Masse-Anschlussleitung (grau/Länge: 800 mm)
296.0818	Masse-Anschlussleitung (grau/Länge: 400 mm)
197.0277	Kontaktscheibe

Änderungen vorbehalten

PE-Anschluss Oberteil

Kl. 103-258

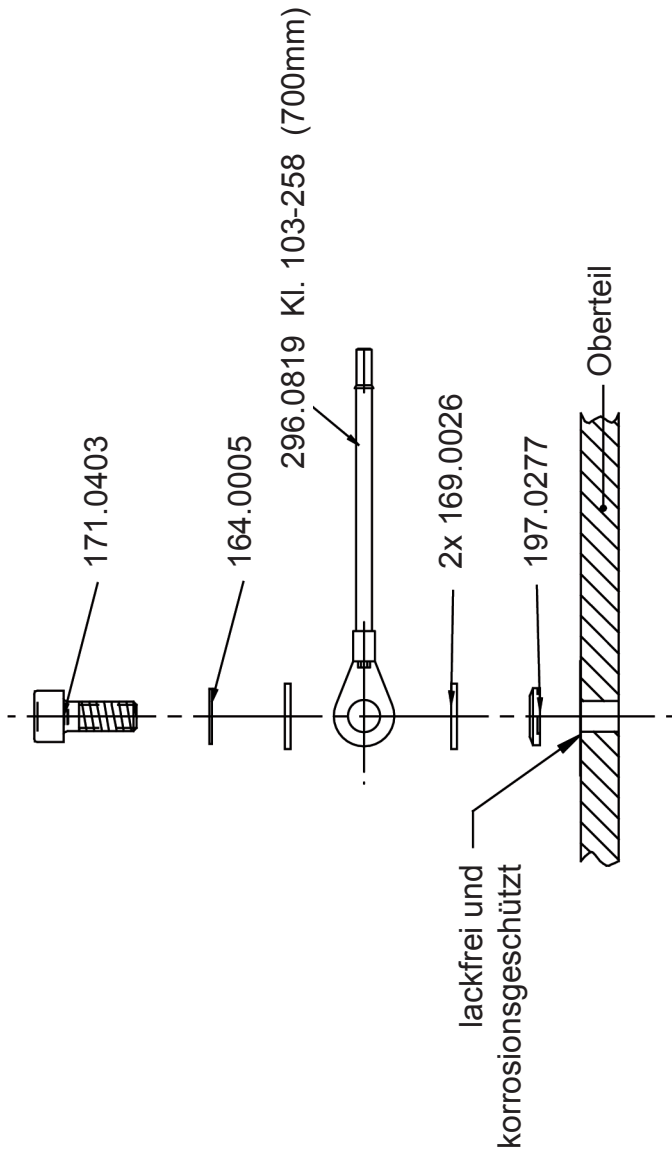
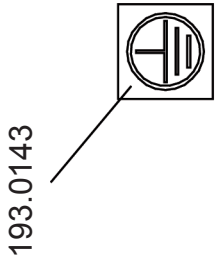

STROBEL

Bl.Nr. 351.24.12

Teile Nr.	Benennung
164.0005	Federring
169.0026	Scheibe B4,3
171.0403	Zylinderschraube m. Iskt. M4x10
193.0143	Schutzleiterzeichen
296.0819	PE-Anschlussleitung (grün-gelb/Länge: 700 mm)
197.0277	Kontaktscheibe

Änderungen vorbehalten

Und wir können noch mehr für Sie tun!

Unser Lieferprogramm bietet für jede Branche und jegliche Anforderung genau die richtige Problemlösung.

And we can do a lot more for you!

Our range offers the correct problem solution for every branch and for all requirements.

■ Für die Bekleidungsindustrie:

Ein- und Zweifaden-Hochleistungs-Saummaschinen

Doppelblindstich-Saummaschinen

Zweifaden-Blindstich-Staffiermaschinen

Roll- und Flachpikiermaschinen

Pikier-Automat

und

weitere Spezial-Nähmaschinen

■ *For the clothing industry:*

Single and two thread high performance hemming machines

Bluff edge hemming machines

Two thread blind stitch felling machines

Roll and flat padding machines

Automatic lapel padding machine

and other special sewing machines

■ Für die Schuhverarbeitung:

Einfaden-Überwendlichmaschinen mit und ohne Differentialtransport

■ *For the shoe industry:*

Single-thread overseaming machines with and without differential feed

■ Für Kürschnereien und Pelzkonfektion:

Pelzschnellnäher

Pelzpikiermaschine

Futterstaffiermaschine

■ *For the fur industry:*

Rapid fur sewing machines

Fur padding machine

Lining felling machine

■ Für Heimtextilien:

Ein- und Zweifaden-Blindstichmaschinen

■ *For the home textiles industry:*

Single and two thread blind stitch machines

■ Für die Polsterverarbeitung:

Ein- und Zweifaden-Überwendlichmaschinen

Ein- und Zweifaden-Blindstichmaschinen

■ *For the upholstery industry:*

Single and two thread overseaming machines

Single and two thread blind stitch machines

■ Für die Konfektion technischer Textilien:

Ein- und Zweifaden-Überwendlichmaschinen

■ *For the processing of technical textiles:*

Single and two thread overseaming machines

Noch Fragen?

Dann rufen Sie uns an, schreiben Sie uns oder kommen Sie einfach bei uns vorbei.

Sie können jederzeit weitere Informationen über unsere Produkte anfordern oder die Strobel-Nähmaschinen in unserem Ausstellungsraum live erleben. Wir freuen uns auf Sie!

Any further questions?

Then phone, write or simply come and see us. You can have further information about our products at any time, or experience the Strobel machines live in our show room. We're looking forward to meeting you!

STROBEL

Spezialmaschinen GmbH

Postfach 1242
82168 Puchheim
Siemensstraße 3
82178 Puchheim
DEUTSCHLAND

www.strobel.biz
Telefon: +49 89 80096-0
Telefax: +49 89 80096-190