

**GLOBAL**

---

**INDUSTRIAL SEWING MACHINES**

**MODEL BM-210**  
**BLINDSTITCH MACHINES**

**PARTS BOOK**  
**INSTRUCTION MANUAL**

## INDEX

1. Setting up Machine for Work .....	2
A. Location .....	2
B. Installing Thread Stand .....	2
C. Connecting Motor Controller .....	3
D. Assembly of Knee Lifter .....	4
2. Lubrication .....	4
3. Needles and Thread .....	5
4. Replacing the Needle .....	6
5. Threading Machine .....	6
6. Inserting the Work Piece and Starting to Sew .....	8
7. Adjustment of Thread Tension .....	9
8. Regulating Stitch Length .....	10
9. Adjustment of Needle Penetration .....	10
10. Removal of the Work from the Machine .....	11
11. Skip Stitch Device .....	12

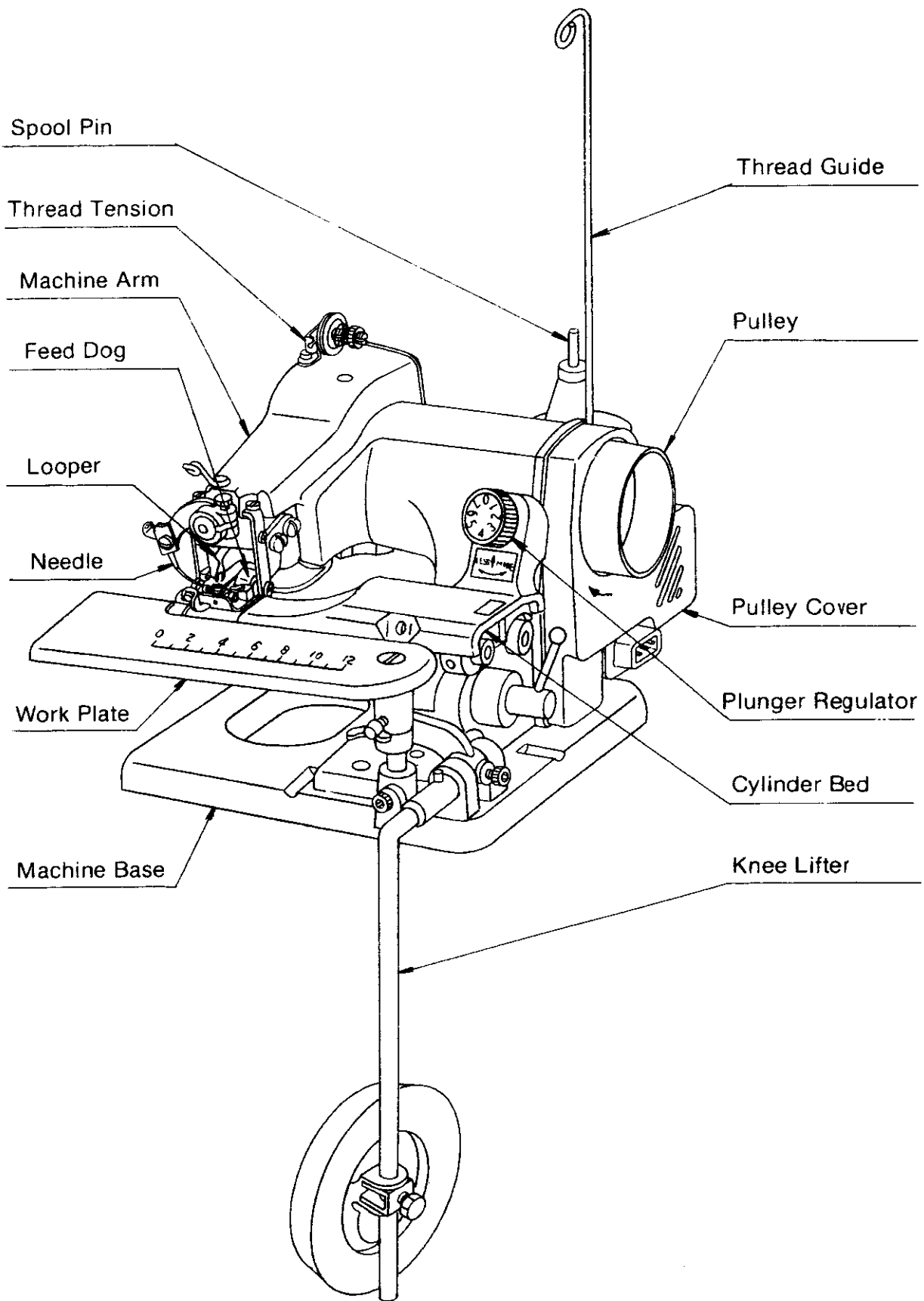

## 1. Setting up Machine for Work

Unpack machine from its shipping box, making certain that you remove from box all component parts and accessories.

### A. Location (Figs. 1—2)

Place machine on a firm table, preferably near its right front corner. Attach machine near edge of table using table clamp which is included with the accessories. Table clamp is inserted into groove in base plate of machine either from front or right side.

The selection of the clamp groove depends on how you desire to place machine on table to suit your own convenience. Make sure machine is clamped tightly to keep it from falling off table. See Figs. 1 and 2 for details of clamping.

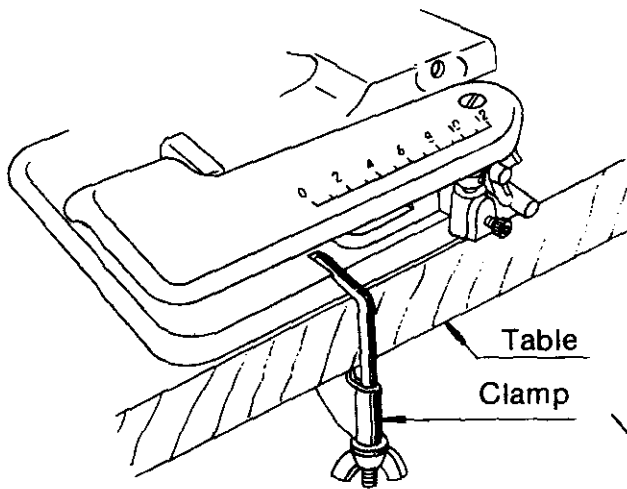

Fig. 1

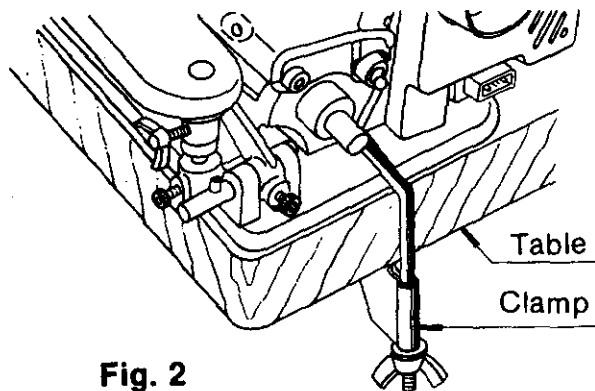
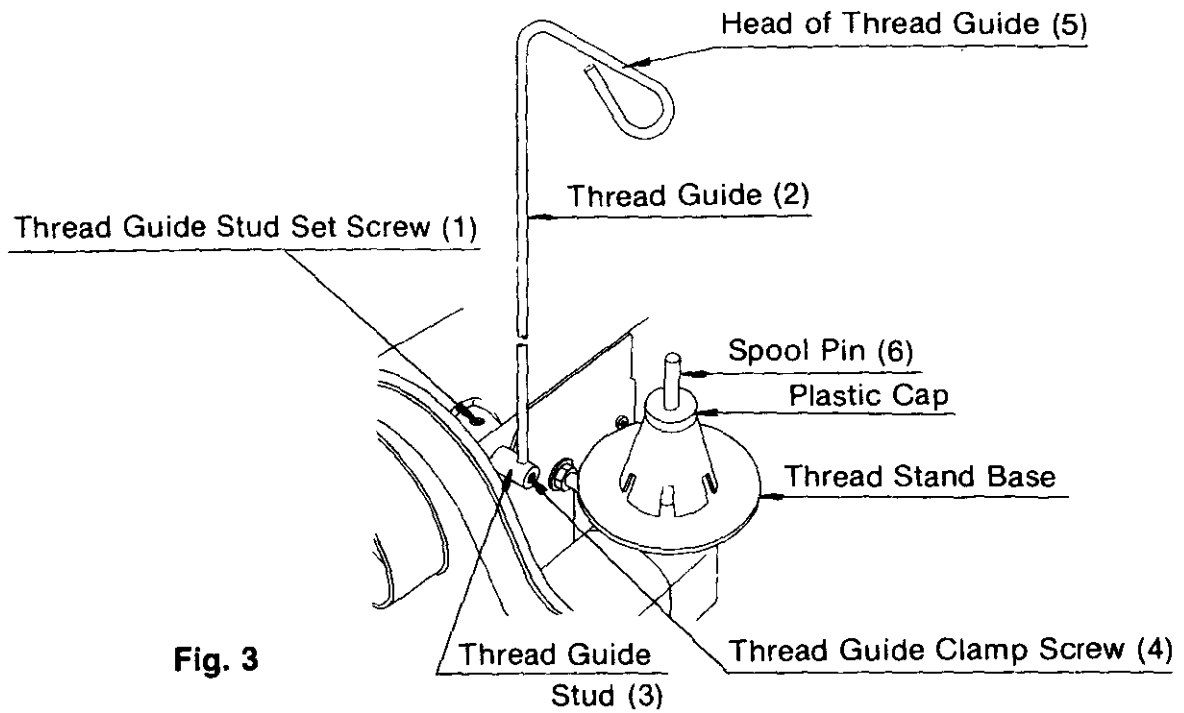

Fig. 2

### B. Installing Thread Stand (Fig. 3)

First, loosen thread guide stud set screw (1) and insert thread guide (2) and stud (3) assembly into the hole at rear of machine. Then, tighten set screw (1).

And loosen clamp screw (4), and adjust head (5) of thread guide to face the direction of spool pin (6). Then, tighten clamp screw (4).

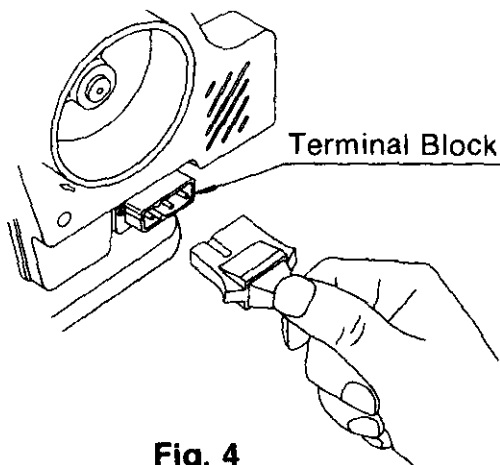

**Fig. 3**

### C. Connection Motor Controller (Figs. 4—5)

Insert three-hole plug on controller wiring into terminal block at right side of machine and insert standard plug into wall outlet.

Place controller on floor and regulate speed of machine by stepping on foot pedal.



**Fig. 4**

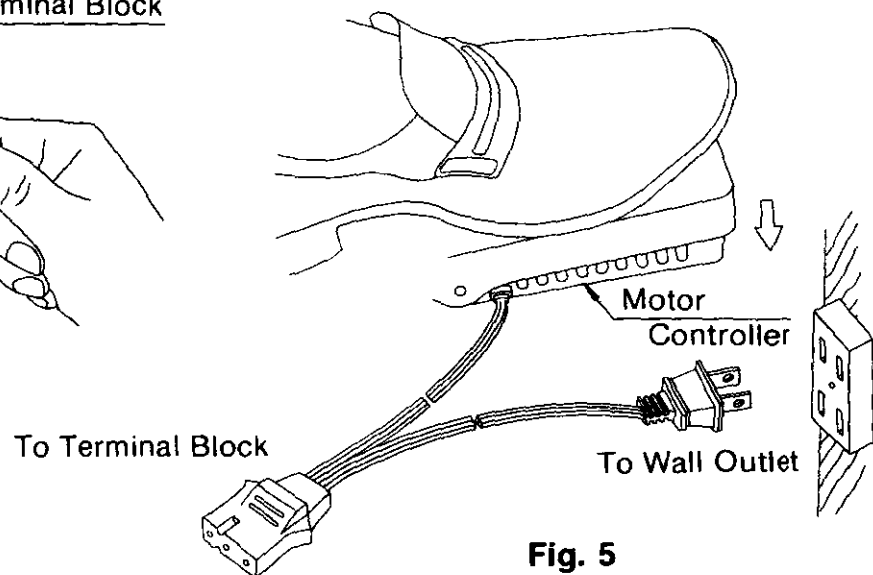
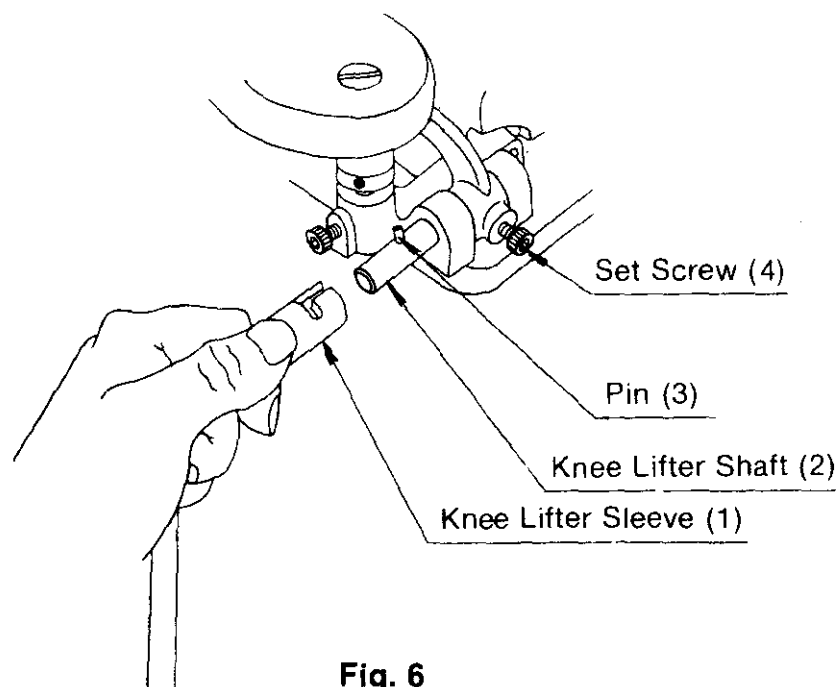

**Fig. 5**

#### D. Assembly of Knee Lifter (Fig. 6)

Push sleeve (1) onto free end of shaft (2) and allow pin (3) to enter L-shaped groove in sleeve.

In case of adjusting the angle of knee lifter, loosen the set screw (4) and adjust the knee lifter to the suitable angle. Then, tighten the set screw (4).



#### 2. Lubrication (Fig. 7)

Lubrication is important for the trouble-free operation and long service life of the machine. Therefore, after setting-up machine as per paragraph 1, drop a sewing machine oil into all the holes indicated by arrows on Fig. 7, and also drop oil onto the inner moving parts after opening the side cover and rear cover of machine.

Daily and before operating machine, place one or two drops of sewing machine oil into all the oil holes indicated by arrows on Fig. 7.

To assure clean operation, it is suggested that oiling be done upon completion of the work. This will allow excess oil to drip off and only the needed quantity will remain. Be certain to wipe off machine all excess oil before starting to work. Also before sewing, operate machine for about a minute or so with the knee lifter depressed to eliminate all excess lubricant.

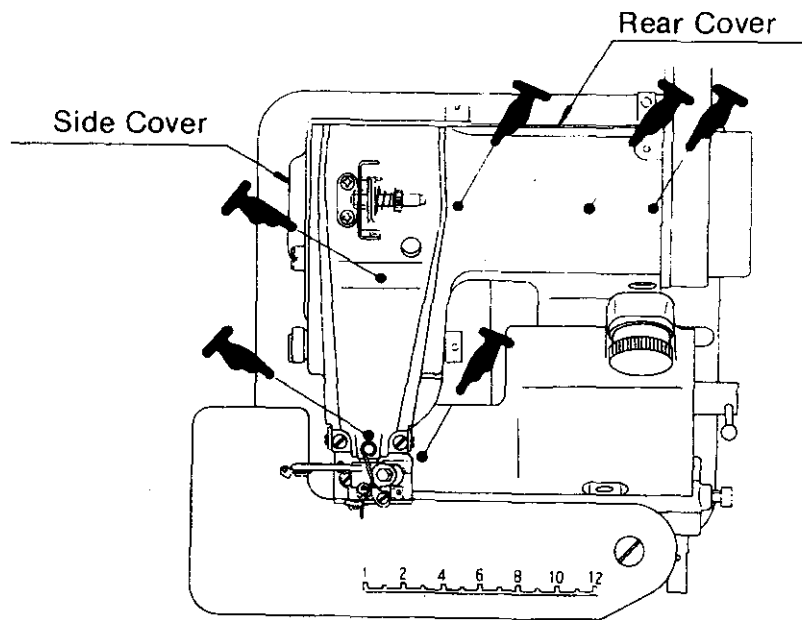

**Fig. 7**

### 3. Needles and Thread

The recommended needle is system LW x 6T (or style 29—43) Blindstitch Machine Needle. Size range from No. 3 to 4.

To assure satisfactory operation needles, thread and fabric must be matched as suggested in the table below:

NEEDLE	THREAD	MATERIAL
size 3 (11)	No. 80—100	Nylon sliik and other light weight fabrics
size 3 1/2 (14)	No. 60—70	Cotton, woolen, and other medium weight fabrics
size 4(16)	No. 50—60	Thick woolen and other thick weight fabrics

#### 4. Replacing the Needle (Fig. 8)

Turn handwheel away from you (clockwise direction) until needle reaches to the end of its return stroke. Remove needle to be replaced by loosening needle clamp screw (1) about two turns.

Insert new needle into its seat on needle carrier (2) pushing it as far to the left as it will go. Now, tighten needle clamp screw (1).

Note: Fig. 8 shows needle carrier and its part in a disassembled view.

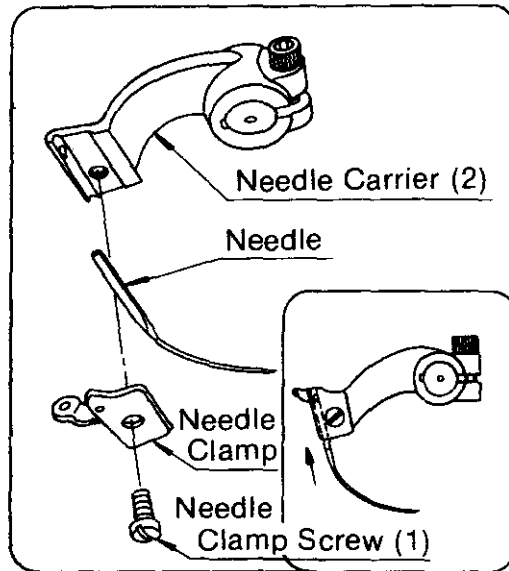

Fig. 8

#### 5. Threading Machine (Figs. 9—12)

A. When using sewing thread from a cone, place it over plastic cup on thread stand (Fig. 9)

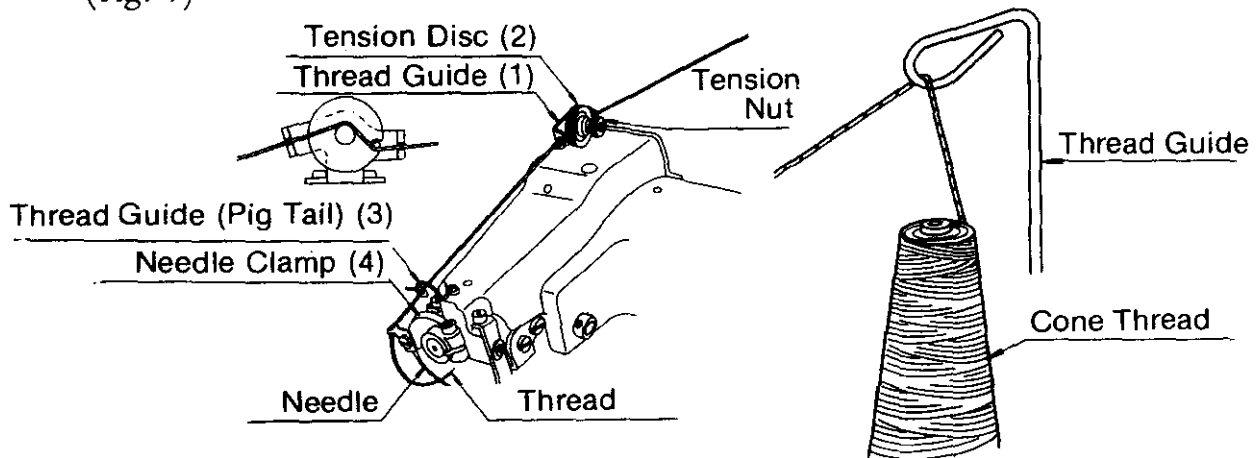
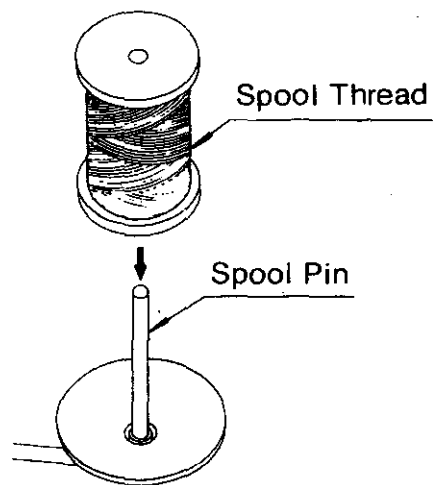

Fig. 9

B. When using spool thread, remove plastic cup before placing spool on thread stand (Fig. 10).

C. For correct threading of machine, follow carefully course of thread as shown on Fig. 9.

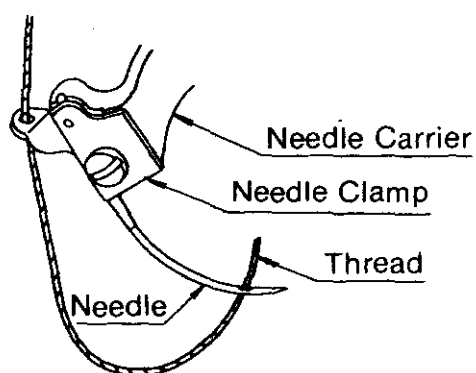

**Fig. 10**

When reaching to thread tension device, enter thread first in rear eye of thread guide (1). Then, lead thread between the two tension discs (2) as per Fig. 9. Now enter it from behind through the front eye of thread guide. Lead thread forward to front of machine. Enter thread from above into thread guide (3), and eyelet of needle clamp (4).

As this point, make certain that needle is in extreme left-hand position. Now pull thread through needle eye from below as shown in Fig. 11.

It is easier to pull thread through needle eye when work plate is opened by loosening the clamp screw (Fig. 12).



**Fig. 11**

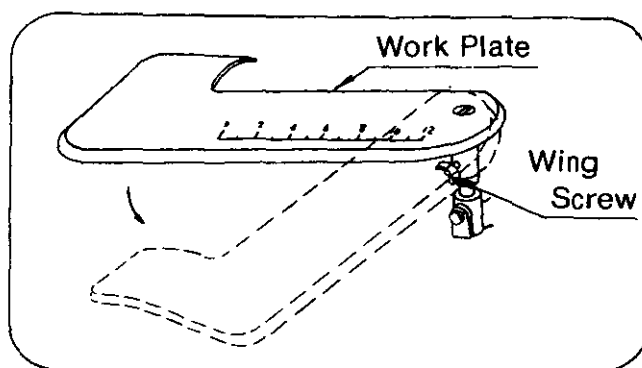

**Fig. 12**

## 6. Inserting the Work Piece and Starting to Sew (Figs. 13—14)

Depress knee lifter. This causes the cylinder bed of the machine to swing downward and creates a gap between the presser foot and the cylinder bed. Insert the work in the gap just opened in such a manner that the folded or sewn edge of the article is alongside the edge guide of the presser foot.

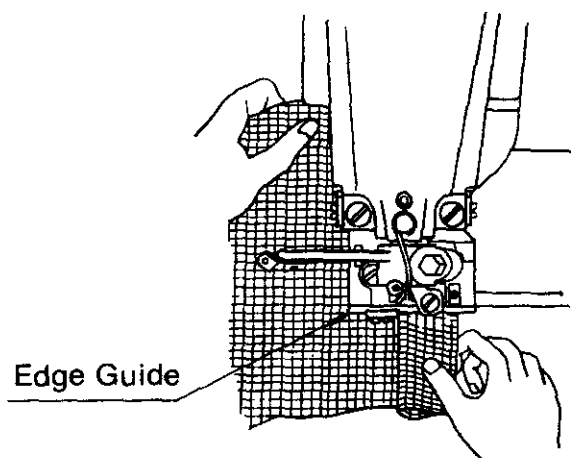

Fig. 13

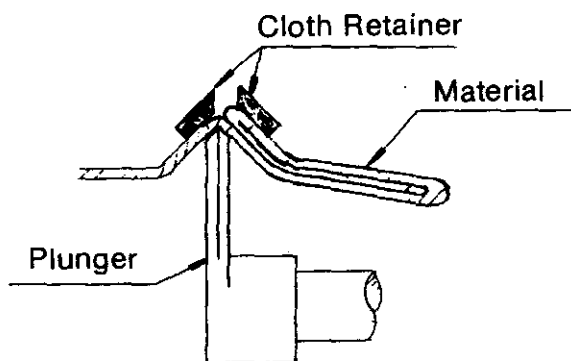

Fig. 14-1

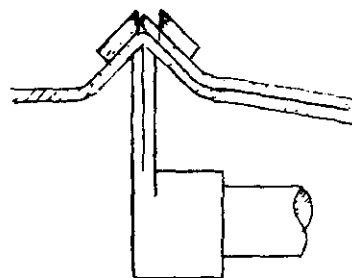

Fig. 14-2

When the article is in proper position, completely release the knee lifter. Get the machine started slowly and watch the material pass edge guide rather than to observe the action of the needle.

In case of sewing double folded edge of material, insert the material as per Fig. 14-1. In case of sewing single folded, insert the material as per Fig. 14-2.

## 7. Adjustment of Thread Tension (Figs. 15—16)

Different kinds and weights of material and the various sizes of thread require respective thread tensions. Thread tension is regulated by turning the tension nut located at the top of the machine arm.

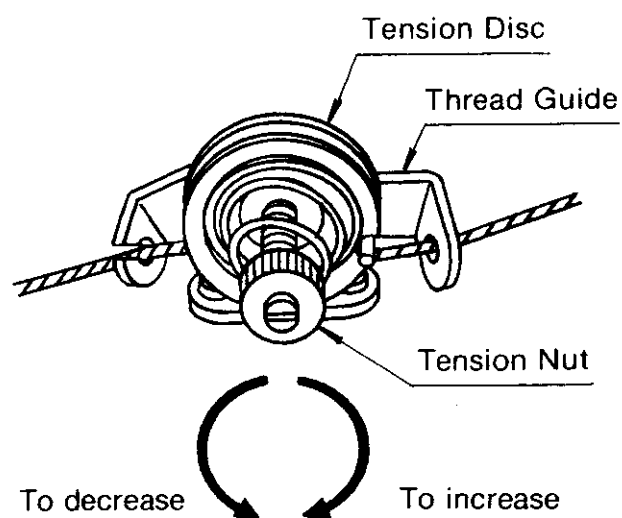

Fig. 16

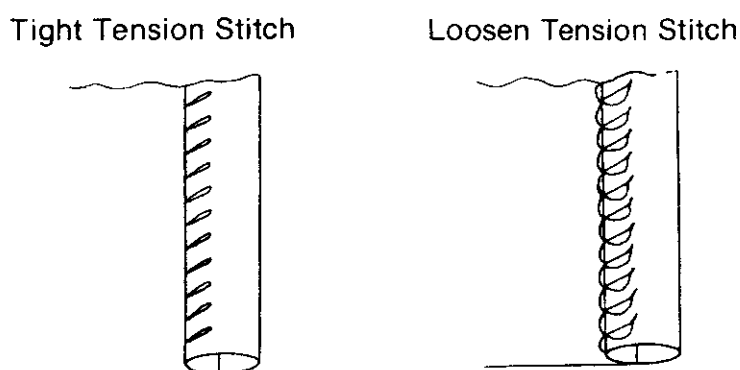

Fig. 15

To increase thread tension, turn the nut away from you (clockwise).  
To decrease the tension, turn the nut towards you (counter-clockwise).  
Do not turn, tighten, or loosen tension more than about one quarter turn at one time.

Test for results and readjust, if necessary.

## 8. Regulating Stitch Length (Fig. 17)

Open side cover by loosening two clamp screws. Loosen two set screws (1) in stitch regulating collar (2), and turn collar (2) until desired number is reached by indicator groove (3) of eccentric. Then, tighten screws (1) securely.

When delivered from our factory, the number for stitch length of the machine is set to be at "6".

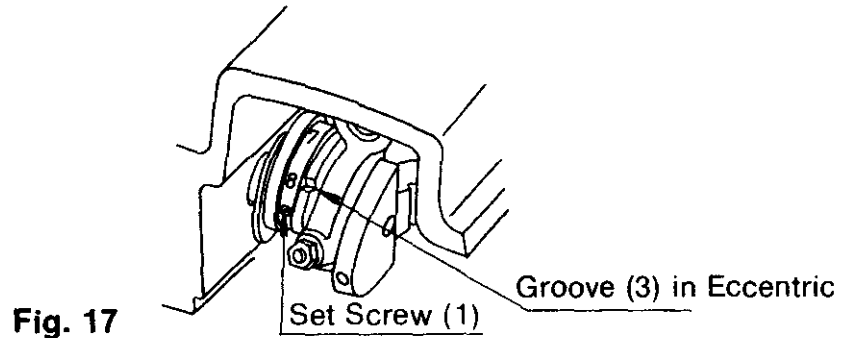

Each number shows the following stitch length.

Number on collar	4	5	6	7	8
Stitch length (M/M)	4	5	6	7	8

To have best choice of stitch length, recommend to have a few trial stitching on different kind materials.

## 9. Adjustment of Needle Penetration (Fig. 18)

The depth of needle penetration into the cloth can be adjusted by turning the plunger regulator located on front of the machine.

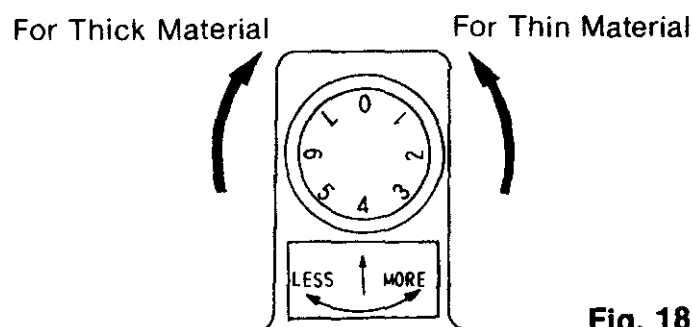

To increase needle penetration for light materials, turn the regulator counter-clockwise. The greater the number directly in front on the regulator dial, the deeper the penetration of the needle. To lessen the penetration for thick materials, turn regulator clockwise.

To prevent damage to the needle and the machine, it is recommended to begin sewing with the least degree of penetration, and to sew a short length of seam. Check for catching of the material and appearance, making whatever penetration adjustments are required until stitching is as desired.

NOTE: Beginning and end of penetration adjustments are controlled by built-in stops. Do not force beyond its stops.

## 10. Removal of the Work from the Machine (Fig. 19)

Stop machine and turn handwheel away from you until needle is completely out of the material (at highest position). Press knee lifter to the right and pull the work piece rearward out of the machine with a quick stroke. This will lock the last stitch and break the thread.

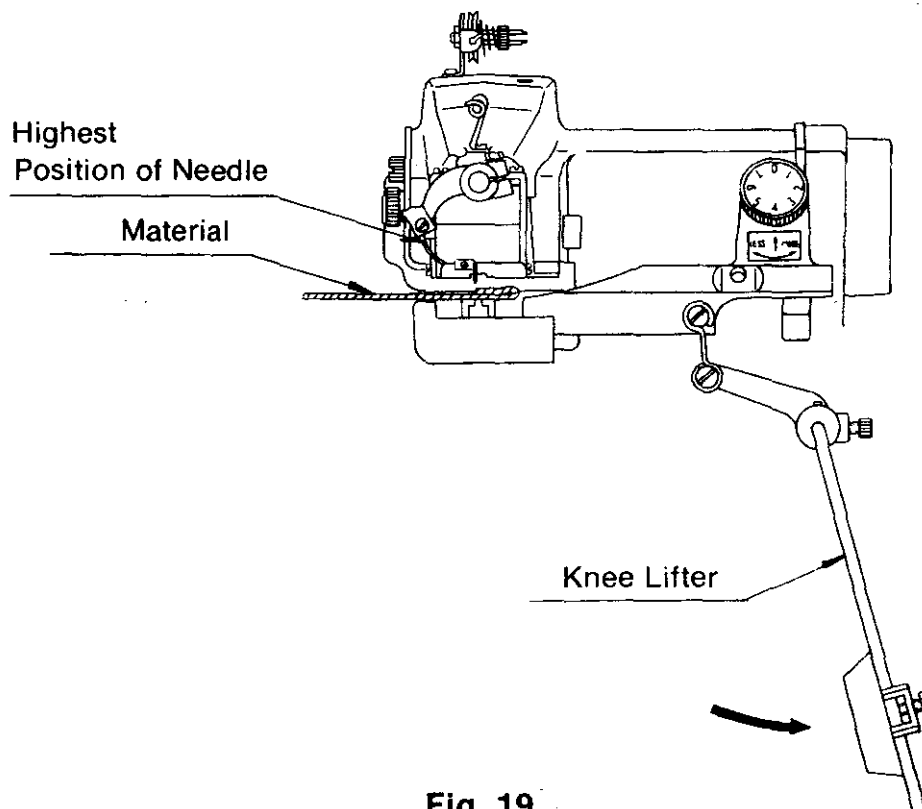

Fig. 19

## 11. Skip Stitch Device (Figs. 20—21)

The position of the lever at the right side of the machine controls the skipstitch device. When this lever points towards “No skip”, the needle catches the material at every stitch. Pointing towards “skip”, the needle penetrates the material at every other stitch.

To be assured that the machine works as desired, the lever should be pushed in either direction until stopped. If the lever is maintained at intermediate positions, operation of the machine is not reliable. Also note that every time operation is changed from skip to non-skip, needle penetration should be checked and readjusted, if necessary.

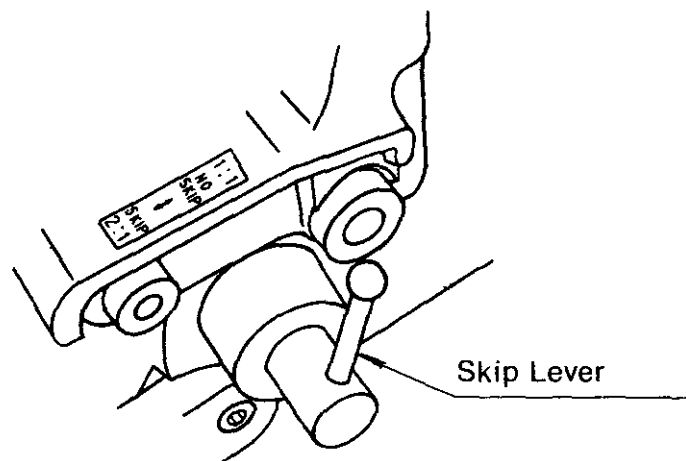

Fig. 20

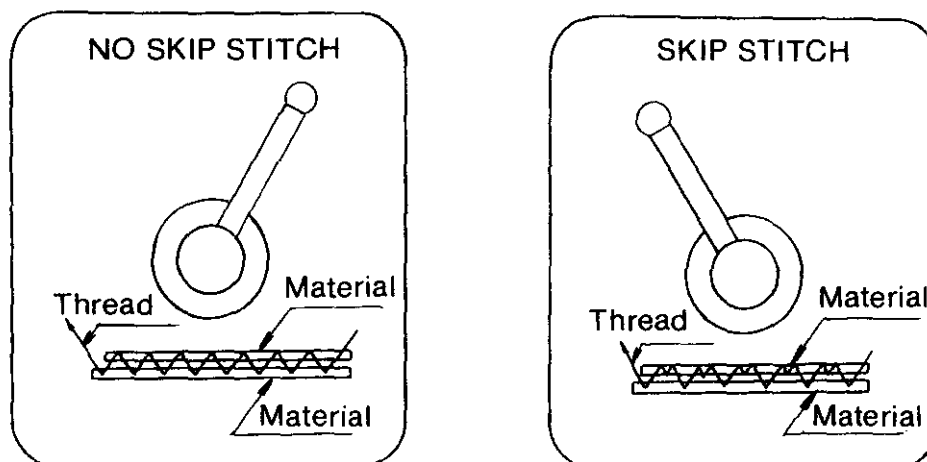
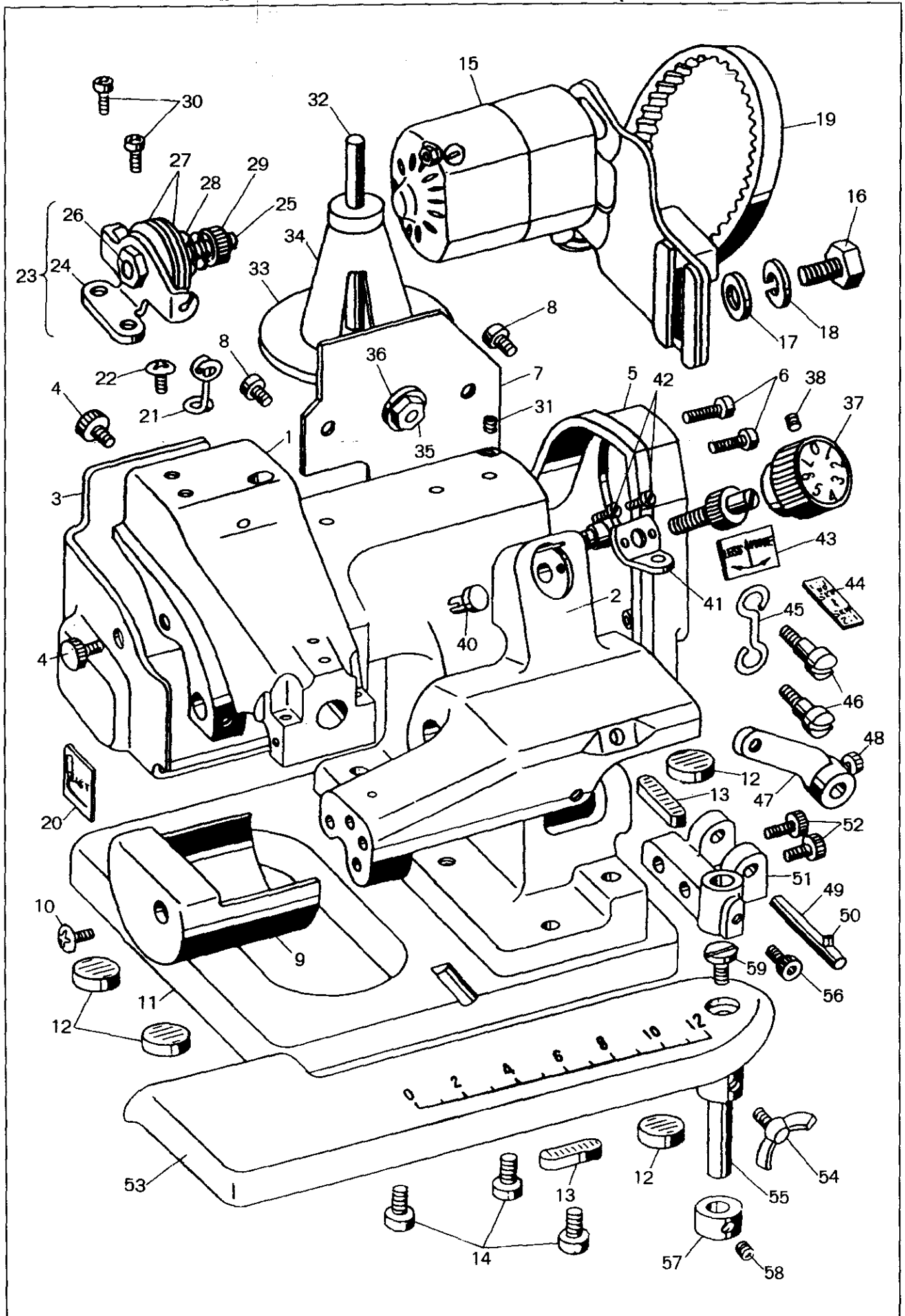
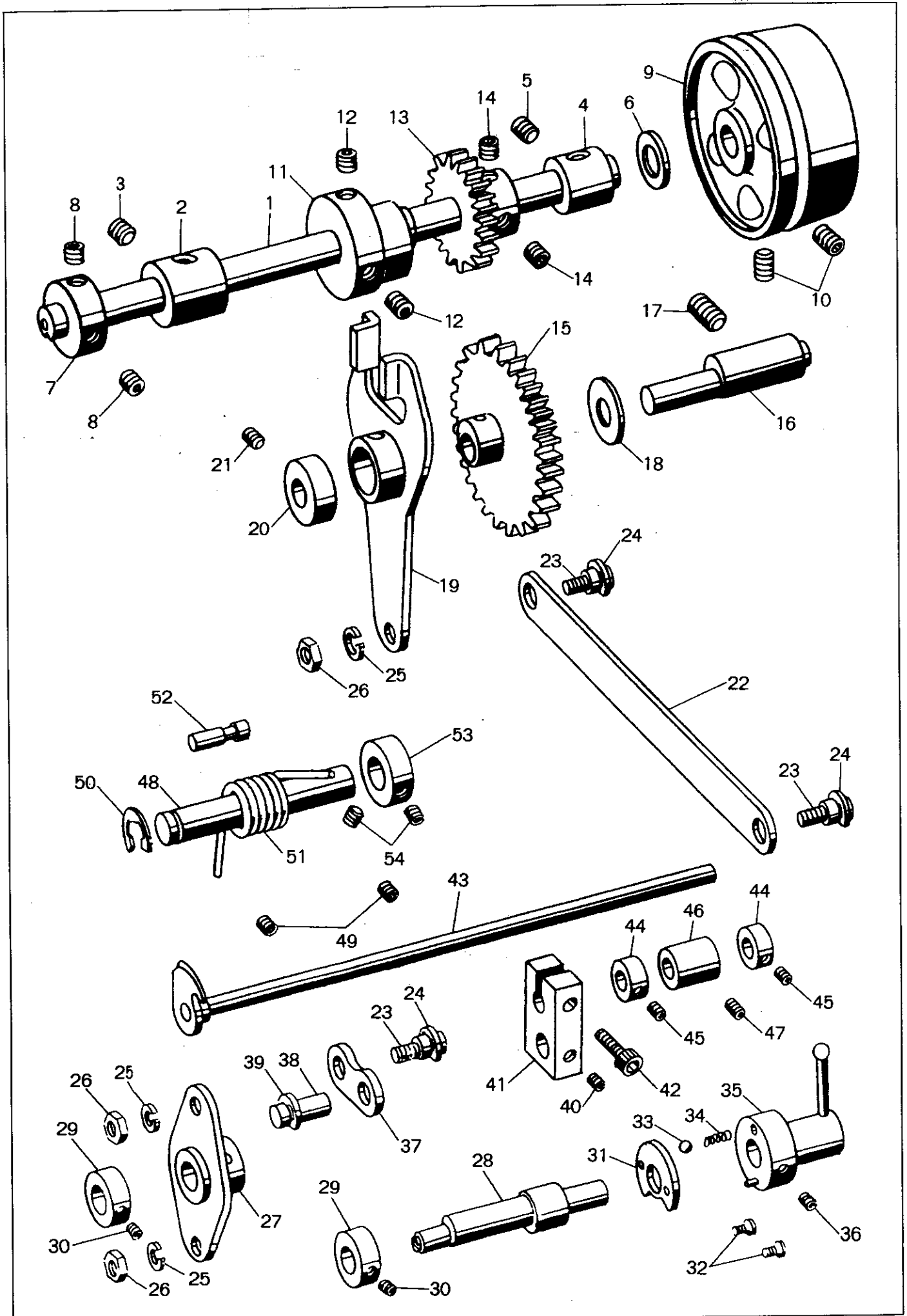

Fig. 21

# PARTS LIST



Ref. Nos.	Parts No.	Description
1	21001	Machine Frame
2	21002	Cylinder Bed
3	21003	Arm Side Cover
4	21004	Arm Side Cover Clamp Screw
5	21005	Pulley Cover
6	0144016	Pulley Cover Set Screw
7	21006	Arm Rear Cover
8	0144008	Arm Rear Cover Set Screw
9	21007	End Cover
10	0174008	End Cover Set Screw
11	S-21008-G	Machine Base with Rubber Cushion (Moss-Green)
11	S-21008-R	Machine Base with Rubber Cushion (Wine-Red)
12	21009	Rubber Cushion (A)
13	21010	Rubber Cushion (B)
14	0186016	Machine Base Clamp Screw
15	10109-A	Motor
16	B-005	Motor Bracket Set Screw
17	B-006	Motor Bracket Spring Washer
18	B-007	Motor Bracket Spring Washer
19	21101	Motor Belt
20	10131	Needle System Label (LW x 6T)
21	4135	Thread Guide (Pig Tail)
22	0144008	Thread Guide Set Screw
23	S-21095	Thread Tension Assembly (Ref. Nos. 24-29)
24	21095	Thread Tension Bracket
25	21096	Thread Tension Post
26	4070	Thread Tension Post Nut
27	5190-A	Thread Tension Disc
28	79-B	Thread Tension Spring
29	83	Thread Tension Nut
30	0144008	Thread Tension Bracket Set Screw
31	0046006	Thread Guide Stud Set Screw
32	21093	Thread Stand
33	21094	Thread Stand Base
34	AC-101	Plastic Cap
35	11145	Thread Stand Nut
36	10543	Thread Stand Washer
37	S-10513-G	Disc Regulator (Moss-Green)
37	S-10513-R	Disc Regulator (Wine-Red)
38	6074	Disc Regulator Set Screw
39	10514	Disc Regulating Dial Screw
40	10516	Disc Regulating Dial Screw Prop
41	10515-A	Disc Regulating Plate Spring
42	8339	Disc Regulating Plate Spring Set Screw
43	21068	Disc Regulator Indicating Label
44	21037	Skip Stitch Label
45	10076-A	Cylinder Bed Connecting Hook
46	21085	Cylinder Bed Connecting Hook Screw
47	21083	Knee Lifter Crank
48	0216016	Knee Lifter Crank Set Screw
49	21084	Knee Lifter Shaft
50	10074	Knee Lifter Shaft Spring Pin
51	21082	Work Plate Bracket
52	0216016	Work Plate Bracket Set Screw
53	21081	Work Plate
54	10085	Work Plate Wing Screw
55	10082	Work Plate Shaft
56	0216012	Work Plate Shaft Set Screw
57	21023	Work Plate Shaft Collar
58	0096006	Work Plate Shaft Collar Set Screw
59	10083	Work Plate Screwed Cap



Ref. Nos.	Parts No.	Description
1	21012	Main Shaft
2	21013	Main Shaft Bushing (Front)
3	0096010	Main Shaft Bushing Set Screw
4	21014	Main Shaft Bushing (Rear)
5	0096010	Main Shaft Bushing Set Screw
6	21015	Main Shaft Thrust Washer
7	21016	Main Shaft Collar
8	0096006	Main Shaft Collar Set Screw
9	21017-G	Pulley (Moss-Green)
9	21017-R	Pulley (Wine-Red)
10	0096014	Pulley Set Screw
11	21018	Eccentric Bushing
12	0096008	Eccentric Bushing Set Screw
13	21019	Main Shaft Gear (Small)
14	0096006	Main Shaft Gear Set Screw
15	21020	Skip Stitch Gear (Large)
16	21021	Skip Stitch Gear Eccentric Shaft
17	0096010	Skip Stitch Gear Eccentric Shaft Set Screw
18	21015	Skip Stitch Gear Eccentric Shaft Thrust Washer
19	21022	Skip Stitch Gear Eccentric Shaft Fork
20	21023	Skip Stitch Gear Eccentric Shaft Collar
21	0096006	Skip Stitch Gear Eccentric Shaft Collar Set Screw
22	21024	Connecting Link (Long)
23	21025	Connecting Link/Rod Holding Screw
24	10060	Connecting Link/Rod Holding Screw Snap Ring
25	10627	Connecting Link/Rod Holding Screw Spring Washer
26	17202	Connecting Link/Rod Holding Screw Nut
27	21026	Connecting Rod
28	21027	Skip Stitch Eccentric Shaft
29	21023	Skip Stitch Eccentric Shaft Collar
30	0096006	Skip Stitch Eccentric Shaft Collar Set Screw
31	21028	Skip Stitch Lever Plate
32	0124008	Skip Stitch Lever Plate Set Screw
33	4010	Skip Stitch Lever Plate Ball
34	10052	Skip Stitch Lever Plate Spring
35	S-21029	Skip Stitch Lever
36	0096010	Skip Stitch Lever Set Screw
37	21031	Connecting Link (Short)
38	21032	Connecting Link Holding Pin
39	10060	Connecting Link Holding Pin Snap Ring
40	0094004	Connecting Link Holding Pin Set Screw
41	21033	Connecting Block
42	0214012	Connecting Block Set Screw
43	S-21034	Ridge Forming Disc Shaft Assembly
44	21036	Ridge Forming Disc Shaft Collar
45	0094004	Ridge Forming Disc Shaft Collar Set Screw
46	10517	Ridge Forming Disc Shaft Bushing
47	0094006	Ridge Forming Disc Shaft Bushing Set Screw
48	21069	Cylinder Bed Shaft
49	0096006	Cylinder Bed Shaft Set Screw
50	19117	Cylinder Bed Shaft Snap Ring
51	21070	Cylinder Bed Shaft Spring
52	21071-A	Cylinder Bed Shaft Spring Pin
53	21016	Cylinder Bed Shaft Collar
54	0096006	Cylinder Bed Shaft Collar Set Screw

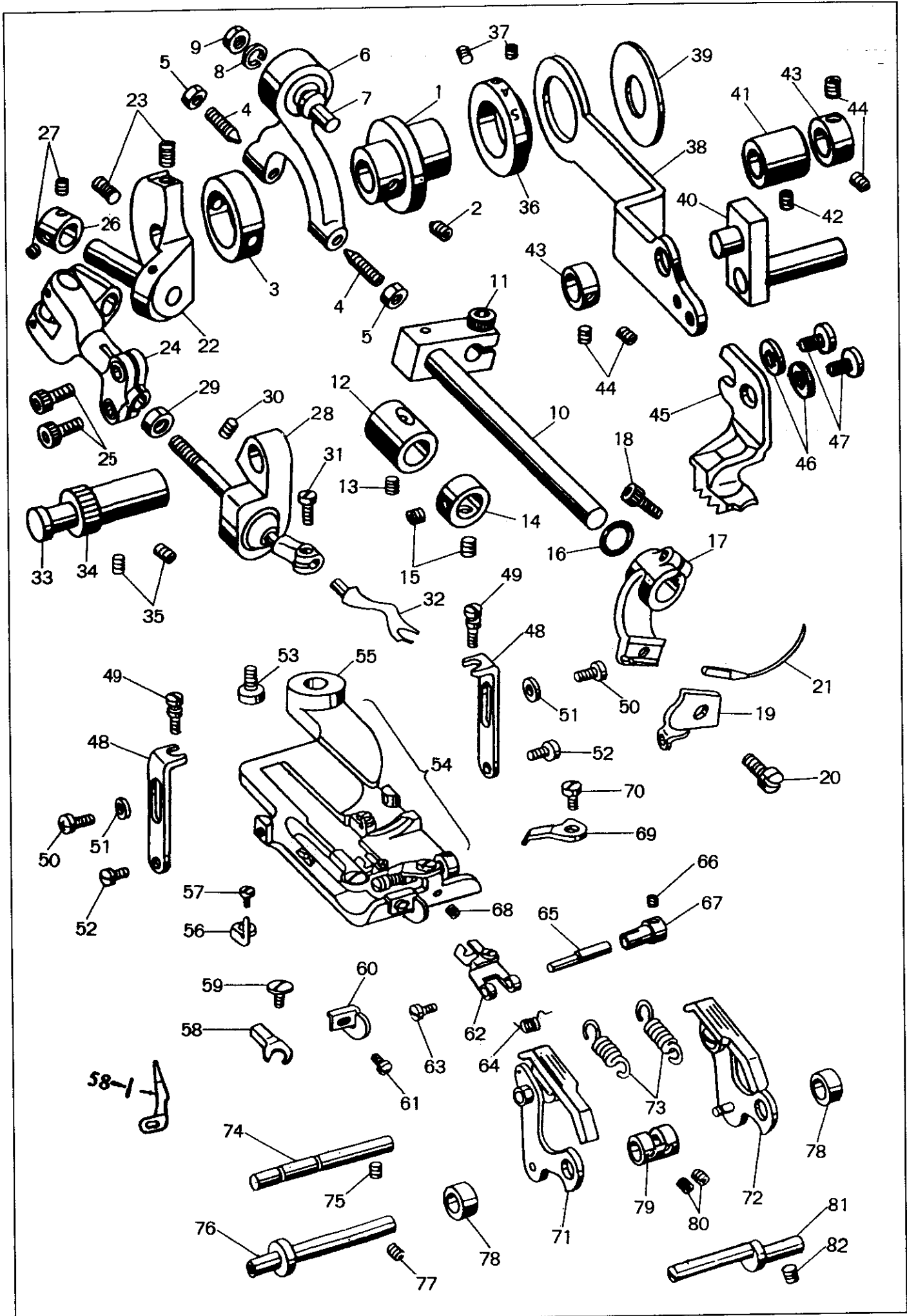

Ref. Nos.	Parts No.	Description	
1	21038	Eccentric Bushing	
2	0085010	Eccentric Bushing Set Screw	
3	21046	Needle Yoke Ring	
4	21047	Needle Yoke Center Screw	
5	21048	Needle Yoke Center Screw Nut	
6	S-21049-A	Needle Yoke & Ball Joint	
7	21052-B	Needle Yoke Eccentric Pin	
8	8179	Needle Yoke Eccentric Pin Spring Washer	
9	C-10022	Needle Yoke Eccentric Pin Nut	
10	S-21053	Needle Carrier Shaft Crank	
11	0214016	Needle Carrier Shaft Crank Set Screw	
12	21055	Needle Carrier Shaft Bushing	
13	0094006	Needle Carrier Shaft Bushing Set Screw	
14	21016	Needle Carrier Shaft Collar	
15	0096006	Needle Carrier Shaft Collar Set Screw	
16	19034	Needle Carrier Shaft "O" Ring	
17	21056	Needle Carrier	
18	0215016	Needle Carrier Clamp Screw	} For Needle System LW x 6T (Re: LW x 5T, refer to page 4.)
19	4025-A	Needle Clamp	
20	121	Needle Clamp Set Screw	
21	4181	Needle (LW x 6T)	
22	S-21057	Looper Drive Crank & Pin	
23	0096014	Looper Drive Crank Set Screw	
24	S-21059	Looper Yoke with Joint & Pin	
25	0214012	Looper Yoke Set Screw	
26	17037	Looper Yoke Pin Collar	
27	17146	Looper Yoke Pin Collar Set Screw	
28	S-21062-A	Looper Carrier Assembly	
29	21048	Looper Carrier Nut	
30	0096006	Looper Ball Joint Clamp Screw	
31	4040	Looper Clamp Screw	
32	4039	Looper	
33	21064	Looper Ball Joint Pin	
34	21065	Looper Ball Joint Eccentric Sleeve	
35	0046008	Looper Ball Joint Eccentric Sleeve Set Screw	
36	21039-A	Stitch Regulating Eccentric	
37	0094006	Stitch Regulating Eccentric Set Screw	
38	21040	Feed Lever	
39	21041	Feed Lever Thrust Washer	
40	S-21042-A	Feed Lever Crank	
41	10517	Feed Lever Crank Bushing	
42	0094006	Feed Lever Crank Bushing Set Screw	
43	21045	Feed Lever Crank Collar	
44	0094004	Feed Lever Crank Collar Set Screw	
45	4047-C	Feed Dog	
46	2528	Feed Dog Washer	
47	4048-A	Feed Dog Set Screw	
48	4061-A	Presser Foot Bracket	
49	21066	Presser Foot Bracket Adjusting Screw	
50	0144008	Presser Foot Bracket Holding Screw	
51	11158	Presser Foot Bracket Holding Screw Washer	
52	4186	Presser Foot Holding Screw	
53	21067	Presser Foot Clamp Screw	
54	PF100	Presser Foot Assembly (Ref. Nos. 54-69)	

Ref. Nos.	Parts No.	Description
55	4049-B	Plain Presser Foot
56	4048-A	Chaining Finger
57	4185	Chaining Finger Set Screw
58	11563	Needle Guide
58-1	11563-A	Stitch Stabilizing Guide
59	4052-A	Needle Guide Set Screw
60	4059	Edge Guide
61	4185	Edge Guide Set Screw
62	4055-CAS	Cloth Retainer
63	4185	Cloth Retainer Screw
64	4056	Cloth Retainer Spring
65	4054	Cloth Retainer Eccentric Stud
66	4183	Cloth Retainer Eccentric Stud Set Screw
67	4053	Cloth Retainer Eccentric Stud Bushing
68	130-B	Cloth Retainer Eccentric Stud Bushing Set Screw
69	4057-B	Cloth Retainer Stopper
70	4182	Cloth Retainer Stopper Set Screw
71	S-21072	Feed Plate Assembly (Left)
72	S-21073	Feed Plate Assembly (Right)
73	21078	Feed Plate Bracket Spring
74	21079	Feed Plate Bracket Spring Pin
75	0094006	Feed Plate Bracket Spring Pin Set Screw
76	21075	Feed Plate Bracket Shaft
77	0094006	Feed Plate Bracket Shaft Set Screw
78	21076	Feed Plate Bracket Shaft Spacer
79	21077	Feed Plate Bracket Shaft Thrust Collar
80	0094004	Feed Plate Bracket Shaft Thrust Collar Set Screw
81	21080	Feed Plate Bracket Eccentric Shaft
82	0094006	Feed Plate Bracket Eccentric Shaft Set Screw

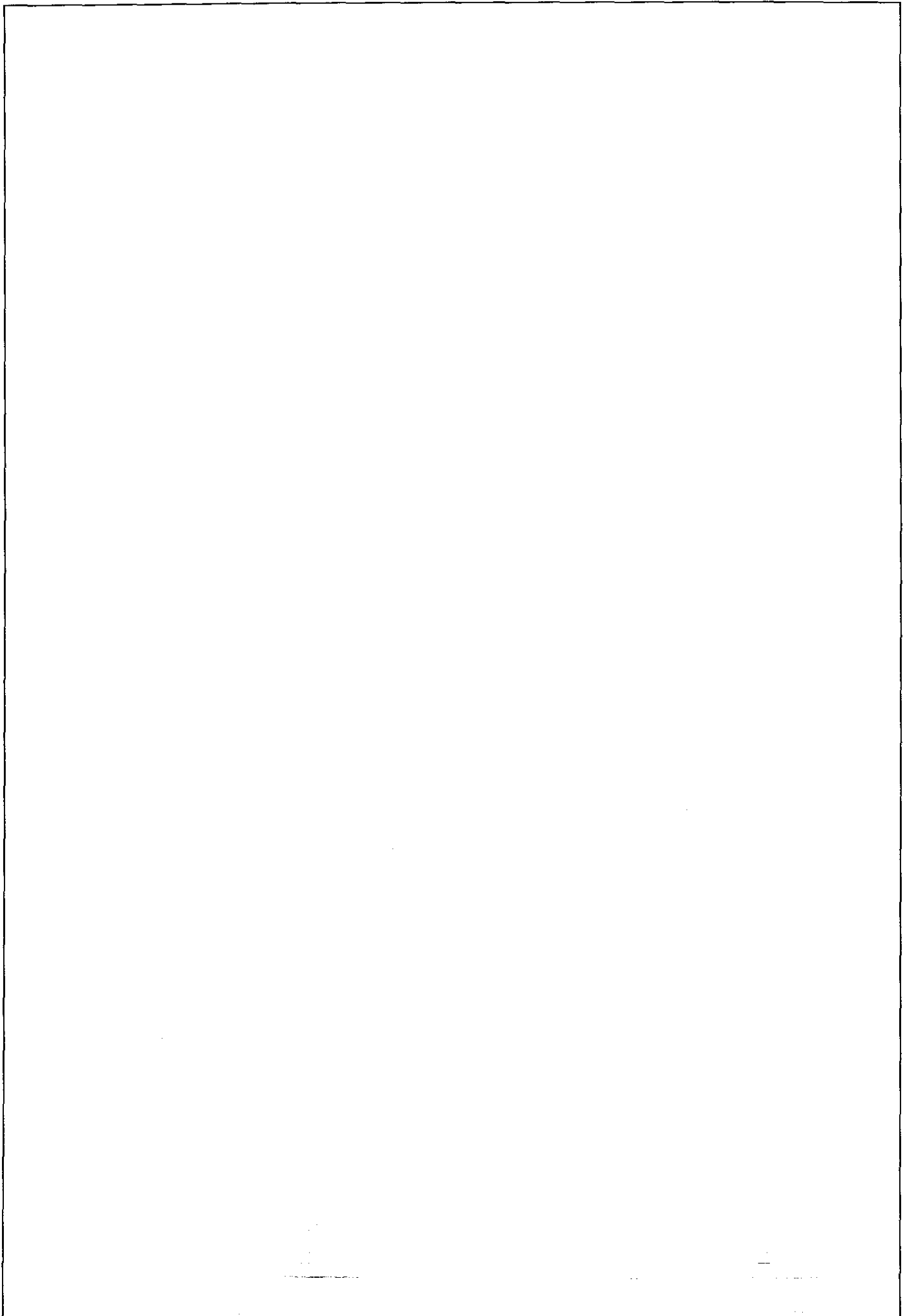

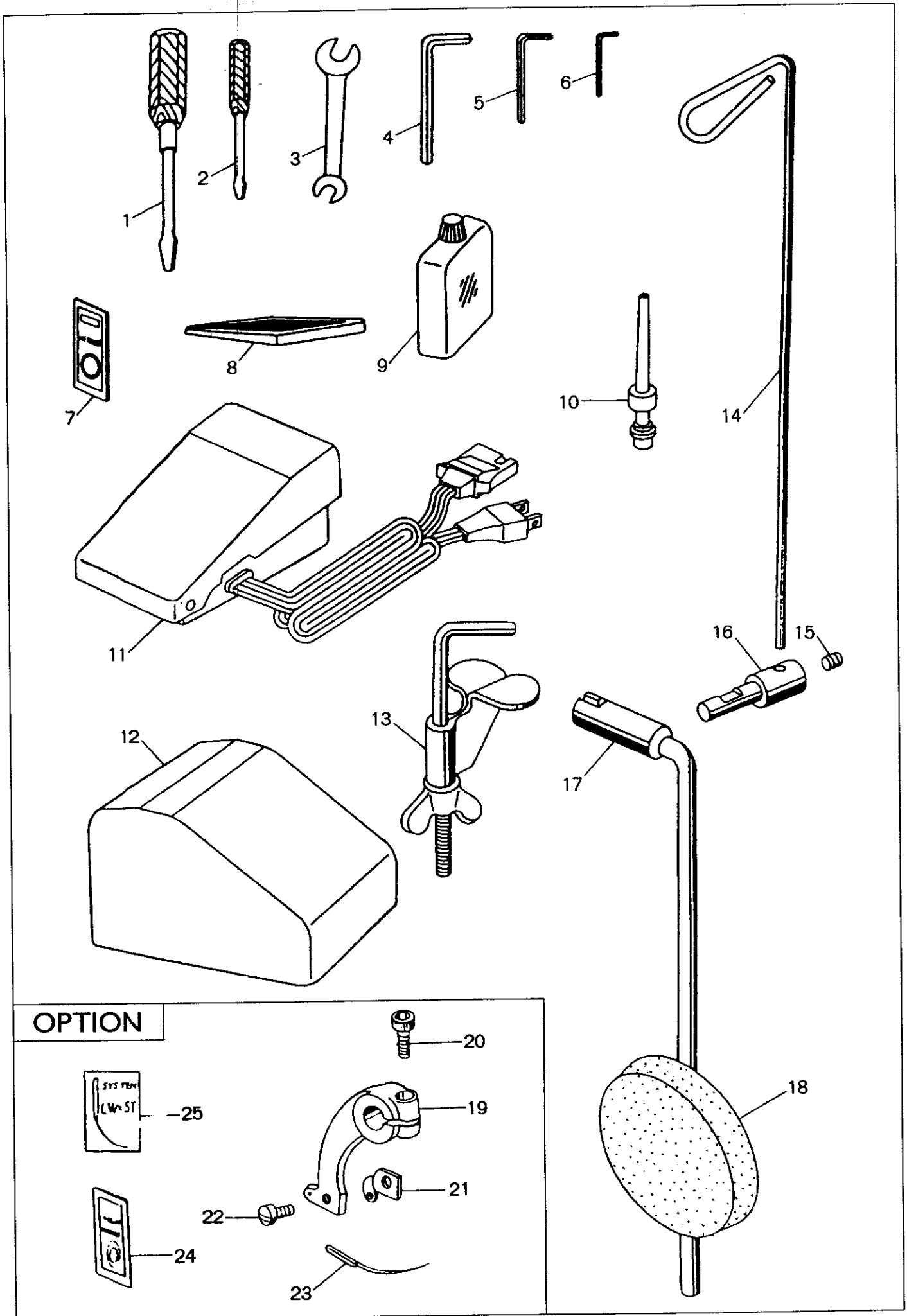

Ref. Nos.	Parts No.	Description
1	AC-02	Screw Driver
2	AC-03	Screw Driver
3	AC-104	Spanner
4	AC-102	Wrench (5m/m)
5	AC-06	Wrench (3m/m)
6	C-16003	Wrench (2m/m)
7	4181	Needle (LW x 6T) (3 pcs)
8	AC-09	Tweezers
9	AC-05A	Oil
10	AC-04A	Oiler
11	10110-A	Controller Pedal
12	C-10A	Vinyl Cover
13	S-21097	Machine Clamp Assembly
14	21103	Thread Guide
15	0044004	Thread Guide Set Screw
16	21092	Thread Guide Stud
17	S-21086	Knee Press Rod & Sleeve
18	S-21088	Knee Press Pad Assembly

OPTIONAL PARTS for Needle System LW x 5T

19	17026	Needle Carrier
20	17144	Needle Carrier Clamp Screw
21	17027	Needle Clamp
22	17145	Needle Clamp Set Screw
23	17028	Needle (LW x 5T)
24	17028	Needle (LW x 5T) (3 pcs)
25	21102	Needle System Lable (LW x 5T)