

GLOBAL

OVERLOCK MACHINE

MODEL: OV 114

INSTRUCTION MANUAL

IMPORTANT SAFETY INSTRUCTIONS

When using an electrical appliance, basic safety precautions should always be followed, including the following:

Read all instructions before using your household sewing machine.

DANGER-To reduce the risk of electric shock:

Your household sewing machine should never be left unattended when plugged in. Always unplug your machine from the electric outlet immediately after using and before cleaning.

Always unplug before relamping. Use a bulb 15 W max.

WARNING-TO reduce: the risk of burns, fire, electric shock, or injury to persons:

-Do not allow to be used as a toy. Close attention is necessary when this sewing machine is used by or near children.

-Use this sewing machine only for its intended use as described in this manual. Use only attachments recommended by the manufacturer as contained in this manual.

-Never operate this sewing machine if it has a damaged cord or plug, if it is not working properly, if it has been dropped or damaged, or dropped into water. Return the sewing machine to the nearest authorized dealer or service center for examination, repair, electrical or mechanical adjustment.

-This machine is equipped with a special cord which, if damaged, must be replaced by an identical cord. This can be obtained from your dealer.

-Never operate the sewing machine with any air openings blocked. Keep ventilation openings of the sewing machine and foot controller free from the accumulation of lint, dust and cloth.

-Never drop or insert any object into any opening.

-Do not use outdoors.

-Do not operate where aerosol (spray) products are being used or where oxygen is being administered.

-Do not put any thing on the control foot release because the machine may accidentally start and the motor or the foot release may overheat.

-To disconnect, turn all controls to the off position, then remove plug from outlet.

-Do not unplug by pulling on cord. To unplug, grasp the plug, not the cord.

-Keep fingers away from all moving parts. Special care is required around the sewing needle.

-Always use the proper needle plate. The wrong plate can cause the needle to break.

-Do not use bent needles

-Do not pull or push fabric while stitching. It may deflect the needle.

-Switch the machine off when making any adjustments in the needle area, such as threading needle, changing needle, or changing presser foot, and the like.

-Always unplug the sewing machine from the electric outlet when making any user servicing mentioned in the instruction manual.

-Use only identical replacement parts.

"SAVE THESE INSTRUCTIONS"

Warning

When working close to the needle, be very careful not to prick your fingers.

When you use the machine for the first time, position a piece of cloth under the presser foot and run the machine without thread for some minutes. Dry any oil spots which might appear.

TABLE OF CONTENTS

1. KNOWING YOUR MACHINE	
Identification chart.....	2
Accessories.....	3
Setting up your machine.....	4
Preparation for threading.....	5-6
Lint tray, Cutting width gauge.....	7
Thread cutter, Changing presser feet.....	7
Changing needle, thread and fabric chart.....	8
2. STARTING TO SEW	
Threading your machine.....	9-12
Helpful hints.....	12
Testing stitch overlock stitches.....	13
Setting chart.....	14
Three-thread overlock with one needle.....	15
Converting to two-thread use.....	15
Narrow and rolled hem, picot stitch.....	16
Adjusting thread tensions.....	17
Adjusting stitch length, Adjusting overedge cutting width, Stitch finger(B).....	18
Differential feed.....	19
Foot pressure regulator.....	20
Sewing with extra heavyweight fabric or multiple layers of fabric.....	20
Basic techniques	
Turning outside corners without cutting threads.....	21
Turning curved edges, Removing stitches from sewn fabric.....	21
Corded overlock.....	22
Decorative effects.....	23
Differential feed applications.....	24
3. CARING FOR YOUR MACHINE	
Replacing moving cutter, Disengaging moving cutter.....	25
Removing face cover.....	25
Cleaning and oiling.....	26
4. CHECKING PERFORMANCE PROBLEMS.....	27

SPECIFICATION OF MACHINE

MODEL	300	320
Number of threads	3 or 4 threads	2, 3 or 4 threads
Overedge stitch width	6mm(left needle) and 3.8mm(right needle)	
Needle	HA1-SP, HA × 1(130/705H)	
Stitch length	1-5mm	
Stitching speed	Up to 1300 stitches per minute	
Dimensions	320 mm(W) × 280mm(P) × 280mm(H)	
Weight	8Kgs (17.6 lbs)	

2. KNOWING YOUR MACHINE

IDENTIFICATION CHART

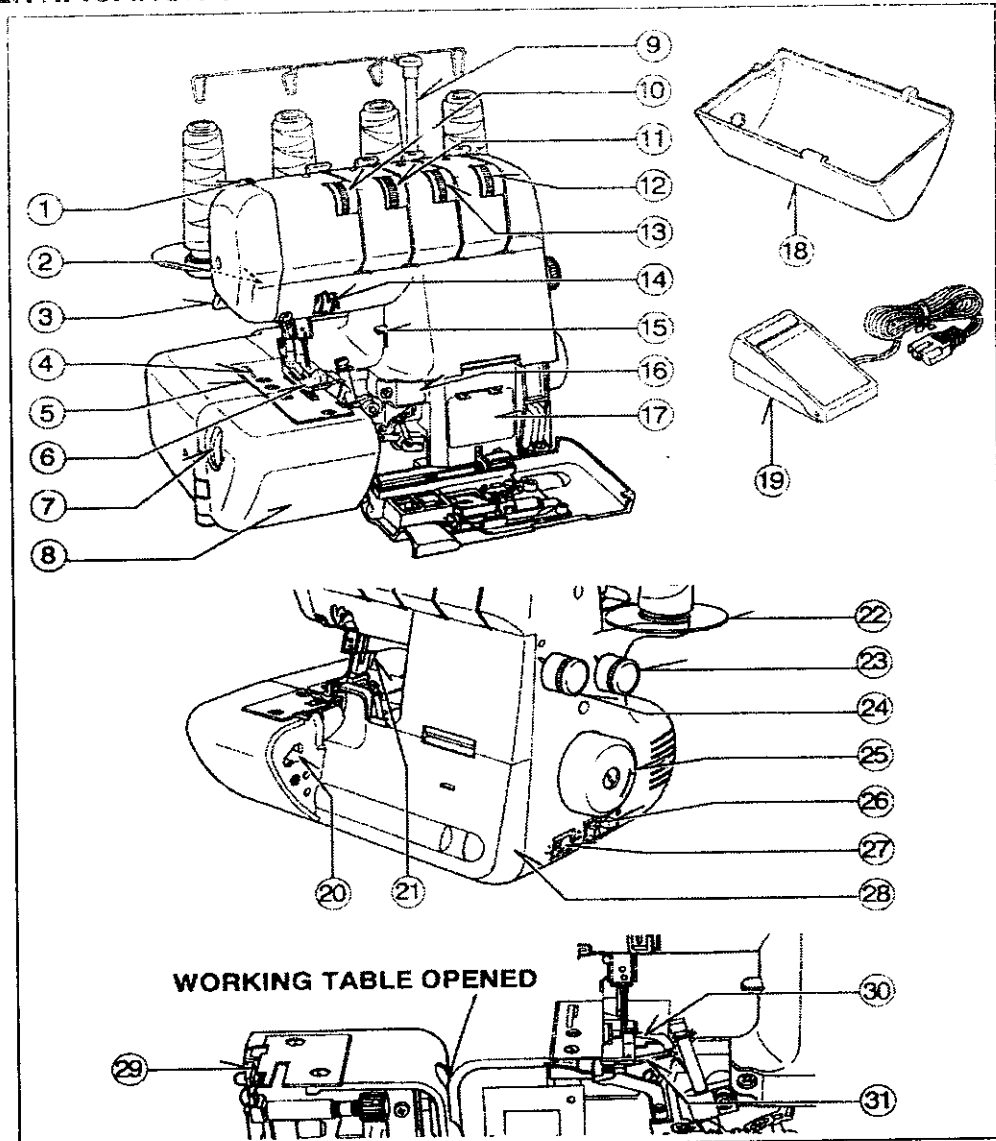

- | | |
|--|--------------------------------------|
| 1. Foot pressure regulator | 16. Two thread convertor instruction |
| 2. Sewing light | 17. Threading chart |
| 3. Presser foot lever | 18. Lint tray |
| 4. Thread cutter | 19. Foot control |
| 5. Needle plate | 20. Release lever |
| 6. Presser foot | 21. Foot release lever |
| 7. Overedge cutting width dial | 22. Spool disc |
| 8. Working table | 23. Differential feed control dial |
| 9. Thread guide pole | 24. Stitch length dial |
| 10. Left needle thread tension control | 25. Hand wheel |
| 11. Right needle thread tension control | 26. Plug connector socket |
| 12. Lower Loooper thread tension control | 27. Light and power switch |
| 13. Upper looper thread tension control | 28. Front cover |
| 14. Needle thread guides | 29. Moving cutter |
| 15. Thread cutter lever | 30. Upper looper |
| | 31. Lower looper |

ACCESSORIES

All parts listed may be obtained from your nearest dealer.

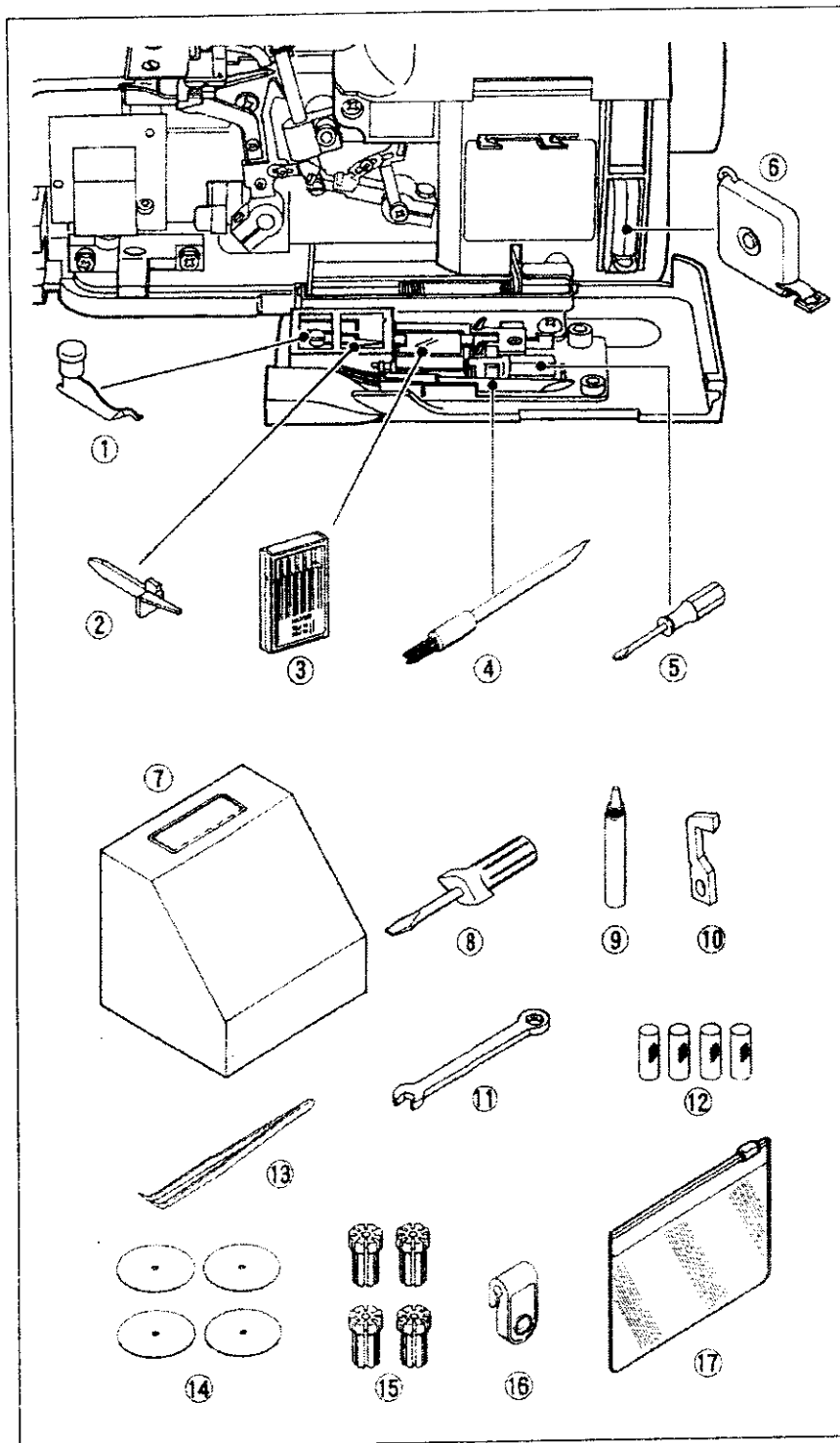

1. Two-thread convertor
2. Stitch finger (B)
3. Needle set(option)
4. Brush(option)
5. Screwdriver (small)
6. Tape measure (option)
7. Machine cover
8. Screwdriver (large)
9. Oiler
10. Moving cutter
11. Spanner
12. Thread net
13. Tweezers
14. Spool disc
15. Spool holder
16. Cord guide
17. Accessory bag

* Only Model 320 has storage of accessories at the back of front cover.

SETTING UP YOUR MACHINE

1. Wipe off excess oil in the needle plate and bed areas.

2. **FOOT CONTROL**

Push foot control plug into connector socket, and connect the power line plug into power supply outlet.

3. **POWER/LIGHT SWITCH**

Your machine will not operate unless the power/light switch is turned on. This same switch controls both machine power and sewing light.

When leaving the machine unattended, or servicing the machine, remove the power line plug from supply outlet..

4. **OPENING FRONT COVER**

To open front cover, pull it to the right and down towards you.

5. **OPENING WORKING TABLE**

To open working table, pull the release lever towards you with your right hand, and lift the front of presser foot up with your left hand.

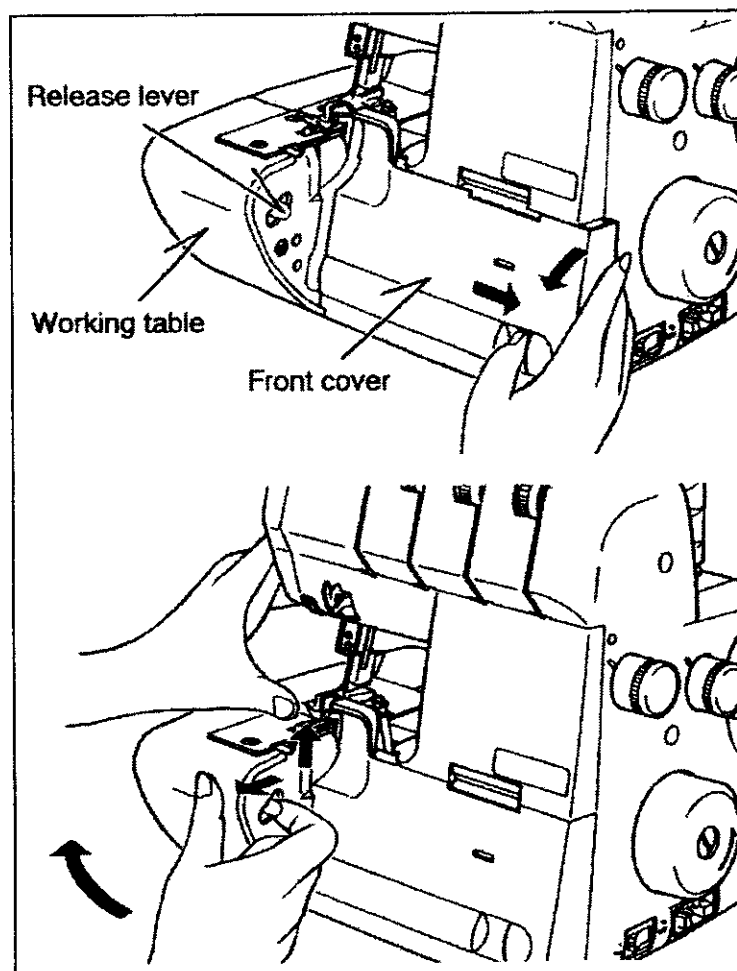
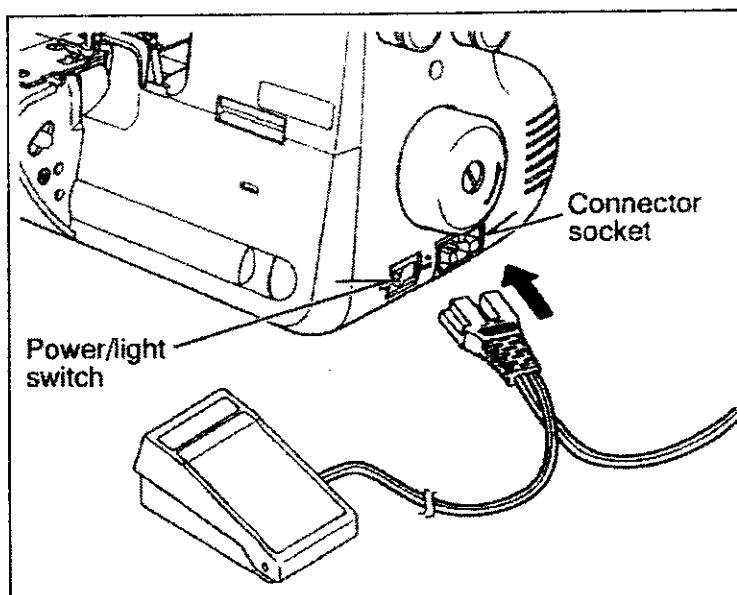

PREPARATION FOR THREADING

THREAD GUIDE POLE

Pull up thread guide pole to the highest point until you hear it click. Place thread spools on pins and draw thread through thread guides on the pole from rear to front.

Thread guide of pole can hold thread spools on the spool stand by pulling down the pole as illustrated.

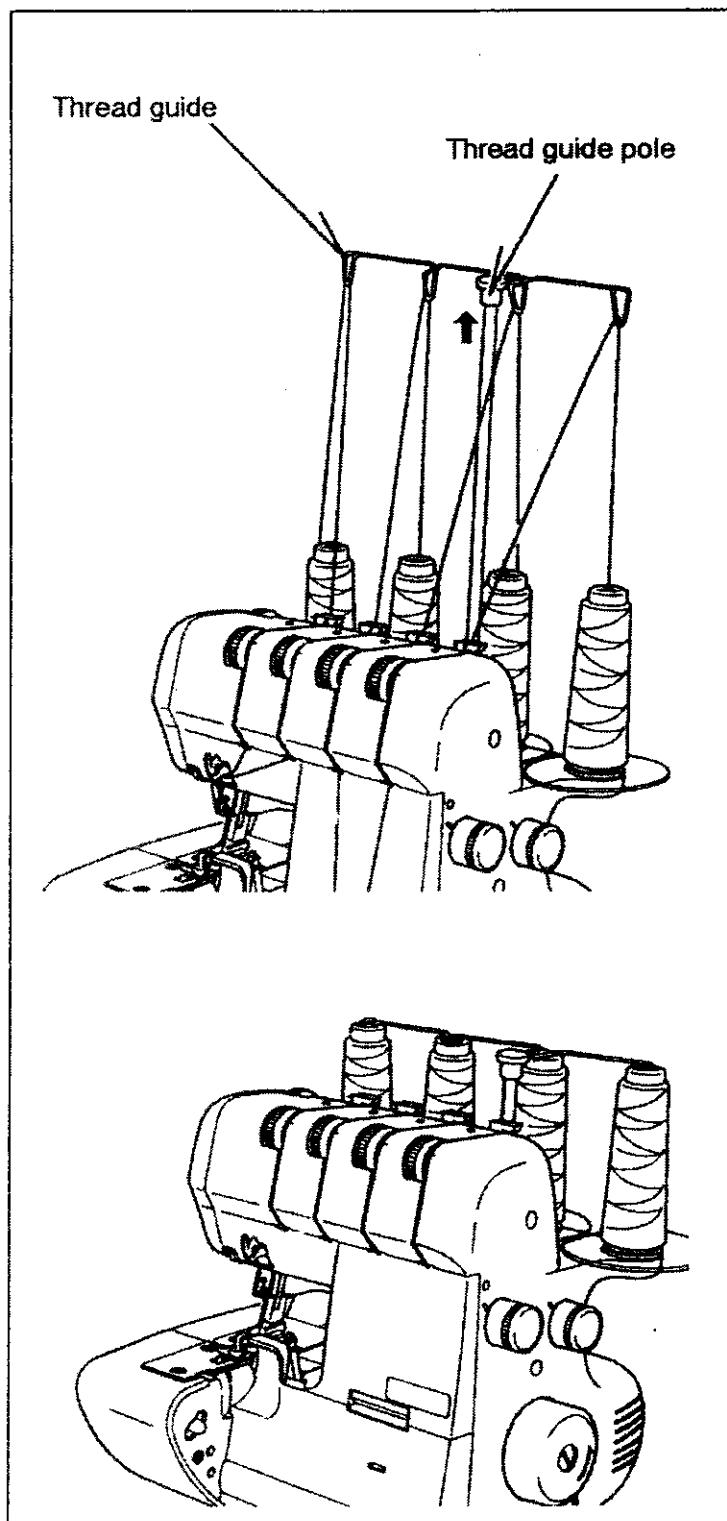

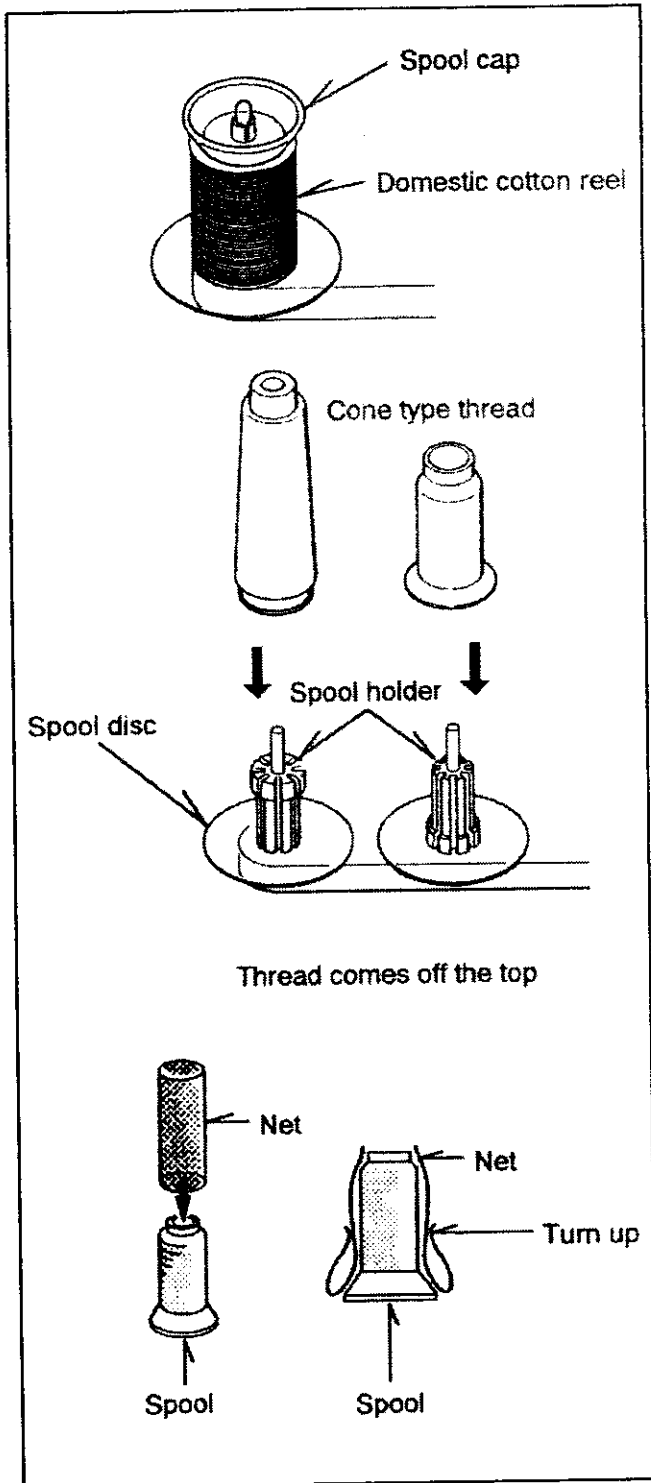

SPOOL CAPS FOR DOMESTIC TYPE SPOOLS

SPOOL DISC AND SPOOL HOLDERS FOR CONE SPOOLS

For large cone spools use the rubber spool holders with the wide end at the top, and for small ones, use the same rubber spool holders but with the narrow end at the top.

SPOOL NETS

Polyester or bulky nylon threads become loose while unwinding. To keep consistent feeding of such threads, utilize spool net sleeving over the spool.

LINT TRAY

With the lint tray located in this position, it will collect all your waste material.

After completion of work if you then turn tray upwards in direction shown, finger Ref C will locate in slot D and left hand pin will slide into lower hole B.

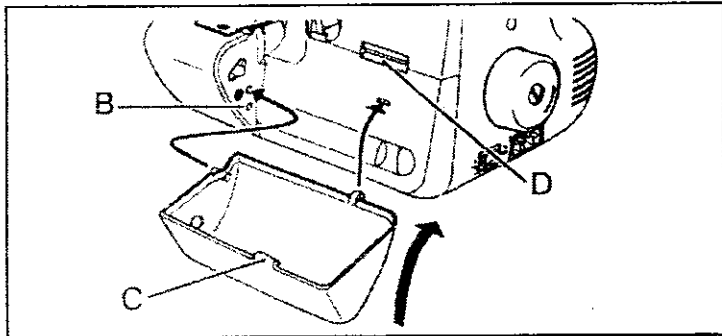

CUTTING WIDTH GAUGE

When using cutting width gauge, the fabric is cut down and sewn at same distance from the edge of fabric.

Within the distance of the width adjusted.

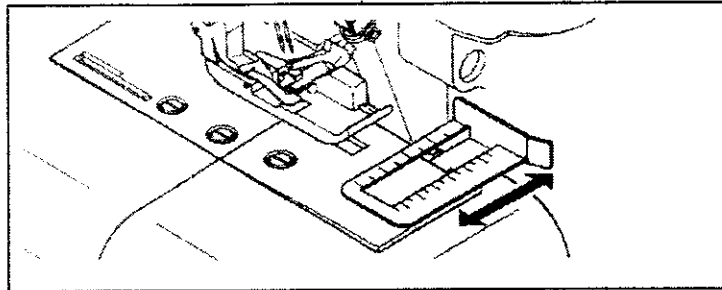

THREAD CUTTER

Thread cutter is built in needle plate. Make sure that power switch is off, then trim thread near the end of fabric by pushing down lever as illustrated.

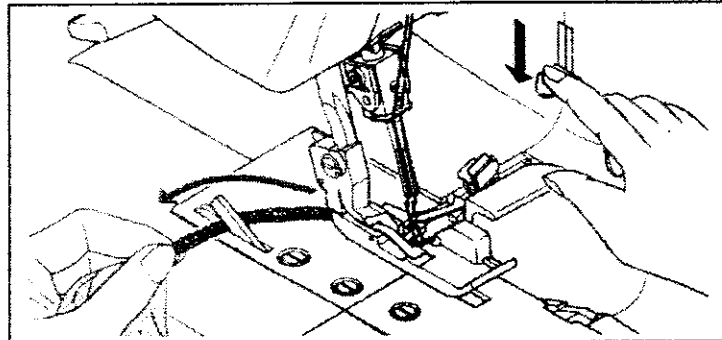

CHANGING PRESSER FEET

Be sure needle is in the up position. Raise presser foot lever.

1. Push foot release lever to remove the foot.
2. Place the desired foot on the needle plate aligning needle holes.
3. Lower the presser foot lever and push foot release lever so that the foot holder snaps on the foot.

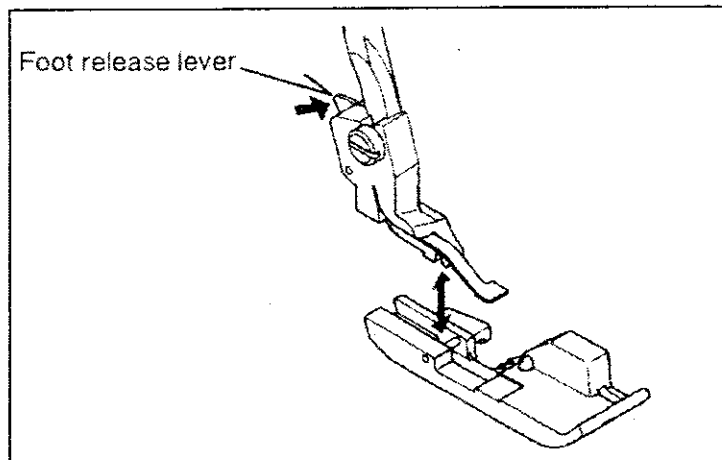

CHANGING NEEDLE

Raise needle bar to its highest point by turning hand wheel towards you, but leave presser foot down. Loosen needle clamp screw to remove the needle, and place new needle with Flat Side Away From you, into the needle bar as far as it will go, and tighten screw.

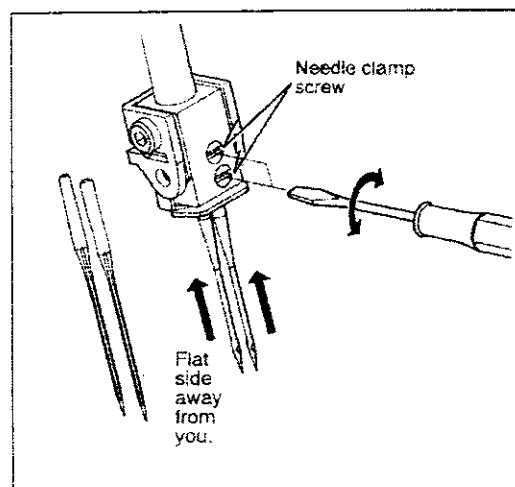

NEEDLE, THREAD AND FABRIC CHART

Use HA ×1 SP, HA ×1 (130/705H) Needles.

FABRIC		THREAD	NEEDLE
COTTON LINEN	Light weight: Organdy, Lawn, Gingham	Cotton No.100	90(14) for general sewing 75(11) for light weight fabrics
	Heavy weight: Oxford, Denim, Cotton Gabardine	Polyester No.60-50 Cotton No.60	
WOOL	Light weight: Tropical, Wool, Poplin	Polyester No.80 Cotton No.60	
	Serge, Gabardine, Flannel	Polyester No.80-60 Cotton No.60	
	Heavy weight: Velours, Camelhair, Astrakhan	Polyester No.60-50 Cotton No.60	
SYNTHETIC FIBRE	Light weight: Georgette Crape, Voile, Satin	Polyester No.100-80 Cotton No.120-80	
	Heavy weight: Taffeta, Twills, Denim	Polyester No.60 Cotton No.60	
KNIT	Tricot	Polyester No.80-60 CottonNo.80-60	
	Jersey	Polyester No.60-50 Cotton No.60	
	Wool	Polyester No.60-50 Bulk Nylon	

*Synthetic threads are recommended for ordinary overlocking. Polyester thread, for example, is very useful for different types of fabric.

NOTE: Keep in mind that the lower and upper loopers will use about twice the amount of thread as the needles. When purchasing thread for sewing, therefore, especially if it is an unusual colour, you should buy sufficient for your requirements.

2. STARTING TO SEW

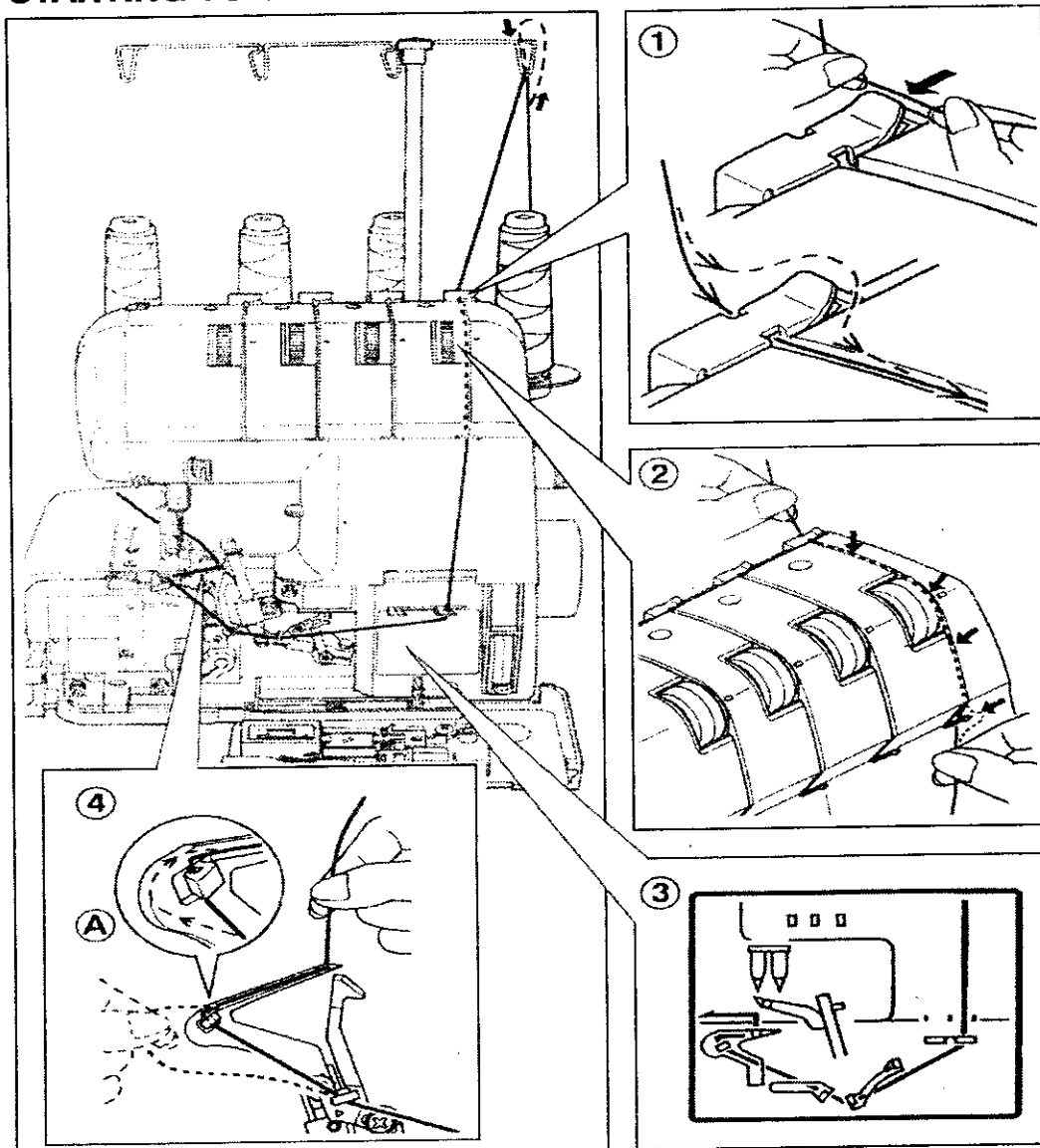

THREADING YOUR MACHINE

Wrong threading may cause skipped stitches, breaking threads, or other problems.

Try to master the correct threading before moving on to test sewing.

Threading must be carried out in the sequence of Lower Loper – Upper Loper – Needle.

Open the front cover and the working table.

Raise needle to its highest point by turning hand wheel towards you, and raise the presser foot.

Before re-threading lower looper, remove thread from needle eye first, then re-thread the lower looper. This will prevent tangling.

NOTE: Thread tension is released when the presser foot is lifted up.

THREADING LOWER LOOPER

1. Feed the thread through the thread guide as illustrated.
2. Pull the lower thread through tension slot. Holding the thread with your left hand, pull down with right hand firmly.
3. Draw the thread through thread guide as illustrated.
4. Pass the thread through lower looper eye, and hook it around part A as indicated by the arrow. Leave about 4" (10cm) extra thread.

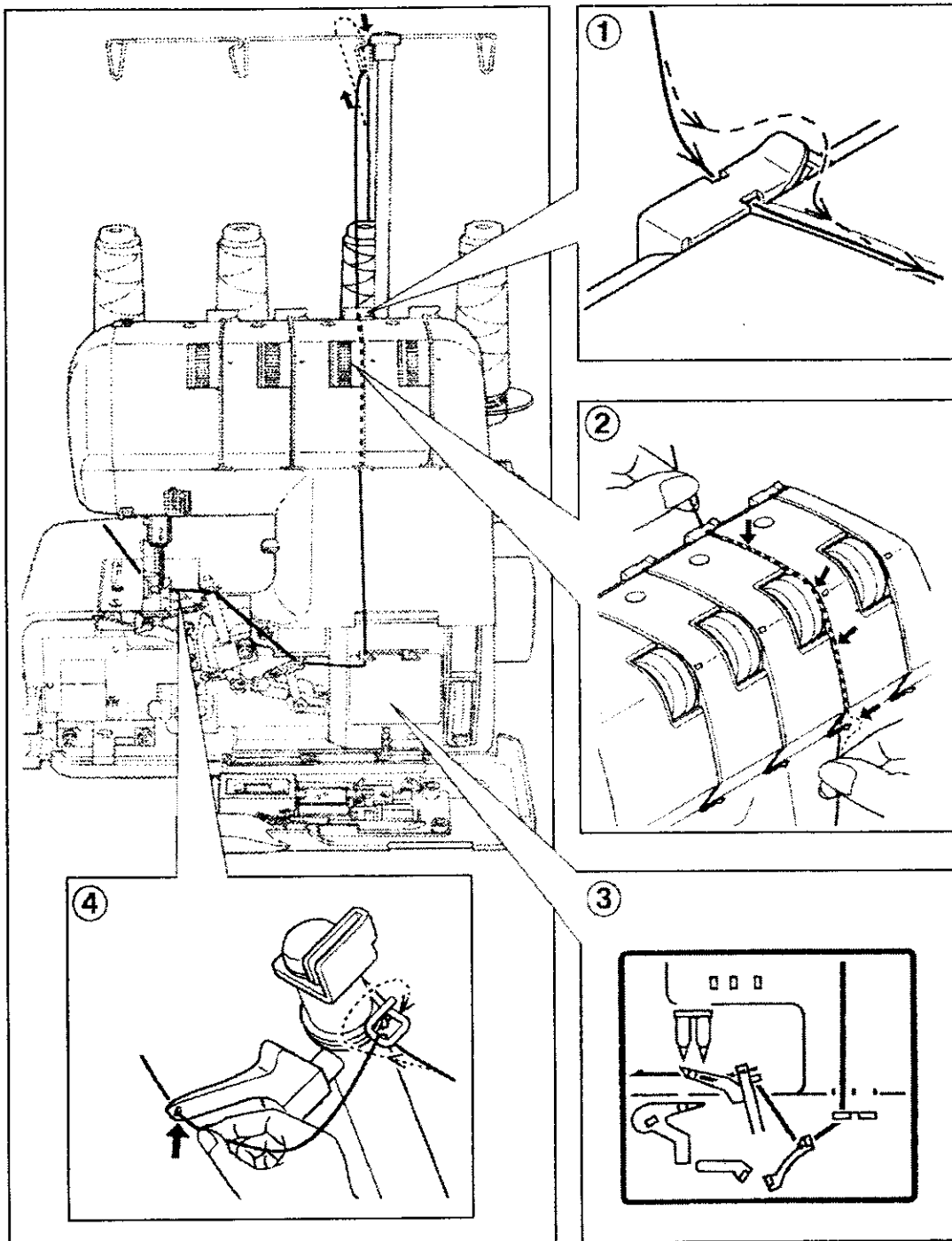

THREADING UPPER LOOPER

1. Feed the thread through the thread guide as illustrated.
2. Pull the upper thread through the slot, holding the thread with your left hand.
3. Draw the thread through the thread guide as illustrated.
4. Pass the thread through wire thread guide and looper eye, leaving an excess length of about 4"(10 cm)

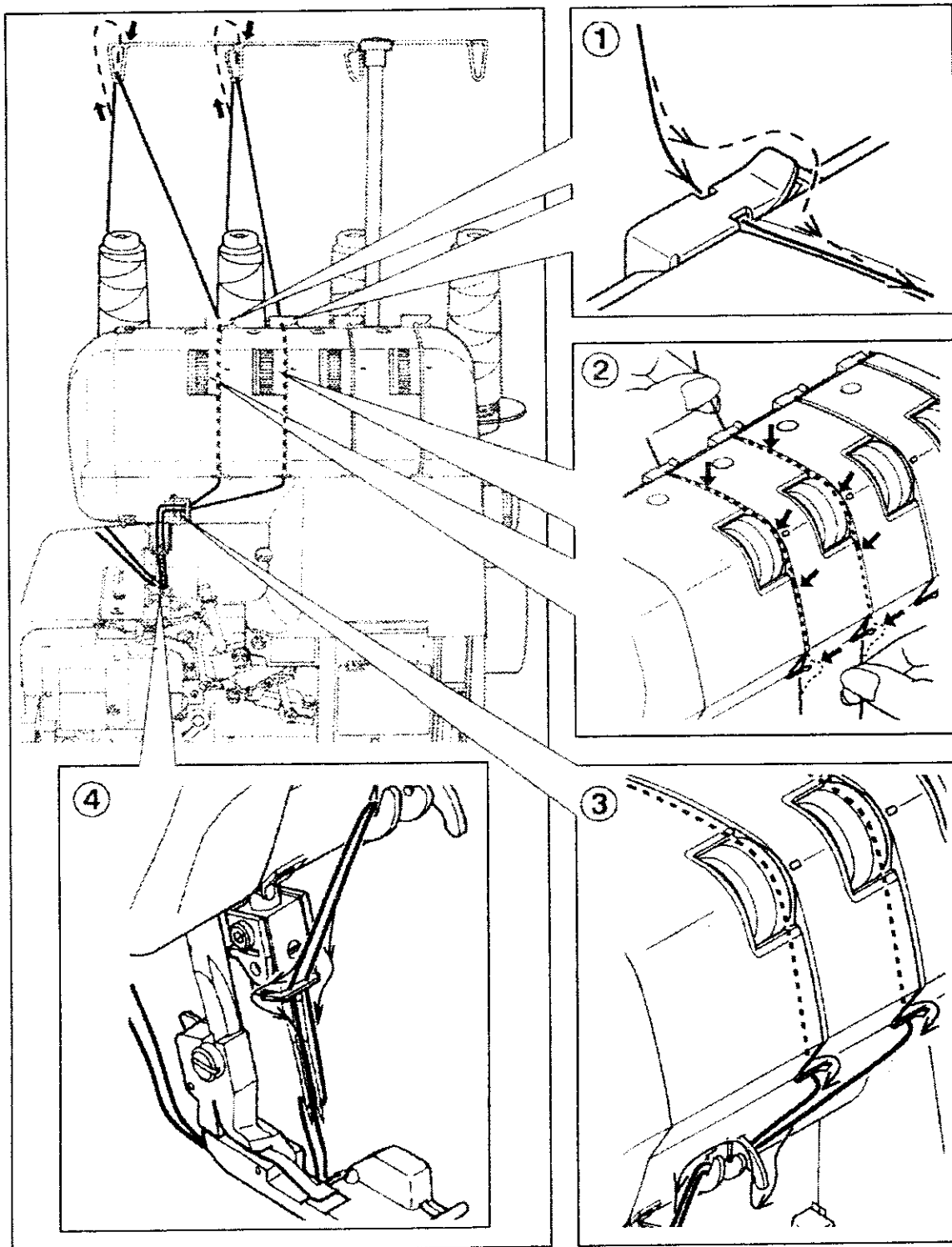

THREADING NEEDLES

1. Feed the thread through the thread guide as illustrated.
2. Draw the needle threads through left-hand tension slot. Holding the thread with your left hand, pull down with right hand firmly.
3. Draw the thread through the thread guide as illustrated.
4. Thread the needles from front to back through needle eye and pull the threads towards the back passing along the right side of presser foot, leaving an extra length of about 4" (10cm)

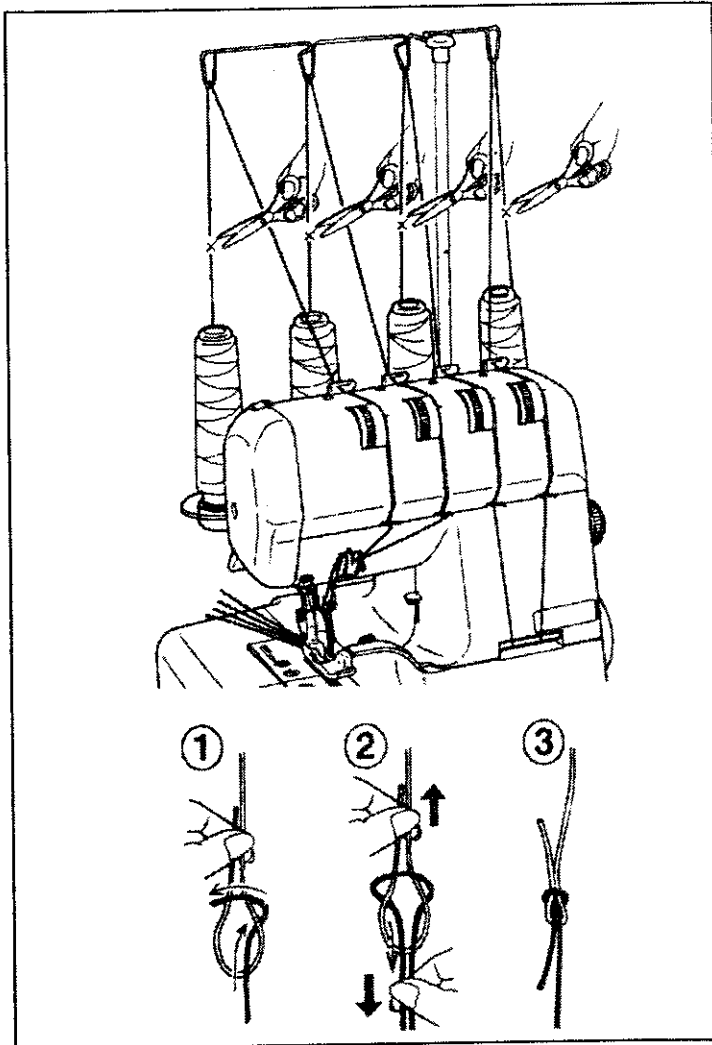

HELPFUL HINTS

REPLACING THREAD SPOOLS

When replacing thread spools, the following steps may be helpful for quick changeover.

1. Cut off existing threads near the spools. Tie the cut ends thread from new spools as illustrated (seamen's knot).
2. Raise presser foot.
3. Lower needle bar to its lowest position by turning hand wheel away from you. Carefully pull the existing threads until the connecting knots pass through needle eye and looper eyes.

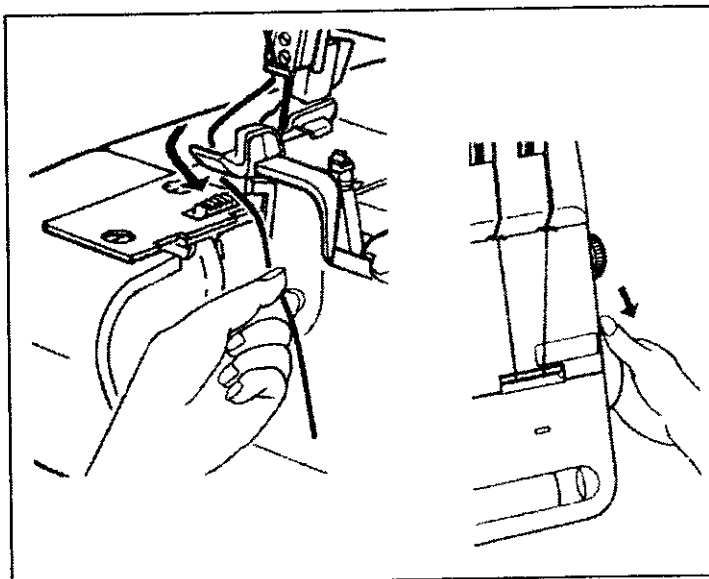

CUTTING NEEDLE THREAD

Frayed thread may make needle threading difficult.

Draw the thread near the thread cutter on the needle plate and push the thread cutter lever or draw the thread passing under the moving cutter and turn hand wheel towards you to obtain clear cut end as illustrated.

TESTING STITCH OVERLOCK STITCHES

After threading is completed, use a scrap of fabric that you plan to sew and test to sew in the following order.

1. Gently pulling all the threads to the left, lower the presser foot. Rotate the hand wheel towards you a few times to see if the lock stitches are properly formed.
2. Start the machine at low speed and feed in test fabric under the presser foot by slightly pushing it forward. (This can be done with the presser foot down on most fabrics except bulky materials.) Guide the fabric gently as machine automatically feeds the material.
3. Check thread tensions by test sewing on spare fabric. (See page 17.)
4. At fabric end, carry on running machine at low speed, gently pulling the fabric towards the back, until about 5 to 6 cm of extra lock stitches are produced without fabric.
5. Cut thread by pushing thread cutter lever down, or with scissors.

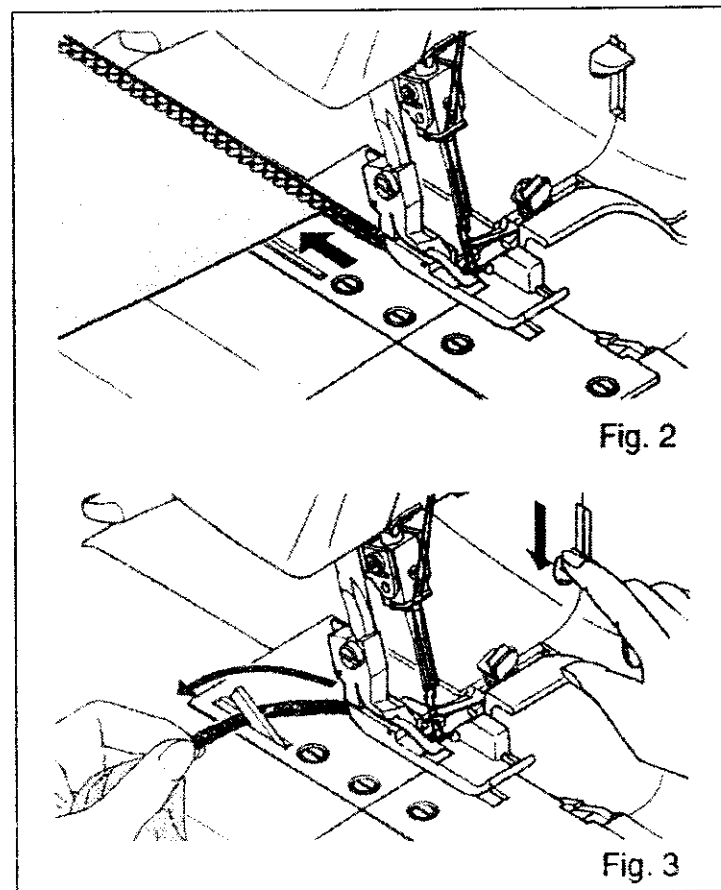
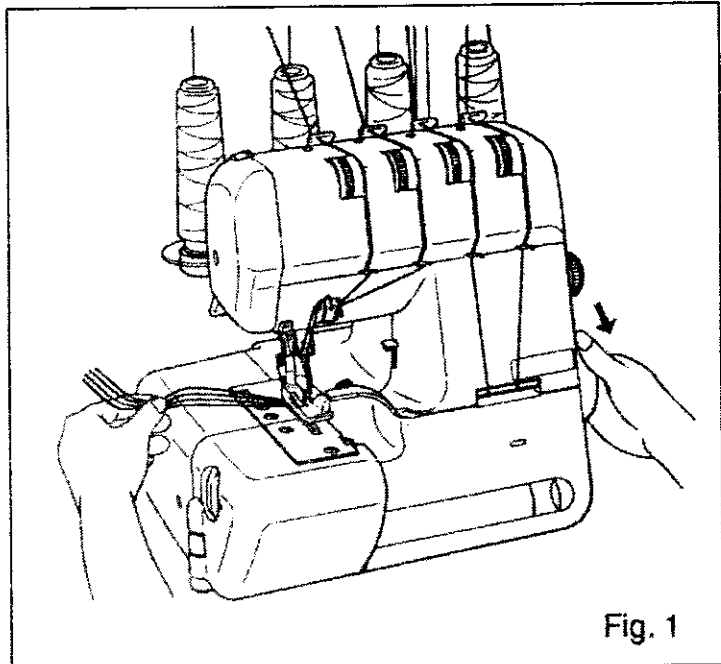

SETTING CHART

Number of thread	3						2	
	4		6		4-6		6	
Overedge cutting width dial	-6		4		-5		4-6	
Needle to use	Left&Right		Right		Left		Right	
Stitch finger	O		O		O		O	
Two thread convertor								
Tension control	Left needle thread		-4		-4		-4	
	Right needle thread		-4		-4		-4	
	Upper looper thread		-4		-4		-4	
	Lower looper thread		-4		-4		-4	
Stitch length control	2.5-3.5		3-5		2-2.5		*R- *P- 2.5-3.5	
Ref. NO.	①		② ③ ④ ⑤		⑥ ⑦ ⑧ ⑨ ⑩		⑪ ⑫	
Image								
Image								
Image								
Image								
Image								
Image								
Image								
Image								
Image								
Image								
Image								
Image								
Image								
Image								
Image								
Image								
Image								
Image								
Image								
Image								
Image								
Image								
Image								
Image								
Image								
Image								
Image								
Image								
Image								
Image								
Image								
Image								
Image								
Image								
Image								
Image								
Image								
Image								
Image								
Image								
Image								
Image								
Image								
Image								
Image								
Image								
Image								
Image								
Image								
Image								
Image								
Image								
Image								
Image								
Image								
Image								
Image								
Image								
Image								
Image								
Image								
Image								
Image								
Image								
Image								
Image								
Image								
Image								
Image								
Image								
Image								
Image								
Image								
Image								
Image								
Image								
Image								
Image								
Image								
Image								
Image								
Image								
Image								
Image								
Image								
Image								
Image								
Image								
Image								
Image								
Image								
Image								
Image								
Image								
Image								
Image								
Image								
Image								
Image								
Image								
Image								
Image								
Image								
Image								
Image								
Image								
Image								
Image								
Image								
Image								
Image								
Image								
Image								
Image								
Image								
Image								
Image								
Image								
Image								
Image								

THREE-THREAD OVERLOCK WITH ONE NEEDLE

By threading the LEFT needle only a width of 6 mm will be produced and by threading the RIGHT needle only a width of 3.8 mm will be produced.

Please keep the unused needles on the needle pad as illustrated.

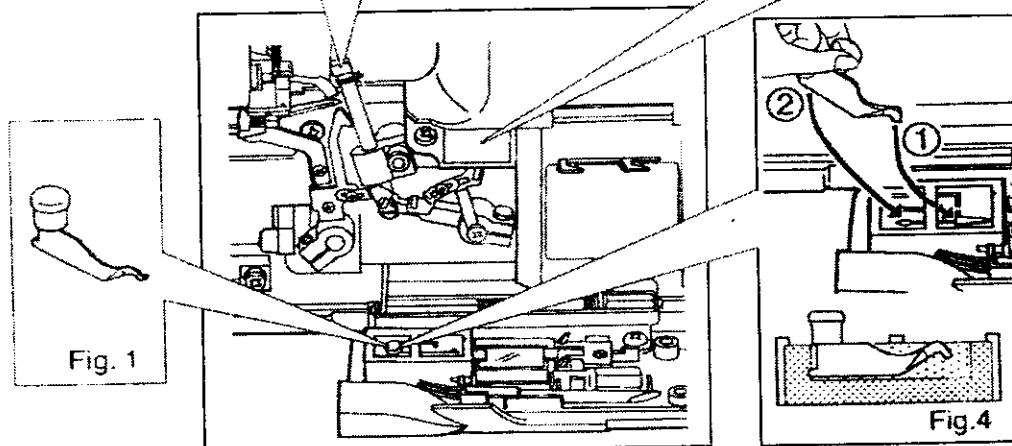
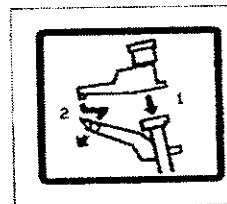
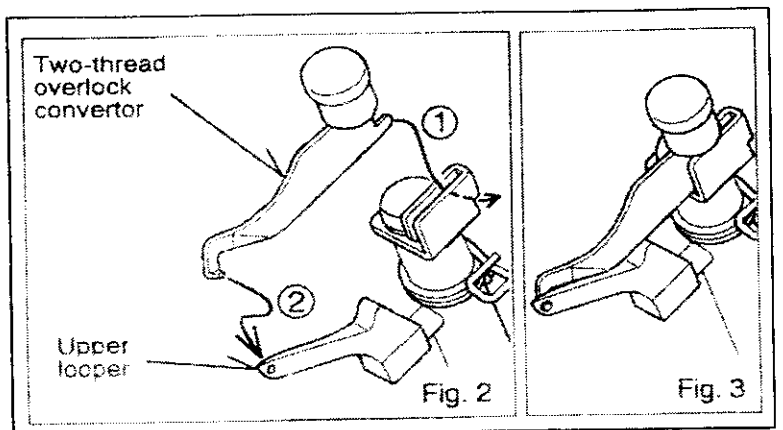
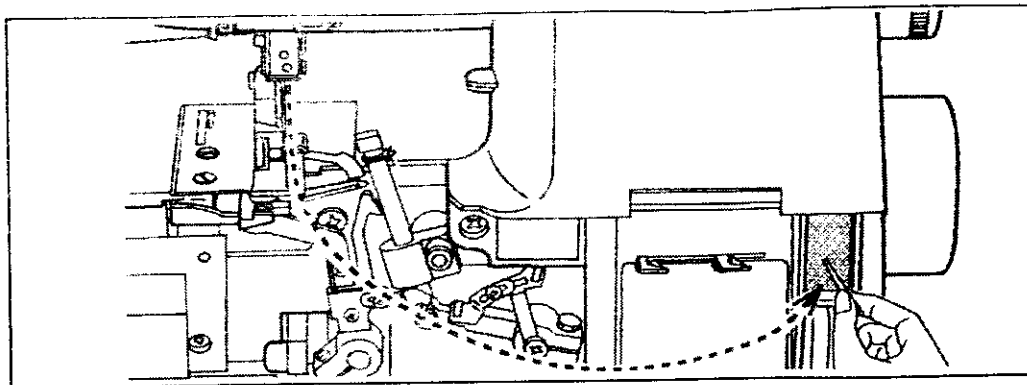

CONVERTING TO TWO-THREAD USE

To convert to two thread use, first open the front cover and working table and raise needle to its highest point by turning hand wheel towards you. Remove the right needle and use the left needle. Please keep the unused needle on the needle pad.

Pull out the convertor as shown in Fig.1.

Attach the two-thread convertor onto the upper looper as shown in Fig. 2, Fig.3.

When not using convertor, insert it deep and keep as illustrated in Fig.4.

NARROW AND ROLLED HEM, PICOT STITCH

Narrow and rolled edge is ideal for use on thin materials such as georgette crepe, crepe de chine, silk etc.

Also, picot stitch can be produced particularly when sewing on fine 'scarflike' materials.

In view of the nature of these hems, they are unsuitable for use on 'hard' or 'heavy' materials.

1. Raise the presser foot.
2. Open the front cover and working table.
3. Remove the stitch finger from the needle plate by screw driver and keep it in the front cover as illustrated or in the accessory bag.
4. Set the machine according to page 14.

NOTE: 1. Please use following recommended thread for making ideal seams.

2. After finishing, reset the stitch finger in its place. Please ensure inserting it deep as illustrated in Fig 1.

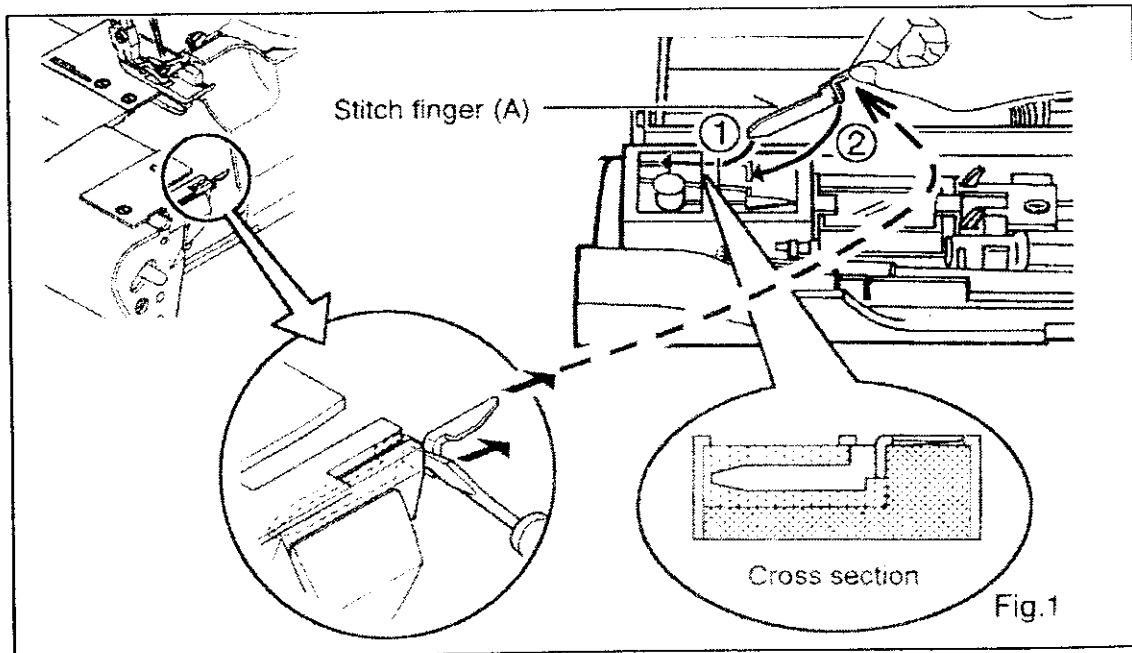

RECOMMENDED THREAD

	Narrow overlock edge	Rolled edge	
	With Three Threads	With Three Threads	With Two Threads
Thread for needle	Polyester, Nylon, Silk No.50-100	Nylon No.100	
Upper looper	Polyester, Nylon, Silk No.50-100	-----	
Lower looper	Bulk nylon (less stretchable)	Bulk nylon (less stretchable)	

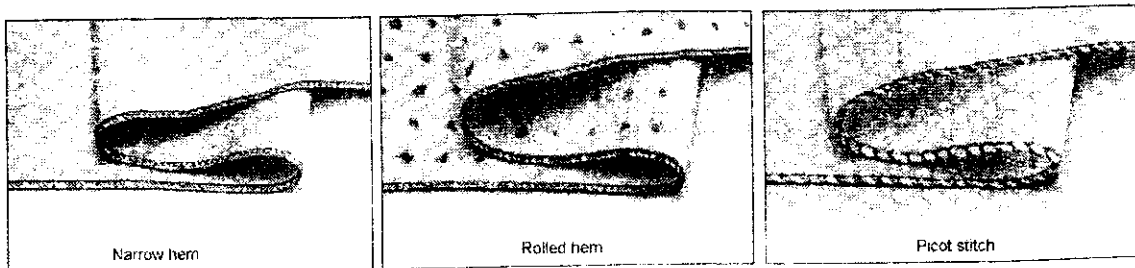

ADJUSTING THREAD TENSIONS

Turning tension dial to a higher number gives a tighter thread tension. Turning tension dial to a lower number gives a looser thread tension. The higher the number, the tighter the tension.

Test each thread tension on a scrap of the fabric you plan to use.

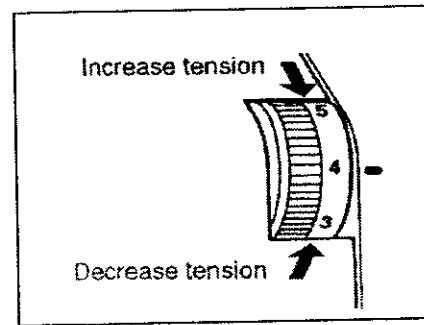

TWO-THREAD USE

Just right

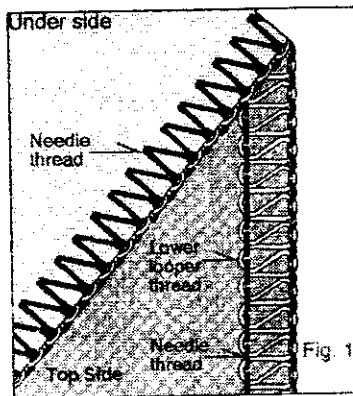

Lower looper thread pulled to under side

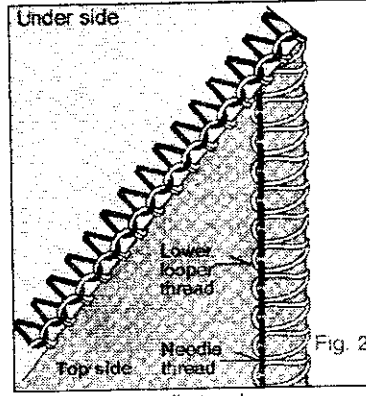

Decrease needle tension

Needle thread Pulled to top side

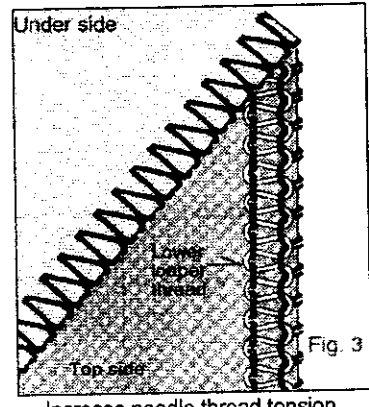

Increase needle thread tension

FOUR-THREAD USE

Just right

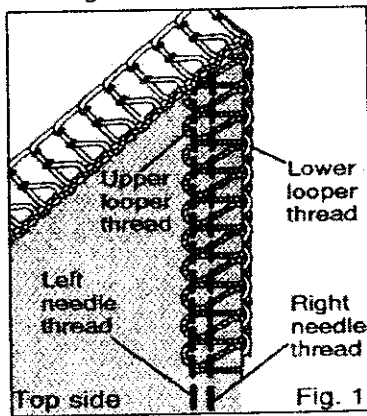

Upper looper thread pulled to top side

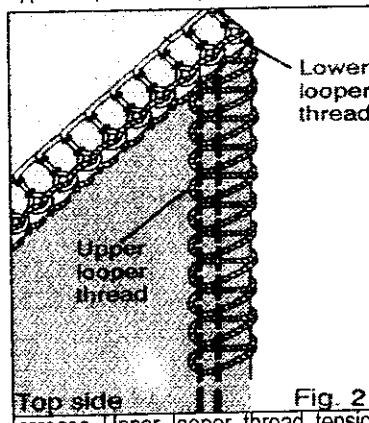

Increase Upper looper thread tension and/or decrease lower looper tension

Lower looper thread pulled to top side

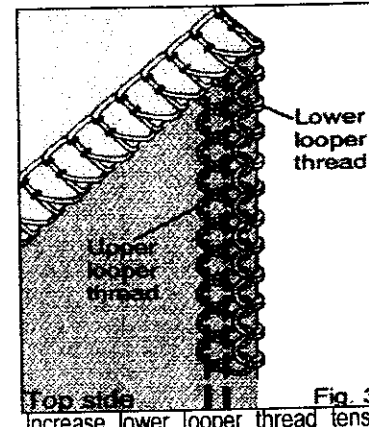

Increase lower looper thread tension and/or decrease upper looper tension

Left needle thread loose and visible on under side of fabric.

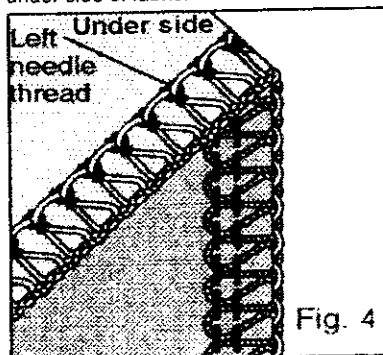

Increase left needle thread tension and/or decrease either or both looper threads.

Right needle thread loose and visible on under side of fabric.

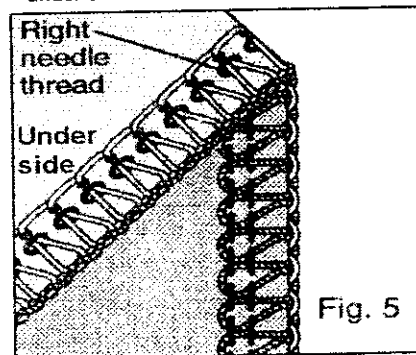

Increase right needle thread tension.

ADJUSTING STITCH LENGTH

Turn the stitch length dial until the required length is indicated.

The higher the number, the longer the stitch. This dial can adjust the stitch length from 1 to 5 mm.

ADJUSTING OVEREDGE CUTTING WIDTH

Overedge cutting width can be adjusted from 4 to 7 mm by simply turning overedge cutting width dial according to the kind of fabric.

It is set at standard width of 6 mm when delivered from the factory.

Turn it towards "5" if fabric edge curls while sewing.(Fig.1)

Turn it toward "7" if loops hang off the edge. (Fig.2)

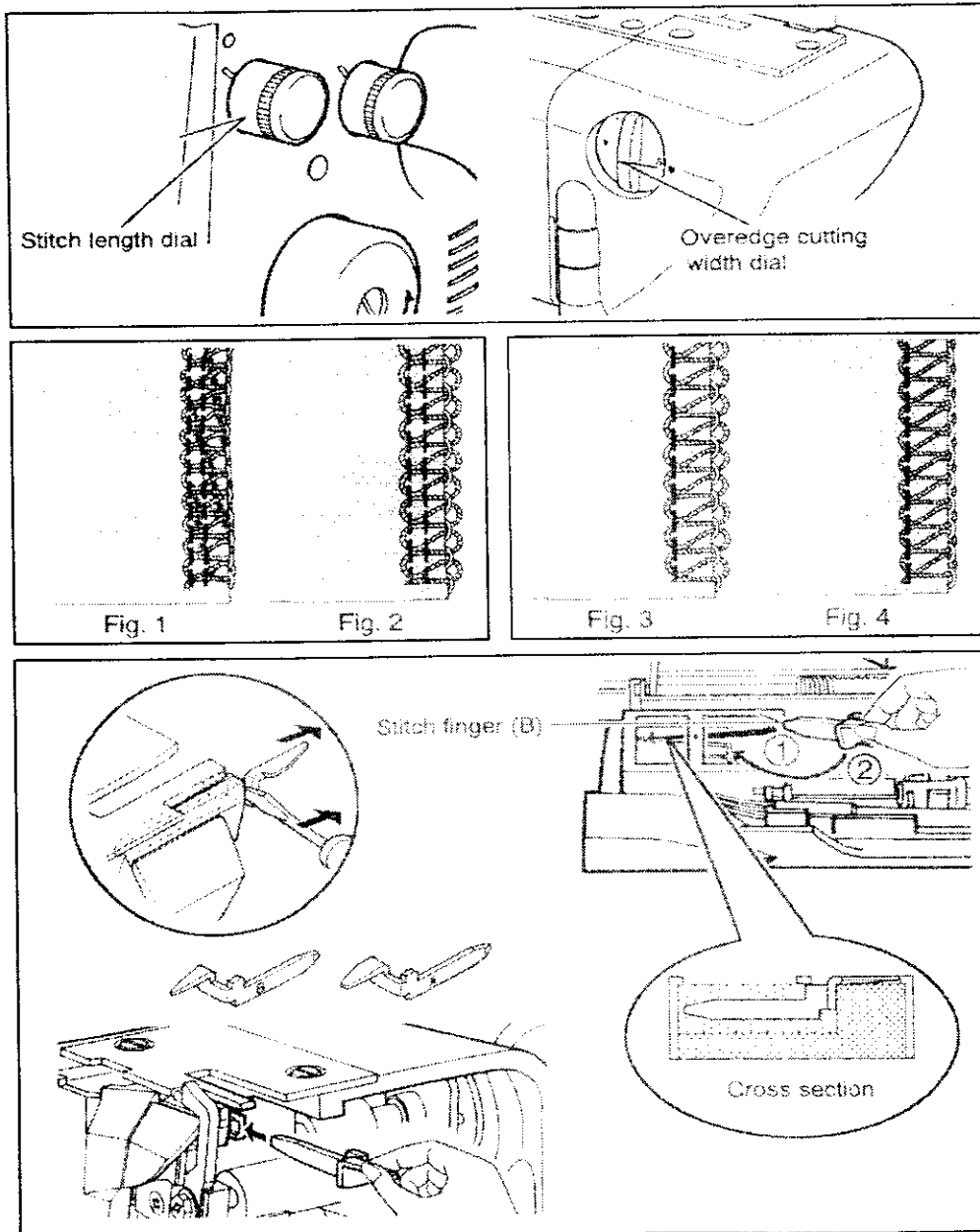

Stitch finger (B)

Loops may hang off the edge, when you sew with lightweight fabric using 3 threads (right needle only), and setting cutting width dial at 4-5(Fig.3). In such a case change the stitch finger(A) to (B) to get neat stitching(Fig.4)

DIFFERENTIAL FEED

The differential feed has two independent feed dogs, one front (A) and one rear (B).

Each feed dog has an individual feed mechanism which enables the feeding of material at a different ratio.

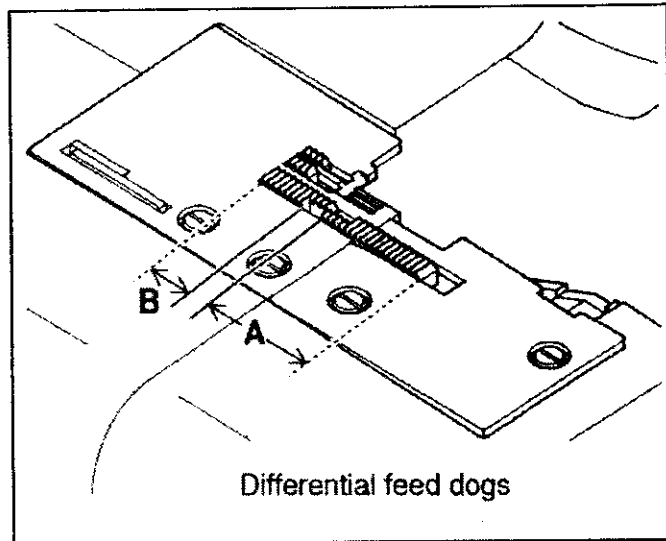

POSITIVE DIFFERENTIAL FEED

WHEN SET FOR POSITIVE DIFFERENTIAL FEED, the front feed dog (A) makes a longer stroke than the rear feed dog (B). This has the effect of accumulating material under the presser foot to offset the wavering on the fabric.

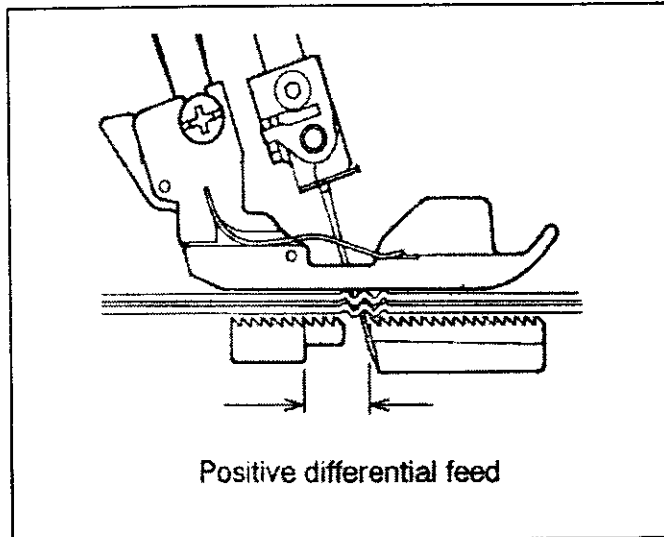

NEGATIVE DIFFERENTIAL FEED

WHEN SET FOR NEGATIVE DIFFERENTIAL FEED, the front feed dog (A) makes a shorter stroke than the rear feed dog (B). This has the effect of stretching material under the presser foot to offset the puckering on the fabric.

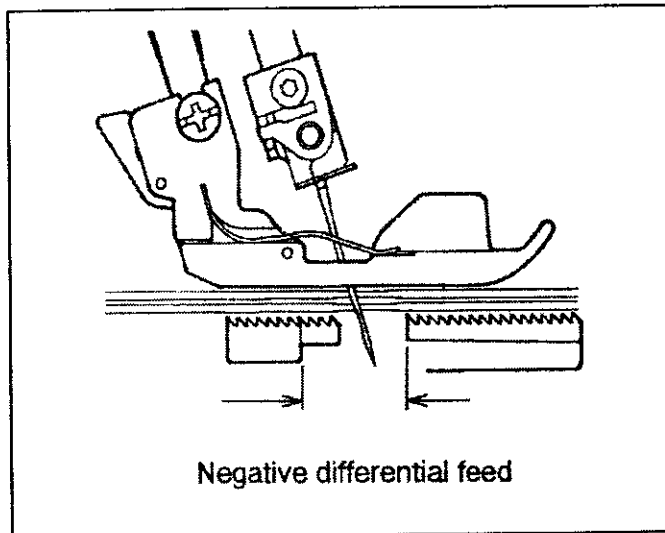

SETTING DIFFERENTIAL FEED

Set by simply turning the differential feed control dial in the direction desired referring to the chart below.

The adjustment can be made between 0.7 (negative effect) and 2 (Positive effect). These settings give the best ratio of feeding.

For normal sewing, the dial should be set at 1.

The dial can be reset even while sewing.

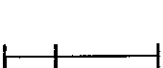
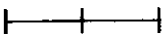
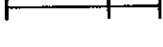
EFFECT AND APPLICATION	TYPE OF FEEDING	SETTING	FEED RATIO REAR:FRONT
Waver-free seams, Gathering	Positive differential feed	1-2	
No differential feed	Neutral feed	1	
Pucker-free seams	Negative differential feed	0.7-1	

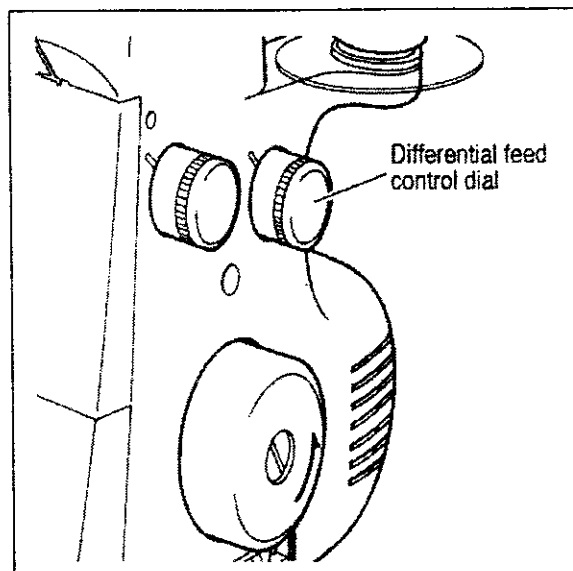

FOOT PRESSURE REGULATOR

Presser foot pressure has been correctly set at the factory, so you do not need to adjust it for most of ordinary sewing. If adjustment is necessary, turn the foot pressure regulator to higher number to increase or to lower number to decrease pressure.

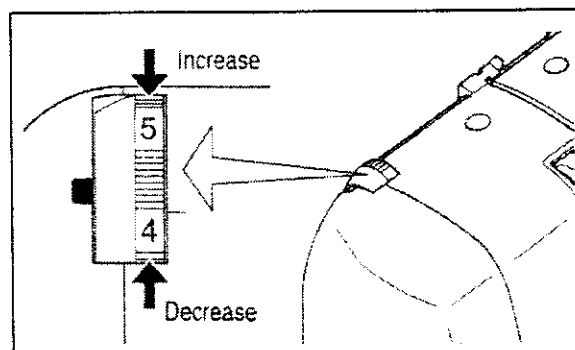

SEWING WITH EXTRA HEAVYWEIGHT FABRIC OR MULTIPLE LAYERS OF FABRIC

A wide range of fabric can be overlapped on this machine, but it is recommended to tighten screw as illustrated, when sewing with extra heavyweight fabrics or multiple layers of fabric. Open working table for adjustment.

Loosen the screw when sewing with light to normal weight fabric or turning overedge cutting width dial, or otherwise fabric may not be well cut. The machine is set for normal weight fabrics from the factory.

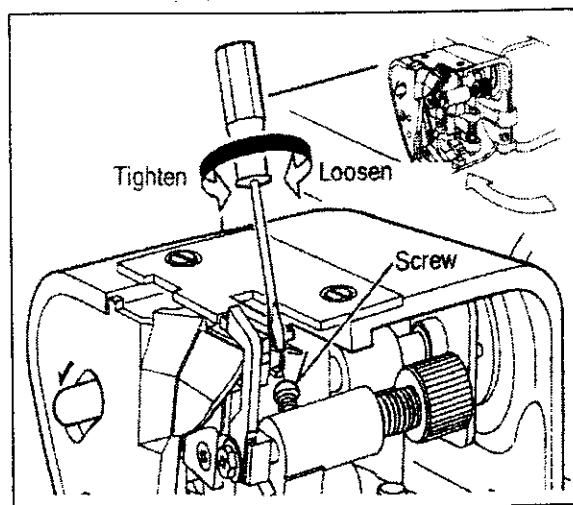

BASIC TECHNIQUES

TURNING OUTSIDE CORNERS WITHOUT CUTTING THREADS

1. When you reach the fabric edge, stop stitching with the needle above the fabric.
2. Raise the presser foot and gently pull on the thread chain just enough to clear the stitch finger.
3. Turn the fabric, lower the presser foot and begin stitching in the new direction. Fig. 1.

NOTE: When overlocking and trimming at the same time, cut the fabric along the new stitching line for about 3 cm, before turning the fabric. Fig. 2.

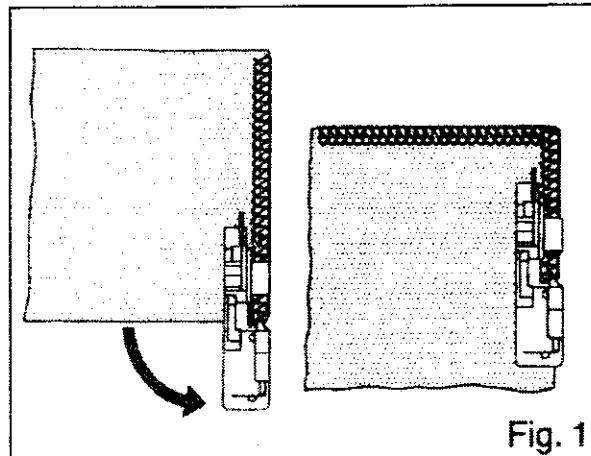

Fig. 1

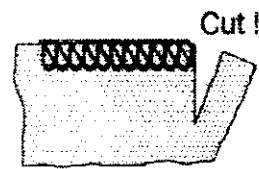

Fig. 2

TURNING CURVED EDGES

For inside curves, guide fabric gently with trimming line of the fabric under the right front of the presser foot (or a little to the left), applying pressure at point A in the direction of the arrow with your left hand, and at the same time applying a little opposite pressure at point B with your right hand. Fig.3.

For outside curves place under the presser foot in a similar manner but applying the pressure in the opposite directions. Fig. 4.

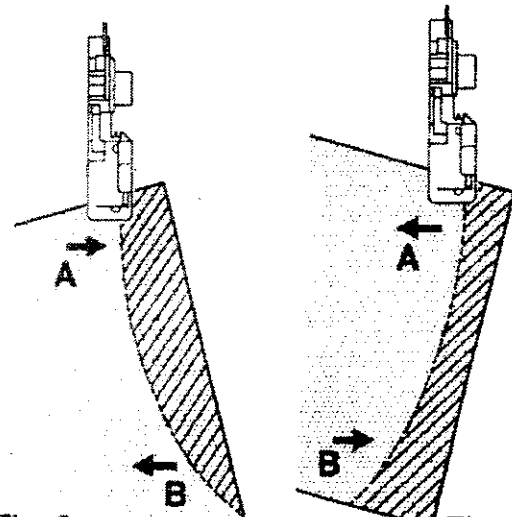
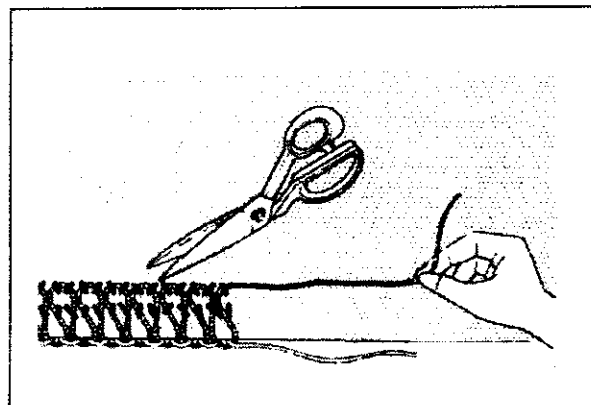

Fig. 3

Fig. 4

REMOVING STITCHES FROM SEWN FABRIC

To remove stitches already sewn, snip off needle thread (s) at intervals and pull out looper threads.



CORDED OVERLOCK,

Corded overlock can be used to strengthen shoulder, sleeve or side seams when joining or making up knitted garments. As a decorative feature you can use knitting yarn of contrasting colours to further enhance your garment. Your machine is equipped with a presser foot which has been designed to feed your cord or yarn to the left of the safety stitch or to the right. Follow instructions as follows:

1. Snap the detachable cord guide, in your accessory set onto the thread guide pole (Fig.1).
2. Place a "filler" cord, such as a crochet cotton, gimp, wool, knitting yarn, or shirring elastic at the rear of the machine spool pin. Pass the cord through the cord guides (1) and (2) and then through the left needle thread guide (3). See Fig. 1.
3. Insert the cord through either the front or rear hole (according to the operation, see diagrams Figures 2 and 3), in the presser foot and pass it under and to the rear of the foot.
4. Place the material to be sewn as normal. Start at slow speed observing if cord is feeding correctly and increase speed as needed.

FOR JOINING SHOULDERS OR SLEEVES, pass the cord through the front hole, ensuring that it is fixed between the left and right needle threads as it is guided through the front hole. (Fig.2).

FOR JOINING SIDE SEAMS, pass the cord through the rear hole, ensuring it is positioned to the right needle thread. (Fig.3)

FOR DECORATIVE EFFECTS, you may pass contrasting colours either through the front or rear hole or if you desire, pass cord or yarn through each hole.

FOR MAKING WAVED HEM WITH GUT (Fig.4), pass the gut through the rear hole and start ROLLED HEM (See page 16).

This is used for the hem of skirt, etc.

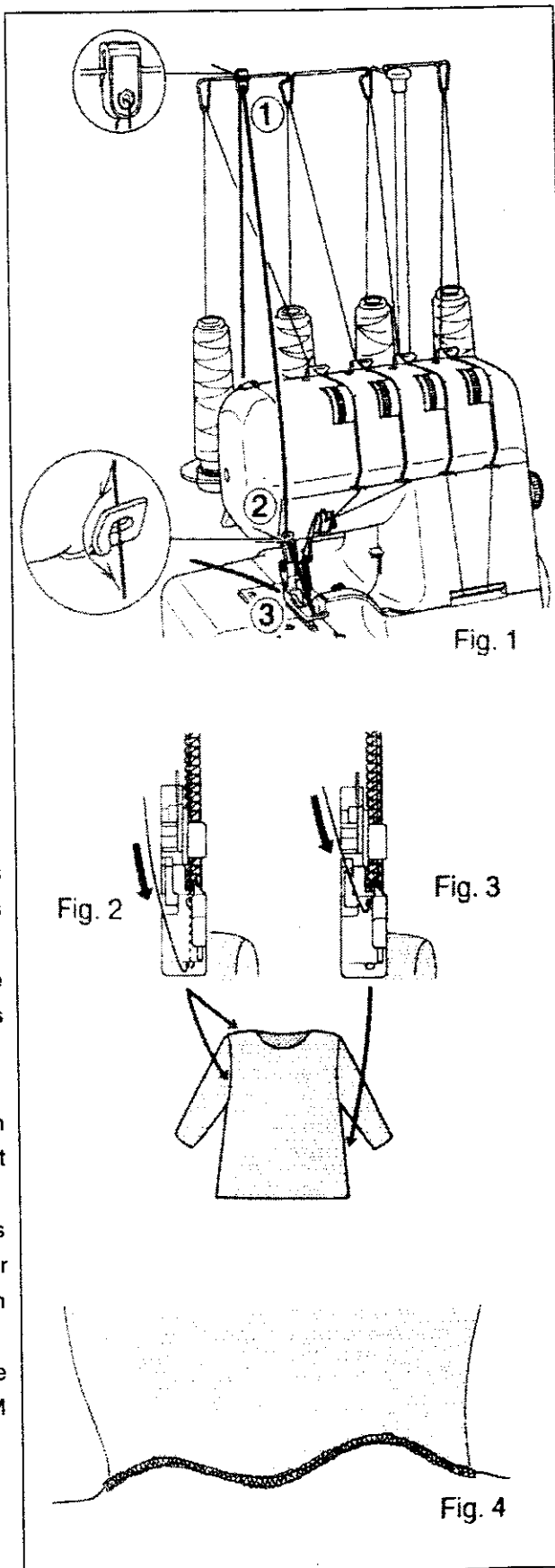

DECORATIVE EFFECTS

In addition to normal overlocking which is fully described in this instruction book, your machine can also be used for a number of decorative applications such as decorative top-stitching, butted seams, pin-tucking or making lengths of decorative braid. See below.

Decorative top-stitching-using only two threads or using three threads (flat seam)

Fold fabric along the line to be top-stitched and sew over the folded edge, making sure not to cut into the fold. Fig. A.

Unfold the fabric, pull the ends of the threads to the underside and press flat.

The final appearance can be enhanced by using buttonhole twist or embroidery thread on the lower looper.

Butted seams-using only two threads or using three threads (flat seam)

Place two pieces of fabric wrong sides together and overlock along the edge. Unfold and press.

By using different coloured fabrics and thread a pleasing 'patchwork' effect can be achieved.

Pin-tucking-using three threads

Fold fabric along a line to be pin-tucked and overlock sew along the folded edge, making sure not to cut into the folded edge of the fabric. (See page 25). Pull ends of threads to underside and press.

Making decorative braid-using three threads

Overlock over a cord braid, holding it carefully with both hands, making sure not to cut the edge. (See page 25).

NOTE: *If you use blind hem foot (option), decorative stitch is made easily.

**Reduce the upper looper tension when you use thick thread.

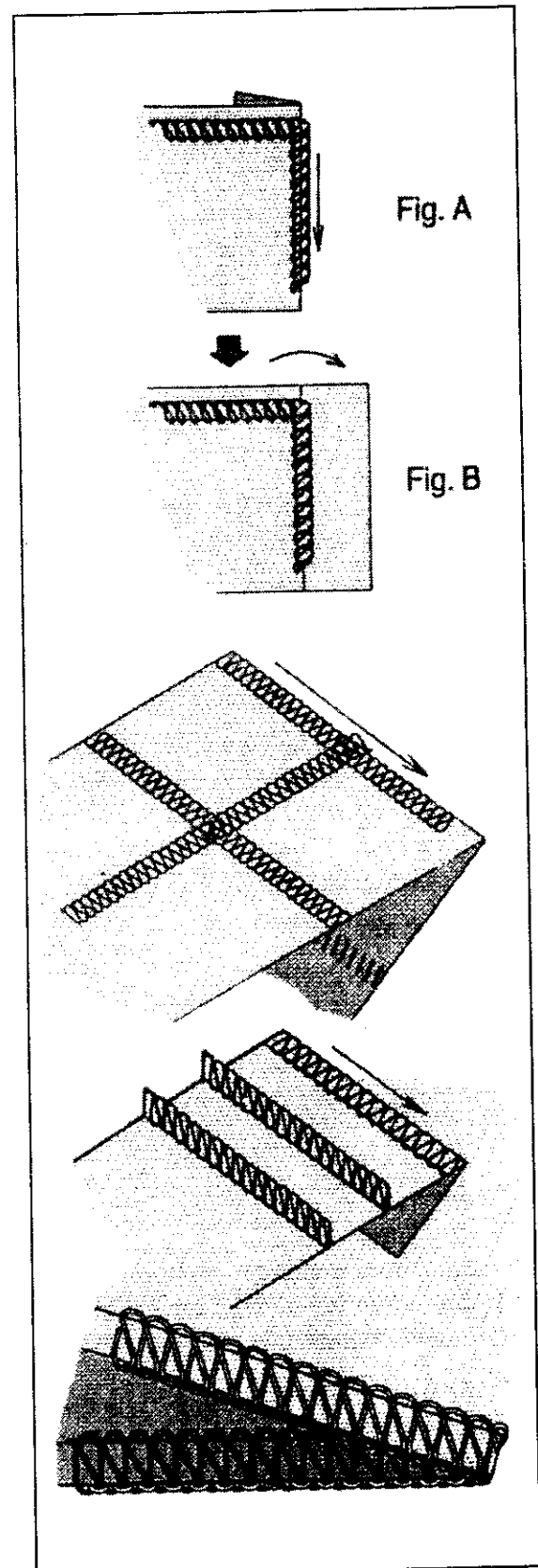

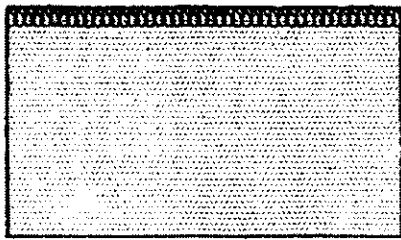

Pucker or waver-free seams

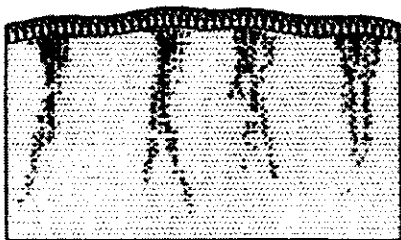

Puckering

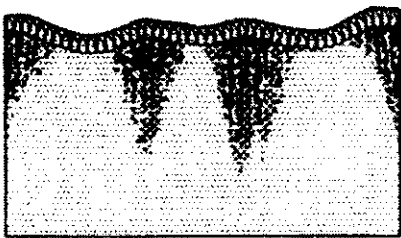

Wavering

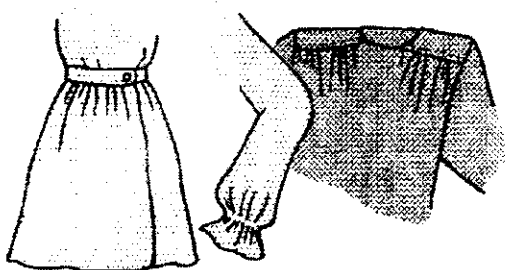

Gathering

DIFFERENTIAL FEED APPLICATIONS

Please refer to pages 19,20 DIFFERENTIAL FEED, Differential feed is designed to minimize puckering and wavering.

It is also very effective for gathering.

1. Puckering

Puckering tends to occur on woven or sheer fabrics.

To obtain pucker-free seams, set the differential feed control dial at less than 1.

2. Wavering

Wavering tends to occur on knitted or stretchable fabrics.

To obtain waver-free seams, set the differential feed control dial at more than 1.

3. Gathering

Differential feed makes gathering easier on lightweight fabric. Use it on waistlines, sleeve heads, sleeve bottoms and ruffles, etc.

Set the differential feed control dial between 1.5 and 2 to obtain the best gathering effect for your use.

IMPORTANT

The exact adjustment depends on the thickness and elasticity of fabric. Even the stitch length can influence the setting. The longer the stitches, the more the fabric is contracted.

Always do a test run with a piece of actual fabrics you use and find the best settings.

3. CARING FOR YOUR MACHINE

REPLACING MOVING CUTTER

Replace a moving cutter if it becomes blunt as follows. A spare cutter will be found in your accessories.

NOTE: You should not need to replace fixed cutter, which is made of special hard alloy material.

FIRST REMOVE THE POWER PLUG FROM THE SUPPLY SOCKET-OUTLET.

1. Loosen screw and take out moving cutter.
2. Close the working table. Lower cutter driving arm to its lowest position by turning the hand wheel towards you by hand. In this position, set replacement cutter in position and secure it with screw, ENSURING THAT THE EDGE OF THE MOVING CUTTER IS APPROXIMATELY 0.5 MM BELOW THE SURFACE OF THE FIXED CUTTER.

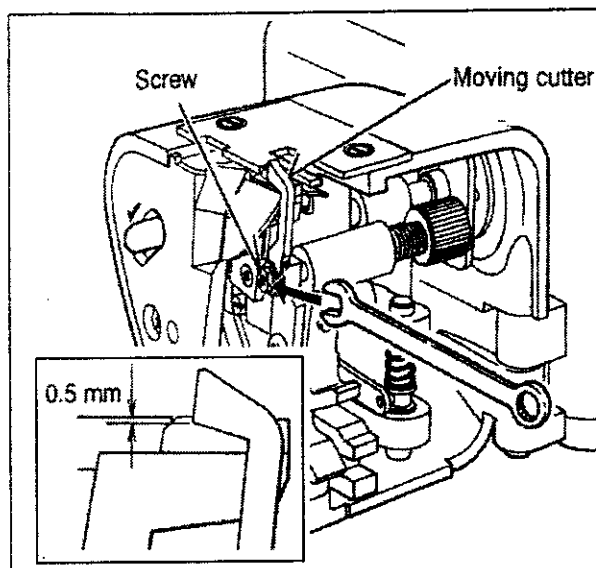

DISENGAGING MOVING CUTTER

If you want to sew without cutting, open the working table and disengage the moving cutter by pushing the cutter release knob to the left and turning it towards you as illustrated.

Ensure that fabric edge is not wider than overedge width selected or upper looper and needle can be damaged.

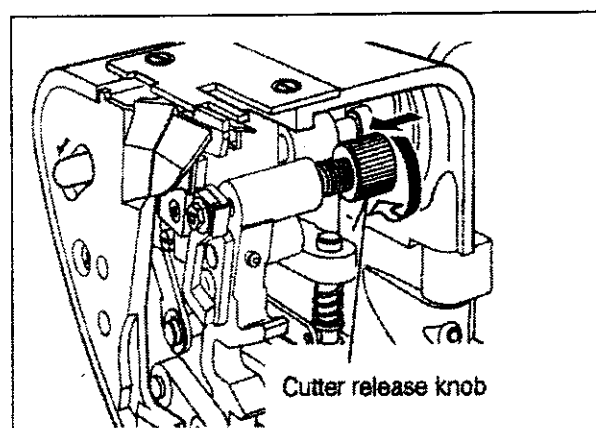

REMOVING FACE COVER

Disconnect from power supply before removing face cover.

Remove the screw and take off the face cover.

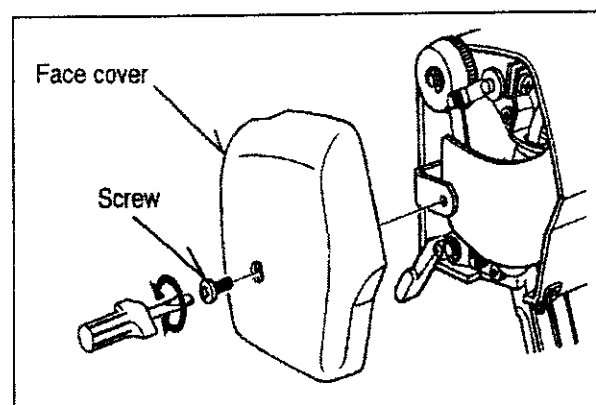

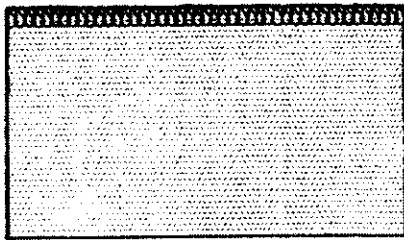

Pucker or waver-free seams

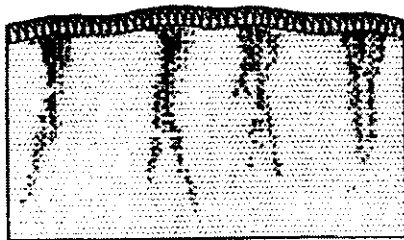

Puckering

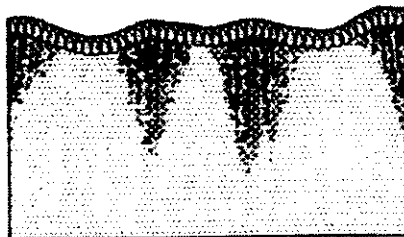

Wavering

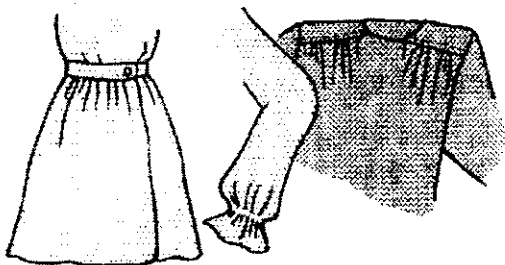

Gathering

DIFFERENTIAL FEED APPLICATIONS

Please refer to pages 19,20 DIFFERENTIAL FEED, Differential feed is designed to minimize puckering and wavering.

It is also very effective for gathering.

1. Puckering

Puckering tends to occur on woven or sheer fabrics.

To obtain pucker-free seams, set the differential feed control dial at less than 1.

2. Wavering

Wavering tends to occur on knitted or stretchable fabrics.

To obtain waver-free seams, set the differential feed control dial at more than 1.

3. Gathering

Differential feed makes gathering easier on lightweight fabric. Use it on waistlines, sleeve heads, sleeve bottoms and ruffles, etc.

Set the differential feed control dial between 1.5 and 2 to obtain the best gathering effect for your use.

IMPORTANT

The exact adjustment depends on the thickness and elasticity of fabric. Even the stitch length can influence the setting. The longer the stitches, the more the fabric is contracted.

Always do a test run with a piece of actual fabrics you use and find the best settings.

3. CARING FOR YOUR MACHINE

REPLACING MOVING CUTTER

Replace a moving cutter if it becomes blunt as follows. A spare cutter will be found in your accessories.

NOTE: You should not need to replace fixed cutter, which is made of special hard alloy material.

FIRST REMOVE THE POWER PLUG FROM THE SUPPLY SOCKET-OUTLET.

1. Loosen screw and take out moving cutter.
2. Close the working table. Lower cutter driving arm to its lowest position by turning the hand wheel towards you by hand. In this position, set replacement cutter in position and secure it with screw, ENSURING THAT THE EDGE OF THE MOVING CUTTER IS APPROXIMATELY 0.5 MM BELOW THE SURFACE OF THE FIXED CUTTER.

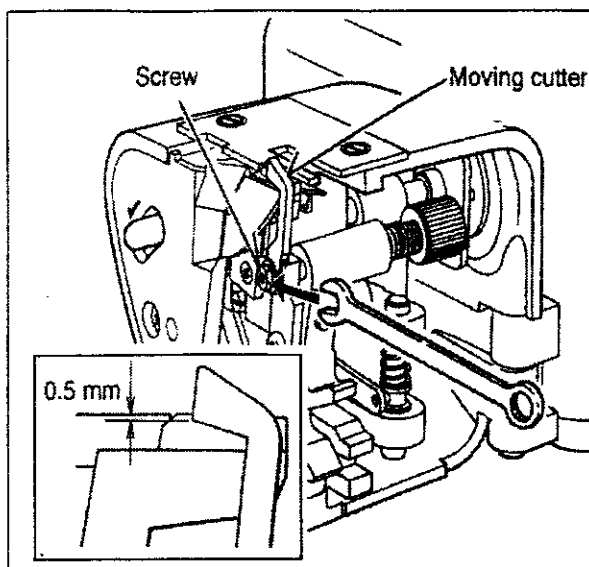

DISENGAGING MOVING CUTTER

If you want to sew without cutting, open the working table and disengage the moving cutter by pushing the cutter release knob to the left and turning it towards you as illustrated.

Ensure that fabric edge is not wider than overedge width selected or upper looper and needle can be damaged.

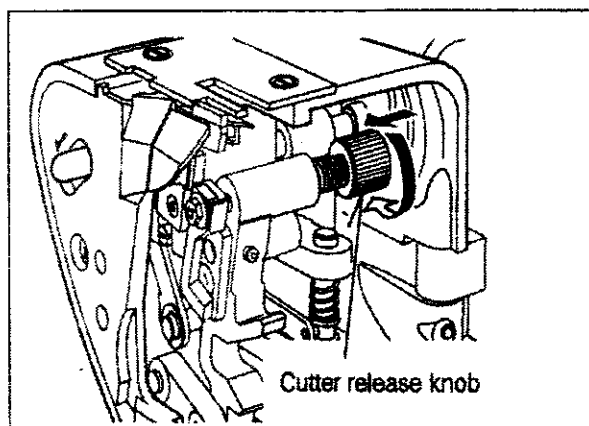

REMOVING FACE COVER

Disconnect from power supply before removing face cover.

Remove the screw and take off the face cover.

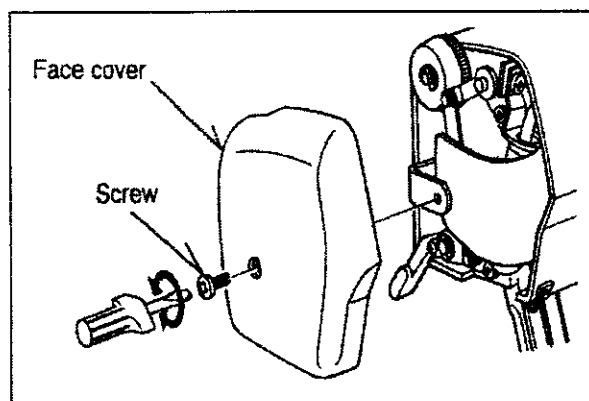

CLEANING AND OILING

To keep the machine running smoothly, keep it clean and lubricated at all times.

FIRST DISCONNECT MACHINE FROM POWER SUPPLY BY REMOVING PLUG FROM SOCKET-OUTLET.

1. Open the front cover and working table. Using the brush provided, remove dust and lint that have accumulated.
2. Apply a few drops of oil to the points indicated by arrows.
ALWAYS USE A GOOD QUALITY SEWING MACHINE OIL.
3. Remove each top cover with screw driver and remove dust and lint of inside with the brush.

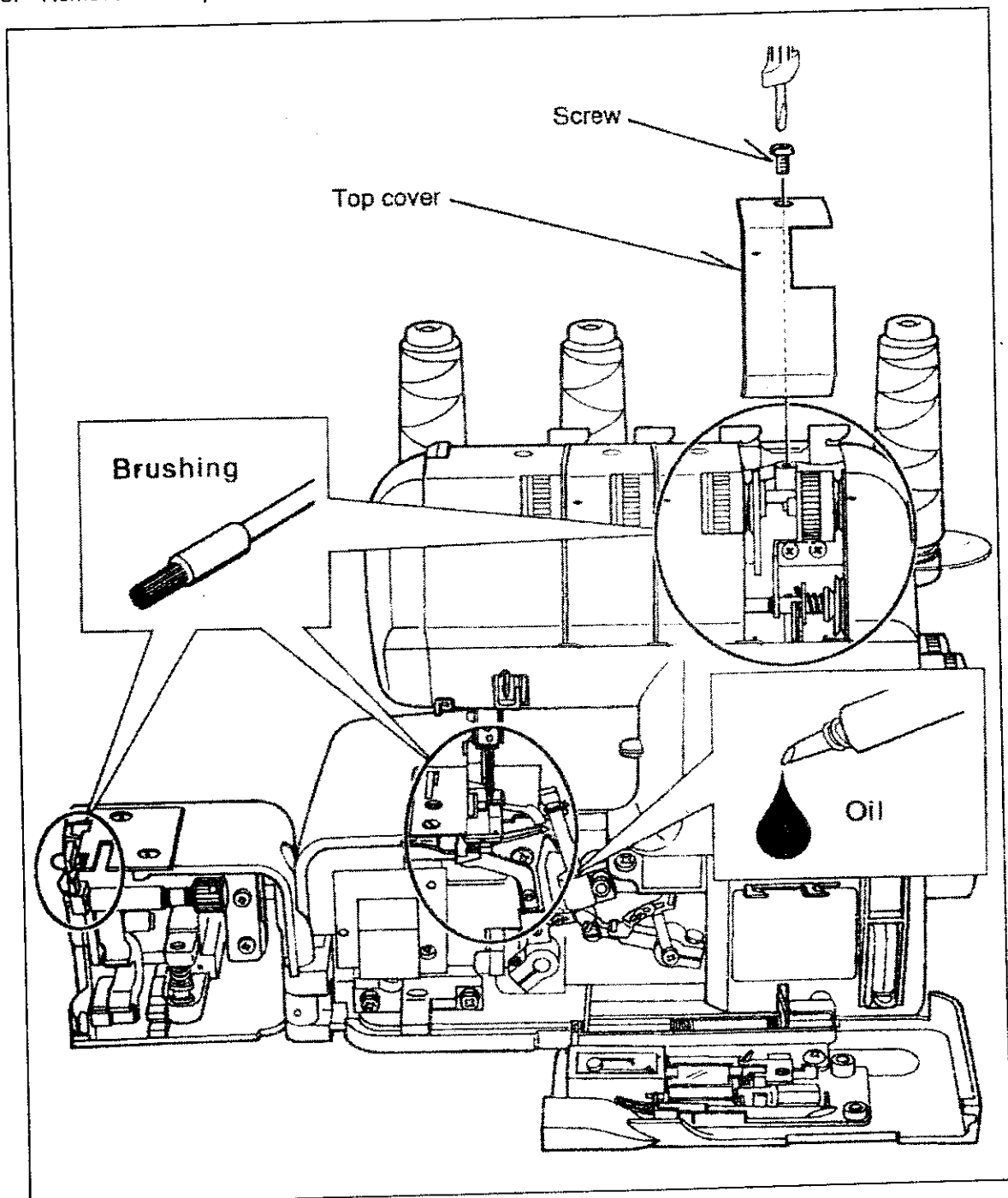

4. CHECKING PERFORMANCE PROBLEMS

PROBLEM	PROBABLE CAUSE	CORRECTION
Irregular Stitches	<p>Incorrect Thread Tension(s). Incorrect size Needle.</p> <p>Improper Threading. Pulling fabric. Loose Presser Foot.</p>	<p>Reset thread tension (s). Choose correct size Needle for Thread and Fabric.</p> <p>Re-thread machine. Do not pull Fabric; guide it gently. Reset Presser Foot.</p>
Breaking Needle	<p>Pulling fabric. Incorrect size Needle.</p> <p>Incorrect setting of Needle. Loose Presser Foot.</p>	<p>Do not pull Fabric; guide it gently. Choose correct size Needle for Thread and Fabric.</p> <p>Reset Needle. Reset Presser Foot.</p>
Puckering	<p>Incorrect Thread Tension (s). Bent or blunt Needle. Differential feed is set Incorrectly.</p>	<p>Reset Thread Tension (s). Insert new Needle. Set it at less than 1.</p>
Wavering	<p>Differential feed is set Incorrectly.</p>	<p>Set it at 1 or at more than 1. For knitted fabrics.</p>
Skipping Stitches	<p>Improper Threading. Incorrect size Needle.</p> <p>Bent or blunt Needle. Incorrect setting of Needle.</p>	<p>Reset thread machine. Choose correct size Needle for Thread and Fabric. Insert new Needle. Reset Needle.</p>
Breaking Threads	<p>Improper Threading. Bent needle.</p> <p>Thread Tension (s) too tight. Incorrect setting of Needle. Thread Spool tangled. Thread Guide Pole not extended.</p>	<p>Re-thread machine. Insert new Needle.</p> <p>Reset thread tension (s). Reset needle. Reset spool properly. Fully extend Guide Pole.</p>