

TM 170

COTTON TRIMMER MACHINE

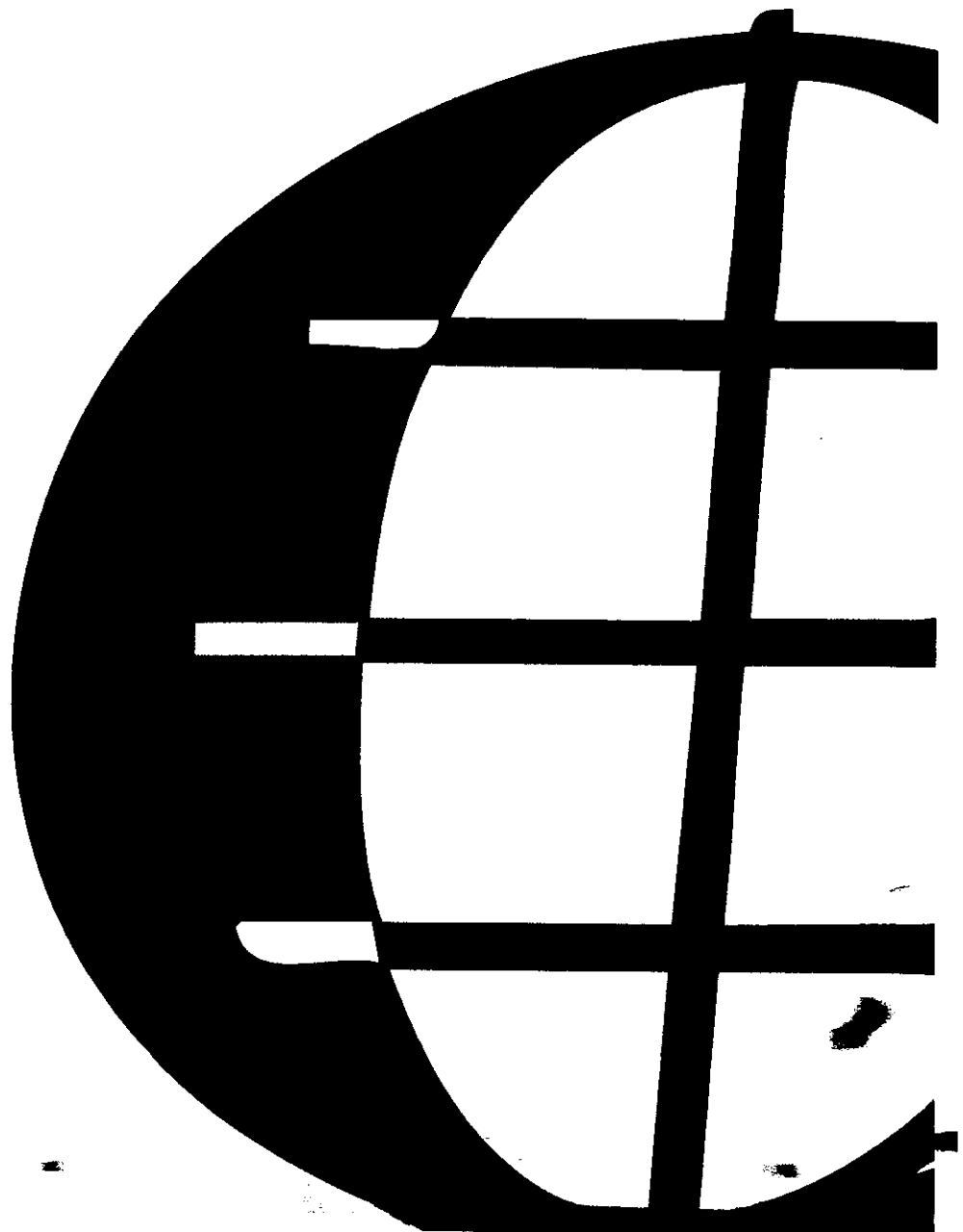

# ASSEMBLY

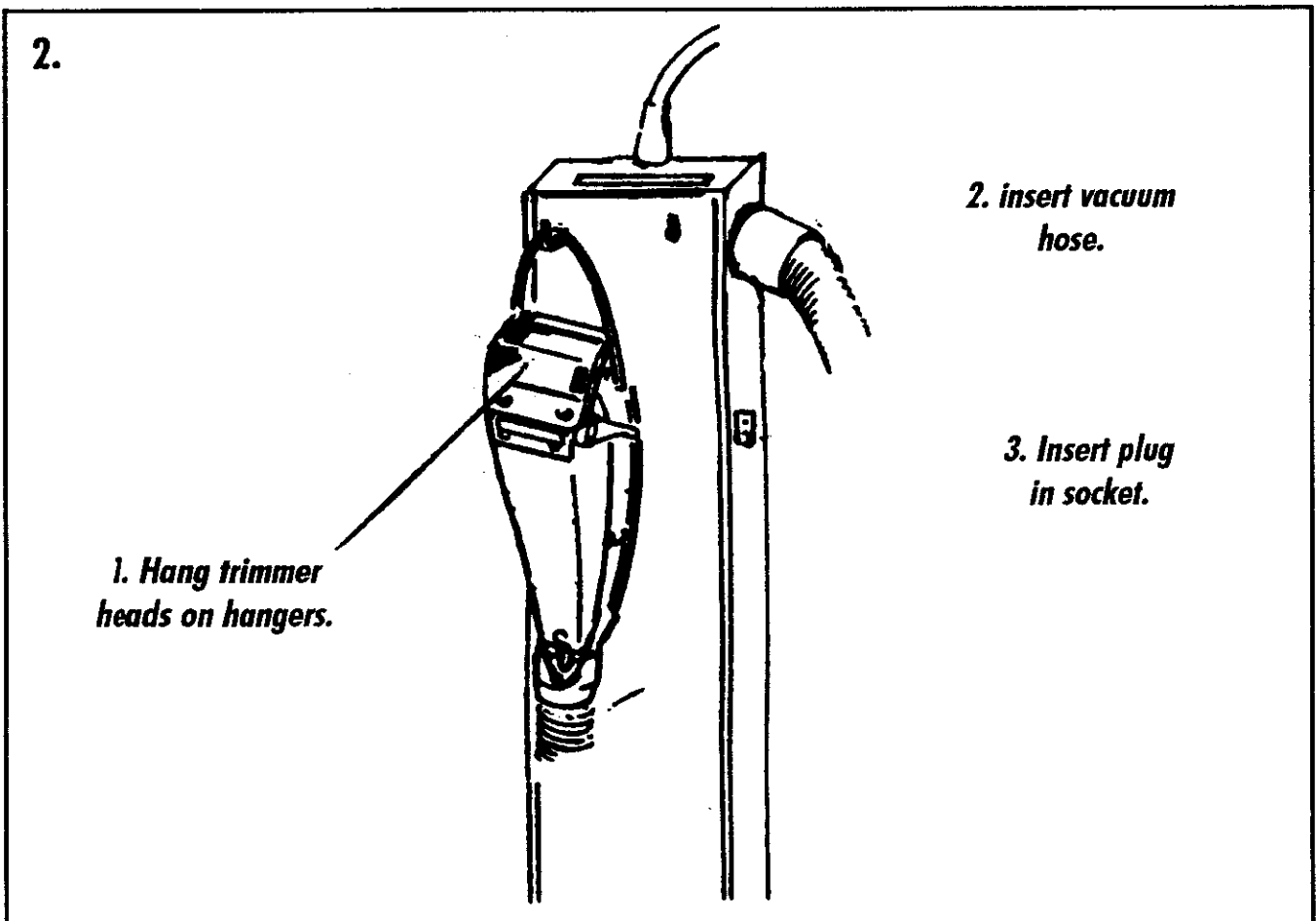
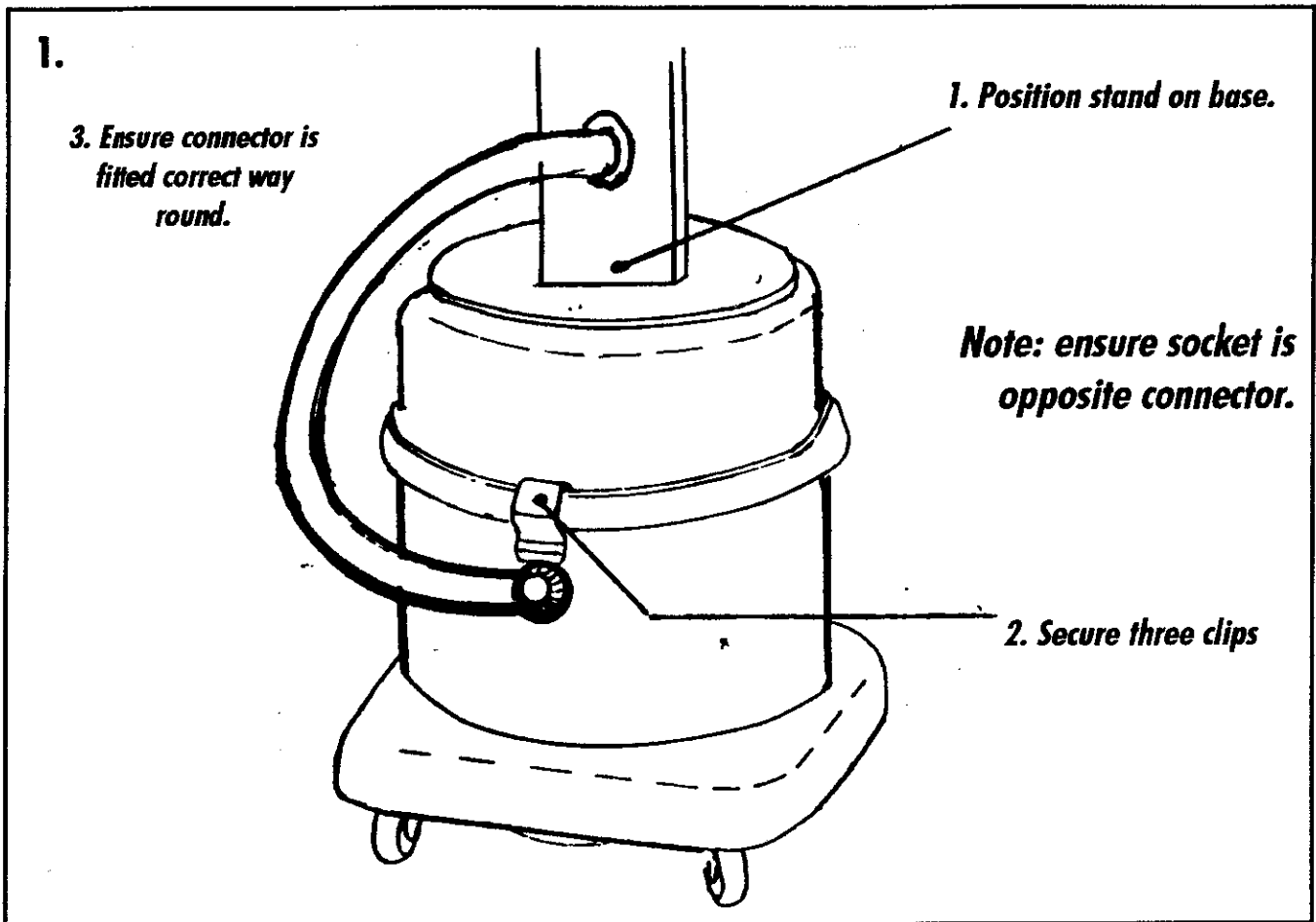

1.

1. Press main switch on - starts vacuum motor.



**Note: Connect mains plug to 220v ac single phase supply**

2.

1. Slide switch On - starts cutting action.

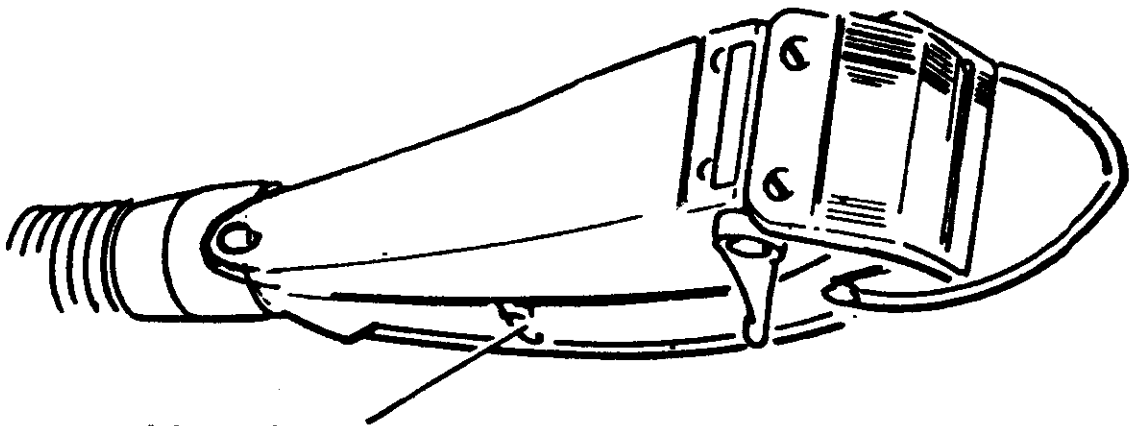

3.

1. Move trimmer head forwards and upwards

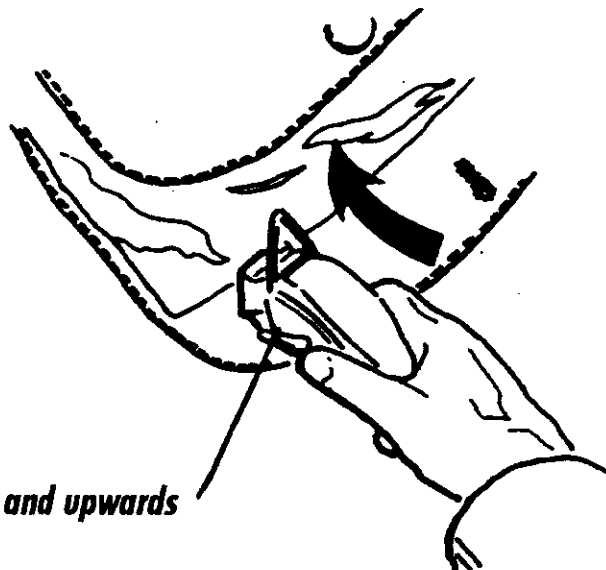

# WASTE DISPOSAL

1.

Lift mast and place on floor.

Open three securing clips.

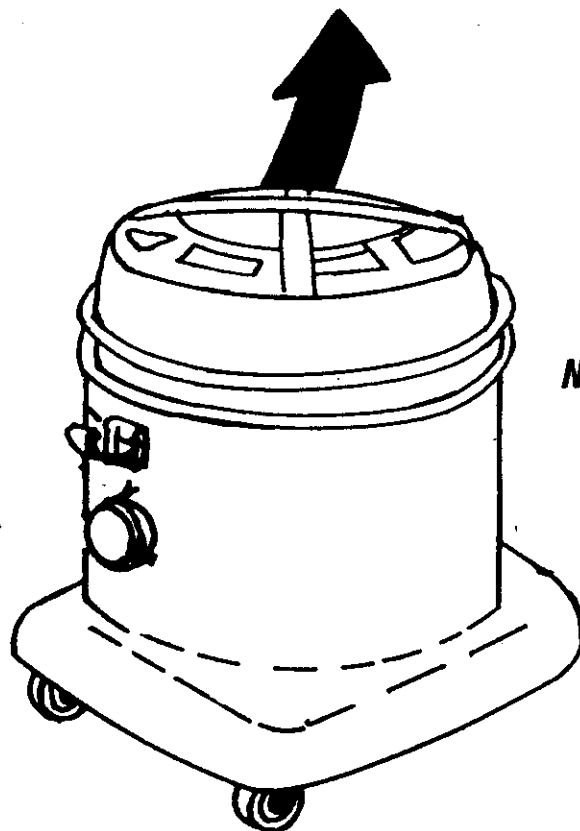

Remove waste bag and empty.

Note: When refitting waste bag, ensure rubber seal is seated correctly on rim of base.

2.

1. Slide switch off.

Twist and pull ring.

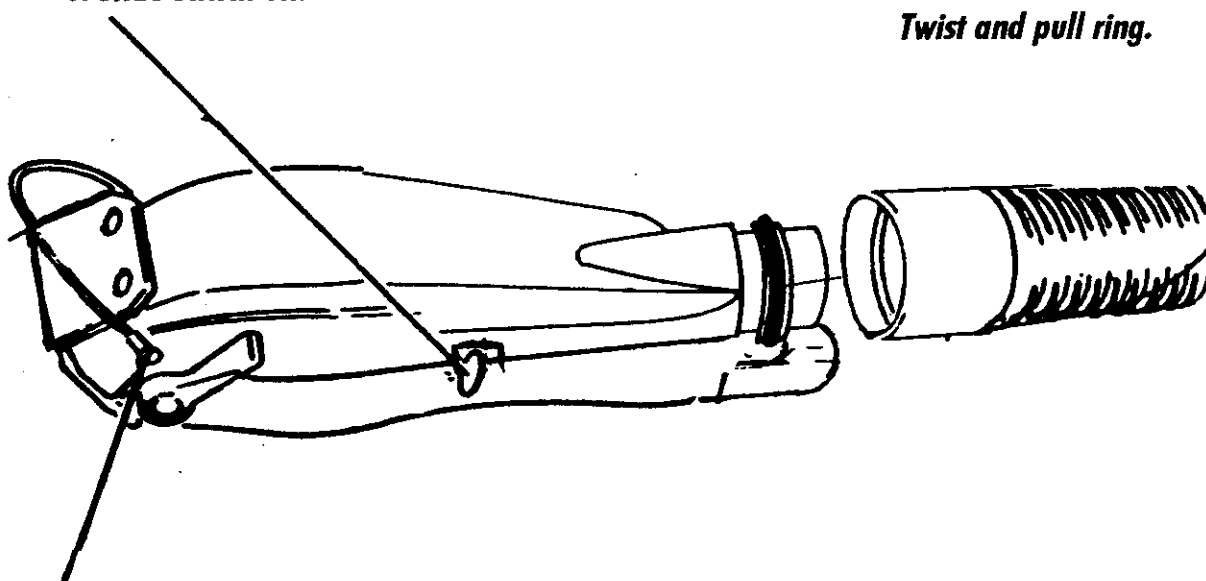

If necessary remove two screws to disassemble trimmer head.

Note: When reassembling, ensure wire sits in the groove under vacuum hose.

# TRIMMER HEAD SETTING INSTRUCTIONS

## A) WITH BLADE IN OPEN POSITION:

The stationary and moving blades should be level at the tips.

To adjust: Slacken screws A position stationary blade check position and tighten screw A.

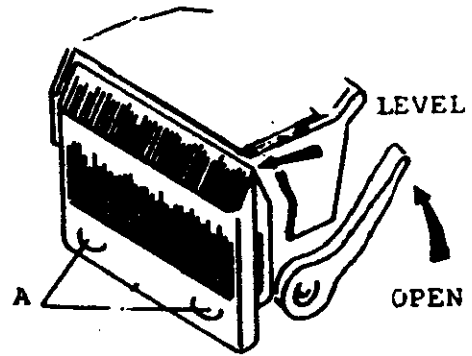

## B) WITH BLADE IN CLOSED POSITION:

The gap between the thread guard and the stationary blade tip should be no more than 1-2mm.

To adjust: Slacken screw C and position to suit.

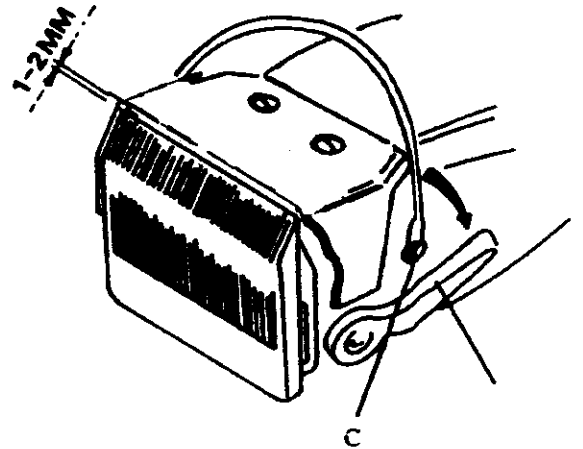

## WITH BLADE IN CLOSED POSITION:

Thread guard and stationary blade should present level surface.

To adjust: Slacken screws D and position thread guard D to suit.

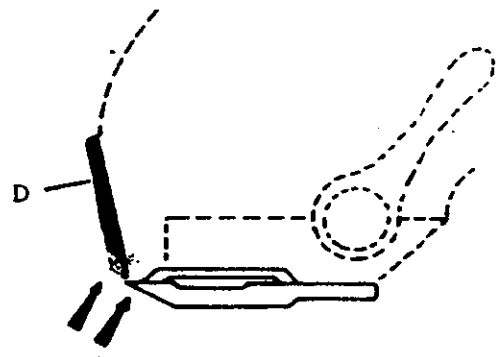

**THE AMOUNT OF THREAD LEFT AFTER TRIMMING CAN BE ADJUSTED CAN BE ADJUSTED BY ALTERING THE HEIGHT OF THE THREAD GUARD TO THE STATIONARY BLADE.**

## MAINTENANCE

**BLADES MUST** BE OILED TWICE DAILY USING A FINE MINERAL OIL.  
(Example: Mobil oil whiterex 408 or equivalent)

**DO NOT USE** - SILICON OILS OR SPRAY. THIS WILL STOP THE MACHINE FROM WORKING.

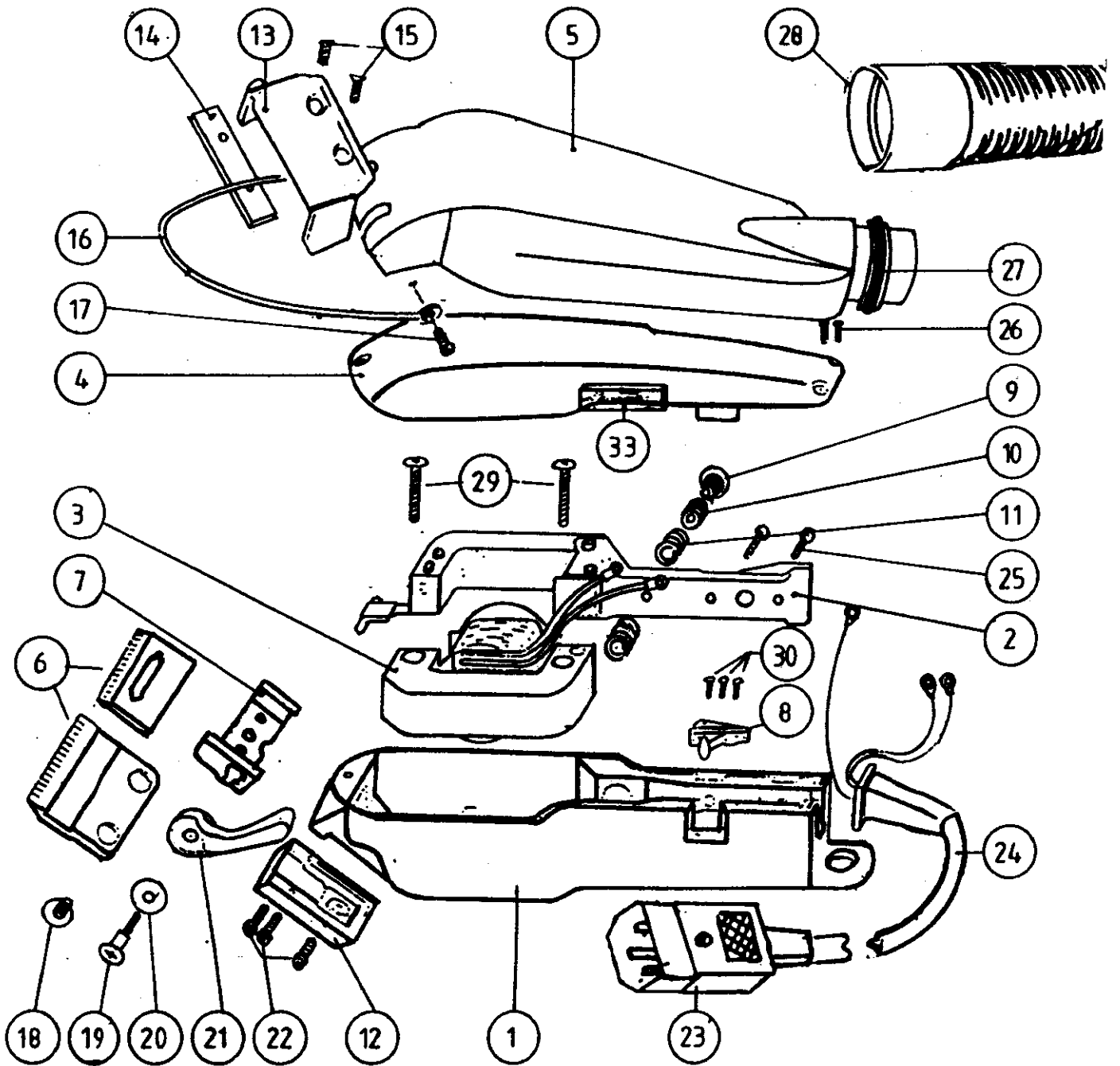

<b>Pos.</b>	<b>Part No.</b>	<b>Description</b>
1	TM 98442 - 002	case super taper
2	TM 98505	arm
3	TM 98524	coil
4	TM 98536 - 461	lid super taper
5	TM 9WA 9223	vac main housing
6	TM 91006	adjusto - lock blade set
7	TM 91248	blade slide
8	TM 98108 - 001	switch
9	TM 98115	power screw cap
10	TM 98117	power screw
11	TM 90520	red spring
	TM 90521	yellow spring
12	TM 98407 - 001	nose piece
13	TM 9150 - 6	thread guard
14	TM 9150 - 5	guard plate screws
15	TM 9150 - 11	screw
16	TM 9T3050	Bowden gun hanger
17	TM 9150 12	lid screws
18	TM 90508 - 100	blade screw
19	TM 90512	blade lever screw
20	TM 98218	lever washer
21	TM 98226	lever black
22	TM 90191 - 001	terminal screw
23	TM 9150 - 13	mains lead
24	TM 9150 - 14	clipper cord
25	TM 91567	arm screw
26	TM 90 - 195	led screw
27	TM 9150 - 15	O ring
28	TM 9150 - 16	tube
29	TM 90503	coil screw
30	TM 90 - 191 - 001	terminal screw
31	TM 9WA 3320	clipper oil 10 ml
32	TM 9WA 3310	clipper oil 118,3 ml
33	TM 9150 - 25	sponge rubber

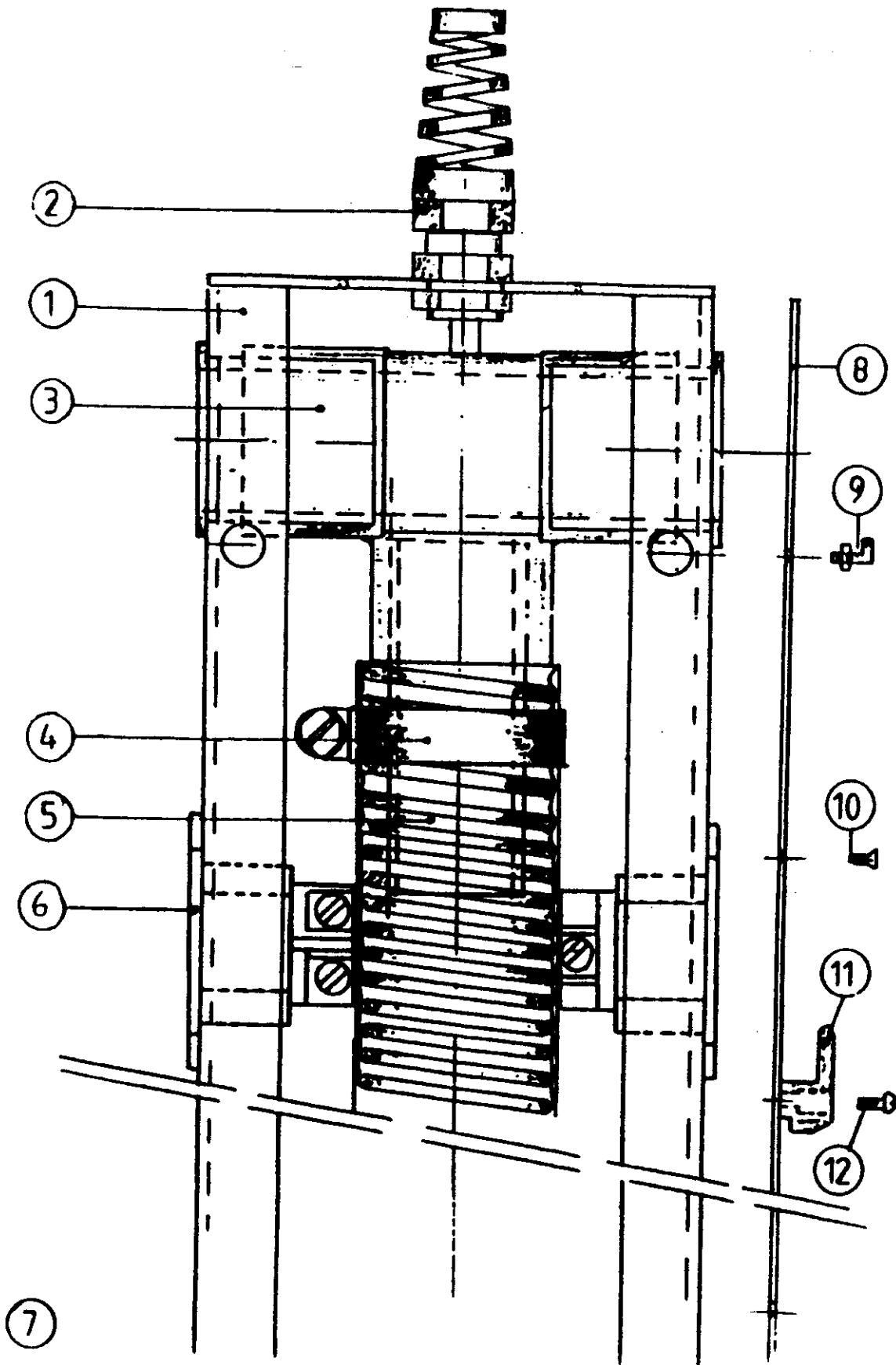

<b>Pos.</b>	<b>Part No.</b>	<b>Description</b>
1	TM 9150 - 1	Mast assembly complete
2	TM 9150 - 17	mains lead grommet
3	TM 9150 - 18	T-vac housing
4	TM 9150 - 19	clamp
5	TM 9150 - 20	vacuum tube
6	TM 9150 - 21	socket
7	TM 9150 - 22	rubber ring
8	TM 9150 - 2	cover
9	TM 9150 - 23	hangers
10	TM 9150 - 24	screw
11	TM 9227019	cable hook
12	TM 9221151	pozi-pan screw

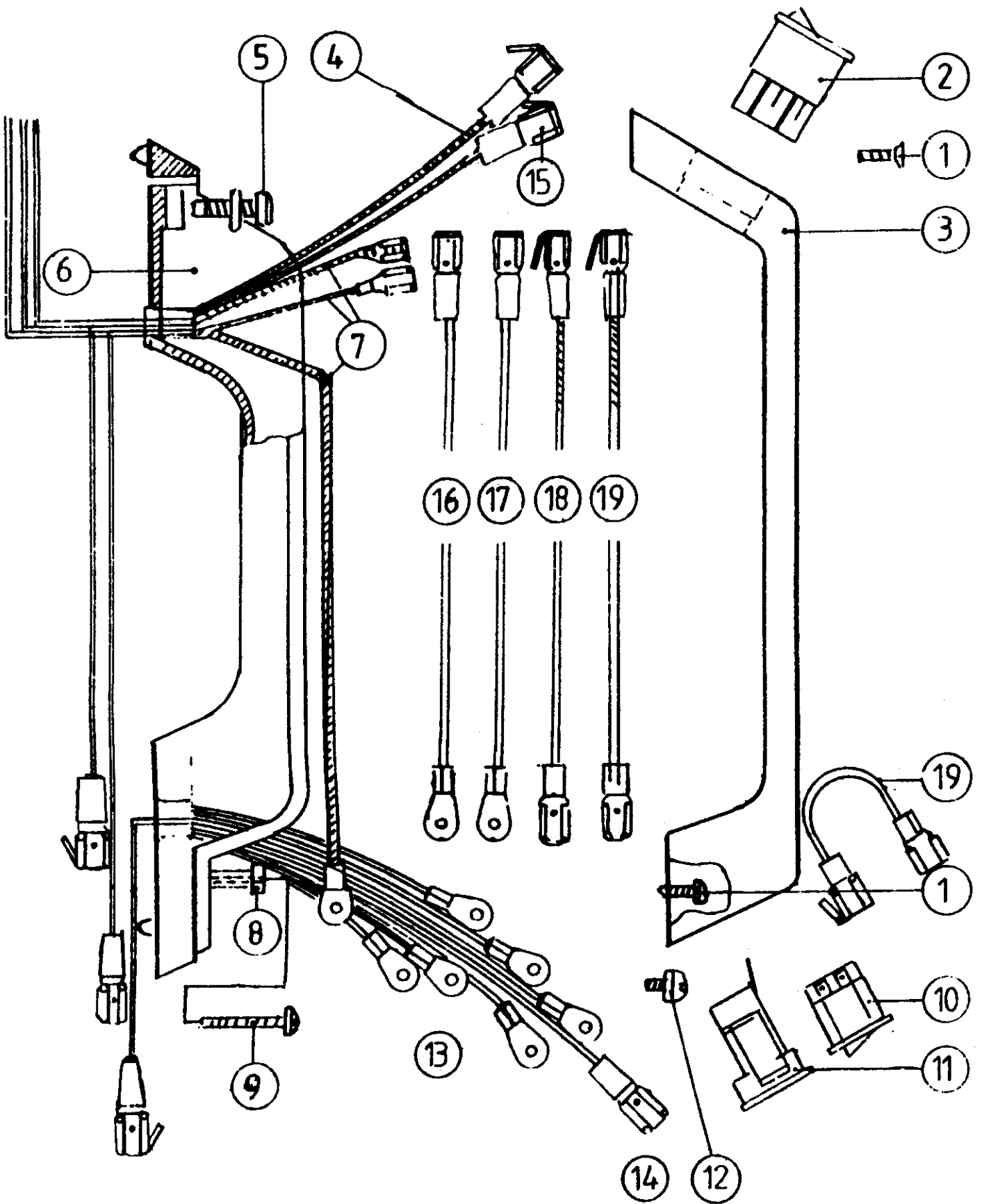

<b>Pos.</b>	<b>Part No.</b>	<b>Description</b>
1	TM 9219107	no. 6 x 5/8" plastite screw
2	TM 9220286	switch
3	TM 9206249	handle cover wire black
4	TM 9150 - 26	wire 110 cm 43 1/4"
5	TM 9219047	sems screw
6	TM 9206187	handle body
7	TM 9150 - 27	12m - 470 inch wire
8	TM 9220078	earthing spacer
9	TM 9219274	earthing screw
10	TM 9220244	boulble pol switch green/black
11	TM 9220130	power take off scocket
12	TM 9219090	sems screw
13	TM 9150 - 28	20cm - 7 7/8 inch wire
14	TM 9150 - 29	85cm - 33 1/2 inch wire brown
15	TM 9150 - 30	110cm - 43 1/4 inch wire white
16	TM 9220420	21cm - 82 5/8 inch wire brown
17	TM 9150 - 31	20cm - 7 7/8 inch wire blue
18	TM 9220365	18cm - 7 inch wire brown
19	TM 9220330	9cm - 3 1/2 inch wire white

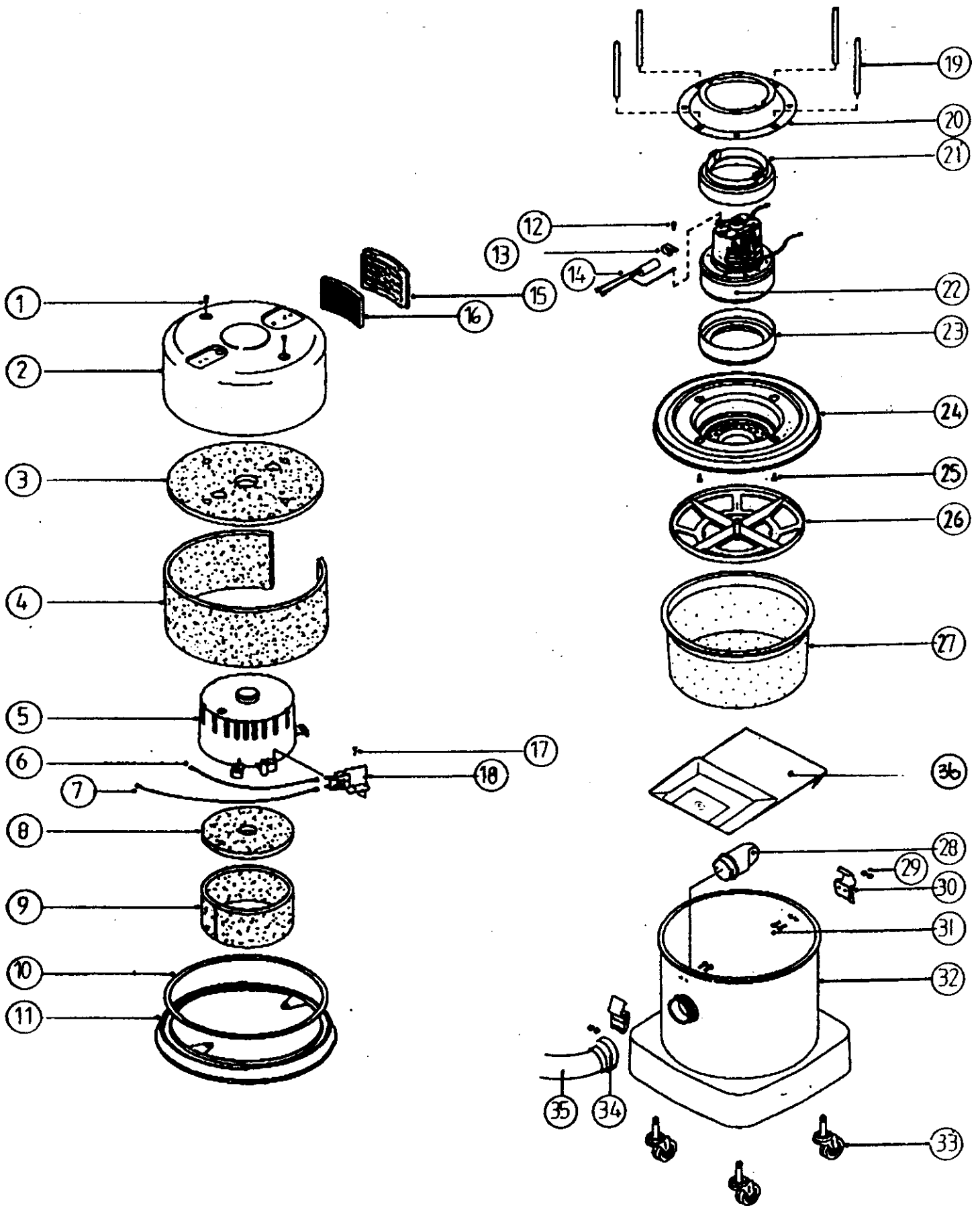

<b>Pos.</b>	<b>Part No.</b>	<b>Description</b>
1	TM 9219047	sems screw
2	TM 9401194	black head top
3	TM 9203005	top felt
4	TM 9203001	side felt (NVQ382B)
	TM 9203009	side felt (NVQ382)
5	TM 9229149	noise reduction pod
6	TM 9220420	210mm long brown link wire
7	TM 9150-30	370mm long brown link wire
8	TM 9203007	felt disc
9	TM 9203008	side felt insulation
10	TM 9212052	inseal (920mm long)
11	TM 9202006	buffer ring
12	TM 9219095	toptite sems screw
13	TM 9219283	securing clip
14	TM 9320016	suppressor
15	TM 9225064	outlet grill (NVQ382)
16	TM 9206260	air diffuser pad (NVQ382)
17	TM 9219318	plastite 250 screw
18	TM 9220285	speed control
19	TM 9208009	102,5mm long aluminium spacer
20	TM 9401189	black top motor housing
21	TM 9202066	top motor gasket
22	TM 9205032	230V motor
23	TM 9202065	bottom motor gasket
24	TM 9401190	black bottom motor housing
25	TM 9219047	sems screw
26	TM 9209050	filter grid
27	TM 9207102	white filter assembly
28	TM 9227004	bag connector
29	TM 9219076	staytight nylon insert nut
30	TM 9206038	toggle
31	TM 9219330	countersunk screw
32	TM 9300069	blue container
33	TM 9204059	2" castor
34	TM 9216006	swivel connector $\varnothing$ 32mm-1¼"
35	TM 9213200	tube 100mm $\varnothing$ 32mm-1¼"
36	TM 9218005	filter bags NVM-2B

# Notes

# Notes