

GLOBAL

US 63900 CH
Chainstitch hemming machine

**Spare parts
manual**

目录

A. 机头部件及润滑件	5
B. 罩盖及夹线部件	7
C. 传动轴、针杆及压脚提升机构	11
D. 针送料操纵部件	13
E. 压脚及上送料轮机构	15
F. 弯针及松线部件	17
G. 送料轮操纵部件	21
H. 附件	23
I. 电控部件	25
J. 自动剪线部件	27

A. MAINFRAME AND MISCELLANEOUS OILING PARTS	5
B. MISCELLANEOUS COVERS AND NEEDLE TENSION PARTS	7
C. DRIVE SHAFTS, NEEDLE BAR , FOOT LIFTER MECHANISM	11
D. NEEDLE FEED DRIVING PARTS	13
E. PRESSER FEET AND TOP FEED ROLLER MECHANISM	15
F. LOOPER AND TENSION RELEASE PARTS	17
G. FEED ROLLER DRIVING PARTS	21
H. ACCESSORIES	23
I. COMPONENT FOR ELECTRIC CONTROLLER	25
J. COMPONENT FOR TRIMMER	27

机头部件及润滑件
MAINFRAME AND MISCELLANEOUS OILING PARTS

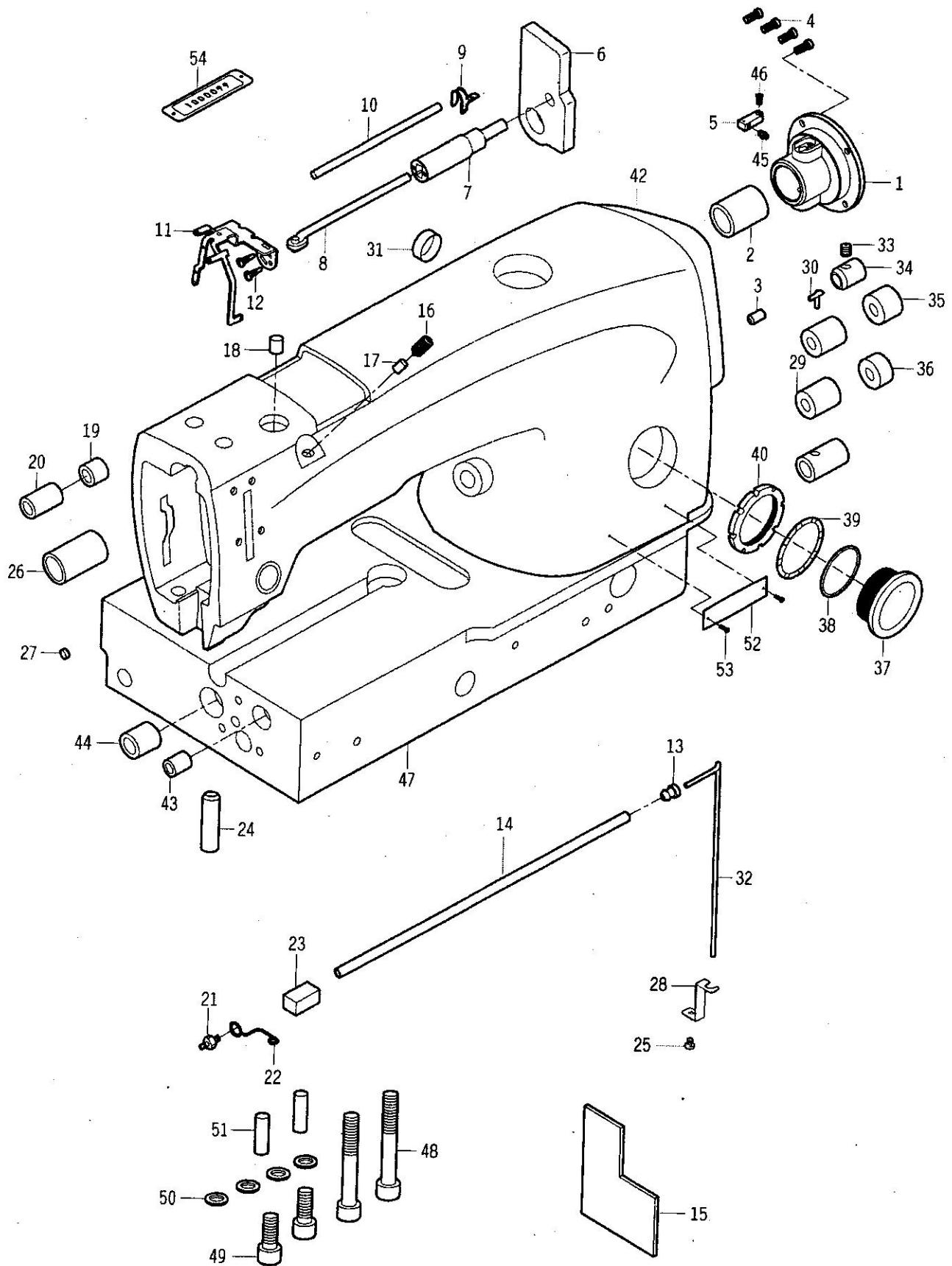

机头部件及润滑件.MAINFRAME AND MISCELLANEOUS OILING PARTS

序号	图号	零部件名称	NAME OF PARTS	数量
1	9A-1	轴承座	Main Shaft Bushing Housing, including bushing	1
2	9A-2a	轴承套	Bushing	1
3	9A-3a	塞头	Plug, for bed	1
4	9A-4	螺钉 23/128-32 × 11	Screw 23/128-32 × 11	4
5	9C-5A-16	二通喷嘴	Nozzle	1
6	9A-6a	油毡	Felt Baffle	1
7	9A-7a	油管	Head Oil Supply Line	1
8	9A-8	油毡	Felt	1
9	9A-9a	弹性线夹	Spring Clip	1
10	9A-10	油毡	Roll Felt	1
11	9A-11	机头加油组件	Head Oiler Assembly	1
12	9A-12	螺钉 35/256-32	Screw 35/256-32	2
13	9A-13	限位胶环	Retaining Grommet	1
14	9A-14	油管组件	Oil Siphon Connecting Tube	1
15	9A-60A	油毡	Oil Felt	1
16	9A-16a	螺钉 M8 × 16	Plug Screw M8 × 16	1
17	9A-17	油毡	Oil Felt	1
18	9A-18	油毡	Oil Felt	1
19	9A-19a	针杆摆轴右轴套	Needle Bar Frame Rocker Shaft Bushing, right	1
20	9A-20	针杆摆轴左轴套	Needle Bar Frame Rocker Shaft Bushing, left	1
21	9A-21	螺栓 39/256-40	Stud 39/256-40	1
22	9C-5A-19	管夹	Cannulation Clip	1
23	9A-23	油毡	Oil Tube	1
24	9A-26	压紧杆轴套	Presser Bar Bushing, lower	1
25	9B-7a	螺钉 37/256-40 × 4.5	Screw 37/256-40 × 4.5	1
26	9A-28a	上轴左轴套	Upper Main Shaft Bushing, left	1
27	9A-27a	塞头	Plug	1
28	9A-34	油管支架	Oil siphon Primer Position Bracket	1
29	9A-35b	齿轮轴左轴套	Reduction Gear Shaft Bushing, left	2
30	9A-37	油毡	Bed Oil Drain Hole Felt	1
31	9A-38	塞	Bed Plug	1
32	9A-39	油管	Oil siphon Priming Cup	1
33	9A-41	油毡	Oil Wick, for bushing housing	1
34	9A-42	中间齿轮轴轴套	Middle Reduction Gear Stud Bushing	1
35	9A-43b	上齿轮轴右轴套	Upper Reduction Gear Shaft Bushing, right	1
36	9A-44b	下齿轮轴右轴套	Lower Reduction Gear Shaft Bushing, right	1
37	9A-45	油标组件	Oil Gauge Assembly	1
38	9A-48	O形圈 40	"O" Ring 40	1
39	9A-47	弹簧垫圈	Spring Washer	1
40	9A-46a	圆螺母 25/16-16	Nut 25/16-16	1
41	9A-49a	旋梭驱动轴右轴套	Hook Drive Shaft Bushing, right	1
42	9-3A-57	机壳	Mainframe	1
43	9A-56a	旋梭轴右轴套	Hook Shaft Bushing, right	1
44	9A-57a	旋梭驱动轴左轴套	Hook Drive Shaft Bushing, left	1
45	9C-5-9	油管接头	Vitta Tie-in	1
46	9C-5A-22	螺钉 M3x12	Screw M3 × 12	1
47	9-3A-58	底板	Bed	1
48	9A-63	内六角螺栓 M10 × 65	Screw M10 × 65	2
49	8A-34b	内六角螺钉 M10 × 25	Screw M10 × 25	2
50	9A-65	垫圈 10.5 × 16 × 1.6	Washer 10.5 × 16 × 1.6	4
51	9A-66	定位销 9.5	Pin 9.5	2
52	9A-67	铭牌	Lable	1
53	2A-14-14	铆钉 1.5	Rivet 1.5	4
54	9A-70	编号牌	Serial number	1

罩盖及夹线部件

MISCELLANEOUS COVERS AND NEEDLE TENSION PARTS

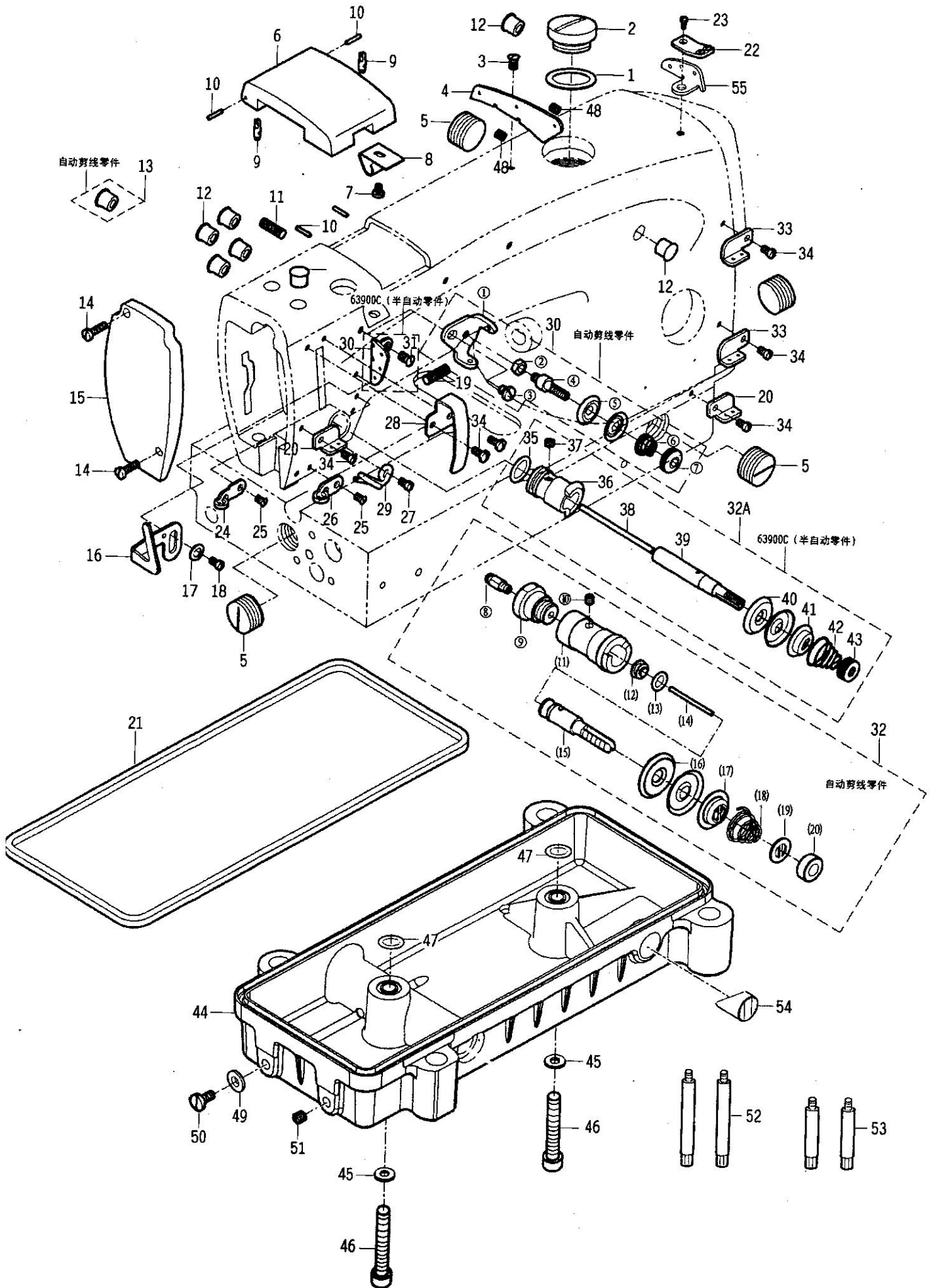

罩盖及夹线部件.MISCELLANEOUS COVERS AND NEEDLE TENSION PARTS

序号	图号	零部件名称	NAME OF PARTS	数量
1	9B-1	油封垫圈	Gasket	1
2	9B-2	螺塞 111/128-20×8	Plug Screw, for oil filler hole 111/128-20×8	1
3	9B-31	螺钉 23/128-40×8	Screw 23/128-40×8	1
4	9B-4a	过线板	Frame Thread Eyelet	1
5	9B-5a	螺塞 51/64-24×10.8	Plug Screw 51/64-24×10.8	4
6	9B-6	顶盖	Top Cover	1
7	9B-7a	螺钉 37/256-40×4.5	Screw 37/256-40×4.5	1
8	9B-8	锁片	Spring Clip	1
9	9B-9	顶盖铰链	Top Cover Hinge	2
10	9B-10	顶盖铰链销 2.1×10	Top Cover Hinge Pin 2.1×10	4
11	9B-25	紧定螺钉 27/128-32×16	Set Screw 27/128-32×16	1
12	9B-12a	胶塞	Plug, plastic	8
13	9-4J-41	胶塞 (自动剪线零件)	Plug, plastic	1
14	9B-14a	夹紧螺钉 M5×11	Pinch Screw M5×11	2
15	9B-15	面盖	Head Cover	1
16	9B-17	拦线钩	Thread Pull-up Bracket	1
17	C-71-4	垫圈	Washer	1
18	4D-37	螺钉	Screw	1
19	9B-25	紧定螺钉 27/128-32×16	Set Screw, for tension assembly 27/128-32×16	1
20	9-3B-20	过线板	Thread Guide Plate	1
21	9B-57	密封垫	Gasket	1
22	9-3B-22	过线板	Thread Guide Plate	1
23	9-3B-23	螺钉 11/64-40×8	Screw 11/64-40×8	1
24	9B-27	过线钩	Thread Guide	1
25	9B-21	螺钉	Screw	2
26	9B-18	上过线钩	Upper Needle Thread Eyelet	1
27	4D-37	螺钉 9/64-40	Screw 9/64-40	1
28	9-3B-28	挑线杆护罩	Take-up Lever Shield	1
29	9E-70	导线板	Thread Guide Plate	1
30	9B-30	过线板	Frame Thread Eyelet	1
①	9-4J-33	夹线座	Tension Holder	1
②	3F-14	螺母 11/64-40	Nut 11/64-40	1
③	9E-17	一字槽螺钉 23/128-40	Screw 23/128-40	1
④	33N-20	绕线器夹线螺杆	Tension Bolt	1
⑤	33N-19	夹线板	Tension Plate	1
⑥	33N-18	夹线簧	Tension Spring	1
⑦	33N-17	绕线器螺母	Tension Nut	1
31	9B-31	螺钉 23/128-40×8	Screw 23/128-40×8	1

32~55请见下页

罩盖及夹线部件

MISCELLANEOUS COVERS AND NEEDLE TENSION PARTS

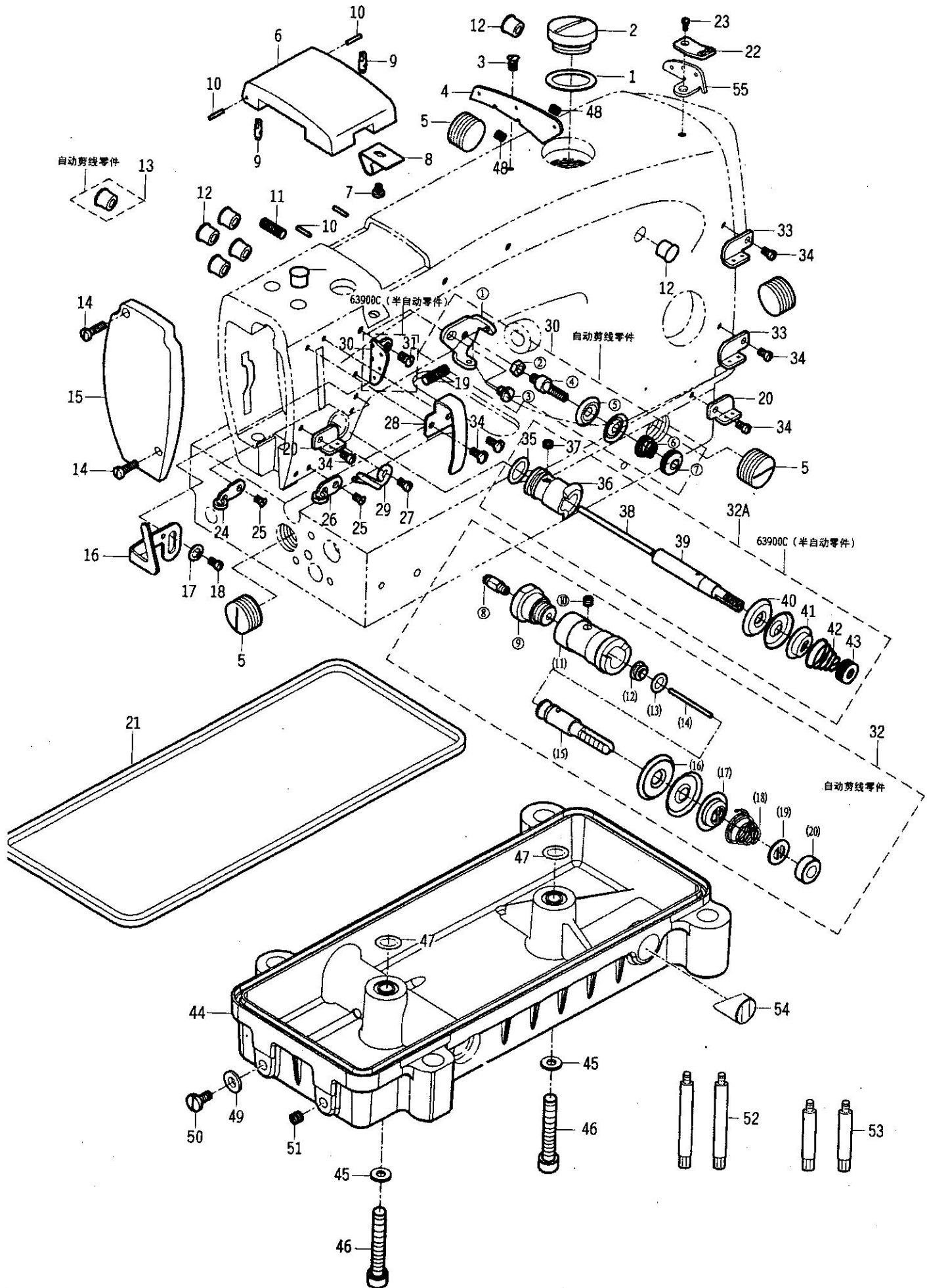

罩盖及夹线部件 (续) . MISCELLANEOUS COVERS AND NEEDLE TENSION PARTS (CONT)

序号	图号	零部件名称	NAME OF PARTS	数量
1~31请见上页				
32	9B-36	夹线组件(自动剪线)	Thread Tension Assembly	1
⑧	9-4K-20	小直通接头SPC4-M5 C	Thread Joint SPC4-M5 C	1
⑨	9-4J-23	螺塞	Plug Screw	1
⑩	B-40	紧定螺钉 M4 × 4	Set Screw M4 × 4	1
(11)	9-4J-28	夹线座	Tension Holder	1
(12)	9-4J-29-1	活塞环	Piston Collar	1
(13)	9-4J-29-2	密封圈	Seal Ring	1
(14)	9-4J-30	松线销	Thread Tension Releasing Pin	1
(15)	9-4J-31	夹线螺杆	Tension Bolt	1
(16)	9B-43	夹线板	Tension Disc	2
(17)	9B-44	松线垫圈	Tension Release Washer	1
(18)	10D-28	夹线簧	Tension Spring	1
(19)	9B-72	防转垫片	Locking Washer	1
(20)	9B-46a	夹线螺母 33/128-32	Tension Nut 33/128-32	1
32A	9B-32A	夹线组件(63900C半自动剪线)	Thread Tension Assembly	1
33	9-3B-33	过线板	Thread Guide Plate	2
34	10C-27	螺钉 9/64-40 × 5.8	Screw 9/64-40 × 5.8	6
35	9B-37a	密封O形圈	Quad Ring	1
36	9B-38a	夹线座	Tension Post Socket	1
37	9B-39	紧定螺钉 27/128-32 × 4.4	Set Screw 27/128-32 × 4.4	1
38	9B-40a	松线销	Tension Release Pin	1
39	9B-41	夹线螺杆	Tension Post	1
40	9B-43	夹线板	Tension Disc	2
41	9B-44	松线垫圈	Tension Release Washer	1
42	10D-28	夹线簧	Tension Spring	1
43	9B-46a	夹线螺母 33/128-32	Tension Nut 33/128-32	1
44	9B-55C	储油底盘	Oil Reservoir Bottom Cover	1
45	9B-54	垫圈	Washer	2
46	9B-53A	内六角螺钉 5/16-24 × 45	Screw 5/16-24 × 45	2
47	9B-58	密封O形圈	Quad Ring	2
48	2F-19	螺钉 11/64-40 × 6	Screw 11/64-40 × 6	2
49	9B-73	密封垫圈	Quad Washer	1
50	3G-5	螺塞 5/16x24	Screw 5/16x24	1
51	10G-19a	堵头螺塞 5/16-24x9	Screw 5/16-24x9	1
52	9B-75	左支柱	Left a Mainstay	2
53	9B-76	右支柱	Right a Mainstay	2
54	17B1-25-2	油镜	Oil Lens	1
55	9B-30	过线板(自动剪线)	Frame Thread Eyelet	1

传动轴. 针杆及压脚提升机构

DRIVE SHAFTS .NEEDLE BAR .FOOT LIFTER MECHANISM

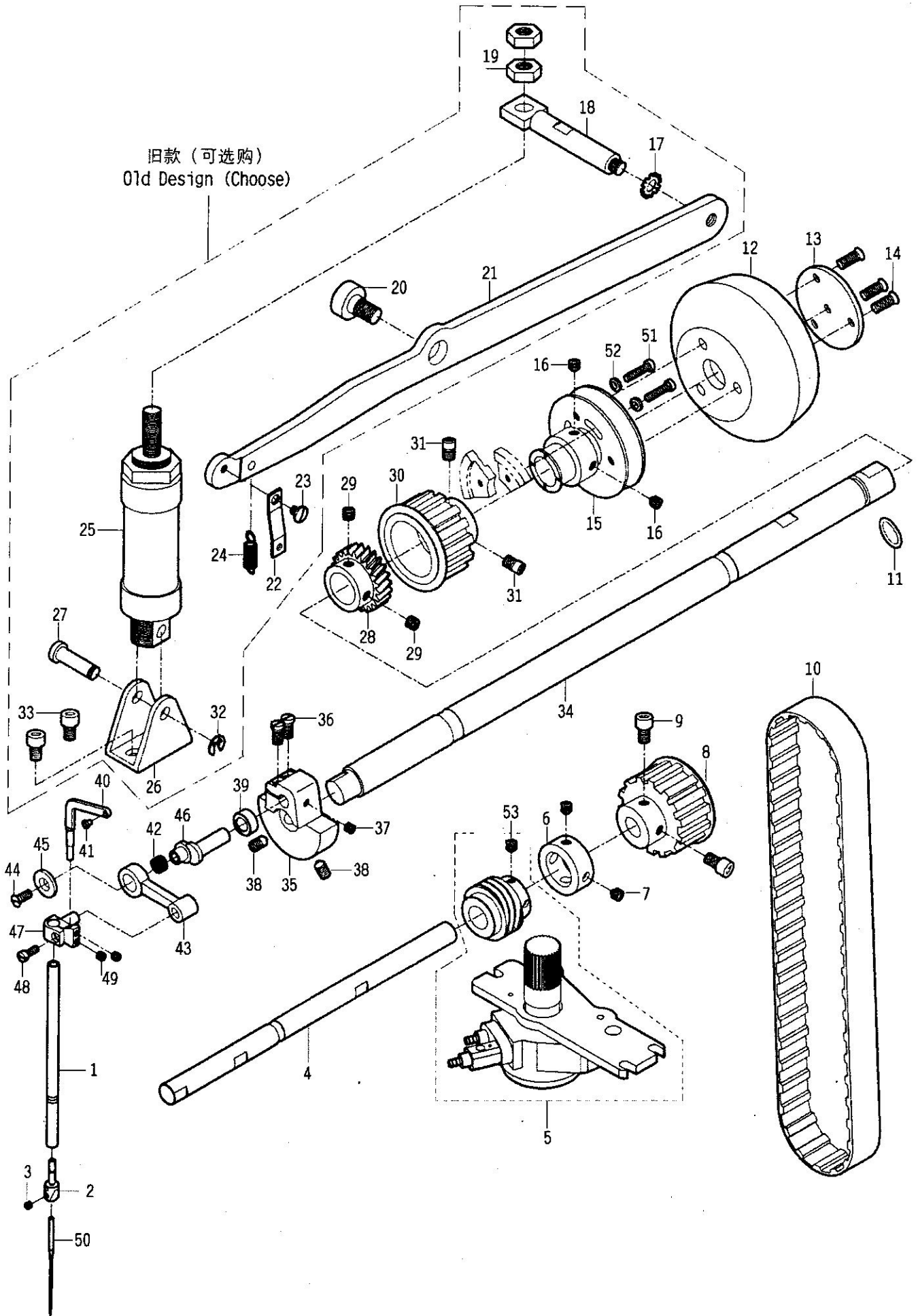

传动轴.针杆及压脚提升机构.DRIVE SHAFTS.NEEDLE BAR.FOOT LIFTER MECHANISM

序号	图号	零部件名称	NAME OF PARTS	数量
1	9-3C-1	针杆	Needle Bar	1
2	9-3C-2	针夹	Needle Holder	1
3	C-68	紧定螺钉 9/64-40 × 3.5	Set Screw 9/64-40 × 3.5	1
4	9-3C-4	传动轴	Driving Shaft	1
5	9C-5A-4	回油泵组件	Oil Return Pump	1
6	3G-6	轴环	Shaft Collar	1
7	8B-20	紧定螺钉	Set Screw	2
8	9C-8	下同步带轮	Driving Shaft Sprocket	1
9	9C-9a	螺钉 M6 × 10	Screw M6 × 10	2
10	9C-10	同步带	Feed Driving Belt	1
11	9C-11a	密封O形圈	Quad Ring	1
12	9C-12a	手轮	Handwheel	1
13	9C-13	皮带轮压片	Hub Washer	1
14	9C-14	皮带轮压片螺钉 55/256-32 × 15	Screw 55/256-32 × 15	3
15	9-4I-22	定针皮带轮	Pulley	1
16	A-58	紧定螺钉 M6 × 6	Set Screw M6 × 6	2
17	9C-17	外齿弹性垫圈	Lock Washer	1
18	9-4I-8	压脚提升长螺栓	Lifter Lever Extension Stud	1
19	9-4I-9	螺母 M10-1.25	Nut M10-1.25	2
20	9C-20	销轴螺钉 D=11.11 H=4.546	Hinge Screw D=11.11 H=4.546	1
21	9-3C-21	压脚提升杆	Lifter Lever	1
22	9C-22	连接板	Lifter Lever Link	1
23	9C-23	销轴螺钉 D=5.556 H=1.65	Hinge Screw D=5.556 H=1.65	1
24	9C-24a	压脚提升弹簧	Lifter Lever Spring	1
25	9-4I-14	气缸 MAL-CA 25 × 25	Cylinder MAL-CA 25 × 25	1
26	9-4I-10	气缸固定板	Cylinder Bracket	1
27	9-4I-11	销轴	Stud	1
28	9C-28	主轴传动齿轮	Main Shaft Reduction Drive Gear	1
29	9C-29	紧定螺钉 1/4-28 × 5	Set Screw 1/4-28 × 5	2
30	9C-30	上同步带轮	Main Shaft Driving Sprocket	1
31	13C-48	紧定螺钉 M3 × 7	Looper Set Screw M3 × 7	2
32	12G-12	挡圈 6	Collar 6	1
33	10F-28	螺钉 M6 × 10	Screw M6 × 10	2
34	9C-34a	主轴	Main Shaft	1
35	9C-35a	挑线凸轮	Counterweight	1
36	9C-36	螺钉 55/256-32 × 10.3	Screw 55/256-32 × 10.3	2
37	9E-13	紧定螺钉 23/128-40 × 4	Set Screw 23/128-40 × 4	1
38	B-17	紧定螺钉 M6 × 10	Set Screw M6 × 10	2
39	9-3C-39	隔圈	Sleeve	1
40	9-3C-40	挑线杆	Take-Up Lever	1
41	9C-41	过线套	Take-Up Lever Eyelet	1
42	9C-42a	滚针	Needle Bearing	1
43	9C-43	针杆连杆	Needle Bar Link	1
44	9C-44	螺钉 47/256-32(左) × 10.3	Screw 47/256-32(L) × 10.3	1
45	9C-45	止推垫圈	Thrust Washer	1
46	9-3C-46	挑线杆偏心轴	Take-Up Lever Crank Pin	1
47	9-3C-47	针杆接头	Needle Bar Connection	1
48	9C-51a	螺钉 9/64-40 × 8.5	Screw 9/64-40 × 8.5	1
49	JGA-44	紧定螺钉 M3 × 3	Set Screw M3 × 3	2
50	13A-33	机针 DV × 57	Needle DV × 57	1
51	9-3C-51	螺钉 M4 × 16	Screw M4 × 16	2
52	C-71-4	垫圈 4.4 × 7.5 × 1.5	Washer 4.4 × 7.5 × 1.5	2
53	C-22-3	紧定螺钉 M5 × 6	Set Screw M5 × 6	1

针送料操纵部件
NEEDLE FEED DRIVING PARTS

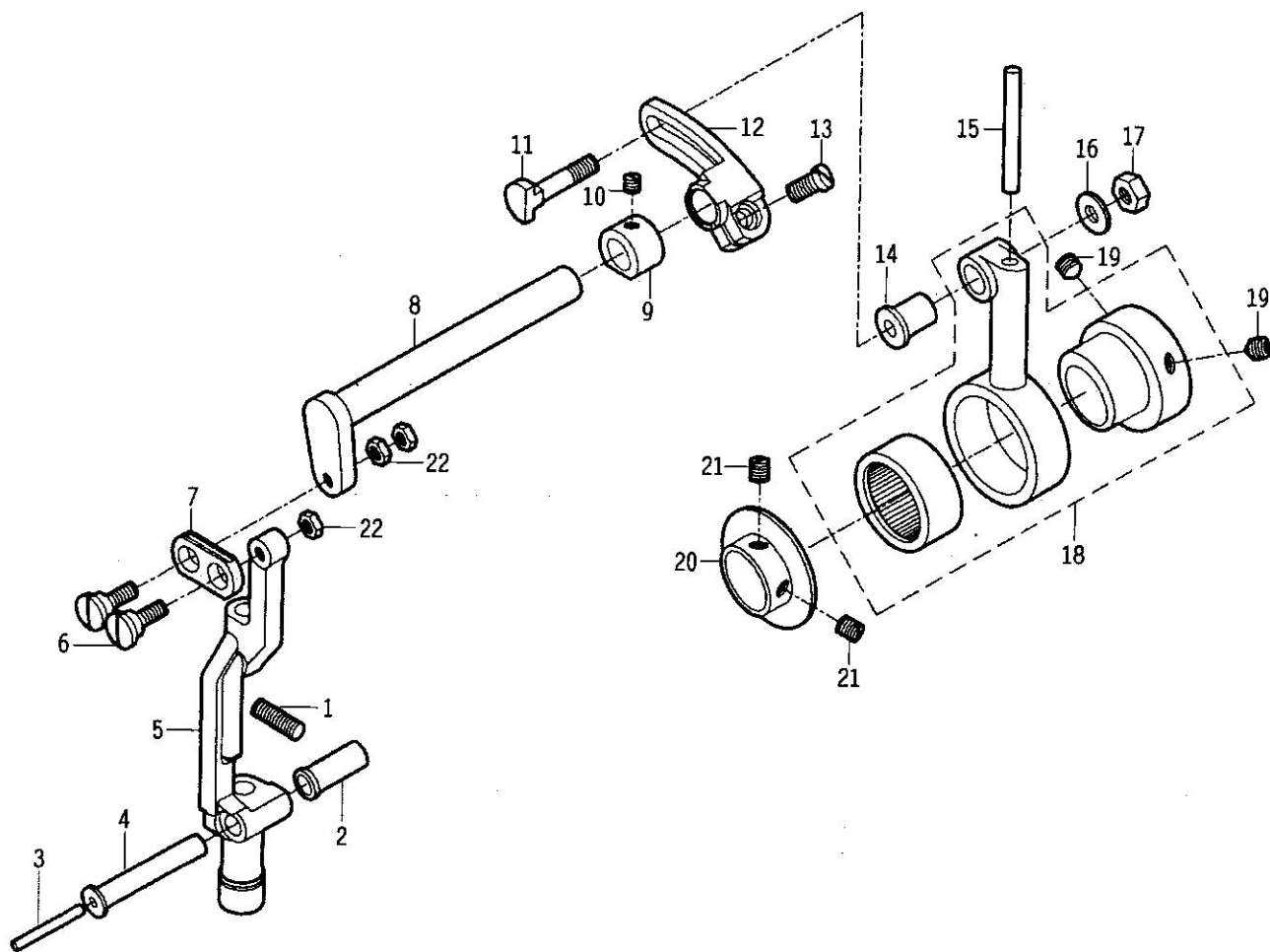

针送料操纵部件.NEEDLE FEED DRIVING PARTS

序号	图号	零部件名称	NAME OF PARTS	数量
1	9B-25	紧定螺钉 27/128-32 × 16	Set Screw, for tension assembly 27/128-32 × 16	1
2	9D-2a	针杆架调整套	Needle Bar Frame Pivot Adjustable Bushing	1
3	9D-3	油绳	Oil Wick	1
4	9D-4	针杆架支轴	Needle Bar Frame Pivot Stud	1
5	9-3D-5	针杆支架	Needle Bar Frame	1
6	9D-6	销轴螺钉 D=8 H=3.8	Hinge Screw D=8 H=3.8	1
7	9D-7	连接板	Needle Bar Frame Rock Shaft Connecting Link	1
8	9D-8	摆针轴	Needle Bar Frame Rock Shaft	1
9	9D-9	挡圈	Collar	1
10	9E-13	紧定螺钉 23/128-40 × 4	Set Screw 23/128-40 × 4	1
11	9D-11	连接螺栓 27/128-32	Connecting Stud 27/128-32	1
12	9D-12	摆针轴传动杆	Needle Bar Frame Rock Shaft Driving Lever	1
13	9C-36	螺钉 55/256-32 × 10.3	Screw 55/256-32 × 10.3	1
14	9D-14	轴套	Bushing	1
15	9D-15	油绳	Oil Wick	1
16	9D-16	垫圈 5.6 × 12.7 × 1.3	Washer 5.6 × 12.7 × 1.3	1
17	9D-17	螺母 27/128-32	Nut 27/128-32	1
18	9D-18a	连杆组件	Needle Feed Drive Eccentric and Connecting Rod Assembly	1
19	A-58	紧定螺钉 M6 × 6	Set Screw M6 × 6	2
20	9D-20	滚针轴承止动圈	Needle Bearing Retaining Collar	1
21	9D-21	紧定螺钉 55/256-32 × 6	Set Screw 55/256-32 × 6	2
22	9D-22	螺母 23/128-40	Nut 23/128-40	3

压脚及上送料轮机构

PRESSER FEET AND TOP FEED ROLLER MECHANISM

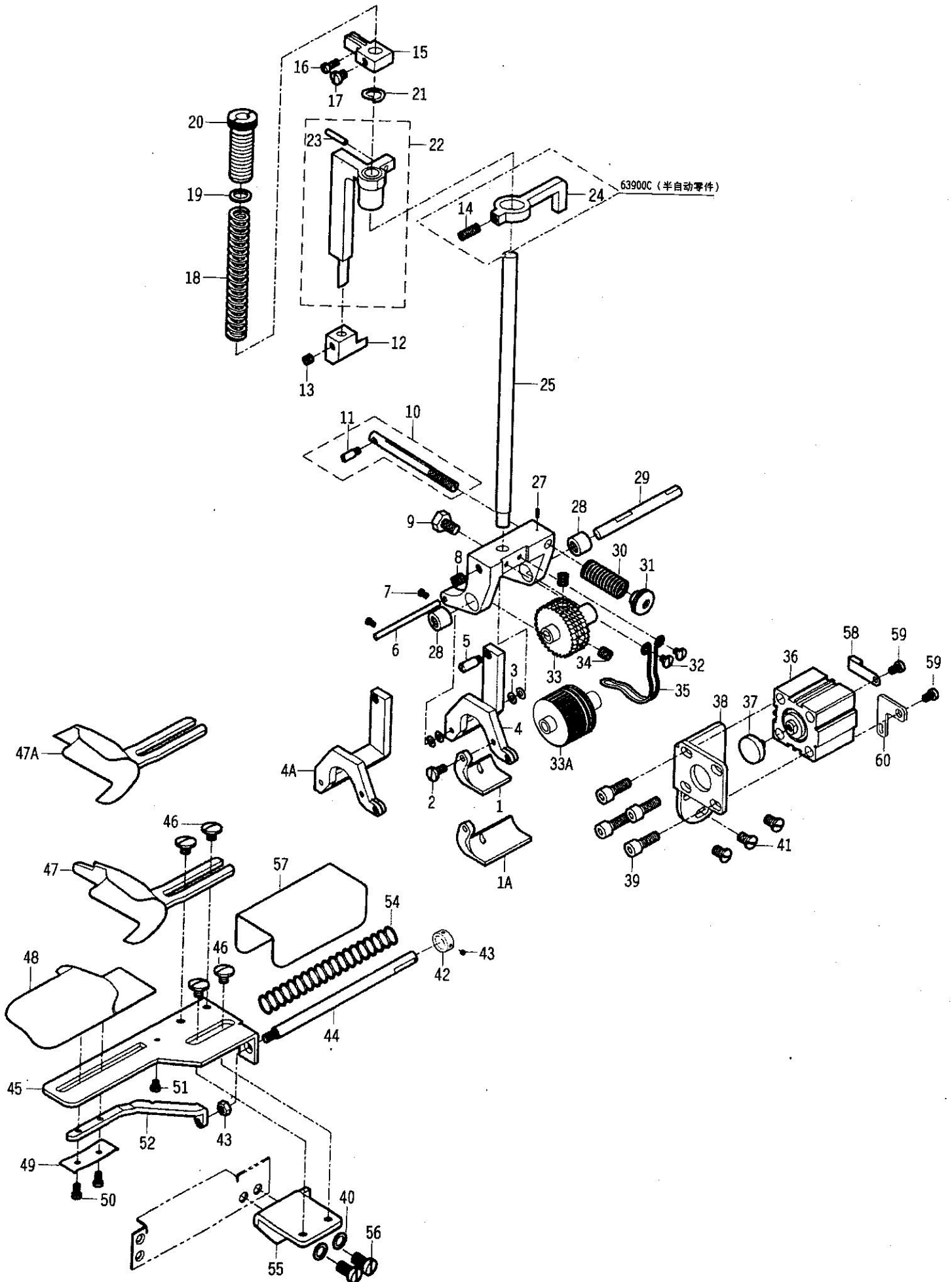

压脚及上送料轮机构.PRESSER FEET AND TOP FEED ROLLER MECHANISM

序号	图号	零部件名称	NAME OF PARTS	数量
1	9E-50Ab	压脚 1/2"	Presser Foot, for 1/2 inch hem	1
1A	9-3E-1A	压脚 3/2" (休闲)	Presser Foot, for 3/2 inch hem	1
2	9E-2	螺钉 37/256-40×7.8	Screw 37/256-40×7.8	1
3	9E-3	垫圈 3.3×6.4×0.27	Washer 3.3×6.4×0.27	1
4	9E-4	压脚板支架	Presser Foot Shank	4
4A	9E-4A	压脚板支架 (休闲)	Presser Foot Shank	1
5	9E-5	螺钉销 37/256-40	Screw Pin 37/256-40	1
6	9E-6	铰链销	Presser Foot Shank Hinge Pin	1
7	9E-7a	螺钉 23/256-56×3.8	Screw 23/256-56×3.8	1
8	9D-21	紧定螺钉 55/256-32×6	Set Screw 55/256-32×6	2
9	9E-9	螺钉 55/256-32×9	Screw 55/256-32×9	1
10	9E-10	夹线螺杆合件	Presser Foot Tension Bar	1
11	9E-11	螺钉销 1/8-44	Screw Pin 1/8-44	1
12	9E-12	压脚提升滑块	Presser Foot Lifter Block	1
13	9E-13	紧定螺钉 23/128-40×4	Set Screw 23/128-40×4	1
14	9E-14	螺钉 23/128-40×12	Screw 23/128-40×12	1
15	9E-15a	压杆导架	Presser Bar Guide	1
16	2D-19	螺钉 1/8-44×7.5	Screw 1/8-44×7.5	1
17	9E-17	螺钉 23/128-40×5	Screw 23/128-40×5	1
18	9E-18a	压杆弹簧	Roller Presser Spring	1
19	9E-19	垫圈 8.1×11.8×1.1	Presser Spring Washer 8.1×11.8×1.1	1
20	9E-20a	压簧调节套	Presser Spring Regulator and Bushing	1
21	9E-21	弹簧垫圈	Presser Bar Spring Washer	1
22	9E-22	提升杆合件	Presser Bar Connection	1
23	9E-23	销 4×12.8	Roll Pin 4×12.8	1
24	9E-24a	松线杠杆板	Tension Release Cam	1
25	9E-25a	压杆	Presser Bar	1
26	9E-26a	上送料轮支架	Top Roller Bracket	1
27	9E-27	销 1×4.8	Pin 1×4.8	1
28	9E-28	滚针轴承	Needle Bearing	1
29	9E-29	上送料轮支轴	Top Feed Roller Shaft	2
30	9E-30	夹线调节弹簧	Presser Foot Tension Regulating Spring	1
31	9E-31	调节螺母 7/32-32	Presser Foot Tension Regulating Nut 7/32-32	1
32	9E-32a	螺钉 1/8-44×3.8	Screw 1/8-44×3.8	1
33	9E-33	上送料轮	Top feed Roller	2
33A	9E-33D	上送料轮 (休闲)	Top feed Roller	1
34	9D-21	紧定螺钉 55/256-32×6	Set Screw 55/256-32×6	1
35	9E-35	(上送料轮)卸料器	Upper Roller Stripper	2
36	9-4I-1	气缸 SDA 20×15	Cylinder SDA 20×15	1
37	9-4I-4	防震胶螺钉 M4×6	Rubber Screw M4×6	1
38	9-3E-38	气缸支架	Cylinder Support bracket	1
39	7B-23	螺钉 M5×14	Screw M5×14	1
40	8B-24	垫圈 5.6×9.5×0.8	Washer 5.6×9.5×0.8	4
41	7A-4	螺钉 M5×8	Screw M5×8	2
42	9E-54	挡圈	Collar	3
43	9E-55	螺钉	Screw	1
44	9-3E-44	卷边器操纵杆	Hemmer Operating Rod	1
45	9E-57	卷边器底板	Hemmer Base	1
46	9E-58	螺钉 47/256-40×5.8	Screw 47/256-40×5.8	1
47	9-4J-39	右卷筒	Hemmer Scroll, right	4
47A	9-3E-59A	右卷筒 (休闲)	Hemmer Scroll, right	1
48	9E-60a	左卷筒	Hemmer Scroll, left	1
49	9E-61	卷筒滑动板簧	Hemmer Scroll Slide Spring	1
50	2C-15	螺钉 1/8-44×5.9	Screw 1/8-44×5.9	1
51	8F-10	螺钉 7/64-48×3.8	Stop Screw 7/64-48×3.8	2
52	9E-64a	卷筒导向板	Hemmer Scroll Slide	1
53	3F-14	螺母 11/64-40	Nut 11/64-40	1
54	9E-66a	卷筒复位弹簧	Hemmer Operating Rod Spring	1
55	9-3E-55	卷边器支架	Hemmer Mounting Bracket	1
56	9-3E-56	螺钉 55/256-32×9.7	Screw 55/256-32×9.7	1
57	9-3J-61	防护罩	Safety Guard	2
58	9-3J-60	气管支架	Pipe Fixation	1
59	7A-4	螺钉 M5×8	Screw M5×8	1
60	9-3J-66	过线板	Frame Thread Eyelet	1

弯针及松线部件

LOOPER AND TENSION RELEASE PARTS

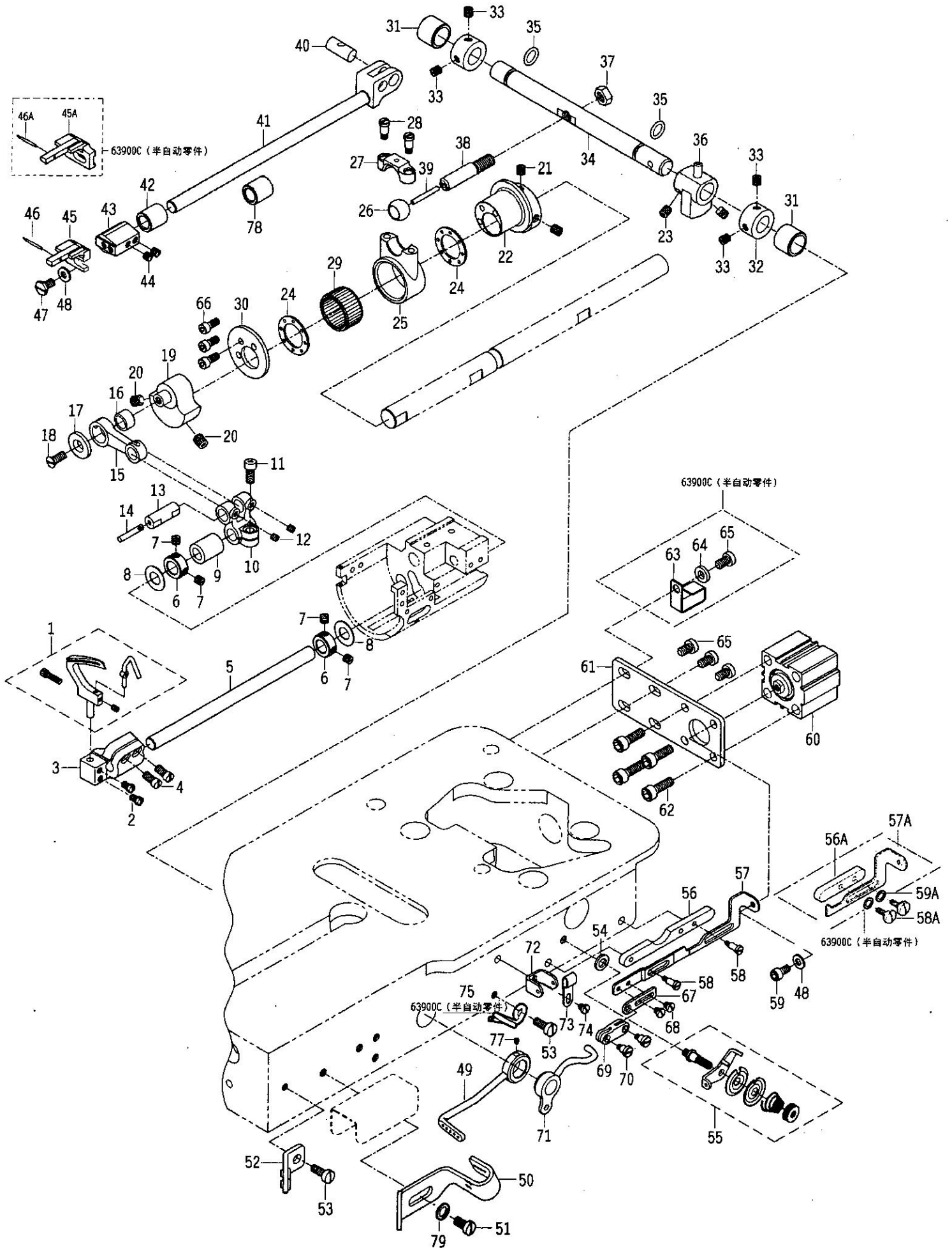

弯针及松线部件.LOOPER AND TENSION RELEASE PARTS

序号	图号	零部件名称	NAME OF PARTS	数量
1	13C-49	弯针与护针板组件	Looper and Needle Guard complete	1
2	9-3F-2	弯针紧定螺钉 M4X6	Looper Set Screw M4X6	2
3	9-3F-3	弯针夹	Looper Holder	1
4	33J-25	螺钉 11/64-40 × 8	Screw 11/64-40 × 8	2
5	9-3F-5	弯针轴	Looper Carrier Shaft	1
6	9F-21	挡圈	Thrust Collar	2
7	9E-13	紧定螺钉 23/128-40 × 4	Set Screw 23/128-40 × 4	4
8	9C-48	垫圈 8.2 × 16 × 0.6	Washer 8.2 × 16 × 0.6	2
9	9A-56a	弯针轴右轴套	Looper Carrier Shaft Bushing, right	1
10	9-3F-10	弯针曲柄	Looper Crank	1
11	12P-3	螺钉 11/64-40 × 10	Screw 11/64-40 × 10	1
12	C-68	紧定螺钉 9/64-40 × 3.5	Set Screw 9/64-40 × 3.5	2
13	9-3F-13	铰链销 7.94	Hinge Pin 7.94	1
14	13B-6	油绳	Oil Packing (wick)	1
15	9-3F-15	弯针连杆	Looper Connecting link	1
16	9-3F-16	轴套	Bushing	1
17	9C-45	止推垫圈	Thrust Washer	1
18	9C-44	螺钉 47/256-32(左) × 10.3	Screw 47/256-32(L) × 10.3	1
19	9-3F-19	凸轮	Cam	1
20	12B-32	紧定螺钉 15/64-28 × 6	Set Screw 15/64-28 × 6	1
21	C-22-3	紧定螺钉 M5 × 6	Set Screw M5 × 6	2
22	9-3F-22	叉针偏心轮	Spreader Driving Eccentric	1
23	C-22-3	紧定螺钉 M5 × 6	Set Screw M5 × 6	2
24	9-3F-24	止推垫圈	Thrust Washer	2
25	9-3F-25	叉针连杆	Spreader Driving Connection	1
26	13D-30	球体	Ball Roller	1
27	13D-31	叉针连杆盖	Spreader Driving Connection Cap	1
28	13D-32	螺钉 9/64-40	Screw 9/64-40	2
29	9-3F-29	滚针轴承	Needle Bearing	1
30	9-3F-30	止推挡圈	Throat Plate	1
31	9-3F-31	轴套	Bushing	2
32	13C-3	挡圈	Collar	2
33	8D-29	紧定螺钉 3/16-32 × 4.8	Set Screw 3/16-32 × 4.8	4
34	9-3F-34	叉针轴	Spreader Driving Rock Shaft	1
35	9-3F-35	O形密封圈 8	"O" Ring 8	2
36	9-3F-36	叉针曲柄	Spreader Driving Crank	1
37	2D-15	螺母 9/32-28	Nut 9/32-28	1
38	9-3F-38	叉针轴螺栓 9/32-28	Spreader Driving Rock Shaft Stud 9/32-28	1
39	13D-13	油绳	Oil Packing (wick)	1
40	13D-1	叉针销	Spreader Driving Pin	1

41~79请见下页

弯针及松线部件

LOOPER AND TENSION RELEASE PARTS

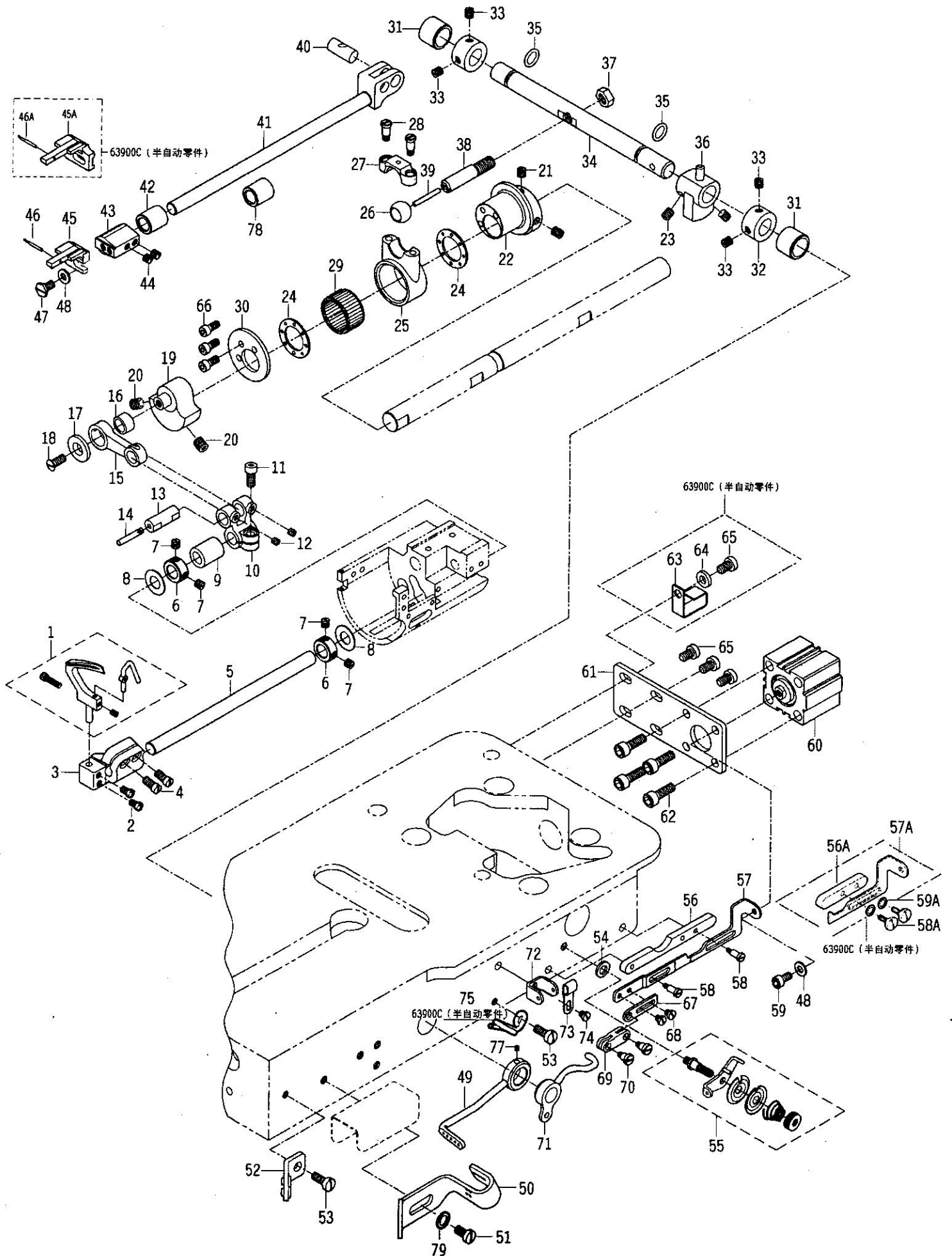

弯针及松线部件 (续) . LOOPER AND TENSION RELEASE PARTS (CONT)

序号	图号	零部件名称	NAME OF PARTS	数量
1~40请见上页				
41	9-3F-41	叉针杆	Spreader Bar	1
42	9-3F-42	叉针杆轴套	Spreader Bar Bushing	1
43	13D-5	叉针夹	Spreader Holder	1
44	3C-14	紧定螺钉 11/64-40 × 4.5	Set Screw 11/64-40 × 4.5	2
45	9-3J-45	叉针 (63900CTR全自动零件)	Spreader	1
45A	9-3F-45	叉针 (63900C半全自动零件)	Spreader	1
46	9-3J-46	叉针尖 (63900CTR全自动零件)	Spreader Point	1
46A	13D-7	叉针尖 (63900C半全自动零件)	Spreader Point	1
47	13D-8	叉针螺钉 11/64-40 × 7.5	Spreader Screw 11/64-40 × 7.5	1
48	C-51	垫圈 4.5 × 9 × 1	Washer 4.5 × 9 × 1	2
49	9-3F-49	弯针挑线杆组件	Looper Thread take-up Rod Component	1
50	9-3F-50	弯针导线板	Looper Thread Guide	1
51	13F-29	螺钉 M5 × 10	Screw M5 × 10	1
52	9-3F-52	过线板组件	Thread Guide Plate complete	1
53	13A-19-8	螺钉 11/64-40 × 4	Screw 11/64-40 × 4	1
54	8B-24	垫圈 5.6 × 9.8 × 0.8	Washer 5.6 × 9.8 × 0.8	2
55	13E-56	弯针夹线器组件	Looper Thread Tension complete	1
56	9-3J-56	松线支板 (自动剪线零件)	Tension Releasing Support Plate	1
56A	9-3F-56	松线支板 (63900C半自动零件)	Tension Releasing Support Plate	1
57	9-3J-57	松线插板 (自动剪线零件)	Tension Releasing Plate	1
57A	9-3F-57	松线插板 (63900C半自动零件)	Tension Releasing Plate	1
58	10A-9	螺钉 9/64-40	Screw 9/64-40	2
58A	9-3F-58	螺钉 9/64-40	Screw 9/64-40	2
59	14C-37	螺钉 M4 × 8	Screw M4 × 8	1
59A	8B-24	垫圈 5.6 × 9.8 × 0.8	Washer 5.6 × 9.8 × 0.8	2
60	9-3F-60	松线气缸 SDA 20 × 10	Tension Releasing Cylinder SDA 20 × 10	1
61	9-3F-61	气缸支承板	Cylinder Support Plate	1
62	C-18	螺钉 M5 × 16	Screw M5 × 16	4
63	9-3F-63	气管固定架	Pipe Fixation	1
64	7C-61	垫圈 5.1 × 10 × 2	Washer 5.1 × 10 × 2	1
65	7F-2	螺钉 M5 × 8.2	Screw M5 × 8.2	4
66	9-3F-66	螺钉 M3X6	Screw M3 × 6	3
67	9-3J-51	调节板	Adjustment Board	1
68	7C-42	螺钉 M4 × 4	Screw M4 × 4	2
69	9-3J-50	连接杆	Connecting Link	1
70	9-3J-53	螺钉 M4	Screw M4	2
71	9-3J-49	挑线杆组件	Take-up Rod Component	1
72	9-3J-52-1	挑线导向板	Guide Bracket	1
73	9-3J-54	气管支架	Cylinder Bracket	1
74	10-2J-37	螺钉 11/64-40 × 8	Screw 11/64-40 × 8	1
75	9E-70	导线板	Thread Guide Plate	1
76	7C-61	垫圈	Washer	1
77	8D-29	螺钉 3/16-32	Screw 3/16-32	2
78	9-3F-78	密封套	Airproof Bushing	1
79	10A-6	垫圈	Washer	1

送料轮操纵部件
FEED ROLLER DRIVING PARTS

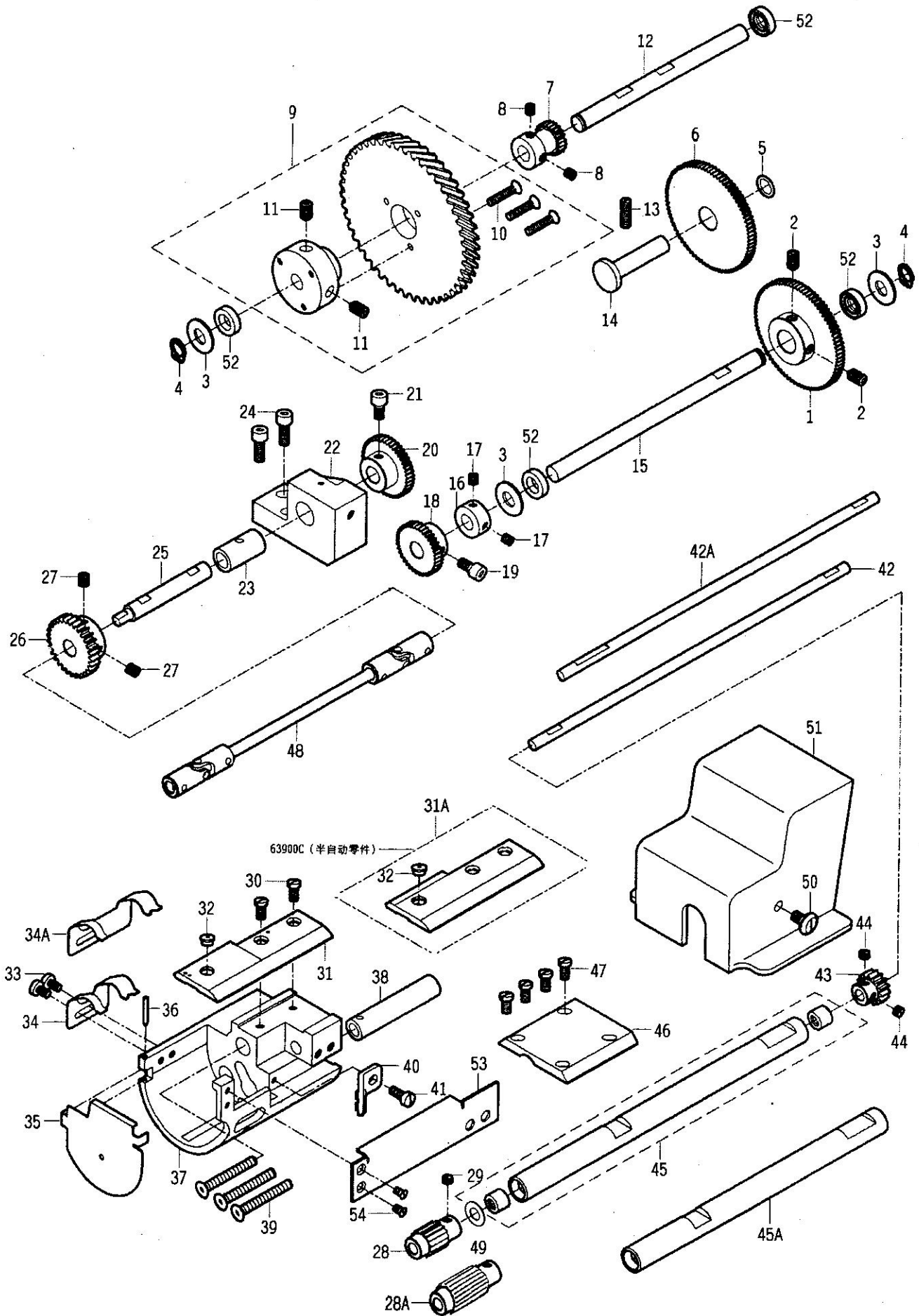

送料轮操纵部件.FEED ROLLER DRIVING PARTS

序号	图号	零部件名称	NAME OF PARTS	数量
1	9G-1b	下减速齿轮	Lower Reduction Gear	
2	B-17	紧定螺钉 M6 × 10	Set Screw M6 × 10	1
3	9G-3a	垫圈 9.6 × 20 × 1.3	Washer 9.6 × 20 × 1.3	2
4	9G-4a	轴用弹性挡圈	Truarc Ring	3
5	9G-5	O形圈	O Ring	2
6	9G-6	中间减速齿轮	Middle Reduction Gear	1
7	9G-7a	上减速驱动齿轮	Upper Reduction Drive Gear	1
8	8D-29	紧定螺钉 3/16-32 × 4.8	Set Screw 3/16-32 × 4.8	1
9	9G-9	齿轮组件	Upper Reduction Driven Gear	2
10	9G-10a	螺钉 M4 × 20	Screw M4 × 20	1
11	B-17	紧定螺钉 M6 × 10	Set Screw M6 × 10	3
12	9G-12	上减速齿轮轴	Upper Reduction Gear Shaft	2
13	9B-25	紧定螺钉 27/128-32 × 16	Set Screw 27/128-32 × 16	1
14	9G-14	中间减速齿轮销轴	Middle Reduction Gear Stud	1
15	9G-15	下减速齿轮轴	Lower Reduction Gear Shaft	1
16	9G-16	挡圈	Thrust Collar	1
17	9E-55	螺钉 23/128-40 × 5.5	Screw 23/128-40 × 5.5	1
18	9G-18b	面线调节齿轮	Upper Stitch Regulating Gear	2
19	9G-19a	螺钉 M5 × 10	Screw M5 × 10	1
20	9G-20b	底线调节齿轮	Lower Stitch Regulating Gear	1
21	9G-19a	螺钉 M5 × 10	Screw M5 × 10	1
22	9G-22a	支承座	Top Feed Roller Drive Shaft Bushing Housing	1
23	9G-23a	轴套	Top Feed Roller Drive Shaft Bushing	1
24	7B-23	螺钉 M5 × 14	Screw M5 × 14	1
25	9G-25	上送料轮驱动轴	Top Feed Roller Drive Shaft	2
26	9G-26a	下送料驱动齿轮	Lower Feed Roller Drive Gear	1
27	9D-21	紧定螺钉 55/256-32 × 6	Set Screw 55/256-32 × 6	1
28	9G-30	下送料轮 (用于牛仔)	Lower Feed Roller	2
28A	9G-30D	下送料轮 (用于休闲)	Lower Feed Roller	1
29	9G-31	紧定螺钉 55/256-32 × 3.5	Set Screw 55/256-32 × 3.5	1
30	9G-32	螺钉 47/256-32 × 8.7	Screw 47/256-32 × 8.7	1
31	9-3J-1-1	针板 (63900CTR全自动零件)	Throat Plate	2
31A	9-3G-31	针板 (63900C半全自动零件)	Throat Plate	1
32	9G-33A	针眼 (用于牛仔)	Needle Hole Insert	1
-	9G-33B	针眼 (用于休闲)	Needle Hole Insert	1
33	9G-36	螺钉 21/128-32 × 7	Screw 21/128-32 × 7	1
34	9-3G-34	导布板 (用于牛仔)	Lower Feed Roller Stripper	2
34A	9-3G-34A	导布板 (用于休闲)	Lower Feed Roller Stripper	1
35	9-3G-35	弯针座护盖	Looper Housing Cover	1
36	9G-39	销	Roll Pin	1
37	9-3G-37	弯针座	Looper Shaft Bushing Housing	1
38	9G-41a	弯针轴左轴套	Looper Shaft Bushing	1
39	9G-42a	沉头螺钉 M5 × 40	Screw M5 × 40	1
40	9-3F-52	过线板	Thread Guide Plate	3
41	33H-15	螺钉 11/64-40 × 8	Screw 11/64-40 × 8	1
42	9G-43	下送料轮驱动轴 (用于牛仔)	Lower Feed Roller Drive Shaft	1
42A	9G-43A	下送料轮驱动轴 (用于休闲)	Lower Feed Roller Drive Shaft	1
43	9G-44a	下送料被动齿轮	Lower Feed Roller Driven Gear	1
44	9G-31	紧定螺钉 55/256-32 × 3.5	Set Screw 55/256-32 × 3.5	1
45	9-3G-45	下送料驱动轴外套 (用于牛仔)	Lower Feed Drive Shaft Housing	2
45A	9G-46-1A	下送料驱动轴外套 (用于休闲)	Lower Feed Drive Shaft Housing	1
46	9G-47	夹紧板	Clamp Plate	1
47	9G-32	螺钉 47/256-32 × 8.7	Screw 47/256-32 × 8.7	1
48	9G-49A	铰链联轴组件	Top Feed Roller Flexible Drive Shaft	4
49	9-3G-49	垫圈	Washer	1
50	9E-69	螺钉 55/256-32 × 9.7	Screw 55/256-32 × 9.7	1
51	9G-52	齿轮盖	Feed Drive Gear Cover	1
52	9G-53	防油圈	Oil Guard	1
53	9-3G-53	盖板	Cover	4
54	9B-21	螺钉 37/256-40 × 5.7	Screw 37/256-40 × 5.7	1
				2

附件
ACCESSORIES

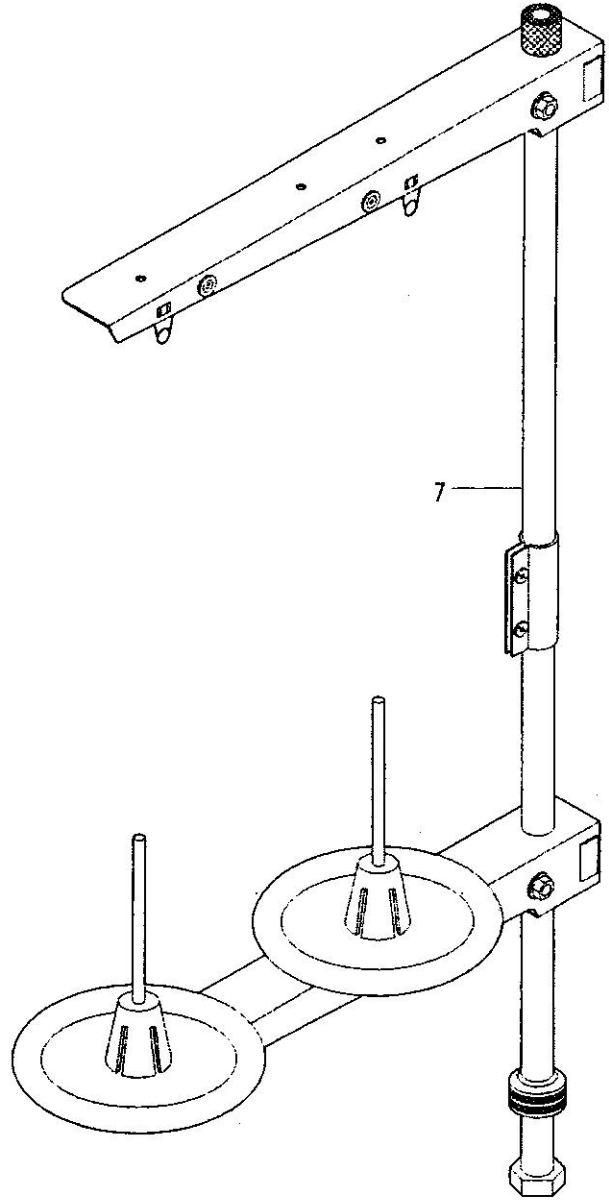
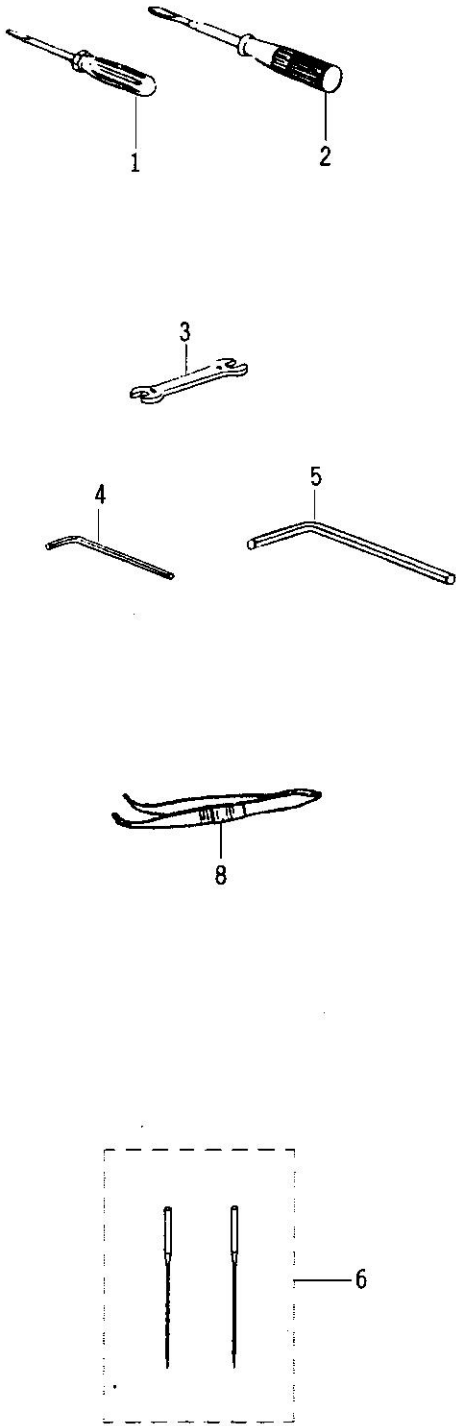

附件.ACCESSORIES

序号	图号	零部件名称	NAME OF PARTS	数量
1	3H-6	小螺批	Screw Driver (Small)	1
2	3H-7	中螺批	Screw Driver (Medium)	1
3	8H-1	小扳手 6×7	Small Wrench 5×25	1
4	D-6-1	六角匙 2.5	Hexagonal Wrench 2.5	1
5	D-4	六角匙 5	Hexagonal Wrench 5	1
6	13A-33	机针 DV×57	Needle DV×57	1
7	9H-19	线架组件	Thread Stand Assembly	2
8	D-8	镊子	Tweezers	1

电控部件

COMPONENT FOR ELECTRIC CONTROLLER

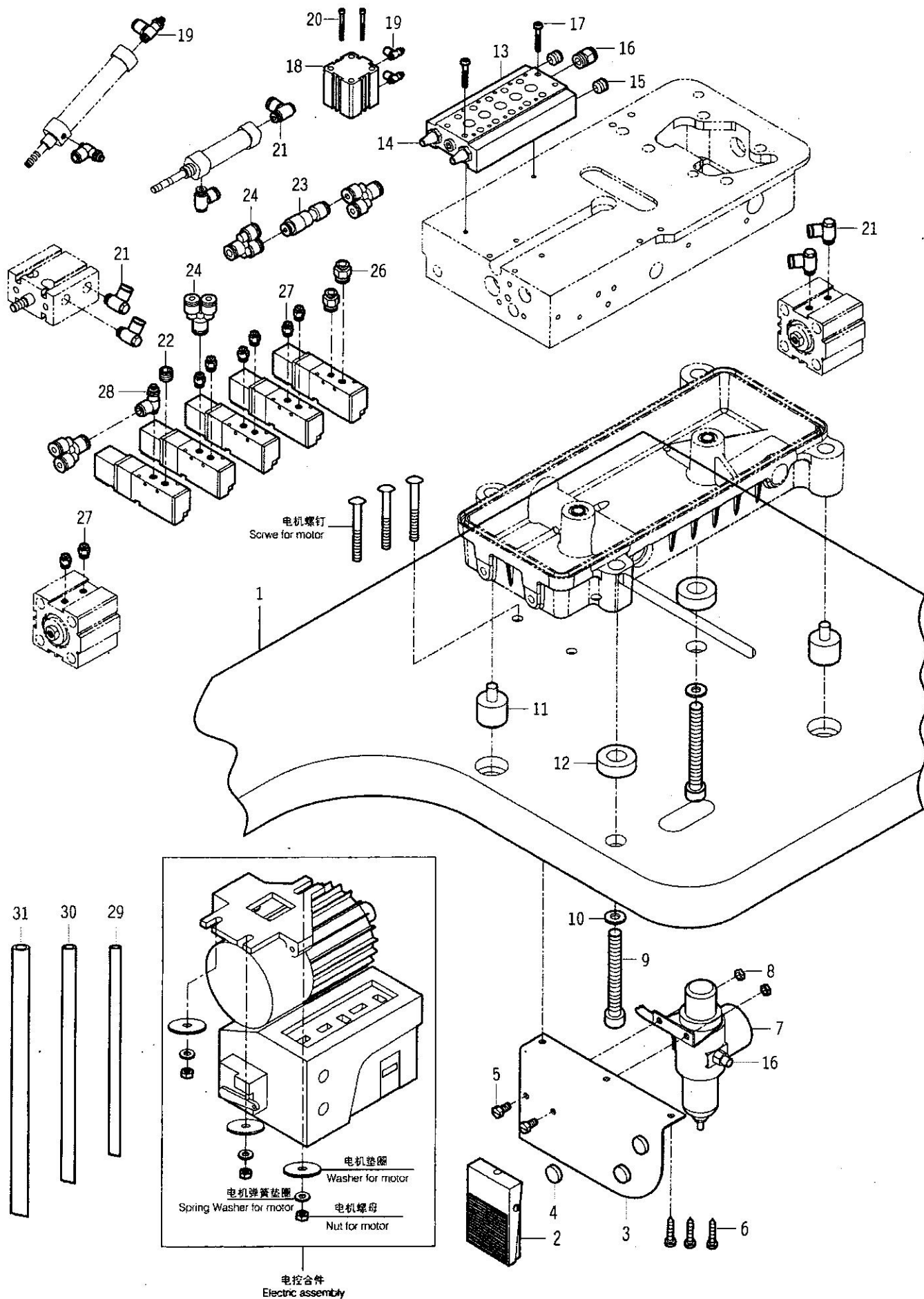

电控部件. COMPONENT FOR ELECTRIC CONTROLLER

序号	图号	零部件名称	NAME OF PARTS	数量
1	63900	63900新型台板	Table	1
2	14-1L-8	膝控开关	Knee-Switch	1
3	9-4I-18	三联件支架	Bracket	1
4	14F-23-1	磁块	Magnet	1
5	2I-19	六角头螺钉 15/64-28	Screw 15/64-28	3
6	2H-10	十字圆头自攻螺钉	Wood Screw	2
7	16L-2-9	气源处理元件 AFR-2000	Air Source Processing Element AFR-2000	3
8	10G-18	螺母 15/64-28	Nut 15/64-28	1
9	9H-42	内六角螺栓	Screw	2
10	17K-19	垫圈	Washer	2
11	9H-20	机座垫	Rubbermat For Base	2
12	9H-43	机座垫	Rubbermat For Base	2
13	9-4K-2	底座 100M-5F	Base 100M-5F	2
14	9-4K-5	消声器 ABSL-02	Silencer ABSL-02	1
15	9-4K-4	堵头 ABP-02	Plug ABP-02	2
16	9-4K-3	接头 APC8-02	Joint APC8-02	3
17	16L-2-8	十字槽圆头螺钉 M4x35	Screw M4x35	3
18	9-4K-11	抬压脚气缸 MAL25x25	Cylinder Asm MAL25x25	2
19	9-4K-10	气缸调速接头 ASL6-01B	Cylinder Adjusting Speed Joint ASL-01B	1
20	9-4J-76	螺钉 M4x35	Screw M4x35	4
21	9-4K-15	六角肘节接头 APH4-M5	Elbow Joint APH4-M5	2
22	13D-18	内六角紧定螺钉 M5x5	Screw M5x5	6
23	9-4K-20	单向节流阀	One-way Throttle Valve	1
24	9-4K-17	Y型三通接头 APY4	Y-type Joint APY4	1
25	9-4K-7	电磁阀 4V110-06-DC24V-I	Electromagnetic Valve 4V110-06-DC24V-I	8
26	9-4K-8	直通接头 APC6-01	Joint APC6-01	5
27	9-4K-13	直通接头 APC4-M5	Joint APC4-M5	2
28	9-4K-19	气缸调速接头 ASL4-M5	Cylinder Adjusting Speed Joint ASL4-M5	8
29	9-4K-14	φ4气管 (US98A040025BK)	Tube 4 (US98A040025BK)	1
30	9-4K-9	φ6气管	Tube 6	
31	9-4K-6	φ8气管	Tube 8	

自动剪线部件
COMPONENT FOR TRIMMER

半自动 (63900C) 使用9-38-23
全自动零件使用3C-14

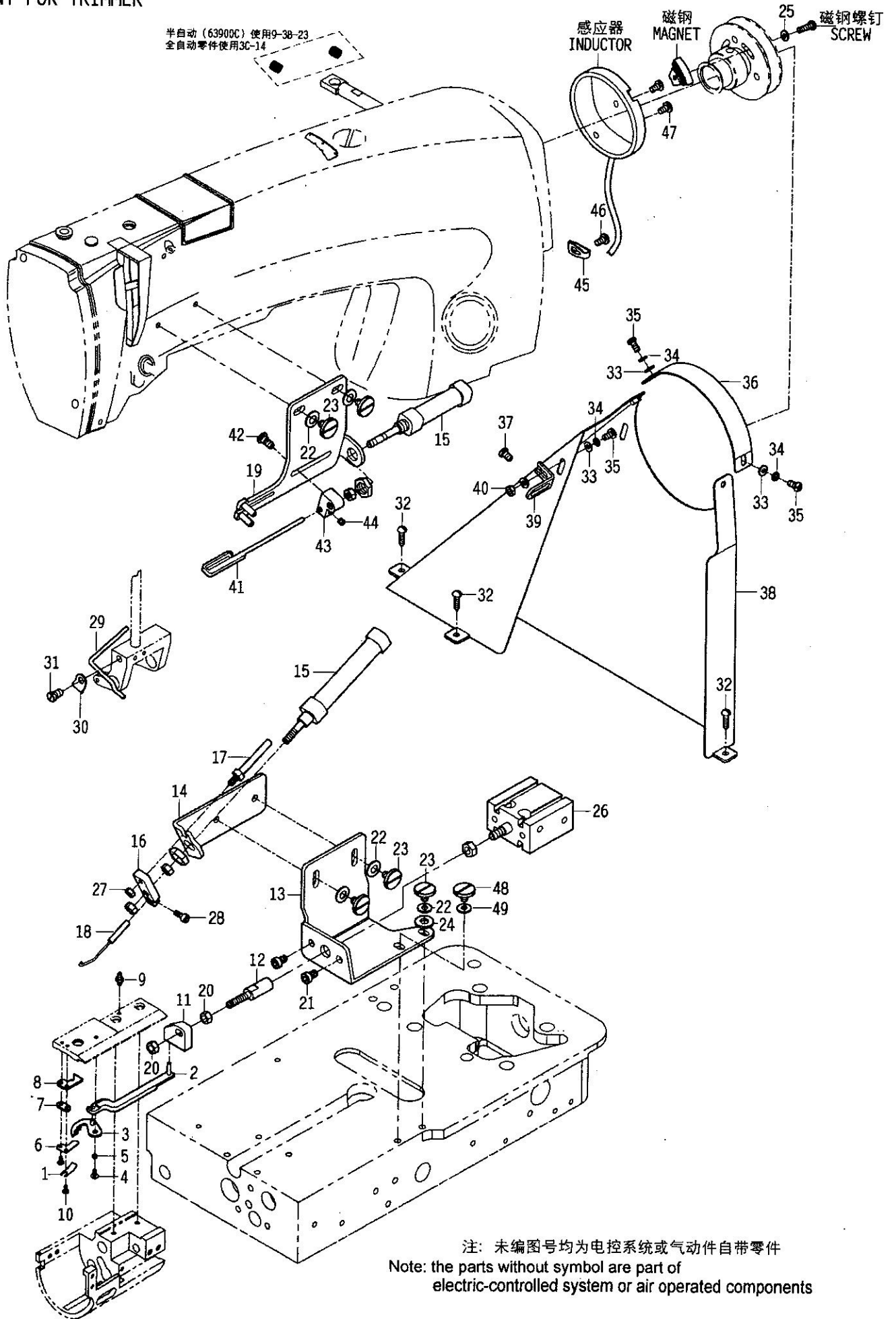

注: 未编图号均为电控系统或气动件自带零件
Note: the parts without symbol are part of electric-controlled system or air operated components

自动剪线部件.COMPONENT FOR TRIMMER

序号	图号	零部件名称	NAME OF PARTS	数量
1	9-3J-6-1	压片	Presser Spring Plate	1
2	9-3J-2	剪线拉杆组件	Thre Ad Trimmer Connecting Rod	1
3	9-3J-3	动刀组件	Movable Knife Assy	1
4	9-4J-4	螺钉 M3x5.5	Screw M3x5.5	1
5	9-3J-5	轴套	Sleeve	1
6	9-3J-6	弹簧片	Spring Leaf	1
7	9-3J-7	垫块	Block	1
8	9-3J-8	固定刀	Fixes Knife	1
9	9-4J-9	气嘴	Air Ap	1
10	9-4J-32	螺钉 3/32-56	Screw 3/32-56	2
11	9-4J-11	推动块	Pushing Plate	1
12	9-4J-12	垫块	Block	1
13	9-4J-13	支架	Support	1
14	9-4J-14	支板	Support Plate	1
15	9-4J-15	气缸PB-12x40-R	Cylinder PB-12x40-R	2
16	9-4J-16	导向架	Guide Bracket	1
17	9-4J-17	导向杆	Guide Screw	1
18	9-4J-18	钩线杆组件	Thread Hooking Rod Complete	1
19	9-4J-19	支架组件	Bracket Complete	1
20	7A-26	螺母 M5	Nut M5	2
21	9G-19a	螺钉 M5x10	Screw M5x10	1
22	9-4J-43	垫圈	Washer	5
23	7E-29	一字槽螺钉 M5x8.3	Screw M5x8.3	5
24	8E-22	外齿弹性垫圈	Washer	1
25	C-71-4	垫圈	Washer	1
26	9-3J-14	剪线气缸 MD20x12-1F	Trimmer Cylinder MD20x12-1F	1
27	B-26	螺母 M4	Nut M4	1
28	9G-35a	螺钉 1/8-44	Screw 1/8-44	2
29	9-4J-24	吹针导管	Tube For Blowing Reedle	1
30	9-4J-25	铜管夹	Copper Pipe Clamp	1
31	9-4J-26	螺钉 55/256-32	Screw 55/256-32	1
32	9-4J-40	自攻螺钉	Wood Screw	3
33	C-51	垫圈	Washer	3
34	B-25	弹簧垫圈	Spring Washer	3
35	A-30	十字头螺钉 M4x6	Screw M4x6	3
36	9-4J-37	顶罩	Cover	1
37	9E-17	一字槽螺钉 23/128-40	Screw 23/128-40	1
38	9-3J-38	皮带罩组件	Belt Cover Complete	1
39	9-4J-36	加固板	Gusset Plate	1
40	B-26	螺母 M4	Nut M4	1
41	9-4J-22	取线杆	Thread Rod	1
42	9-4J-42	铰链螺钉 3/16-32	Hinge Screw 3/16-32	1
43	9-4J-21	导向块	Buidnig Block	1
44	B-40	紧定螺钉 M4x4	Set Screw M4x4	1
45	8G-54	电线夹	Fastening Band	1
46	4D-37	十字槽螺钉 9/64-40	Screw 9/64-40	1
47	9-3B-23	一字槽螺钉 11/64-40	Screw 11/64-40	2
48	13A-29	螺钉	Screw	1
49	10A-61	垫圈	Washer	1