

INSTRUCTION MANUAL

Before cutting, connect the attachment code to the machine and grind the knife edge sharp by pushing the spring loaded projection grinding switch (B) for several times.

CHECKING(Release connecting plugs)

A. Greasing

1. Every 50 hours : Give small quantity grease thru grease cup and turn the cap (A) in
2. Every 150 hours : Release cap (A) and fill the grease.

B. Lubrication

Every 10-20 hours : Give oil to knife oiler (D) until oil comes in contact with the surface of knife edge

C. Adjustment of Re-Sharpener

While the grinding wheel wears loosen stop nut of resharpenner-arm (J) and rectify the resharpenner position so as to the grinding wheel keeps proper contact with the knife edge.

D. Replacement of Grinding wheel

* See Grinding Wheel Replacement Guide

E. Replacement of knife

1. Remove the knife guard (E) to upward direction.
1. Remove the knife guard (E) to upward Direction.
3. Remove safty plate(1) releasing lock nut (H).
4. Remove knife lock lock nut (c) by turning it loft. Use the wrench attached. (If the knife also turns together with lock nut. lock the knife to the standard inseting lock shaft to hole in the knife (L). The corresponding hole for locking knife is also provided in the standard.)
5. Remove knife.
6. Be sure the front face of the knife when re-setting the knife. [HSS-100] marked face is the front face.
7. Adjust the position of re-sharpener(K) after each replacement of knife.

F. Replacement of Carbon Brush

1. Too much weaving of carbon brush will cause motor troubles. Carbon brush must be replaced when it wears to 5-6mm
2. Carbon brush cap (G) is replaced by turning it left by attached wrench.
3. Always replace right and left carbon brushes simltaneously .
4. Be sure to hold metallic part of the brush. keep fingers away from carbon.

Caution:

1. For safety purpose, retain the knife guard (E) at the lowest location while the machine is not applied. Also keep the guard closest possible to the work while cutting,
2. Connect earth wire for safety

SPECIFICATIONS

Knife Size	: 100mm
Knife Shape	: Octagon*
Cutting Capacity	: 25mm(1")
Net Weight	: 2.9kgs
Voltage	: Single Phase 100V-120V 220V-240V
Power	: 100W

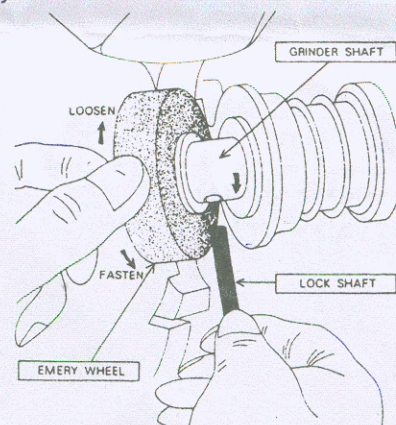

Hold the grinding wheel by hand, insert the attached lock shaft to the hole provided in grinder shaft and turn to arrow indication. Remove,used wheel and replace with new.

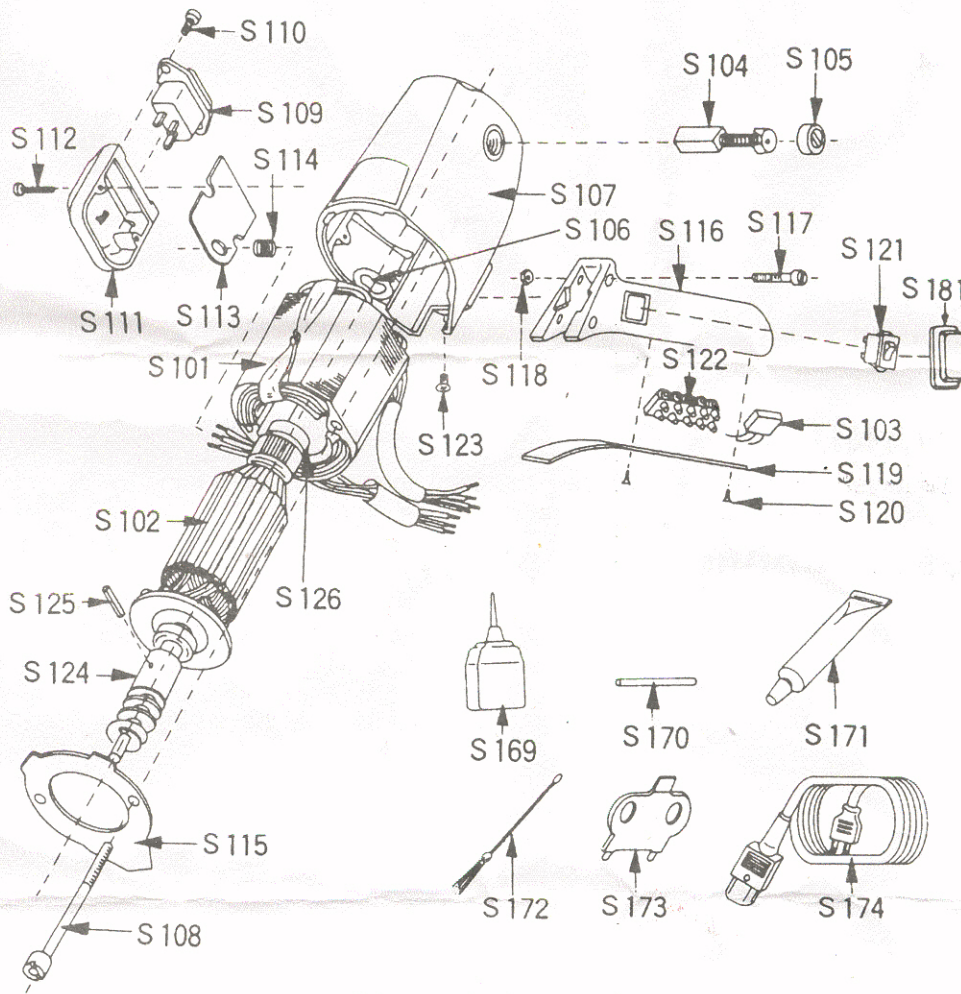

PART NO.	PART NAME
S-101	Stator
S-102	Rotor
S-103	Condenser
S-104	Carbon Brush
S-105	Cap for Carbon Brush
S-106	Wave Washer
S-107	Motor Cover
S-108	Screw for Stator
S-109	Terminal
S-110	Screw for Terminal
S-111	Terminal Box
S-112	Screw for T.BOX
S-113	Terminal Plate
S-114	Rubber Bushing
S-115	Air Guide
S-116	Drive Handle
S-117	Serew for Handle
S-118	Nut for Handle
S-119	Cover for Handle
S-120	Screw for Cover
S-121	Swich
S-122	Connecting Terminal
S-123	Screw for Earth
S-124	Drive Gear
S-125	Roll Pin
S-126	Bearing
S-127	Gear Box
S-128	Screw for G.Box
S-129	Drive Gear Metal
S-130	Cover for Metal
S-131	Knife Gear
S-132	Shaft Gear
S-133	Shaft Gear Scrsult
S-134	Ring for Gear
S-135	Knife(8-sided)※Round(option)
S-136	Lock Nut for Knife
S-137	Knife Oller
S-138	Screw for Oller
S-139	Spring for Oller
S-140	Oil Felt
S-141	Knife Guard
S-142	S[ring for Guard
S-143	Screw for Spring
S-144	Safety Plate
S-145	Screw for Plate
S-146	Spring Washer for Plate
S-147	Grease Cup
S-148	Cap for Grease Cup
S-149	Qrinder Shaft
S-150	Emery Wheel
S-151	Grinder Spring
S-152	Grinder Collar
S-153	Spring for Collar
S-154	Sharpening Switch
S-155	Grinder Arm
S-156	Screw for Grinder Arm
S-157	Standard
S-158	Screw for Standard(upside)
S-159	Screw for Standard(bottom)
S-160	Guide Plate
S-161	Screw for Guide Plate
S-162	Base Plate
S-163	Front Roller
S-164	Roller Shaft(front)
S-165	Roller Shaft(rear)
S-166	Screw for Roller Shaft
S-169	Oller
S-170	Lock Shaft
S-171	Grease
S-172	Cleaning Brush
S-173	Wrench
S-174	Code Complete with earth
S-175	Lower Blade
S-176	Screw for Lower Blade
S-177	Washer for Lower Blade
S-178	Pressure Spring for Lower Blade
S-179	Screw for Pressure Spring
S-180	Rear Roller Set
S-181	Switch Cap
S-182	Nut for Knife Gear Screw
S-183	Washer for Knife Gear Scres

Other standard accessories:

- Knife(S135) 1 pc.
- Carbon brush(S104) 1 set.
- Grinding wheel(S150) 1pc.
- Knife oiler felt(S140) 1pc.

