

杰克缝纫机  
全球销量遥遥领先  
Leading in global sales

400-8876-858  
www.chinajack.com



JACK SEWING MACHINE CO.,LTD.

2019年4月份 Edition:April, 2019

杰克缝纫机股份有限公司

浙江省台州市椒江区机场南路15号  
电话 :0086-576-88177788 88177789  
传真 :0086-576-88177758  
产品标准代号 : Q/TK 007-2017  
资料如有更改,恕不另行通知,以实样为准

JACK SEWING MACHINE CO.,LTD.

No. 15 Airport South Road, Jiaojiang District, Taizhou, Zhejiang, PRC  
TEL: 0086-576-88177782 88177767 E-mail: sales@chinajack.com  
FAX: 0086-576-88177787 www.chinajack.com

Standard code of the products:Q/TK 007-2017  
You will be not informed if the file has been revised. Please set sample as standard.



## MS-90A 零件图册 Parts book

# JACK 杰克

# 目 录/CONTENTS

1、	机体部分 / Machine body.....	1
2、	机体部分(台面) / Machine body(Table structure).....	3
3、	旋梭油盘 / Machine body(Rotating shuttle oil pan).....	5
4、	上轴装置 / Upper shaft bar mechanism.....	7
5、	针杆装置 / Needle bar mechanism.....	9
6、	X送料装置(齿轮齿条传动) / X Feed mechanism(Gear-ract drive).....	11
6.1、	X送料装置(丝杠传动) / X Feed mechanism(Screw drive).....	15
6.2、	X送料装置(同步带传动)(选配) / X Feed mechanism(Timing Belt drive)(SELECTABLE)....	17
7、	送料装置(丝杆传动) / Feed mechanism(Screw drive).....	21
8、	送料装置(夹具C) / Feed mechanism(fixture C).....	23
8.1、	送料装置(压框夹具S) / Feed mechanism(Clamping fixture S).....	25
8.2、	送料装置(夹扣夹具S)(选配) / Feed mechanism(Clamping fixture S)(SELECTABLE).....	27
8.3、	送料装置(压框夹具T)(选配) / Feed mechanism(Clamping fixture T)(SELECTABLE).....	29
8.4、	送料装置(夹扣夹具T)(选配) / Feed mechanism(Clamping fixture T)(SELECTABLE).....	31
9、	抬压脚装置 / Work clamp lifter mechanism.....	33
10、	下轴装置 / Lower shaft mechanism.....	35
11、	供油润滑装置 / Lubrication mechanism.....	37
12、	穿线装置 / Threading mechanism.....	39
13、	卷线装置 / Bobbin winder mechanism.....	41
14、	切线装置 / Thread trimmer mechanism.....	43
15、	挡线部件 / Stop line components.....	45
16、	扫线装置 / Thread wiper mechanism.....	47
17、	松线装置 / Tension release mechanism.....	49
18、	大压脚装置 / External work clamp mechanism.....	51
19、	断线感应装置 / Thread breakage detector mechanism.....	53
20、	控制箱装置 / Control box mechanism.....	55
21、	开关装置 / Switch mechanism.....	57
22、	空压装置 / Air pressure mechanism.....	59
23、	电气部分装置 / Power supply equipment mechanism.....	61
24、	操作界面装置 / Operation interface mechanism.....	63
25、	机架部件 / Table mechanism.....	65
26、	辅助台面装置 / Auxiliary table mechanism.....	67
27、	附件 / Accessories.....	69
28、	点笔装置(选配) / Pint pen mechanism(SELECTABLE).....	71

# 1、机体部分 / Machine body

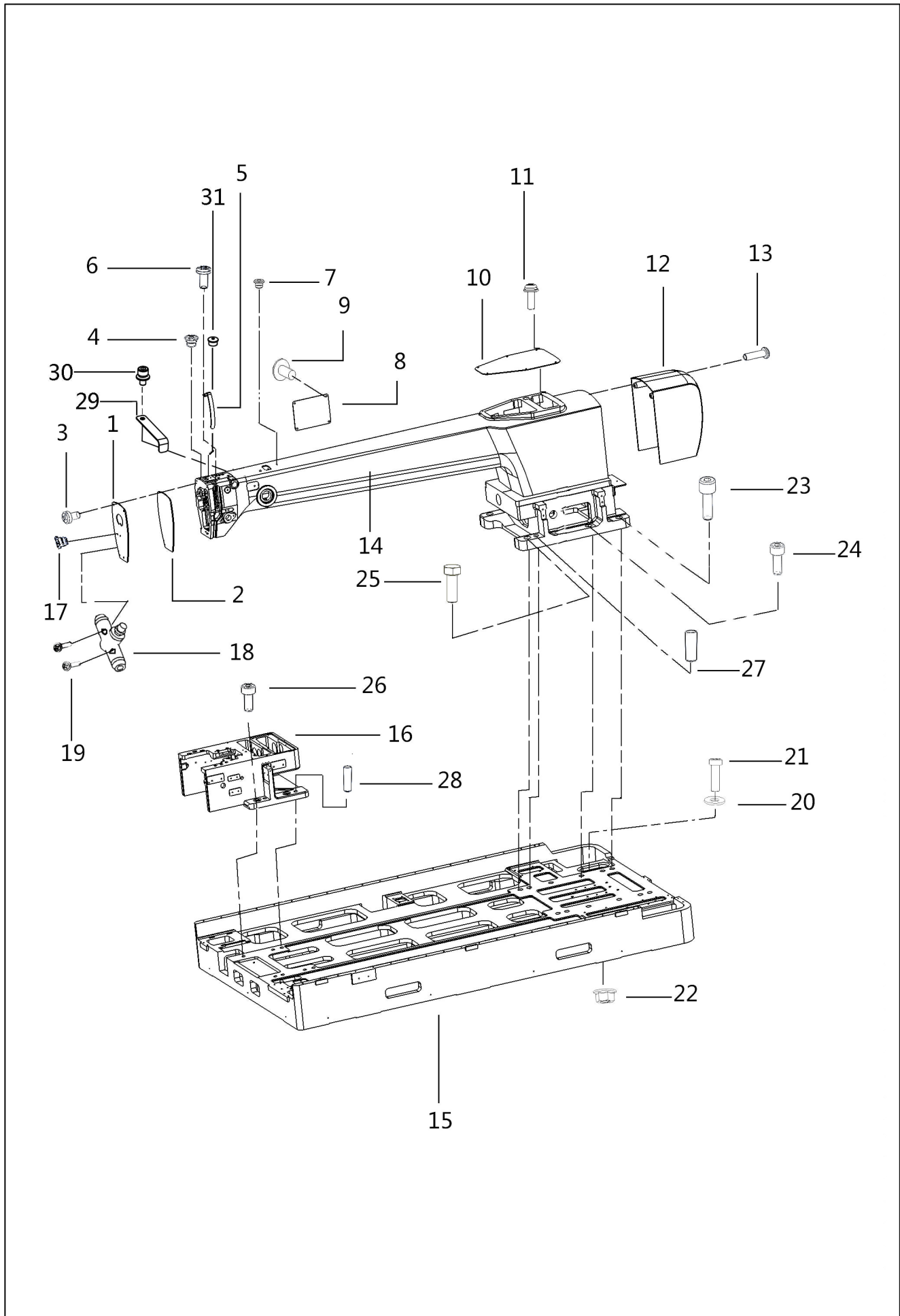

# 1、机体部分/Machine body

序号 Ref.No.	件号 Part.No	对象描述	Description	数量 Amt.	备注 Remarks
1	303883	面板	HEAD COVER	1	41812211
2	41812212	面板垫片	HEAD COVER	1	
3	S04028	螺钉M5×8 (镀铬)	SCREW M5×8	3	
4	41722009	橡皮塞 13	RUBBER CAP 13	1	
5	301760	挑线杆防护罩 (喷漆)	THREAD TAKE UP LEVER COVER	1	13512006
6	S04078	螺钉 M4×8(镀镍)	SCREW M4×8	1	
7	10122005	挑线连杆销螺孔塞	TAKE UP LEVER DOWEL RUBBER CAP	9	
8	304206	Y中窗板	Y REAR COVER	1	41812088
9	417S30025	螺栓 (带垫圈) M4×10DB	SCREW(WITH SHIM) M4×10DB	4	
10	304205	上盖板R	UPPER COVER PLATE R	1	41812058
11	417S30025	螺栓 (带垫圈) M4×10DB	SCREW(WITH SHIM) M4×10DB	6	
12	41811003	后罩	REAR COVER	1	
13	S04099	螺钉M6×16(镀镍)	SCREW M6×16	4	
14	304166	机头	HEAD	1	141801012
15	304167	基座	FOUNDATION SUPPORT	1	141801013
16	304168	底板前座	BASEPLATE FRONT SEAT	1	141801014
17	41722004	橡皮塞15.5	RUBBER CAP 15.5	2	
18	41845232	T形接管KJT04	T PIPE CONNECTION KJT04	1	
19	417S30023	螺栓 (带垫圈) M3X16DB	SCREW(WITH SHIM) M3X16DB	2	
20	41828013	大垫圈	BIG SCREW	4	
21	S05138	螺栓M16×75	SCREW M16×75	4	
22	N04003	法兰螺母M16	HEX FLANGE NUT M16	4	
23	S05137	螺栓M20×70	SCREW M20×70	2	
24	S05275	螺栓M20×55	SCREW M20×55	4	
25	L02083	外六角螺栓M20×70	HEX HEAD CAP SCREW M20X70	2	
26	S05276	螺栓M14X45	SCREW M14X45	4	
27	P02011	销子16×50	LOCATIN PIN 16×50	2	
28	P02012	销子12×50	LOCATIN PIN 12×50	2	
29	41812008	机头电线压板	HEAD WIRE PLATE	1	
30	417S30033	内六角圆柱头螺钉M4×8	HEXAGON HEAD SCREW	1	
31	40622014	油封	OIL SEAL	1	

## 2、机体部分（台面） / Machine body (Table structure)

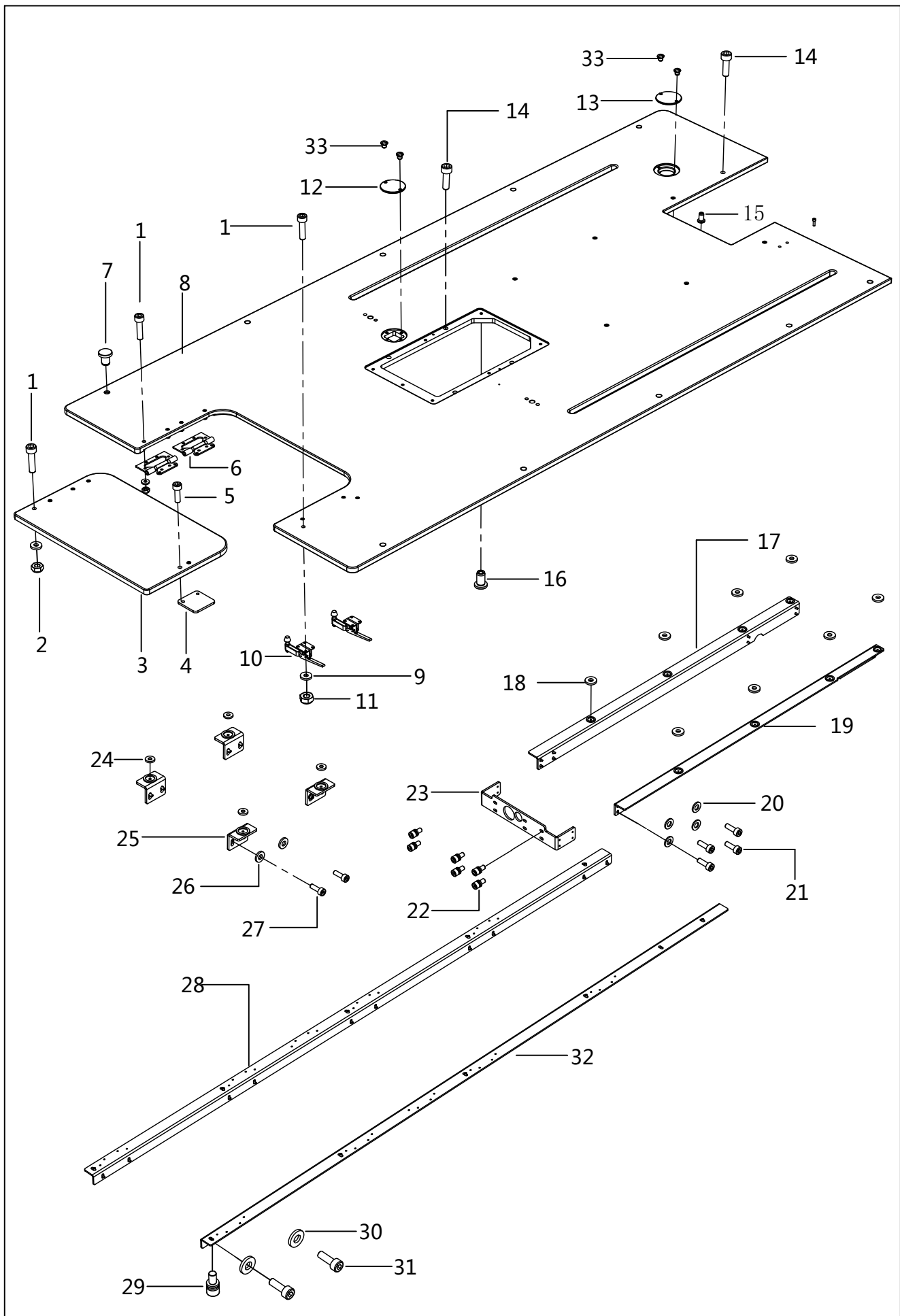

## 2、机体部分（面板） / Machine body (Table structure)

序号 Ref.No.	件号 Part.No	对象描述	Description	数量 Amt.	备注 Remarks
1	S05068	螺栓 M5×20(滚花,镀镍)	SCREW M5×20	12	
2	407N01001	自锁螺母M5	SELFLOCKING OUT M5	8	
3	41832624	开合台面	TABLE-BOARD OPENING AND CLOSING	1	
4	41812644	开合台面限位板	OPENING AND CLOSINGTABLE-BOARD LIMIT PLATE	1	
5	S05124	螺栓 M5×16(滚花,镀镍)	SCREW M5×16	2	
6	41831011	合页4寸	HINGE 4	2	
7	418S16014	滚花螺纹套M6	KNURLED THREAD SLEEVE M6	10	
8	41832011	台面	TABLE-BOARD	1	
9	41728028	垫圈M5	WASHER M5	12	
10	42231512	压紧夹具	CLAMPING FIXTURE	2	
11	407N01001	自锁螺母M5	SELFLOCKING OUT M5	4	
12	41832604	圆形盖板	CIRCULAR COVER PLATE	1	
13	41832022	台面盖板	TABLE COVER PLATE	1	
14	S05124	螺栓 M5×16(滚花,镀镍)	SCREW M5×16	12	
15	418S16015	滚花螺纹套M4	KNURLED THREAD SLEEVE M4	6	
16	418S16015	滚花螺纹套M4	KNURLED THREAD SLEEVE M4	7	
17	304210	台面左托架组件	MESA LEFT BRACKET COMPONENTS	1	4181213600
18	41822012	减振垫圈	BUFFER WASHER	8	
19	304211	台面右托架组件	MESA RIGHT BRACKET COMPONENTS	1	4181213800
20	W01009	垫圈M5	WASHER M5	16	
21	S05123	螺栓 M5×12(滚花,镀镍)	SCREW M5×12	16	
22	417S30037	螺栓 M6×14	SCREW M6×14	6	
23	304209	台面中支架	MESA BRACKET	1	41812135
24	41822012	减振垫圈	BUFFER WASHER	4	
25	4181204800	台面支撑板组件	COUNTERTOP SUPPORT PLATE ASSEMBLY	4	
26	41728028	垫圈M5	WASHER M5	8	
27	S05123	螺栓 M5×12(滚花,镀镍)	SCREW M5×12	8	
28	304207	台面左固定支架	MESA LEFT FIXED SUPPORT	1	41812046
29	417S30037	螺栓 M6×14	SCREW M6×14	11	
30	41728028	垫圈M5	WASHER M5	20	
31	S05123	M5×12(滚花,镀镍)	SCREW M5×12	20	
32	304208	台面右固定支架	MESA RIGHT FIXED SUPPORT	1	41812047
33	418S17211	沉头5X6	SCREW 5X6	4	

### 3、旋梭油盘 / Rotating shuttle oil pan

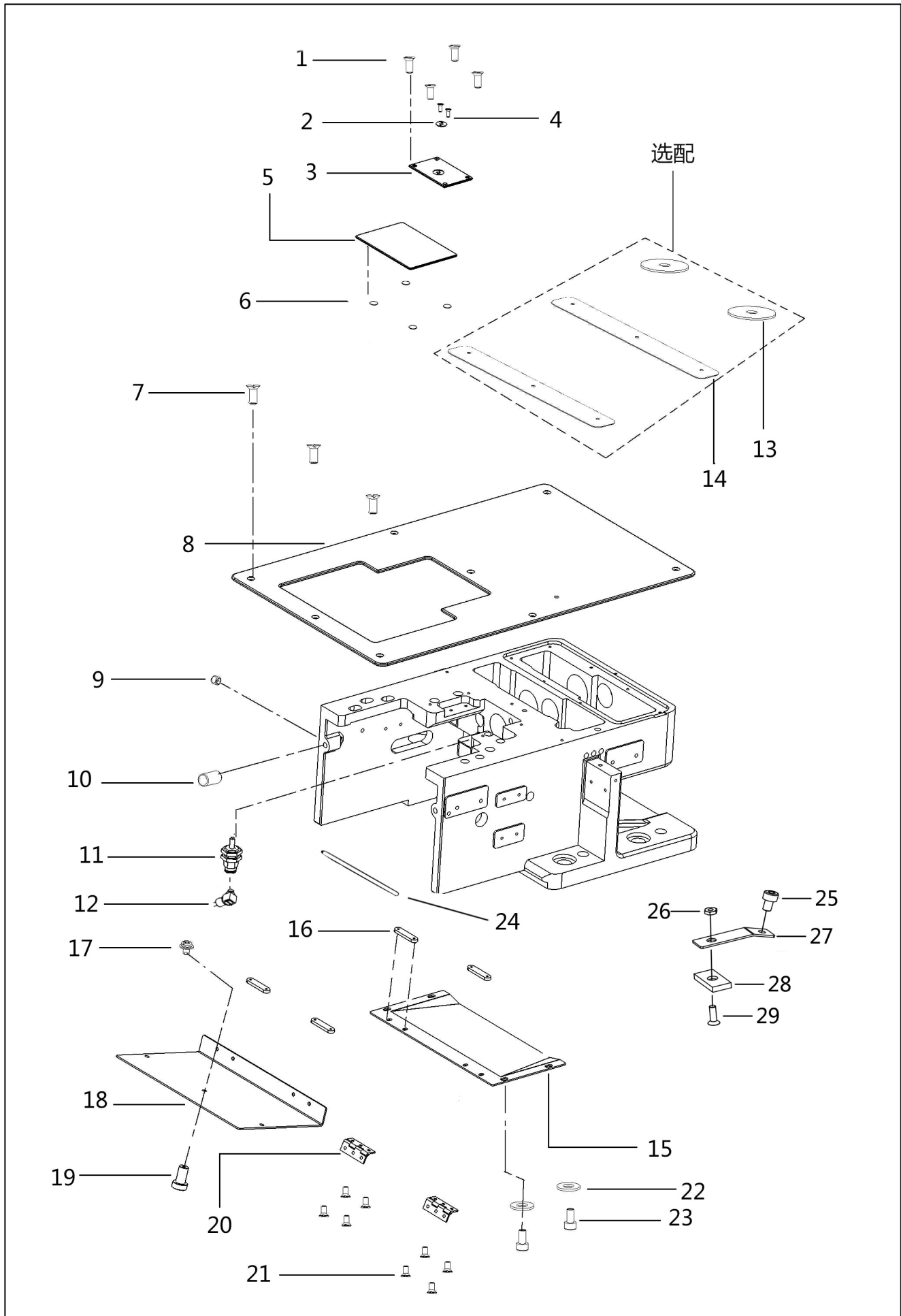

### 3、旋梭油盘/ Machine body (Rotating shuttle oil pan)

序号 Ref.No.	件号 Part.No	对象描述	Description	数量 Amt.	备注 Remarks
1	417S15008	螺钉M4×8	SCREW M4×8	4	
2	41815011	针孔板φ1.8T2.0	PINHOLE PLATE φ1.8T2.0	1	
3	41815015	针板	NEEDLE PLATE	1	
4	417S17001	螺钉 SM2.38	SCREW SM2.38	2	
5	41811005	旋梭上盖板	COVER THE SHUTTLE	1	
6	11401020	磁铁	MAGNET	4	
7	S02039	螺钉 M4×9(镀镍)	SCREW M4×9	8	
8	41811004	台面前盖板	TABLE FRONT COVER	1	
9	S09019	螺钉 M5×5(镀镍)	SCREW M5×5	2	
10	41831019	强力磁铁6×12	STRONG MAGNET 6×12	2	
11	41845012	气缸MPEF10×10	AIR CYLINDER MPEF10×10	1	
12	42230519	微型接头M-5HLH-4	MICRO PIPE CONNECTION M-5HLH-4	1	
13	41828014	前盖板垫圈	FRONT COVER WASHER	2	选配
14	41812101	前盖板垫板	FRONT COVER SUBPLATE	2	
15	41812053	挡油板	OIL BAFFLE PLATE	1	
16	41812055	板螺母M3	THE PLATE NUT	4	
17	421S11009	螺钉M4×6 ( 十字 )	SCREW M4×6 ( CORSS FITTING)	1	
18	304212	旋梭前盖	ROTATING SHUTTLE FRONT COVER	1	41812054
19	418S30014	旋钮螺钉M4	ROTARY KNOB SCREW	1	
20	41831012	铜合页1.5寸	COPPER HINGE 1.5	2	
21	S02032	螺钉 M3×6(镀镍)	SCREW M3×6	8	
22	W01001	垫片M4	WASHER M4	4	
23	S05116	螺栓 M4×8(滚花,镀镍)	BOLT M4×8	4	421S13035
24	12923018	油线4×4 ( 0.2m )	THE OIL LINE 4×4 ( 0.2m )	1	
25	S05115	螺栓M4×6(滚花,镀镍)	BOLT M4×6	1	
26	N01013	螺母M3(镀锌)	NUT M3	1	
27	41812006	磁铁固定板	MAGNET FIXING PLATE	1	
28	41831616	方形磁铁	SQUARE MAGNET	1	
29	114S17001	刀架压板螺钉	TOOL HOLDER PLATE SCREW	1	

# 4、上轴装置 / Upper shaft mechanism

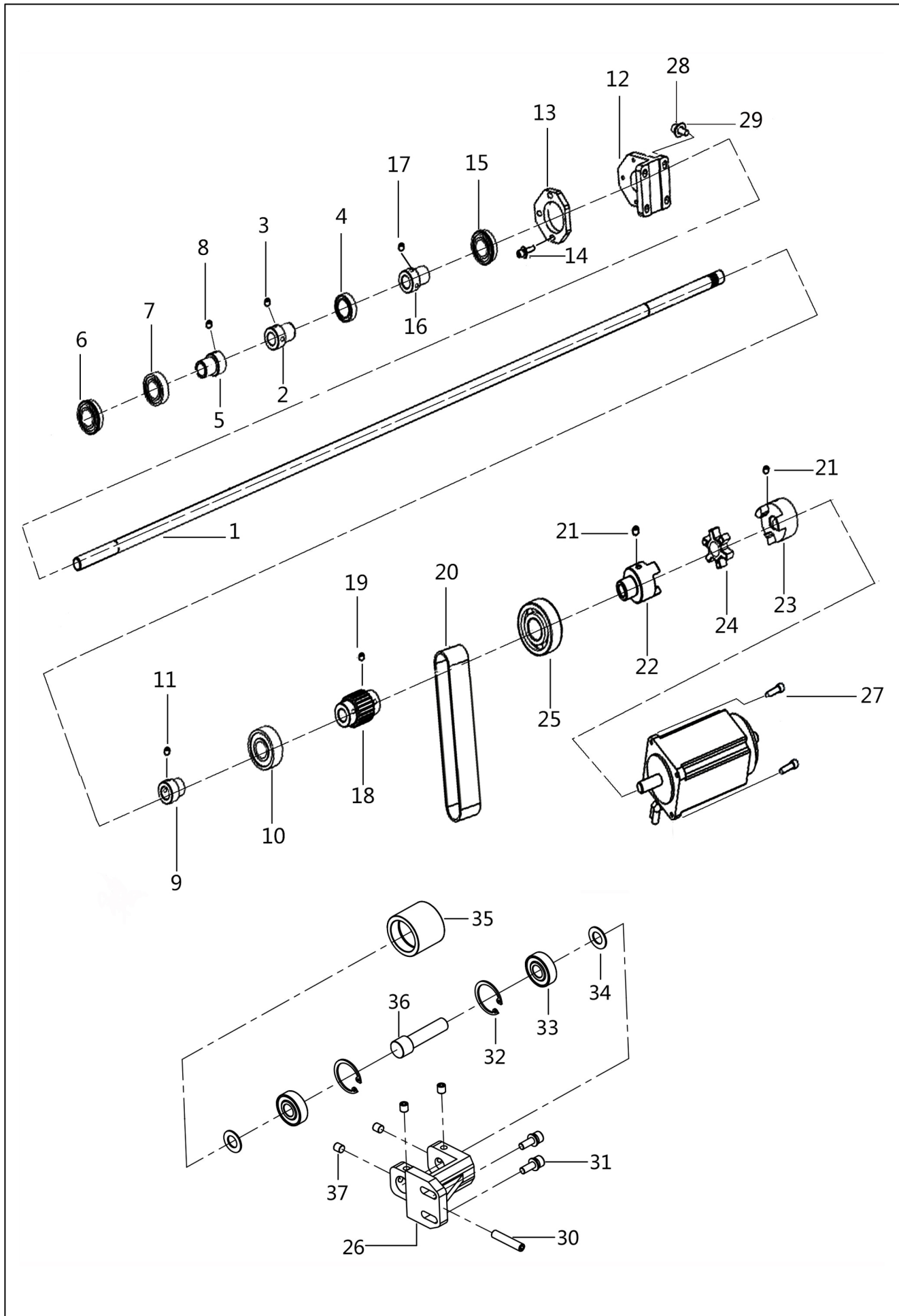

## 4、上轴装置/Upper shaft bar mechanism

序号 Ref.No.	件号 Part.No	对象描述	Description	数量 Amt.	备注 Remarks
1	41802015	上轴	UPPER SHAFT	1	
2	41703002	轴承套	BEARING SLEEVE	1	
3	S10018	凹端紧定螺钉 M6×6 发黑	CONCAVE END TIGHTENING SCREW M6×6	2	
4	B01024	轴承61804	BALL BEARING 61804	1	
5	41703002	轴承套	BEARING SLEEVE	1	
6	B10014	轴承 6904DDUNR	BALL BEARING 6904DDUNR	1	
7	B06005	轴承 R-6904DDU	BALL BEARING R-6904DDU	1	
8	S10018	凹端紧定螺钉 M6×6 发黑	CONCAVE END TIGHTENING SCREW M6×6	2	
9	41803212	轴承套	BEARING SLEEVE	1	
10	B01029	轴承 6204DDUNR	BALL BEARING 6204DDUNR	1	
11	S10019	螺钉 M6X6(镀铬)(进口)	SCREW M6×6	2	
12	41801048	上轴轴承支架座	UPPER SHAFT BALL BEARING ARM STAND	1	
13	41801049	上轴轴承支架	UPPER SHAFT BALL BEARING SUPPORT	1	
14	417S30306	螺栓 (带垫圈) M5×15	SCREW(WITH SHIM)M5×15	3	
15	B10014	轴承 6904DDUNR	BALL BEARING 6904DDUNR	1	
16	41703002	轴承套	BEARING SLEEVE	1	
17	S10018	凹端紧定螺钉 M6×6 发黑	CONCAVE END TIGHTENING SCREW M6×6	2	
18	4183502000	上轴同步轮组件	UPPER SHAFT SYNCHRONOUS WHEEL UNIT	1	
19	S10019	螺钉 M6×6(镀铬)	SCREW M6×6	4	
20	41835021	同步带S5M	SYNCHRONOUS BELT S5M	1	
21	S10024	螺钉 M6×10(镀铬)	SCREW M6×10	4	
22	41803214	联轴器抱箍A	COUPLING FOR COUPLING A	1	
23	41803215	联轴器抱箍B	COUPLING FOR COUPLING B	1	
24	40322028	减震橡胶	SHOCK-REDUCING RUBBER	1	
25	B02007	轴承6305NR	BALL BEARING 6305NR	1	
26	41801043	张紧轮支架	TENSIONONG WHEEL BRACKET	1	
27	S05124	螺栓 M5×16(滚花,镀镍)	SCREW M5×16	4	
28	S05124	螺栓 M5×16(滚花,镀镍)	SCREW M5×16	4	
29	W01009	垫圈5	WASHER	4	
30	S10033	紧定螺钉M6×30	SET SCREW M6×30	1	
31	417S30306	螺栓(带垫圈)M5×15	BOLT(WITH WASHERS) M5×15	2	
32	H01009	挡圈26	BEAD FLANGE	2	
33	B06006	轴承6000-VV	BALL BEARING 6000-VV	2	
34	41728001	平垫圈10	PLAIN WASHER 10	2	
35	41803013	张紧轮	TENSION PULLEY	1	
36	41826017	张紧轴	TENSION AXIS	1	
37	S10019	螺钉 M6X6(镀铬)(进口)	SCREW M6×6	4	

## 5、针杆装置 / Needle bar mechanism

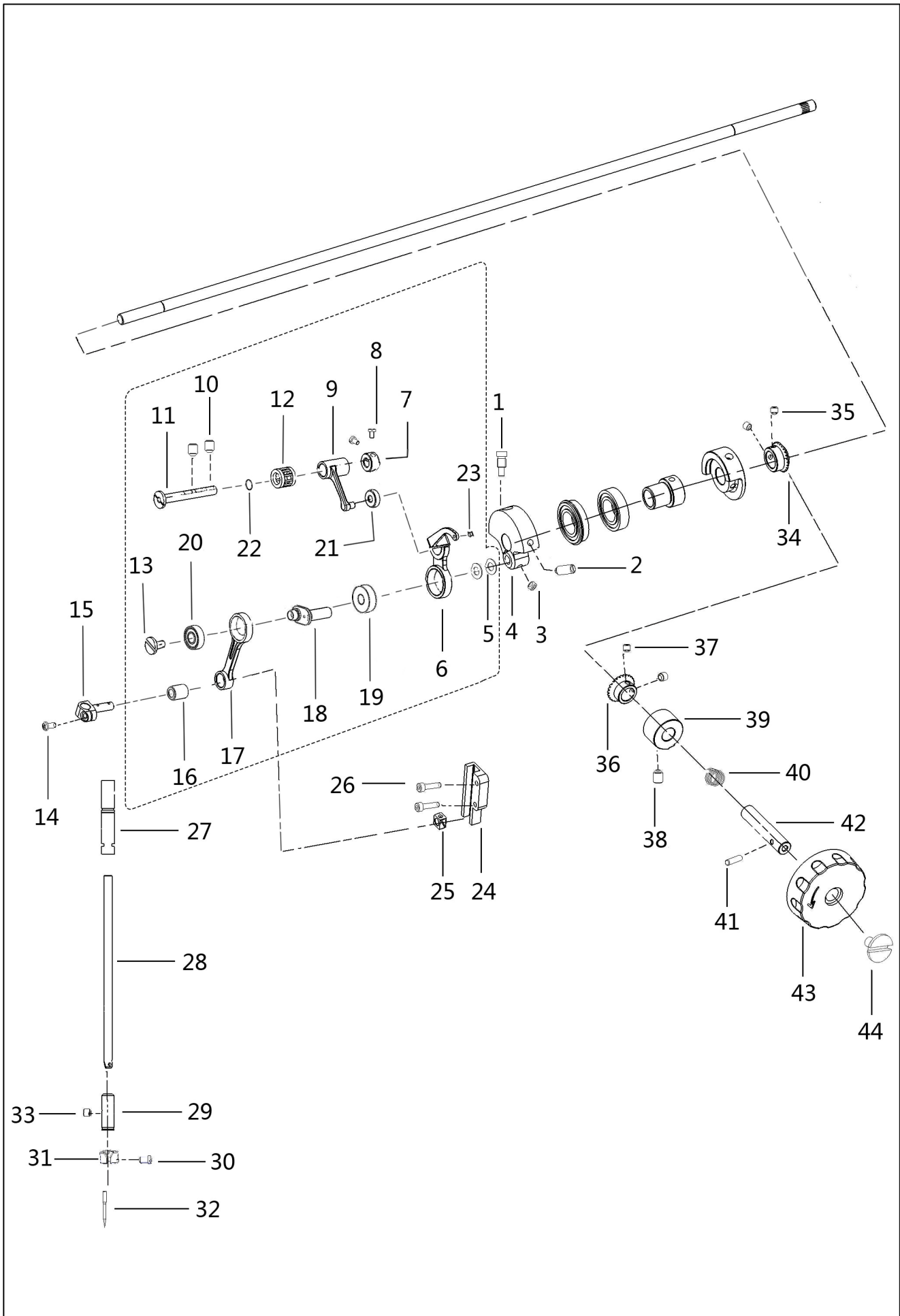

## 5、针杆装置/Needle bar mechanism

序号 Ref.No.	件号 Part.No	对象描述	Description	数量 Amt.	备注 Remarks
1	135S11002	针杆曲柄定位螺钉	NEEDLE BAR CRANK POSITIONING SCREW	1	
2	101S15004	针杆曲柄紧定螺钉	NEEDLE BAR CRANK TIGHTENING SCREW	1	
3	116S14003	针杆曲柄销定位螺钉	PIN LEVER CRANK PIN POSITIONING SCREW	2	101S14001
4	41804011	针杆曲柄A	NEEDLE BAR CRANK A	1	
5	41712133	垫圈 8	WASHER 8	2	
6	41838212	挑线杆	TAKE UP LEVER	1	4183801100 挑线连杆组 件A内部零件
7	41808211	挡圈 B	CLOSING RING B	1	
8	114S14001	紧钉螺钉	SCREW BOLT	2	
9	41805213	挑线连杆	PICK LINE CONNECTING ROD	1	
10	S10019	螺钉 M6X6(镀铬)	SCREW M6×6	2	
11	41804216	针杆连接柱	NEEDLE BAR CONNECTION COLUMN	1	4183801100 挑线连杆组 件A内部零件
12	42224005	滚针轴承	NEEDLE BEARING	2	
13	101S17001	挑线曲柄螺钉 (左旋)	NEEDLE BAR CRANK SCREW (LEVOROTATION)	1	
14	S04078	螺钉 M4×8(镀镍)	SCREW M4×8	1	
15	41704100	针杆接头	THE NEEDLE BAR JOINT	1	
16	41803222	针杆连杆铜套	NEEDLE ROD AND CONNECTING ROD COPPER	1	4183801100 挑线连杆组 件A内部零件
17	41805215	针杆连杆	NEEDLE BAR CONNECTING ROD	1	
18	41804215	挑线曲柄分部件	PICK UP THE CRAKE PARTS	1	
19	B06016	轴承618VV	BEARING 618VV	1	
20	B04031	轴承619/8-ZZ	BEARING 619/8-ZZ	1	
21	B04030	轴承628/6-ZZ	BEARING 628/6-ZZ	1	
22	41811221	垫圈	WASHER	2	
23	41813214	过线套	OVER LINE SLEEVE	1	
24	41709002	滑块导向 B	SLIDING BLOCK GUIDE B	1	
25	41709001	滑块	SLIDING BLOCK	1	
26	S05118	螺栓 M4×16(滚花,镀镍)	SCREW M4×16	2	
27	41703005	针杆轴套 UK	NEEDLE BAR SHAFT SLEEVE UK	1	
28	41702061	针杆(DLC)	NEEDLE BAR(DLC)	1	
29	42203508	针棒轴套D	NEEDLE ROD BUSHING D	1	
30	417S15002	螺钉 SM3.57-40×4.5	SCREW SM3.57-40×4.5	1	
31	41726014	针套	NEEDLE GUARD	1	
32	42217503	机针DP×5 9#	NEEDLE DP×5 9#	1	
33	S09019	螺钉 M5×5(镀镍)	SCREW M5×5	1	
34	40325010	上轴转动齿轮	TURN THE GEAR ON THE SHAFT	1	
35	S09019	螺钉 M5×5(镀镍)	SCREW M5×5	2	齿轮自带
36	40325011	手轮轴齿轮	HAND WHEEL SHAFT GEAR	1	
37	S09019	螺钉 M5×5(镀镍)	SCREW M5×5	2	齿轮自带
38	S10019	螺钉 M6X6(镀铬)	SCREW M6×6	1	
39	41803020	手轮轴套B	HAND WHEEL AXIE SLEEVE	1	
40	41827214	弹簧	SPRING	1	
41	P03002	销4X16	PIN 4X16	1	
42	41802212	手轮轴	THE HAND WHEEL	1	
43	40311003	手轮 (仿手印)	HAND WHEEL	1	
44	403S11003	手轮固定螺钉	HAND WHEEL SET SCREW	1	

# 6、X送料装置/X Feed mechanism

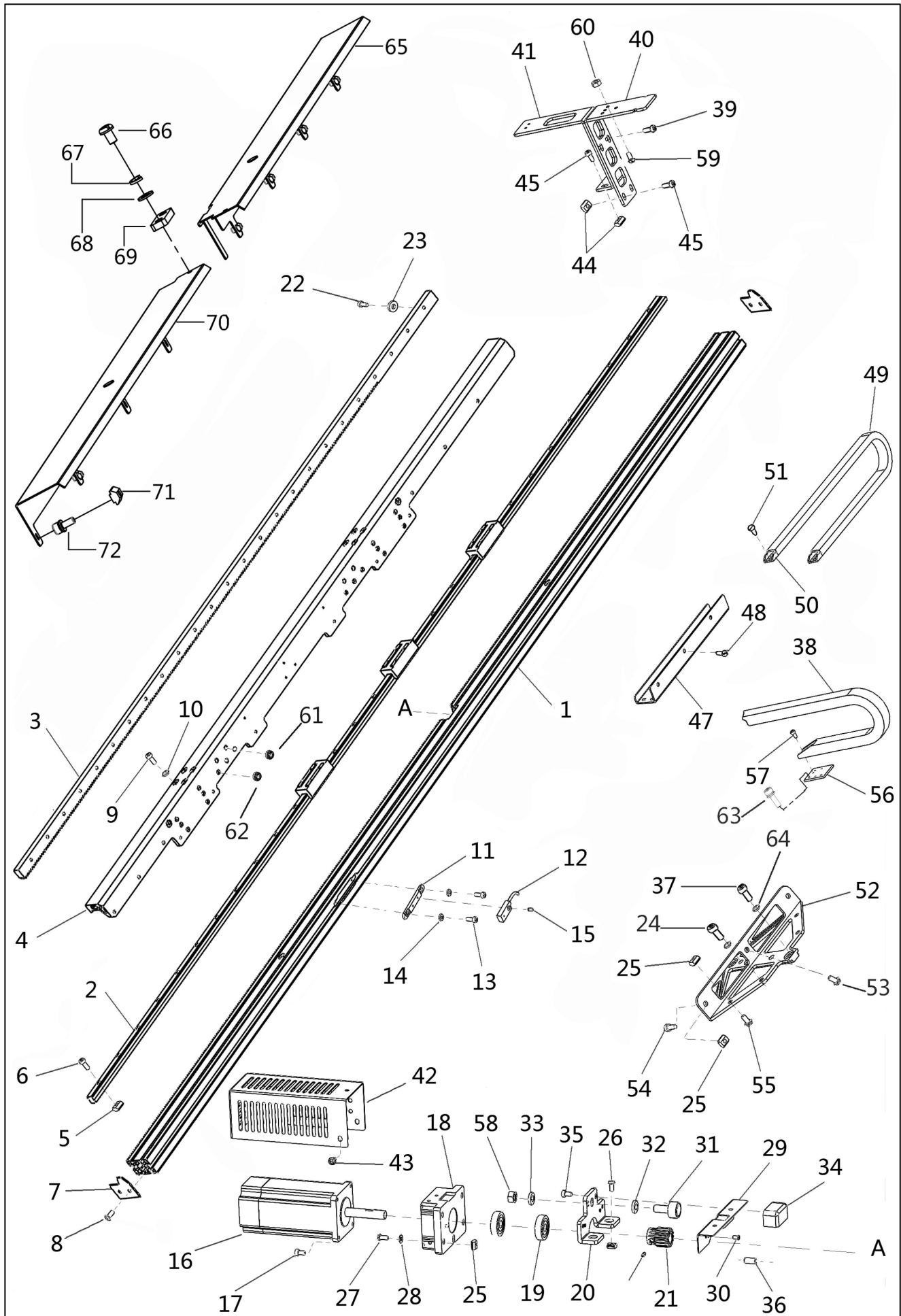

## 6、X送料装置/X Feed mechanism

序号 Ref.No.	件号 Part.No	对象描述	Description	数量 Amt.	备注 Remarks
1	41842029	X送料基座L14	X FEEDING BASE L14	1	
2	41824013	X导轨L14	X GUIDE RAIL L14	1	
3	41825012	X齿条L14	X RACK L14	1	
4	41842031	导轨齿条联接座YL14 (压紧方式)	GUIDE RACK CONNECTING SEAT YL14	1	
5	418S16012	方形螺母块20M4	SQUARE NUT 20M4	34	
6	S05118	螺栓 M4×16(滚花,镀镍)	SCREW M4×16	34	
7	41812017	X导轨挡板	X GUIDE BAFFLE	2	
8	S04038	螺钉M6×10	SCREW M6×10	4	
9	S05048	螺钉M4×10	SCREW M4×10	8	413S13017
10	41728024	垫片M4	WASHER M4	8	
11	41812020	X传感器安装板	X SENSOR MOUNTING PLATE	1	
12	41730851	传感器	SENSOR	1	
13	S05048	螺钉M4×10	SCREW M4×10	2	413S13017
14	W01001	垫片M4	WASHER M4	2	
15	S04076	螺钉M3×8(镀镍)	SCREW M3×8	1	
16	41833011	X步进电机B	X STEPPING MOTOR B	1	
17	S05010	螺钉M4×12	SCREW M4×12	4	
18	41842017	电机安装座	MOTOR SAFETY SEAT	1	
19	B01025	轴承6200	BALL BEARING 6200	1	
20	41812272	电机座安装支架	MOTOR MOUNTING BRACKET	1	
21	42225515	X送料齿轮14	X FEEDING RACK 14	1	
22	S05118	螺栓 M4×16(滚花,镀镍)	SCREW M4×16	29	
23	W01001	垫片M4	WASHER M4	31	
25	418S16011	方形螺母块20M5	SQUARE NUT 20M5	18	
24	S05111	螺栓M6×20	SCREW M6×20	4	
26	S05121	螺栓M5×10	SCREW M5×10	2	
27	S05123	螺栓 M5×12(滚花,镀镍)	SCREW M5×12	2	
28	41728028	垫圈5	WASHER 5	4	
29	41812026	齿轮盖板	GEAR PLATE	1	
30	S02031	螺钉M3×5	SCREW M3×5	2	
31	42224515	滚针导向轮	ROLLER GUIDE WHEEL	1	
32	41712133	垫圈8	WASHER 8	1	
33	41828011	垫圈8	WASHER 8	1	
34	41842018	导向轮盖	GUIDE WHEEL COVER	1	
35	S05116	螺栓 M4×8(滚花,镀镍)	SCREW M4×8	2	
36	41826011	圆柱销6×15	PIN 6×15	1	

# 6、X送料装置/X Feed mechanism

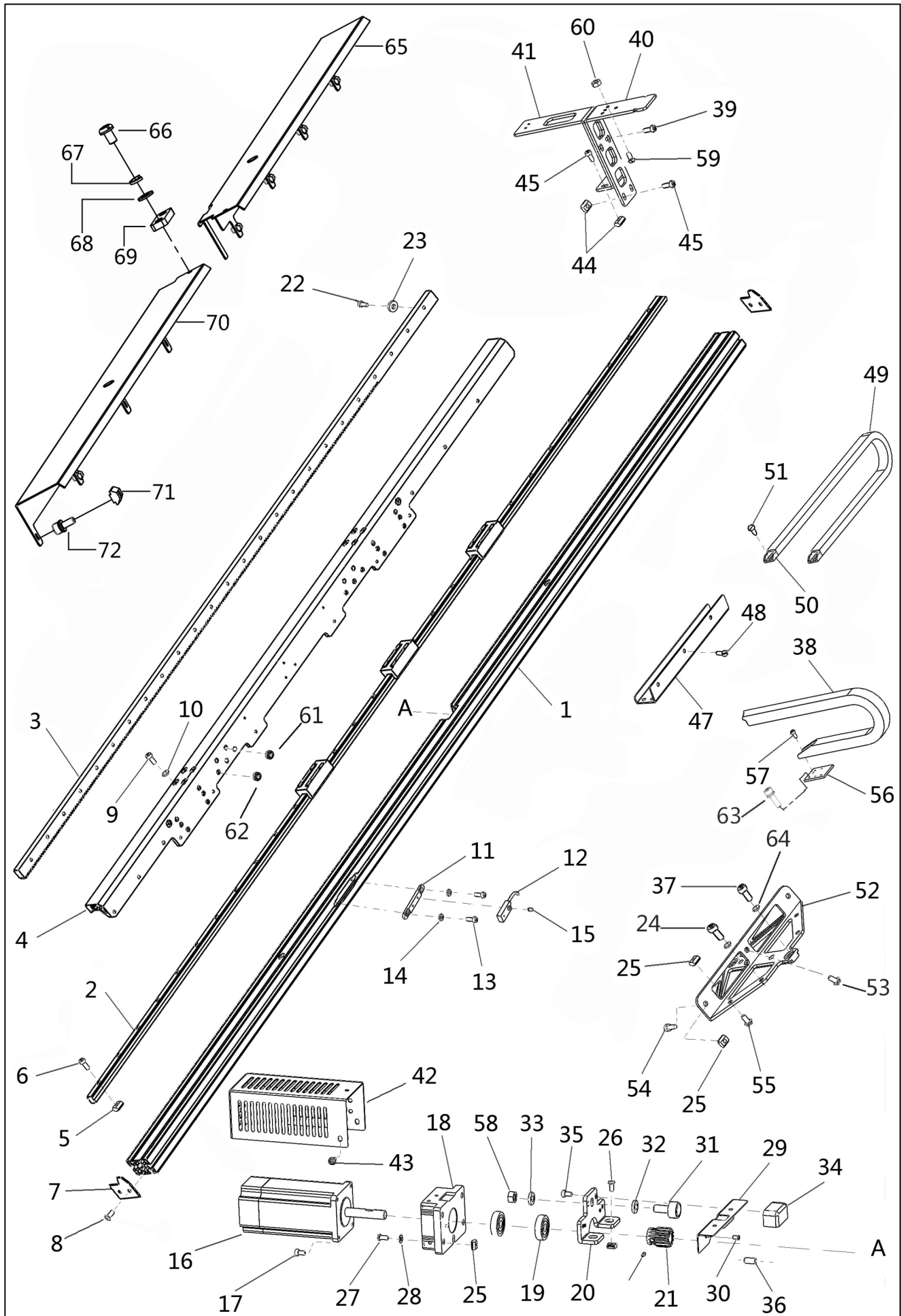

## 6、X送料装置(齿轮齿条传动)/X Feed mechanism(Gear-ract drive)

序号 Ref.No.	件号 Part.No	对象描述	Description	数量 Amt.	备注 Remarks
37	S05040	螺栓M6×16	SCREW M6×16	4	
38	41811027	塑料拖链1825	PLASTIC DRAG CHAIN 1825	1	
39	417S30033	螺钉M4×8	SCREW M4×8	2	
40	41812141	Y拖链前支架	Y DRAG CHAIN FRONT SUPPORT	1	
41	41812142	X拖链后支架	X DRAG CHAIN LATER SUPPORT	1	
42	304213	X电机罩	X MOTOR COVER	1	41812144
43	417S30025	螺栓(带垫圈)M4×10DB	SCREW(WITH SHIM) M4×10DB	3	
44	418S16012	方形螺母块20M4	SQUARE NUT 20M4	4	
45	S05048	螺钉M4×10	SCREW M4×10	4	413S13017
46	S05116	螺栓M4×8(滚花,镀镍)	SCREW M4×8	2	
47	4181203000	X右拖链支架组件	X DRAG CHAIN SUPPORT COMPONENTS	1	
48	417S15008	螺钉M4×8	SCREW M4×8	3	403S11013
49	42211526	塑料拖链0616	PLASTIC DRAG CHAIN 0616	1	
50	42211527	塑料拖链0616接头	PLASTIC DRAG CHAIN 0616 JOINT	1	
51	417S15008	螺钉M4×8	SCREW M4×8	4	403S11013
52	41801046	送料基座联接座	FEEDING BASE CONNECTING SEAT	2	
53	417S13301	螺栓M5X12	SCREW M5×12	2	
54	S05123	螺栓M5×12(滚花,镀镍)	SCREW M5×12	4	
55	S17005	螺栓M5X10	SCREW M5×10(COUNTERSUNK HEAD)	8	
56	41812134	Y拖链后支架	Y DRAG CHAIN LATER SUPPORT	1	
57	417S15008	螺钉M4×8	SCREW M4×8	2	403S11013
58	N01008	螺母M8	NUT M8	1	
59	422S15501	螺钉M4×10	SCREW M4×10	2	
60	N01024	螺母M4	NUT M4	2	
61	41708005	螺纹套	THREAD BUSHING	4	
62	418S16013	滚花螺纹套M5	KNURLED THREAD SLEEVE M5	6	
63	417S30034	螺钉(带垫圈)M4X14	SCREW M4×14	2	
64	42128040	垫片M6	WASHER M6	6	
65	304826	X右防尘罩(喷漆)	X RIGHT DUST SHIELD	1	41812434
66	S04028	螺钉M5×8(镀亮光铬)	SCREW M5×8	1	41812432
67	W02001	不锈钢弹垫M5	STAINLESS STEEL PAD M5	1	
68	W01009	垫圈5	WASHER 5	1	
69	41812222	板螺母	PLATE NUT	1	
70	304825	X左防尘罩(喷漆)	X RIGHT DUST SHIELD	1	41812432
71	418S16012	方形螺母块20M4	SQUARE NUT 20M4	8	
72	421S13012	螺钉带垫M4x10	SCREW M4×10	8	

## 6.1、X送料装置(丝杠传动)/X Feed mechanism(Screw drive)

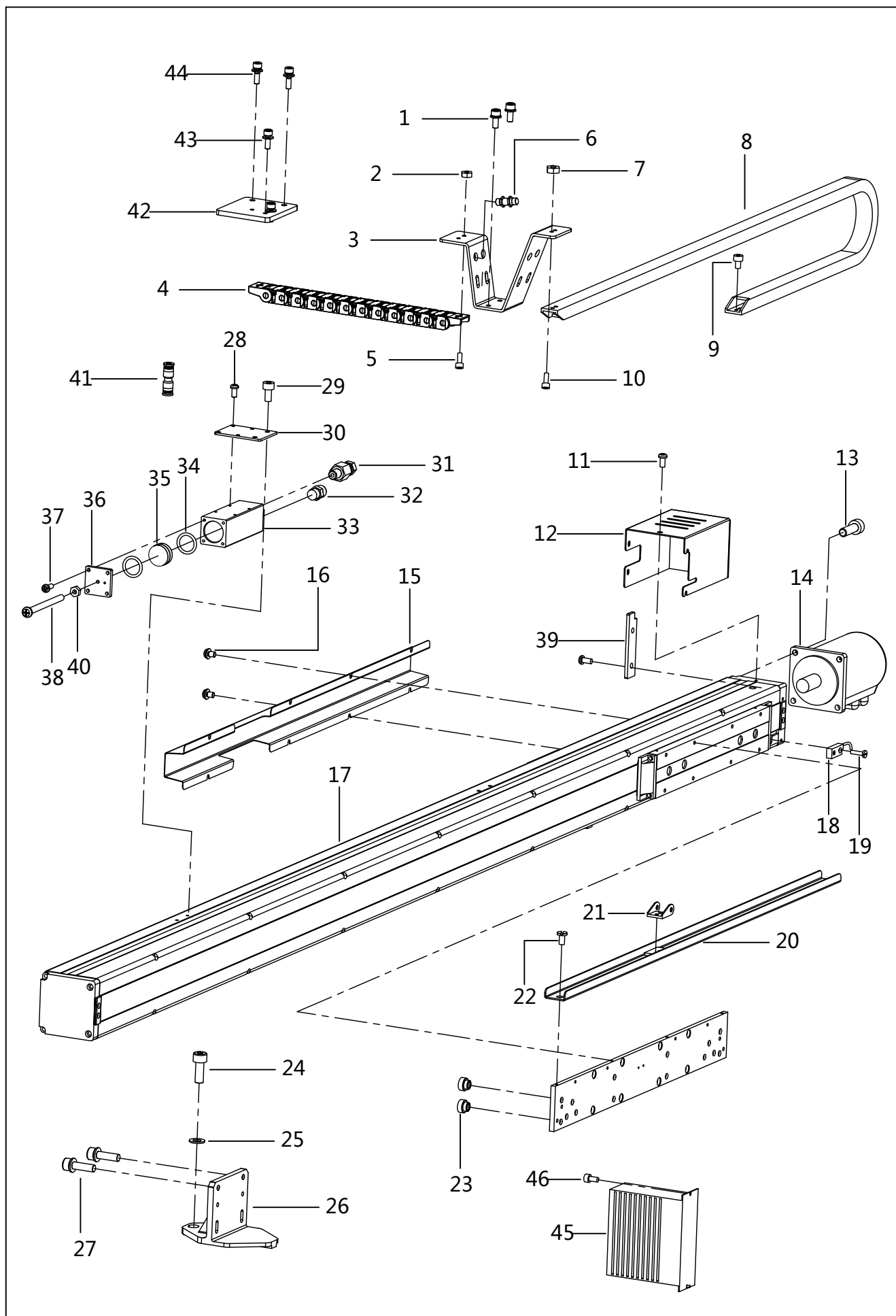

## 6.1、X送料装置(丝杠传动)/X Feed mechanism(Screw drive)

序号 Ref.No.	件号 Part.No	对象描述	Description	数量 Amt.	备注 Remarks
1	421S13027	螺钉M5X12(带垫圈)	SCREW M5×12	2	
2	407N1002	自锁螺母M4	NUT M4	2	
3	930000021	丝杆Y拖链支架	Y LEAD SCREW CHAIN BRACKET	1	141812008
4	41811027	塑料拖链1825	PLASTIC DRAG CHAIN 1825	1	
5	S05059	螺钉 M4×12(镀镍)	SCREW M4×12	2	
6	42136014	安装板直通接管(带螺纹)	MOUNTING PLATE THROUGH PIPE	2	
7	407N1002	自锁螺母M4	NUT M4	2	
8	141811001	小拖链	LITTLE PLASTIC DRAG CHAIN	1	
9	S05057	螺钉 M4×6(镀镍)	SCREW M4×6	2	
10	S05059	螺钉 M4×12(镀镍)	SCREW M4×12	2	
11	S04078	螺钉M4×8	SCREW M4×10	5	
12	930000022	丝杆电机罩	SCREW MOTOR COVER	1	141812010
13	S05124	螺栓 M5×16(滚花,镀镍)	SCREW M5×10	4	
14	41833016	X丝杆伺服电机	X SCREW SERVO MOTOR	1	
15	930000020	线罩	COVER WIRE	1	141812024
16	417S30025	十字槽盘头螺钉M4×10DB	PHILLIPS PAN HEAD SCREW M4×10	8	
17	4182401600	丝杆组件	SCREW COMPONENTS	1	
18	41730851	传感器	SENSOR	1	
19	421S13049	螺钉M3×12	SCREW M3×12	1	
20	1.4181E+10	丝杆拖链导板组件	LEAD SCREW CHAIN GUIDE COMPONENTS	1	
22	417S15008	螺钉 M4×8	COUNTERSUNK HEAD SCREW M4×8	4	
23	41708005	M5螺纹套	THREAD BUSHING M5	8	
24	S05040	螺栓 M6×16	SCREW M6×16	4	
25	42128040	垫片M6	WASHER M6	4	
26	41801052	丝杆送料联接座	SCREW FEEDING BASE CONNECTING SEAT	2	
27	421S13065	螺栓 M5×16(滚花,镀镍)(带垫圈)	SCREW M5×16	8	
28	S04082	螺钉M3X6	SCREW M3×6	4	
29	S05116	螺钉M4×8	SCREW M4×8	2	
30	41812146	储油脂盒安装板	GREASE STORAGE BOX MOUNTING PLATE	1	
31	41836011	铜卡套式直通油管接头M6	COPPER CARD-YYPE DIRECT TUBING JOINT M6	1	
32	41836018	直角油管接头90度M6	LUBRICATING NIPPLE M6	1	
33	41842041	Y丝杠储油脂盒	Y LEAD SCREW GREASE STORAGE BOX	1	
34	41822016	O型圈17×2.65	O-SHAPED RING	2	
35	41842042	活芯子	PISTON	1	
36	41812145	储油脂盒盖板	GREASE STORAGE COVER PLATE	1	
37	S04076	螺钉M3X8	SCREW M3X8	4	
38	S04125	十字槽盘头螺钉M4/50	SCREW M4X50	1	
39	141812027	垫块	PADDING BLOCK	1	
40	N01024	六角螺母M4	HEX NUT	1	
41	41836501	管接头PU4(直通)	GES POPE JOINT	1	
42	41812134	Y拖链后支架	Y DRAG CHAIN LATER SUPPORT	1	
43	S05115	螺栓(带垫圈)M4×6	SCREW M4×6	2	
44	417S30034	螺钉(带垫圈)M4X14	SCREW M4×14	2	
45	141830005	低压驱动器	DRIVE	1	
46	S05116	螺栓M4×8(滚花,镀镍)(切换)	SCREW M4×8	2	

## 6.2、X送料装置(同步带传动) / X Feed mechanism(Timing Belt drive)

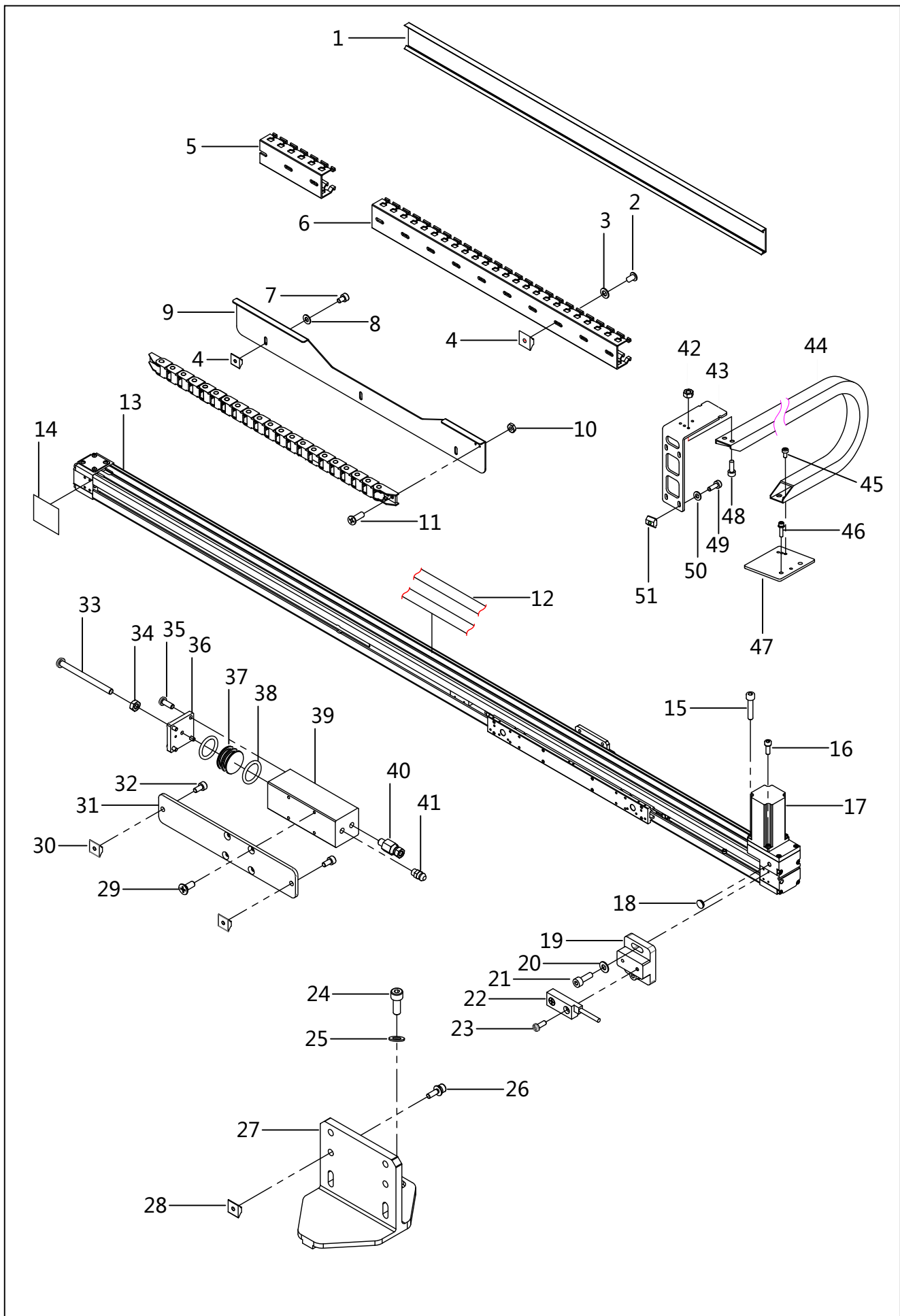

## 6.2、X送料装置(同步带传动)/X Feed mechanism(Screw drive)

序号 Ref.No.	件号 Part.No	对象描述	Description	数量 Amt.	备注 Remarks
1	141811006	线槽盖40L700	TRUNKING 40L700	1	
2	S05057	螺钉M4×6	SCREW M4×6	3	
3	W01001	平垫圈4	PLAIN WASHER4	3	
4	425S10001	方形螺母块	SQUARE NUT BLOCK	10	
5	141811005	线槽4030L120	TRUNKING 4030L120	1	
6	141811004	线槽4030L480	TRUNKING 4030L480	1	
7	417S15008	螺钉M4×8	SCREW M4×8	4	
8	41828012	垫圈4	PLAIN WASHER4	4	
9	141842008	小坦克链挡板	PANZER CHAIN BAFFLE	1	
10	N01013	螺母M3	NUT M3	2	
11	S02127	沉头螺钉M3×10	SCREW M3×10	2	
12	141831028	特氟龙胶带50	TEFLON TAPE 50	1	
13	4184205000	同步带送料模组	SYNCHORONOUS BELT FEED MECHANISM	1	
14	41837614	机械防撞标贴	MECHANICAL ANTI-COLLISION LABELING	2	
15	S05035	螺钉M5×25	SCREW M5×25	2	
16	S05124	螺栓M5×16	SCREW M5×16	2	
17	41833500	模组电机	X STEPPER MOTOR	1	
18	10122005	孔塞	DUST PLUG	1	
19	141842001	X传感器安装板	X SENSOR MOUNTING PLATE	1	
20	W01001	平垫圈4	PLAIN WASHER4	2	
21	S05010	螺钉M4×12	SCREW M4×12	2	
22	41730851	传感器	SENSOR	1	
23	S04076	螺钉M3×8	SCREW M3×8	1	
24	S05040	螺栓 M6×16	SCREW M6×16	4	
25	42128040	垫片M6	WASHER M6	4	
26	417S30034	螺栓 M4×14(带垫圈)	SCREW M4×14	8	
27	41801052	送料联接座	FEEDING BASE CONNECTING SEAT	2	
28	425S10001	方形螺母块	SQUARE NUT BLOCK	8	

## 6.2、X送料装置(同步带传动) / X Feed mechanism(Timing Belt drive)

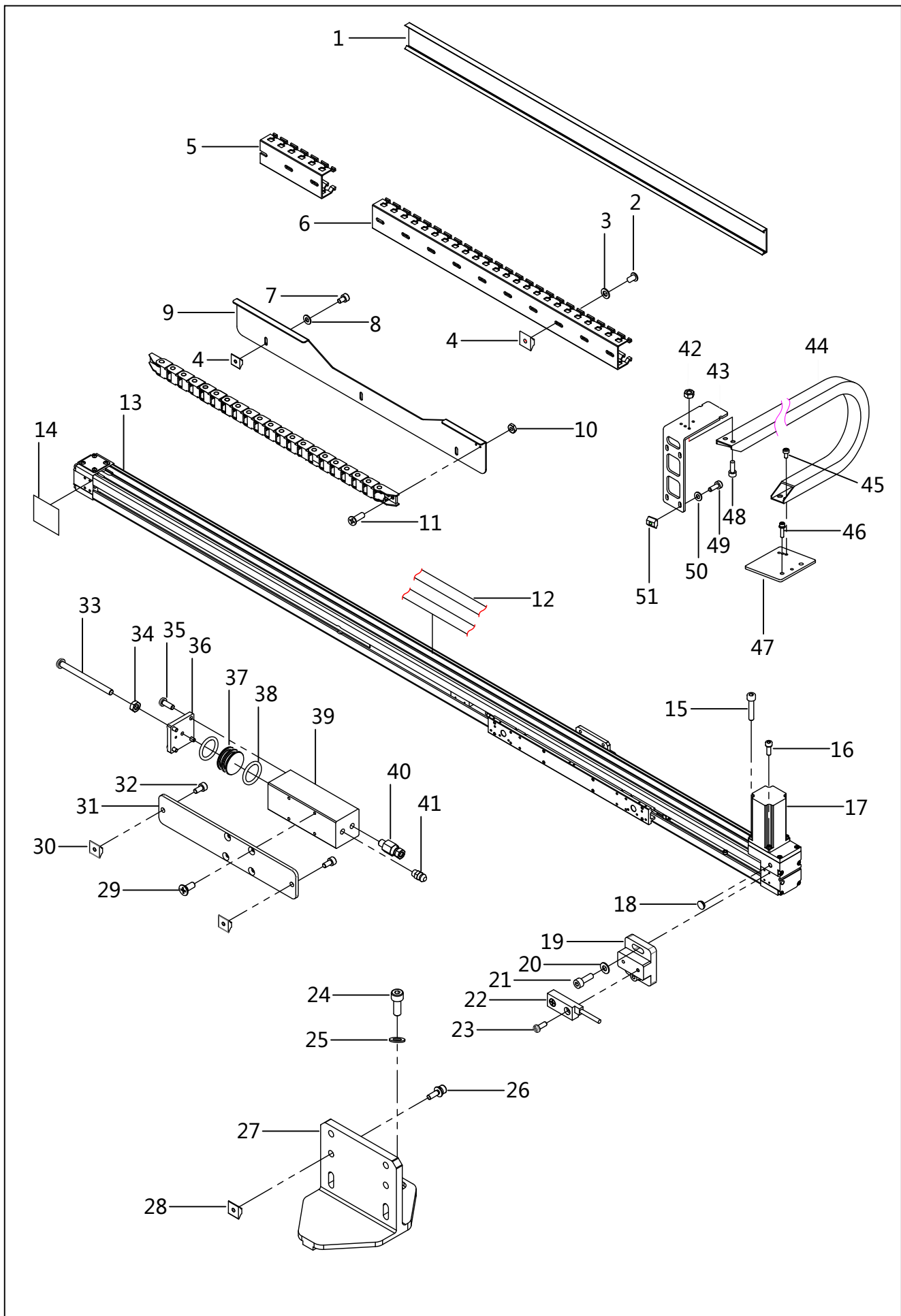

## 6.2、X送料装置(同步带传动) / X Feed mechanism(Screw drive)

序号 Ref.No.	件号 Part.No	对象描述	Description	数量 Amt.	备注 Remarks
29	S02032	螺钉M3×6(镀镍)	SCREW M3X6	4	
30	425S10001	方形螺母块	SQUARE NUT BLOCK	2	
31	141812035	储油脂盒安装板(长)	GREASE STORAGE BOX MOUNTING PLATE(LONG)	1	
32	S05116	螺栓M4×8(滚花,镀镍)(切换)	SCREW M4X8	2	
33	S04125	十字槽盘头螺钉M4/50	SCREW M4X50	1	
34	N01024	六角螺母M4	HEX NUT	1	
35	S04076	螺钉M3X8	SCREW M3X8	4	
36	41812145	储油脂盒盖板	GREASE STORAGE COVER PLATE	1	
37	41842042	活芯子	PISTON	1	
38	41822016	O型圈17×2.65	O-SHAPED RING	2	
39	41842041	Y丝杠储油脂盒	Y LEAD SCREW GREASE STORAGE BOX	1	
40	41836011	铜卡套式直通油管接头M6	COPPER CARD-YYPE DIRECT TUBING JOINT M6	1	
41	41836018	直角油管接头90度M6	LUBRICATING NIPPLE M6	1	
42	407N01002	自锁螺母M4	SELF-LOCKING NUT M4	2	
43	41812141	Y拖链前支架	Y CHAIN BRACKET	1	
44	41811027	塑料拖链1825	PLASTIC DRAG CHAIN 1825	1	
45	S05115	螺栓(带垫圈)M4×6	SCREW M4×6	2	
46	417S30034	螺钉(带垫圈)M4X14	SCREW M4×14	2	
47	41812134	Y拖链后支架	Y DRAG CHAIN LATER SUPPORT	1	
48	422S15501	螺钉M4×10	SCREW M4×10	2	
49	417S30302	螺钉(带垫圈)M4×12	SCREW ( WITH WASHER) M4×12	2	
50	41728024	垫圈L4	GASKET L4	2	
51	425S10001	方形螺母块	SQUARE NUT BLOCK	2	

# 7、送料装置 / Feed mechanism(Screw drive)

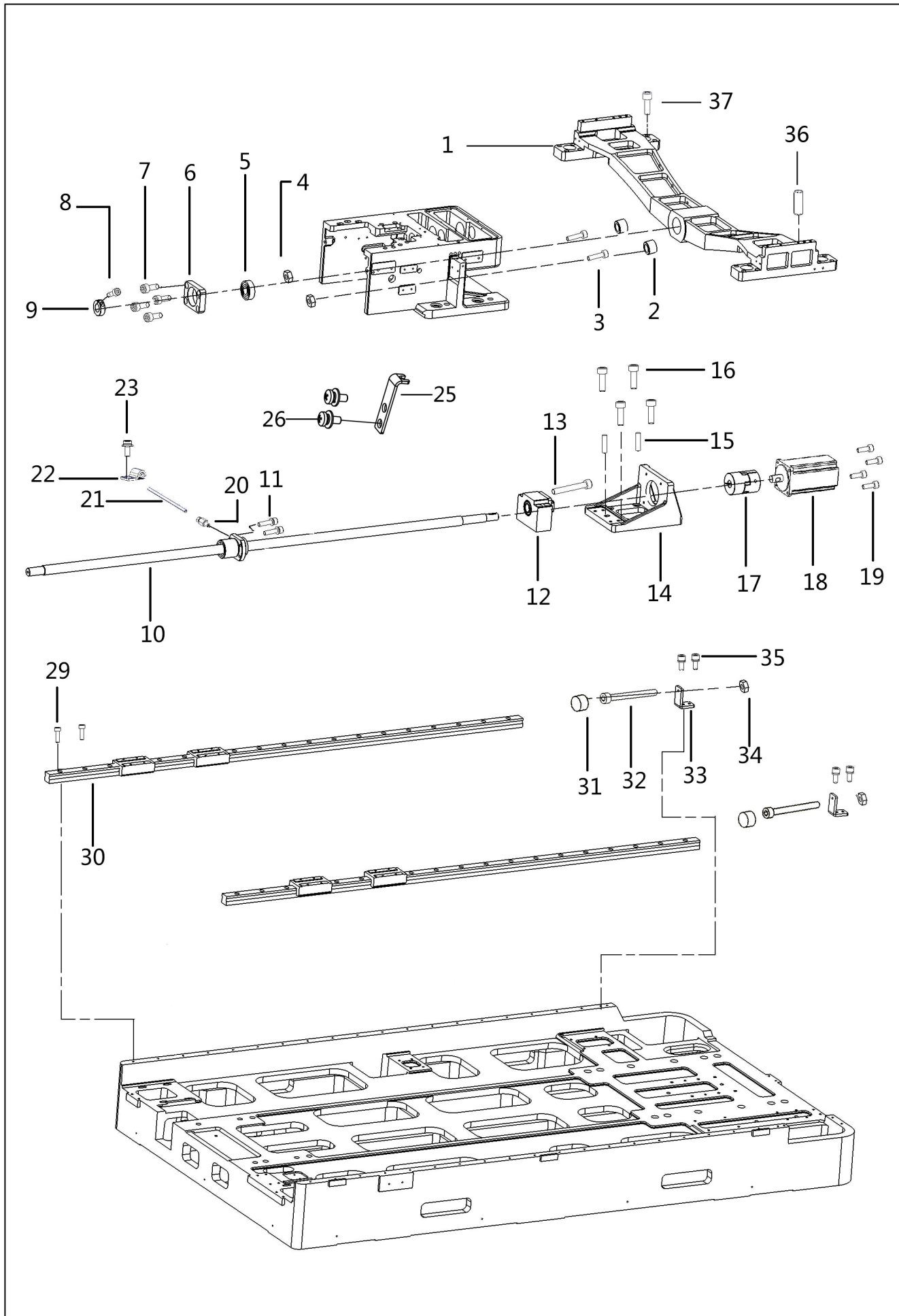

## 7、送料装置(丝杆传动)/Feed mechanism(Screw drive)

序号 Ref.No.	件号 Part.No	对象描述	Description	数量 Amt.	备注 Remarks
1	41801044	Y丝杆同步带驱动座	Y ROD SYNCHRONIZES THE DRIVE SEAT	1	
2	40322021	橡皮塞15	RUBBER CAP 15	2	
3	413S13013	螺栓M6X25	SCREW M6×25	2	
4	N01021	M6螺母	NUT M6	2	
5	B01033	轴承6203	BALL BEARING 6203	1	
6	41801042	Y丝杆支撑端轴承座	Y SCREW SUPPORT BEARING PEDESTAL	1	
7	S05040	螺栓M6×16	SCREW M6×16	4	
8	S05133	螺钉 M4×12(镀镍)	SCREW M4×12	1	
9	41808011	挡圈	CLOSING RING	1	
10	41824015	Y丝杆组件	Y SCREW COMPONENTS	1	
11	421S13059	螺栓 M5×20(滚花,镀镍)	SCREW M5×20	4	
12	41801041	Y丝杆固定端轴承座组件	Y SCREW ROD FIXED END BEARING ASSEMBLY	1	
13	S05139	螺栓M8×55	SCREW M8×55	4	
14	41801040	Y丝杆电机座	SCREW MOTOR STAND	1	
15	41826016	圆柱销8×30	PIN 8×30	2	
16	S05074	螺栓M8×20	SCREW 8×20	4	
17	4180301200	梅花联轴器组件	COMPONENT OF CLUBS COUPLING	1	
18	41833013	Y伺服电机	Y SERVO MOTOR	1	
19	S05040	螺栓M6×16	SCREW M6×16	4	
20	41836011	铜卡套式直通油管接头M6	COPPER CARD-YYPE DIRECT TUBING JOINT M6	1	
21	41821011	油管	OIL TUBE	1	
22	12912326	管夹	PIPE CLAMP	1	
23	417S30025	螺栓M4X10DB	SCREW(WITH SHIM) M4×10DB	1	
25	41812667	油管支架	TUBING SUPPORT	1	
26	417S30025	螺栓(带垫圈)M4×10DB	SCREW M4×20	2	
29	S05124	螺栓 M5×16(滚花,镀镍)	SCREW M5×16	22	
30	41824012	Y导轨	Y GUIDE RAIL	2	
31	40322021	橡皮塞15	RUBBER CAP 15	2	
32	S05088	螺钉M6X45	SCREW M6×45	2	
33	41812028	Y限位板B	Y LOCATION-LIMITED PLATE B	2	
34	N01021	M6螺母	NUT M6	2	
35	417S30036	螺钉M5X12	SCREW M5X12	4	
36	41826011	圆柱销6×15	PIN 6×15	2	
37	S05123	螺钉5X12	SCREW M5X12	16	

## 8、送料装置(夹具C)/Feed mechanism(fixture C)

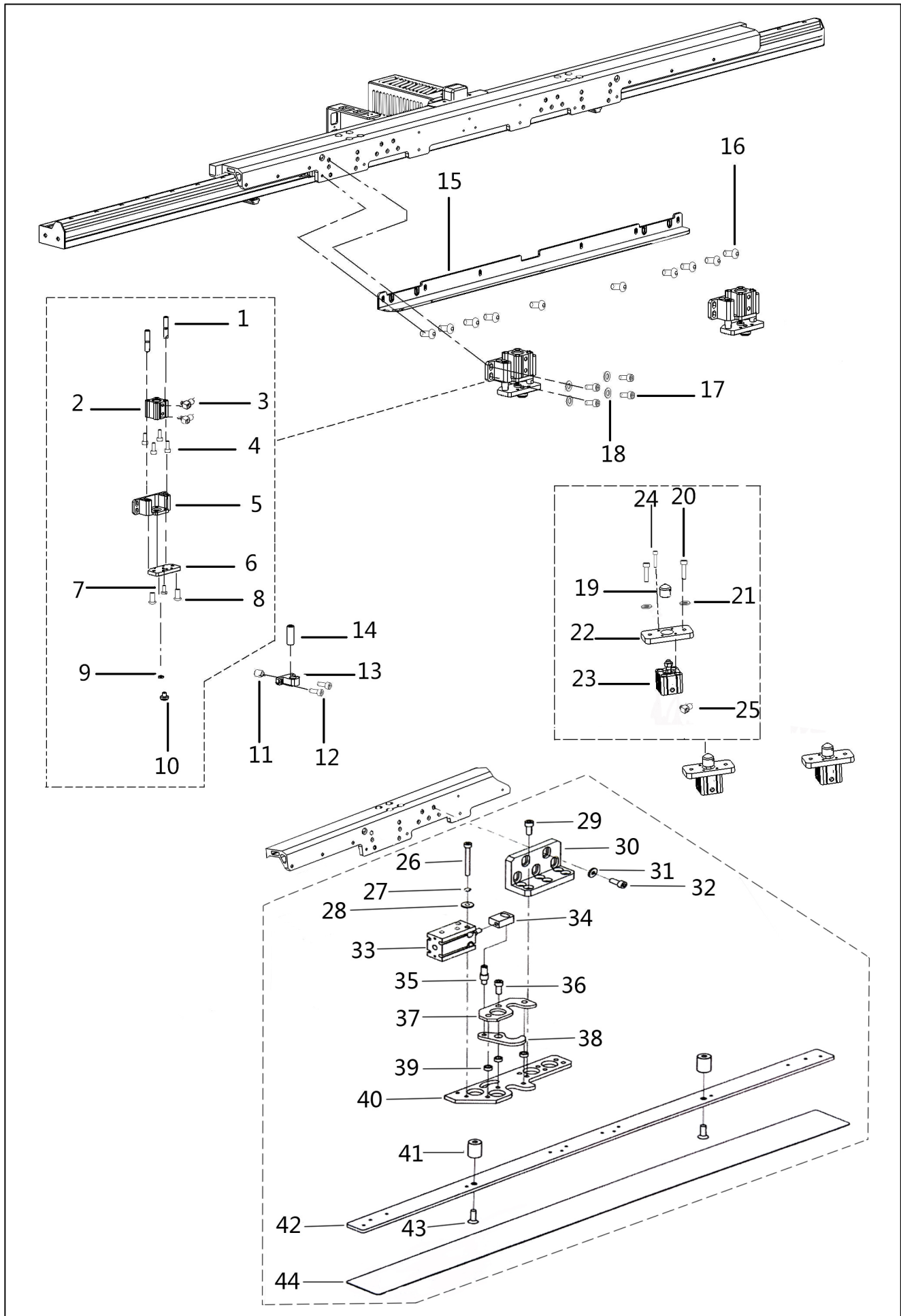

## 8、送料装置(夹具C)/Feed mechanism(fixture C)

序号 Ref.No.	件号 Part.No	对象描述	Description	数量 Amt.	备注 Remarks
1	41826013	导杆Φ8	GUIDE ROD Φ8	4	
2	41845011	气缸CQ2B16-10	AIR CYLINDER CQ2B16-10	2	
3	42230519	微型接头M-5HLH-4	MICRO PIPE CONNECTION M-5HLH-4	4	
4	S05048	螺钉M4×10	SCREW M4X10	8	413S13017
5	41801012	气缸导杆块	AIR CYLINDER GUIDE BAR	2	
6	41812022	模板压板	TEMPLATE LINKING PIECE	2	
7	417S15008	螺栓 M4×8(滚花,镀镍)	SCREW M4X8	2	403S11013
8	S17005	螺钉M5×10(公制圆杯螺丝)	SCREW M5X10	4	
9	41828012	垫圈4	WASHER 4	2	
10	41826014	模板定位锥销	TEMPLATE POSITIONING TAPER PIN	2	
11	S10019	螺钉 M6×6(镀铬)	SCREW M6×6	1	
12	S05048	螺钉 M4×10(镀镍)	SCREW M4×10	2	413S13017
13	41842016	限位销支座	LIMIT PIN SUPPORT	1	
14	41826015	模板限位销	TEMPLATE PIN	1	
15	41842220	托板	PLANKER	1	
16	S17005	螺栓M5X10(公制圆杯螺丝)	SCREW M5×10	10	
17	S05123	螺栓 M5×12(滚花,镀镍)	SCREW M5×12	8	
18	W01009	垫圈5	WASHER 5	8	
19	41842038	顶柱	TOP PILLAR	2	
20	S05068	螺钉M5×20	SCREW M5×20	4	114S13001
21	41728004	垫圈	PIN	4	
22	41842037	顶柱气缸安装板	TOP PILLAR AIR CYLINDER MOUNTING PLATE	2	
23	41830211	气缸CQ2B12-5SM	AIR CYLINDER	2	
24	421S17001	螺钉M4×16	SCREW M4×16	8	
25	42230519	微型接头M-5HLH-4	MICRO PIPE CONNECTION M-5HLH-4	2	
26	S05065	螺钉M4×40	SCREW M4×40	4	
27	W02008	弹簧垫圈2-4	SPRING WASHER 2-4	4	
28	42128003	垫圈	WASHER	4	
29	S05067	螺钉M4×10	SCREW M4×10	12	
30	41842218	夹具联接板B	FIXTURE CONNECTING PIATE B	2	
31	W01009	垫圈5	WASHER 5	10	
32	S05123	螺钉M5×12	SCREW M5×12	10	
33	41730441	气缸CU16-15D	AIR CYLINDER CU16-15D	2	
34	401727	接头	JOINT	2	
35	42226811	接头销	JOINT PIN	2	
36	S05123	螺栓M5×12	SCREW M5×12	6	夹扣式 (选配)
37	42212607	夹紧杆挡板	CLAMPING ROD BAFFLE	2	
38	42212813	夹紧杆	Clamping rod	2	
39	42228811	转动垫圈	ROTARY WASHER	6	
40	42212538	夹具安装板L	FIXTURE MOUNTING PLATE L	2	
41	42226812	夹紧销	CLAMPING PIN	30	
42	42212800	塑料托板	PLASTIC BRACKET	15	
43	417S17852	螺栓M5×15	SCREW M5×15	30	
44	42212820	透明托板	TRANSPARENT PALLET	3	

# 8.1、送料装置(压框夹具S)/Feed mechanism(Clamping fixture S)

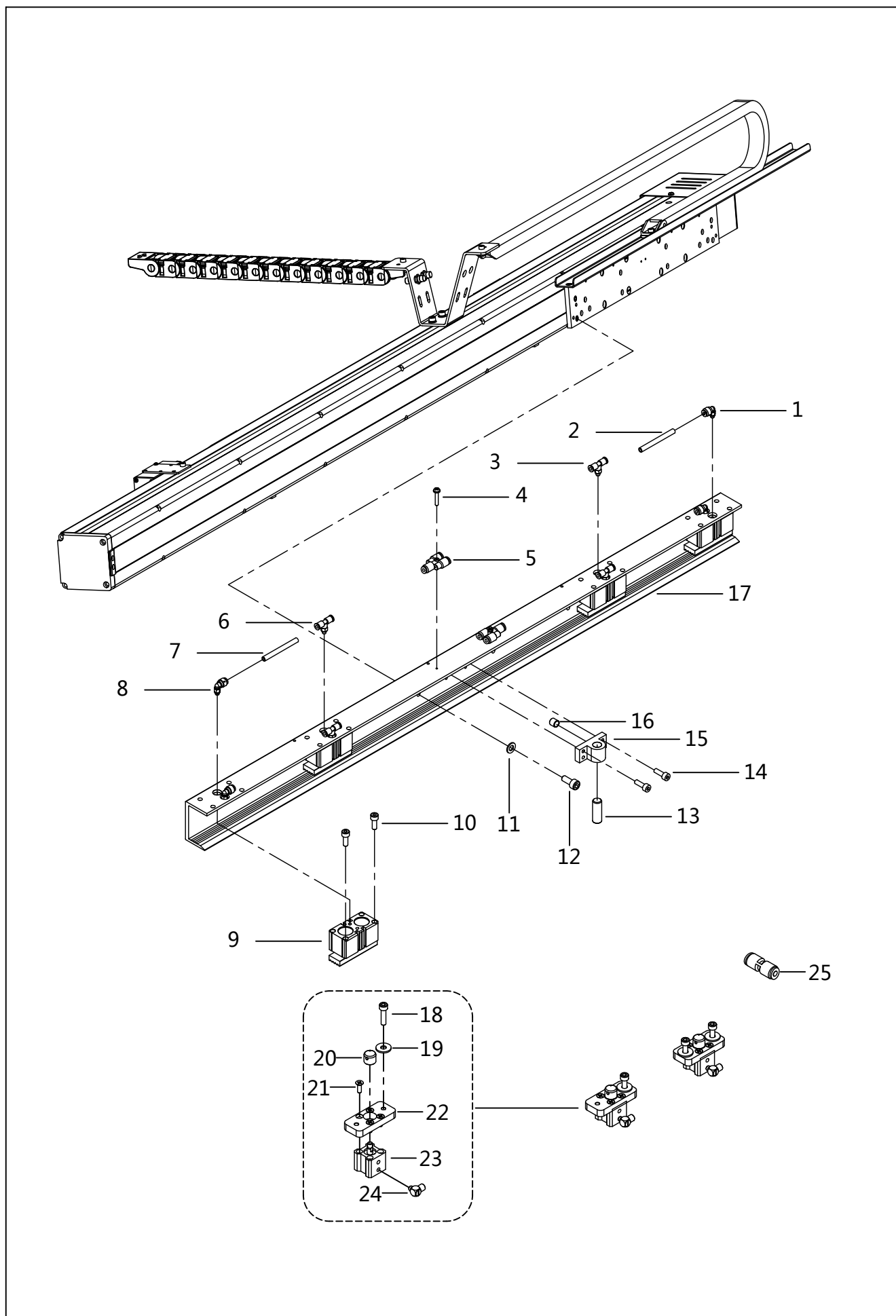

## 8.1、送料装置(压框夹具S)/Feed mechanism(Clamping fixture S)

序号 Ref.No.	件号 Part.No	对象描述	Description	数量 Amt.	备注 Remarks
1	42536004	气管接头(直角)	GES POPE JOINT(90°)	2	
2	41845224	气管φ4×2.5黑色	GES POPE φ4×2.5 ( BLACK )	4.2	
3	42536003	气管接头(三通)	GES POPE JOINT(THREE-WAY PIPE)	2	
4	417S30023	螺钉(带垫圈) M3×16DB	SCREW M3X16DB	2	
5	40736036	气管接头(三通)	GES POPE JOINT(THREE-WAY PIPE)	2	
6	42536003	气管接头(三通)	GES POPE JOINT(THREE-WAY PIPE)	2	
7	41845223	气管φ4×2.5透明蓝	GES POPE φ4×2.5 ( BLUE )	4.2	
8	42536004	气管接头(直角)	GES POPE JOINT(90°)	2	
9	4254500400	气缸	AIR CYLINDER	4	
10	S05124	内六角平头螺钉M5×16	INTERNAL HEXAGONAL FLAT HEAD SCREW M5×20	16	
11	41728028	平垫圈5	PLAIN WASHER 5	8	
12	S05123	内六角平头螺钉M5×12	INTERNAL HEXAGONAL FLAT HEAD SCREW M5×12	8	
13	42526008	限位销	SPACER PIN	1	
14	S05059	内六角平头螺钉M4×12	INTERNAL HEXAGONAL FLAT HEAD SCREW M4×12	4	
15	42512028	限位支座	LIMIT PIN SUPPORT	1	
16	S09019	螺钉M5×6	SCREW M5×6	1	
17	41842502	压框架	COMPRESSION FRAME	1	
18	S05068	螺钉M5×20	SCREW M5×20	4	114S13001
19	41728004	垫圈	PIN	4	
20	41842038	顶柱	TOP PILLAR	2	
21	421S17001	螺钉M4×12	SCREW M4×12	8	
22	41842037	顶柱气缸安装板	TOP PILLAR AIR CYLINDER MOUNTING PLATE	2	
23	41845017	气缸CQ2A12-5SM	AIR CYLINDER	2	
24	42230519	微型接头M-5HLH-4	MICRO PIPE CONNECTION M-5HLH-4	2	
25	41836501	管接头PU4	WEASAND CONNECTOR PU4	1	



## 8.2、送料装置(夹扣夹具S)/Feed mechanism(Clamping fixture S)

序号 Ref.No.	件号 Part.No	对象描述	Description	数量 Amt.	备注 Remarks
1	141845002	三通气管接头(T型)	PIPE CONNECT(THREE-WAY PIPE)	2	
2	407S04053	螺钉M3×25	SCREW M3×25	2	
3	401727	接头	JOINT	2	
4	S05065	螺钉M4×40	SCREW M4×40	4	
5	W02008	弹簧垫圈2-4	SPRING WASHER 2-4	4	
6	42128003	垫圈	PIN	4	
7	42536004	气管接头(直角)	PIPE CONNECT	4	
8	41730441	气缸CU16-15D	AIR CYLINDER CU16-15D	2	
9	42212607	夹紧杆挡板	CLAMPING ROD BAFFLE	2	
10	42212813	夹紧杆	CLAMPING ROD	2	
11	42212538	夹具安装板L	FIXTURE MOUNTING PLATE L	2	
12	42228811	转动垫圈	ROTARY WASHER	6	
13	S05123	螺栓M5×12	BOLT M5×12	6	
14	42226811	接头销	JOINT PIN	2	
15	S05123	螺钉M5×12	SCREW M5×12	10	
16	W01009	垫圈5	WASHER 5	10	
17	41842218	夹具联接板B	FIXTURE CONNECTING PIATE B	2	
18	S05067	螺钉M5×10	SCREW M5×10	12	
19	41845223	气管φ4×2.5透明蓝	GES POPE φ4×2.5 ( BLUE )	4.2	
20	41845224	气管φ4×2.5黑色	GES POPE φ4×2.5 ( BLACK )	4.2	
21	42212800	塑料托板	PLASTIC BRACKET	15	
22	42226812	夹紧销	CLAMPING PIN	30	
23	417S17852	螺栓M5×15	SCREW M5×15	30	
24	42212820	透明托板	TRANSPARENT PALLET	3	
25	41836501	管接头PU4	WEASAND CONNECTOR PU4	2	

### 8.3、送料装置(压框夹具T)/Feed mechanism(Clamping fixture T)

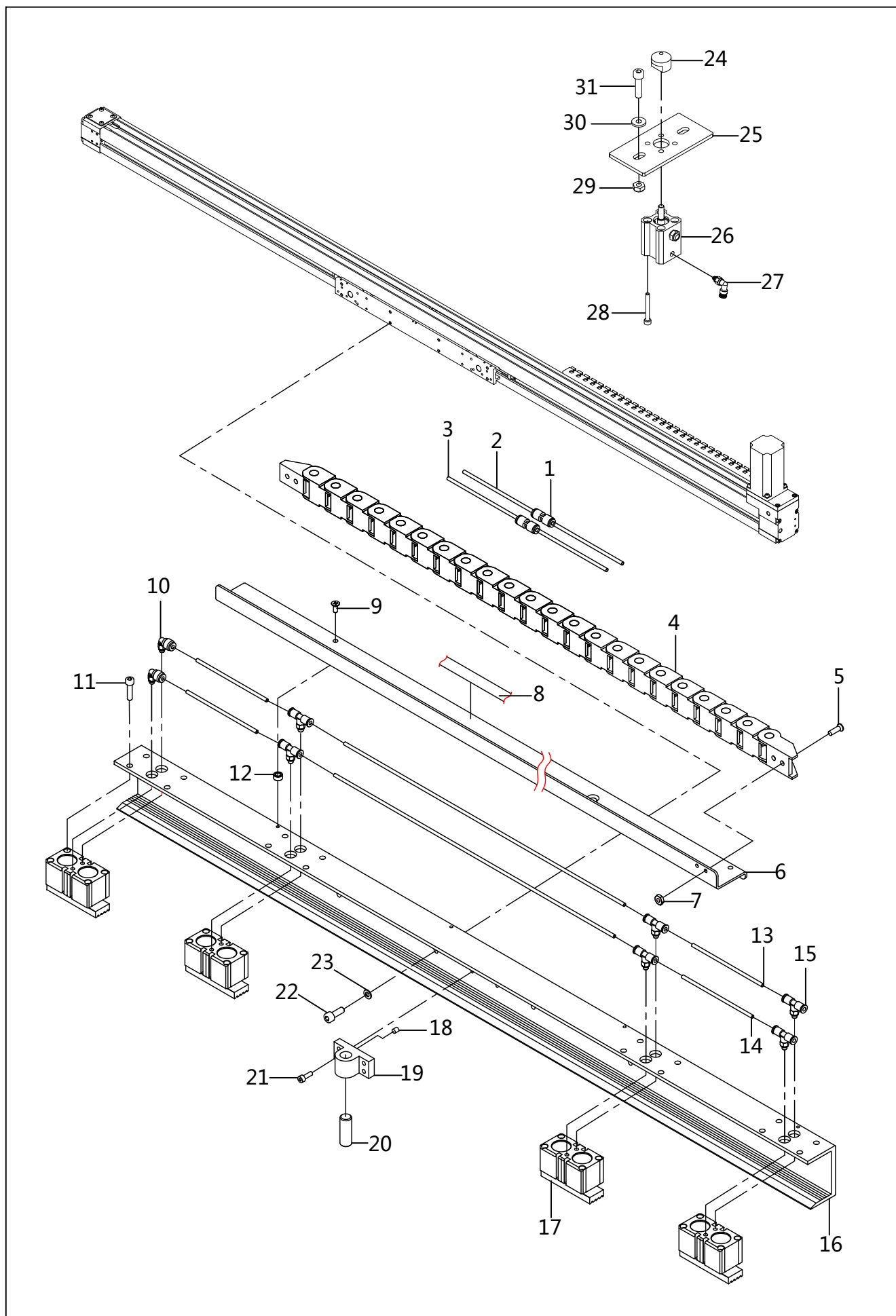

### 8.3、送料装置(压框夹具T)/Feed mechanism(Clamping fixture T)

序号 Ref.No.	件号 Part.No	对象描述	Description	数量 Amt.	备注 Remarks
1	41836501	管接头PU4	WEASAND CONNECTOR PU4	2	
2	41845223	气管φ4×2.5透明蓝	BLUE WEASAND φ4×2.5	1.2	
3	41845224	气管φ4×2.5黑色	BLACK WEASAND φ4×2.5	1.2	
4	41811500	小坦克链	PANZER CHAIN	1	
5	S02127	沉头螺钉M3×10	SCREW M3×10	2	
6	41842504	拖链导板	PANZER CHAIN PLATE	1	
7	N08008	自锁螺母M3	NUT M3	2	
8	141831029	特氟龙胶带0.13×25	TEFLON TAPE 0.13×25	1	
9	407S17001	沉头螺钉M4×10	SCREW M4×10	4	
10	42536004	气管接头	WEASAND CONNECTOR	2	
11	S05124	螺钉M5×16	SCREW M5×16	16	
12	41842503	拖链导板垫块	PANZER CHAIN SHIM	4	
13	41845223	气管φ4×2.5透明蓝	BLUE WEASAND φ4×2.5	1	
14	41845224	气管φ4×2.5黑色	BLACK WEASAND φ4×2.5	1	
15	42536003	气管接头	WEASAND CONNECTOR	6	
16	41842502	压框架	PRESS FRAME	1	
17	4254500400	气缸	CYLINDER	4	
18	S09019	螺钉M5×5	SCREW M5×5	1	
19	42512028	限位支座	LIMIT BEARING	1	
20	42526008	限位销	LIMIT PIN	1	
21	S05059	螺钉M4×12	SCREW M4×12	4	
22	S05124	螺钉M5×16	SCREW M5×16	8	
23	41728028	垫圈5	WASHER 5	8	
24	41826211	顶柱	COLUMN	2	
25	41812258	顶柱气缸安装板	COLUMN CYLINDER PLATE	2	
26	41830211	气缸	CYLINDER	2	
27	42230519	微型接头M-5HLH-4	WEASAND CONNECTOR M-5HLH-4	2	
28	S05215	螺栓M3×26	BOLT M3×26	8	
29	407N01001	自锁螺母M5	SELF LOCKING NUT M5	4	
30	41828612	平垫圈	WASHER	4	
31	S05218	螺钉M5×22	SCREW M5×22	4	

## 8.4、送料装置(夹扣夹具T)/Feed mechanism(Clamping fixture T)

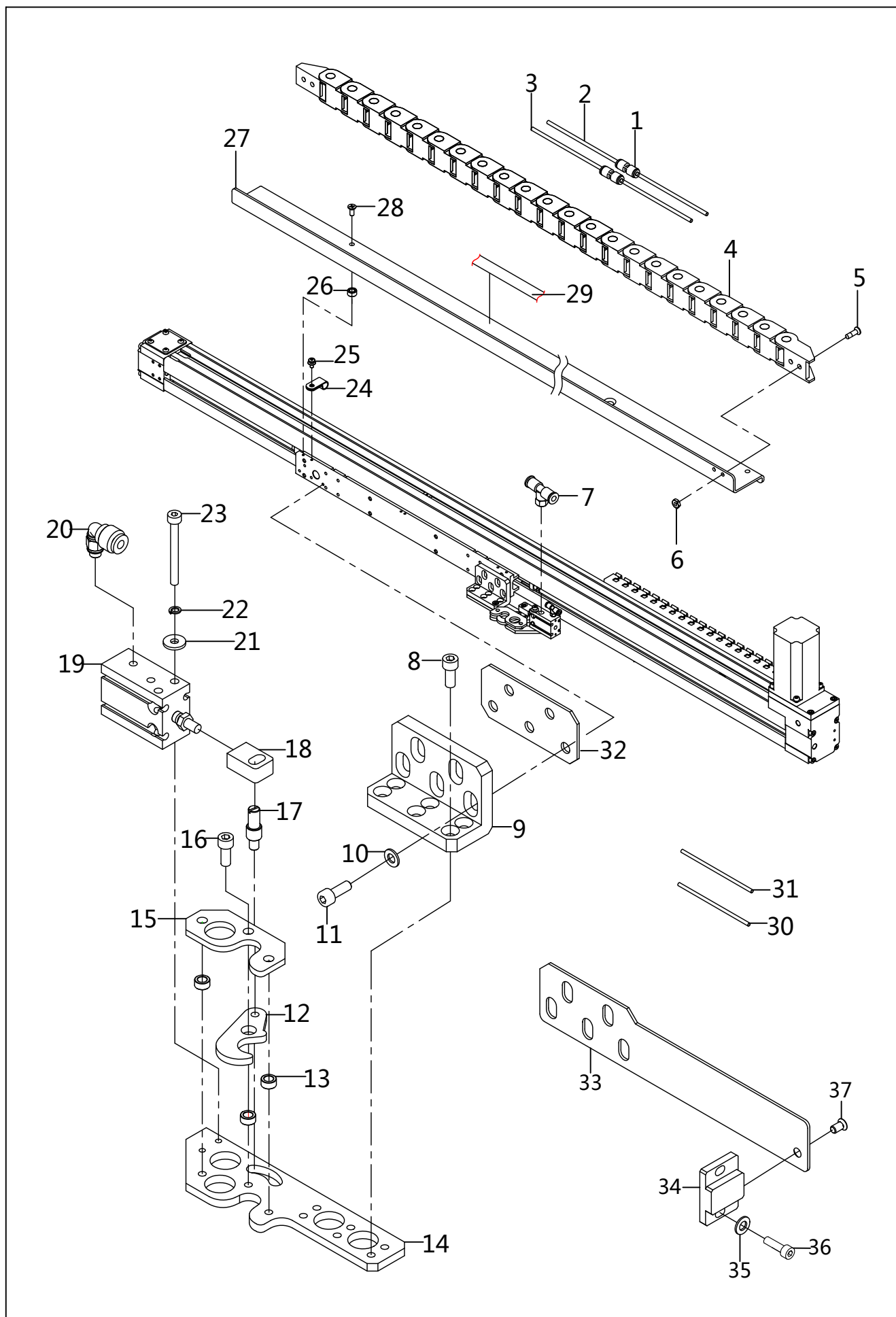

## 8.4、送料装置(夹扣夹具T)/Feed mechanism(Clamping fixture T)

序号 Ref.No.	件号 Part.No	对象描述	Description	数量 Amt.	备注 Remarks
1	41836501	管接头PU4	WEASAND CONECTOR PU4	2	
2	41845223	气管φ4×2.5透明蓝	BLUE WEASAND φ4×2.5	1.2	
3	41845224	气管φ4×2.5黑色	BLACK WEASAND φ4×2.5	1.2	
4	41811500	小坦克链	PANZER CHAIN	1	
5	S02127	沉头螺钉M3×10	SCREW M3×10	2	
6	N08008	自锁螺母M3	NUT M3	2	
7	42536003	气管接头	WEASAND CONNECTOR	2	
8	S05121	螺栓M5×10	BOLT M5×10	12	
9	41842218	夹具连接板B	CLAMP CONNEATION PLATE B	2	
10	W01009	垫圈5	WASHER	8	
11	S05123	螺栓M5×12	BOLT M5×12	8	
12	42212813	夹紧杆	PRESS BAR	2	
13	42228811	转动垫圈	MOVING WASHER	6	
14	42212538	夹具安装板L	CLAMP INSTALLATION BOARD L	2	
15	42212607	夹紧杆挡板	PRESS BAR BAFFLE	2	
16	S05123	螺栓M5×12	BOLT M5×12	6	
17	42226811	接头销	PIN	2	
18	401727	接头	CONNCTER	2	
19	41730441	气缸CU16-15D	CYLINDER CU16-15D	2	
20	42536004	气管接头	WEASAND CONNECTOR	2	
21	42128003	垫圈	WASHER	4	
22	W02008	弹簧垫圈2-4	SPRING WASHER	4	
23	S05065	螺钉M4×40	SCREW M4×40	4	
24	41711014	电线夹6.4	CORD GRIP 6.4	3	
25	417S30025	螺栓(带垫圈)M4×10	BOLT M4×10	3	
26	41842510	夹扣专用垫块	PANZER CHAIN SHIM	3	
27	41842504	拖链导板	PANZER CHAIN PLATE	1	
28	407S04001	沉头螺钉M4×16	SCREW M4×16	3	
29	141831029	特氟龙胶带0.13×25	TEFLON TAPE 0.13×25	1	
30	41845224	气管φ4×2.5黑色	BLUE WEASAND φ4×2.5	1	
31	41845223	气管φ4×2.5透明蓝	BLUE WEASAND φ4×2.5	1	
32	141812049	垫板	FILLER PIECE	1	
33	141812048	夹扣感应片	CLAMP INDUCTOR	1	
34	141842007	支撑座	SUPPORT BLOCK	1	
35	W01001	垫圈4	WASHER4	2	
36	S05116	螺钉M4×8	SCREW M4×8	2	
37	S02039	螺钉M4×9	SCREW M4×9	1	

## 9、抬压脚装置/Work clamp lifter mechanism

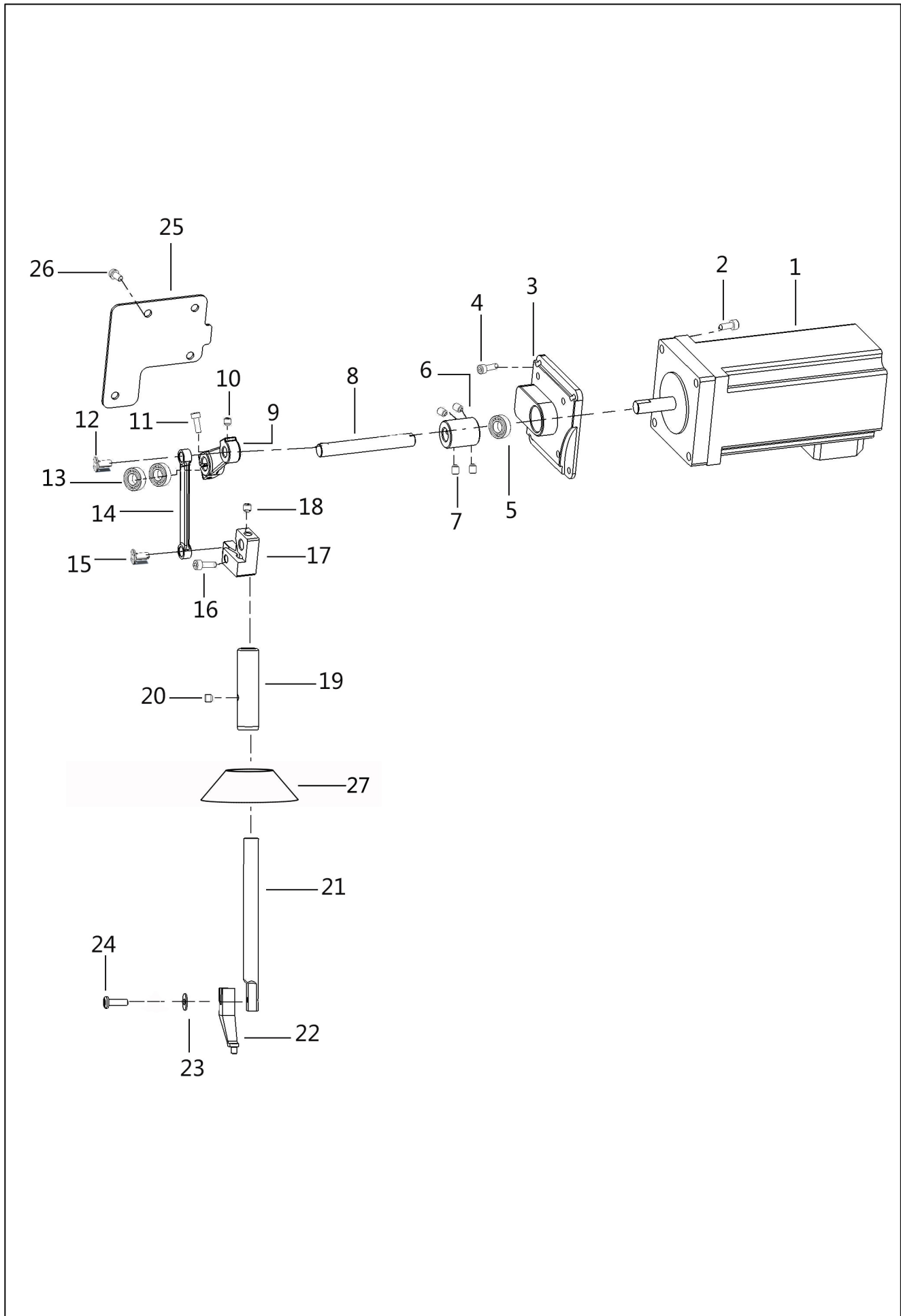

## 9、抬压脚装置/Work clamp lifter mechanism

序号 Ref.No.	件号 Part.No	对象描述	Description	数量 Amt.	备注 Remarks
1	41833213	中压脚电机	MEDIUM PRESSURE FOOT MOTOR	1	
2	S05123	螺栓 M5×12(滚花,镀镍)	SCREW M5×12	4	
3	41801217	中压脚电机安装座	MOTOR MOUNTING PLATE	1	
4	S05124	螺栓 M5×16(滚花,镀镍)	SCREW M5×16	4	
5	B01028	轴承628/8	BEARING 628/8	1	
6	41803228	中压脚电机联轴器	MEDIUM PRESSURE FOOT COUPLING	1	
7	S10019	螺钉 M6X6(镀铬)	SCREW M6×6	4	
8	41802224	中压脚驱动轴	MEDIUM PRESSURE FOOT DRIVE SHAFT	1	
9	41804211	中压脚摇杆	MEDIUM PRESSURE FOOT JOINTED ARM	1	
10	S09019	螺钉 M5×5(镀铬)	SCREW M5×5	1	
11	S05118	螺钉 M4×16(镀镍)	SCREW M4×16	1	
12	41826212	连杆销	LINK PIN	1	
13	B01028	轴承628/8	BALL BEARING 628/8	2	
14	41805212	中压脚连杆	MEDIUM PRESSURE FOOT LINK	1	
15	41826212	连杆销	LINK PIN	1	
16	S05133	螺钉 M4×12(镀镍)	SCREW M4×12	1	
17	41809211	中压脚压杆导架	MEDIUM PRESSURE FOOT PRESSURE ROD GUIDE	1	
18	S09019	螺钉 M5×5(镀铬)	SCREW M5×5	1	
19	41803025	压紧杆轴套	PRESS THE SHAFT SLEEVE	1	
20	S09019	螺钉 M5×5(镀铬)	SCREW M5×5	1	
21	41802228	压紧杆D	PRESS THE SHAFT D	1	
22	42216505	中压脚	MEDIUM PRESSURE FOOT	1	
23	41728025	平垫圈L3.5	FLAT WASHER L3.5	1	
24	417S15011	螺钉SM3.57X12	SCREW SM3.57X12	1	
25	303887	中压脚侧盖 (喷漆)	MEDIUM PRESSURE FOOT SIDE COVER	1	41812259
26	S04028	螺钉M5X8 (镀亮光铬)	SCREW M5X8	4	
27	41822101	橡皮垫	VALVE RUBER	1	

# 10、下轴装置/Lower shaft mechanism

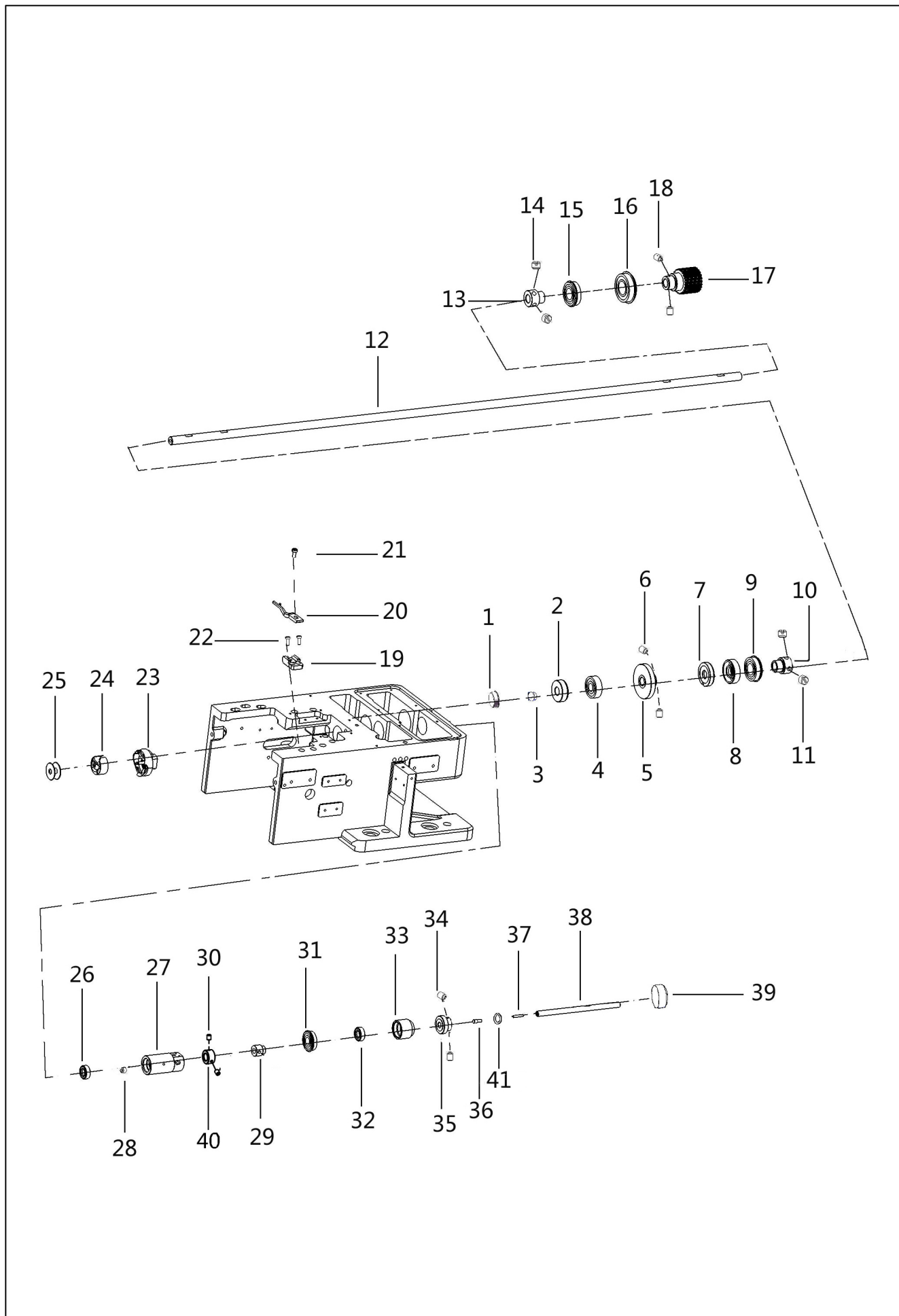

## 10、下轴装置/Lower shaft mechanism

序号 Ref.No.	件号 Part.No	对象描述	Description	数量 Amt.	备注 Remarks
1	14222007	橡皮塞18	RUBBER CAP 18	1	
2	41803012	挡套	SPACER SLEEVE	1	
3	12922001	橡皮塞φ12.5	RUBBER CAP 12.5	1	
4	B10020	轴承 6201ZZNR	BALL BEARING 6201ZZNR	1	
5	1372500100	大齿轮组件	LARGE GEAR ASSEMBLY	1	
6	S10019	螺钉 M6X6(镀铬)	SCREW M6X6	2	
7	13703034	下主动轴油封中套	LOWER DRIVE SHAFT OIL SEAL SLEEVE	1	
8	13722022	抬牙轴油封	LIFT THE SHAFT OIL SEAL	1	
9	B01010	滚针轴承6003	NEEDLE BEARING 6003	1	
10	11403013	轴承套	BEARING SLEEVE	1	
11	101S15002	送料轴挡圈螺钉	SCREW	2	
12	41802016	下同步轮轴	LOWER SYNCHRONOUS WHEEL SHAFT	1	
13	11403013	轴承套	BEARING SLEEVE	1	
14	101S15002	送料轴挡圈螺钉	SCREW	2	
15	B01010	轴承6003	NEEDLE BEARING 6003	1	
16	B10012	轴承 6004DDUNR	NEEDLE BEARING 6004DDUNR	1	
17	41835018	下同步轮	LOWER SYNCHRONOUS WHEEL	1	
18	S10019	螺钉 M6X6(镀铬)	SCREW M6X6	2	
19	41809011	定位勾支座	LOCATING HOOK SUPPORT	1	
20	42212555	旋梭定位勾	SHUTTLE LOCATING HOOK	1	
21	116S11005	牙架曲柄螺钉	SCREW	1	
22	S05048	螺钉 M4×10(镀镍)	SCREW M4×10	2	413S13017
23	41818101	广濑旋梭组件HSM-B1HTR(1Q)	HOOKING COMPONENT	1	
	41818201	旋梭组件DSH2-BTR(JKMBJ)	HOOKING COMPONENT	1	德盛(含梭芯组件)
24	42218002	梭芯套组件	SPINDLE SLEEVE ASSEMBLY	1	
25	10818501	梭心605.609大梭心	BIG BOBBIN	1	
26	41822011	油封0820	OIL SEAL 0820	1	
27	41803023	下轴柱塞轴套	LOWER SHAFT PLUNGER SLEEVE	1	
28	S09006	螺钉M4X4	SCREW M4X4	1	
29	11403016	下轴轴承套	LOWER SHAFT BEARING SLEEVE	1	
30	113S14002	螺钉	SCREW	2	113S14020
31	B02006	轴承6001	BEEL BEARING	1	
32	1142201400	油封组件	OIL SEAL COMPONENT	1	
33	41803015	下轴中轴套	SHAFT SLEEVE IN THE LOWER SHAFT	1	
34	S10019	螺钉 M6X6(镀铬)	SCREW M6X6	2	
35	41825011	斜齿轮	BEVEL WHEEL	1	
36	141803006	下轴油芯套	LOWER SHAGT OIL CORE SLEEVE	1	
37	141823001	下轴限油芯	LOWER SHAGT OIL LIMITING CORE	1	
38	41802017	下轴C	LOWER SHAFT	1	
39	41822015	橡皮塞φ27	RUBBER CAP φ27	1	
40	42508003	挑线连杆销紧圈	SHRINK RING	1	
41	141822002	O形圈3.6×0.8	O-ring	1	

# 11、供油润滑装置/Lubrication mechanism

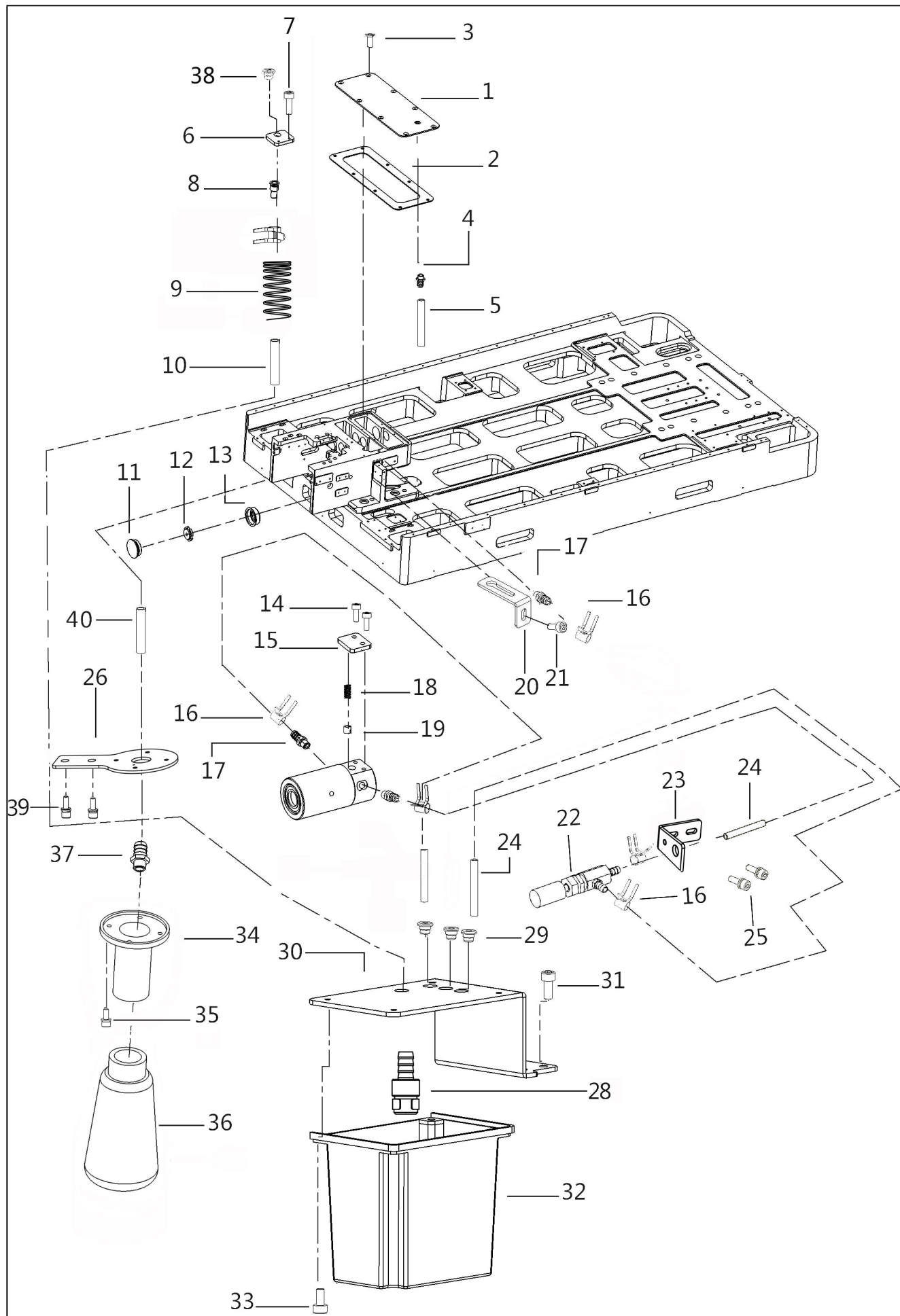

## 11、供油润滑装置/Lubrication mechanism

序号 Ref.No.	件号 Part.No	对象描述	Description	数量 Amt.	备注 Remarks
1	4181203600	齿轮箱盖板组件	GEARBOX COVRE PLATE ASSEMBLY	1	
2	41812035	齿轮箱盖垫板	GEARBOX COVRE PLATE	1	
3	S02039	螺钉 M4×9(镀镍)	SCREW M4×9	8	
4	41736303	油管嘴B	OIL TUBE MOUTH B	1	
5	12921005	油管φ4Xφ6 ( 0.05m)	OIL TUBE φ4Xφ6 ( 0.05m)	1	
6	41812011	加油口安装板	OIL FILLER MOUNTING PLATE	1	
7	S05133	螺钉M4X12	SCREW M4×12	2	
8	13121001	加油口	OIL FILLER	1	
9	41827424	油管护套弹簧	TUBING SHEATH SPRING	1	
10	11421006	油管φ8Xφ10(0.3m)	OIL TUBE φ8Xφ10(0.3m)	1	
11	41711004	油窗盖	OIL WINDOW	1	
12	41711022	挡片	SEPARATION BLADE	1	
13	41722031	橡胶圈	RUBBER RING	1	
14	S05094	螺钉M3X8	SCREW M3X8	2	
15	41812093	柱塞弹簧压板	PLUNGER SPRING CLAMP	1	
16	11412055	φ5.7油管卡簧	φ5.7 TUBING CIRCLIP	4	
17	41836015	油管嘴M5	OIL TUBE MOUTH M5	3	
18	11427021	柱塞弹簧	PLUNGER SPRING	1	
19	10526003	柱塞	PLUNGER	1	
20	41812043	油管支架	OIL TUBE SUPPORT	1	
21	S05048	螺钉M4×10	SCREW M4×10	1	413S13017
22	42236513	调节阀	REGULATING VALVE	2	
23	41812042	油量调节阀安装板	OIL CONTROL VALVE MOUNTING PLATE	1	
24	12921002	维尼龙油管 ( φ3xφ5 )	VINYLON TUBING ( φ3xφ5 )	2	
25	417S30302	螺栓M4X12DB	SCREW(WITH WASHER) M4X12DB	2	
26	41812014	废油壶安装板	AFTER OIL CAN MOUNTING PLATE	1	
28	4183601700	滤网组件	FILTER UNIT	1	
29	40322027	橡皮塞	RUBBER CAP	3	
30	41812012	油杯安装板	OIL CUP MOUNTING PLATE	1	
31	417S30037	螺栓 M6×14(滚花,镀镍)	SCREW M6×14	4	
32	41811228	油杯	OIL CUP	1	
33	S05121	螺栓M5X10	SCREW M5X10	4	
34	40311010	油壶接头	OILER JOINT	1	
35	S05192	螺栓M3X6	SCREW M3X6	4	
36	40311011	接油壶	AFTER OIL CAN	1	
37	12936004	油嘴管	NOZZLE TUBE	1	
38	41722003	橡皮塞10.5	RUBBER CAP 10.5	1	
39	417S30306	螺钉M5×15	SCREW M5×15	2	
40	12921006	维尼龙油管 ( φ6xφ8 )	VINYLON TUBING ( φ6xφ8 )	0.3m	

## 12、穿线装置/Threading mechanism

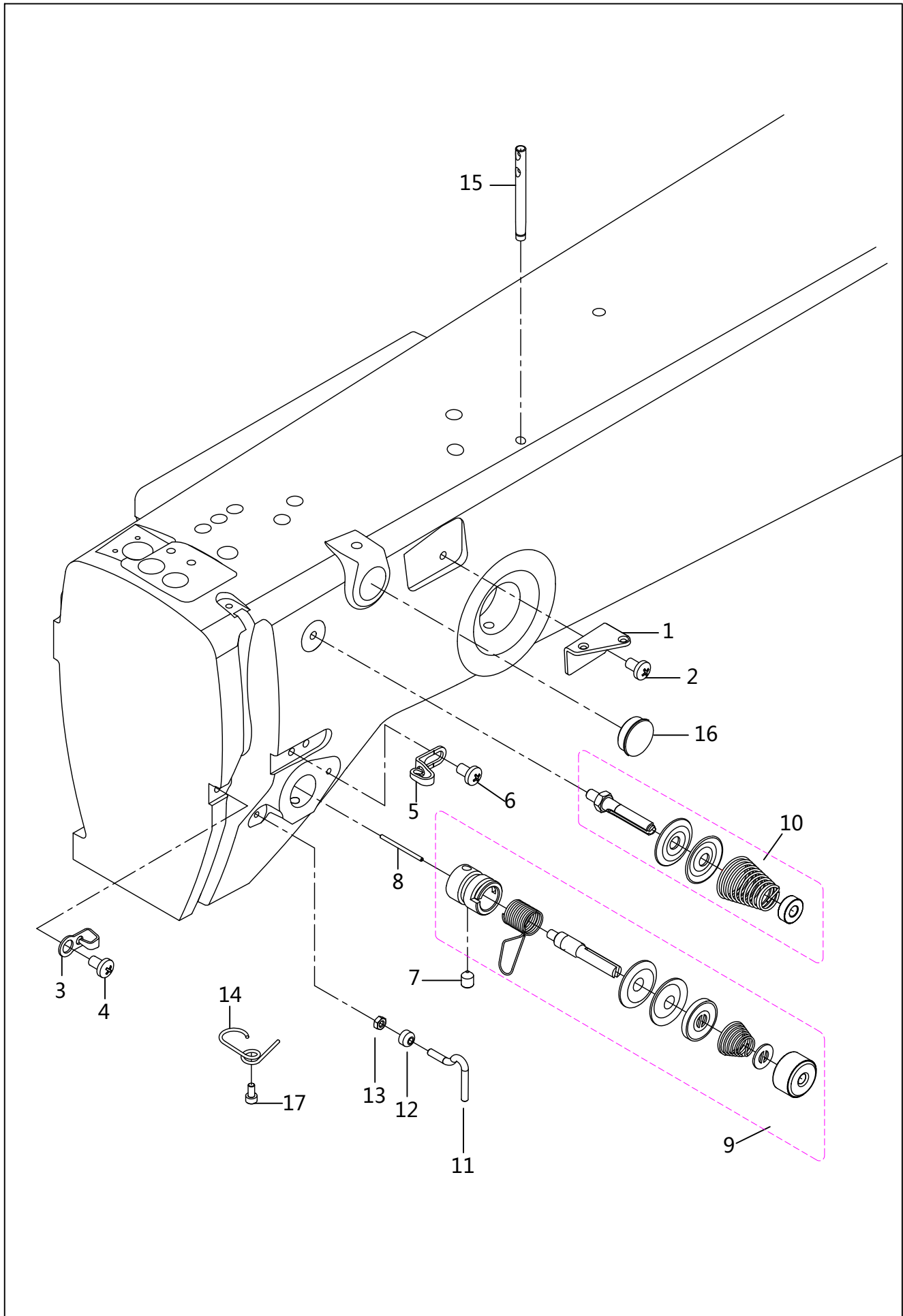

## 12、穿线装置/Threading mechanism

序号 Ref.No.	件号 Part.No	对象描述	Description	数量 Amt.	备注 Remarks
1	41712077	过线导向 A	THE THREAD GUIDE A	1	
2	S04028	螺钉 M5×8(镀亮光铬)	SCREW M5×8	1	
3	41712078	过线导向 B	THE THREAD GUID B	1	
4	S04028	螺钉 M5×8(镀亮光铬)	SCREW M5×8	1	
5	41712079	过线器 C	A THREAD C	1	
6	S04028	螺钉 M5×8(镀亮光铬)	SCREW M5×8	1	
7	S12001	尖端紧定螺钉 M6×8	SCREW M6×8	1	
8	41702031	松线销	LOOSE THREAD PIN	1	
9	4181361200	主夹线器组件	THE MAIN BINDER COMPONENT	1	4221350200
10	4171301400	副夹线器组件	ACCESSORY WIRE HOLDER ASSEMBLY	1	
11	41713301	机壳线钩	CASING THREAD HOOK	1	
12	41722320	减震橡皮	DAMPING RUBBER	1	
13	N01024	六角螺母 M4(厚度2.2,镀镍)	HEX NUT	1	
14	41813622	过线导向弹簧	ARM THREAD GUIDE SPRING	1	
15	41313013	过线轴	A SPOOL	1	
16	14222007	橡皮塞18	RUBBER CAP 18	1	
17	421S13012	螺钉(带垫)M4x10	BOLT (with washer) M4×10	1	

# 13、卷线装置/Bobbin winder mechanism

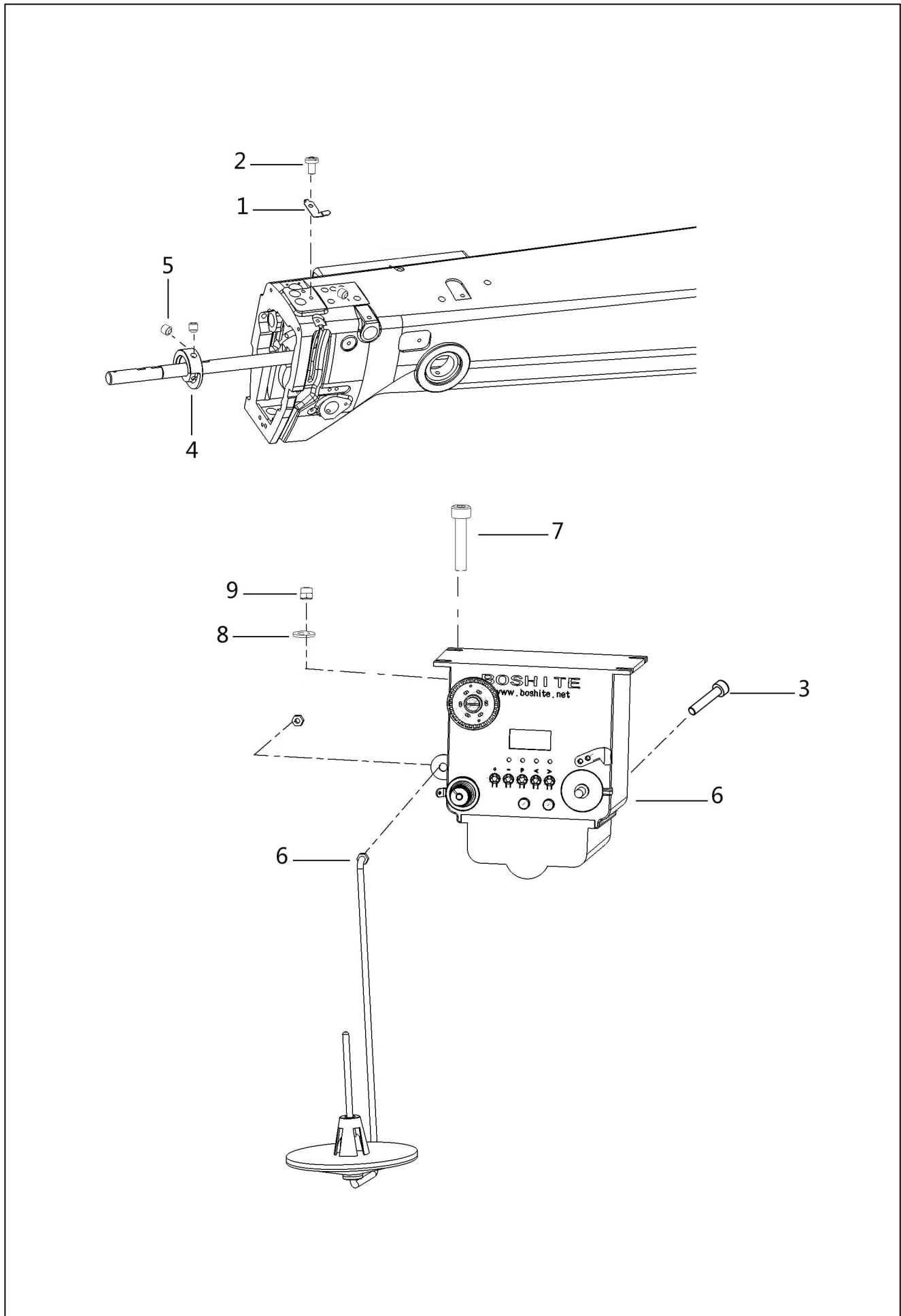

### 13、卷线装置/Bobbin winder mechanism

序号 Ref.No.	件号 Part.No	对象描述	Description	数量 Amt.	备注 Remarks
1	41719001	切刀	CUTTER	1	
2	S04028	螺钉 M5×8(镀亮光铬)	SCREW M5×8	1	
3	S05119	螺栓M4×20(滚花,镀镍)	SCREW M4×20	4	
4	41803219	卷线驱动轮	REEL DRIVING WHEEL	1	
5	S09019	螺钉 M5×5(镀铬)	SCREW M5×5	2	
6	41831222	自动绕线器BOSHITE	AUTOMATIC WINDER	1	
7	S05035	M5×25螺钉	SCREW M5×25	4	
8	407N01001	自锁螺母M5	SELF-LOCKING NUT	4	
9	41728028	垫片M5	GASKET	4	

# 14、切线装置/Thread trimmer mechanism

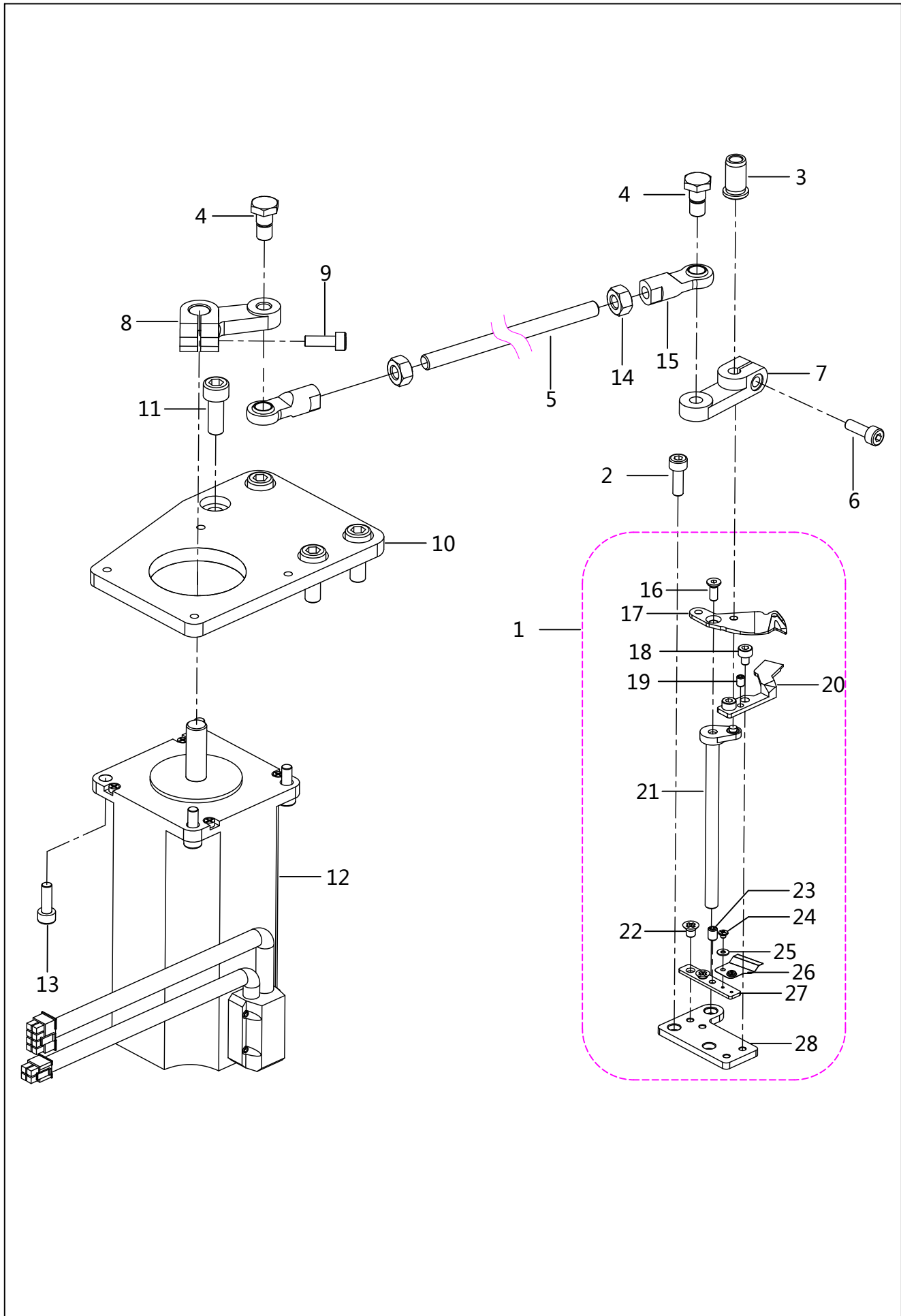

## 14、切线装置/Thread trimmer mechanism

序号 Ref.No.	件号 Part.No	对象描述	Description	数量 Amt.	备注 Remarks
1	4181901100	切刀组件	KNIFE COMPONENTS	1	标准件
2	S05010	螺钉 M4×12(镀镍)	SCREW M4×12	2	
3	41803017	轴套0508	SHAFT SLEEVE 0508	1	
4	417S12005	段螺钉B M6	SCREW M6	2	
5	41802021	切线连杆	TANGENT CONNENTING ROD	1	
6	S05010	螺钉 M4×12(镀镍)	SCREW M4×12	1	
7	41804022	切线摆杆	TANGENT OSCILLATING BAR	1	
8	41804021	切线驱动摆杆	TANGENT DRIVE OSCILLATING BAR	1	
9	S05010	螺栓 M4×12(镀镍)	SCREW M4×12	1	
10	41812044	切线电机安装板	TANGENT MOTOR MOUNTING PLATE	1	
11	S05040	螺栓M6×16	SCREW M6×16	4	
12	42230534	切线电机	TANGENT MOTOR	1	
13	S05010	螺钉 M4×12(镀镍)	SCREW M4×12	4	
14	4170500300	接头组件	ADAPTER ASSEMBLY	2	
15	N01021	螺母M6	NUT M6	2	
16	407S04002	内六角沉头螺钉M3×8	SCREW M3×8	1	
17	41819015	动刀	MOVING BLADE	1	
18	S05047	内六角螺钉M3×4	SCREW M3×4	2	
19	S09042	螺钉M3×4	SCREW M3×4	1	
20	41819016	定刀	STATIONARY KNIFE	1	
21	41819020	动刀杆	MOVING BLADE ROD	1	
22	4181901100-03	十字槽沉头螺钉M3×4	SCREW M3×4	2	
23	S09042	螺钉M3×4	SCREW M3×4	1	
24	4181901100-01	十字槽盘头螺钉M1.6×1.5	SCREW M1.6×1.5	2	
25	4181901100-02	垫片	WASHER	2	
26	41812519	压线片	WIRE SHEET	1	
27	41812518	压线片安装板	WIRE SHEET MOUNTING PLATE	1	
28	41812517	定刀安装板	STATIONARY KNIFE MOUNTING PLATE	1	

## 15、挡线部件/Stop line components

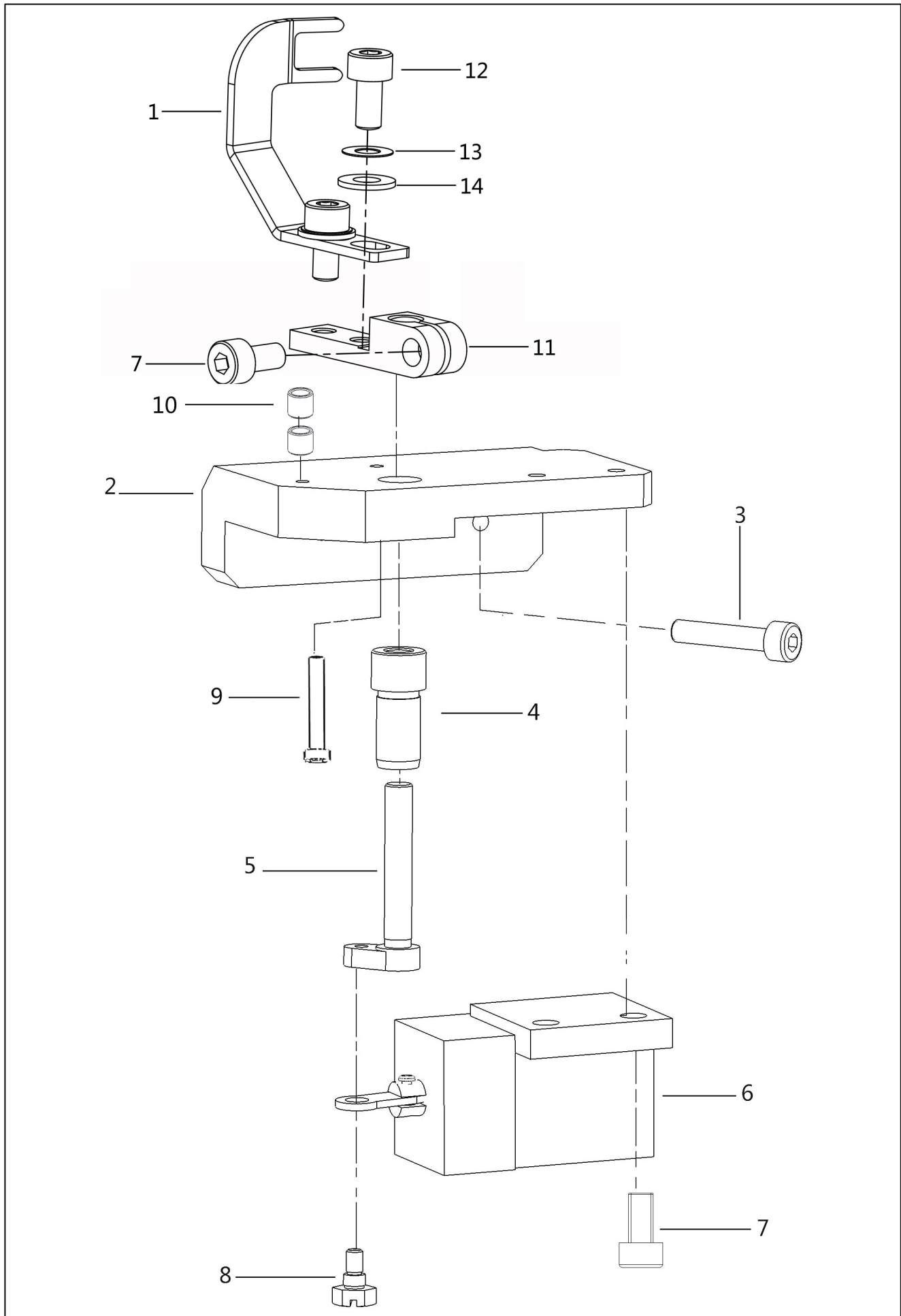

## 15、挡线部件/Stop line components

序号 Ref.No.	件号 Part.No	对象描述	Description	数量 Amt.	备注 Remarks
1	41812094	扣线叉窄	BUCKLE LINE FORK WIDTH	1	
2	41842036	挡线安装板	STOP LINE MOUNTING PLATE	1	
3	S05119	螺钉M4X20	SCREW M4X20	2	
4	41803021	长轴套0508	LONG SHAFT SLEEVE 0508	1	
5	41804014	挡线曲柄	STOP LINE CRANK	1	
6	41830013	挡线电磁铁	STOP LINE ELECTROMAGNET	1	配套
6	41812087	挡线驱动连杆	STOP LINE DRIVE CONNENTING ROD	1	
6	418S30015	螺销	SCREW PIN	1	
7	S05116	螺栓 M4×8(滚花,镀镍)	SCREW M4X8	3	
8	418S20012	轴位螺钉M3	AXIS OF A SCREW M3	1	
9	S05215	螺钉M3X25	SCREW M3X25	1	
10	41811014	偏心限位套	PARTIALITY STOP COLLAR	2	
11	41804015	挡线支架	STOP LINE SUPPORT	1	
12	413S13016	螺钉M4×8	SCREW M4X8	2	
13	W02015	垫片	FLAT GASKET	2	
14	W01097	平垫圈4	FLAT GASKET 4	2	

# 16、扫线装置/Thread wiper mechanism

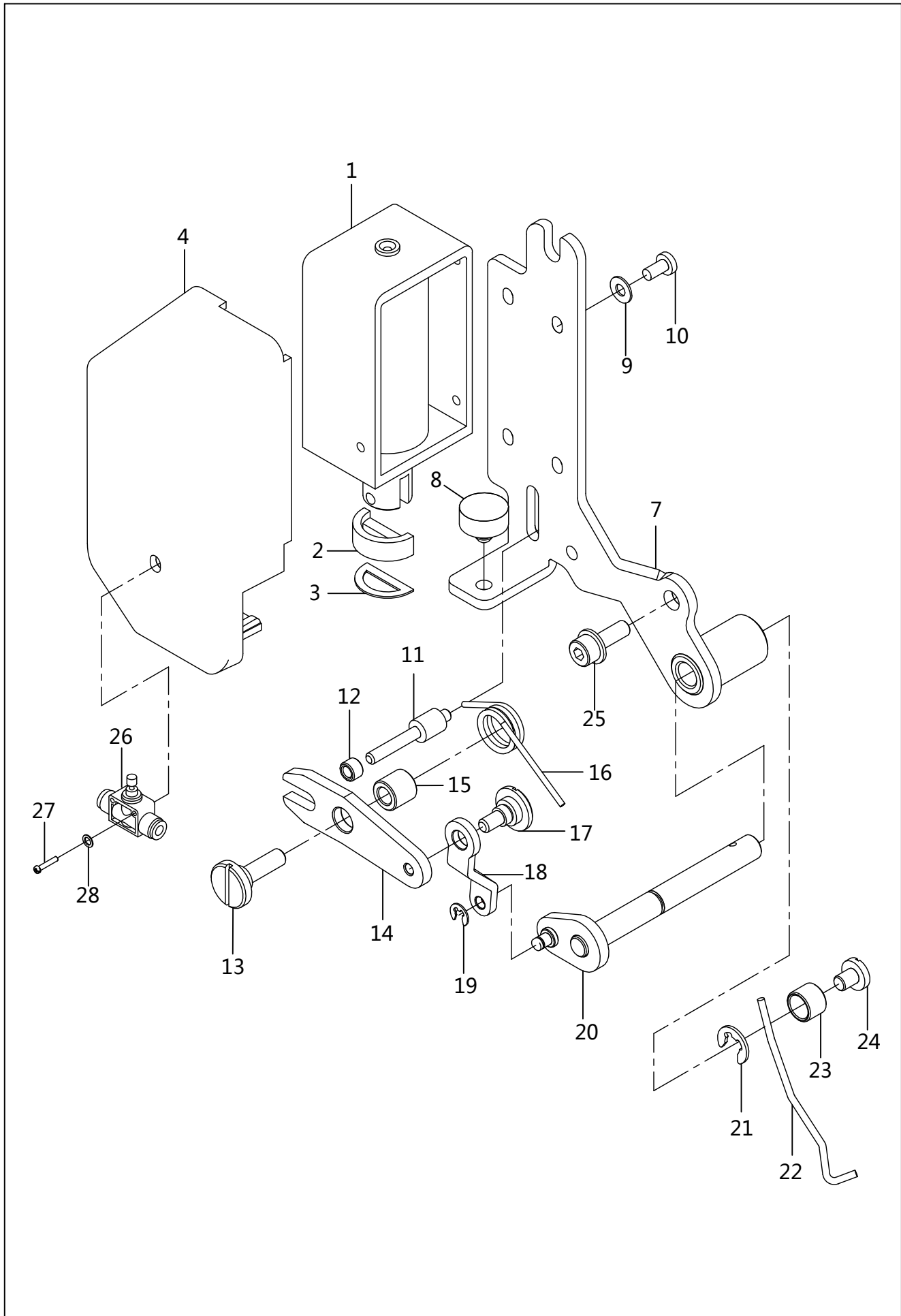

## 16、扫线装置/Thread wiper mechanism

序号 Ref.No.	件号 Part.No	对象描述	Description	数量 Amt.	备注 Remarks
1	41830217	扫线电磁铁	Sweeping electromagnet	1	
2	41822212	D形缓冲垫	D-shape cushion	1	
3	41828212	D形垫圈	D-shape washer	1	
4	41811213	电磁铁盖	Electromagnet cover	1	
6	W01002	M3垫片	M3 washer	1	
7	4181226100	扫线电磁铁安装板组件	Mounting plate component	1	
8	41822213	缓冲块	Buffer block	1	
9	W01002	M3垫片	M3 washer	4	
10	S04082	螺钉M3×6	Screw M3×6	4	
11	41826215	销子	Pin	1	
12	41803223	铜垫圈	Copper washer	1	
13	418S20213	轴位螺钉B	Head screw B	1	
14	41812264	驱动摆杆	Drive swinging rod	1	
15	41803225	套管	Casing tube	1	
16	41827212	扭簧	Torsional spring	1	
17	418S20212	轴位螺钉A	Head screw A	1	
18	41812235	扫线连杆	Sweeping connection rod	1	
19	H03057	开口挡圈3	Split washer 3	1	
20	4180421400	扫线曲柄组件	Sweeping crank component	1	
21	H05006	挡圈5	washer 5	1	
22	41827211	扫线钢丝	Sweeping steel wire	1	
23	41803220	挡线轴挡圈	Spool washer	1	
24	417S15013	螺钉M4×5	Screw M4×5	1	
25	417S30302	螺栓(带垫圈)M4×12	Bolt (with washer) M4×12	2	
26	41845232	T形接管KJT04	T-pipe coupling	1	
27	S01591	螺钉M3×18	Screw M3×18	1	
28	W01002	M3垫片	M3 washer	1	

# 17、松线装置/Tension release mechanism

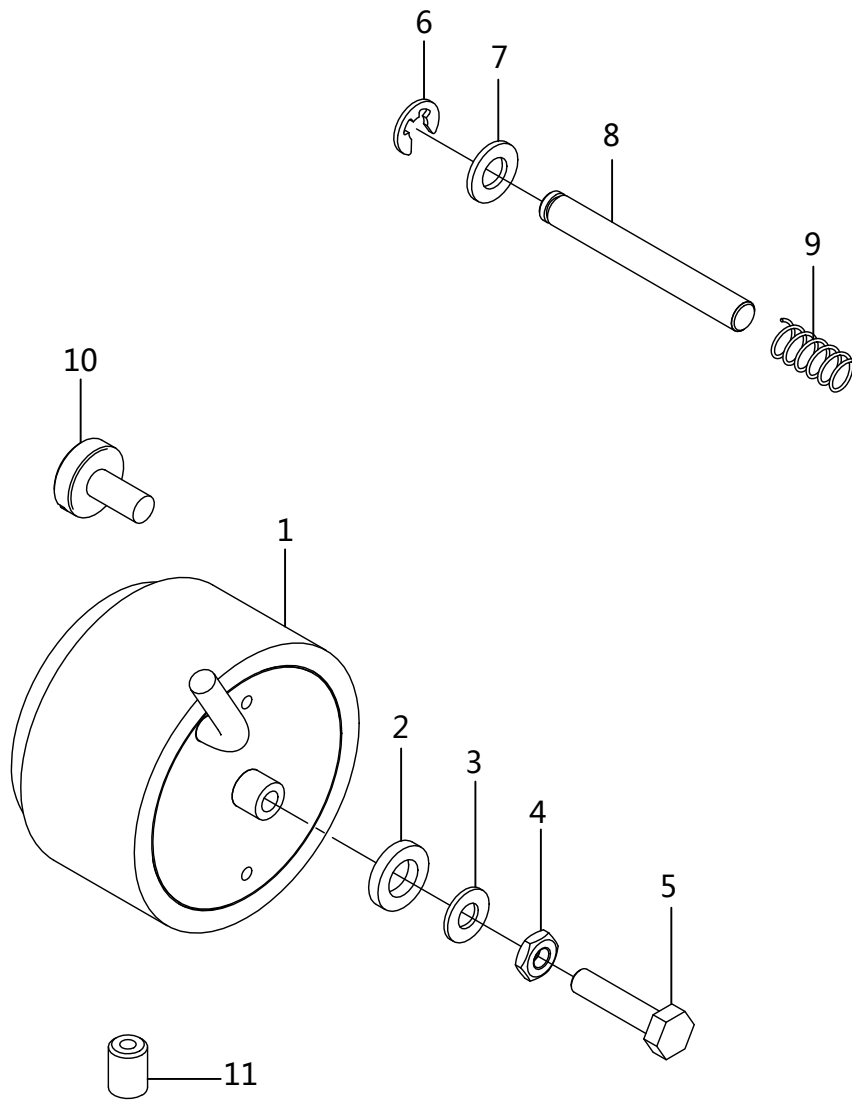

## 17、松线装置/Tension release mechanism

序号 Ref.No.	件号 Part.No	对象描述	Description	数量 Amt.	备注 Remarks
1	41830464	松线电磁铁HV	Thread-loosing electromagnet HV	1	
2	41722020	缓冲垫圈	Buffering washer	1	
3	W01001	M4垫片	M4 gasket	1	
4	N01024	六角螺母M4	Hex nut M4	1	
5	L02071	六角头螺栓M4×18	Hex head bolt M4×18	1	
6	H05029	挡圈E4	Retainer ring E4	1	
7	W01009	垫圈5	Washer 5	1	
8	41826220	松线杆	Thread-loosing rod	1	
9	41727013	弹簧	Spring	1	
10	114S11003	螺钉3/16-28 L=10	Screw 3/16-28 L=10	2	
11	S10009	凹端紧定螺钉M6×8	Concave set screw M6×8	1	

# 18、大压脚装置/External work clamp mechanism

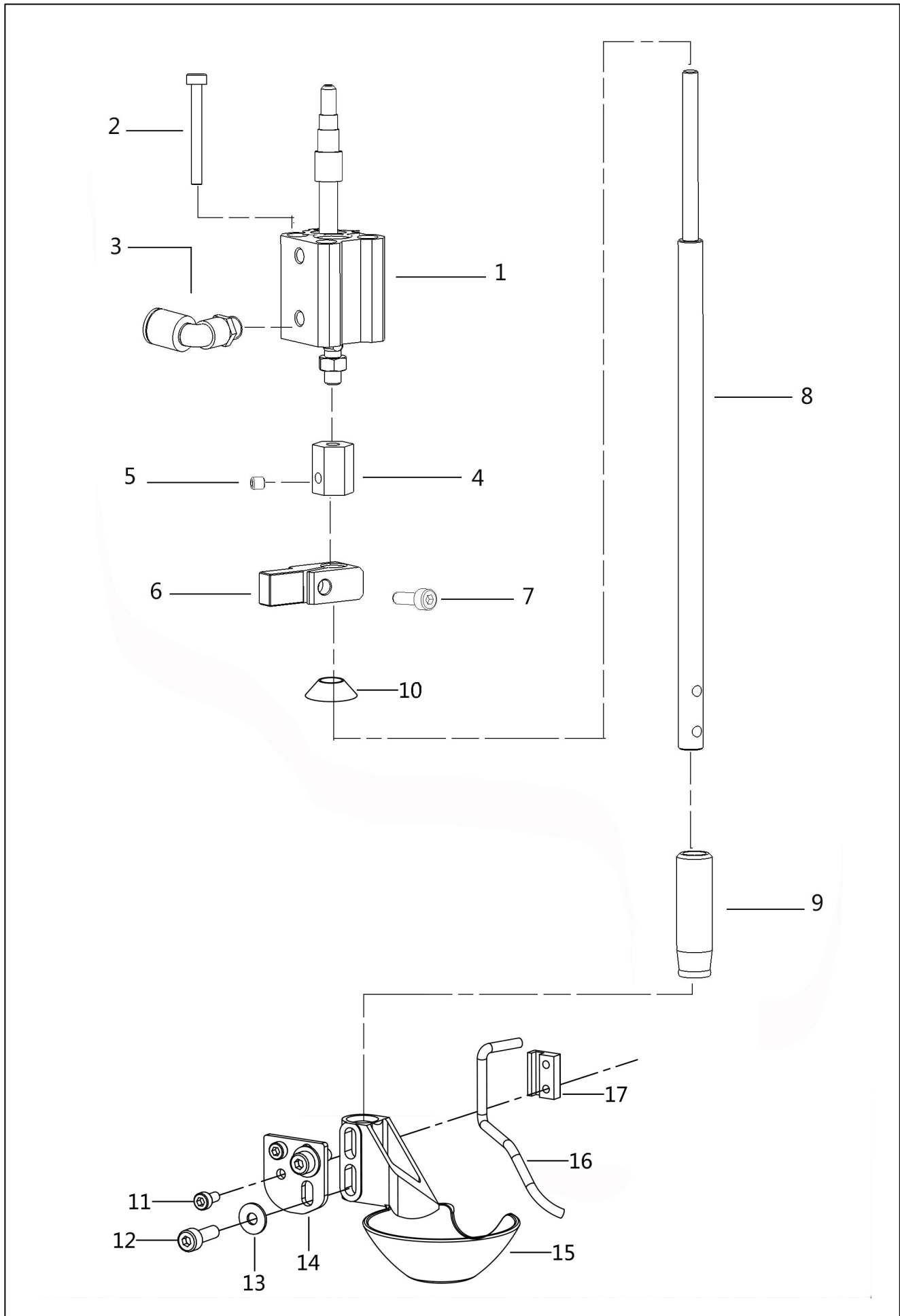

## 18、大压脚装置/External work clamp mechanism

序号 Ref.No.	件号 Part.No	对象描述	Description	数量 Amt.	备注 Remarks
1	41845016	行程可调节气缸12-17D	THE STROKE CAN ADJUST THE CYLINDER 12-17D	1	
2	418S13001	螺钉M3×55	SCREW M3×55	2	
3	41845231	接头ASL4-M5	CONTACK ASL4-M5	2	
4	41803024	大压脚气缸联轴器	BAG PRESSER FOOT CYLINDER COUPLING	1	
5	S10007	凹端紧定螺钉 M4×4 4H 发黑	CONCAVE SIDE SET SCREW M4X4	4	
6	41809213	大压脚压杆导架	BAG PRESSER FOOT PUSH ROD GUIDE	1	
7	S05133	螺钉 M4×12(镀镍)	SCREW M4×12	1	
8	41802220	大压脚压杆	BAG PRESSER FOOT PUSH ROD	1	
9	11403007	针杆下套	UNDER THE NEELE BAR SET	1	
10	41822101	橡皮垫	VALVE RUBBER	1	
11	S05192	螺钉M3×6	WASHER L3.5	2	
12	S05133	螺钉 M4×12(镀镍)	SCREW M4×12	2	
13	41728025	平垫圈L3.5	FLAT GASKET L3.5	2	
14	41812143	铜管安装板	COPPER PIPE MOUNTING PLATE	1	
15	41816031	大压脚D(小型金属)	BAG PRESSER FOOT D	1	
16	41821014	铜管D	COPPER PIPE D	1	
17	41801064	铜管压板	COPPER PIPE PLTEN	1	

# 19、断线感应装置/Thread breakage detector mechanism

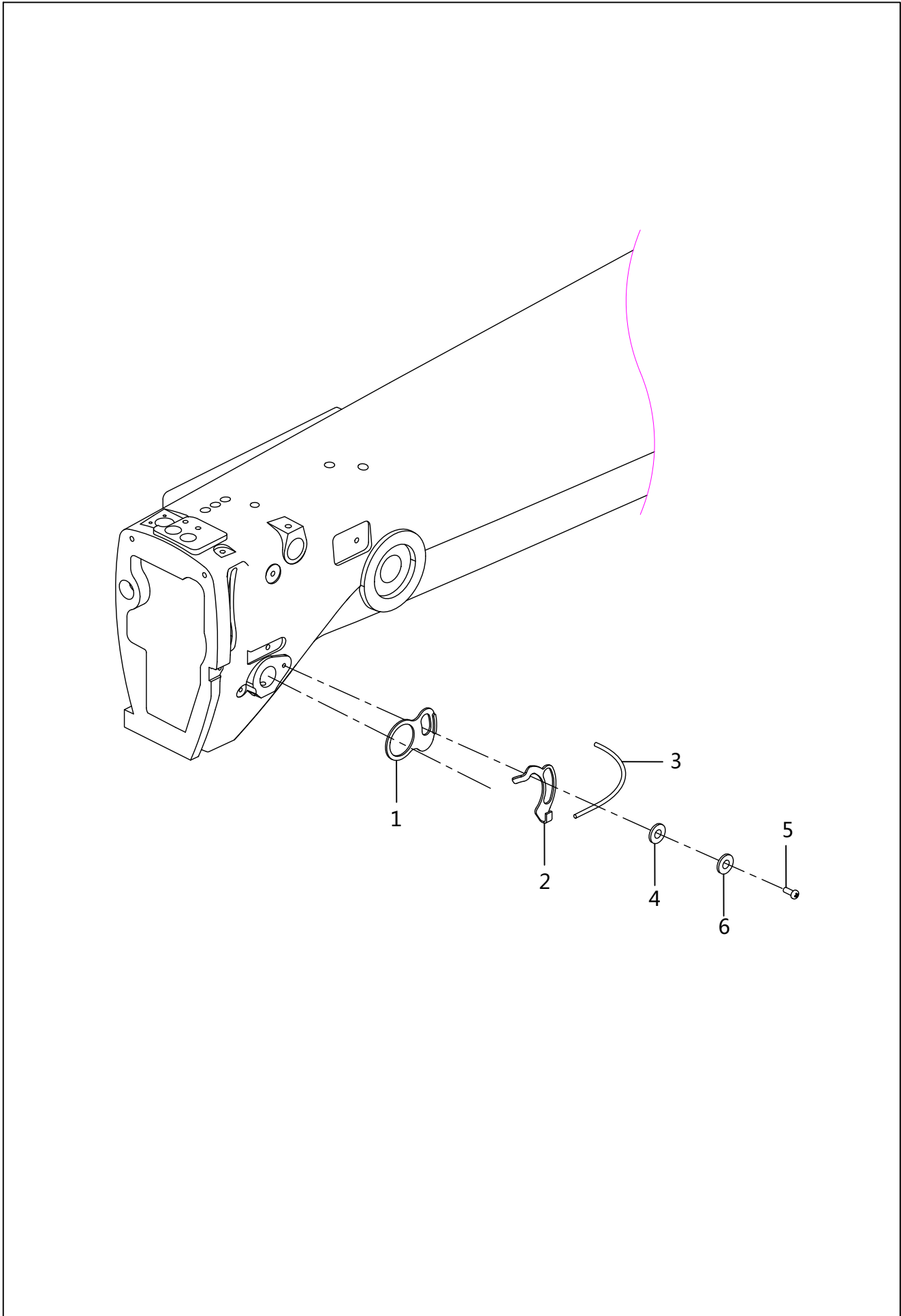

## 19、断线感应装置/Thread breakage detector mechanism

序号 Ref.No.	件号 Part.No	对象描述	Description	数量 Amt.	备注 Remarks
1	41711054	传感器内绝缘片	SENSOR INSULATION	1	
2	42212837	感应铜片	INDUCTION OF COPPER	1	
3	62800016	导线单芯 ( 0.2mm )	SINGLE CORE WIRES	2.5m	
4	41711053	传感器外绝缘片	SENSOR INSULATION	1	
5	S04078	螺钉M4×8 ( 镀镍 )	SCREW M4×8	1	
6	W01001	垫片M4	WASHER M4	1	

## 20、控制箱装置(双丝杆)/Control box mechanism(Two Lead Screws)

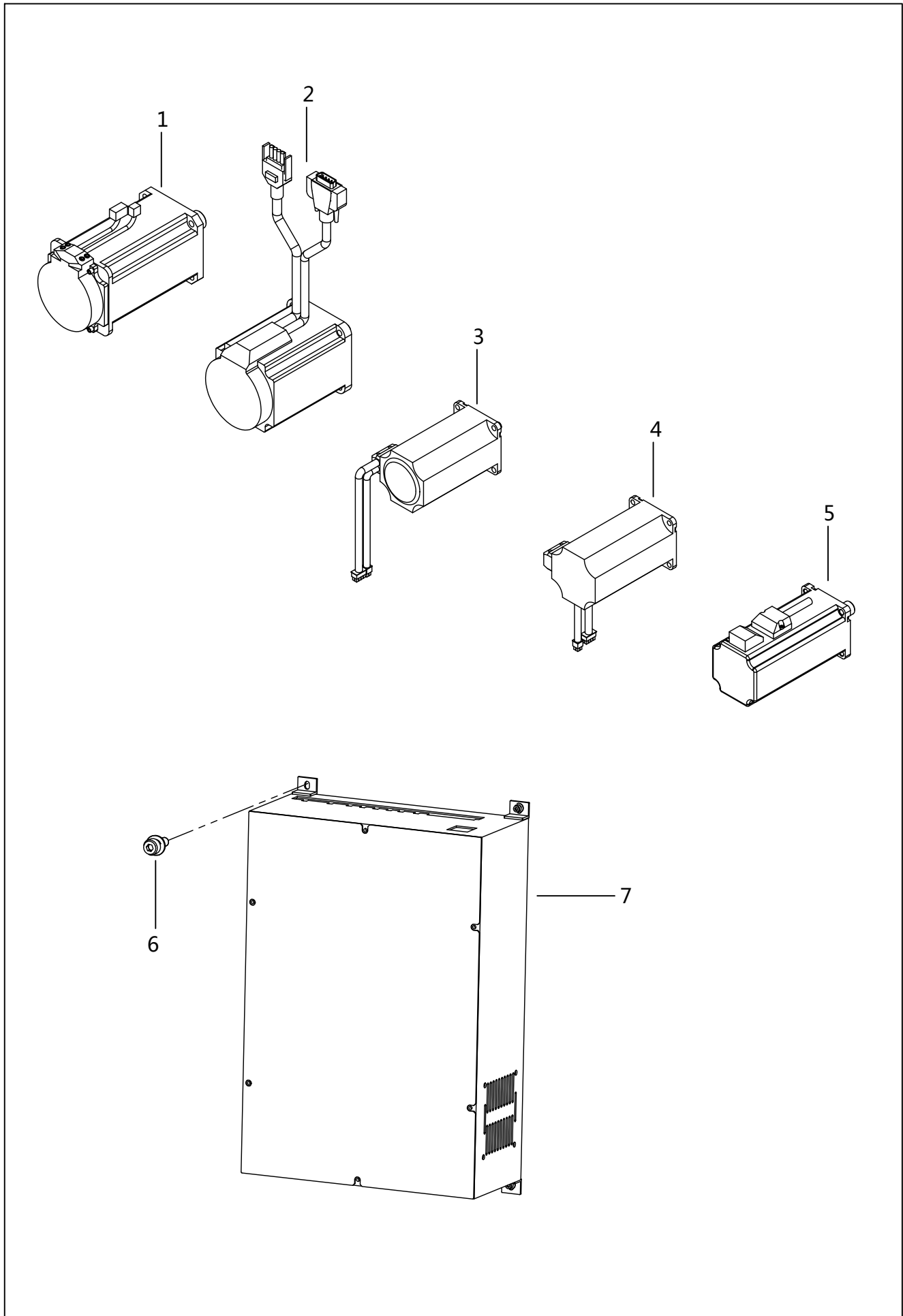

## 20、控制箱装置(双丝杆)/Control box mechanism(Two Lead

序号 Ref.No.	件号 Part.No	对象描述	Description	数量 Amt.	备注 Remarks
1	41833013	Y伺服电机	Y SERVO MOTOR	1	
2	41833212	主轴电机	SINDLE MOTOR	1	
3	41833213	中压脚步进电机(含光编)	MEDIUM VOLTAGE STEPPING MOTOR	1	
4	42230534	切线电机	SHEAR WIRE MOTOR	1	
5	41833016	X丝杆伺服电机	X LEAD SCREW SERVO MOTOR	1	
6	417S30302	内六角圆柱头螺钉M4×12	SCREW M4×12	4	
7	41830032	星火电控V2BP款	ELECTRONIC CONTROL (SPARK)	1	

## 21、开关装置/Switch mechanism

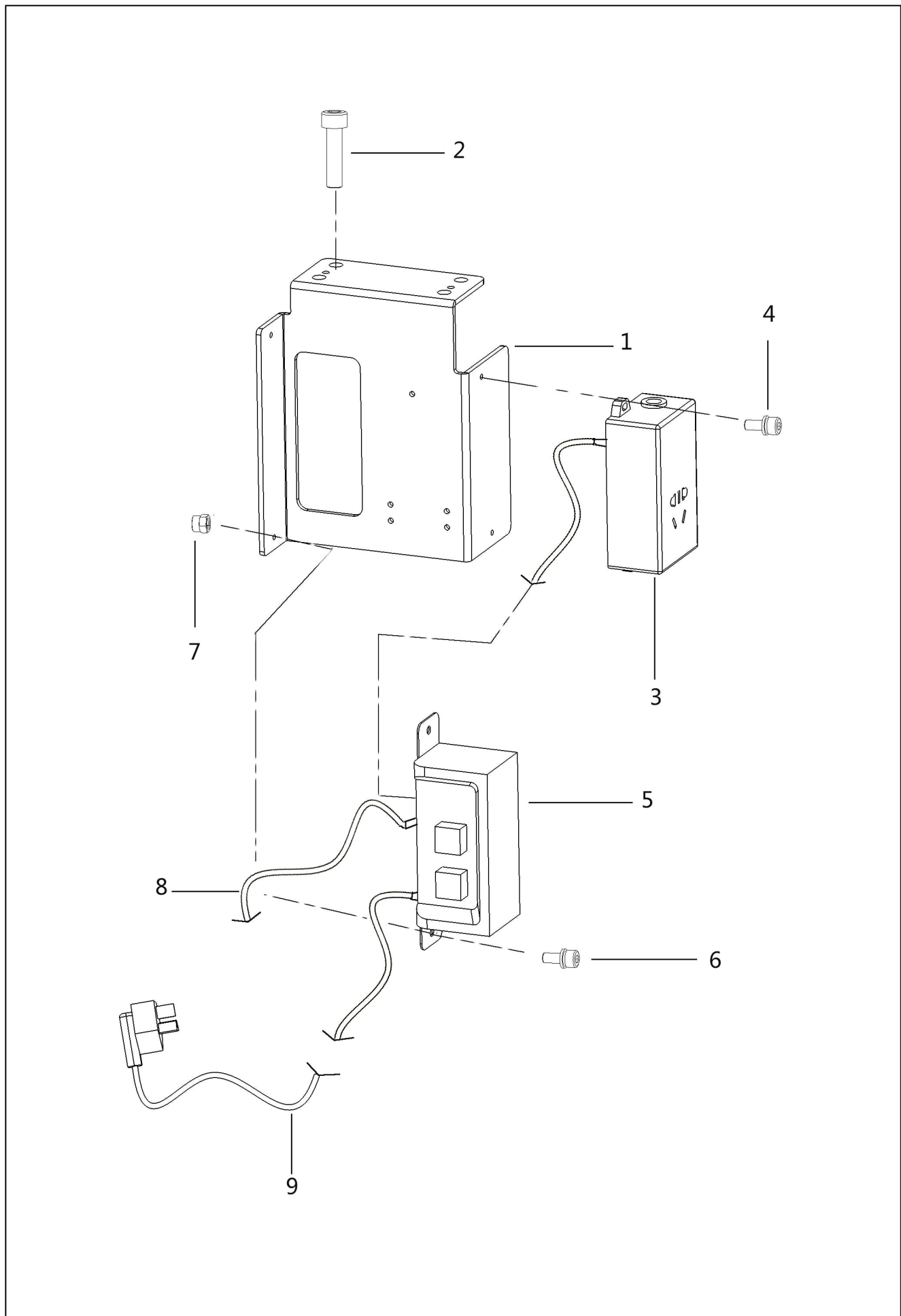

## 21、开关装置/Switch mechanism

序号 Ref.No.	件号 Part.No	对象描述	Description	数量 Amt.	备注 Remarks
1	41812060	电源开关支架	POWER SWITCH STAND	1	
2	S05124	螺栓 M5×16(滚花,镀镍)	SCREW M5×16	2	
3	41830021	插线板A01	PATCH BOARD A01	1	
4	417S30025	螺栓 (带垫圈) M4×10DB	SCREW (WITH WASHER)M4×10DB	2	
5	41830213	押扣开关	AND BUTTON SWITCH	1	
6	417S30025	螺栓 (带垫圈) M4×10DB	SCREW (WITH WASHER)M4×10DB	2	
7	407N01002	自锁螺母M4	SELF-LOCKING NUT	2	
8	99200037	电源线3m	POWER LINE 3M	1	
9	42230512	主电源开关线(5M)	MAIN POWER SWITCH LINE (5M)	1	

## 22、空压装置/Air pressure mechanism

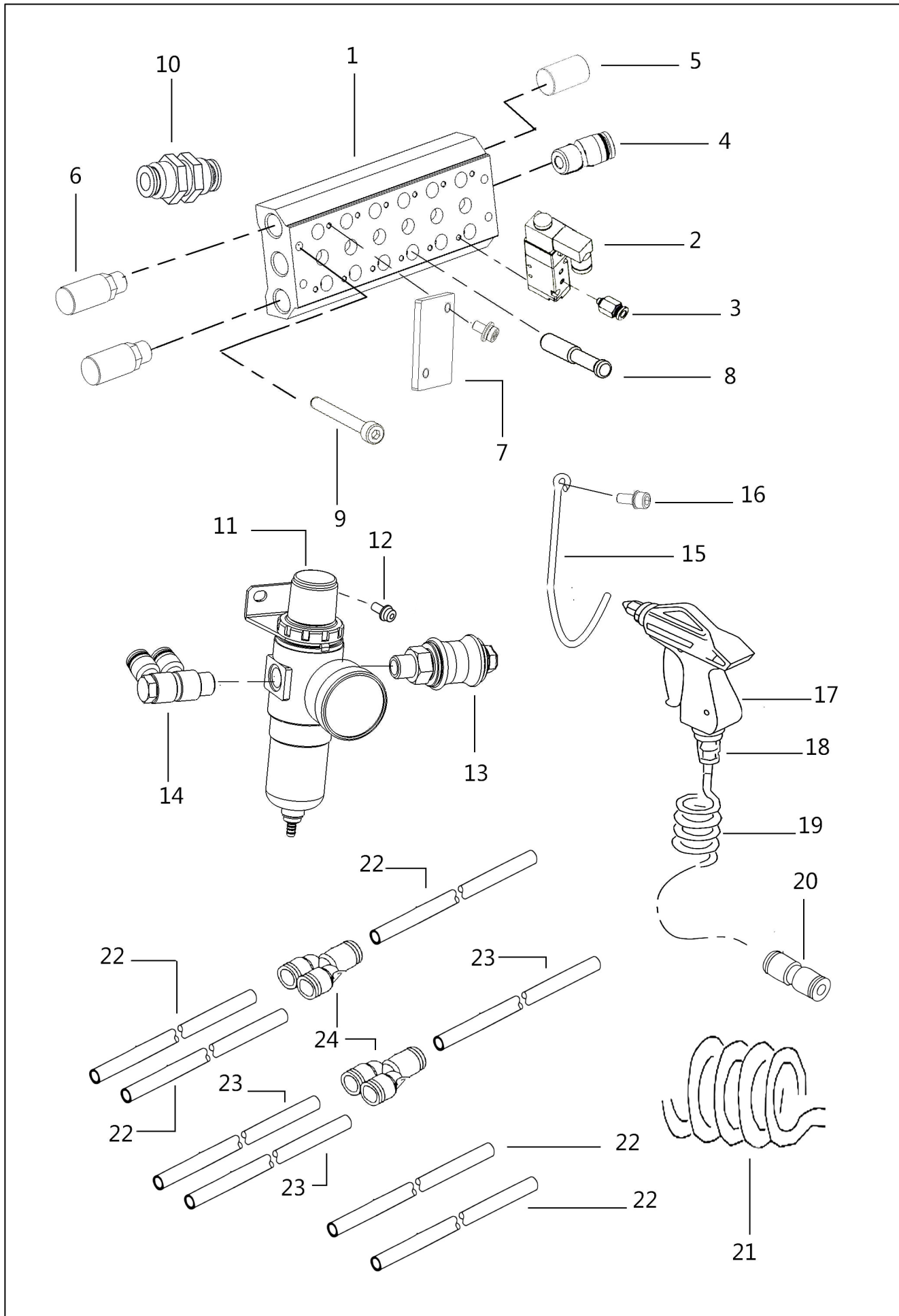

## 22、空压装置/Air pressure mechanism

序号 Ref.No.	件号 Part.No	对象描述	Description	数量 Amt.	备注 Remarks
1	41845021	双通汇流板100M6F	DOUBLE-PASS CONFLUENCE PLATE 100M6F	1	
2	41845212	电磁阀4V1106B	SOLENOID VALVE 4V1106B	4	
3	41845222	螺纹直通APC4-01	THREADED THROUGH APC4-01	8	
4	40736021	接头PL802	JOINT PL802	1	
5	41845219	内六角堵头ABP02	BEPT MALE HOLLOW PLUG ABP02	3	
6	41845214	消音器PAL02	SILENCER PAL02	2	
7	41845213	盖板	PLATE	2	
8	42122001	快换插头	QUICK CHANGE PLUG	2	
9	421S11013	螺栓 M4×35 (带垫圈)	SCREW (WITH WASHER) M4×35	4	
10	41845022	气管接头穿板直通PM8	CONNECT THE PIPE THROUGH THE PIPE	1	
11	41730650	气源处理元件	GAS SOURCE PROCESSING ELEMENTS	1	
12	417S30025	螺钉M4×10	SCREW M4×10	2	
13	42130096	手动开关VHK3	SWITCH VHK3	1	
14	42236512	气管接头APC8-02	PIPE CONNECT	1	
15	42212620	挂钩	POTHOOK	1	
16	417S30037	螺栓 M6×14(滚花,镀镍)	SCREW M6×14	1	
17	40730001	气枪	AIR GUN	1	
18	40736018	螺纹直通APC4-02	THREADED THROUGH APC4-02	1	
19	42211540	气管TCU0604B-1	WINDPIPE CU0604B-1	1	
20	40736022	气管接头APG6	GAS-TYPE FITTING APG6	1	
21	42221503	气管φ8	WINDPIPE φ8	10	
22	41845223	气管Φ4x2.5透明蓝	WINDPIPE Φ4x2.5 TRANSPARENT BLUE	16	
23	41845224	气管Φ4x2.5黑色	WINDPIPE Φ4x2.5 BLACK	18	
24	40736036	气管接头APY4(Y型三通)	GAS-TYPE FITTING APY4(Y THREE LINKS)	4	

## 23、电气部分装置/Power supply equipment mechanism

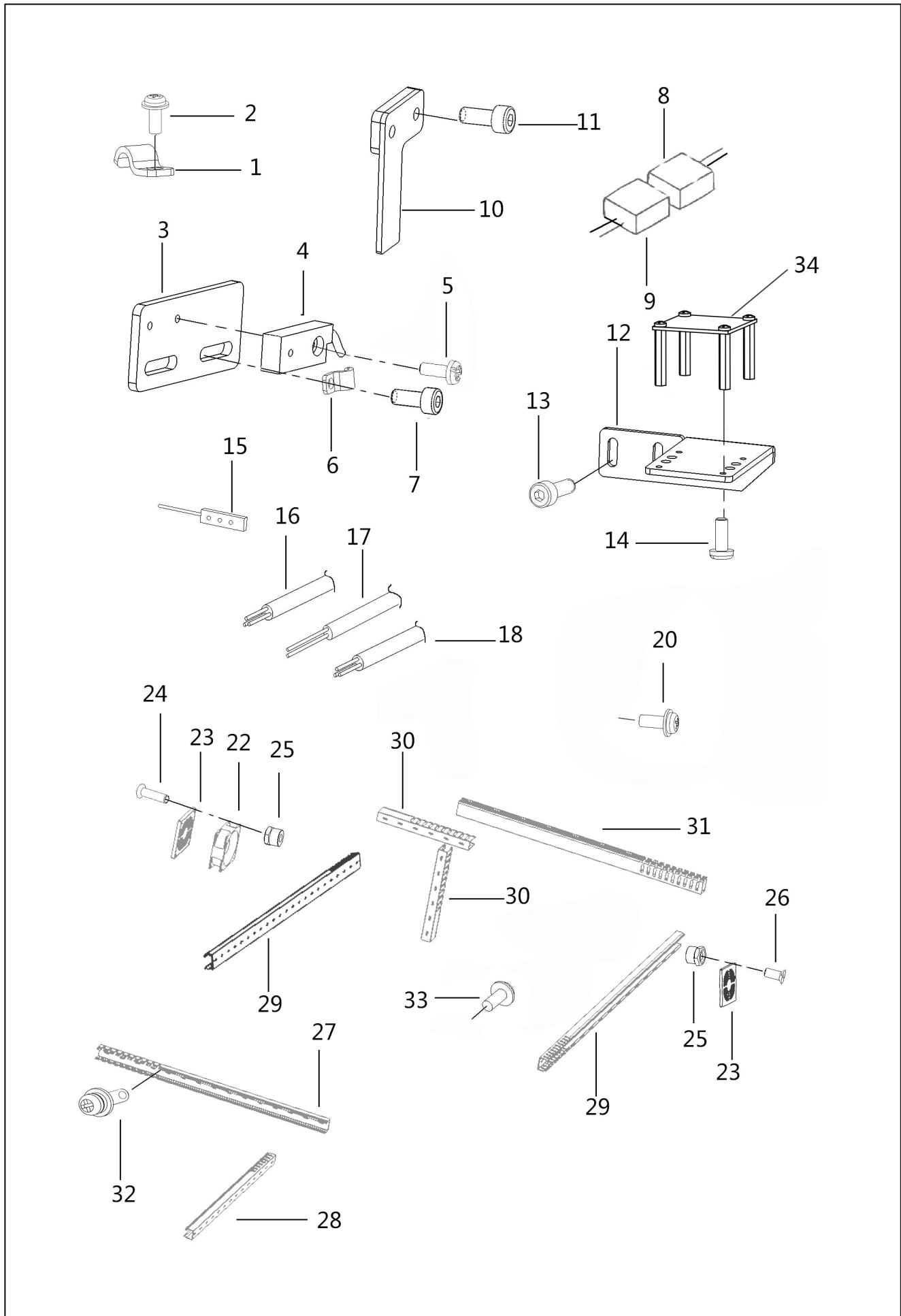

## 23、电气部分装置/Power supply equipment mechanism

序号 Ref.No.	件号 Part.No	对象描述	Description	数量 Amt.	备注 Remarks
1	41711026	电线夹23	WIRE CLIP 23	2	
2	417S30025	螺栓 (带垫圈) M4×10DB	SCREW (WITH WASHER) M4×10DB	2	
3	41812023	Y传感器安装座	Y SENSOR MOUNT	1	
4	41730851	传感器	SENSOR	1	
5	S04076	螺钉M3×8 (镀镍)	SCREW M3×8	1	
6	12912326	铜线夹	COPPER WIRE CLIP	1	
7	417S30302	螺栓 (带垫圈) M4×12	SCREW (WITH WASHER) M4×12	2	
8	42230004	X传感器接插件A	X SENSOR CONNECTOR A	1	
9	42230005	X传感器接插件B	X SENSOR CONNECTOR B	1	
10	4181202900	Y感应片组件	Y INDUCTOR	1	
11	S05133	螺栓M4×12	SCREW M4×12	2	
12	41812082	射频识别器安装板	RFID MOUNTING PLATE	1	
13	417S30302	螺栓 (带垫圈) M4×12	SCREW (WITH WASHER) M4×12DB	2	
14	S05094	螺钉 M3×8 (镀铬)	SCREW M3×8	4	
15	41730070	LED灯(TD-5)	LED LIGHT (TD-5)	2	
16	42230816	导线3C	WIRE 3C	3	
17	41730022	电磁阀接线	WIRE2C	9	
18	42230816	导线3C	WIRE 3C	2	
20	421S11012	M3×8螺钉	SCREW M3×8	4	
22	41830012	风扇	AIR FAN	1	
23	41811013	风扇防尘网罩组件	FAN DUST SCREEN COVER ASSEMBLY	2	
24	407S04001	4X16(沉头十字)	SCREW M4×16	4	
25	407N01002	自锁螺母M4	SELF-LOCKING NUT	8	
26	S02039	4X9 (沉头一字)	SCREW M4×9	4	
27	41811021	线槽3030L690	TRUNKING 3030L690	1	
28	41811022	线槽4030L650	TRUNKING 4030L650	1	
29	41811023	线槽4030L1150	TRUNKING 4030L1150	2	
30	41811024	线槽3050L300	TRUNKING 3050L300	2	
31	41811025	线槽3050L650	TRUNKING 3050L650	1	
32	417S30025	螺钉M4×10	SCREW M4×10	21	
33	417S30025	螺栓 (带垫圈) M4×10DB	SCREW (WITH WASHER) M4×10DB	2	
34	41830039	射频识别器	RFID MOUNTING	1	

## 24、操作界面装置/Operation interface mechanism

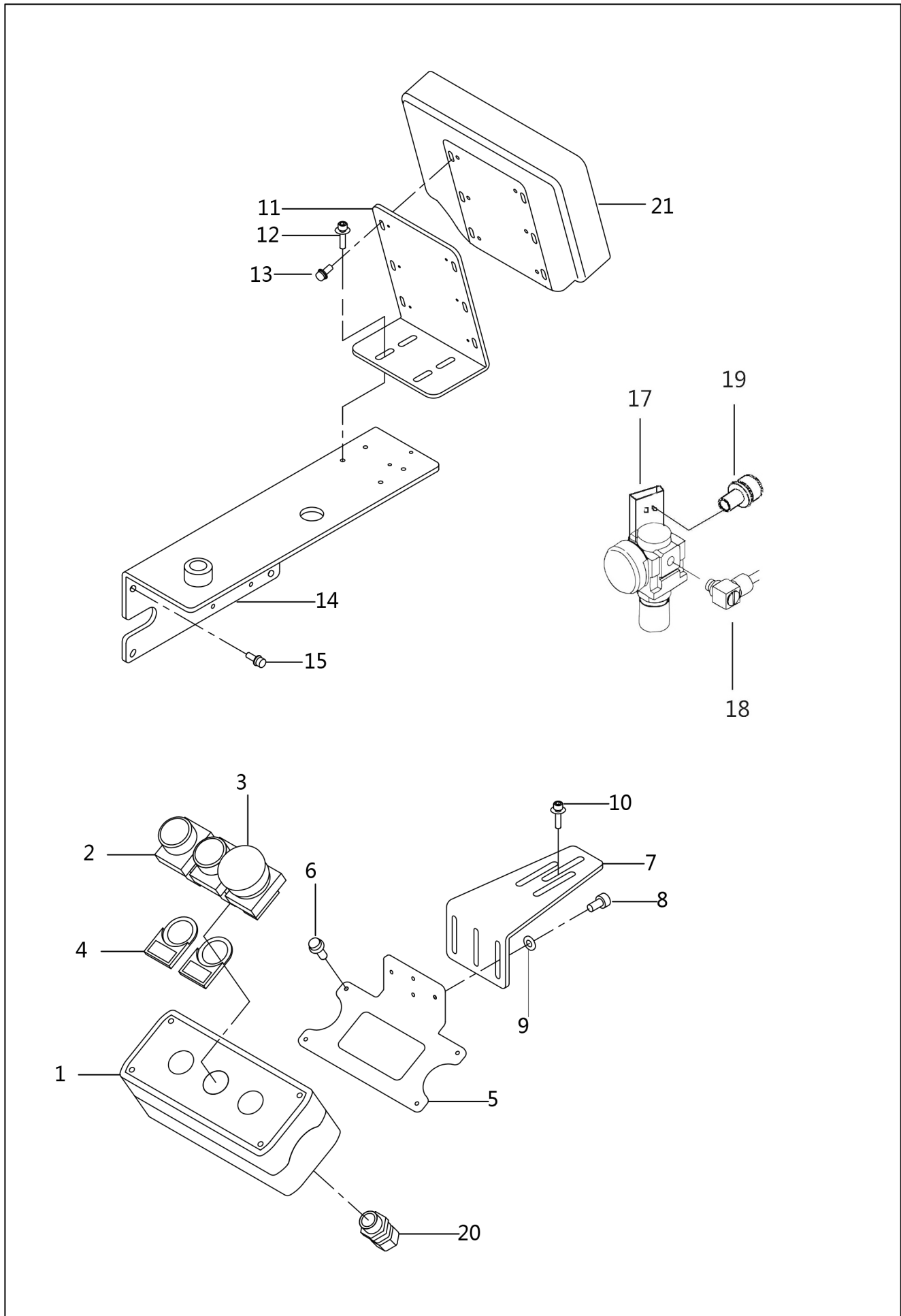

## 24、操作界面装置/Operation interface mechanism

序号 Ref.No.	件号 Part.No	对象描述	Description	数量 Amt.	备注 Remarks
1	41811214	按钮开关盒	PUSH BUTTON SWITCH BOX	1	
2	41830214	按钮开关	BOTTON SWITCH	2	
3	41830215	急停开关	EMERGENCY STOP BOTTON	1	
4	41811216	开关标牌框	SWITCH IDENTIFICATION BOX	2	
5	41812061	按钮盒安装板A	SWITCH BOX PLATE A	1	
6	417S30302	螺钉M4X12 (带垫圈)	SCREW(WITH WASHER) M4X12	4	
7	41812062	按钮盒安装板B	SWITCH BOX PLATE B	1	
8	S05116	螺栓 M4×8(滚花,镀镍)	SCREW M4×8	3	
9	W01001	垫片M4	WASHER M4	3	
10	417S30306	螺栓M5×15 (带垫片)	SCREW(WITH WASHER) M5X15	3	
11	304058	操作屏支架	OPERATING SCREEN SUPPORT	1	4181241300
12	417S30036	螺钉M5X12	SCREW M5X12	4	
13	417S30025	螺钉4X10 (带垫圈)	SCREW(WITH WASHER) M4X10	6	
14	304057	显示屏支架座组件	DISPLAY STAND ASSEMBLY	1	4181241000
15	417S30306	螺栓 M5×15(滚花,镀镍)	SCREW M5X15	4	
17	4073000900	压力调节器	PRESSURE REGULATOR	1	
18	42230519	微型接头M-5HLH-4	MICRO PIPE CONNECTION M-5HLH-4	2	
19	417S30033	M4X8(带垫圈)	SCREW(WITH WASHER) M4X8	2	
20	41811215	出线口	OUTLET	2	
21	41830040	显示屏	DISPLAY SCREENS	1	

## 25、机架部件/Table mechanism

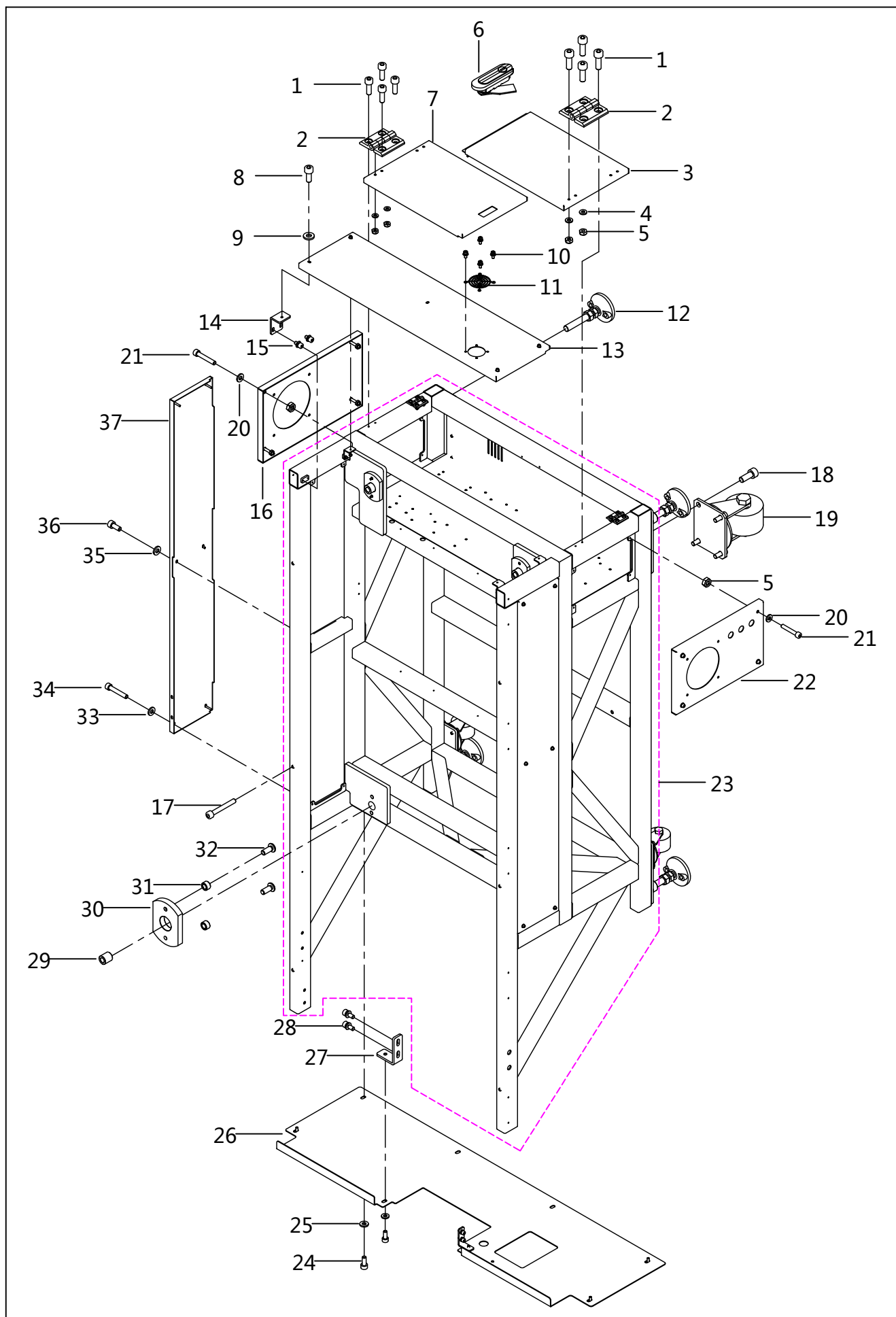

## 25、机架部件/Table mechanism

序号 Ref.No.	件号 Part.No	对象描述	Description	数量 Amt.	备注 Remarks
1	417S17852	螺钉M5×15	SCREW M5X15	16	
2	41831016	电控柜合页	ELECTRIC CONTROL CABINET HINGE	4	
3	304223	电控柜左门组件	ELECTRIC CONTROL CABINET LEFT DOOR	1	4181207400
4	41728028	垫圈M5	WASHER M5	8	
5	407N01001	自锁螺母M5	SELF-LOCKING NUT M5	16	
6	41831014	电控柜锁	ELECTRIC CONTROL CABINET LOCT	1	
	41812096	插销固定板	LATCH PLATE	2	焊接在机架
7	304224	电控柜右门组件	ELECTRIC CONTROL CABINET RIGHT DOOR COMPONENTS	1	41812075
8	S05123	螺栓M5X12	SCREW M5X12	4	
9	41728028	垫圈M5	WASHER M5	4	
10	417S30025	螺栓(带垫圈)M4×10DB	SCREW(WITH WASHER) M4X10	4	
11	41831013	风扇网罩	FAN NET	1	
12	41831212	脚垫	FOOT PAD	4	
13	304219	机架后盖组件	STAND BACK COVER COMPONENTS	1	4181206800
14	41812131	机架后盖固定板B	FRAME REAR COVER PLATE B	4	
15	417S30033	螺钉M4×8	SCREW M4X8	8	
16	304222	机架右后侧盖	THE REAR SIDE COVER OF THE RACK	1	41812072
17	S05088	螺钉M6X45	SCREW M6X45	6	
18	701S13002	螺钉M8×12	SCREW M8X12	16	
19	42232502	脚轮	TRUNDLE	4	
20	41728028	垫圈M5	WASHER M5	8	
21	S05083	螺栓M5X30	SCREW M5X30	8	
22	304221	机架左后侧盖	THE REAR SIDE COVER OF THE RACK	1	41812071
23	304215	机架组件	RACK COMPONENTS	1	4183201400
24	S05123	螺栓M5X12	SCREW M5X12	8	
25	41728028	垫圈M5	WASHER M5	8	
26	304217	机架前盖组件	FRAME COVER COMPONENTS	1	4181206600
27	41812013	机架前盖支架板	FRAME COVER PLATE	2	
28	417S30036	螺栓(带垫圈)M5X12	SCREW M5X12	4	
29	41803018	定位套	LOCATING SLEEVE	4	
30	41822014	减振橡胶垫	DAMPING RUBBER PAD	4	
31	41803019	管套	PIPE SHROUD	8	
32	417S13301	螺栓M5X12	SCREW M5X12	8	
33	41728028	垫圈M5	WASHER M5	8	
34	S05083	螺栓M5X30	SCREW M5X30	8	
35	41728028	垫圈M5	WASHER M5	4	
36	S05123	螺栓M5X12	SCREW M5X12	4	
37	304216	机架侧盖	FRAME SIDE COVER	2	41812064

## 26、辅助台面装置/Auxiliary table mechanism

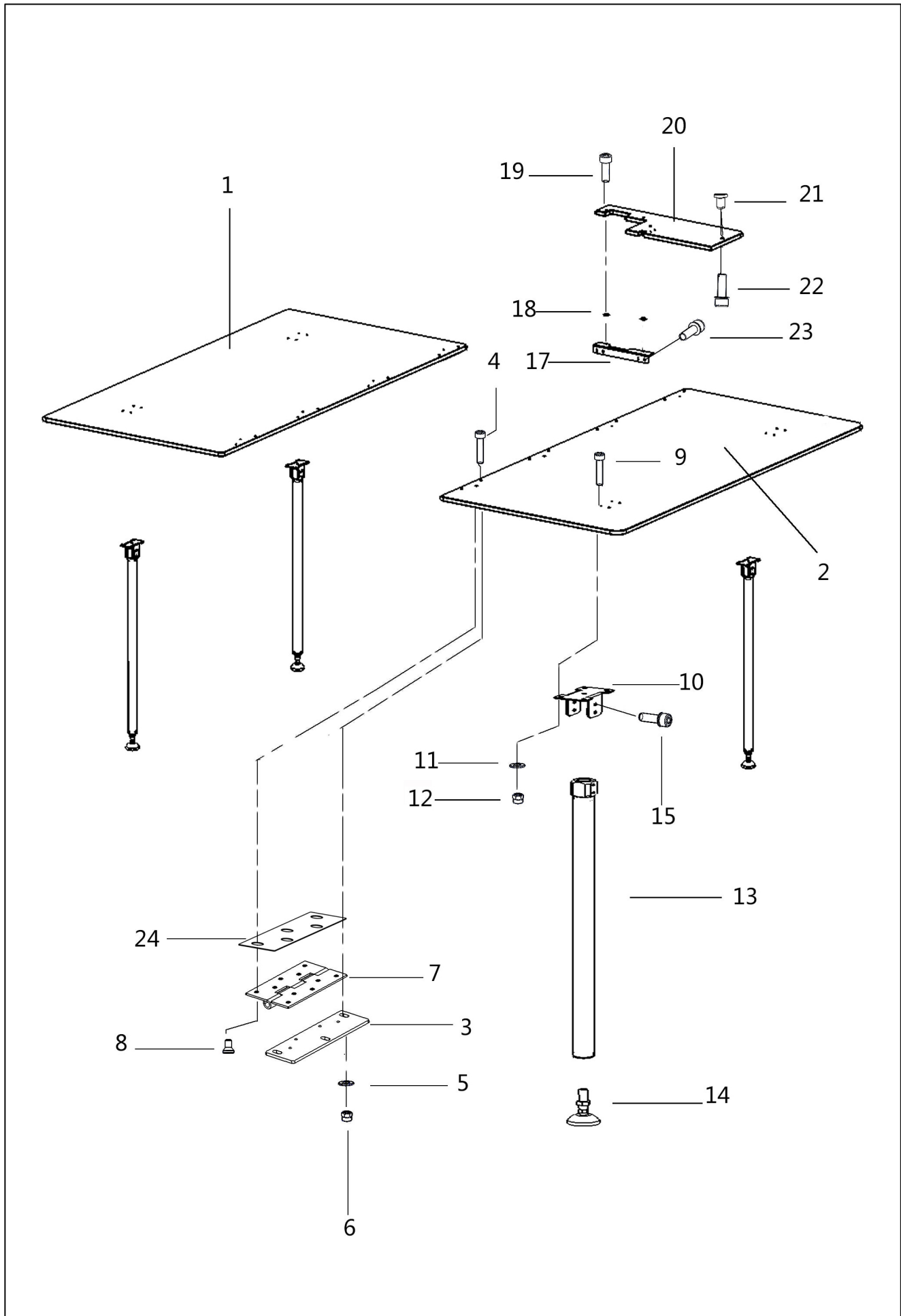

## 26、辅助台面装置/Auxiliary table mechanism

序号 Ref.No.	件号 Part.No	对象描述	Description	数量 Amt.	备注 Remarks
1	41832015	左辅助台面	LEFT AUXILIARY TABLE	1	
2	41832021	右辅助台面	RIGHT AUXILIARY TABLE	1	
3	41812079	合页固定板	HINGE PLATE	8	
4	S05035	螺栓M5X25	SCREW M5X25	24	
5	41728028	垫圈5	WASHER M5	24	
6	407N01001	自锁螺母M5	SELF-LOCKING NUT M5	24	
7	41831213	合页5寸	HINGE 5	8	
8	418S17211	沉头5X6	SCREW 5X6	64	
9	S05035	螺栓M5X25	SCREW M5X25	16	
10	41812080	辅助支撑铰链支架	AUXILIARY SUPPORT HINGE BRACKET	4	
11	41728028	垫圈5	WASHER M5	16	
12	407N01001	自锁螺母M5	SELF-LOCKING NUT M5	16	
13	303905	支撑柱组件	SUPPORT COLUMN ASSEMBLY	4	4183201600
14	41832020	脚垫M12	FOOT PAD M12	4	
15	417S30304	螺栓M6X20	SCREW M6X20	8	
17	4181205100	后辅助台面支撑板组件	REAR PANEL SUPPORT PANEL ASSEMBLY	1	
18	41822012	减振垫圈	BUFFRE WASHER	2	
19	S05124	螺栓 M5×16(滚花,镀镍)	SCREW M5X16	3	
20	41832012	后辅加台面	BACK TABLE	1	
21	418S16014	滚花螺纹套M6	KNURLED THREAD SLEEVE	1	
22	417S30037	螺栓 M6×14(滚花,镀镍)	SCREW M6X14	1	
23	417S30037	螺栓 M6×14(滚花,镀镍)	SCREW M6X14	4	
24	41812009	5寸合页垫片	5-INCH HINGE GASKET	8	

## 27、附件/Accessories

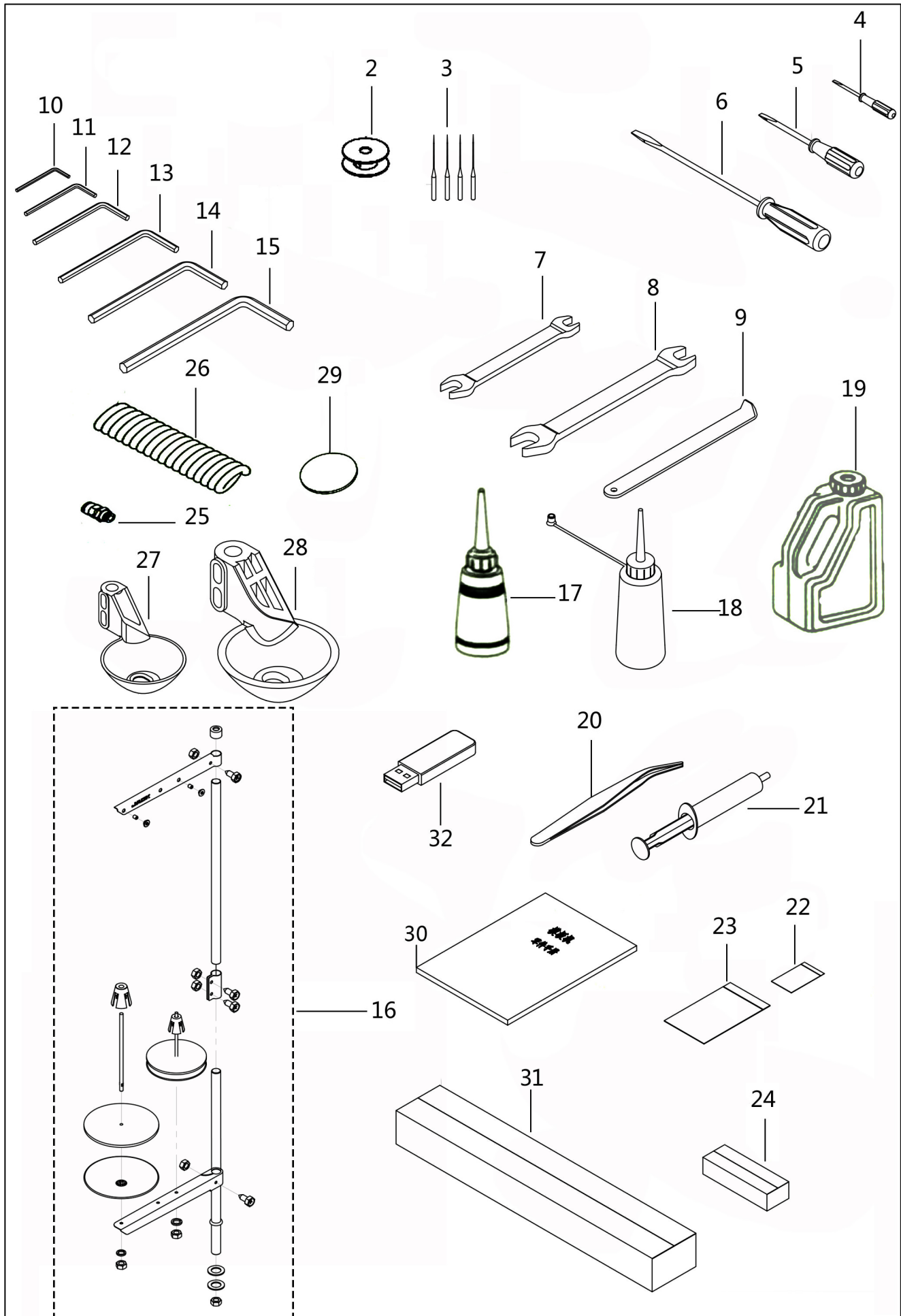

## 27、附件/Accessories

序号 Ref.No.	件号 Part.No	对象描述	Description	数量 Amt.	备注 Remarks
1	42211812	机头支撑	HEAD SUPPORT	1	
2	10818501	梭心605.609大梭心	COP LATCH	3	
3	42217504	机针DP×5 8#	NEEDLE DP×5 8#	4	
4	10131004	螺丝刀 (小)	SCREW DRIVER LARGR	1	
5	10131003	螺丝刀 (中)	SCREW DRIVER MIDDLE	1	
6	10131002	螺丝刀 (大)	SCREW DRIVER SMALL	1	
7	30131005	扳手 (6mm~7mm)	WRENCH (6mm~7mm)	1	
8	30131006	扳手 (8mm~10mm)	WRENCH (8mm~10mm)	1	
9	41712355	针板专用螺丝刀	NEEDLE PLATE SPECIAL SCREWDRIVER	1	
10	30131007	内六角扳手 (1.5mm)	INTERNAL HEXAGONAL WRENCH (1.5mm)	1	
11	20131046	内六角扳手 (2mm)	INTERNAL HEXAGONAL WRENCH (2mm)	1	
12	30131010	内六角扳手(2.5mm)	INTERNAL HEXAGONAL WRENCH (2.5mm)	1	
13	30131012	内六角扳手(3mm)	INTERNAL HEXAGONAL WRENCH (3mm)	1	
14	20131047	内六角扳手(4mm)	INTERNAL HEXAGONAL WRENCH (4mm)	1	
15	20131056	内六角扳手(5mm)	INTERNAL HEXAGONAL WRENCH (5mm)	1	
16	1013100700	线架组件	WIRE FRAME COMPONENT	1	
17	11631008	油壶	OILER ASM	1	
18	20131038	小油壶	SMALL OILER ASM	1	
19	915305	工业白油	INDUSTRIAL WHITE OIL	1	
19	1011101200	油箱组件	TANK COMPONENTS	1	
20	20131051	镊子	TWEEZERS	1	
21	11411029	注射器	INJECTOR	1	
22	20131076	15×9袋	15X9 BAG	6	
23	20131077	20×15袋	20X15 BAG	2	
24	41731015	花样机附件箱	ACCESSORY CASE	1	
25	40736001	螺纹套管接头	SCREWED JOINT	1	
26	40730010	螺旋气管	SPIRAL TUBE	6	
27	41816211	大压脚B	BIG PRESSER FOOT B	4	
28	41811015	大压脚C	BIG PRESSER FOOT C	3	
29	41830017	电子标签卡	ELECTRONIC TAG CARD	30	
30	141831040	零件图册	PART MAP BOOK	1	
31	141831017	横梁纸箱	X FEEDING ACCESSORY BOX	1	
32	42230854	U盘	USB	1	

# 28、点笔装置（选配） /Pint pen mechanism(SELECTABLE)

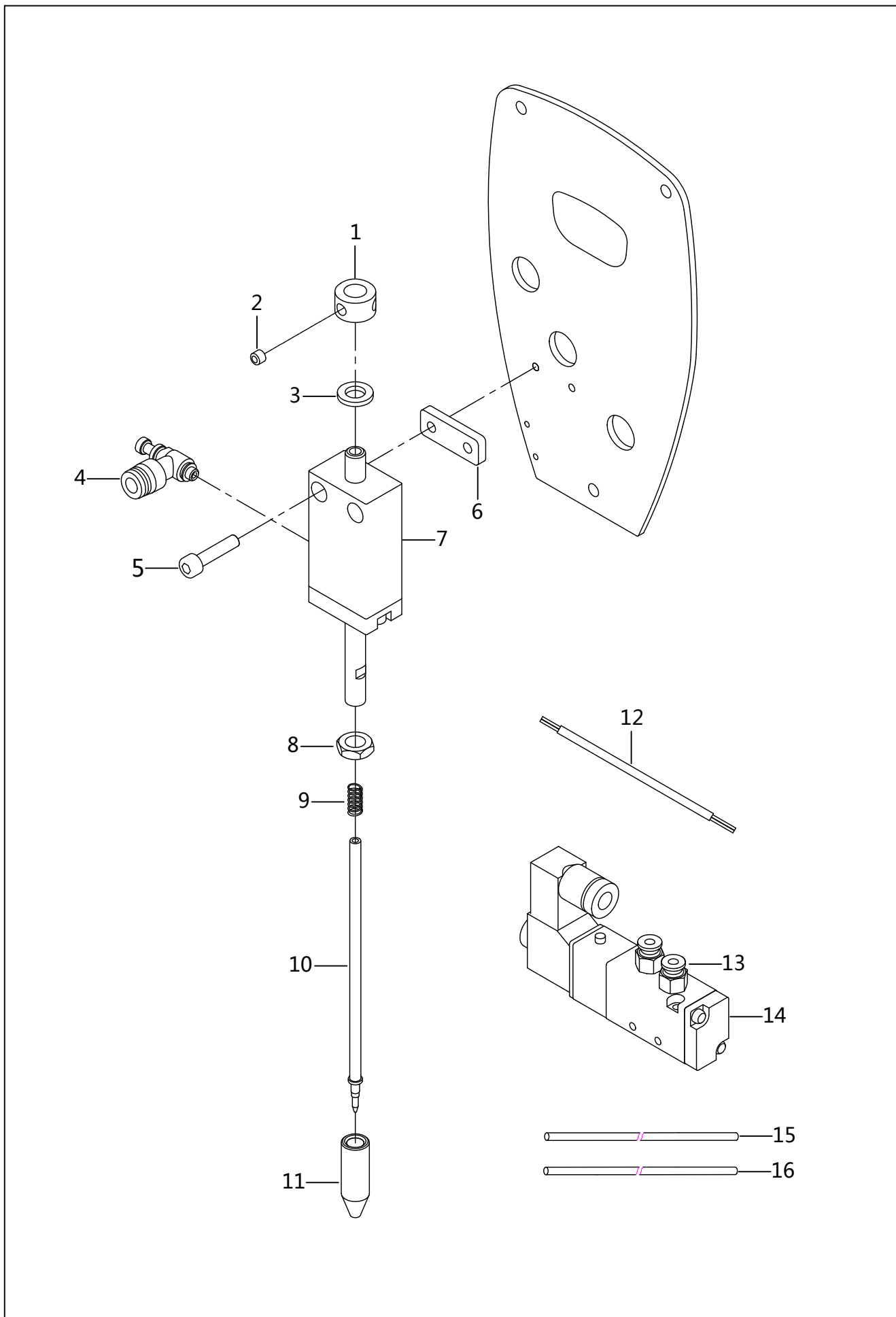

## 28、点笔装置（选配） /Pint pen mechanism(SELECTABLE)

序号 Ref.No.	件号 Part.No	对象描述	Description	数量 Amt.	备注 Remarks
1	41708002	紧圈B	HEAD SUPPORT	1	
2	S10019	螺钉M6×6	COP LATCH	2	
3	41722020	电磁铁缓冲垫圈	NEEDLE DP×5 8#	1	
4	41845231	接头ASL4-M5	SCREW DRIVER LARGR	2	
5	S05119	螺栓M4×20	SCREW DRIVER MIDDLE	2	
6	41809304	气缸垫块	SCREW DRIVER SMALL	1	
7	41830304	气缸CMDD16×25	WRENCH ( 6mm ~ 7mm )	1	
8	N02030	螺母M8×1	WRENCH ( 8mm ~ 10mm )	1	
9	41712355	点笔弹簧	NEEDLE PLATE SPECIAL SCREWDRIVER	1	
10	41811302	点笔笔芯	INTERNAL HEXAGONAL WRENCH ( 1.5mm )	1	
11	418516304	点笔杆锁帽	INTERNAL HEXAGONAL WRENCH ( 2mm )	1	
12	41730022	电磁阀接线	INTERNAL HEXAGONAL WRENCH (2.5mm)	1	0.45m
13	41845222	螺纹直通APC4-01	INTERNAL HEXAGONAL WRENCH (3mm)	2	
14	41845212	电磁阀4V110-06-B	INTERNAL HEXAGONAL WRENCH (4mm)	1	
15	41845224	气管φ4×2.5黑色	INTERNAL HEXAGONAL WRENCH (5mm)	1	3m
16	41845223	气管φ4×2.5透明蓝	WIRE FRAME COMPONENT	1	3m