

LH-4500C

FRAME & MISCELLANEOUS COVER COMPONENTS

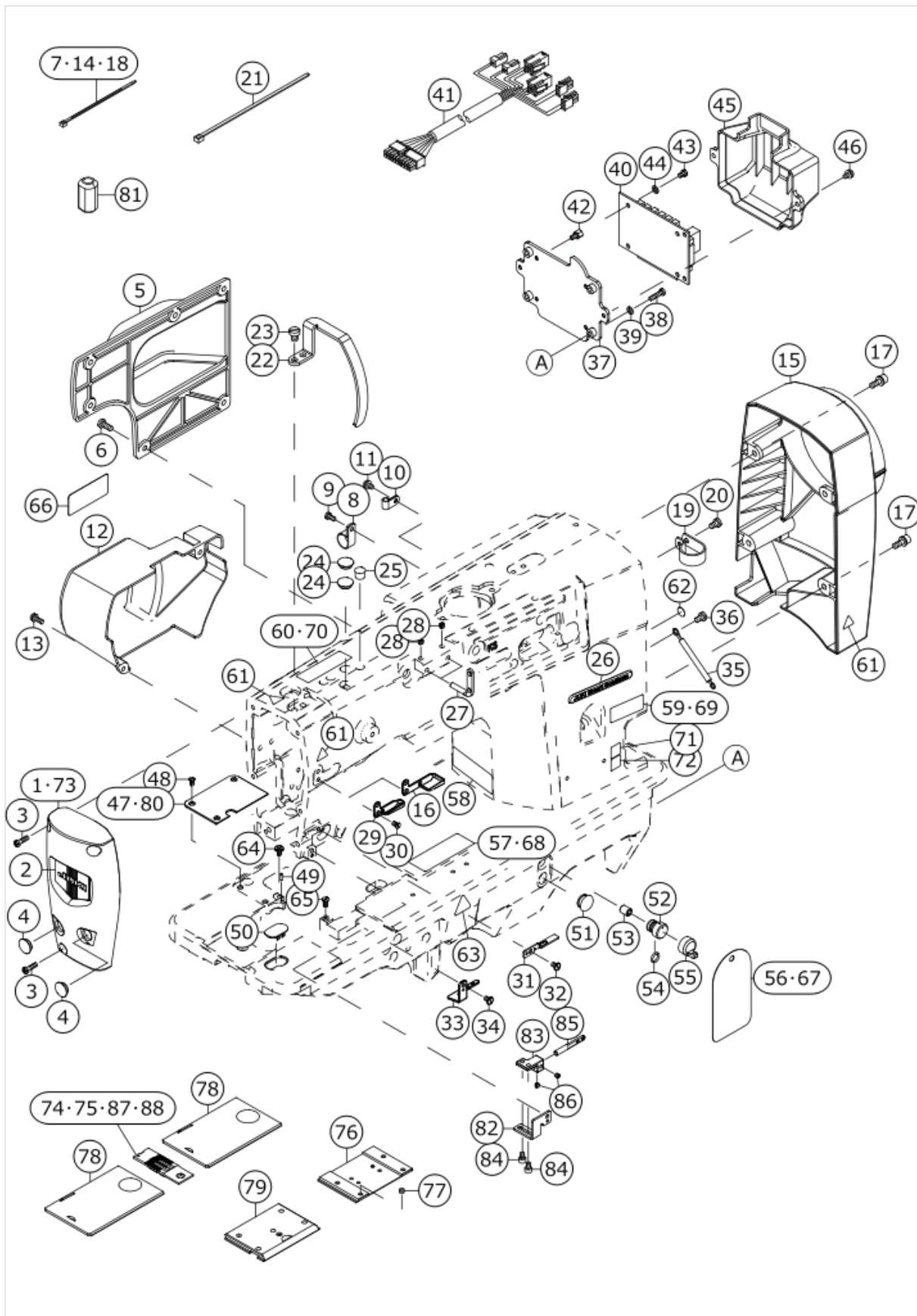

No.	品番	品名	備考	子部品	消耗品	個数
1	40220076	FACE_COVER_88	WITH ONE NEEDLE			1.00
2	40172374	FACE_COVER_PLATE				1.00
3	SM4041455SN	SCREW M4 L=14				3.00
4	TA1250406R0	RUBBER PLUG D=12.5 L=4				2.00
5	40172364	AK_COVER				1.00
6	SM4051255SP	SCREW				6.00
7	EA9500B0100	CABLE BAND				4.00
8	HX00150000H	CABLE CLAMP				1.00
9	SM4040855SP	SCREW				1.00
10	HX00150000A	CABLE CLAMP				1.00
11	SL4040891SC	SCREW M4 L=8				1.00
12	40220131	AT_COVER				1.00
13	SL4041281SC	SCREW M4 L=12				2.00
14	EA9500B0100	CABLE BAND				2.00
15	40220078	PULLY_COVER				1.00
16	40091179	THREAD_GUIDE_UPPER	TYPE S AND TYPE F			1.00
17	SL6051492TN	SCREW M5 L=14				4.00
18	EA9500B0100	CABLE BAND				1.00
19	HX00150000M	CABLE CLAMP				1.00
20	SM4050855SP	SCREW				1.00
21	EA9500B0200	CABLE BAND				3.00
22	40220081	THREAD_TAKE_UP_LEVER_COVER				1.00
23	SM6060800SP	SCREW M6 L=8				2.00
24	TA1250406R0	RUBBER PLUG D=12.5 L=4				2.00
25	TA0950806R0	RUBBER PLUG				1.00
26	40199299	EMBLEM_JUKI_SMART_SOLUTIONS_S				1.00
27	22920706	TWO EYELET				2.00
28	SM8050412TP	SCREW M5 L=4				2.00
29	40029078	THREAD_GUIDE_UPPER	TYPE G			1.00
30	SM1040750TP	SCREW M4 L=7				1.00
31	40232786	THREAD_GUIDE_UPPER				1.00
32	SM6040650TP	SCREW				1.00
33	40220214	THREAD_GUIDE_LOWER	FOR LH-4578C (TYPE F)			1.00
34	SM6040650TP	SCREW				1.00
35	40189389	GROUND WIRE ASM				1.00
36	SM4050855SP	SCREW				1.00
37	40220260	INT_PCB_COVER_BASE				1.00
38	SM4041655SP	SCREW M4 L=16				4.00
39	WP0430800SD	WASHER M4				4.00
40	40208490	INT PCB ASSY				1.00
41	40220227	SOL - CTL CABLE ASSY				1.00
42	HX00339000Q	SPACER				4.00
43	SM4040655SP	SCREW				4.00
44	WP0430800SD	WASHER M4				4.00
45	40220259	INT_PCB_COVER				1.00
46	SL4040881SC	SCREW M4 L=8				2.00
47	40220210	AUXILIARY_COVER_TRIM				1.00

48	SM1040750TP	SCREW M4 L=7				3.00
49	B1104051000	THROAT PLATE PIN				1.00
50	40224214	CAP				2.00
51	TA1250705R0	RUBBER PLUG				1.00
52	23629900	AIR-DISCHARGING				1.00
53	40223585	SPRING_PIN				1.00
54	RO080150200	O-RING				1.00
55	23601305	AIR-DISCHARGING CAP				1.00
56	23640006	SHEET	EXCEPT CHINA			1.00
57	CM301100102	LABEL_03	EXCEPT CHINA			1.00
58	40102261	SAFETY_LABEL_S				1.00
59	CM200200202	LABEL_02	EXCEPT CHINA			1.00
60	CM200100102	LABEL_01	EXCEPT CHINA			1.00
61	CM300200001	FINGER INJURY CAUTION LABEL (16)				3.00
62	22901805	GROUND MARK				1.00
63	CM300200002	FINGER INJURY CAUTION LABEL (25)				1.00
64	40220203	SCREW				1.00
65	SS2110920TP	SCREW 11/64-40 L=8.5				1.00
66	40094561	SEWING MACHINE LABEL (EU)	FOR JCE			1.00
67	40037488	SHEET	FOR CHINA			1.00
68	CM301100101	LABEL_03_C	FOR CHINA			1.00
69	CM200200201	LABEL_02_C	FOR CHINA			1.00
70	CM200100101	LABEL_01_C	FOR CHINA			1.00
71	CM600100101	WEEE MARK LABEL S	FOR JCE			1.00
72	40150131	EAC_MARK_LABEL_S	FOR JCE			1.00
73	40220074	FACE_COVER_78	WITHOUT ONE NEEDLE			1.00
74	40221496	THROAT_PLATE	FOR LH-4578C (TYPE F)			1.00
75	40220201	THROAT_PLATE_TRIM_G				1.00
76	23206709	BED SLIDE (FRONT)A	FOR LH-4578C (TYPE F)			1.00
77	SS8110410TP	SCREW 11/64-40 L=3.5	FOR LH-4578C (TYPE F)			1.00
78	40220206	ASSY_SLIDE_PLANTE-A				2.00
79	40042880	ASSY_SLIDE_PLATE_F	TYPE S AND TYPE G			1.00
80	40220211	AUXILIARY_COVER	FOR LH-4578C (TYPE F)			1.00
81	HN002840000	CORES	FOR JCE			1.00
82	40228888	THREAD_GUIDE_LOWER_PLATE	TYPE S AND TYPE G			1.00
83	40228887	THREAD_GUIDE_LOWER_BASE	TYPE S AND TYPE G			1.00
84	SM6040602TN	BOLT	TYPE S AND TYPE G			2.00
85	40228886	THREAD_GUIDE_LOWER	TYPE S AND TYPE G			1.00
86	SM8040812TP	SCREW M4 L=8	TYPE S AND TYPE G			2.00
87	40025492	THROAT_PLATE_TRIM-1/4	TYPE S (WITH TRIM)			1.00

88	22625503	THROAT PLATE 1/4	TYPE S (WITHOUT TRIM)			1.00
----	----------	------------------	-----------------------	--	--	------

MAIN SHAFT COMPONENTS

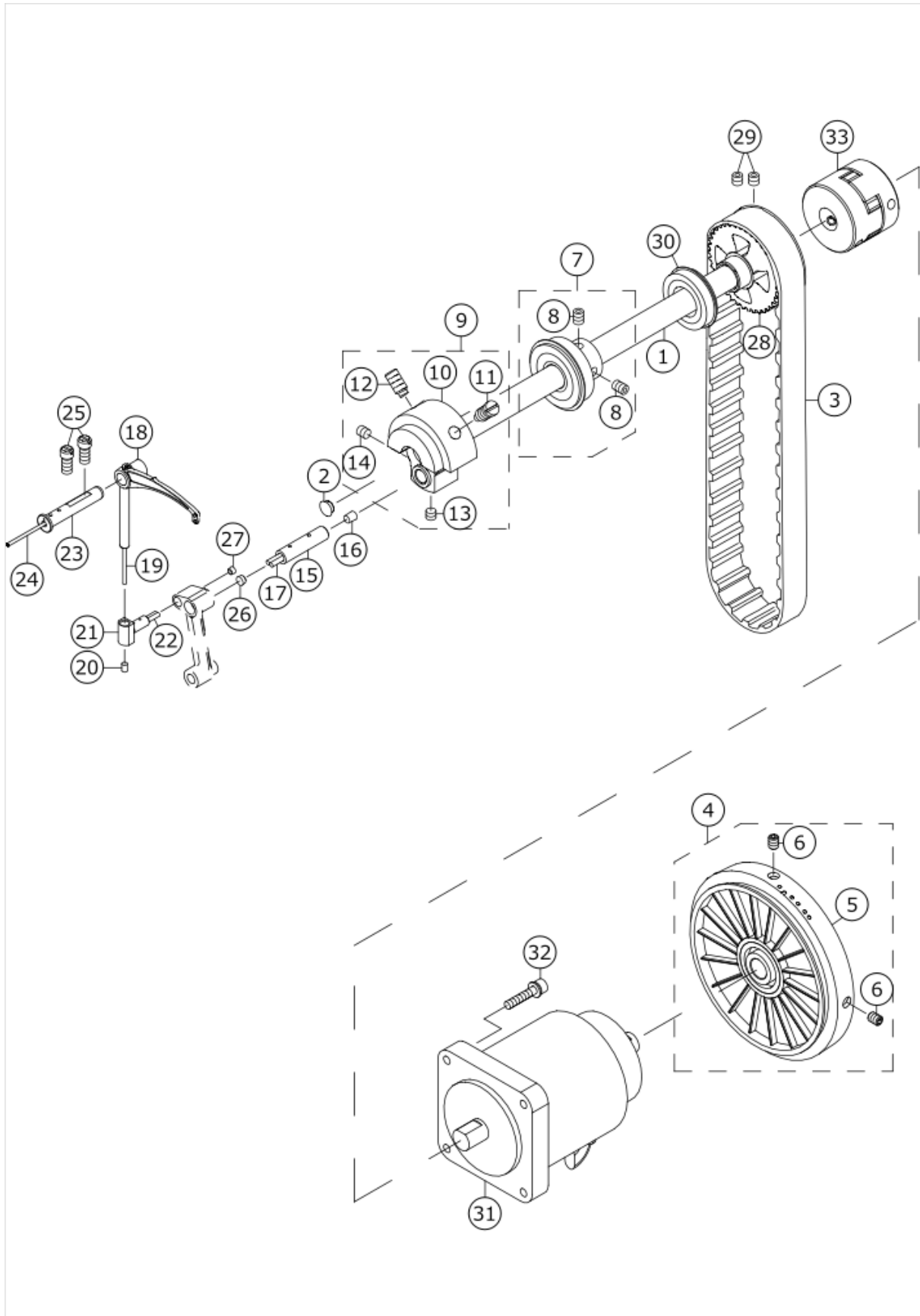

No.	品番	品吊	備考	子部品	消耗品	個数
1	40220086	MAIN_SHAFT				1.00
2	TA0750404R0	PLUG D=7.5 L=3.5				1.00
3	40112274	TIMING_BELT				1.00
4	40223555	HAND_WHEEL_ASM				1.00
5	40223556	HAND_WHEEL		*		1.00
6	SM80608A2TP	SCREW M6 L=8		*		2.00
7	40142685	FRONT_BEARING				1.00
8	40010417	BEARING_BUSH_SCREW		*		2.00
9	40031864	ASSY_COUNTER_WEIGHT				1.00
10	40024429	COUNTERWEIGHT		*		1.00
11	40004171	COUNTER_WEIGHT_SCREW		*		1.00
12	SM8081652TP	SCREW M8 L=16		*		1.00
13	SM8060552TP	SCREW M6 L=5		*		1.00
14	SM80606A2TP	SCREW M6 L=6		*		1.00
15	40029964	NEEDLE_BAR_CRANK_PIN				1.00
16	TA0490601R0	PLUG D=4.9X5.5 L=6				1.00
17	CQ303000000	COTTON OIL WICK D=3				0.03
18	40043322	TAKE_UP_LEVER_E_COATING				1.00
19	CQ202000000	COTTON OIL WICK D=2				0.30
20	22810907	RUBBER PLUG				1.00
21	40022678	TAKE_UP_LEVER_THRUST_PIN				1.00
22	CQ252000000	COTTON OIL WICK D=2.5				0.01
23	40098905	THREAD_TAKE_UP_LEVER_PIN_B				1.00
24	CQ202000000	COTTON OIL WICK D=2				0.04
25	40010470	SHUTTLE_ASM_SCREW				2.00
26	TA0500301R0	PLUG 5X5.8 L=3				1.00
27	TA0370301R0	PLUG D-3.7X4.4 L=3				1.00
28	40028116	MAIN_SHAFT_SPROCKET				1.00
29	SM80608A2TP	SCREW M6 L=8				2.00
30	SB120002500	BEARING				1.00
31	40091227	SERVO_MOTOR_550W				1.00
32	SL6052592TN	SCREW M5 L=25				4.00
33	40051473	COUPLING_ASM.				1.00

NEEDLE BAR & NEEDLE FEED COMPONENTS (FOR LH-4578C)

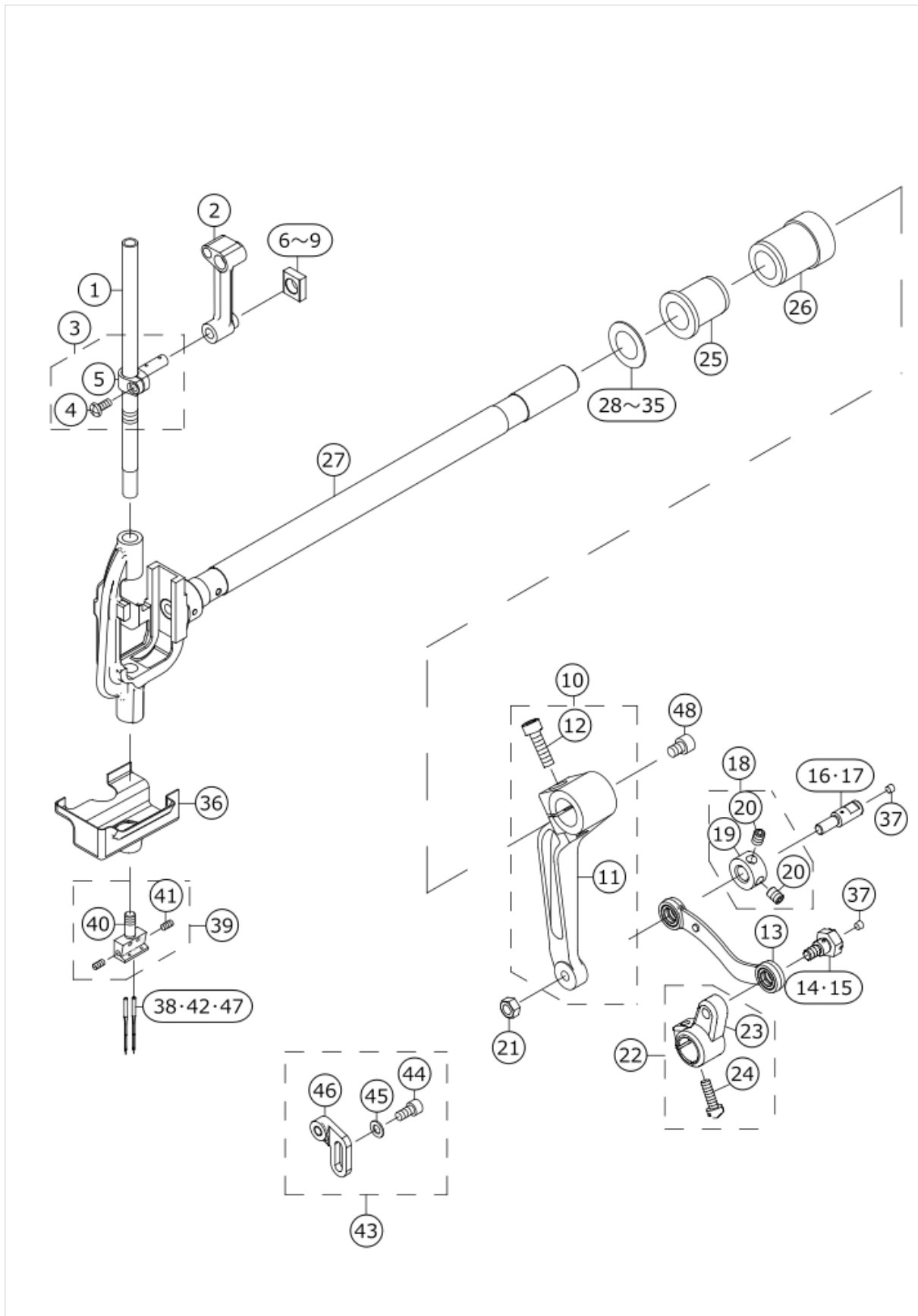

No.	品番	品名	備考	子部品	消耗品	個数
1	40236398	NEEDLE BAR				1.00
2	40030038	NEEDLE_BAR_CRANK_ROD				1.00
3	40031862	ASSY_NEEDLE_BAR_CONNECTION				1.00
4	SM4041055SP	SCREW		*		1.00
5	40040302	NEEDLE_BAR_CONNECTION		*		1.00
6	23204506	ROCKING ROD SQUARE BLOCK A	SELECTIVE PARTS			1.00
7	23204605	ROCKING ROD SQUARE BLOCK B	SELECTIVE PARTS			1.00
8	23204704	ROCKING ROD SQUARE BLOCK C	SELECTIVE PARTS			1.00
9	40065056	ROCKING_ROD_SQUARE_BLOCK_Z	SELECTIVE PARTS			1.00
10	40246973	ASSY_REAR_ARM				1.00
11	40246904	REAR_ARM		*		1.00
12	SM6062502TP	SCREW M6 L=25		*		1.00
13	40222682	DRIVING_ROD_ASM				1.00
14	40143358	SHOULDER_SCREW_A	SELECTIVE PARTS			1.00
15	40143359	SHOULDER_SCREW_B	SELECTIVE PARTS			1.00
16	40143360	THRUST_PIN_A	SELECTIVE PARTS			1.00
17	40143361	THRUST_PIN_B	SELECTIVE PARTS			1.00
18	CS087101BSH	THRUST COLLAR ASM. D=8.73 W=10				1.00
19	CS0871019SH	THRUST COLLAR D=8.73 W=10		*		1.00
20	SS8150822TP	SCREW 15/64-28 L=8		*		2.00
21	NM6060001CP	NUT M6X1 TYPE1				1.00
22	40028853	ASSY_DRIVING_ARM				1.00
23	40028282	DRIVING_ARM		*		1.00
24	SM6051600SP	SCREW M5 L=16		*		1.00
25	40023568	BUSHING				1.00
26	40221500	BUSHING				1.00
27	40236399	NEEDLE_BAR_ROCKING_BASE_ASM				1.00
28	B1438512B00	WASHER	SELECTIVE PARTS			1.00
29	22606206	SPACER Y	SELECTIVE PARTS			1.00
30	22606305	SPACER Z	SELECTIVE PARTS			1.00
31	22607600	SPACER A	SELECTIVE PARTS			1.00
32	22607709	SPACER B	SELECTIVE PARTS			1.00
33	22607808	SPACER D	SELECTIVE PARTS			1.00
34	22607907	SPACER E	SELECTIVE PARTS			1.00
35	22606404	SPACER F	SELECTIVE PARTS			1.00

36	40220121	OIL_GUARD_RUBBER				1.00
37	TA0370301R0	PLUG D-3.7X4.4 L=3				2.00
38	MDP500B1100	NEEDLE DPX5 #11	TYPE F			2.00
39	10148054	NEEDLE CLAMP ASM. 1/4				1.00
40	10148005	NEEDLE CLAMP 1/4		*		1.00
41	SS8080660TP	SCREW 1/8-44 L=5.5		*		2.00
42	MDP500B2100	NEEDLE DPX5 #21	TYPE G			2.00
43	40241162	PH=LOWER_FEED_COMPONENTS	OPTIONAL PARTS			1.00
44	SM6051002TP	SCREW M5X0.8 L=10	OPTIONAL PARTS	*		2.00
45	WP0550800SP	WASHER 5.5X10X0.8	OPTIONAL PARTS	*		2.00
46	40240348	ROCKING_ROD_FIXING_BLOCK	OPTIONAL PARTS	*		1.00
47	MDP500B1400	NEEDLE DPX5 #14	TYPE S			2.00
48	SM6060802TP	SCREW M6 L=8				1.00

NEEDLE BAR & NEEDLE FEED COMPONENTS (FOR LH-4588C)

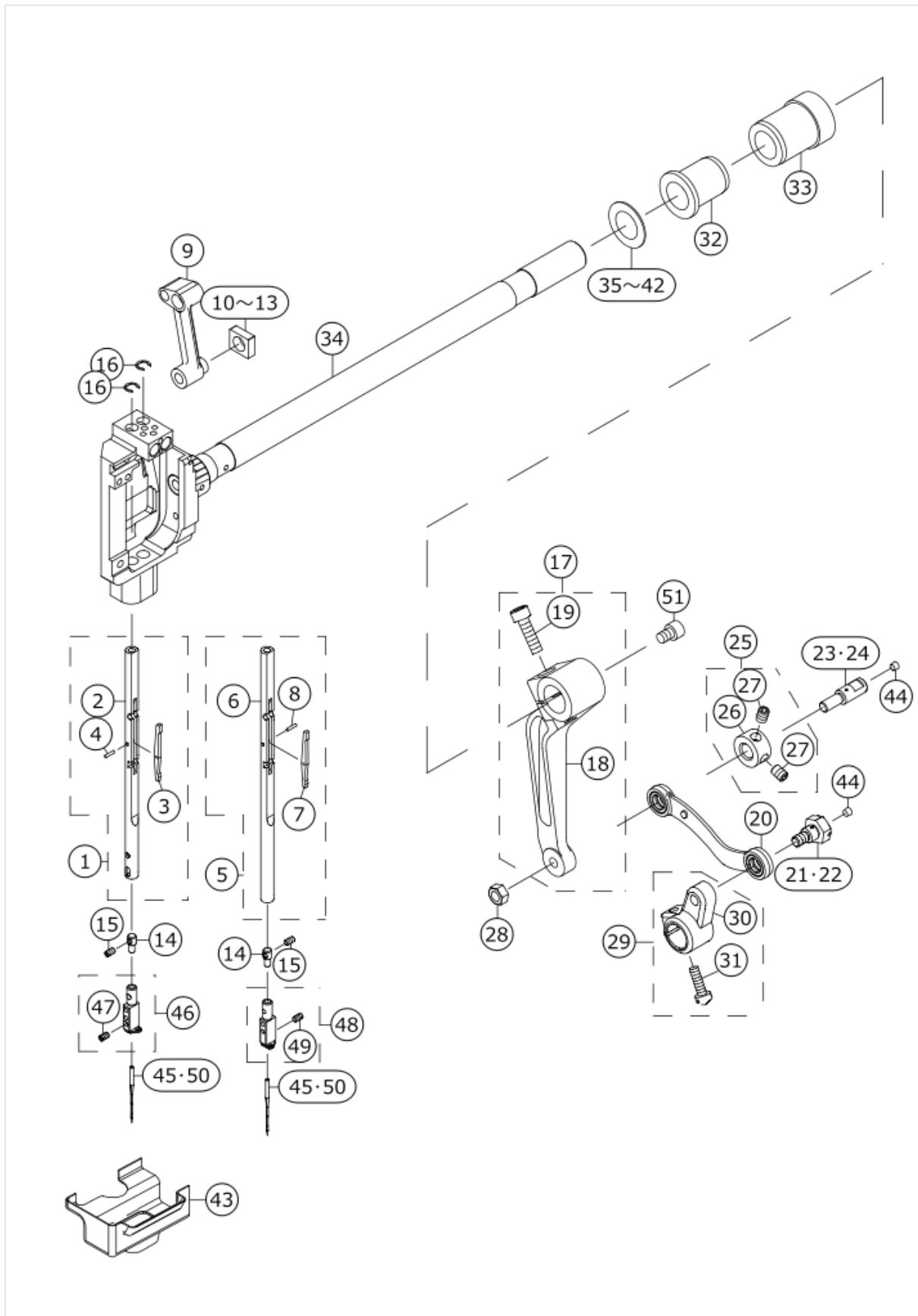

No.	品番	品名	備考	子部品	消耗品	個数
1	40026983	NEEDLE_BAR_ASM_LEFT				1.00
2	40026982	NEEDLE_BAR_LEFT		*		1.00
3	22685200	SEESAW PLATE		*		1.00
4	22685408	NEEDLE BAR PIN		*		1.00
5	40026984	NEEDLE_BAR_ASM_RIGHT				1.00
6	40026981	NEEDLE_BAR_RIGHT		*		1.00
7	22685200	SEESAW PLATE		*		1.00
8	22685408	NEEDLE BAR PIN		*		1.00
9	40030027	NEEDLE_BAR_CRANK_ROD				1.00
10	23204506	ROCKING ROD SQUARE BLOCK A	SELECTIVE PARTS			1.00
11	23204605	ROCKING ROD SQUARE BLOCK B	SELECTIVE PARTS			1.00
12	23204704	ROCKING ROD SQUARE BLOCK C	SELECTIVE PARTS			1.00
13	40065056	ROCKING_ROD_SQUARE_BLOCK_Z	SELECTIVE PARTS			1.00
14	22682504	SPRING BEARING				2.00
15	B1425526000	SCREW 1/8-44 L=6				4.00
16	40166315	RING_Z				2.00
17	40033669	ASSY_REAR_ARM				1.00
18	40032025	REAR_ARM		*		1.00
19	SM6062502TP	SCREW M6 L=25		*		1.00
20	40222682	DRIVING_ROD_ASM				1.00
21	40143358	SHOULDER_SCREW_A	SELECTIVE PARTS			1.00
22	40143359	SHOULDER_SCREW_B	SELECTIVE PARTS			1.00
23	40143360	THRUST_PIN_A	SELECTIVE PARTS			1.00
24	40143361	THRUST_PIN_B	SELECTIVE PARTS			1.00
25	CS087101BSH	THRUST COLLAR ASM. D=8.73 W=10				1.00
26	CS0871019SH	THRUST COLLAR D=8.73 W=10		*		1.00
27	SS8150822TP	SCREW 15/64-28 L=8		*		2.00
28	NM6060001CP	NUT M6X1 TYPE1				1.00
29	40028853	ASSY_DRIVING_ARM				1.00
30	40028282	DRIVING_ARM		*		1.00
31	SM6051600SP	SCREW M5 L=16		*		1.00
32	40023568	BUSHING				1.00
33	40221500	BUSHING				1.00
34	40220119	NEEDLE_BAR_ROCKING_BASE_ASM				1.00
35	B1438512B00	WASHER	SELECTIVE PARTS			1.00
36	22606206	SPACER Y	SELECTIVE PARTS			1.00
37	22606305	SPACER Z	SELECTIVE PARTS			1.00
38	22607600	SPACER A	SELECTIVE PARTS			1.00

39	22607709	SPACER B	SELECTIVE PARTS			1.00
40	22607808	SPACER D	SELECTIVE PARTS			1.00
41	22607907	SPACER E	SELECTIVE PARTS			1.00
42	22606404	SPACER F	SELECTIVE PARTS			1.00
43	40220120	OIL_GUARD_RUBBER				1.00
44	TA0370301R0	PLUG D-3.7X4.4 L=3				2.00
45	MDP500B2100	NEEDLE DPX5 #21	TYPE F			2.00
46	B1402528FALA	NEEDLE CLAMP ASM. 1/4				1.00
47	SS8080660TP	SCREW 1/8-44 L=5.5		*		1.00
48	B1402528FARA	NEEDLE CLAMP ASM. 1/4				1.00
49	SS8080660TP	SCREW 1/8-44 L=5.5		*		1.00
50	MDP500B1400	NEEDLE DPX5 #14	TYPE S			2.00
51	SM6060802TP	SCREW M6 L=8				1.00

PRESSER BAR COMPONENTS

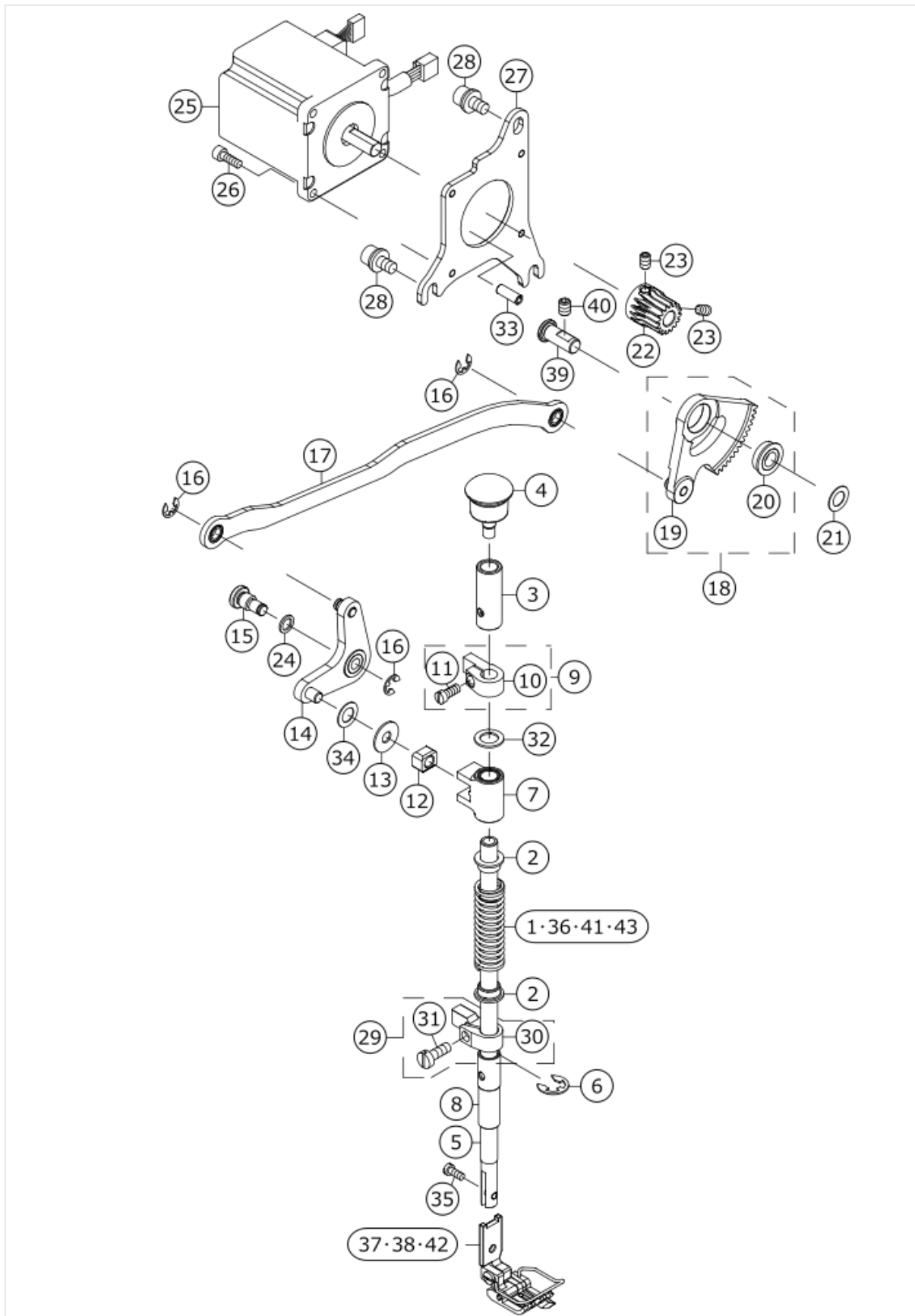

No.	品番	品吊	備考	子部品	消耗品	個数
1	40220091	PRESSER_SPRING_G	TYPE G			1.00
2	40172407	SPRING_GUIDE				2.00
3	40172408	BUSH_A				1.00
4	40172389	CAP				1.00
5	40220088	PRESSER_BAR				1.00
6	RE0800000K0	E-SHAPED SNAP RING (8MM)				1.00
7	40172410	PRESSER_GUIDE_BOSS_ASM				1.00
8	40172413	BUSH_B				1.00
9	40070531	PRESSER_BAR_CONNECTION_ASM.				1.00
10	26302901	PRESSER BAR HOLDER		*		1.00
11	SS7111110TP	SCREW 11/64-40 L=10.5		*		1.00
12	40141757	SQUARE_BLOCK				1.00
13	WP0621036SP	WASHER				1.00
14	40172425	ASSY_PRESSER_LINK_B				1.00
15	40172428	PRESSER_LINK_SCREW				1.00
16	RE0500000K0	E-RING				3.00
17	40221502	PRESSER_LINK_A_ASM				1.00
18	40226003	PRESSER_GEAR_COMP_N				1.00
19	40226004	PRESSER_GEAR_ASM_N		*		1.00
20	SB108000200	SIDE BEARING		*		1.00
21	WP0820526SD	WASHER 8.2X14X0.5				1.00
22	40200004	MOTOR_GEAR_N				1.00
23	SM80508A2TP	SCREW M5 L=8				2.00
24	WP0661016SP	WASHER				1.00
25	40220224	PRESSER_MOTOR				1.00
26	SM6041202TP	SCREW M4X0.7 L=12				4.00
27	40172466	MOTOR_BASE				1.00
28	SL6061292TN	SCREW M6 L=12				3.00
29	40086606	PRESSER_BAR_GUIDE_BRACKET_ASM.				1.00
30	40086607	PRESSER_BAR_GUIDE_BRACKET		*		1.00
31	SM6051400SP	SCREW		*		1.00
32	WP0951016SP	WASHER 9.53X15X1				1.00
33	PS0500142KP	SPRING PIN TYPE W 5X14				1.00
34	WP0820526SD	WASHER 8.2X14X0.5				1.00
35	SS7090910TP	SCREW 9/64-40 L= 8.5				1.00
36	40220093	PRESSER_SPRING_A	TYPE F			1.00
37	22647358	GUIDE PRESSER ASM. 1/4	TYPE F			1.00
38	40094776	ASSY_PRESSER_FOOT_G1/4	TYPE G			1.00
39	40172402	PRESSER_LEVER_SHAFT				1.00
40	SM80608A2TP	SCREW M6 L=8				1.00
41	40220092	PRESSER_SPRING_S	TYPE S			1.00
42	22640551	PRESSER FOOT ASM.	TYPE S			1.00
43	40220090	PRESSER_SPRING_G_OP	TYPE G OPTIONAL PARTS			1.00

CLOTH PRESSER SENSOR COMPONENTS

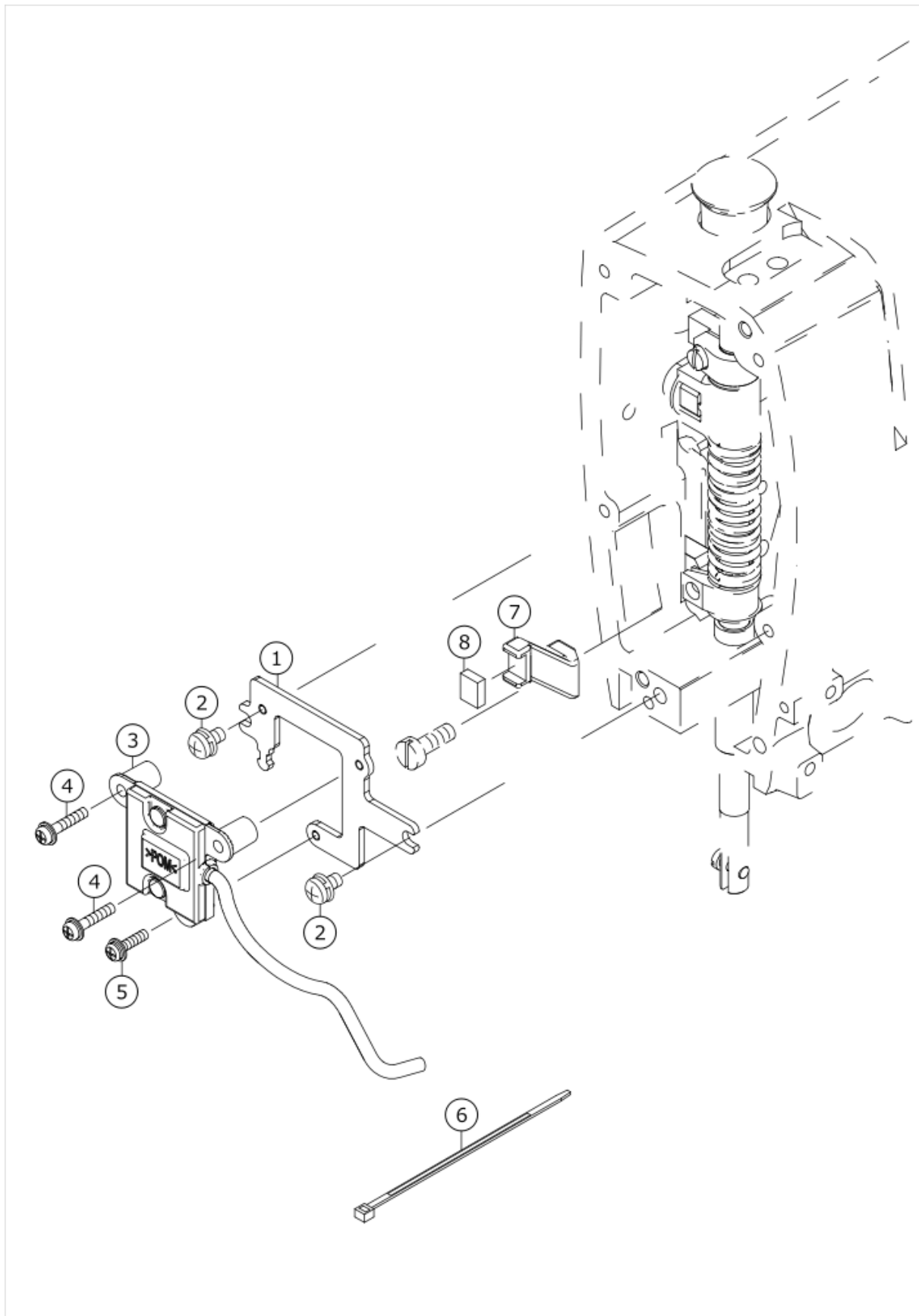

No.	品番	品名	備考	子部品	消耗品	個数
1	40220094	THICKNESS SENSOR BASE				1.00
2	SL4040891SC	SCREW M4 L=8				2.00
3	40192446	CLOTH_PRESSER_SENSOR_ASM				1.00
4	SL4031691SC	SCREW M3 L=16				2.00
5	SL4031291SC	SCREW M3 L=12				1.00
6	EA9500B0100	CABLE BAND				1.00
7	40220095	MAGNET HOLDER				1.00
8	40172415	MAGNET				1.00

No.	品番	品吊	備考	子部品	消耗品	個数
1	40220223	FEED_MOTOR				1.00
2	SL6041492TN	SCREW M4 L=14				4.00
3	40191618	THRUST_BEARING				1.00
4	40010278	MOTOR LINK				1.00
5	SM4051255SP	SCREW				1.00
6	SM80506A2TP	SCREW M5 L=6				1.00
7	40222685	FEED_PIN_B				1.00
8	40220108	FEED_LINK				1.00
9	40220110	FEED_AD_JOINT				1.00
10	SM80506A2TP	SCREW M5 L=6				4.00
11	40172451	FEED_LINK_METAL				1.00
12	40220102	FEED_AD_SHAFT				1.00
13	CS0800881TP	THRUST COLLAR D=8 W=8				1.00
14	SM80506A2TP	SCREW M5 L=6				2.00

REVERSE FEED LEVER COMPONENTS (FOR LH-4588-7/LH-4578-7)

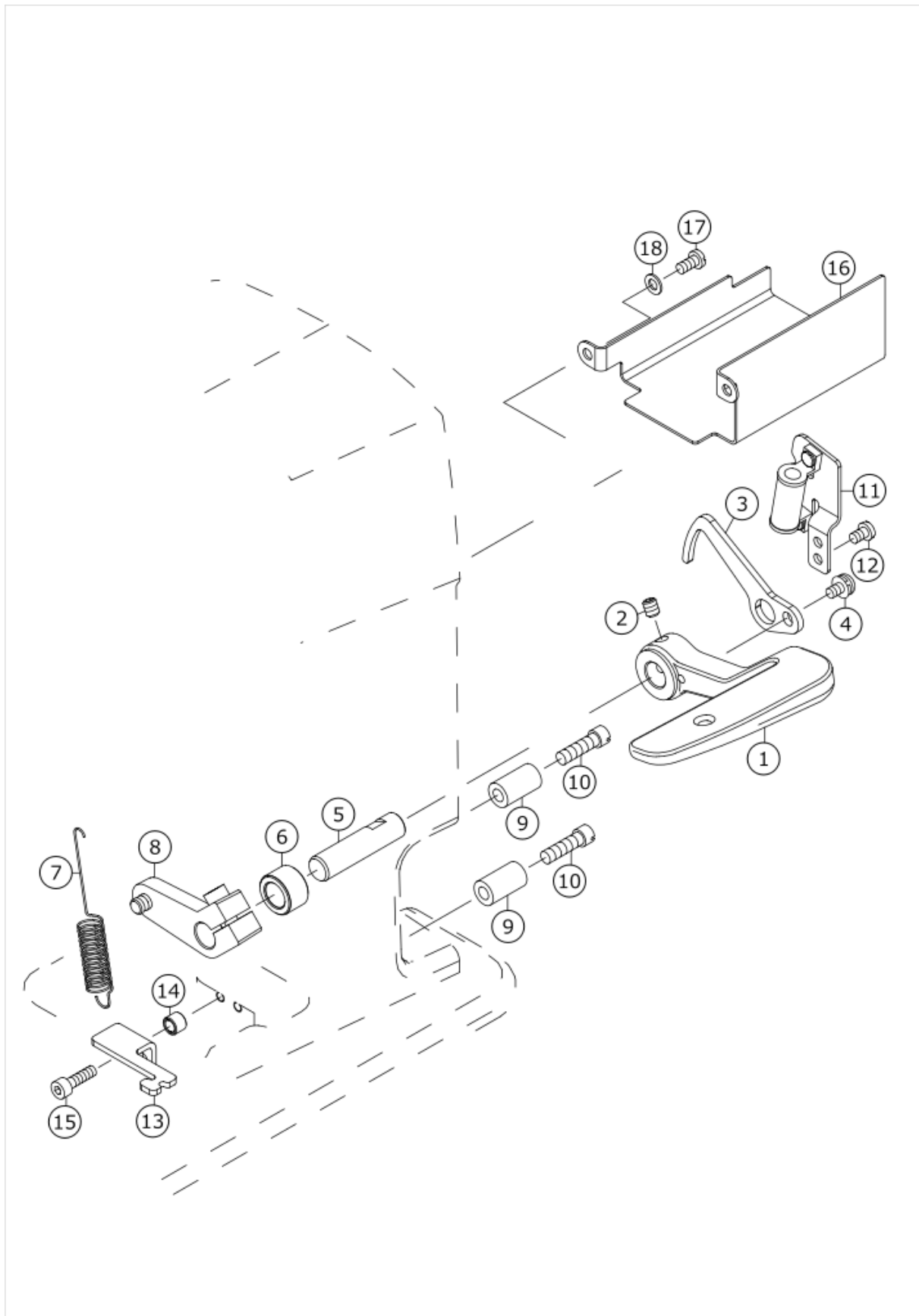

No.	品番	品名	備考	子部品	消耗品	個数
1	40172378	REVERSE_FEED_LEVER				1.00
2	SM80506A2TP	SCREW M5 L=6				1.00
3	40174291	FEED_CONTROL_SENSOR_PLATE				1.00
4	SL4040891SC	SCREW M4 L=8				1.00
5	40222886	FEED_LEVEL_SHAFT				1.00
6	40172510	FEED_LEVER_SHAFT_METAL				1.00
7	11050705	LEVER RETURN SPRING				1.00
8	40221498	ASSY_FEED_LEVER_ARM				1.00
9	22952501	BACK LEVER STOPPER				2.00
10	SM6051850TP	SCREW M5 L=18				2.00
11	40174405	FEED_CONTROL_SENSOR_BASE_ASM				1.00
12	SM4040655SP	SCREW				2.00
13	40091188	SPRING_BRACKET				1.00
14	40032582	COLLAR				2.00
15	SM6041402TP	SCREW M4 L=14				2.00
16	40222683	ANTI_INTERFERENCE_PLATE				1.00
17	SM4040855SP	SCREW				2.00
18	WP0430800SD	WASHER M4				2.00

THREAD TENSION COMPONENTS

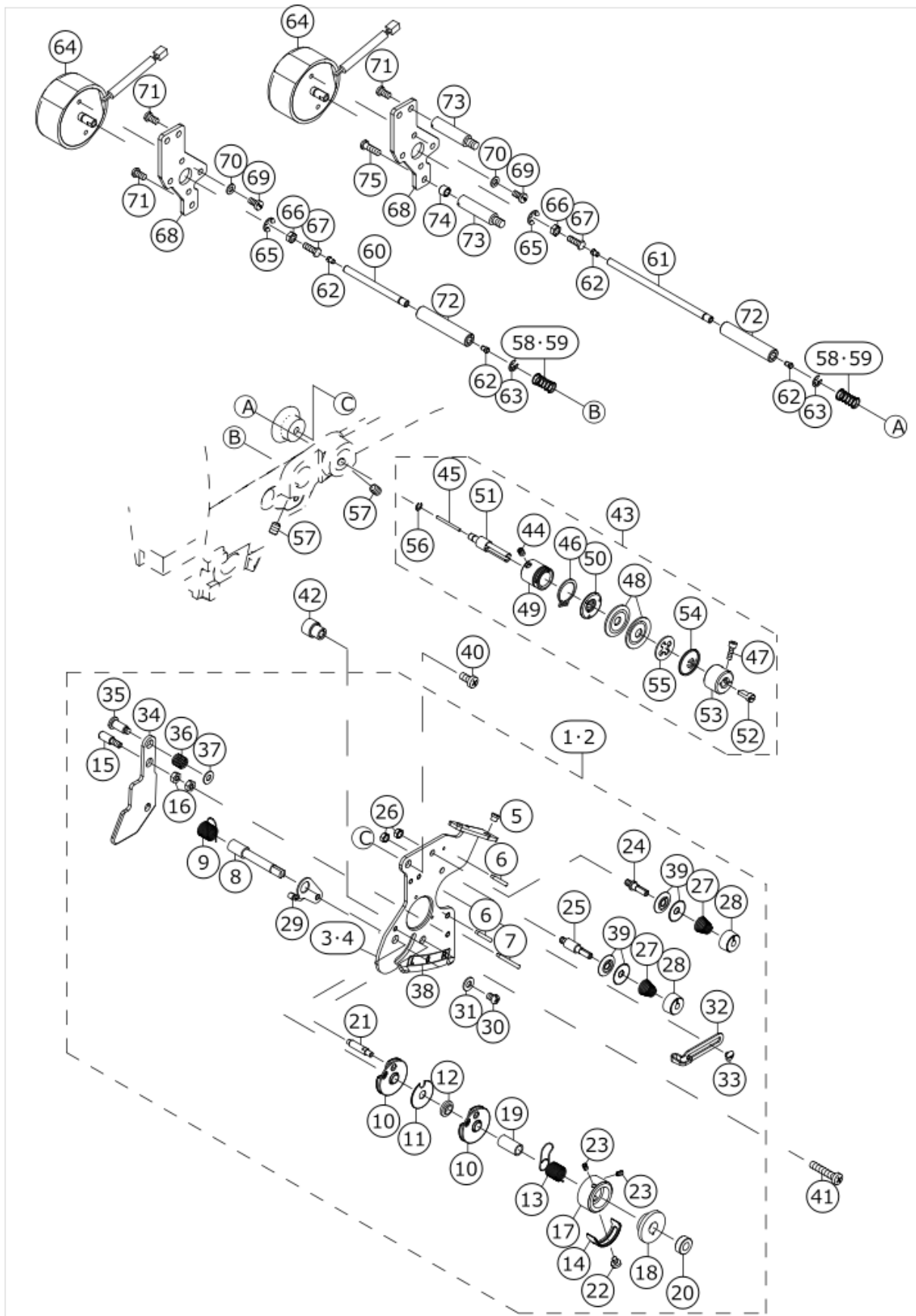

No.	品番	品名	備考	子部品	消耗品	個数
1	40220124	ASSY_TENSION_BASE_PLATE_88C	WITH ONE NEEDLE			1.00
2	40220125	ASSY_TENSION_BASE_PLATE_78C	WITHOUT ONE NEEDLE			1.00
3	40220126	TENSION_BASE_PLATE_88C	WITH ONE NEEDLE	*		1.00
4	40220261	TENSION_BASE_PLATE_78C	WITHOUT ONE NEEDLE	*		1.00
5	B1124804000	THREAD GUIDE		*		2.00
6	22617203	THREAD GUIDE PIN A		*		2.00
7	22617302	THREAD GUIDE PIN B		*		1.00
8	10697605	THREAD TAKE-UP SPRING STUD		*		1.00
9	22618706	THREAD TAKE-UP SPRING A		*		1.00
10	B31375270A0	TAKE-UP SPRING GUIDE ASM		*		2.00
11	B3142527000	TAKE-UP SPRING GUIDE PLATE		*		1.00
12	B3139527000	COLLAR		*		1.00
13	40256911	THREAD TAKE-UP SPRING B		*		1.00
14	B3138527000	ADJUSTING PLATE B		*		1.00
15	13474200	PIN_ROLLER_L	WITH ONE NEEDLE	*		1.00
16	NM6040001SC	NUT M4X0.7 TYPE1	WITH ONE NEEDLE	*		2.00
17	22617609	THREAD TENSION POST		*		1.00
18	22617708	TAKE-UP SPRING GUIDE		*		1.00
19	B3141527000	PRESSER_COLLAR		*		1.00
20	22617807	NUT		*		1.00
21	B3143527000	TAKE-UP SPRING GUIDE STUD		*		1.00
22	SS7090510SP	SCREW 9/64-40 L= 4.6		*		1.00
23	22618904	SET SCREW		*		2.00
24	40220254	THREAD_TENSION_POST_A		*		1.00
25	40220255	THREAD_TENSION_POST_B		*		1.00
26	NS6110310SP	HEXAGONAL NUT 11/64-40		*		2.00
27	11045101	THREAD TENSION SPRING		*		2.00
28	11072402	THREAD TENSION NUT		*		2.00
29	10697506	THREAD TENSION BRACKET		*		1.00
30	SS4110615SP	SCREW 11/64-40 L=6		*		1.00
31	WP0501016SD	WASHER 5X10.5X1		*		1.00
32	40083824	THREAD_TAKE_UP_GUIDE_B		*		1.00
33	SS5090420SP	SCREW 9/64-40 L=3.5		*		2.00
34	40220139	REPOSITION_RELEASE_LEVER	WITH ONE NEEDLE	*		1.00
35	SD0601171SP	SHOULDER SCREW D=6 H=11.7	WITH ONE NEEDLE	*		1.00
36	B1449526000	REPOSITIONING LEVER SPRING	WITH ONE NEEDLE	*		1.00
37	WP0450801SP	WASHER	WITH ONE NEEDLE	*		1.00
38	40091267	TENSION_PLATE_LABEL	WITH ONE NEEDLE	*		1.00
39	10741106	FIRST THREAD TENSION PLATE		*		4.00

40	SM4051001SN	SCREW M5				1.00
41	SM4052501SN	SCREW M5X0.8 L=25				1.00
42	40091193	STUD				1.00
43	40220127	THREAD_TENSION_ASM				2.00
44	SM8040612TP	SCREW M4 L=6		*		1.00
45	B3118552H00	THREAD RELEASE PIN		*		1.00
46	RC1700001KP	C-RING 17 (15.7)		*		1.00
47	SM6031002TN	SCREW M3 L=10		*		1.00
48	22921506	THREAD TENSION DISK		*		2.00
49	40174313	TENSION_POST_BASE_ASM		*		1.00
50	40126724	TENSION_DISC_HOLDER		*		1.00
51	40172472	AT_SHAFT		*		1.00
52	40172473	DISK_STOPPER_HOLDER_CAP_PIN		*		1.00
53	40172474	DISK_STOPPER_HOLDER_CAP		*		1.00
54	B3132012000	TENSION DISC HOLDER		*		1.00
55	40174312	THREAD_TENSION_DISK_RUBBER		*		1.00
56	RC0410415KP	C-RING (4.09)		*		1.00
57	SM80608A2TP	SCREW M6 L=8				2.00
58	22920409	THREAD RELEASE PIN SPRING	TYPE G			2.00
59	40056970	NB_FRAME_SHAFT_SPRING	TYPE F AND TYPE S			2.00
60	40220128	THREAD_TENSION_SHAFT_LEFT				1.00
61	40173734	THREAD_TENSION_SHAFT				1.00
62	26201004	GUIDE PIN				4.00
63	RE0400000K0	E-RING 4				2.00
64	40174350	AT_SOLENOID_A				2.00
65	RE0500000K0	E-RING				2.00
66	NM6040000SN	NUT M4 TYPE1				2.00
67	40174311	SCREW				2.00
68	40222893	AT_SOLENOID_PLATE				2.00
69	SM7040800SL	SCREW				4.00
70	WP0410846SC	WASHER				4.00
71	SS4110815SP	SCREW 11/64-40 L=8				5.00
72	40220134	AT_SHAFT_BUSHING				2.00
73	22924005	PUMP BODY STRUT				3.00
74	40032582	COLLAR				1.00
75	SS4111415SP	SCREW 11/64-40 L=14				1.00

NEEDLE CHANGE COMPONENTS (WITH ONE NEEDLE)

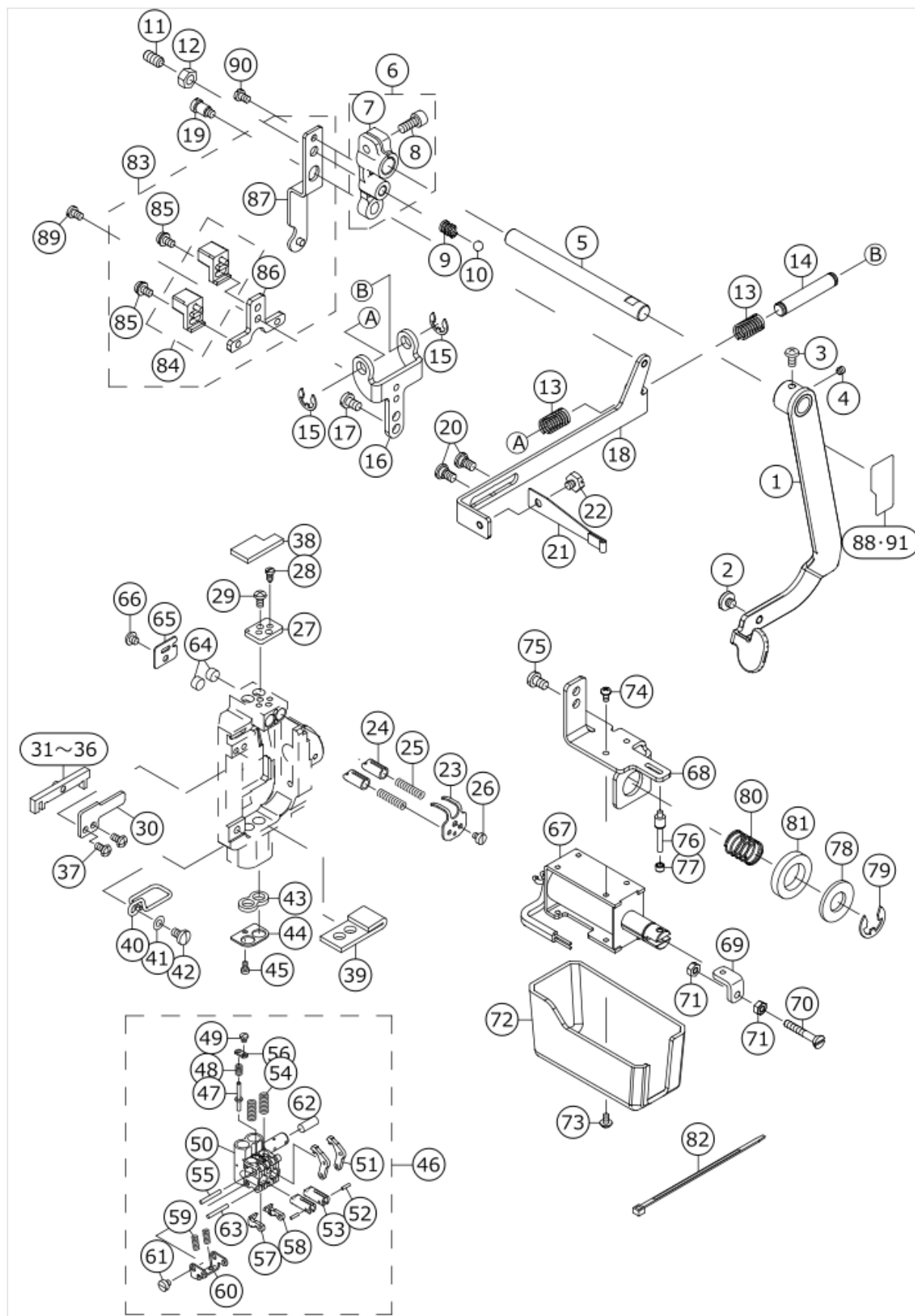

No.	品番	品名	備考	子部品	消耗品	個数
1	40220136	ASSY_REPOSITIONING_LEVER				1.00
2	SM6050450TP	SCREW M5 L=4				1.00
3	SM4040855SP	SCREW				1.00
4	SM8040412TP	SCREW M4X4				1.00
5	40028844	REPOSITIONING_LEVER_SHAFT				1.00
6	40220146	ASSY_REPOSITIONING_ARM				1.00
7	40220147	REPOSITIONING_ARM		*		1.00
8	SM6051202TP	SCREW M5X0.8 L=12		*		1.00
9	40028641	ADJUSTING_SPRING				1.00
10	22615702	OIL ADJUSTING BALL				1.00
11	SM8061212TP	SCREW M6X12				1.00
12	NM6060001CP	NUT M6X1 TYPE1				1.00
13	22687503	SPRING				2.00
14	22687701	SPRING SHAFT				1.00
15	RE0700000K0	E-RING 7				2.00
16	40220148	SPRING_BASE				1.00
17	SM4050855SP	SCREW				2.00
18	40220138	TRANSFORM_PLATE				1.00
19	SD0640752TP	SHOULDER SCREW D=6.35 H=7.5				1.00
20	SD0640247TP	SHOULDER SCREW D=6.35 H=2.4				2.00
21	22687008	LEAF SPRING				1.00
22	SS9110460CP	SCREW 11/64-40 L=4				1.00
23	40095222	STOPPER_SPRING_COVER				1.00
24	22681407	NEEDLE BAR STOPPER				2.00
25	22681506	SPRING				2.00
26	SS6080410SP	SCREW 1/8-44 L=4				1.00
27	22682702	NEEDLE BAR SWIVEL STOPPER				1.00
28	22681712	STOPPER SCREW				2.00
29	SS4090715SP	SCREW 9/64-40 L=7				2.00
30	22681803	SLIDE BLOCK GUIDE PLATE				1.00
31	22681951	SLIDER BLOCK ASM. A	SELECTIVE PARTS			1.00
32	22682058	SLIDER BLOCK ASM. B	SELECTIVE PARTS			1.00
33	22682157	SLIDER BLOCK ASM. C	SELECTIVE PARTS			1.00
34	22682256	SLIDER BLOCK ASM. D	SELECTIVE PARTS			1.00
35	22682355	SLIDER BLOCK ASM. E	SELECTIVE PARTS			1.00
36	40117425	SLIDER BLOCK ASM. F	SELECTIVE PARTS			1.00
37	SS4090715SP	SCREW 9/64-40 L=7				2.00
38	40039629	FELT				1.00
39	22686109	OIL_GUARD_FELT				1.00
40	22685903	FELT GUIDE				1.00
41	WP0450000SD	WASHER 4.5X8X0.5				1.00
42	SS7110710SP	SCREW 11/64-40 L=7				1.00
43	22686000	NEEDLE BAR OIL SEAL FELT				1.00
44	22685804	NEEDLE BAR OIL SEAL PLATE				1.00

45	SS6060510TP	SCREW 3/32-56 L=4.5				1.00
46	40032147	NEEDLE_BAR_CONNECTION_ASM				1.00
47	40024473	RELEASE_PIN		*		1.00
48	22683304	SPRING		*		1.00
49	SS7060310SP	SCREW 3/32-56 L=3		*		1.00
50	40028679	NEEDLE_BAR_CONNECTION		*		1.00
51	22683601	CLUTCH LEVER		*		2.00
52	B1705850000	STOPPER PIN		*		2.00
53	40024064	NEEDLE_BAR_CLUTCH		*		2.00
54	22683809	SPRING		*		2.00
55	22683403	NEEDLE BAR CONNECTION PIN		*		1.00
56	40015144	NEEDLE BAR CONNECTION PIN		*		1.00
57	22683908	CLUTCH STOPPER		*		1.00
58	22684005	CLUTCH STOPPER		*		1.00
59	22684104	SPRING		*		2.00
60	22684203	SPRING BRACKET		*		1.00
61	SS6080340SP	SCREW 1/8-44 L=2.9		*		2.00
62	CQ252000000	COTTON OIL WICK D=2.5		*		0.03
63	40059036	RELEASE_PIN_COVER		*		1.00
64	11002904	ROLLER FELT				2.00
65	22681209	FELT COVER				1.00
66	SS6090420SP	SCREW 9/64-40 L= 4.0				1.00
67	40220144	REPOSITION_SOLENOID				1.00
68	40220141	SOLENOID_BASE_PLATE				1.00
69	40220140	LEVER_PIN_LINK				1.00
70	40220142	LEVER_PIN				1.00
71	NM6040001SC	NUT M4X0.7 TYPE1				2.00
72	40220135	SOLENOID_COVER				1.00
73	SL4030631SC	SCREW M3 L=6				2.00
74	SL4030641SE	SCREW M3 L=6				3.00
75	SM4050855SP	SCREW				2.00
76	22957104	WIPER SOLENOID SHAFT				1.00
77	22957203	WIPER LINK COLLAR				1.00
78	WP1252210SC	WASHER 12.5X25.6X2.2				1.00
79	RE1000000K0	E-RING 10				1.00
80	40220145	PLUNGER_REPOSITION_SPRING				1.00
81	D2468555B00	RUBBER PLUNGER				1.00
82	EA9500B0100	CABLE BAND				1.00
83	40221499	LEVER_SENSOR_ASM				1.00
84	40220225	SENSOR CABLE ASSY		*		1.00
85	SL4040881SC	SCREW M4 L=8		*		2.00
86	40220149	SENSOR_PLATE		*		1.00
87	40220143	MAGNTIE_FIXED_PLATE		*		1.00
88	CM300400901	LABEL_04_C	FOR CHINA			1.00
89	SM4040655SP	SCREW				2.00
90	SM4040655SP	SCREW				1.00
91	CM300400902	LABEL_04	EXCEPT CHINA			1.00

No.	品番	品名	備考	子部品	消耗品	個数
1	40031348	ASSY_FD_ECCENTRIC_CAM				1.00
2	40011905	FD_ECCENTRIC_CAM		*		1.00
3	SM80608A2TP	SCREW M6 L=8		*		2.00
4	SM4051255SP	SCREW		*		1.00
5	NM6050001SP	NUT M5X0.8 TYPE1		*		1.00
6	B1636581B00	NEEDLE BEARING B				1.00
7	40011906	FD_CAM_LID				1.00
8	SM4040855SP	SCREW				2.00
9	40032293	ASSY_FEED_ROCKER_ROD				1.00
10	40028273	FEED_ROCKER_ROD		*		1.00
11	B1653470000	PIN		*		1.00
12	SM8040412TP	SCREW M4X4		*		1.00
13	40222678	ASSY_FEED_ROCKER_ARM				1.00
14	SM6051600SP	SCREW M5 L=16		*		1.00
15	40222679	FEED_ROCKER_ARM		*		1.00
16	NM6060001CP	NUT M6X1 TYPE1				1.00
17	SD0900706TP	SHOULDER SCREW D=9 H=7				1.00
18	40241281	FEED_ROCKER_SHAFT				1.00
19	40011939	FEED_SHAFT_BUSH_F				1.00
20	40028280	FEED_SHAFT_BUSH_R				1.00
21	40013362	FEED_SHAFT_OIL_SEAL_A				1.00
22	40025316	FEED_SHAFT_OIL_SEAL_B				1.00
23	40032268	THRUST COLLAR				2.00
24	CS1501181TP	THRUST COLLAR D=15 W=11		*		1.00
25	SM8050412TP	SCREW M5 L=4		*		2.00
26	SM80606A2TP	SCREW M6 L=6				1.00
27	40220096	FEED_ROCKER_ROD				1.00
28	40220107	FEED_ADJUSTING_ARM				1.00
29	SM7050850TP	SCREW M5 L=8				2.00
30	40220111	SLIDER_BASE_ARC				1.00
31	SD0900426TP	SHOULDER SCREW D=9 H=4.2				1.00
32	40220112	FEED ADJUSTING STOPPER				1.00
33	40028291	FEED_ADJUSTING_OIL_SEAL				1.00
34	40028294	FEED_ADJUSTING_CAP				1.00
35	40031349	ASSY_FEED_BASE_ARM				1.00
36	40011931	FEED_BASE_ARM		*		1.00
37	SM6051400SP	SCREW		*		1.00
38	40011932	FEED_BASE_SHAFT				1.00
39	SM8040612TP	SCREW M4 L=6				1.00
40	40031350	ASSY_FEED_BASE_SHAFT_COLLAR				1.00
41	40011933	FEED_BASE_SHAFT_COLLAR		*		1.00
42	SM8040412TP	SCREW M4X4		*		2.00
43	SM8031612TP	SET SCREW M3X16				1.00
44	NM6030001SN	NUT M3X0.5 TYPE1				1.00
45	40220204	SCREW				2.00
46	40220100	FEED_BASE	WITHOUT TRIM			1.00
47	40220099	FEED_BASE_TRIM	WITH TRIM			1.00
48	SM6041002TP	SCREW M4X0.7 L=10				4.00
49	40220104	ASSY_SLIDER_ARC				2.00
50	40220106	FEED_ADJUSTING_BLOCK_ARC		*		1.00

51	40220105	SLIDER_ARC		*		1.00
52	40169698	VERTICAL_FEED_CAM				1.00
53	SM80606A2TP	SCREW M6 L=6				2.00
54	SB117000700	BEARING				1.00
55	40220115	VERTICAL_FEED_ROD				1.00
56	SM6062502TP	SCREW M6 L=25				1.00
57	40154833	VERTICAL_FEED_COLLAR				1.00
58	26018705	WASHER				1.00
59	40154832	VERTICAL_FEED_ROD_NUT				1.00
60	40126359	VERTICAL_FEED_ROD_BUSH				1.00
61	40125843	VERTICAL_FEED_ARM_REAR				1.00
62	SM80606A2TP	SCREW M6 L=6				2.00
63	B125578100A	WASHER A				1.00
64	RC0150001KP	C-RING 15 (13.8)				1.00
65	40169686	FEED ROCKER SHAFT BUSHING				2.00
66	40222676	ASSY_VERTICAL_FD_ARM_FRONT				1.00
67	SM6061602TP	SCREW M6 L=16		*		1.00
68	40222675	VERTICAL_FD_ARM_FRONT		*		1.00
69	SM8040412TP	SCREW M4X4				1.00
70	40220116	FEED_BASE_DRIVING_LINK				1.00
71	SM8040612TP	SCREW M4 L=6				1.00
72	40220117	VERTICAL_FEED_LINK_SHAFT				2.00
73	CQ202000000	COTTON OIL WICK D=2				0.05
74	40220103	VERTICAL_FEED_SHAFT				1.00
75	22904155	MAIN SHAFT THRUST COLLAR ASM.				1.00
76	22904106	MAIN SHAFT THRUST COLLAR		*		1.00
77	SS8660610TP	SCREW 1/4-40 L=6		*		2.00
78	40033566	FEED_DOG_TYPE_F_1/4	TYPE F			1.00
79	40035892	FEED_DOG_TYPE_7G_1/4	TYPE G			1.00
80	40061274	FEED_DOG_TYPE-S 1/4	TYPE S(WITH TRIM)			1.00
81	22630602	FEED DOG 1/4	TYPE S(WITHOUT TRIM)			1.00

HOOK DRIVING SHAFT COMPONENTS

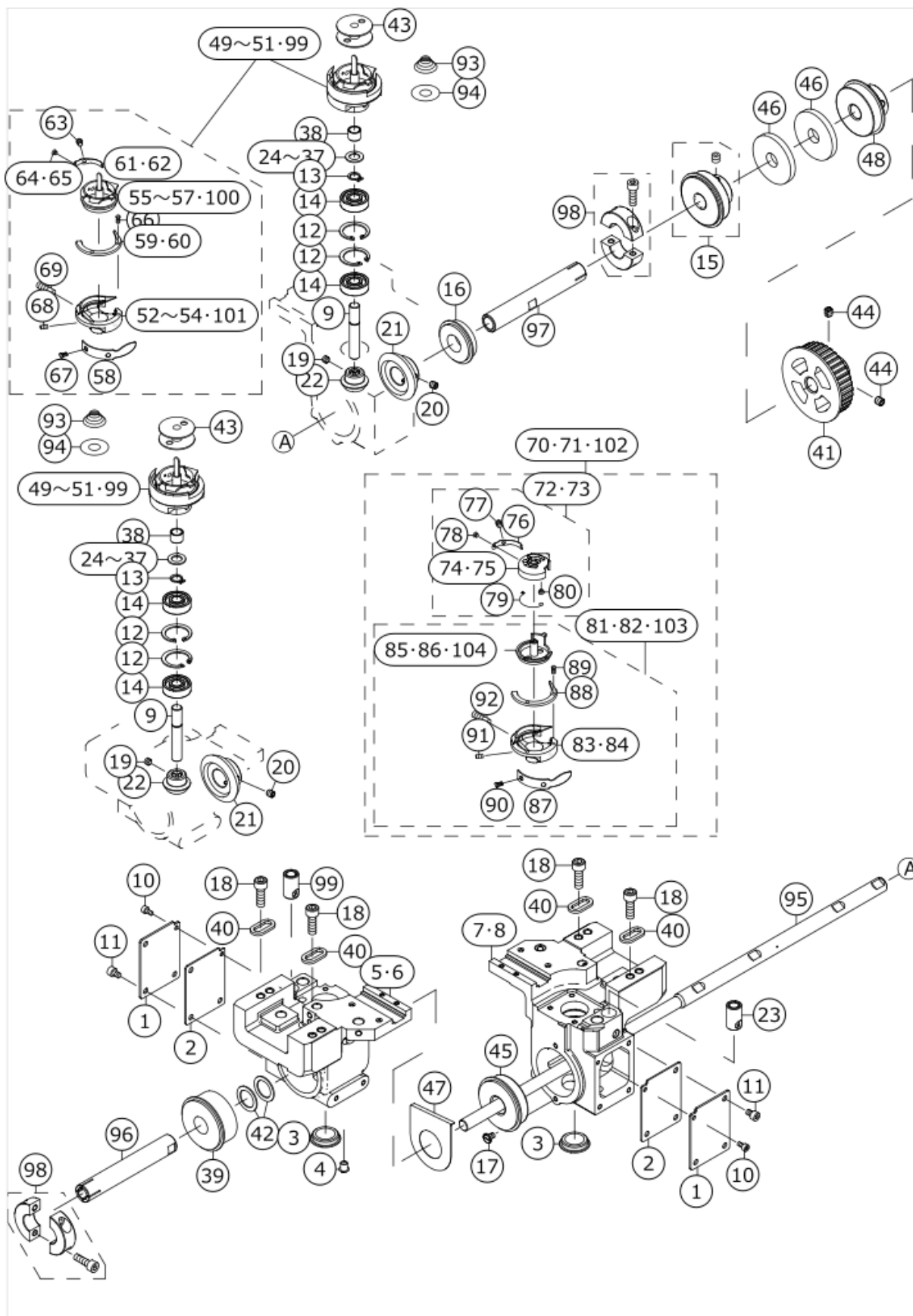

No.	品番	品名	備考	子部品	消耗品	個数
1	40220172	HOOK_SHAFT_BASE_SIDE_PLATE				2.00
2	40220173	HOOK_SHAFT_BASE_COVER_PACKING				2.00
3	TA2050406R0	RUBBER PLUG				2.00
4	TA0550604R0	RUBBER PLUG				1.00
5	40220174	HOOK_SHAFT_BASE_LEFT_TRIM	FOR LH-4578C-7 ,LH-4588C-7(WI TH TRIM)			1.00
6	40220176	HOOK_SHAFT_BASE_LEFT	FOR LH-4578C (WITHOUT TRIM) TYPE F			1.00
7	40220175	HOOK_SHAFT_BASE_RIGHT_TRIM	FOR LH-4578C-7 ,LH-4588C-7(WI TH TRIM)			1.00
8	40220177	HOOK_SHAFT_BASE_RIGHT	FOR LH-4578C (WITHOUT TRIM) TYPE F			1.00
9	40220180	HOOK_SHAFT				2.00
10	SM6030602TP	SCREW M3X0.5 L=6				2.00
11	SM6040602TP	SCREW M4X0.7 L=6				6.00
12	RC2351018KP	C-RING 22 (18.7)				4.00
13	RC0740816K0	C-RING 8 (7.4)				2.00
14	40220246	BEARING				4.00
15	40241282	LOWER_SHAFT_BEARING				1.00
16	40229554	RIGHT_HOOK_BASE_BEARING_R				1.00
17	SM6040650TP	SCREW				2.00
18	SM6061802TP	SCREW M6 L=18				4.00
19	SM8050412TP	SCREW M5 L=4				4.00
20	SM80506A2TP	SCREW M5 L=6				4.00
21	40126372	LOWER_SHAFT_GEAR				2.00
22	40112242	HOOK_SHAFT_GEAR				2.00
23	40220183	BUSHING_OIL_ADJ				2.00
24	B255728000A	WASHER A	SELECTIVE PARTS			2.00
25	B255728000B	WASHER B	SELECTIVE PARTS			2.00
26	B255728000C	WASHER C	SELECTIVE PARTS			2.00
27	B255728000D	WASHER D	SELECTIVE PARTS			2.00
28	B255728000E	WASHER E	SELECTIVE PARTS			2.00
29	40138418	WASHER_T=1.3	SELECTIVE PARTS			2.00
30	40138419	WASHER_T=1.4	SELECTIVE PARTS			2.00
31	40138420	WASHER_T=1.5	SELECTIVE PARTS			2.00
32	40138421	WASHER_T=1.6	SELECTIVE PARTS			2.00
33	40138422	WASHER_T=1.7	SELECTIVE PARTS			2.00

34	40138423	WASHER_T=1.8	SELECTIVE PARTS			2.00
35	40143185	WASHER_T=0.5	SELECTIVE PARTS			2.00
36	40143188	WASHER_T=0.6	SELECTIVE PARTS			2.00
37	40143581	WASHER_T=0.7	SELECTIVE PARTS			2.00
38	40126382	HOOK_SHAFT_COLLAR				2.00
39	SB115002200	BEARING				1.00
40	40220182	HOOK_SHAFT_BASE_WASHER				4.00
41	40227964	LOWER_SHAFT_SPROCKET				1.00
42	B122177100F	MAIN SHAFT THRUST WASHER (F)				2.00
43	40235203	BOBBIN				2.00
44	SM80606A2TP	SCREW M6 L=6				2.00
45	40229551	RIGHT_HOOK_BASE_BEARING_L				1.00
46	23618804	OIL SEAL				2.00
47	40220181	OIL_BLOCK_PLATE				1.00
48	40150033	LOWER_SHAFT_BEARING				1.00
49	40220166	ASSY_RATCH_LARGEHOOK_TRIM	FOR LH-4578C-7 TYPE G			2.00
50	40220171	RATCH-HOOK-F-3.7	FOR LH-4578C (WITHOUT TRIM) TYPE F			2.00
51	40242190	ASSY_RATCH_LARGEHOOK_TRIM_S	FOR LH-4578C-7 (WITH TRIM) TYPE S			2.00
52	40240677	OUTER_HOOK	TYPE G	*		1.00
53	40247002	OUTER_HOOK	FOR LH-4578C (WITHOUT TRIM) TYPE F	*		1.00
54	40242599	OUTER_HOOK_S	TYPE S (WITH TRIM)	*		1.00
55	40240717	INNER_HOOK	FOR LH-4578C-7 TYPE G	*		1.00
56	40240713	INNER_HOOK	FOR LH-4578C (WITHOUT TRIM) TYPE F	*		1.00
57	40242601	INNER_HOOK_RATCH_S	FOR LH-4578C-7 (WITH TRIM) TYPE S	*		1.00
58	40240679	NEEDLE HOLDER		*		1.00
59	40240718	INNER_HOOK HOLDER	FOR LH-4578C-7 ,LH-4588C-7(WITH TRIM)	*		1.00
60	40240714	INNER_HOOK HOLDER	FOR LH-4578C (WITHOUT TRIM) TYPE F	*		1.00
61	40240719	TENSION_ADJUSTING_SPRING(0.5)	FOR LH-4578C-7 (WITH TRIM)	*		1.00
62	40240715	TENSION_ADJUSTING_SPRING(0.4)	FOR LH-4578C (WITHOUT TRIM) TYPE F	*		1.00

63	40240720	ADJUSTING_SCREW	FOR LH-4578C	*		1.00
64	40240684	TENSION_SPRING_SET_SCREW	FOR LH-4578C-7 .LH-4588C-7(WI TH TRIM)	*		1.00
65	40240716	TENSION_SPRING_SET_SCREW	FOR LH-4578C (WITHOUT TRIM) TYPE F	*		1.00
66	40240700	INNER_HOOK_PRESSER_SCREW		*		3.00
67	40240701	NEEDLE HOLDER_SET_SCREW		*		2.00
68	40240702	HOOK_SCREW		*		2.00
69	40240703	NEEDLE HOLDER_ADJUSTING_SCREW		*		1.00
70	40220167	ASSY_CAP_LARGEHOOK_TRIM	FOR LH-4588C-7 TYPE G OPTION AL(THREAD #3)			2.00
71	40242130	ASSY_CAP_LARGEHOOK_TRIM_S	FOR LH-4588C-7 TYPE S			2.00
72	40242064	BOBBIN_CASE_ASM	FOR LH-4588C-7 TYPE G	*		1.00
73	40242604	BOBBIN_CASE_ASM_S	FOR LH-4588C-7 TYPE S	*		1.00
74	40240709	CAP	FOR LH-4588C-7 TYPE G OPTION AL(THREAD #3)	*		1.00
75	40242602	CAP_S	FOR LH-4588C-7 TYPE S,LH-458 8C-7 TYPE G	*		1.00
76	40240681	TENSION_ADJUSTING_SPRING(0.4)	FOR LH-4588C-7	*		1.00
77	40240682	ADJUSTING_SCREW	FOR LH-4588C-7	*		1.00
78	40240684	TENSION_SPRING_SET_SCREW	FOR LH-4578C-7 .LH-4588C-7(WI TH TRIM)	*		1.00
79	40240710	SPRING	FOR LH-4588C-7	*		1.00
80	40240711	LOWER_THREAD_SCREW	FOR LH-4588C-7	*		1.00
81	40242063	LARGEHOOK_TRIM_EXCEPT_CAP	FOR LH-4588C-7 TYPE G OPTION AL(THREAD #3)	*		1.00
82	40242603	LARGEHOOK_TRIM_EXCEPT_CAP_S	FOR LH-4588C-7 TYPE S	*		1.00
83	40240677	OUTER_HOOK	TYPE G	*		1.00
84	40242599	OUTER_HOOK_S	TYPE S (WITH TRIM)	*		1.00
85	40240678	INNER_HOOK	FOR LH-4588C-7 TYPE G OPTION AL(THREAD #3)	*		1.00
86	40242600	INNER_HOOK_CAP_S	FOR LH-4588C-7 TYPE S	*		1.00
87	40240679	NEEDLE HOLDER		*		1.00
88	40240718	INNER_HOOK HOLDER	FOR LH-4578C-7 .LH-4588C-7(WI TH TRIM)	*		1.00
89	40240700	INNER_HOOK_PRESSER_SCREW		*		3.00

90	40240701	NEEDLE HOLDER_SET_SCREW		*		2.00
91	40240702	HOOK_SCREW		*		2.00
92	40240703	NEEDLE HOLDER_ADJUSTING_SCREW		*		1.00
93	40055358	SPRING_L	FOR LH-4578C-7 .LH-4588C-7(WI TH TRIM)			2.00
94	22819809	SHEET	FOR LH-4578C-7 .LH-4588C-7(WI TH TRIM)			2.00
95	40220186	LOWER_SHAFT_LH4500C				1.00
96	40220187	LOWER_SHAFT_D				1.00
97	40112253	LOWER_SHAFT_C				1.00
98	40152295	LOWER_SHAFT_SET_COLLAR				2.00
99	40246970	RATCH_HOOK-S	FOR LH-4578C (WITHOUT TRIM) TYPE S			2.00
100	40247001	INNER_HOOK	FOR LH-4578C (WITHOUT TRIM) TYPE S	*		1.00
101	40247002	OUTER_HOOK	FOR LH-4578C (WITHOUT TRIM) TYPE S	*		1.00
102	40260052	ASSY_CAP_LARGEHOOK_TRIM_ST	FOR LH-4588C-7 TYPE G			2.00
103	40260056	LARGEHOOK_TRIM_EXCEPT_CAP_ST	FOR LH-4588C-7 TYPE G	*		2.00
104	40260053	INNER_HOOK	FOR LH-4588C-7 TYPE G	*		2.00

OPENNER COMPONENTS

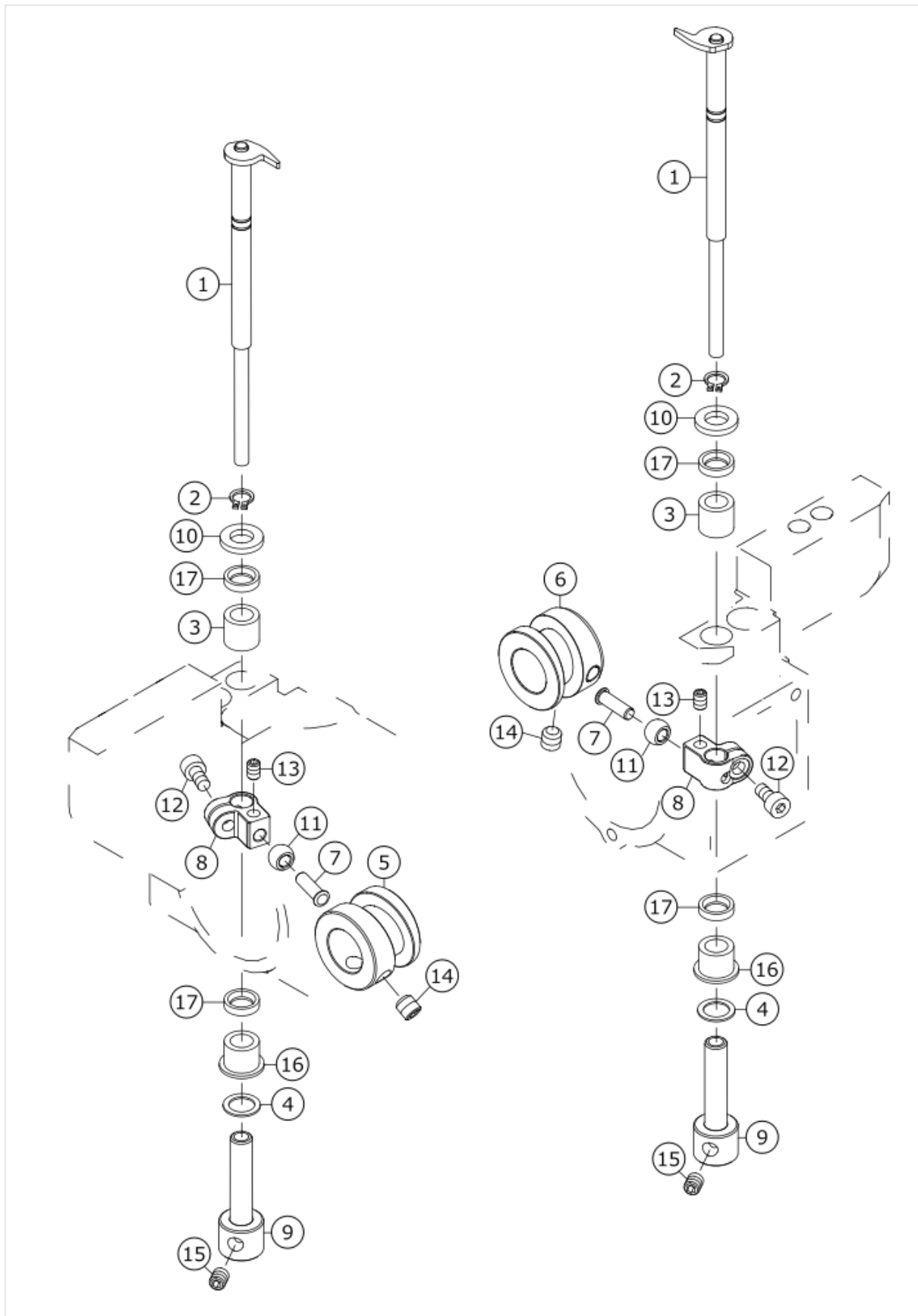

No.	品番	品吊	備考	子部品	消耗品	個数
1	40220184	OPENER_ASM_L				2.00
2	RC0650811KP	C-RING 7(6.5)				2.00
3	40227900	OPENER_METAL_UP				2.00
4	WP0820516SP	WASHER 11.6X8.2X0.6				2.00
5	40126547	OPENER_CAM_L				1.00
6	40126391	OPENER_CAM_R				1.00
7	40126360	OPENER_CAM_ROLLAR_SHAFT				2.00
8	40135475	OPENER_DRIVING_ARM				2.00
9	40229467	OPENER_SLEEVE				2.00
10	40227902	WASHER				4.00
11	40126351	OPENER_CAM_ROLLER				2.00
12	SM6040802TP	SCREW M4X0.7 L=8				2.00
13	SM8040612TP	SCREW M4 L=6				2.00
14	SM80606A2TP	SCREW M6 L=6				4.00
15	SM80606A2TP	SCREW M6 L=6				4.00
16	40227901	OPENER_METAL_DOWN				2.00
17	B1522552000	OIL SEAL RING				4.00

THREAD TRIMMER MECHANISM COMPONENTS (FOR LH-4588-7/LH-4578-7)

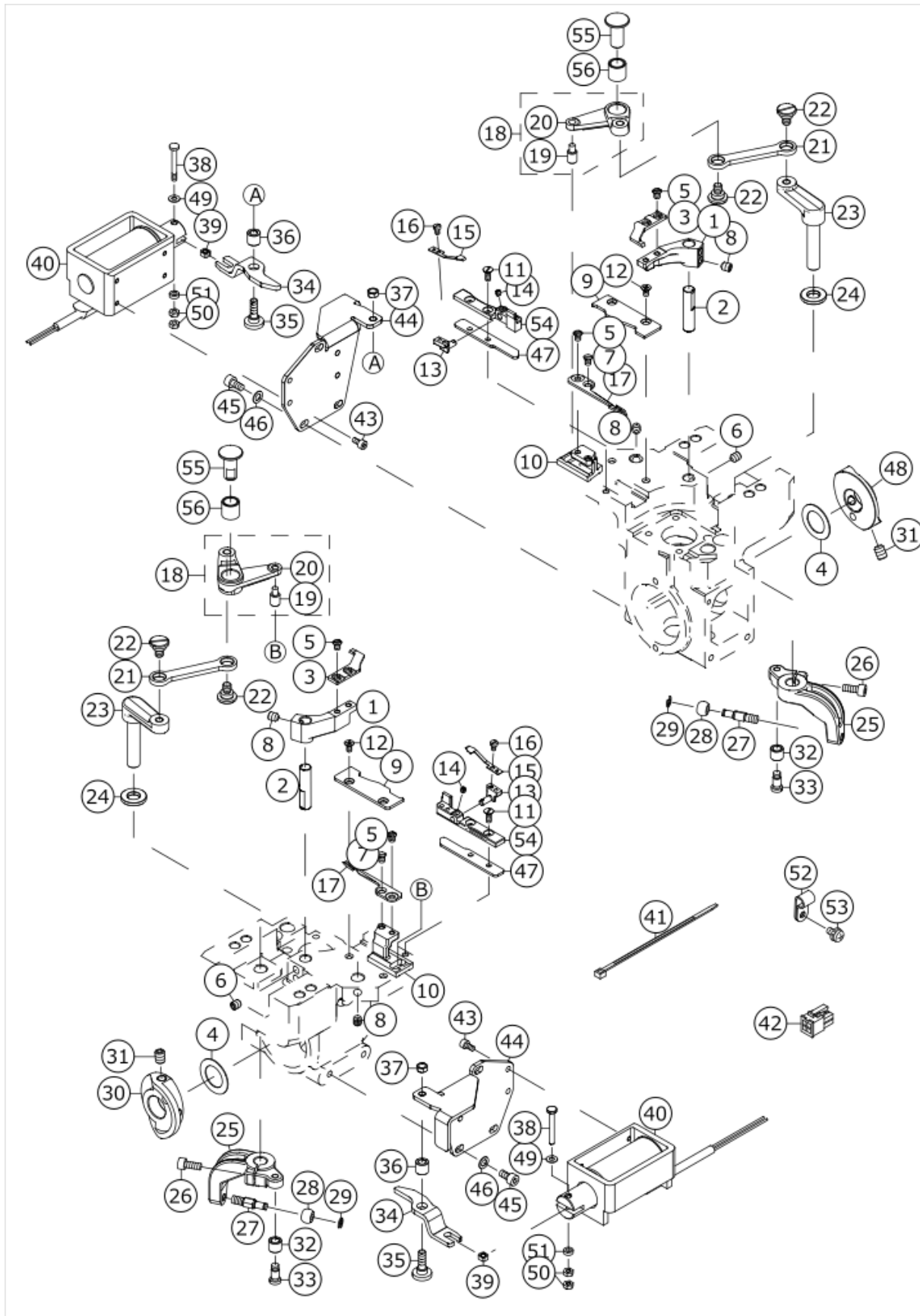

No.	品番	品名	備考	子部品	消耗品	個数
1	40220200	F_KNIFE_BASE				2.00
2	40198917	F_KNIFE_BASE_SHAFT				2.00
3	40235075	FIXED_KNIFE				2.00
4	D1231555B00	WASHER				2.00
5	SS6090580TP	SCREW 9/64-40 L=4.5				6.00
6	SM80506A2TP	SCREW M5 L=6				4.00
7	SS1090520TP	SCREW 9/64-40 L=5				2.00
8	SM80506A2TP	SCREW M5 L=6				6.00
9	40021883	D_KNIFE_BASE_GUIDE_R				2.00
10	40220262	DRIVING_KNIFE_BASE				2.00
11	SM1030800SM	SCREW M3X0.5 L=8				4.00
12	SM1030601SN	SCREW M3X0.5 L=6				4.00
13	40134967	CLAMP_SPRING_BASE				2.00
14	SM8030312TP	SCREW M3 L=3				2.00
15	40098764	CLAMP				2.00
16	SM6850400SP	SCREW M2.5 L=4				2.00
17	40098762	DRIVING_KNIFE				2.00
18	40220197	ASSY_KNIFE_DRIVING_ARM				2.00
19	40222681	KNIFE_BASE_SHAFT_PIN		*		1.00
20	40220196	M_KNIFE_DRIVING_ARM		*		1.00
21	40131635	CONNECTION_LINK				2.00
22	SD0800329TP	SHOULDER SCREW D=8 H=3.2				4.00
23	40220189	M_KNIFE_DRIVING_SHAFT				2.00
24	B185351200E	HOOK SHAFT WASHER				2.00
25	40256924	MOVING_KNIFE_DRIVING_ARM				2.00
26	SM6041002TP	SCREW M4X0.7 L=10				2.00
27	40256923	ROLLER_SHAFT				2.00
28	21470505	CAM ROLLER(245-7SP)				2.00
29	RE0300000K0	E-RING 3				2.00
30	40240569	TRIM_CAM_L				1.00
31	SM8060812TP	SCREW M6 L=8				4.00
32	13737804	DRIVING ARM BOSS ROLLER				2.00
33	SD0500726TP	SHOULDER SCREW D=5 H=7.2				2.00
34	40203599	KNIFE_DRIVING_ARM_LINK_2828				2.00
35	SD0650321TP	SHOULDER SCREW D=6.5 H=3.2				2.00
36	22956205	WIPER HINGE SCREW COLLAR				2.00
37	NS6110310SP	HEXAGONAL NUT 11/64-40				2.00
38	40203603	THREAD_TRIMMER_SOL_SHAFT				2.00
39	40203555	KNIFE_DRIVING_ARM_LINK_COLLAR				2.00
40	40192453	THREAD_TRIMMER_SOLENOID				2.00
41	EA9500B0100	CABLE BAND				5.00
42	HK034610040	CONNECTOR				1.00
43	SM6030602TP	SCREW M3X0.5 L=6				8.00
44	40203600	THREAD_TRIMMER_SOL_PLATE_2828				2.00
45	SM6040802TP	SCREW M4X0.7 L=8				6.00
46	WP0450000SD	WASHER 4.5X8X0.5				6.00
47	40220195	DRIVING_KNIFE_SUPPORT_SPACER				2.00
48	40242250	TRIM_CAM_R				1.00
49	WP0320501SD	WASHER				2.00
50	NM6030001SC	NUT M3X0.5 TYPE1				4.00

51	G5841830000	SPACER				2.00
52	HX00150000D	CABLE CLAMP				1.00
53	SL4040891SC	SCREW M4 L=8				1.00
54	40021899	D_KNIFE_SUPPORT_R				2.00
55	40135897	M_KNIFE_SUPPORT_PIN				2.00
56	SB30800140A	BEARING				2.00

LUBRICATION COMPONENTS

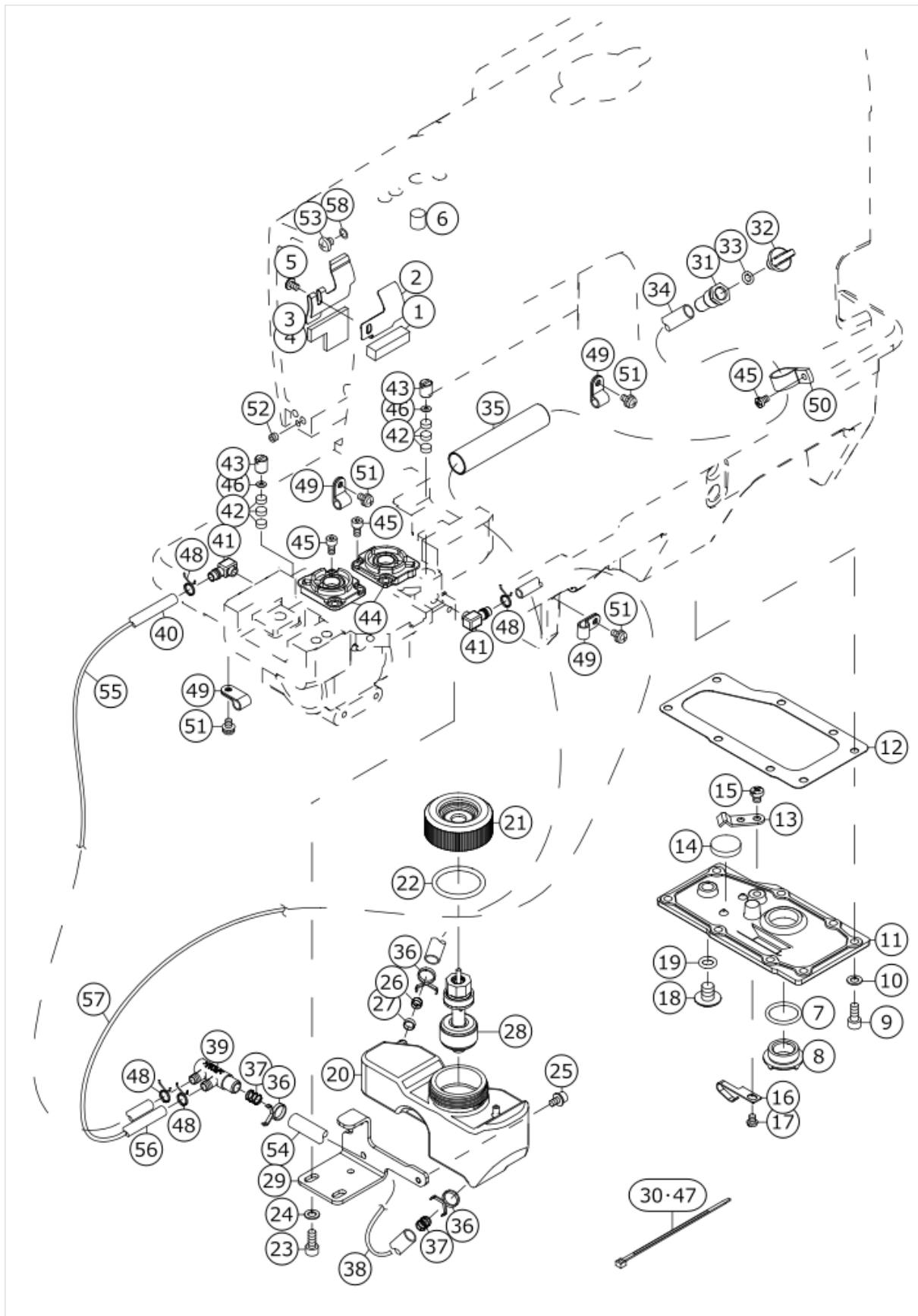

No.	品番	品名	備考	子部品	消耗品	個数
1	22603708	FELT				1.00
2	40039604	LUBRICATING_GUIDE				1.00
3	23204803	LUBRICATING GUIDE	WITH ONE NEEDLE			1.00
4	40039625	LUBRICATING_FELT	WITH ONE NEEDLE			1.00
5	SM6040650TP	SCREW				1.00
6	B3517009000	OIL FELT REAR				1.00
7	RO195240100	O-RING				1.00
8	40034246	OIL_SIGHT_WINDOW				1.00
9	SM6051202TP	SCREW M5X0.8 L=12				8.00
10	WP0550800SP	WASHER 5.5X10X0.8				8.00
11	40220154	BOX_COVER				1.00
12	40220155	BOX_COVER_PACKING				1.00
13	22944508	WIRE PRESSER A				1.00
14	B8228125000	OIL RESERVOIR MAGNET				1.00
15	SM4050655SP	SCREW M5 L=6				1.00
16	26230409	LUBRICATING OIL WICK STOPPER				1.00
17	SM40405C5SP	SCREW				1.00
18	SM0081001SD	SCREW				1.00
19	13170105	RUBBER RING				1.00
20	40221490	OIL_TANK				1.00
21	40221270	OIL_LEVEL_SWITCH_CAP				1.00
22	40221271	O-RING				1.00
23	SM6051202TP	SCREW M5X0.8 L=12				2.00
24	WP0550800SP	WASHER 5.5X10X0.8				2.00
25	SL6040892TN	SCREW M4 L=8				2.00
26	23630403	OIL FILTER				1.00
27	23630502	OIL FILTER STOPPER				1.00
28	40220156	FLOATER_SENSOR				1.00
29	40221497	OIL_TANK_BASE				1.00
30	EA9500B0100	CABLE BAND				1.00
31	40029075	LUBRICATING_INLET				1.00
32	40091195	LUBRICATING_INLET_CAP				1.00
33	RO048190100	O-RING				1.00
34	23630106	TUBE B				0.39
35	40220162	PIPE				1.00
36	23629405	PIPE STOPPER B				3.00
37	40038306	SPRING				2.00
38	CQ303000000	COTTON OIL WICK D=3				0.18
39	40220160	PIPE_JOINT				1.00
40	BT0700500EA	URETHANE TUBE CLEAR BLUE 7X5				0.38
41	40246998	OIL_JOINT				2.00
42	40220157	RUBBER_WASHER				6.00
43	40220158	OIL_ADJUSTING_SCREW				2.00
44	40220159	OIL_SUPPLY				2.00
45	SM6040802TP	SCREW M4X0.7 L=8				7.00
46	WP0280501SC	WASHER M2.6				2.00
47	EA9500B0100	CABLE BAND				4.00
48	40220161	PIPE_STOPPER				4.00

49	HX00150000D	CABLE CLAMP				4.00
50	HX00150000H	CABLE CLAMP				1.00
51	SL4040891SC	SCREW M4 L=8				4.00
52	SM8050402TP	SCREW				1.00
53	SM4050501SC	SCREW M5X0.8 L=5				1.00
54	23630106	TUBE B				0.07
55	CQ303000000	COTTON OIL WICK D=3				1.00
56	BT0700500EA	TUBE				0.24
57	CQ303000000	COTTON OIL WICK D=3				0.70
58	WP0510516SD	WASHER 5.1X7.5X0.5				1.00

THREAD NIPPER & SWITCH UNIT COMPONENTS

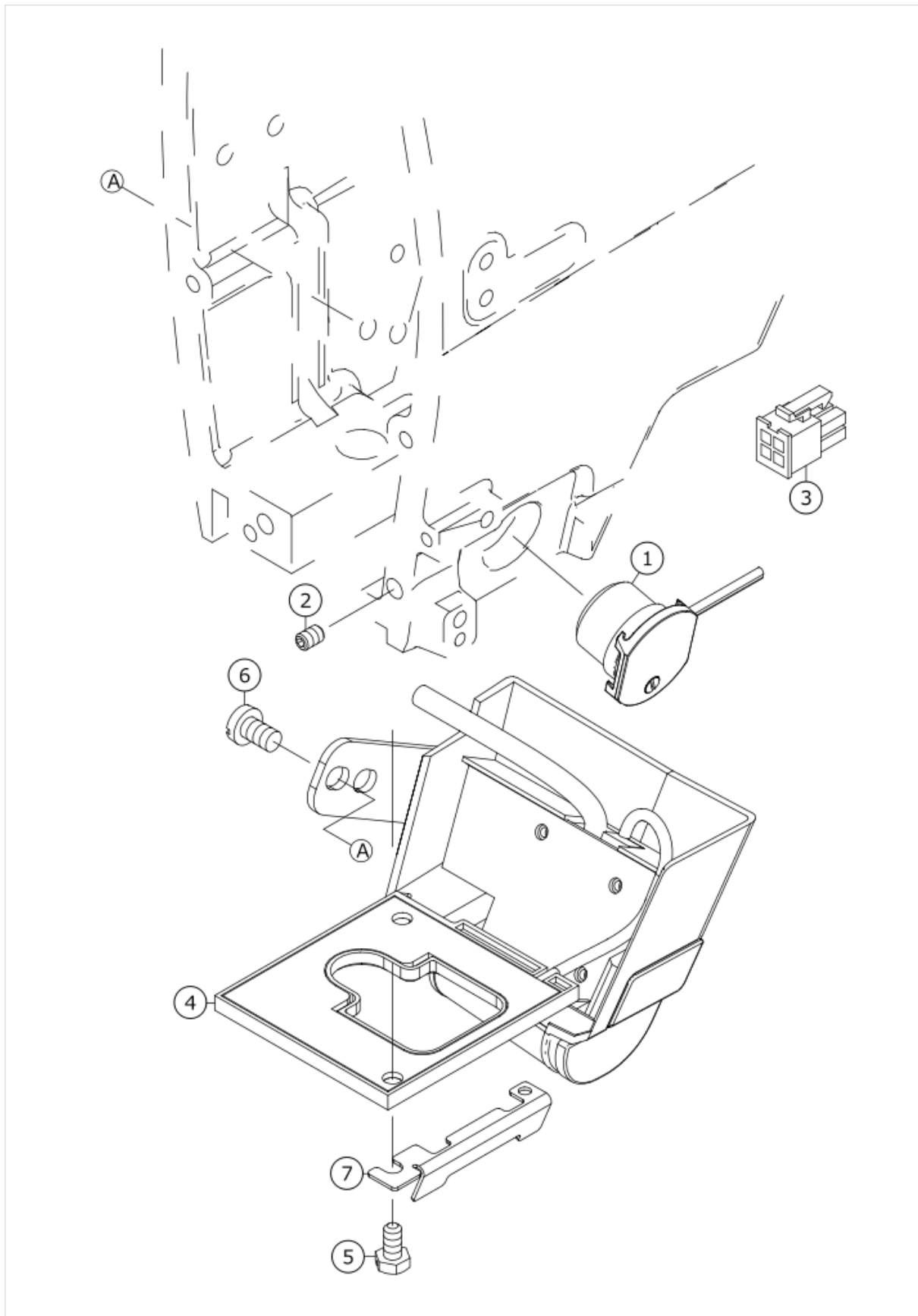

No.	品番	品名	備考	子部品	消耗品	個数
1	40220212	THREAD_NIPPER_SOLENOID	WITH THREAD TRIMMING			1.00
2	SM8040612TP	SCREW M4 L=6	WITH THREAD TRIMMING			1.00
3	HK034610040	CONNECTOR	WITH THREAD TRIMMING			1.00
4	40220077	LED_TB_SWITCH				1.00
5	SM9040800SP	SCREW				2.00
6	SM4050855SP	SCREW				2.00
7	40229885	SHADING_PLATE				1.00

BOBBIN WINDER COMPONENTS

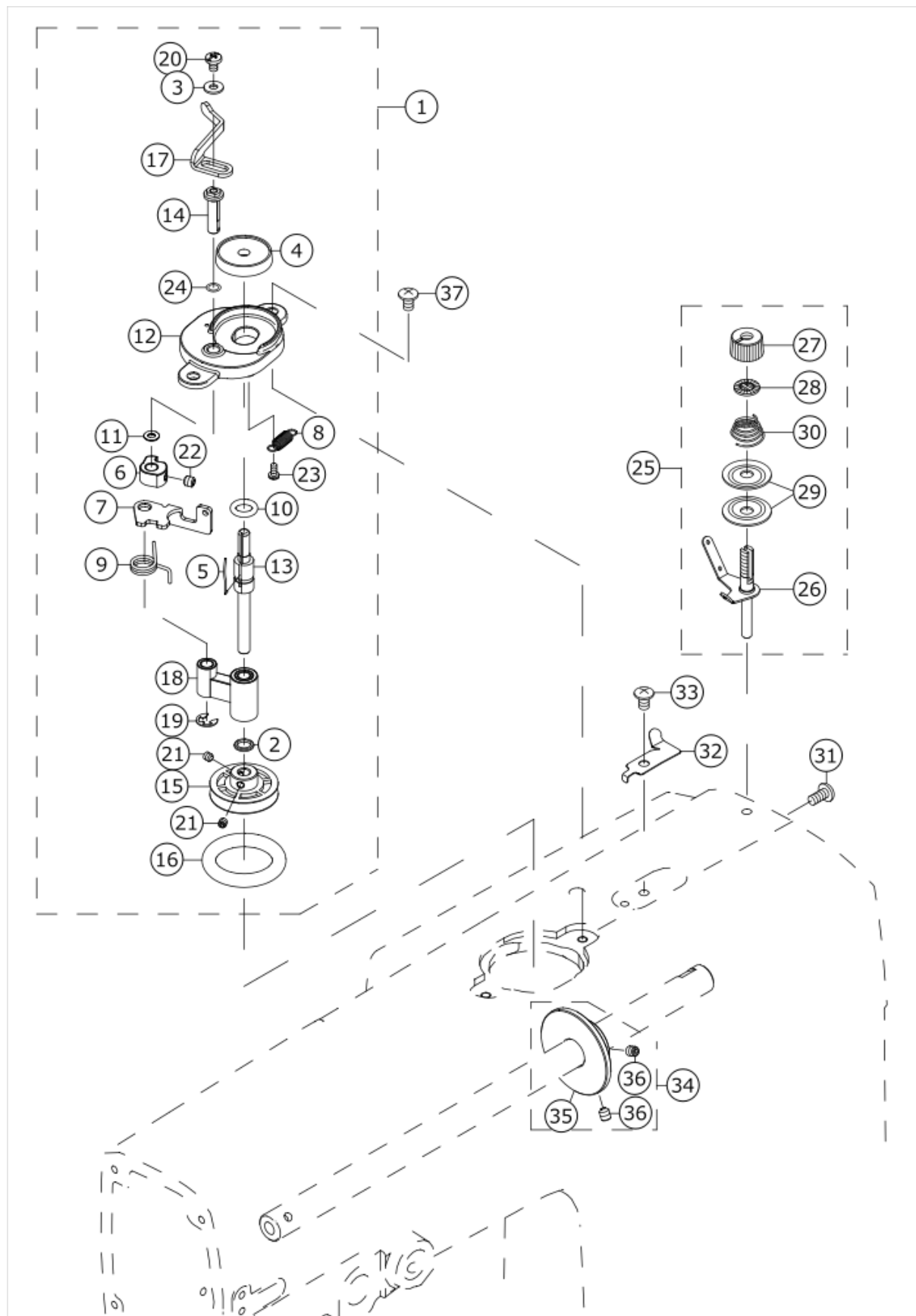

No.	品番	品吊	備考	子部品	消耗品	個数
1	40229428	BOBBIN_WINDER				1.00
2	22891204	BEARING_SUPPORT		*		1.00
3	40166870	WASHER		*		1.00
4	40166872	BOBBIN_SUPPORT		*		1.00
5	40166881	BOBBIN_FIXED_SPRING		*		1.00
6	40166885	BOBBIN_PRESSER_CAM		*		1.00
7	40166886	BOBBIN_WINDER_LEVER		*		1.00
8	40166887	BOBBIN_WINDER_LEVER_SPRING		*		1.00
9	40166888	SPRING		*		1.00
10	40166893	STOPPER_RUBBER		*		1.00
11	40166894	O_RING		*		1.00
12	40191108	BTW_BASE_N		*		1.00
13	40191109	BOBBIN_WINDER_SHAFT_N		*		1.00
14	40191111	BOBBIN_WINDER_ARM_SHAFT_N		*		1.00
15	40191113	BOBBIN_WINDER_WHEEL_N		*		1.00
16	40191114	BTW_WHEEL_RUBBER_N		*		1.00
17	40191115	BOBBIN_PRESSER_N		*		1.00
18	40191116	BOBBIN_WINDER_SUPPORT_N_ASM		*		1.00
19	RE0500000K0	E-RING		*		1.00
20	SM5040655SN	SCREW		*		1.00
21	SM8040412TP	SET SCREW M4 L=4		*		2.00
22	SM8050502TP	SCREW M5 L=5		*		1.00
23	ST4030651SN	SCREW M3 X 6		*		1.00
24	WP0651056SD	WASHER 6.5X11X1		*		1.00
25	40088958	BOBBIN_THREAD_TENSION_ASM.				1.00
26	40088959	BOBBIN_THREAD_TENSION_ROD_ASM.		*		1.00
27	22921308	THREAD_TENSION_NUT		*		1.00
28	22921407	ROTATION_STOPPER		*		1.00
29	22921506	THREAD_TENSION_DISK		*		2.00
30	22921704	THREAD_TENSION_SPRING		*		1.00
31	SM4051055SP	SCREW				1.00
32	40037008	THREAD_CUTTER				1.00
33	SM0050801SC	SCREW				1.00
34	40136292	BTW_DRIVING_WHEEL_ASM				1.00
35	40136293	BTW_DRIVING_WHEEL		*		1.00
36	SM80506A2TP	SCREW M5 L=6		*		2.00
37	SM0050801SC	SCREW				2.00

OPERATION PANEL COMPONENTS

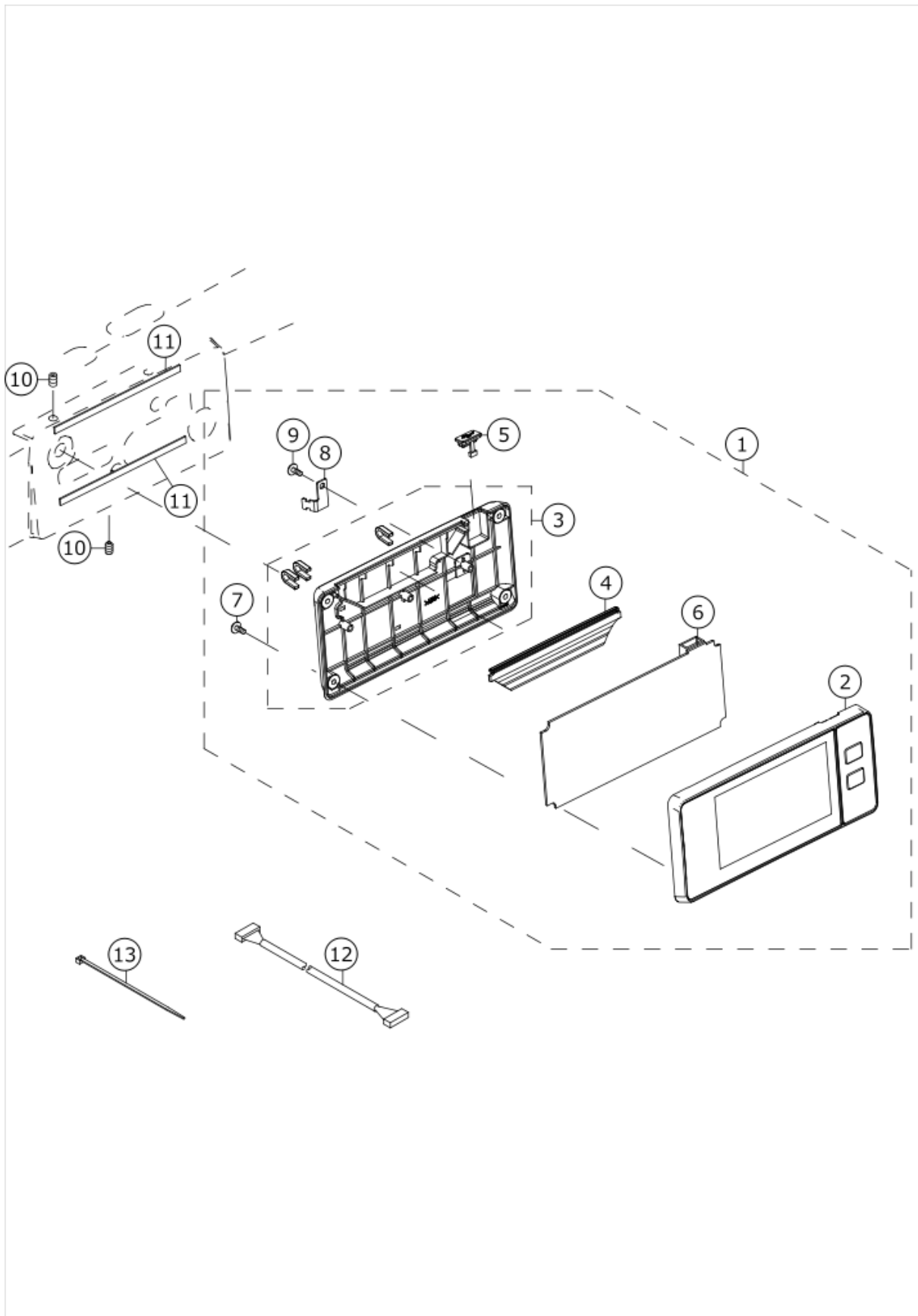

No.	品番	品名	備考	子部品	消耗品	個数
1	40223020	PANEL-F ASSY FOR LH4500C				1.00
2	40173451	PANEL_COVER_F ASSY		*		1.00
3	40173459	PANEL_COVER_R ASM		*		1.00
4	40172422	INDICATOR		*		1.00
5	40172423	USB_COVER		*		1.00
6	40169398	PNL-F PCB ASSY		*		1.00
7	SV4030802SN	TAPPING SCREW WITH FLANGE M3X8		*		4.00
8	40174580	PANEL_CABLE_CLAMP_PLATE		*		1.00
9	SV4030802SN	TAPPING SCREW WITH FLANGE M3X8		*		1.00
10	SM8050852TP	SCREW M5X8				3.00
11	40174408	PANEL_CUSHION_RUBBER				2.00
12	40175585	CTL-PNL CORD ASSY				1.00
13	EA9500B0100	CABLE BAND				1.00

THREAD STAND COMPONENTS

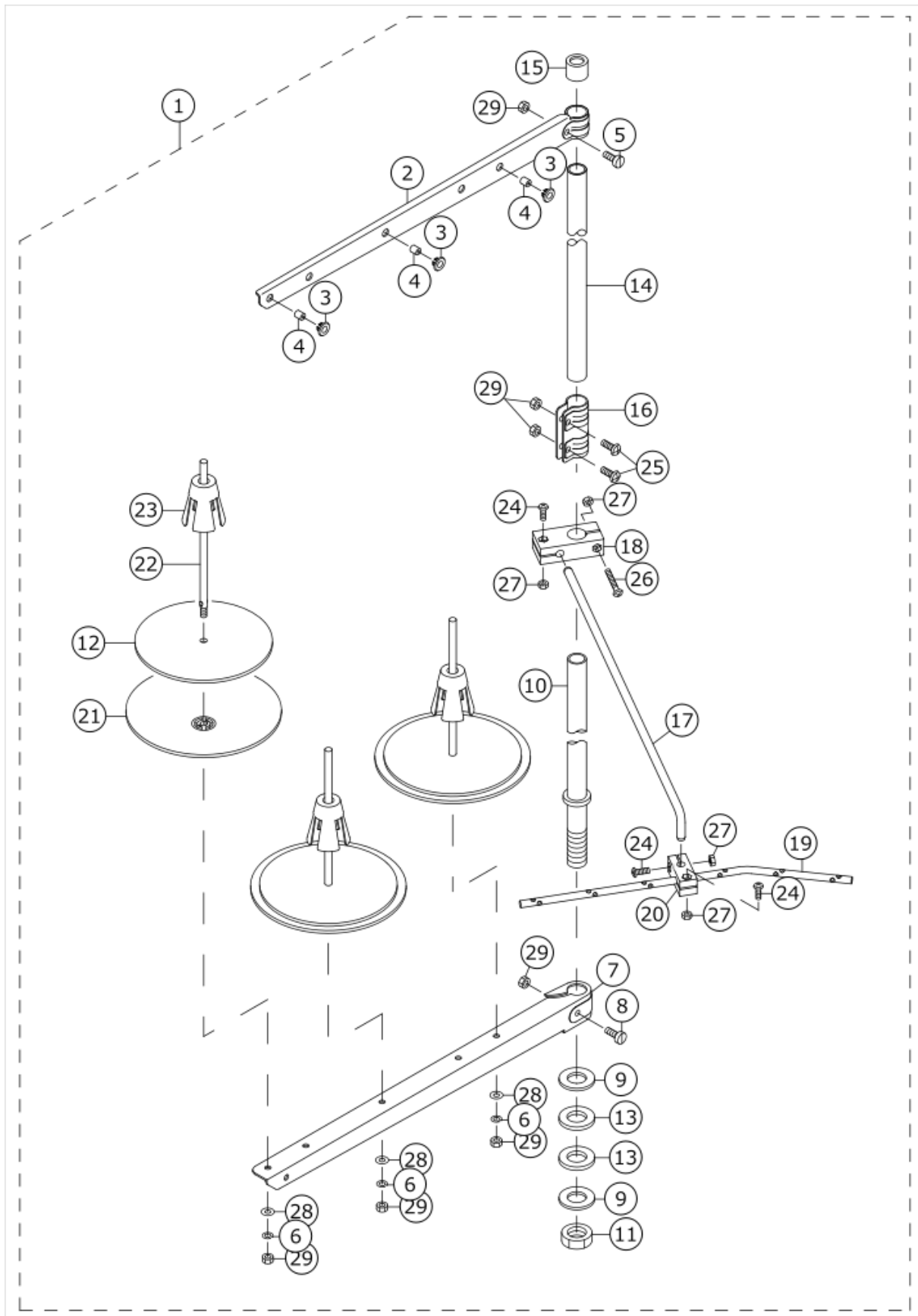

No.	品番	品吊	備考	子部品	消耗品	個数
1	40098387	THREAD_STAND_PACKING_DRAWING				1.00
2	40106575	SPOOL REST LONG ARM UPPER		*		1.00
3	40085795	THREAD GUIDE BUSHING		*		3.00
4	40085794	THREAD GUIDE		*		3.00
5	40096327	SPOOL REST ARM UPPER SCREW		*		1.00
6	WS0510002KN	SPRING WASHER M5		*		3.00
7	40106574	SPOOL REST LONG ARM LOWER		*		1.00
8	40096326	SPOOL REST ARM LOWER SCREW		*		1.00
9	WP1612616SE	WASHER 16X30X2.6		*		2.00
10	40085784	SPOOL REST ROD LOWER		*		1.00
11	40096325	SPOOL REST ROD NUT		*		1.00
12	40085789	SPOOL REST CUSHION		*		3.00
13	40085796	SPOOL REST ROD RUBBER CUSHION		*		2.00
14	40085785	SPOOL REST ROD UPPER		*		1.00
15	40085793	SPOOL REST ROD RUBBER CAP		*		1.00
16	40085792	SPOOL REST ROD JOINT		*		1.00
17	40106576	THREAD GUIDE ARM		*		1.00
18	40106579	THREAD GUIDE ARM BASE		*		1.00
19	40106583	THREAD GUIDE 6		*		1.00
20	40106580	THREAD GUIDE UNDER BASE		*		1.00
21	40085788	SPOOL REST		*		3.00
22	40085790	SPOOL PIN		*		3.00
23	40085791	SPOOL RETAINER		*		3.00
24	SM4041201SC	SCREW M4 L=12		*		3.00
25	SM4051405SE	SCREW M5 L=14		*		2.00
26	SM4042501SC	SCREW M4X0.7 L=25		*		1.00
27	NM6040002SC	NUT M4		*		4.00
28	WP0531001SC	WASHER M5		*		3.00
29	NM6050001SE	NUT M5		*		7.00

ACCESSORIE PARTS COMPONENTS

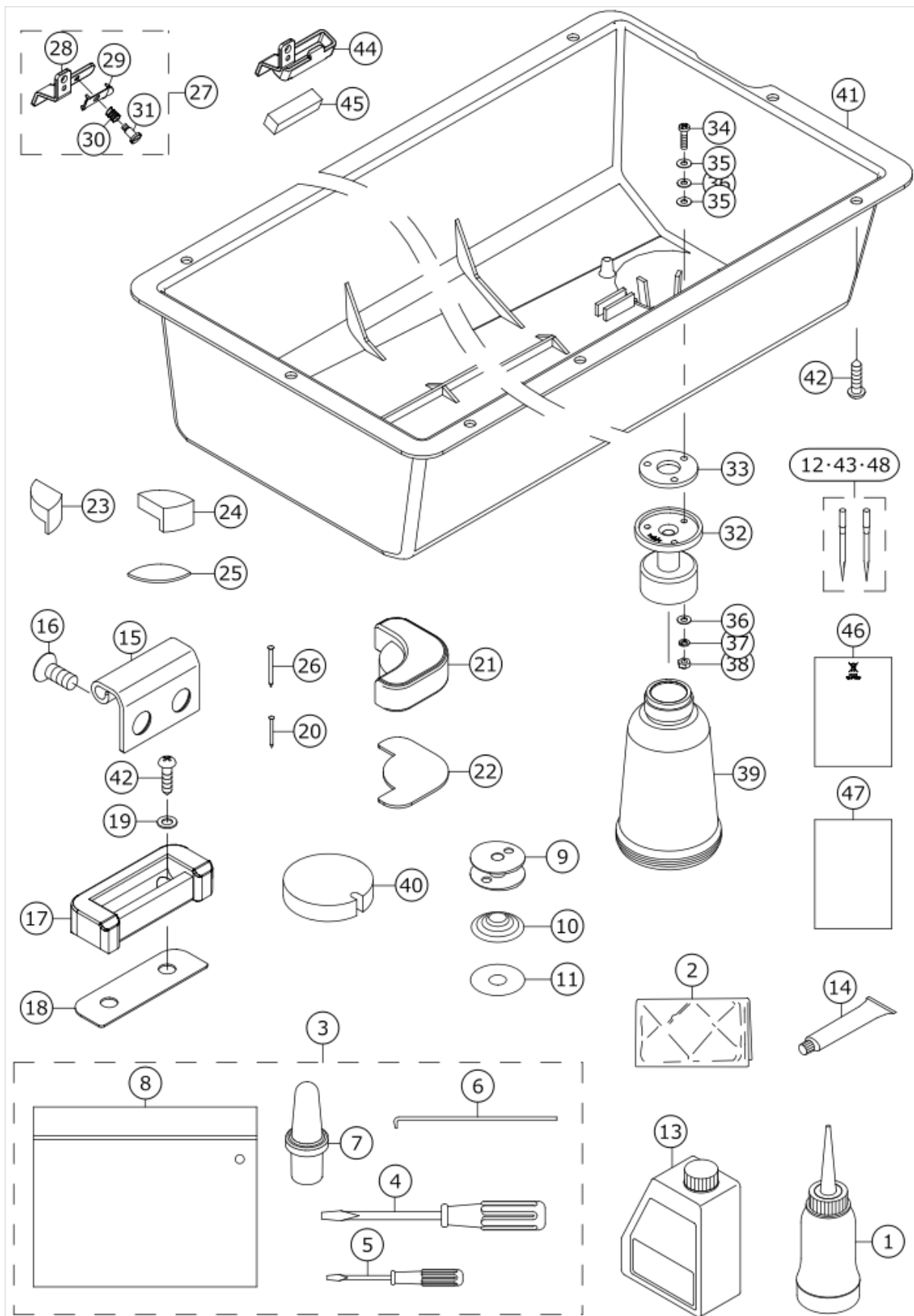

No.	品番	品名	備考	子部品	消耗品	個数
1	B91210120A0	OILER ASM.				1.00
2	22933303	HEAD COVER				1.00
3	40220218	ACCESSORIE_BAG_ASM				1.00
4	22933105	SCREW DRIVER		*		1.00
5	22933204	SCREW DRIVER		*		1.00
6	B9101490000	DRIVER		*		1.00
7	40174570	HEAD_SUPPORT_ROD		*		1.00
8	22932800	ACCESSORIE BAG		*		1.00
9	40235203	BOBBIN				2.00
10	40055358	SPRING_L	TYPE G			2.00
11	22819809	SHEET	TYPE G			2.00
12	MDP500B2102	NEEDLE DPX5 #21-2	TYPE G			1.00
13	40102087	JUKI CORPORATION GENUINE OIL 7				1.00
14	40006323	JUKI GREASE A TUBE				1.00
15	40125869	HINGE				2.00
16	B1516210D00	SCREW				4.00
17	40232783	HINGE_RUBBER				2.00
18	40163914	HINGE_SPACER				2.00
19	WP0550800SP	WASHER 5.5X10X0.8				4.00
20	22926208	NAIL				2.00
21	40232782	CUSHION_RUBBER				2.00
22	10740900	RUBBER				8.00
23	40232784	CUSHION_RUBBER_LEFT				1.00
24	40232785	CUSHION_RUBBER_RIGHT				1.00
25	40151805	RUBBER_CUSHION_SHEET				4.00
26	10539906	SET NAIL				6.00
27	40220216	THREAD_GUIDE_ASM	TYPE G			1.00
28	40220217	THREAD_GUIDE		*		1.00
29	40042716	THREAD_PRESSER_PLATE		*		1.00
30	B1132521000	THREAD PRESSER PLATE SPRING		*		1.00
31	14044903	SCREW		*		1.00
32	40220258	OIL_POT_JOINT				1.00
33	40220257	OIL_SEAL				1.00
34	SM4031201SC	SCREW M3X0.5 L=12				3.00
35	10748101	OIL REMOVING SETSCREW PACKING				6.00
36	WP0320501SC	WASHER M3				6.00
37	WS0310002KN	SPRING WASHER M3				3.00
38	NM6030001SC	NUT M3X0.5 TYPE1				3.00
39	B9121012000	OIL CAN				1.00
40	40126405	OIL_FILTER				1.00
41	40220256	OIL_PAN				1.00
42	SK3482001SE	WOOD SCREW D=4.8 L=20				14.00
43	MDP500B1102	NEEDLE DPX5 #11-2	TYPE F			1.00
44	40220215	THREAD_GUIDE_FELT	TYPE F AND TYPE S			1.00
45	22603708	FELT	TYPE F AND TYPE S			1.00
46	CM600100201	WEEE INFORMATION SHEET	FOR JCE			1.00
47	40220220	DECLARATION OF INCORPORATION	FOR JCE			1.00
48	MDP500B1402	NEEDLE DPX5#14-2	TYPE S			1.00

ELECTRICAL COMPONENTS (SC-956B)

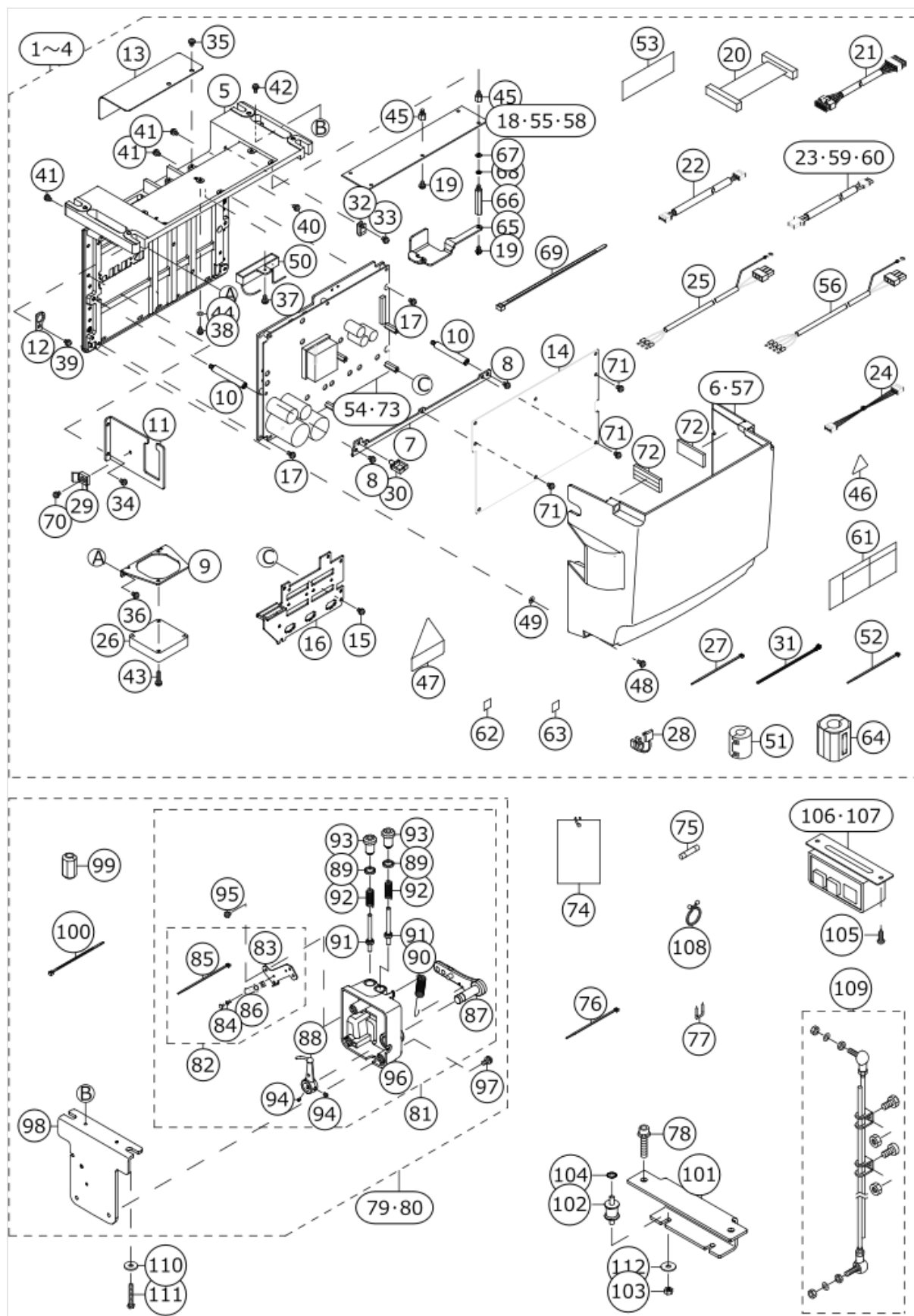









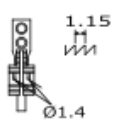
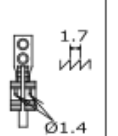

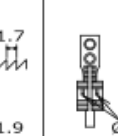
No.	品番	品名	備考	子部品	消耗品	個数
1	40212486	PSC UNIT 1PHASE 220-240V	FOR 1PHASE 220 -240V,220-240V CN			1.00
2	40212487	PSC UNIT 3PHASE 200-240V	FOR 3PHASE 200-240V			1.00
3	40212488	PSC UNIT 1PHASE 100-120V	FOR 1PHASE 100-120 JA			1.00
4	40212489	PSC UNIT 1PHASE 220-240V CE	FOR 1PHASE 220-240V CE			1.00
5	40212704	BOX_FRAME		*		1.00
6	40171747	BOX COVER		*		1.00
7	40115877	MAIN_PLATE		*		1.00
8	SL4040881SC	SCREW M4 L=8		*		2.00
9	40115874	FAN_PLATE		*		1.00
10	40143990	STUD		*		2.00
11	40171750	PLATE_B		*		1.00
12	40173469	PLATE_C		*		1.00
13	40115879	FAN_COVER		*		1.00
14	40222920	CTL PCB ASSY		*		1.00
15	SL4040881SC	SCREW M4 L=8		*		4.00
16	40208464	SUB-D HEAT SINK		*		1.00
17	SL4041081SC	SCREW M4 L=10		*		4.00
18	40186895	FLT-G PCB ASSY	FOR 1PHASE 220 -240V,220-240V CN	*		1.00
19	SL4040881SC	SCREW M4 L=8		*		5.00
20	40170983	CTL-PWR S CORD ASSY		*		1.00
21	40175579	CTL-PWR P CORD ASSY		*		1.00
22	40175580	CTL-PWR T CORD ASSY		*		1.00
23	40175581	FLT-PWR CORD ASSY (200V)	FOR 1PHASE 220 -240V CN,3PHAS E 200-240V	*		1.00
24	40175583	FLT-CTL CORD ASSY		*		1.00
25	40175586	AC INPUT CORD S ASSY	FOR 1PHASE 220-240V	*		1.00
26	40111214	FAN MOTOR ASSY		*		1.00
27	EA9500B0100	CABLE BAND		*		1.00
28	KX000000320	BUSH		*		1.00
29	KX000000260	SADDLE TYPE TIE MOUNT		*		1.00
30	HX00222000D	WIRE SADDLE		*		1.00
31	HX00292000A	CABLE BAND		*		1.00
32	HX00150000A	CABLE CLAMP		*		1.00
33	SL4040881SC	SCREW M4 L=8		*		1.00
34	SL4040881SC	SCREW M4 L=8		*		2.00
35	SL4040881SC	SCREW M4 L=8		*		2.00
36	SL4040881SC	SCREW M4 L=8		*		2.00
37	SL4040881SC	SCREW M4 L=8		*		1.00
38	SL4040881SC	SCREW M4 L=8		*		1.00
39	SL4040881SC	SCREW M4 L=8		*		1.00
40	SL4040881SC	SCREW M4 L=8		*		10.00

41	SL4040881SC	SCREW M4 L=8		*		3.00
42	SL4041081SC	SCREW M4 L=10		*		1.00
43	SL4042091SC	SCREW M4 L=20		*		2.00
44	WP0430800SC	WASHER M4		*		1.00
45	HX00339000M	SPACER		*		5.00
46	CM300100001	VOLTAGE WARNING LABEL (31.5)		*		1.00
47	CM300400602	VOLTAGE CAUTION LABEL L=25	FOR 1PHASE 220-240V	*		1.00
48	SL4041281SC	SCREW M4 L=12		*		4.00
49	M8002430000	STOPPER		*		4.00
50	40141206	RESISTANCE_A_ASSY		*		1.00
51	KN000000070	CORES		*		1.00
52	EA9500B0100	CABLE BAND		*		1.00
53	40114398	MAIN COOL SHEET		*		2.00
54	40206950	PWR PCB ASSY	EXCEPT CE	*		1.00
55	40219340	FLT-T PCB ASSY	FOR 3PHASE 200 -240V,1PHASE 1 00-120 JA	*		1.00
56	40175587	AC INPUT CORD T ASSY	FOR 3PHASE 200 -240V,1PHASE 1 00-120 JA	*		1.00
57	40170984	BOX_COVER_CE	FOR 1PHASE 220-240V CE	*		1.00
58	40169130	FLT-S PCB ASSY	FOR 1PHASE 220-240V CE	*		1.00
59	40175582	FLT-PWR CORD ASSY (100V)	FOR 1PHASE 100-120 JA	*		1.00
60	40219664	FLT-PWR CORD ASSY (CE)	FOR 1PHASE 220-240V CE	*		1.00
61	CM300100402	VOLTAGE DANGER LABEL 3 (SMALL)	FOR 3PHASE 200 -240V,1PHASE 1 00-120 JA	*		1.00
62	CM600100101	WEEE MARK LABEL S	FOR 1PHASE 220-240V CE	*		1.00
63	40150131	EAC_MARK_LABEL_S	FOR 1PHASE 220-240V CE	*		1.00
64	HN004210000	CORES	FOR 1PHASE 220-240V CE	*		1.00
65	40219663	CORE_MOUNTING_BRACKET	FOR 1PHASE 220-240V CE	*		1.00
66	HX00339000D	SPACER	FOR 1PHASE 220-240V CE	*		2.00
67	WP0430800SC	WASHER M4	FOR 1PHASE 220-240V CE	*		2.00
68	WS0410002KN	SPRING WASHER M4	FOR 1PHASE 220-240V CE	*		2.00
69	HX00065000B	CABLE BAND	FOR 1PHASE 220-240V CE	*		1.00
70	SL4040881SC	SCREW M4 L=8		*		1.00
71	SL4040881SC	SCREW M4 L=8		*		8.00
72	40212110	GASKET	TYPE CE	*		1.00

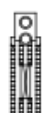
73	40212480	PWR CE PCB ASSY	TYPE CE	*		1.00
74	M300451100A	VOLTAGE INDICATION CARD				1.00
75	HF0013050P0	SLO-BLO FUSE				1.00
76	EA9500B0200	CABLE BAND				2.00
77	MAO11532000	CORD STAPLE				2.00
78	SL6084092TN	SCREW M8 L=40				4.00
79	40192537	PEDAL SENSOR BASE SP ASSY	EXCEPT CE			1.00
80	40192573	PEDAL SENSOR BASE SP ASSY	TYPE CE			1.00
81	40192574	PEDAL SENSOR SP ASSY		*		1.00
82	40192575	PEDAL SENSOR COIL HOLD ASSY		*		1.00
83	40042136	COIL_BASE		*		1.00
84	40052809	NYLON_RIVET		*		2.00
85	EA9500B0100	CABLE BAND		*		1.00
86	40192576	PEDAL SENSOR COIL ASSY		*		1.00
87	40042131	PEDAL_LEVER		*		1.00
88	40177068	PEDAL_LEVER_FG		*		1.00
89	40006202	ADJUST_NUT		*		2.00
90	40006207	FRONT_SPRING		*		1.00
91	40006208	SPRING_SHAFT_A		*		2.00
92	40049426	SPRING_C		*		2.00
93	40006212	ADJUST_SCREW		*		2.00
94	SM8040612TP	SCREW M4 L=6		*		2.00
95	SV4030601SR	SCREW M3 L=6		*		2.00
96	40170980	PEDAL_SENSOR_BASE		*		1.00
97	SL4051281SC	SCREW M5 L=12		*		3.00
98	40170964	PEDAL SENSOR BRACKET		*		1.00
99	HN002840000	CORES	FOR 1PHASE 220-240V CE	*		1.00
100	EA9500B0100	CABLE BAND	FOR 1PHASE 220-240V CE	*		2.00
101	40194296	RUBBER_CUSHION_BRKT				2.00
102	40165702	RUBBER_CUSHION				4.00
103	NM6060001SC	NUT M6X1 TYPE1				4.00
104	WT0640001KN	TOOTH WASHER				4.00
105	SK3512001SE	WOOD SCREW D=5.1 L=20	FOR 1PHASE 220 -240V,220-240V CN			2.00
106	40111651	POWER SWITCH ASM	FOR 1PHASE 220 -240V,220-240V CN			1.00
107	40118323	POWER SWITCH ASSY	FOR 1PHASE 220 -240V,220-240V CN			1.00
108	HX005100000	OMEGALOCK				2.00
109	40088314	CONNECING_ROD_ASSY				1.00
110	WP0612056SD	WASHER 6.1X18.5X2				2.00
111	ST9053511SR	TAPPING SCREW M5X35				2.00
112	WP0651646SC	WASHER				4.00

TABLE OF EXCHANGING GAUGE PARTS (FOR LH-4578C)(1)

Needle gauge size 針 幅		Feed Dog 送り歯											
Code コード													
	inch	mm	No	Part No.	No	Part No.	No	Part No.	No	Part No.	No	Part No.	
B	1/8	3.2	①	402-32780	⑦	402-32781	⑬	402-43739	-	-	-	-	
C	5/32	4.0	-	-	-	-	⑭	402-43740	⑳	402-43741	④③	402-43742	
D	3/16	4.8	②	400-35884	⑧	400-33564	⑮	400-33718	㉑	226-30404	④④	400-25785	
E	7/32	5.6	③	400-35885	⑨	400-33565	-	-	㉒	226-30503	④⑤	400-25786	
F	1/4	6.4	④	400-35886	⑩	400-33566	⑯	400-33720	㉓	226-30602	④⑥	400-25787	
G	9/32	7.1	⑤	400-35887	⑪	400-33567	⑰	400-33722	㉔	226-30800	④⑦	400-25788	
H	5/16	7.9	⑥	400-35888	⑫	400-33568	⑱	400-33723	㉕	226-30909	④⑧	400-25789	
K	3/8	9.5	-	-	-	-	⑲	400-33724	㉖	226-31006	④⑨	400-25790	
W	7/16	11.1	-	-	-	-	-	-	㉗	226-31105	⑤⑩	400-25791	
L	1/2	12.7	-	-	-	-	⑳	400-33727	㉘	226-31303	⑤①	400-25792	
M	5/8	15.9	-	-	-	-	-	-	㉙	226-31402	⑤②	400-25793	
N	3/4	19.1	-	-	-	-	㉑	400-33729	㉚	226-31501	⑤③	400-25794	
P	7/8	22.2	-	-	-	-	㉒	400-33731	㉛	226-31709	⑤④	400-25795	
Q	1	25.4	-	-	-	-	㉓	400-33732	㉜	226-31808	⑤⑤	400-25796	
R	1-1/8	28.6	-	-	-	-	㉔	400-33733	㉝	226-31907	⑤⑥	400-25797	
S	1-1/4	31.8	-	-	-	-	㉕	400-33734	㉞	226-32004	⑤⑦	400-25798	
T	1-3/8	34.9	-	-	-	-	-	-	㉟	226-32103	⑤⑧	400-25799	
U	1-1/2	38.1	-	-	-	-	-	-	㊱	226-32202	⑤⑨	400-25800	
Stitch spec. 縫仕様	A	★											
	F	★		★		★		★		★		★	
	S	★											
	下送り	★											



Needle gauge size 針 幅		Feed dog(Lower feed) 送り歯(下送り)				Needle clamp asm. 針留組		Sliding plate asm. 滑り板組		Sliding plate asm. (Front) 滑り板(前)組					
Code コード															
	inch	mm	No	Part No.	No	Part No.	No	Part No.	No	Part No.	No	Part No.	No	Part No.	
B	1/8	3.2	⑥①	402-42613	-	-	⑥⑦	101-47650	-	-	-	-	-	-	
C	5/32	4.0	-	-	-	-	⑥⑧	101-47759	-	-	-	-	-	-	
D	3/16	4.8	⑥②	402-42614	-	-	⑥⑨	101-47858	-	-	-	-	-	-	
E	7/32	5.6	-	-	-	-	⑦①	101-47957	-	-	-	-	-	-	
F	1/4	6.4	⑥③	232-05503	-	-	⑦②	101-48054	⑧⑤	402-20206	-	-	-	-	
G	9/32	7.1	-	-	-	-	⑦③	101-48153	-	-	-	-	-	-	
H	5/16	7.9	-	-	-	-	⑦④	101-48252	-	-	-	-	-	-	
K	3/8	9.5	-	-	-	-	⑦⑤	101-48351	-	-	-	-	-	-	
W	7/16	11.1	-	-	-	-	⑦⑥	101-48450	-	-	-	-	-	-	
L	1/2	12.7	-	-	⑥④	400-62249	⑦⑦	101-48559	-	-	⑧⑨	400-42874	⑨①	232-06709	
M	5/8	15.9	-	-	-	-	⑦⑧	101-48658	⑧⑥	402-22670	-	-	-	-	
N	3/4	19.1	-	-	⑥⑤	400-62251	⑦⑨	101-48757	-	-	-	-	-	-	
P	7/8	22.2	-	-	⑥⑥	400-62252	⑧①	101-48856	-	-	-	-	-	-	
Q	1	25.4	-	-	⑥⑦	400-62253	⑧②	101-48955	⑧⑦	402-22671	-	-	-	-	
R	1-1/8	28.6	-	-	-	-	⑧③	101-49052	-	-	-	-	-	-	
S	1-1/4	31.8	-	-	-	-	⑧④	101-49151	-	-	-	-	-	-	
T	1-3/8	34.9	-	-	-	-	⑧⑤	101-49250	⑧⑧	402-22672	-	-	-	-	
U	1-1/2	38.1	-	-	-	-	⑧⑥	101-49359	-	-	-	-	-	-	
Stitch spec. 縫仕様	A	★													
	F	★		★		★		★		★		★		★	
	S	★													
	下送り	★		★		★		★		★		★		★	

No.	品番	品吊	備考	子部品	消耗品	個数
1	40232780	FEED_DOG_F_1_8_OP				1.00
2	40035884	FEED_DOG_TYPE_F_3/16				1.00
3	40035885	FEED_DOG_TYPE_F_7/32				1.00
4	40035886	FEED_DOG_TYPE_F_1/4				1.00
5	40035887	FEED_DOG_TYPE_F_9/32				1.00
6	40035888	FEED_DOG_TYPE_F_5/16				1.00
7	40232781	FEED_DOG_F_1_8				1.00
8	40033564	FEED_DOG_TYPE_F_3/16				1.00
9	40033565	FEED_DOG_TYPE_F_7/32				1.00
10	40033566	FEED_DOG_TYPE_F_1/4				1.00
11	40033567	FEED_DOG_TYPE_F_9/32				1.00
12	40033568	FEED_DOG_TYPE_F_5/16				1.00
13	40243739	FEED_DOG_AA_1/8				1.00
14	40243740	FEED_DOG_AA_5/32				1.00
15	40033718	FEED_DOG_TYPE_AA_3/16				1.00
16	40033720	FEED_DOG_TYPE_AA_1/4				1.00
17	40033722	FEED_DOG_TYPE_AA_9/32				1.00
18	40033723	FEED_DOG_TYPE_AA_5/16				1.00
19	40033724	FEED_DOG_TYPE_AA_3/8				1.00
20	40033727	FEED_DOG_TYPE_AA_1/2				1.00
21	40033729	FEED_DOG_TYPE_AA_3/4				1.00
22	40033731	FEED_DOG_TYPE_AA_7/8				1.00
23	40033732	FEED_DOG_TYPE_AA_1				1.00
24	40033733	FEED_DOG_TYPE_AA_1_1/8				1.00
25	40033734	FEED_DOG_TYPE_AA_1_1/4				1.00
26	40243741	FEED_DOG_S_5/32				1.00
27	22630404	FEED DOG 3/16 (4.8MM)				1.00
28	22630503	FEED DOG 7/32 (5.6MM)				1.00
29	22630602	FEED DOG 1/4				1.00
30	22630800	FEED DOG 9/32 (7.1MM)				1.00
31	22630909	FEED DOG 5/16 (7.9MM)				1.00
32	22631006	FEED DOG 3/8 (9.5MM)				1.00
33	22631105	FEED DOG 7/16 (11.1MM)				1.00
34	22631303	FEED DOG 1/2 (12.7MM)				1.00
35	22631402	FEED DOG 5/8 (15.9MM)				1.00
36	22631501	FEED DOG 3/4 (19.1MM)				1.00
37	22631709	FEED DOG 7/8 (2.2MM)				1.00
38	22631808	FEED DOG 1 (25.4MM)				1.00
39	22631907	FEED DOG 1.1/8 (28.6MM)				1.00
40	22632004	FEED DOG 1.1/4 (31.4MM)				1.00
41	22632103	FEED DOG 1.3/8 (34.9MM)				1.00
42	22632202	FEED DOG 1.1/2 (38.1MM)				1.00
43	40243742	FEED_DOG_S_5/32				1.00
44	40025785	FEED_DOG_TYPE_SA_3/16				1.00
45	40025786	FEED_DOG_TYPE_SA_7/32				1.00
46	40025787	FEED_DOG_TYPE_SA_1/4				1.00
47	40025788	FEED_DOG_TYPE_SA_9/32				1.00
48	40025789	FEED_DOG_TYPE_SA_5/16				1.00
49	40025790	FEED_DOG_TYPE_SA_3/8				1.00
50	40025791	FEED_DOG_TYPE_SA_7/16				1.00

51	40025792	FEED_DOG_TYPE_SA_1/2				1.00
52	40025793	FEED_DOG_TYPE_SA_5/8				1.00
53	40025794	FEED_DOG_TYPE_SA_3/4				1.00
54	40025795	FEED_DOG_TYPE_SA_7/8				1.00
55	40025796	FEED_DOG_TYPE_SA_1				1.00
56	40025797	FEED_DOG_TYPE_SA_1-1/8				1.00
57	40025798	FEED_DOG_TYPE_SA_1-1/4				1.00
58	40025799	FEED_DOG_TYPE_SA_1-3/8				1.00
59	40025800	FEED_DOG_TYPE_SA_1-1/2				1.00
60	40242613	FEED_DOG_1/8				1.00
61	40242614	FEED_DOG_3/16				1.00
62	23205503	FEED DOG 1/4				1.00
63	40062249	FEED_DOG_1/2				1.00
64	40062251	FEED_DOG_3/4				1.00
65	40062252	FEED_DOG_7/8				1.00
66	40062253	FEED_DOG_1				1.00
67	10147650	NEEDLE CLAMP ASM. 1/8				1.00
68	10147759	NEEDLE CLAMP ASM. 5/32				1.00
69	10147858	NEEDLE CLAMP ASM. 3/16				1.00
70	10147957	NEEDLE CLAMP ASM. 7/32				1.00
71	10148054	NEEDLE CLAMP ASM. 1/4				1.00
72	10148153	NEEDLE CLAMP ASM. 9/32				1.00
73	10148252	NEEDLE CLAMP ASM. 5/16				1.00
74	10148351	NEEDLE CLAMP ASM. 3/8				1.00
75	10148450	NEEDLE CLAMP ASM. 7/16				1.00
76	10148559	NEEDLE CLAMP ASM. 1/2				1.00
77	10148658	NEEDLE CLAMP ASM. 5/8				1.00
78	10148757	NEEDLE CLAMP ASM. 3/4				1.00
79	10148856	NEEDLE CLAMP ASM. 7/8				1.00
80	10148955	NEEDLE CLAMP ASM. 1				1.00
81	10149052	NEEDLE CLAMP ASM. 1-1/8				1.00
82	10149151	NEEDLE CLAMP ASM. 1-1/4				1.00
83	10149250	NEEDLE CLAMP ASM. 1-3/8				1.00
84	10149359	NEEDLE CLAMP ASM. 1-1/2				1.00
85	40220206	ASSY_SLIDE_PLANTE-A				1.00
86	40222670	ASSY_SLIDE_PLATE-B				1.00
87	40222671	ASSY_SLIDE_PLATE-C				1.00
88	40222672	ASSY_SLIDE_PLATE-D				1.00
89	40042874	ASSY_SLIDE_PLATE_F_STANDARD				1.00
90	23206709	BED SLIDE (FRONT)A				1.00

TABLE OF EXCHANGING GAUGE PARTS (FOR LH-4578C)(2)





Needle gauge size 針 幅			Presser foot asm. 押え (組)								Swivel guide Presser asm. スィブルガイド押え (組)	
Code コード			Tip-divided 移動式先割れ		Lower feed 下送り		Lower feed 下送り		Lower feed 下送り		Swivel guide Presser asm. スィブルガイド押え (組)	
			No.	Part No.	No.	Part No.	No.	Part No.	No.	Part No.	No.	Part No.
B	1/8	3.2	(1)	400-35896	(19)	226-37656	(32)	103-91852	(39)	226-27152	(45)	226-47051
C	5/32	4.0	(2)	400-35897	(20)	226-37755	-	-	-	-	-	-
D	3/16	4.8	(3)	226-40353	(21)	226-37854	(33)	103-92058	(40)	226-27350	(46)	226-47150
E	7/32	5.6	(4)	226-40452	-	-	-	-	(41)	226-27459	(47)	226-47259
F	1/4	6.4	(5)	226-40551	(22)	226-38050	(34)	103-92256	(42)	226-27558	(48)	226-47358
G	9/32	7.1	(6)	226-40759	(23)	226-38258	-	-	(43)	226-27657	(49)	226-47457
H	5/16	7.9	(7)	226-40858	(24)	226-38357	-	-	(44)	226-27756	(50)	226-47556
K	3/8	9.5	(8)	226-40957	(25)	226-38456	-	-	-	-	-	-
W	7/16	11.1	(9)	226-41054	-	-	-	-	-	-	-	-
L	1/2	12.7	(10)	226-41252	(26)	226-38753	(35)	103-92751	-	-	-	-
M	5/8	15.9	(11)	226-41351	-	-	-	-	-	-	-	-
N	3/4	19.1	(12)	226-41450	(27)	226-38951	(36)	103-93056	-	-	-	-
P	7/8	22.2	(13)	226-41658	(28)	226-39157	(37)	228-44450	-	-	-	-
Q	1	25.4	(14)	226-41757	(29)	226-39256	(38)	228-44559	-	-	-	-
R	1-1/8	28.6	(15)	226-41856	(30)	226-39355	-	-	-	-	-	-
S	1-1/4	31.8	(16)	226-41955	(31)	226-39454	-	-	-	-	-	-
T	1-3/8	34.9	(17)	226-42052	-	-	-	-	-	-	-	-
U	1-1/2	38.1	(18)	226-42151	-	-	-	-	-	-	-	-
Stitch spec. 縫仕様	A				★							
	F								★		★(テープ付け)	
	S		★									
	下送り						★					





Needle gauge size 針 幅			Throat plate (with Taping) 針板 (テープ付)		Throat plate 針板					
Code コード							Lower feed 下送り		Lower feed 下送り	
			No.	Part No.	No.	Part No.	No.	Part No.	No.	Part No.
B	1/8	3.2	(51)	402-32772	(58)	226-25107	(76)	228-45200		-
C	5/32	4.0	(52)	402-32773	(59)	226-25206	-	-		-
D	3/16	4.8	(53)	402-32774	(60)	226-25305	(77)	228-45408		-
E	7/32	5.6	(54)	402-32775	(61)	226-25404	-	-		-
F	1/4	6.4	(55)	402-21496	(62)	226-25503	(78)	228-45606		-
G	9/32	7.1	(56)	402-32776	(63)	226-25602	-	-		-
H	5/16	7.9	(57)	402-32777	(64)	226-25701	-	-		-
K	3/8	9.5	-	-	(65)	226-25800	-	-		-
W	7/16	11.1	-	-	(66)	226-25909	-	-		-
L	1/2	12.7	-	-	(67)	226-26006	-	-	(79)	400-62254
M	5/8	15.9	-	-	(68)	226-26105	-	-		-
N	3/4	19.1	-	-	(69)	226-26204	-	-	(80)	400-62256
P	7/8	22.2	-	-	(70)	226-26303	-	-	(81)	400-62257
Q	1	25.4	-	-	(71)	226-26402	-	-	(82)	400-62258
R	1-1/8	28.6	-	-	(72)	226-26501	-	-		-
S	1-1/4	31.8	-	-	(73)	226-26600	-	-		-
T	1-3/8	34.9	-	-	(74)	226-26709	-	-		-
U	1-1/2	38.1	-	-	(75)	226-26808	-	-		-
Stitch spec. 縫仕様	A									
	F		★		★					
	S									
	下送り						★		★	

No.	品番	品吊	備考	子部品	消耗品	個数
1	40035896	PRESSER FOOT ASM.				1.00
2	40035897	PRESSER FOOT ASM.				1.00
3	22640353	PRESSER FOOT ASM.				1.00
4	22640452	PRESSER FOOT ASM.				1.00
5	22640551	PRESSER FOOT ASM.				1.00
6	22640759	PRESSER FOOT ASM.				1.00
7	22640858	PRESSER FOOT ASM.				1.00
8	22640957	PRESSER FOOT ASM.				1.00
9	22641054	PRESSER FOOT ASM.7/16				1.00
10	22641252	PRESSER FOOT ASM.				1.00
11	22641351	PRESSER FOOT ASM.				1.00
12	22641450	PRESSER FOOT ASM.				1.00
13	22641658	PRESSER FOOT ASM.				1.00
14	22641757	PRESSER FOOT ASM.				1.00
15	22641856	PRESSER FOOT ASM.				1.00
16	22641955	PRESSER FOOT ASM.				1.00
17	22642052	PRESSER FOOT ASM.				1.00
18	22642151	PRESSER FOOT ASM.				1.00
19	22637656	PRESSER FOOT ASM.				1.00
20	22637755	PRESSER FOOT ASM.				1.00
21	22637854	PRESSER FOOT ASM.				1.00
22	22638050	PRESSER FOOT ASM.				1.00
23	22638258	PRESSER FOOT ASM.				1.00
24	22638357	PRESSER FOOT ASM.				1.00
25	22638456	PRESSER FOOT ASM.				1.00
26	22638753	PRESSER FOOT ASM.				1.00
27	22638951	PRESSER FOOT ASM.				1.00
28	22639157	PRESSER FOOT ASM.				1.00
29	22639256	PRESSER FOOT ASM.				1.00
30	22639355	PRESSER FOOT ASM.				1.00
31	22639454	PRESSER FOOT ASM.				1.00
32	10391852	PRESSER FOOT ASM. 1/8				1.00
33	10392058	PRESSER FOOT ASM. 3/16				1.00
34	10392256	PRESSER FOOT ASM. 1/4				1.00
35	10392751	PRESSER FOOT ASM. 1/2				1.00
36	10393056	PRESSER FOOT ASM. 3/4				1.00
37	22844450	COMPENSATING PRESSER ASM.(7/8)				1.00
38	22844559	BOBBIN CASE ASM, HEAVY FABLIC.				1.00
39	22627152	PRESSER FOOT F ASM. 1/8				1.00
40	22627350	F PRESSER FOOT ASM. 3/16				1.00
41	22627459	PRESSER FOOT ASM., 7/32				1.00
42	22627558	PRESSER FOOT F ASM. 1/4				1.00
43	22627657	PRESSER FOOT ASM., F 9/32				1.00
44	22627756	PRESSER FOOT ASM., F 5/16				1.00
45	22647051	SWIVEL GUIDE PRESSER 1/8 ASM.				1.00
46	22647150	GUIDE PRESSER ASM. 3/16				1.00
47	22647259	GUIDE PRESSER ASM. 7/32				1.00
48	22647358	GUIDE PRESSER ASM. 1/4				1.00
49	22647457	GUIDE PRESSER ASM. 9/32				1.00
50	22647556	SWIVEL GUIDE PRESSER 5/16 ASM				1.00

51	40232772	THROAT_PLATE_TAPE_1/8				1.00
52	40232773	THROAT_PLATE_TAPE_5/32				1.00
53	40232774	THROAT_PLATE_TAPE_3/16				1.00
54	40232775	THROAT_PLATE_TAPE_7/32				1.00
55	40221496	THROAT_PLATE				1.00
56	40232776	THROAT_PLATE_TAPE_9/32				1.00
57	40232777	THROAT_PLATE_TAPE_5/16				1.00
58	22625107	THROAT PLATE 1/8 (3.2MM)				1.00
59	22625206	THROAT PLATE 5/32 (4MM)				1.00
60	22625305	THROAT PLATE 3/16 (4.8MM)				1.00
61	22625404	THROAT PLATE 7/32 (5.6MM)				1.00
62	22625503	THROAT PLATE 1/4				1.00
63	22625602	THROAT PLATE 9/32 (7.1MM)				1.00
64	22625701	THROAT PLATE 5/16 (7.9MM)				1.00
65	22625800	THROAT PLATE 3/8 (9.5MM)				1.00
66	22625909	THROT PLATE 7/16 (11.1MM)				1.00
67	22626006	THROAT PLATE 1/2 (12.7MM)				1.00
68	22626105	THROAT PLATE 5/8 (15.9MM)				1.00
69	22626204	THROAT PLATE 3/4 (19.1MM)				1.00
70	22626303	THROAT PLATE 7/8 (22.2MM)				1.00
71	22626402	THROAT PLATE 1 (25.4MM)				1.00
72	22626501	THROAT PLATE 1.1/8 (28.6MM)				1.00
73	22626600	THROAT PLATE 1.1/4 (31.8MM)				1.00
74	22626709	THROAT PLATE 1.3/8 (34.9MM)				1.00
75	22626808	THROAT PLATE 1.1/2 (38.1MM)				1.00
76	22845200	THROAT PLATE, (1/8).				1.00
77	22845408	THROAT PLATE, 3/16.				1.00
78	22845606	THROAT PLATE, (1/4).				1.00
79	40062254	THROAT_PLATE_1/2				1.00
80	40062256	THROAT_PLATE_3/4				1.00
81	40062257	THROAT_PLATE_7/8				1.00
82	40062258	THROAT_PLATE_1				1.00

TABLE OF EXCHANGING GAUGE PARTS (FOR LH-4578C-7)(1)

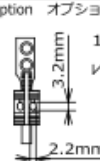
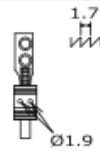
Needle gauge size 針 幅			Throat plate 針板				Needle clamp asm. 針留組	
Code コード							 Hole Type 穴タイプ	
	inch	mm	No.	Part No.	No.	Part No.	No.	Part No.
B	1/8	3.2	①	402-32755	⑰	400-35881	③③	101-47650
C	5/32	4.0	②	402-32756	⑱	400-25485	③④	101-47759
D	3/16	4.8	③	402-32757	⑲	400-25490	③⑤	101-47858
E	7/32	5.6	④	402-32758	⑳	400-25491	③⑥	101-47957
F	1/4	6.4	⑤	402-20201	㉑	400-25492	③⑦	101-48054
G	9/32	7.1	⑥	402-32759	㉒	400-25493	③⑧	101-48153
H	5/16	7.9	⑦	402-32760	㉓	400-25494	③⑨	101-48252
K	3/8	9.5	⑧	402-32761	㉔	400-25495	④①	101-48351
W	7/16	11.1	⑨	402-32762	㉕	400-25496	④②	101-48450
L	1/2	12.7	⑩	402-32763	㉖	400-25498	④③	101-48559
M	5/8	15.9	⑪	402-32764	㉗	400-25499	④④	101-48658
N	3/4	19.1	⑫	402-32765	㉘	400-25500	④⑤	101-48757
P	7/8	22.2	⑬	402-32766	㉙	400-25502	④⑥	101-48856
Q	1	25.4	⑭	402-32767	⑳	400-25503	④⑦	101-48955
R	1-1/8	28.6	⑮	402-32768	㉑	400-25504	④⑧	101-49052
S	1-1/4	31.8	⑯	402-32769	㉒	400-25505	④⑨	101-49151
T	1-3/8	34.9		-		-	④⑩	101-49250
U	1-1/2	38.1		-		-	④⑪	101-49359
Stitch spec. 縫仕様	S					★		
	G			★		★		★

Needle gauge size 針 幅			Feed Dog 送り面							
Code コード					Option オプション 					
	inch	mm	No.	Part No.	No.	Part No.	No.	Part No.	No.	Part No.
B	1/8	3.2		-	⑥⑤	402-32778	⑧①	402-43735	⑨⑥	402-43737
C	5/32	4.0	⑤①	402-32779		-	⑧②	402-43736	⑨⑦	402-43738
D	3/16	4.8	⑤②	400-35891	⑥⑥	400-25831	⑧③	400-61272	⑨⑧	400-25818
E	7/32	5.6	⑤③	400-50009	⑥⑦	400-25832	⑧④	400-61273	⑨⑨	400-25819
F	1/4	6.4	⑤④	400-35892	⑥⑧	400-25833	⑧⑤	400-61274	⑩①	400-26715
G	9/32	7.1	⑤⑤	400-50010	⑦①	400-25834	⑧⑥	400-61275	⑩②	400-25820
H	5/16	7.9	⑤⑥	400-50011	⑦②	400-25835	⑧⑦	400-61276	⑩③	400-25821
K	3/8	9.5	⑤⑦	400-35893	⑦③	400-25836	⑧⑧	400-61277	⑩④	400-25822
W	7/16	11.1		-	⑦④	400-25837		-	⑩⑤	400-25823
L	1/2	12.7	⑤⑧	400-35894	⑦⑤	400-25838	⑧⑨	400-61278	⑩⑥	400-25824
M	5/8	15.9	⑤⑨	400-71912	⑦⑥	400-25839	⑧⑩	400-61279	⑩⑦	400-25825
N	3/4	19.1	⑥①	400-35895	⑦⑦	400-25840	⑧⑪	400-61280	⑩⑧	400-25826
P	7/8	22.2	⑥②	400-71913	⑦⑧	400-25841	⑧⑫	400-61281	⑩⑨	400-25827
Q	1	25.4	⑥③	400-71914	⑦⑨	400-25842	⑧⑬	400-61282	⑩⑩	400-25828
R	1-1/8	28.6	⑥④	400-71915	⑦⑩	400-25843	⑧⑭	400-61283	⑩⑪	400-25829
S	1-1/4	31.8	⑥⑤	400-71916	⑦⑪	400-25844	⑧⑮	400-61284	⑩⑫	400-25830
T	1-3/8	34.9		-		-		-		-
U	1-1/2	38.1		-		-		-		-
Stitch spec. 縫仕様	S					★		★		★
	G			★		★		★		★

The ※ mark is an optional gauge for 3# thread.
※マークは3#糸のオプションゲージです。

No.	品番	品名	備考	子部品	消耗品	個数
1	40232755	THROAT_PLATE_TRIM_G_1/8				1.00
2	40232756	THROAT_PLATE_TRIM_G_5/32				1.00
3	40232757	THROAT_PLATE_TRIM_G_3/16				1.00
4	40232758	THROAT_PLATE_TRIM_G_7/32				1.00
5	40220201	THROAT_PLATE_TRIM_G				1.00
6	40232759	THROAT_PLATE_TRIM_G_9/32				1.00
7	40232760	THROAT_PLATE_TRIM_G_5/16				1.00
8	40232761	THROAT_PLATE_TRIM_G_3/8				1.00
9	40232762	THROAT_PLATE_TRIM_G_7/16				1.00
10	40232763	THROAT_PLATE_TRIM_G_1/2				1.00
11	40232764	THROAT_PLATE_TRIM_G_5/8				1.00
12	40232765	THROAT_PLATE_TRIM_G_3/4				1.00
13	40232766	THROAT_PLATE_TRIM_G_7/8				1.00
14	40232767	THROAT_PLATE_TRIM_G_1				1.00
15	40232768	THROAT_PLATE_TRIM_G_1-1/8				1.00
16	40232769	THROAT_PLATE_TRIM_G_1-1/4				1.00
17	40035881	THROAT_PLATE_TRIM_1/8				1.00
18	40025485	THROAT_PLATE_TRIM_5/32				1.00
19	40025490	THROAT_PLATE_TRIM-3/16				1.00
20	40025491	THROAT_PLATE_TRIM-7/32				1.00
21	40025492	THROAT_PLATE_TRIM-1/4				1.00
22	40025493	THROAT_PLATE_TRIM-9/32				1.00
23	40025494	THROAT_PLATE_TRIM-5/16				1.00
24	40025495	THROAT_PLATE_TRIM-3/8				1.00
25	40025496	THROAT_PLATE_TRIM-7/16				1.00
26	40025498	THROAT_PLATE_TRIM-1/2				1.00
27	40025499	THROAT_PLATE_TRIM-5/8				1.00
28	40025500	THROAT_PLATE_TRIM-3/4				1.00
29	40025502	THROAT_PLATE_TRIM-7/8				1.00
30	40025503	THROAT_PLATE_TRIM-1				1.00
31	40025504	THROAT_PLATE_TRIM-1-1/8				1.00
32	40025505	THROAT_PLATE_TRIM-1-1/4				1.00
33	10147650	NEEDLE_CLAMP_ASM_1/8				1.00
34	10147759	NEEDLE_CLAMP_ASM_5/32				1.00
35	10147858	NEEDLE_CLAMP_ASM_3/16				1.00
36	10147957	NEEDLE_CLAMP_ASM_7/32				1.00
37	10148054	NEEDLE_CLAMP_ASM_1/4				1.00
38	10148153	NEEDLE_CLAMP_ASM_9/32				1.00
39	10148252	NEEDLE_CLAMP_ASM_5/16				1.00
40	10148351	NEEDLE_CLAMP_ASM_3/8				1.00
41	10148450	NEEDLE_CLAMP_ASM_7/16				1.00
42	10148559	NEEDLE_CLAMP_ASM_1/2				1.00
43	10148658	NEEDLE_CLAMP_ASM_5/8				1.00
44	10148757	NEEDLE_CLAMP_ASM_3/4				1.00
45	10148856	NEEDLE_CLAMP_ASM_7/8				1.00
46	10148955	NEEDLE_CLAMP_ASM_1				1.00
47	10149052	NEEDLE_CLAMP_ASM_1-1/8				1.00
48	10149151	NEEDLE_CLAMP_ASM_1-1/4				1.00
49	10149250	NEEDLE_CLAMP_ASM_1-3/8				1.00
50	10149359	NEEDLE_CLAMP_ASM_1-1/2				1.00

51	40232779	FEED_DOG_7G_5/32				1.00
52	40035891	FEED_DOG_TYPE_7G_3/16				1.00
53	40050009	FEED_DOG_TYPE_7G_7/32				1.00
54	40035892	FEED_DOG_TYPE_7G_1/4				1.00
55	40050010	FEED_DOG_TYPE_7G_9/32				1.00
56	40050011	FEED_DOG_TYPE_7G_5/16				1.00
57	40035893	FEED_DOG_TYPE_7G_3/8				1.00
58	40035894	FEED_DOG_TYPE_7G_1/2				1.00
59	40071912	FEED_DOG_7G_5/8				1.00
60	40035895	FEED_DOG_TYPE_7G_3/4				1.00
61	40071913	FEED_DOG_7G_7/8				1.00
62	40071914	FEED_DOG_7G_1				1.00
63	40071915	FEED_DOG_7G_1-1/8				1.00
64	40071916	FEED_DOG_7G_1-1/4				1.00
65	40232778	FEED_DOG_7G_1/8				1.00
66	40025831	FEED_DOG_TYPE_7G_3/16				1.00
67	40025832	FEED_DOG_TYPE_7G_7/32				1.00
68	40025833	FEED_DOG_TYPE_7G_1/4				1.00
69	40220209	FEED_DOG_TYPE_30P				1.00
70	40025834	FEED_DOG_TYPE_7G_9/32				1.00
71	40025835	FEED_DOG_TYPE_7G_5/16				1.00
72	40025836	FEED_DOG_TYPE_7G_3/8				1.00
73	40025837	FEED_DOG_TYPE_7G_7/16				1.00
74	40025838	FEED_DOG_TYPE_7G_1/2				1.00
75	40025839	FEED_DOG_TYPE_7G_5/8				1.00
76	40025840	FEED_DOG_TYPE_7G_3/4				1.00
77	40025841	FEED_DOG_TYPE_7G_7/8				1.00
78	40025842	FEED_DOG_TYPE_7G_1				1.00
79	40025843	FEED_DOG_TYPE_7G_1-1/8				1.00
80	40025844	FEED_DOG_TYPE_7G_1-1/4				1.00
81	40243735	FEED_DOG_7S_1/8				1.00
82	40243736	FEED_DOG_7S_5/32				1.00
83	40061272	FEED_DOG_TYPE-S 3/16				1.00
84	40061273	FEED_DOG_TYPE-S 7/32				1.00
85	40061274	FEED_DOG_TYPE-S 1/4				1.00
86	40061275	FEED_DOG_TYPE-S 9/32				1.00
87	40061276	FEED_DOG_TYPE-S 5/16				1.00
88	40061277	FEED_DOG_TYPE-S 3/8				1.00
89	40061278	FEED_DOG_TYPE-S 1/2				1.00
90	40061279	FEED_DOG_TYPE-S 5/8				1.00
91	40061280	FEED_DOG_TYPE-S 3/4				1.00
92	40061281	FEED_DOG_TYPE-S 7/8				1.00
93	40061282	FEED_DOG_TYPE-S 1				1.00
94	40061283	FEED_DOG_TYPE-S 1 1/8				1.00
95	40061284	FEED_DOG_TYPE-S 1 1/4				1.00
96	40243737	FEED_DOG_7S_1/8				1.00
97	40243738	FEED_DOG_7S_5/32				1.00
98	40025818	FEED_DOG_TYPE-S 3/16				1.00
99	40025819	FEED_DOG_TYPE-S 7/32				1.00
100	40026715	FEED_DOG_TYPE-S 1/4				1.00
101	40025820	FEED_DOG_TYPE-S 9/32				1.00

102	40025821	FEED_DOG_TYPE-S 5/16				1.00
103	40025822	FEED_DOG_TYPE-S 3/8				1.00
104	40025823	FEED_DOG_TYPE-S 7/16				1.00
105	40025824	FEED_DOG_TYPE-S 1/2				1.00
106	40025825	FEED_DOG_TYPE-S 5/8				1.00
107	40025826	FEED_DOG_TYPE-S 3/4				1.00
108	40025827	FEED_DOG_TYPE-S 7/8				1.00
109	40025828	FEED_DOG_TYPE-S 1				1.00
110	40025829	FEED_DOG_TYPE-S 1-1/8				1.00
111	40025830	FEED_DOG_TYPE-S 1-1/4				1.00

TABLE OF EXCHANGING GAUGE PARTS (FOR LH-4578C-7)(2)

Code コード	Needle gauge size 針 幅		Presser foot asm. 押え (組)				Swivel guide Presser asm. スワivelガイド押え (組)			
	inch	mm	Tip-divided 移動式先割れ 2.4mm		Tip-divided 移動式先割れ 2mm		コバ 2mm		コバ 3mm	
B	1/8	3.2	—	(16)	400-35896	(34)	402-29469	—	—	
C	5/32	4.0	(1)	400-71909	(17)	400-35897	—	—	—	
D	3/16	4.8	(2)	228-16557	(18)	226-40353	(35)	402-29461	(38)	400-95293
E	7/32	5.6	(3)	228-16656	(19)	226-40452	—	—	—	
F	1/4	6.4	(4)	228-16755	(20)	226-40551	(36) (37) ※	402-29459 402-20207	(39)	400-94776
G	9/32	7.1	(5)	228-16854	(21)	226-40759	—	—	—	
H	5/16	7.9	(6)	228-16953	(22)	226-40858	—	—	—	
K	3/8	9.5	(7)	228-17050	(23)	226-40957	—	—	—	
W	7/16	11.1	(8)	400-33941	(24)	226-41054	—	—	—	
L	1/2	12.7	(9)	228-17159	(25)	226-41252	—	—	—	
M	5/8	15.9	(10)	400-33945	(26)	226-41351	—	—	—	
N	3/4	19.1	(11)	400-33947	(27)	226-41450	—	—	—	
P	7/8	22.2	(12)	400-33949	(28)	226-41658	—	—	—	
Q	1	25.4	(13)	400-33951	(29)	226-41757	—	—	—	
R	1-1/8	28.6	(14)	400-33953	(30)	226-41856	—	—	—	
S	1-1/4	31.8	(15)	400-33955	(31)	226-41955	—	—	—	
T	1-3/8	34.9	—	—	(32)	226-42052	—	—	—	
U	1-1/2	38.1	—	—	(33)	226-42151	—	—	—	
Stitch spec. 縫 仕 様	S		★				★			
	G		★				★			

The ※ mark is an optional gauge for 3# thread.
※マークは3#糸のオプションゲージです。

Code コード	Needle gauge size 針 幅		Sliding plate asm. 滑り板組		Sliding plate asm. (Front) 滑り板(前) 組	
	inch	mm	No.	Part No.	No.	Part No.
B	1/8	3.2	—	—	—	—
C	5/32	4.0	—	—	—	—
D	3/16	4.8	—	—	—	—
E	7/32	5.6	—	—	—	—
F	1/4	6.4	(40)	402-20206	—	—
G	9/32	7.1	—	—	—	—
H	5/16	7.9	—	—	—	—
K	3/8	9.5	—	—	—	—
W	7/16	11.1	—	—	(44)	400-42880
L	1/2	12.7	—	—	—	—
M	5/8	15.9	(41)	402-22670	—	—
N	3/4	19.1	—	—	—	—
P	7/8	22.2	—	—	—	—
Q	1	25.4	(42)	402-22671	—	—
R	1-1/8	28.6	—	—	—	—
S	1-1/4	31.8	(43)	402-22672	—	—
T	1-3/8	34.9	—	—	—	—
U	1-1/2	38.1	—	—	—	—
Stitch spec. 縫 仕 様	S		★		★	
	G		★		★	

No.	品番	品吊	備考	子部品	消耗品	個数
1	40071909	PRESSER_FOOT_ASM_G_5/32				1.00
2	22816557	TIP-DIVIDED PRESSER ASM. 3/16				1.00
3	22816656	TIP-DIVIDED PRESSER ASM. 7/32				1.00
4	22816755	PRESSER FOOT ASM. 1/4				1.00
5	22816854	TIP-DIVIDED PRESSER ASM. 9/32				1.00
6	22816953	TIP-DIVIDED PRESSER ASM. 5/16				1.00
7	22817050	PRESSER FOOT ASM. D=2.4 (3/8)				1.00
8	40033941	TIP-DIVIDED_PRESSER_ASM_7/16				1.00
9	22817159	PRESSER FOOT ASM. D=2.4 (1/2)				1.00
10	40033945	TIP-DIVIDED_PRESSER_ASM_5/8				1.00
11	40033947	TIP-DIVIDED_PRESSER_ASM_3/4				1.00
12	40033949	TIP-DIVIDED_PRESSER_ASM_7/8				1.00
13	40033951	TIP-DIVIDED_PRESSER_ASM_1				1.00
14	40033953	TIP-DIVIDED_PRESSER_ASM_1_1/8				1.00
15	40033955	TIP-DIVIDED_PRESSER_ASM_1_1/4				1.00
16	40035896	PRESSER FOOT ASM.				1.00
17	40035897	PRESSER FOOT ASM.				1.00
18	22640353	PRESSER FOOT ASM.				1.00
19	22640452	PRESSER FOOT ASM.				1.00
20	22640551	PRESSER FOOT ASM.				1.00
21	22640759	PRESSER FOOT ASM.				1.00
22	22640858	PRESSER FOOT ASM.				1.00
23	22640957	PRESSER FOOT ASM.				1.00
24	22641054	PRESSER FOOT ASM.7/16				1.00
25	22641252	PRESSER FOOT ASM.				1.00
26	22641351	PRESSER FOOT ASM.				1.00
27	22641450	PRESSER FOOT ASM.				1.00
28	22641658	PRESSER FOOT ASM.				1.00
29	22641757	PRESSER FOOT ASM.				1.00
30	22641856	PRESSER FOOT ASM.				1.00
31	22641955	PRESSER FOOT ASM.				1.00
32	22642052	PRESSER FOOT ASM.				1.00
33	22642151	PRESSER FOOT ASM.				1.00
34	40229469	ASSY_PRESSER_FOOT_G1/8				1.00
35	40229461	ASSY_PRESSER_FOOT_G3/16				1.00
36	40229459	ASSY_PRESSER_FOOT_G_1/4				1.00
37	40220207	ASSY_PRESSER_FOOT_3OP				1.00
38	40095293	ASSY_PRESSER_FOOT_G3/16				1.00
39	40094776	ASSY_PRESSER_FOOT_G1/4				1.00
40	40220206	ASSY_SLIDE_PLANTE-A				1.00
41	40222670	ASSY_SLIDE_PLATE-B				1.00
42	40222671	ASSY_SLIDE_PLATE-C				1.00
43	40222672	ASSY_SLIDE_PLATE-D				1.00
44	40042880	ASSY_SLIDE_PLATE_F				1.00

TABLE OF EXCHANGING GAUGE PARTS (FOR LH-4588C-7)(1)

Needle gauge size 針 幅			Feed dog 送り 歯							
Code コード	Needle gauge size 針 幅		Standard		Option オプション		Standard		Option オプション	
	inch	mm	No.	Part No.	No.	Part No.	No.	Part No.	No.	Part No.
B	1/8	3.2		-	(13)	402-32778	(26)	402-43735	(39)	402-43737
C	5/32	4.0	(1)	402-32779		-	(27)	402-43736	(40)	402-43738
D	3/16	4.8	(2)	400-35891	(14)	400-25831	(28)	400-61272	(41)	400-25818
E	7/32	5.6	(3)	400-50009	(15)	400-25832	(29)	400-61273	(42)	400-25819
F	1/4	6.4	(4)	400-35892	(16)	400-25833	(30)	400-61274	(43)	400-26715
					(17)	※ 402-20209				
G	9/32	7.1	(5)	400-50010	(18)	400-25834	(31)	400-61275	(44)	400-25820
H	5/16	7.9	(6)	400-50011	(19)	400-25835	(32)	400-61276	(45)	400-25821
K	3/8	9.5	(7)	400-35893	(20)	400-25836	(33)	400-61277	(46)	400-25822
L	1/2	12.7	(8)	400-35984	(21)	400-25838	(34)	400-61278	(47)	400-25824
M	5/8	15.9	(9)	400-71912	(22)	400-25839	(35)	400-61279	(48)	400-25825
N	3/4	19.1	(10)	400-35895	(23)	400-25840	(36)	400-61280	(49)	400-25826
P	7/8	22.2	(11)	400-71913	(24)	400-25841	(37)	400-61281	(50)	400-25827
Q	1	25.4	(12)	400-71914	(25)	400-25842	(38)	400-61282	(51)	400-25828
Stitch spec. 縫 仕 様	S						★		★	
	G		★				★			

The ※ mark is an optional gauge for 3# thread.

※マークは3#糸のオプションゲージです。

Needle gauge size 針 幅			Throat plate 針 板				Preset foot asm. 押 え (組)			
Code コード	Needle gauge size 針 幅		Standard		Standard		Tip-divided 移動式先割れ		Tip-divided 移動式先割れ	
	inch	mm	No.	Part No.	No.	Part No.	No.	Part No.	No.	Part No.
B	1/8	3.2	(52)	402-32755	(65)	400-35881	(78)	400-35896	(91)	400-35896
C	5/32	4.0	(53)	402-32756	(66)	400-25485	(79)	400-71909	(92)	400-35897
D	3/16	4.8	(54)	402-32757	(67)	400-25490	(80)	228-16557	(93)	226-40353
E	7/32	5.6	(55)	402-32758	(68)	400-25491	(81)	228-16656	(94)	226-40452
F	1/4	6.4	(56)	402-20201	(69)	400-25492	(82)	228-16755	(95)	226-40551
G	9/32	7.1	(57)	402-32759	(70)	400-25493	(83)	228-16854	(96)	226-40759
H	5/16	7.9	(58)	402-32760	(71)	400-25494	(84)	228-16953	(97)	226-40858
K	3/8	9.5	(59)	402-32761	(72)	400-25495	(85)	228-17050	(98)	226-40957
L	1/2	12.7	(60)	402-32763	(73)	400-25498	(86)	228-17159	(99)	226-41252
M	5/8	15.9	(61)	402-32764	(74)	400-25499	(87)	400-33945	100	226-41351
N	3/4	19.1	(62)	402-32765	(75)	400-25500	(88)	400-33947	101	226-41450
P	7/8	22.2	(63)	402-32766	(76)	400-25502	(89)	400-33949	102	226-41658
Q	1	25.4	(64)	402-32767	(77)	400-25503	(90)	400-33951	103	226-41757
Stitch spec. 縫 仕 様	S						★		★	
	G		★				★			

No.	品番	品吊	備考	子部品	消耗品	個数
1	40232779	FEED_DOG_7G_5/32				1.00
2	40035891	FEED_DOG_TYPE_7G_3/16				1.00
3	40050009	FEED_DOG_TYPE_7G_7/32				1.00
4	40035892	FEED_DOG_TYPE_7G_1/4				1.00
5	40050010	FEED_DOG_TYPE_7G_9/32				1.00
6	40050011	FEED_DOG_TYPE_7G_5/16				1.00
7	40035893	FEED_DOG_TYPE_7G_3/8				1.00
8	40035894	FEED_DOG_TYPE_7G_1/2				1.00
9	40071912	FEED_DOG_7G_5/8				1.00
10	40035895	FEED_DOG_TYPE_7G_3/4				1.00
11	40071913	FEED_DOG_7G_7/8				1.00
12	40071914	FEED_DOG_7G_1				1.00
13	40232778	FEED_DOG_7G_1/8				1.00
14	40025831	FEED_DOG_TYPE_7G_3/16				1.00
15	40025832	FEED_DOG_TYPE_7G_7/32				1.00
16	40025833	FEED_DOG_TYPE_7G_1/4				1.00
17	40220209	FEED_DOG_TYPE_3OP				1.00
18	40025834	FEED_DOG_TYPE_7G_9/32				1.00
19	40025835	FEED_DOG_TYPE_7G_5/16				1.00
20	40025836	FEED_DOG_TYPE_7G_3/8				1.00
21	40025838	FEED_DOG_TYPE_7G_1/2				1.00
22	40025839	FEED_DOG_TYPE_7G_5/8				1.00
23	40025840	FEED_DOG_TYPE_7G_3/4				1.00
24	40025841	FEED_DOG_TYPE_7G_7/8				1.00
25	40025842	FEED_DOG_TYPE_7G_1				1.00
26	40243735	FEED_DOG_7S_1/8				1.00
27	40243736	FEED_DOG_7S_5/32				1.00
28	40061272	FEED_DOG_TYPE-S 3/16				1.00
29	40061273	FEED_DOG_TYPE-S 7/32				1.00
30	40061274	FEED_DOG_TYPE-S 1/4				1.00
31	40061275	FEED_DOG_TYPE-S 9/32				1.00
32	40061276	FEED_DOG_TYPE-S 5/16				1.00
33	40061277	FEED_DOG_TYPE-S 3/8				1.00
34	40061277	FEED_DOG_TYPE-S 3/8				1.00
35	40061279	FEED_DOG_TYPE-S 5/8				1.00
36	40061280	FEED_DOG_TYPE-S 3/4				1.00
37	40061281	FEED_DOG_TYPE-S 7/8				1.00
38	40061282	FEED_DOG_TYPE-S 1				1.00
39	40243737	FEED_DOG_7S_1/8				1.00
40	40243738	FEED_DOG_7S_5/32				1.00
41	40025818	FEED_DOG_TYPE-S 3/16				1.00
42	40025819	FEED_DOG_TYPE-S 7/32				1.00
43	40026715	FEED_DOG_TYPE-S 1/4				1.00
44	40025820	FEED_DOG_TYPE-S 9/32				1.00
45	40025821	FEED_DOG_TYPE-S 5/16				1.00
46	40025822	FEED_DOG_TYPE-S 3/8				1.00
47	40025824	FEED_DOG_TYPE-S 1/2				1.00
48	40025825	FEED_DOG_TYPE-S 5/8				1.00
49	40025826	FEED_DOG_TYPE-S 3/4				1.00
50	40025827	FEED_DOG_TYPE-S 7/8				1.00

51	40025828	FEED_DOG_TYPE-S 1				1.00
52	40232755	THROAT_PLATE_TRIM_G_1/8				1.00
53	40232756	THROAT_PLATE_TRIM_G_5/32				1.00
54	40232757	THROAT_PLATE_TRIM_G_3/16				1.00
55	40232758	THROAT_PLATE_TRIM_G_7/32				1.00
56	40220201	THROAT_PLATE_TRIM_G				1.00
57	40232759	THROAT_PLATE_TRIM_G_9/32				1.00
58	40232760	THROAT_PLATE_TRIM_G_5/16				1.00
59	40232761	THROAT_PLATE_TRIM_G_3/8				1.00
60	40232763	THROAT_PLATE_TRIM_G_1/2				1.00
61	40232764	THROAT_PLATE_TRIM_G_5/8				1.00
62	40232765	THROAT_PLATE_TRIM_G_3/4				1.00
63	40232766	THROAT_PLATE_TRIM_G_7/8				1.00
64	40232767	THROAT_PLATE_TRIM_G_1				1.00
65	40035881	THROAT_PLATE_TRIM_1/8				1.00
66	40025485	THROAT_PLATE_TRIM 5/32				1.00
67	40025490	THROAT_PLATE_TRIM-3/16				1.00
68	40025491	THROAT_PLATE_TRIM-7/32				1.00
69	40025492	THROAT_PLATE_TRIM-1/4				1.00
70	40025493	THROAT_PLATE_TRIM-9/32				1.00
71	40025494	THROAT_PLATE_TRIM-5/16				1.00
72	40025495	THROAT_PLATE_TRIM-3/8				1.00
73	40025498	THROAT_PLATE_TRIM-1/2				1.00
74	40025499	THROAT_PLATE_TRIM-5/8				1.00
75	40025500	THROAT_PLATE_TRIM-3/4				1.00
76	40025502	THROAT_PLATE_TRIM-7/8				1.00
77	40025503	THROAT_PLATE_TRIM-1				1.00
78	40035896	PRESSER FOOT ASM.				1.00
79	40071909	PRESSER_FOOT_ASM_G_5/32				1.00
80	22816557	TIP-DIVIDED PRESSER ASM. 3/16				1.00
81	22816656	TIP-DIVIDED PRESSER ASM. 7/32				1.00
82	22816755	PRESSER FOOT ASM. 1/4				1.00
83	22816854	TIP-DIVIDED PRESSER ASM. 9/32				1.00
84	22816953	TIP-DIVIDED PRESSER ASM. 5/16				1.00
85	22817050	PRESSER FOOT ASM. D=2.4 (3/8)				1.00
86	22817159	PRESSER FOOT ASM. D=2.4 (1/2)				1.00
87	40033945	TIP-DIVIDED_PRESSER_ASM_5/8				1.00
88	40033947	TIP-DIVIDED_PRESSER_ASM_3/4				1.00
89	40033949	TIP-DIVIDED_PRESSER_ASM_7/8				1.00
90	40033951	TIP-DIVIDED_PRESSER_ASM_1				1.00
91	40035896	PRESSER FOOT ASM.				1.00
92	40035897	PRESSER FOOT ASM.				1.00
93	22640353	PRESSER FOOT ASM.				1.00
94	22640452	PRESSER FOOT ASM.				1.00
95	22640551	PRESSER FOOT ASM.				1.00
96	22640759	PRESSER FOOT ASM.				1.00
97	22640858	PRESSER FOOT ASM.				1.00
98	22640957	PRESSER FOOT ASM.				1.00
99	22641252	PRESSER FOOT ASM.				1.00
100	22641351	PRESSER FOOT ASM.				1.00
101	22641450	PRESSER FOOT ASM.				1.00

102	22641658	PRESSER FOOT ASM.				1.00
103	22641757	PRESSER FOOT ASM.				1.00

TABLE OF EXCHANGING GAUGE PARTS (FOR LH-4588C-7)(2)

Needle gauge size 針 幅	Swivel guide Presser asm. スワイブガイド押え (組)				Sliding plate asm. (Left) 滑り板(左)組		Sliding plate asm. (Front) 滑り板(前)組			
	コバ2mm		コバ3mm							
Code コード	inch	mm	No.	Part No.	No.	Part No.	No.	Part No.		
B	1/8	3.2	①	402-29469		—	⑦	402-20206		
C	5/32	4.0		—		—				
D	3/16	4.8	②	402-29461	⑤	400-95293				
E	7/32	5.6		—		—				
F	1/4	6.4	③ ④	402-29459 ※ 402-20207	⑥	400-94776			⑩	400-42880
G	9/32	7.1		—		—				
H	5/16	7.9		—		—				
K	3/8	9.5		—		—				
L	1/2	12.7		—		—			⑧	402-22670
M	5/8	15.9		—		—				
N	3/4	19.1		—		—				
P	7/8	22.2		—		—	⑨	402-22671		
Q	1	25.4		—		—				
Stitch spec. 縫仕様	S						★	★		
	G		★		★		★	★		

The ※ mark is an optional gauge for 3# thread.
※マークは3#糸のオプションゲージです。

Needle gauge size 針 幅	Needle clamp asm.(for DP 5) 針 留組(DP 5用)				Needle clamp asm.(for DP 17) 針 留組(DP 17用)			
	Needle clamp asm. (Left) 針 留(左)組		Needle clamp asm. (Right) 針 留(右)組		Needle clamp asm. (Left) 針 留(左)組		Needle clamp asm. (Right) 針 留(右)組	
Code コード	inch	mm	No.	Part No.	No.	Part No.	No.	Part No.
B	1/8	3.2	⑪	B1402-528-BA0-A	⑭	B1402-528-BA0-A	⑳	B1402-526-BA0-A
C	5/32	4.0	⑫	B1402-528-CA0-A	⑮	B1402-528-CA0-A	㉑	B1402-526-CA0-A
D	3/16	4.8	⑬	B1402-528-DAL-A	⑯	B1402-528-DAR-A	㉒	B1402-526-DAL-A
E	7/32	5.6	⑭	B1402-528-EAL	⑰	B1402-528-EAR	㉓	102-28559
F	1/4	6.4	⑮	B1402-528-FAL-A	⑱	B1402-528-FAR-A	㉔	102-28567
G	9/32	7.1	⑯	B1402-528-GAL	⑲	B1402-528-GAR	㉕	102-28856
H	5/16	7.9	⑰	B1402-528-HAL-A	⑳	B1402-528-HAR-A	㉖	102-28864
K	3/8	9.5	⑱	B1402-528-KAL-A	㉑	B1402-528-KAR-A	㉗	102-28963
L	1/2	12.7	⑲	B1402-528-LAL	㉒	B1402-528-LAR	㉘	—
M	5/8	15.9	⑳	B1402-528-MAL	㉓	B1402-528-MAR	㉙	—
N	3/4	19.1	㉑	B1402-528-NAL	㉔	B1402-528-NAR	—	—
P	7/8	22.2	㉒	B1402-528-PAL	㉕	B1402-528-PAR	—	—
Q	1	25.4	㉓	B1402-528-QAL	㉖	B1402-528-QAR	㉚	102-29151
Stitch spec. 縫仕様	S			★		★		★
	G			★		★		★

No.	品番	品吊	備考	子部品	消耗品	個数
1	40229469	ASSY_PRESSER_FOOT_G1/8				1.00
2	40229461	ASSY_PRESSER_FOOT_G3/16				1.00
3	40229459	ASSY_PRESSER_FOOT_G_1/4				1.00
4	40220207	ASSY_PRESSER_FOOT_3OP				1.00
5	40095293	ASSY_PRESSER_FOOT_G3/16				1.00
6	40094776	ASSY_PRESSER_FOOT_G1/4				1.00
7	40220206	ASSY_SLIDE_PLANTE-A				1.00
8	40222670	ASSY_SLIDE_PLATE-B				1.00
9	40222671	ASSY_SLIDE_PLATE-C				1.00
10	40042880	ASSY_SLIDE_PLATE_F				1.00
11	B1402528BA0A	NEEDLE CLAMP ASM. 1/8				1.00
12	B1402528CA0A	NEEDLE CLAMP ASM. 5/32				1.00
13	B1402528DALA	NEEDLE CLAMP ASM. LEFT				1.00
14	B1402528EAL	NEEDLE CLAMP ASM. 7/32				1.00
15	B1402528FALA	NEEDLE CLAMP ASM. 1/4				1.00
16	B1402528GAL	NEEDLE CLAMP ASM., LEFT				1.00
17	B1402528HALA	NEEDLE CLAMP ASM. 5/16				1.00
18	B1402528KALA	NEEDLE CLAMP ASM. 3/8				1.00
19	B1402528LAL	NEEDLE CLAMP ASM., LEFT 1/2				1.00
20	B1402528MAL	NEEDLE CLAMP ASM., LEFT 5/8				1.00
21	B1402528NAL	NEEDLE CLAMP ASM., LEFT 3/4				1.00
22	B1402528PAL	NEEDLE CLAMP ASM. LEFT 7/8				1.00
23	B1402528QAL	NEEDLE CLAMP ASM., LEFT 1				1.00
24	B1402528BA0A	NEEDLE CLAMP ASM. 1/8				1.00
25	B1402528CA0A	NEEDLE CLAMP ASM. 5/32				1.00
26	B1402528DARA	NEEDLE CLAMP ASM. RIGHT				1.00
27	B1402528EAR	NEEDLE CLAMP ASM. 7/32				1.00
28	B1402528FARA	NEEDLE CLAMP ASM. 1/4				1.00
29	B1402528GAR	NEEDLE CLAMP ASM., RIGHT				1.00
30	B1402528HARA	NEEDLE CLAMP ASM. 5/16				1.00
31	B1402528KARA	NEEDLE CLAMP ASM. 3/8				1.00
32	B1402528LAR	NEEDLE CLAMP ASM., RIGHT 1/2				1.00
33	B1402528MAR	NEEDLE CLAMP ASM., RIGHT 5/8				1.00
34	B1402528NAR	NEEDLE CLAMP ASM., RIGHT 3/4				1.00
35	B1402528PAR	NEEDLE CLAMP ASM. RIGHT 7/8				1.00
36	B1402528QAR	NEEDLE CLAMP ASM., RIGHT 1				1.00
37	B1402526BA0A	NEEDLE CLAMP ASM. 1/8				1.00
38	B1402526CA0A	NEEDLE CLAMP ASM. 5/32				1.00
39	B1402526DALA	NEEDLE CLAMP LEFT ASM. 3/16				1.00
40	10228559	NEEDLE CLAMP ASM. LEFT 7/32				1.00
41	B1402526FALA	NEEDLE CLAMP LEFT ASM. 1/4				1.00
42	B1402526GALA	NEEDLE CLAMP LEFT ASM. 9/32				1.00
43	B1402526HALA	NEEDLE CLAMP LEFT ASM. 5/16				1.00
44	B1402526KALA	NEEDLE CLAMP LEFT ASM. 3/8				1.00
45	B1402526LALA	NEEDLE CLAMP LEFT ASM.				1.00
46	10228856	NEEDLE CLAMP ASM. LEFT 5/8				1.00
47	10228955	NEEDLE CLAMP ASM. LEFT 3/4				1.00
48	10229151	NEEDLE CLAMP ASM. LEFT 1				1.00
49	B1402526BA0A	NEEDLE CLAMP ASM. 1/8				1.00
50	B1402526CA0A	NEEDLE CLAMP ASM. 5/32				1.00

51	B1402526DARA	NEEDLE CLAMP RIGHT ASM. 3/16				1.00
52	10228567	NEEDLE CLAMP ASM. RIGHT 7/32				1.00
53	B1402526FARA	NEEDLE CLAMP RIGHT ASM. 1/4				1.00
54	B1402526GARA	NEEDLE CLAMP RIGHT ASM. 9/32				1.00
55	B1402526HARA	NEEDLE CLAMP RIGHT ASM. 5/16				1.00
56	B1402526KARA	NEEDLE CLAMP RIGHT ASM. 3/8				1.00
57	B1402526LARA	NEEDLE CLAMP RIGHT ASM.				1.00
58	10228864	NEEDLE CLAMP ASM. RIGHT 5/8				1.00
59	10228963	NEEDLE CLAMP ASM. RIGHT 3/4				1.00
60	10229169	NEEDLE CLAMP ASM. RIGHT 1				1.00

SPECIAL ORDER PARTS

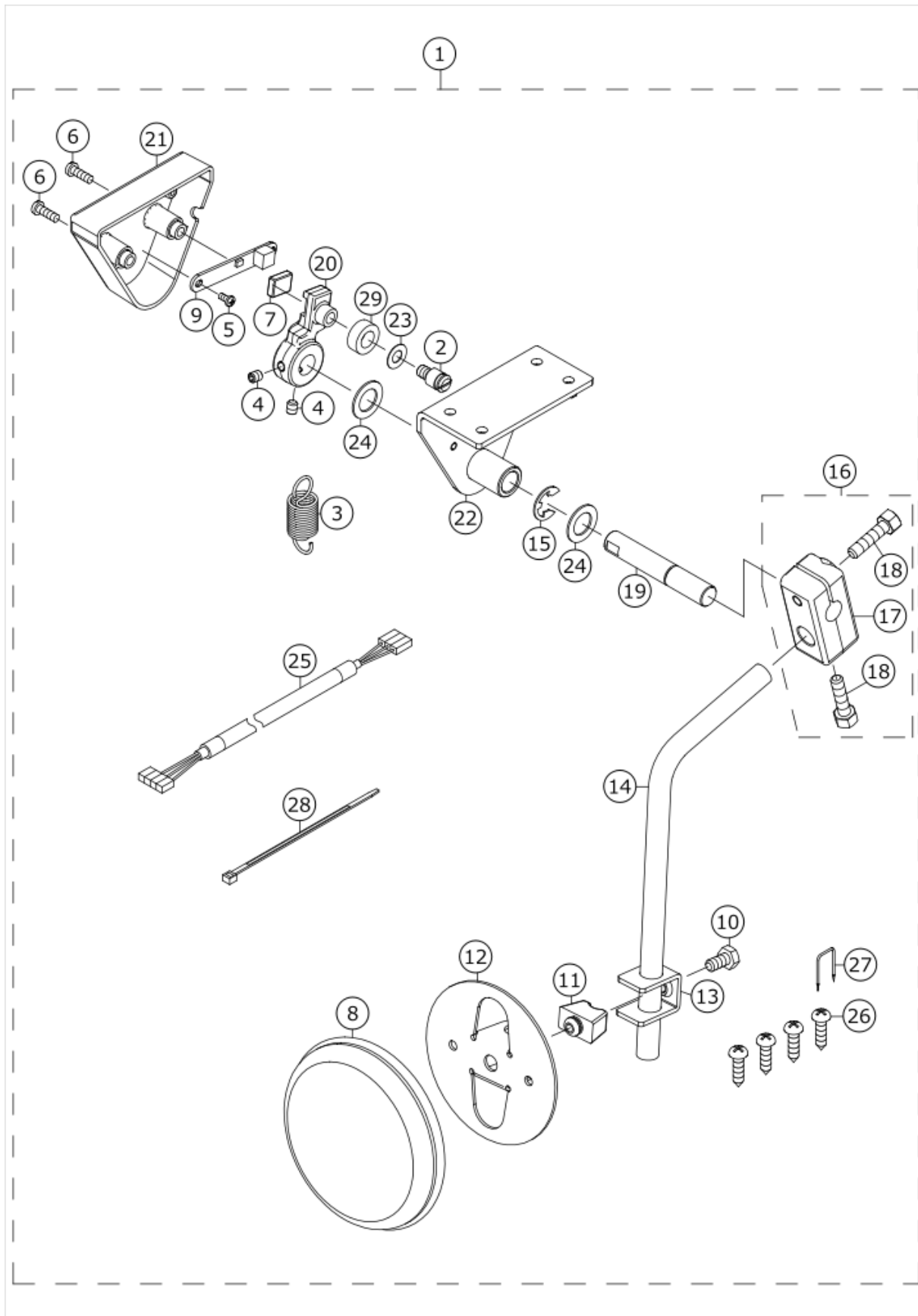

No.	品番	品名	備考	子部品	消耗品	個数
1	40206843	KNEE LIFTER ASSY				1.00
2	26220707	SPRING HOOK		*		1.00
3	40201424	KNEE UPPER SPRING		*		1.00
4	SM8050612TP	SCREW M5X6		*		2.00
5	ST4030551SN	SCREW		*		2.00
6	SM4041255SP	SCREW M4 L=12		*		2.00
7	40206840	KNEE UPPER MAGNET		*		1.00
8	22934509	KNEE PAD PLATE COVER		*		1.00
9	40206841	KNEE UPPER PCB		*		1.00
10	SM9061203SE	SCREW M6 L=12		*		1.00
11	22934400	KNEE PAD PLATE RUBBER		*		1.00
12	22934202	KNEE PAD PLATE		*		1.00
13	22934301	KNEE PAD PLATE SUPPORT		*		1.00
14	22934608	KNEE PAD UPRIGHT SHAFT		*		1.00
15	RE0900000K0	E-RING 9		*		1.00
16	22932453	BRACKET ASM.		*		1.00
17	22932404	BRACKET		*		1.00
18	22934707	SCREW		*		2.00
19	40200727	KNEE LIFTER SHAFT		*		1.00
20	40200725	PRESSER LIFT CRANK		*		1.00
21	40200729	KNEE LIFTER COVER		*		1.00
22	40200731	KNEE LIFTER BASE ASSY		*		1.00
23	WP0650416UZ	WASHER 6.5X13X0.4		*		1.00
24	WP1221016SP	WASHER		*		2.00
25	40206842	KNEE LIFTER CORD		*		1.00
26	SK3512001SE	WOOD SCREW D=5.1 L=20		*		4.00
27	MAO11532000	CORD STAPLE		*		1.00
28	EA9500B0100	CABLE BAND		*		1.00
29	BT1600101EB	URETHANE TUBE BLACK 16X10		*		0.05

HOW TO MAKE USE OF THIS PARTS LIST

1.Explanation of codes

1)"*"mark.....means this part is changed from the previous parts book.

As to the details of the change, refer to the "List for information of change".

2)"#01".....refer to "Note" explanation at bottom of page.

2.Codes on the "Qty" column

· Each numeral indicates the number of parts required.

· "0.1" and "2.5" indicate the length (in meters) of the respective parts.

3.Parentheses mean that the corresponding part is a subpart that constructs an assembly part.

4.Dotted lines on the Figures indicate assembly parts.

5.As to the parts with marks of "☆"(consumable parts) and "◎"(optional parts)on the respective parts, it is recommended to prepare spares.

1 ."注記"欄の記号説明

1) "*"印.....前回のパーツブックに比較して今回変更された部品を意味します。

変更内容は、"変更情報リスト"を参照してください。

2) "#01".....ページ下の"注記"の説明を参照してください。

2.数量欄の数字は、個数を表し、0.1、2.5等の数値は、長さ（単位メートル）を表します。

3.数量欄の（ ）は、組部品を構成している子部品であることを意味します。

4.イラストページの-----枠は、組構成であることを意味します。

5.リストページの"☆"（消耗部品）、"◎"（オプション部品）の印がついた部品は、予備を準備しておくことをお奨めします。