

*Revolutionize Production through
worker creativity by pegasus!*

EX SERIES

EX3200N Series パッカリング防止機能付き安全縫いミシン
Safety stitch machines with
puckering preventive capability

EX5200N Series パッカリング防止機能付きオーバーロックミシン
Overedgers with puckering preventive capability

Specific Parts Catalog

June, 1994
Cat.No.9669



パーツカタログの見方

■このパーツカタログは、1994年6月製造中のEX3200N・EX5200Nシリーズミシンの専用部品のみを次の要領で編集しています。

※専用部品以外の部品は、EX3200・EX5200シリーズの特定のサブクラスと同じ部品を使用しています。

下記のサブクラス対照表を参照して、EXシリーズパーツブックも合わせてご覧ください。(Cat. No. 9605 △)

■2~7頁には部品を機構別に収録し、左頁が部品の分解図、右頁がパーツリストになっています。

また、部品分解図に付されている番号は、パーツリストのREF. NO.(参照番号)を示しています。

■ゲージパーツ表

これらの部品は、特定の形式にのみ使用されている部品です。8~9頁に一括して記載しています。

■10頁以降には部品番号インデックスを記載し、部品番号だけで、その図解、名称などが容易に引き出せます。

■部品を御注文いただくときは、必ず部品番号だけを明示して下さい。

なお、このパーツカタログの記載事項は改良により、予告なく変更されることがありますので、あらかじめご了承ください。

INTRODUCTION

■ This parts book contains only specific parts for the EX3200N・EX5200N Series that were manufactured in June, 1994.

※ Other parts are common in the subclasses between EX3200・EX5200 and EX3200N・EX5200N Series except the above-mentioned specific parts. Therefore refer to the comparison table below and then the EX Series parts book (Cat.No.9605 △) for other parts.

■ The parts classified by each mechanism are shown on pages 2 ~ 7. A page on left shows the breakdown of the parts comprising the mechanism and a page on right the parts list. The numbers given to each illustration are the REF.NOs. on the parts list.

■ Gauge parts list

Gauge parts shown on pages 8~9 are used only for the specific type of machine.

■ A numeric index of the parts is attached to page 10 on and after. The illustration and/or description of the required part can be easily referred to by the part number.

■ Always give the part numbers when ordering parts.

The contents of this parts book are subject to change to without notice.

サブクラス対照表 (Subclass comparison table)

EX3200N Series	EX3200 Series	EX5200N Series	EX5200 Series
^(15N) EX3216N-01/222 →	⁽¹⁵⁾ EX3216-01A/222	EX5204N-01/232 →	EX5204-01/223
^(15N) EX3216N-01/232 →	⁽¹⁵⁾ EX3216-01A/222	EX5214N-01/282 →	EX5214-01/233

目次

頁

ベッド、カバー、クランクシャフト機構.....	2- 3
送り機構	4- 5
押エ機構	6- 7
ゲージパーツ表	8- 9
部品番号インデックス	10

TABLE OF CONTENTS

Page

MACHINE BED FRAME,COVER,CRANKSHAFT DRIVE MECHANISM	2- 3
FEED MECHANISM.....	4- 5
PRESSER FOOT MECHANISM	6- 7
GAUGE PARTS LIST.....	8- 9
PART NUMBER INDEX.....	10

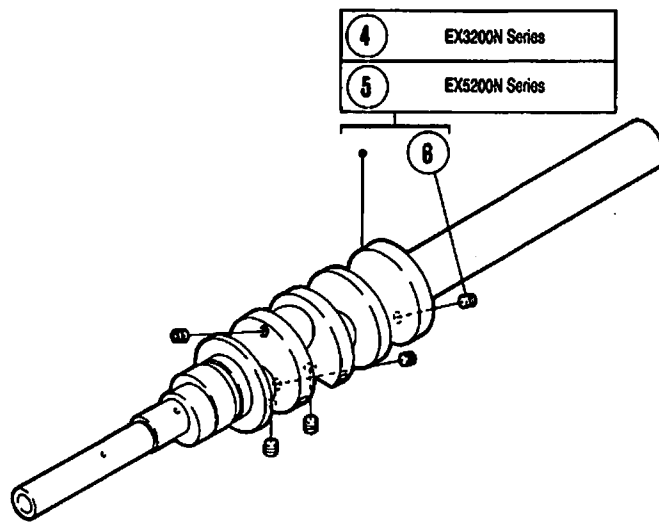
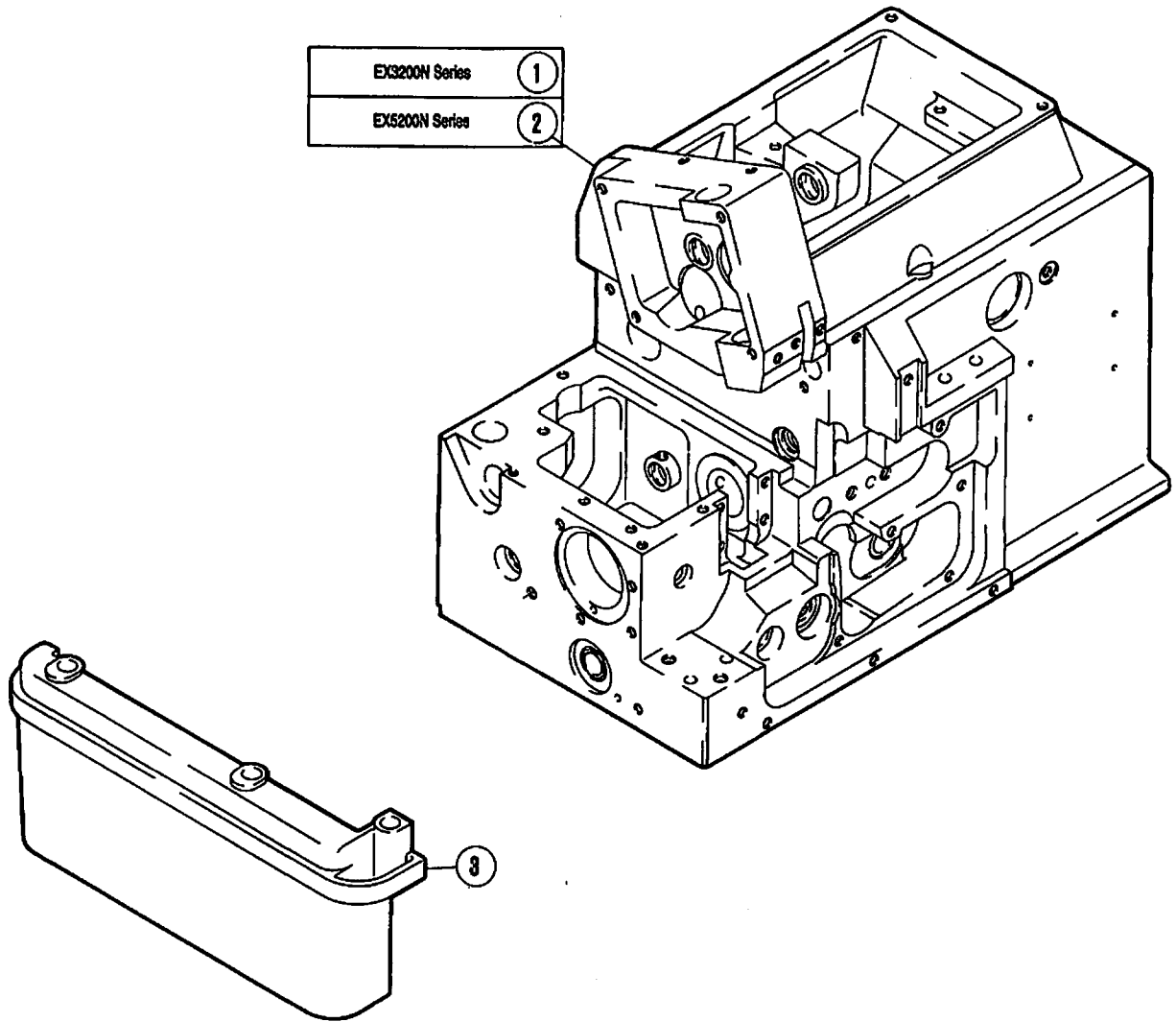

ベッド,カバー
クランクシャフト機構

MACHINE BED FRAME ,COVER
CRANKSHAFT DRIVE MECHANISM

REF. NO.	PART NO. 部品番号	名称	NAME	QT.
*1	270001D9S	ベッド (組)	MACHINE BED COMPLETE	01
*2	270001C9S	ベッド (組)	MACHINE BED COMPLETE	01
3	270030DUB	横カバー	SIDE COVER	01
4	270500F	クランク軸	CRANKSHAFT	01
5	270500E	クランク軸	CRANKSHAFT	01
6	007151	止ネジ	SCREW	05

●*＝販売不可
●XXXXXXはゲージパーツです。
8-9頁のゲージパーツ表で確認してください。

●*＝ Not for sale basically
●XXXXXX is one of the gauge parts.
Please confirm the correct part by the gauge parts lists on pages 8-9.

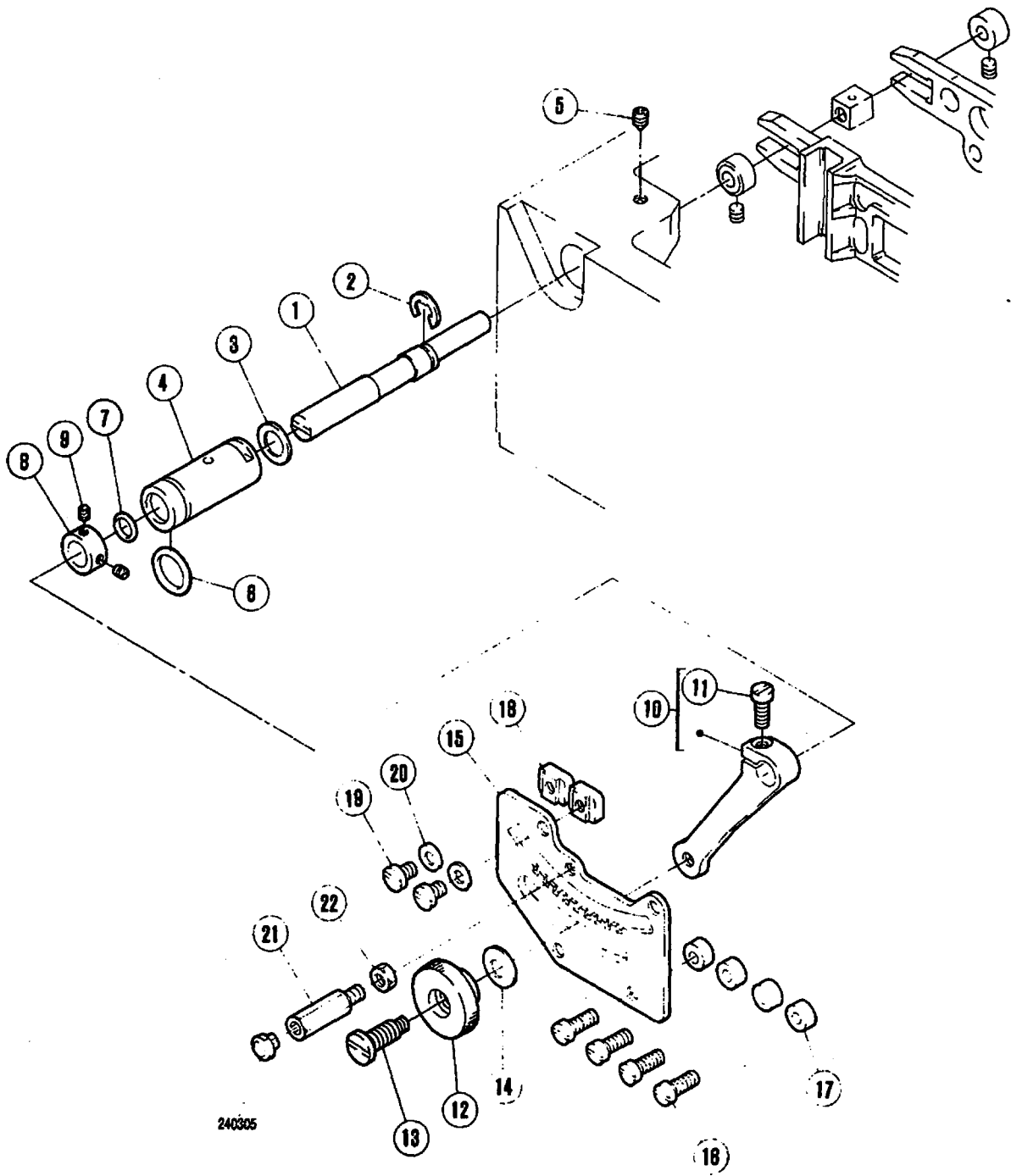

送り機構

FEED MECHANISM

REF. NO.	PART NO. 部品番号	名称	NAME	QT.
1	272554	段付ピン	PIN	01
2	202522	止メ輪	RING	01
3	240434	座金	WASHER	01
4	272553	ブッシュ	BUSHING	01
5	004546	止ネジ / M4 × 5	SCREW	01
6	201022	Oリング	O RING	01
7	240017	Oリング	O RING	01
8	232508	カラー	COLLAR	01
9	001459	止ネジ / C4 × 3	SCREW	02
10	272555-92	レバー	LEVER	01
11	007014	平ネジ / M3.5 × 10	SCREW	01
12	252069	ナット	NUT	01
13	007059	段付ネジ / 4.5	SCREW	01
14	211301	皿バネ	SPRING	01
15	272556	調節板	REGULATING PLATE	01
16	007021	平小ネジ / M4 × 12	SCREW	04
17	240321	スペーサー	SPACER	04
18	252658	ストッパー	STOPPER	02
19	007018	平ネジ / M4 × 6	SCREW	02
20	303448	座金	WASHER	02
21	270076B	ホルダー	HOLDER	01
22	004821	六角ナット / M4	NUT	01

●*＝販売不可
●XXXXXXはゲージパーツです。
8-9頁のゲージパーツ表で確認してください。

●*＝ Not for sale basically
●XXXXXX is one of the gauge parts.
Please confirm the correct part by the gauge parts lists on pages 8-9.

EX3215N•EX3216N-01

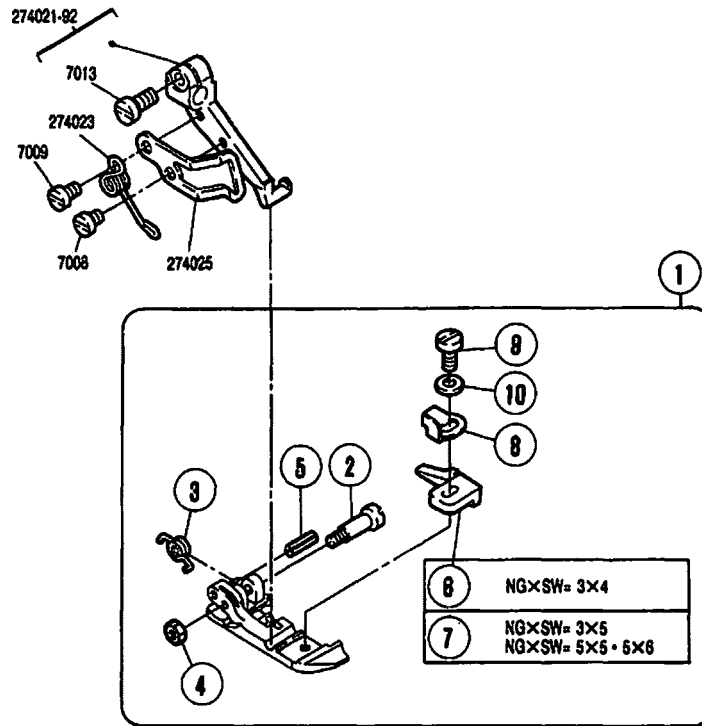

EX5204N•EX5214N-01

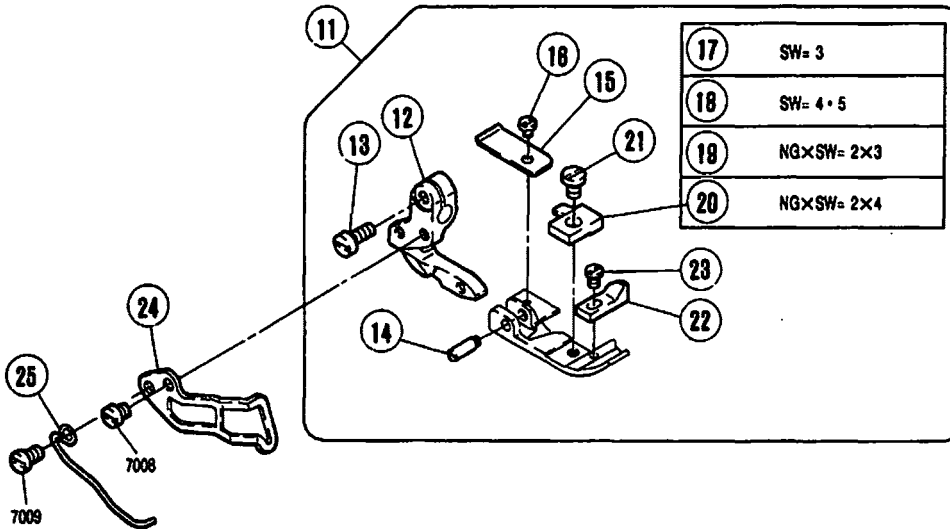

REF. NO.	PART NO. 部品番号	名称	NAME	QT.
1	XXXXXX	押エ	PRESSER FOOT	01
2	211919	段付ピン	PIN	01
3	211918	ネジリバネ	SPRING	01
4	003150	六角ナット / C1	NUT	01
5	211920	スプリングピン	PIN	01
6	211915A	押エ爪	PRESSER FOOT FINGER	01
7	211916A	押エ爪	PRESSER FOOT FINGER	01
8	211917	取付板	BRACKET	01
9	005089	平ネジ	SCREW	01
10	300248	座金	WASHER	01
11	XXXXXX	押エ	PRESSER FOOT	01
*12	277136	ホルダー	HOLDER	01
13	007013	平小ネジ / M3.5 × 8	SCREW	01
14	212059-B	ヒンジピン	PIN	01
15	212668	補助板	AUXILIARY PLATE	01
16	005030	平ネジ / C1 × 2.3	SCREW	01
17	210370	押エ爪	PRESSER FOOT FINGER	01
18	210371	押エ爪	PRESSER FOOT FINGER	01
19	201396B	押エ爪	PRESSER FOOT FINGER	01
20	201310A	押エ爪	PRESSER FOOT FINGER	01
21	001229	平ネジ / C3 × 4.5	SCREW	01
22	211557	補助押エ	FABRIC GUARD	01
23	001231	平ネジ / C1 × 3.4	SCREW	01
24	274064	フィンガーガード	FINGER GUARD	01
25	274063	ネジリバネ	SPRING	01

●*ニ販売不可

●XXXXXXはゲージパーツです。

168-181頁のゲージパーツ表で確認してください。

●*ニ Not for sale basically

●XXXXXX is one of the gauge parts.

Please confirm the correct part by the gauge parts lists on pages8-9.

形式 MACHINE TYPE /SPEC.	ゲージ GAUGE		針板 NEEDLE PLATE	主送り歯(組) MAIN FEED DOG ASS.	主送り歯本体 MAIN FEED DOG	補助送り歯 AUX. FEED DOG	差動送り歯 DIFF. FEED DOG	押エ(組) PRESSER FOOT ASS.	上ルーバー UPPER LOOPER	上スプレッダー UPPER SPREADER	下ルーバー LOWER LOOPER	二重縫ルーバー CHAINSTITCH LOOPER
	NG	SW										
(15) EX3216N-01/222	3	4	277583P40	277376-13	(277377-13)	(277318B13)	277325-13	211809B	277010 # 2	277014A # 8	277015	277018
		5	" 50					211810B				
(15) EX3216N-01/232	3	4	277581P40	277374-13	(277375-13)	(277318B13)	277330-13	277188	277010 # 2	277014A # 8	277015	277018
		5	" 50					277187				
	5	5	277582P50				277320-13	277188				
		6	" 60									

形式 MACHINE TYPE /SPEC.	ゲージ GAUGE		上メス UPPER KNIFE		下メス LOWER KNIFE	オーバー針受 OVERLOCK NEEDLE GUARD		二重縫針受 CHAINSTITCH NEEDLE GUARD		針留 NEEDLE HOLDER	針留糸道 THREAD GUIDE (NDL HOLDER)	針 NEEDLE
	NG	SW	平メス	角メス		前	後	前	後			
			FLAT KNIFE	ANGLED KNIFE		FRONT	REAR	FRONT	REAR			
(15) EX3216N-01/222	3	4	202527A	—	202285	277007	277004	277008	277008	277027-82	275030	DC X 27 # 11
		5										
(15) EX3216N-01/232	3	4	202527A	—	202285	277007	277004	277008	277008	277027-82	275030	DC X 27 # 11
		5										
	5	5								277028-82		
		6										

形式 MACHINE TYPE /SPEC.	ゲージ GAUGE		針板 NEEDLE PLATE	主送り歯(組) MAIN FEED DOG ASS.	主送り歯本体 MAIN FEED DOG	補助送り歯 AUX. FEED DOG	差動送り歯 DIFF. FEED DOG	押エ(組) PRESSER FOOT ASS.	上ルーバー UPPER LOOPER	下ルーバー LOWER LOOPER		
	NG	SW										
EX5204N-01/232(K)	-	3	277559P30	277372-16F	(277304B16F)	(277318B13)	277305-16F	277214	277010 #2	277015		
		4	" 40					277215				
		5	" 50									
EX5214N-01/262(K)	2	3	277560P30	277372-16F	(277304B16F)	(277318B13)	277373-16F	277216	277010B #6	277015		
		4	" 40					277217				

形式 MACHINE TYPE /SPEC.	ゲージ GAUGE		上メス UPPER KNIFE		下メス LOWER KNIFE	針受 NEEDLE GUARD		針留 NEEDLE HOLDER	針留糸道 THREAD GUIDE (NDL HOLDER)	針 NEEDLE		
	NG	SW	平メス FLAT KNIFE	角メス ANGLED KNIFE		前 FRONT	後 REAR					
			EX5204N-01/232(K)	-	3	201121A	210755	201127	277005	277004	179830-82	275019A
4	202285											
5												
EX5214N-01/262(K)	2	3	201121A	210755	201127	277005	277004	277022-82	275019B	DC X 27 # 9		
		4			202285							

INDEX

PART NO.	PAGE	NO. REF.	PART NO.	PAGE	NO. REF.	PART NO.	PAGE	NO. REF.	PART NO.	PAGE	NO. REF.	PART NO.	PAGE	NO. REF.
1229	7	21	277875-18	8	10									
1231	7	28	277876-18	8	7									
1469	5	9	277877-18	8	9									
3150	7	4	277559P30	9	1									
4548	5	5	277559P40	9	2									
4821	5	22	277559P50	9	8									
5080	7	18	277580P30	9	4									
5089	7	9	277580P40	9	5									
7013	7	13	277581P40	8	8									
7014	5	11	277581P50	8	4									
7018	5	18	277582P50	8	5									
7021	5	18	277582P80	8	8									
7059	5	13	277583P40	8	1									
7151	3	8	277583P50	8	2									
179680-82	9	20	809248	7	10									
201022	5	6	808448	5	20									
201121A	9	15												
201127	9	17												
201810A	7	20												
201896B	7	19												
202295	8	25												
202522	5	2												
202527A	8	24												
210370	7	17												
210371	7	18												
210756	9	16												
211301	5	14												
211557	7	22												
211909B	8	15												
211910B	8	16												
211915A	7	8												
211916A	7	7												
211917	7	8												
211918	7	3												
211919	7	2												
211920-B	7	5												
212050-B	7	14												
212068	7	15												
232508	5	8												
240017	5	7												
240321	5	17												
240434	5	8												
252089	5	12												
252058	5	18												
270001C9S	8	2												
270001D9S	3	1												
270030DUB	8	3												
270076B	5	21												
270500E	3	5												
270500F	3	4												
272553	5	4												
272554	5	1												
272555-92	5	10												
272555	5	15												
274063	7	25												
274064	7	24												
275019A	9	22												
275019B	9	23												
275030	8	32												
277004	8	27												
277004	9	19												
277005	9	18												
277006	8	29												
277007	8	26												
277008	8	28												
277010#2	8	20												
277010B#8	9	14												
277014A#8	8	21												
277015	8	22												
277016	8	23												
277022-92	9	21												
277027-92	8	30												
277028-92	8	31												
277186	7	12												
277186	8	17												
277187	8	16												
277188	8	19												
277214	9	10												
277215	9	11												
277218	9	12												
277217	9	13												
277804D16F	9	7												
277805-16F	9	8												
277818B18	8	11												
277825-18	8	12												
277829-18	8	14												
277830-18	8	13												
277872-16F	9	6												
277873-16F	9	9												
277874-18	8	8												