

**AMF REECE**

*Better Ideas, Better Made*

**SERIES 101**

**EYELET BUTTONHOLE MACHINE**

**PARTS & SERVICE MANUAL**

**PART NUMBER 97.0101.01**

1917-1918  
Sewing Machine & Supply Co.

2

1917-1918

Sewing Machine & Supply Co.

2

Sewing Machine & Supply Co.

Sewing Machine & Supply Co.

2



## LIMITED WARRANTY ON NEW AND RECONDITIONED EQUIPMENT

### **What is covered:**

90 day limited warranty on service labor due to defects in workmanship or materials.

1 year on major component parts due to defects in materials. Any new or reconditioned part which a customer feels is defective, must be returned freight prepaid to AMF Reece, Inc. for inspection. If, upon inspection the part is determined to be defective, AMF Reece, Inc. will replace it at no charge to the customer.

Warranty period shall begin on completed installation date.

### **What is not covered:**

Consumable parts which would be considered normally replaceable in day to day operations.

Normal adjustment and routine maintenance will not be covered. This is the sole responsibility of the customer.

From the library of Superior Sewing Machine & Supply LLC - [www.supsew.com](http://www.supsew.com)



# CONTENTS

	SHEET NO.
SET-UP INSTRUCTIONS .....	1
<b>THREADING DIAGRAMS</b>	
For All Series 101 Machines, Except Cord Trim .....	2-3
For All Series 101 Cord Trim Machines .....	21
OPERATING INSTRUCTIONS .....	4-5
<b>MACHINE ADJUSTMENTS</b>	
Common to All Series 101 Machines .....	6-17
(a) Effecting Character of Buttonhole .....	6-8
(b) Corrective and Maintenance .....	9-17
Adjustments Pertaining Specifically to:	
(a) Cut Before Buttonhole Machines .....	18-20
(b) Cut Before Edging Machines .....	27
(c) Cord Trim Machines .....	22-24
(d) Adjustable Fly Bar Machines .....	25-26
NEEDLE INFORMATION .....	28
TROUBLE DIGEST	PAGES 1-11

# STITCHES

1. Straight stitch  
2. Zigzag stitch  
3. Darning stitch  
4. Blind stitch  
5. Hemming stitch  
6. Buttonhole stitch  
7. Overlock stitch  
8. Rolled hem stitch  
9. Elastic stitch  
10. Gathering stitch  
11. Applique stitch  
12. Quilting stitch  
13. Topstitch  
14. Basting stitch  
15. Catch stitch  
16. Ladder stitch  
17. Slip stitch  
18. Topstitch  
19. Blind hem  
20. Overlock

## STOP MOTION ADJUSTMENTS

101 Stop Position — all 101 models except the Eyelet and Cross Oval — when the head of the machine is all the way forward.

1) Page 14, Figures 5 and 6 — Machine in stop position and the stitch wheel locked up. Check Roll 10-1122-0-000 (G) on the 10-1120-0-000 Link. It should rest lightly on the 10-2018-1 (H) Length Gauge. Adjust by turning Adjustment Screw 10-2066 (J) on Bracket 10-1127-3-000.

2) Page 15, Figure 1-A — Machine in stop position — locked up. Roll 01-7002 (C) should lightly contact the low point of the cam on the inside of the Hand Wheel 10-1088-0-050. Adjust by loosening screw 10-1114-0-000 (E) on Three Forked Lever 10-1113-0-000 (F). Recheck adjustment number 1.

3) Page 16, Figures 4 and 5 — While holding turning pressure on the Hand Wheel, 10-1088-0-050, crank the machine back by using the Cutting Wheel 10-3039-0-000 instead of the Crank 10-3037-1. (On Cut Before machines, use the crank until after cutting or remove cutting steel.) The 10-1089-0-000 Dog (J) on the 10-1088-0-000 Hand Wheel should disengage the 10-1099-0-000 Bolt (Q) on the Rocking Lever as the 10-3038-1 Striker (R) on the crank disengages the 10-3042-2 Dog (S) on the cutting wheel. Adjust by loosening Clamp Screw 01-2035-0-000 (T) on Shifter Spool 10-3045-0-000 and moving in or out to suit.

4) Page 15, Figure 3-A — Crank the machine back until the 10-1122-0-000 Roll (G) is on the high point of the 10-2018 Length Gauge (H). In this position, the 10-1085-0-000 Lever should be approximately  $1/16''$  from the 10-1102-0-000 Dog (not shown). Adjust by loosening nut 10-3005 and positioning. Set the rise and fall of the 10-1085 Lever so that its lowest point is approximately  $1/16''$  below the top of the 10-1102-0-000 Dog. Adjust by positioning 10-1087-0-000 Bracket.

Check 10-1124 Lever (K) for correct clearance of Dog on the Three Forked Lever (10-1113-0-000) — (F) by lifting 10-1118-0-000 Lever, which releases the 10-1120-0-000 Roll (G) and lets the 10-1124-0-000 (K) take over. The 10-1102-1-000 should not move more than  $2/3$  of the distance to 10-1085-0-000. Adjust 10-1124-0-000 to suit.

5 & 6) Page 17, Figure 1.

5) Stop position  $1/64''$  between points (E and F).

6) Crank machine through cycle until 10-3039-0-000 Cutting Wheel (Fig. 1) shifts part way out as Lever K (10-1124-0-000, Fig. 3-A, Page 15) is released. When one stitch more is taken by turning the hand wheel, the cutting wheel shifts all the way out and the hand wheel is locked up. Contact points at (E and F) should just clear when the cutting wheel moves out. If hitting, adjust wheel inward by loosening screw (T), Figure 5, Page 16 and tapping wheel. Recheck adjustment #3. If compensation between these two adjustments is not possible, the lower prong of the Three Forked Lever has to be bent (removed from machine).

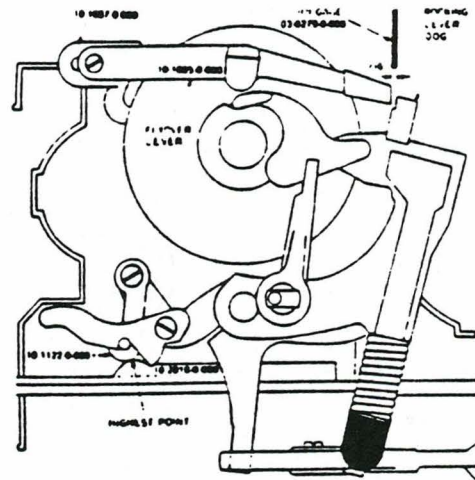

# INSTRUCTIONS FOR INSTALLATION ON REECE INDIVIDUAL TABLES

Parts and Belting for this installation are contained in the accessory box which accompanies each machine.

1. Be certain that Motor Pulley (A) rotates in direction of arrow. If not, motor rotation must be corrected before operating machine.

2. Check with a plumb line to see that the heel of Transmitter Pedal is 6" in back of front edge of the table.

3. Place the Machine on the Table between the belt slots and even with front edge of Table. Install crossed Belt (B) and open Belt (C). The rear leg of Belt (C) must pass between the Idle Pulley (D) and Belt Guard (G).

4. Adjust Machine sideways as necessary so that Belt (C) is central in its belt slot, and attach Machine to Table with 4 wood screws.

5. Crank the Machine head to the rearmost point of its travel and adjust Idle Pulley (D), to provide approximately 1/4" clearance between Belt Guard (G) and the front leg of Belt (C).

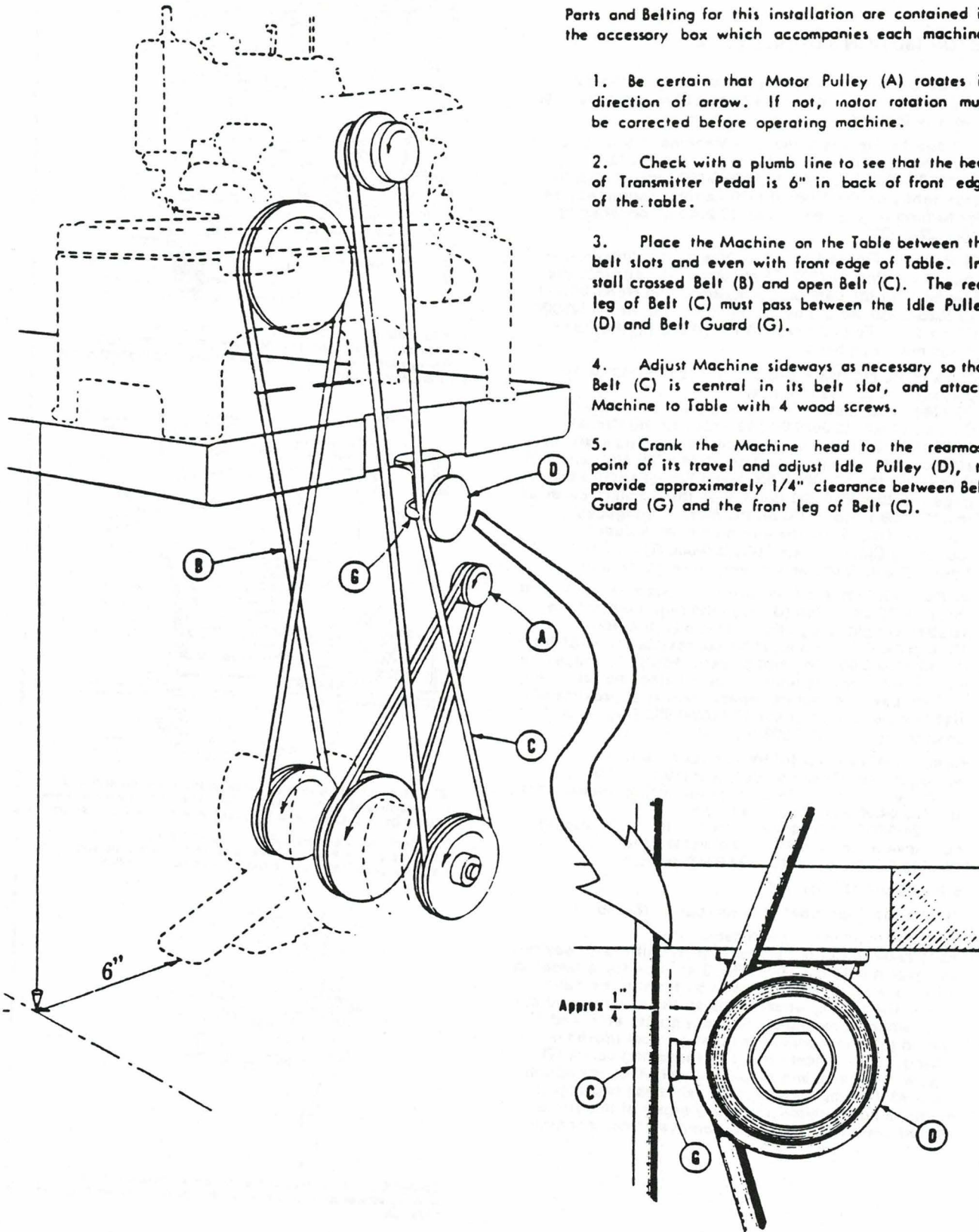

## MODEL 101 - SETTING UP INSTRUCTIONS

Before operating the machine by hand or power, remove the two shipping pins shown Fig. 1, which are easily identified by a red tag tied to each - these pins are installed at the factory to lock the Head and Bed Plate together as a protection against shipping damages.

Set up machine in accordance with the instructions on the installation template that is sent with each new machine. This template shows two different installations depending on direction of rotation of the power shaft. The one marked "Preferred Installation" on which the left hand machine belt is crossed and the right hand one open, should always be employed when the machine is installed on a Reece Individual Motorized Table. The "Preferred Installation" should also be used whenever possible in cases where the machine is installed on a line shaft table.

In the event that the machine should be disassembled at any time, the correct line-up of the Head on the Bed Plate can be re-established by using one of the shipping pins in the following manner:

Turn the left hand crank handle until shipping pin hole (A) Fig. 2 in the Head corresponds with shipping pin hole (B) in Bed Plate. If holes (A) and (B) do not line up exactly, loosen clamp screw (E) Fig. 2 and move the Head of machine to left or right until holes (A) and (B) line up when tested with the shipping pin.

If no shipping pin is available, proceed as outlined above, but match line (C) on Head with line (D) on Bed Plate as illustrated Fig. 2.

**IMPORTANT** - Before tightening clamp screw (E), press lever 1-C19 upward on the stud to lightly contact the shoulder of the Cam Case.

**NOTE:** - Do not follow these line-up instructions on Adjustable Fly Bar machines. Use the instructions on Sheet 26.

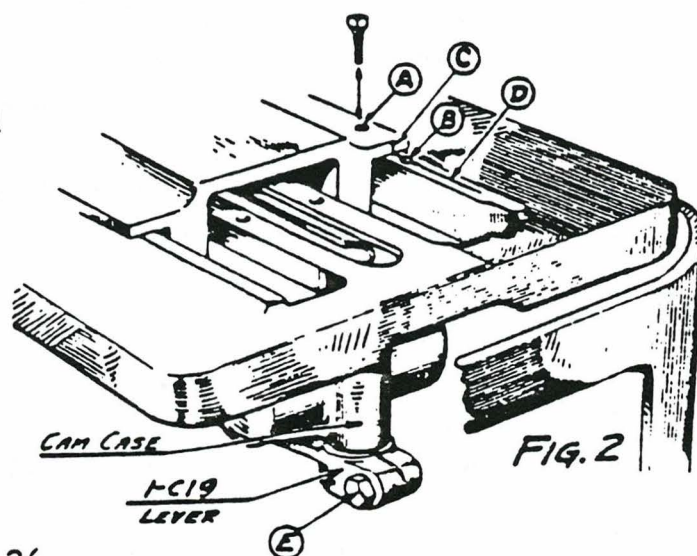
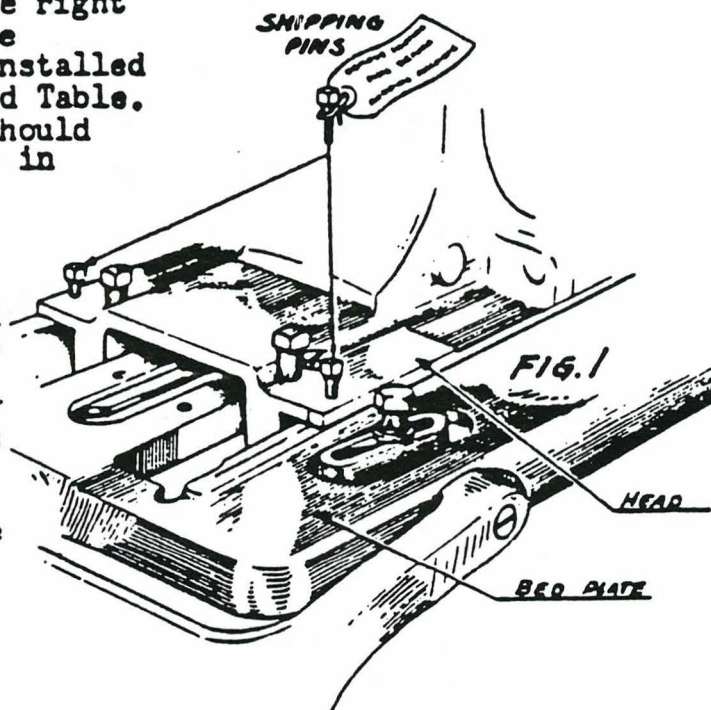

**AMF REECE**

- THREADING DIAGRAMS -

UPPER SYSTEM

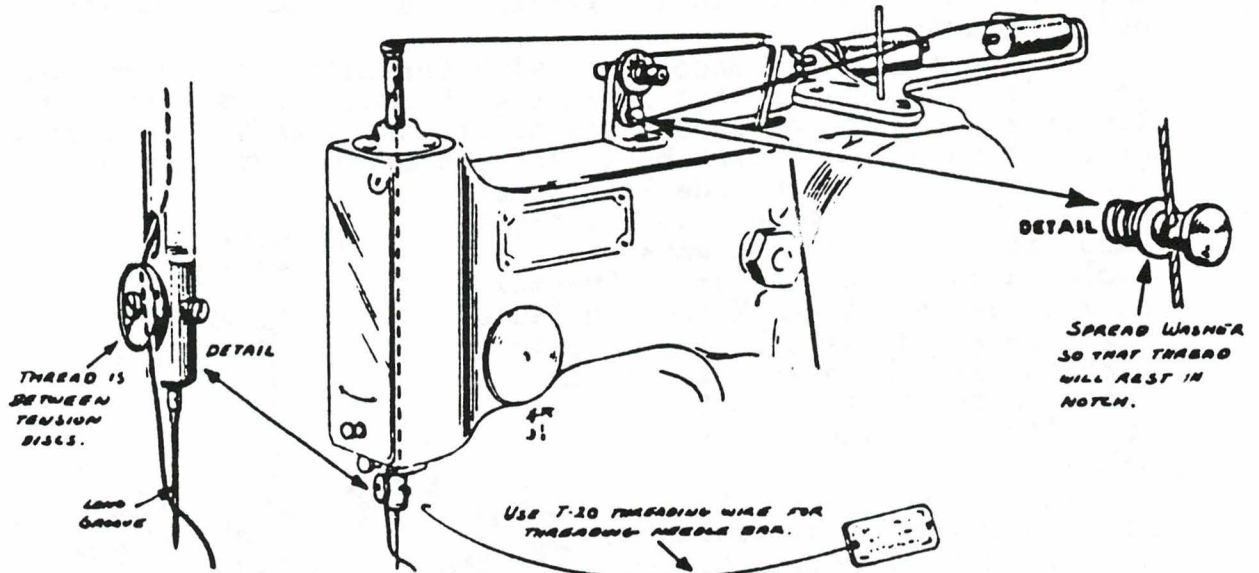

- THREADING OF FIXED TYPE TENSIONS -

SPLIT DISC TYPE

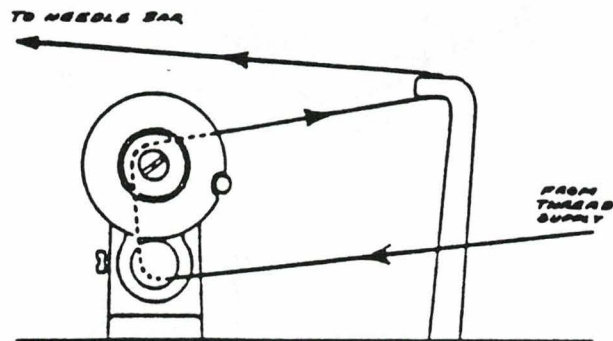

SOLID ROLLER TYPE

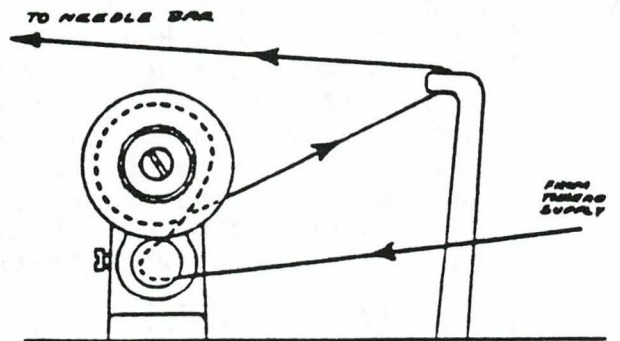

NOTE: THREAD MAKES APPROXIMATELY ONE FULL TURN AROUND THE ROLLER ON THIS TENSION.

- THREADING OF ROCKING TYPE TENSIONS -

SPLIT DISC TYPE

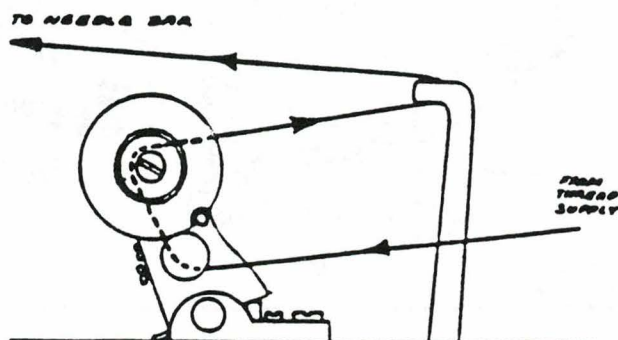

SOLID ROLLER TYPE

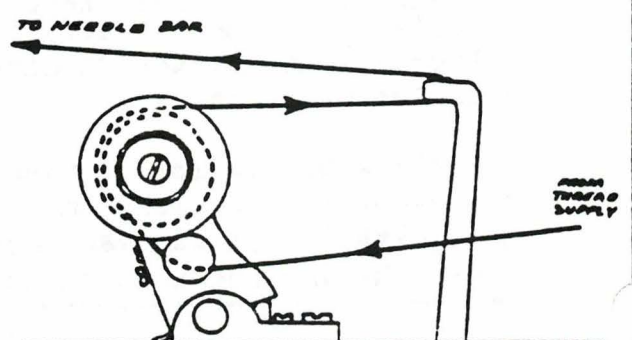

NOTE: THREAD MAKES APPROXIMATELY 1 1/2 TURNS AROUND THE ROLLER ON THIS TENSION.

NOTE: REFER TO SHEET 21 FOR ADDITIONAL INFORMATION ON THREADING CORD TRIM MACHINES.

- THREADING DIAGRAMS -  
LOWER SYSTEM

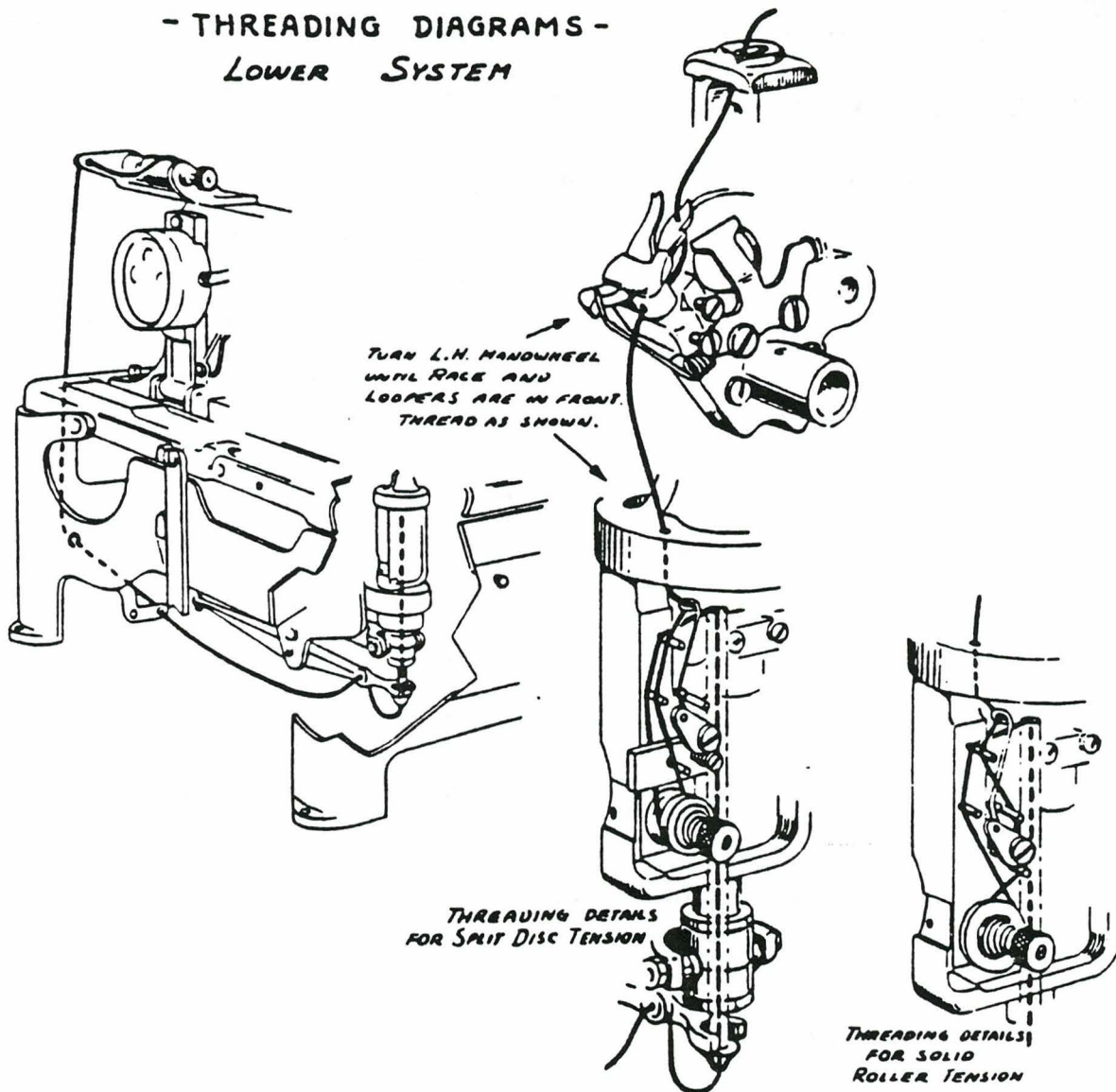

CORD THREADING  
DIAGRAM

CRANK MACHINE UNTIL  
RACE FACES AS SHOWN.

NOTE:

CORD MAY ALSO BE  
LED FROM REAR OF  
MACHINE THROUGH GUIDE  
A, AND UP THROUGH THE  
RACE AND THROAT PLATE  
AS SHOWN.

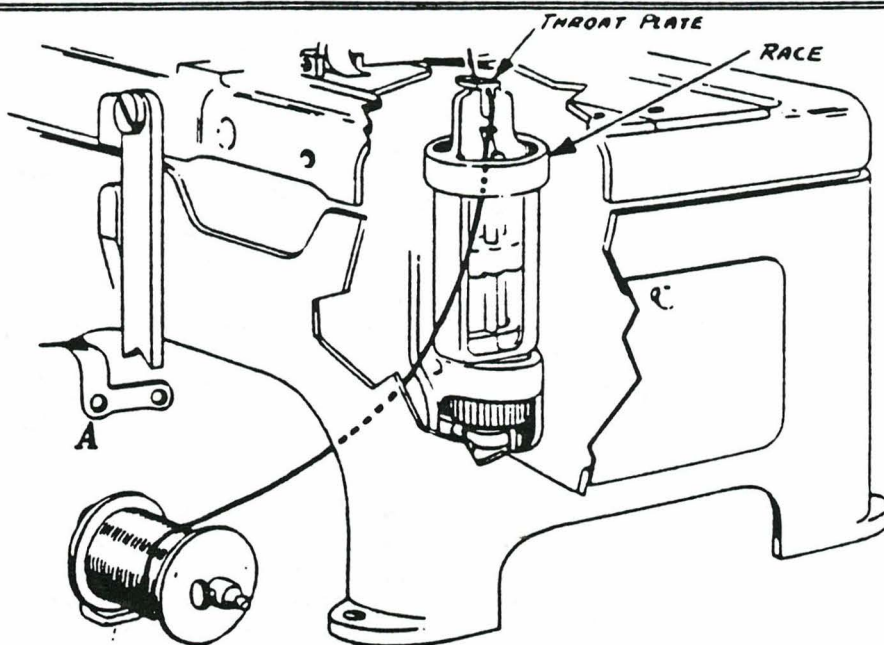

NOTE: REFER TO SHEET 21 FOR THREADING DIAGRAMS  
ON CORD TRIM MACHINES.

# MODEL-101 OPERATING INSTRUCTIONS

- ① REMOVE THE NEEDLE AND TEST IT FOR STRAIGHTNESS; INSERT AS BELOW.

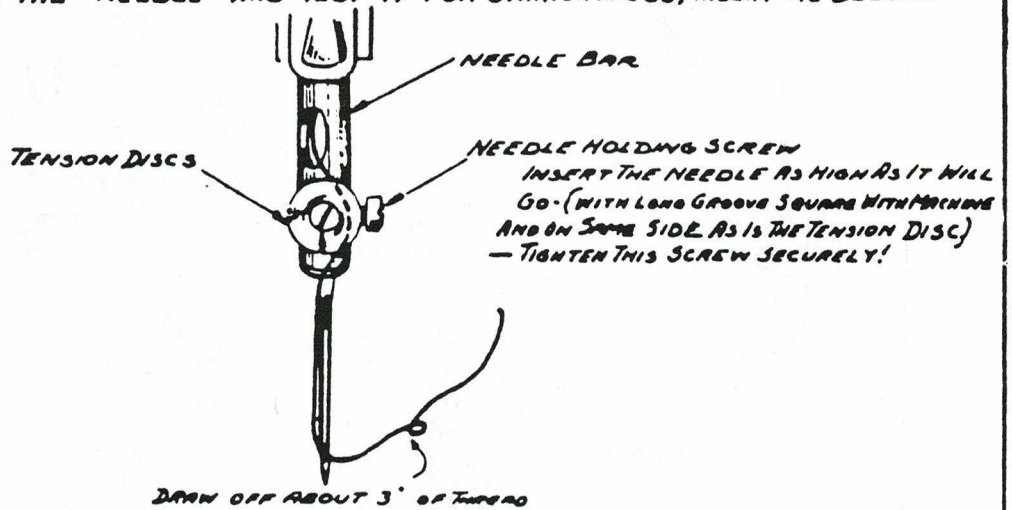

- ② PUT ON THE BELTS  
**CAUTION - BEFORE POWER IS APPLIED WITH FOOT TREADLE - SEE THAT NEEDLE BAR IS AT ITS HIGHEST POINT - LOCKED; AND MACHINE AT ITS MOST FORWARD POSITION**
- ③ DEPRESS THE TREADLE ON TRANSMITTER TO START BELTS.
- ④ INSERT WORK UNDER THE CLAMP ARMS AND FEET

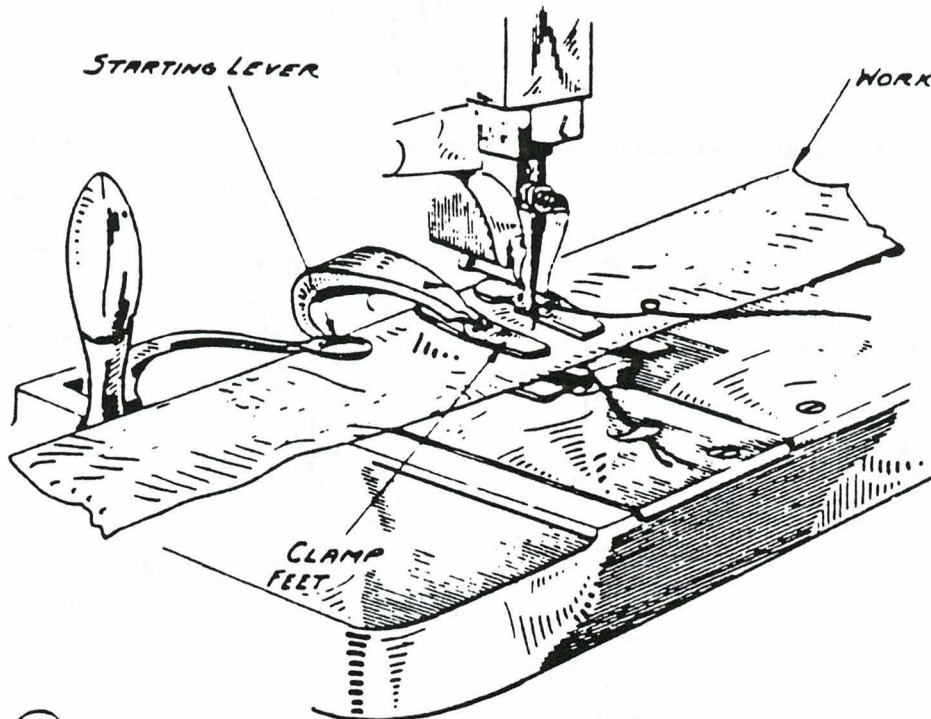

- ⑤ DEPRESSION OF THE STARTING LEVER WILL COMPLETE ONE BUTTON HOLE AND AUTOMATICALLY RELEASE WORK AND STOP.

## MODEL-101 - OPERATING INSTRUCTIONS

PROVISION IS MADE ON THIS MACHINE TO MEET ANY EMERGENCY ARISING DURING THE MAKING OF THE BUTTON HOLE.

TO EXTRACT WORK IN CASE OF UNTHREADING OR MISLOCATION.

PROCEED AS FOLLOWS-

- ① PRESS PEDAL ON TRANSMITTER TO STOP BELTS.
- ② PULL LEVER (A) IN DIRECTION OF ARROW TOWARD OPERATOR.
- ③ TURN R.H. HAND WHEEL (KNURLED RIM) IN DIRECTION OF ARROW UNTIL LOCKED.
- ④ MOVE CLAMP LEVER (C) AWAY FROM OPERATOR TO RELEASE WORK - AND WITHDRAW IT.

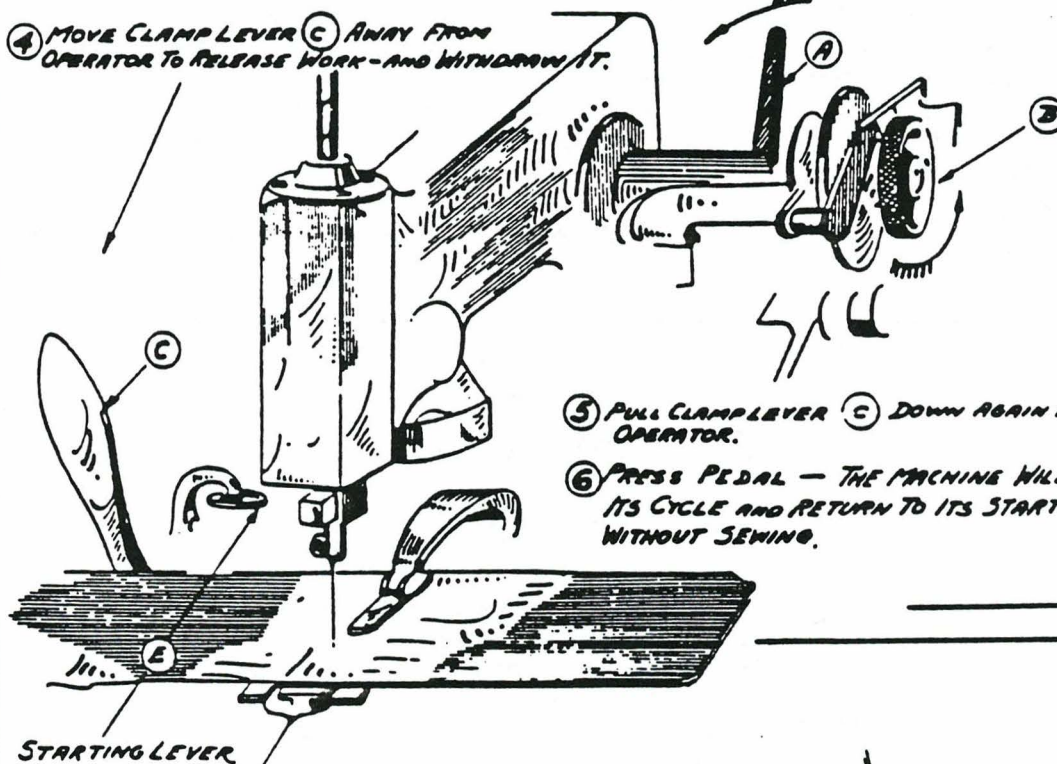

- ⑤ PULL CLAMP LEVER (C) DOWN AGAIN IN DIRECTION OF OPERATOR.
- ⑥ PRESS PEDAL - THE MACHINE WILL NOW COMPLETE ITS CYCLE AND RETURN TO ITS STARTING POSITION WITHOUT SEWING.

A COMPLETE CYCLE UNDER POWER, INCLUDING THE CUTTING OPERATION - MAY BE MADE WITHOUT SEWING.

LIFT UP THE LEVER (D) AND HOLD - DEPRESS THE STARTING LEVER (E) AND LET GO OF LEVER (D) AFTER THE MACHINE HAS TRAVELLED A SHORT DISTANCE - THE MACHINE WILL THEREAFTER COMPLETE ITS CYCLE AND CUT FABRIC WITHOUT STITCHING. IT CAN BE STOPPED IN ANY DESIRED POSITION WITH THE TRANSMITTER PEDAL.

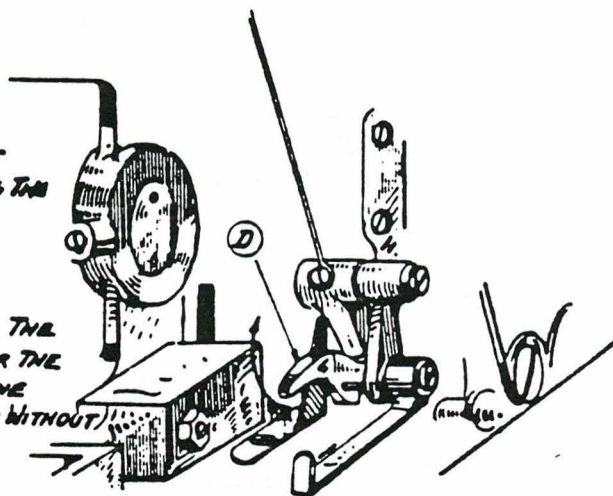

**MODEL-101 ADJUSTMENTS THAT DETERMINE THE CHARACTER OF THE BUTTON HOLE.**

**NEEDLE INFORMATION**

NEEDLES FOR THE SERIES 101 MACHINE ARE AVAILABLE IN A WIDE RANGE OF SIZES AND TYPES AS LISTED ON SHEET 28.

AS A GENERAL RULE IT IS DESIRABLE TO USE NEEDLES WITH THE FINEST BLADE THAT THE THREAD AND MATERIAL WILL ALLOW.

ON CUT BEFORE MACHINES IT IS PARTICULARLY IMPORTANT TO USE FINE, ROUND POINTED NEEDLES IN THE PLAIN OR SPOTTED TYPES.

ON CUT AFTER MACHINES FOR ALL AVERAGE GRADES OF FABRICS, STANDARD ROUND POINT SPOTTED OR BALL EYE NEEDLES ARE RECOMMENDED.

**NOTE-** FOR DETAILED NEEDLE INFORMATION REFER TO SHEET 28.

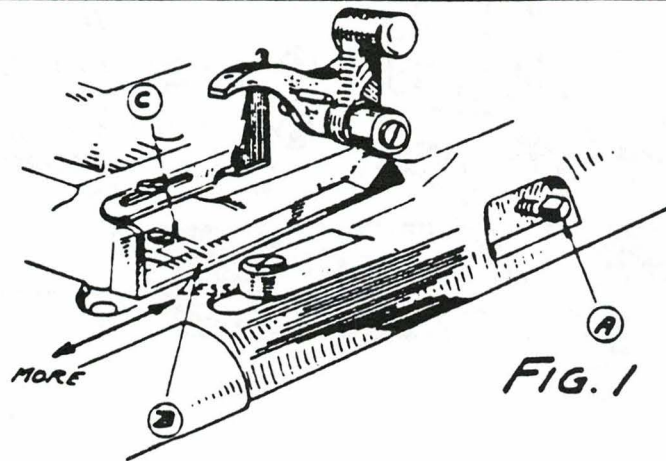

FIG. 1

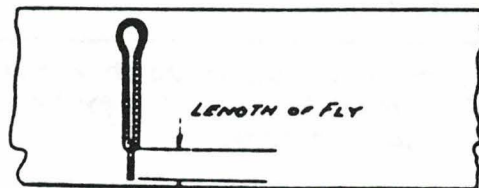
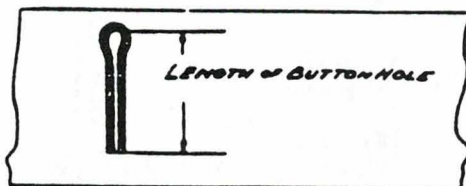

FIG. 2

**TO ADJUST THE LENGTH OF BUTTON HOLE**

LOOSEN SET SCREW (A) AND PULL GAUGE (B) FORWARD FOR LONGER BUTTON HOLE.  
PUSH LEVER TO THE REAR FOR SHORTER BUTTON HOLE.

**NOTE**

ON FLY BAR MACHINES THE SAME ADJUSTMENT WILL LENGTHEN OR SHORTEN THE FLY BAR OR DO AWAY WITH THE BAR ENTIRELY.

**MODEL-101-ADJUSTMENTS THAT DETERMINE THE CHARACTER OF THE BUTTON HOLE.**  
 - CONTINUED -

**ADJUSTING THE BITE AND CUTTING SPACE**

'BITE' IS THE DISTANCE BETWEEN THE TWO POINTS OF ENTRY OF THE NEEDLE INTO THE FABRIC AS IT DESCENDS TO MAKE THE STITCH

- CHARACTER OF MATERIAL DETERMINES THE WIDTH OF BITE.

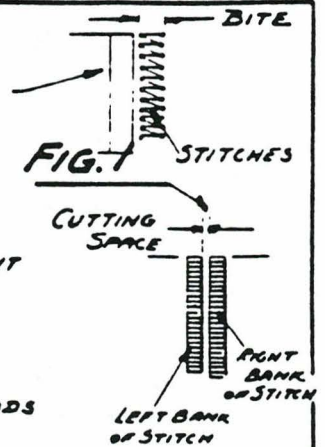

'CUTTING SPACE' IS THE SPACE BETWEEN THE LEFT AND RIGHT BANK OF STITCHES INTO WHICH THE CUTTING KNIFE DESCENDS TO CUT THE MATERIAL.

THE IDEAL WIDTH OF THIS SPACE DEPENDS UPON NEATNESS REQUIRED AND CHARACTER OF MATERIAL.

THIN FABRICS REQUIRE BUT LITTLE - THICK GOODS MORE - THE RANGE IS FROM 0" TO 1/4"

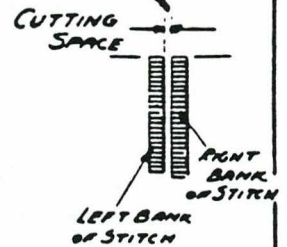

TO ADJUST THE WIDTH OF BITE - LOOSEN NUT (A) AND MOVE THE LINK (B) UP OR DOWN IN DIRECTION OF ARROW TO SUIT.

MOVING THIS LINK (B) UPWARD WILL NARROW THE WIDTH OF BITE - DOWNWARD WILL WIDEN IT.

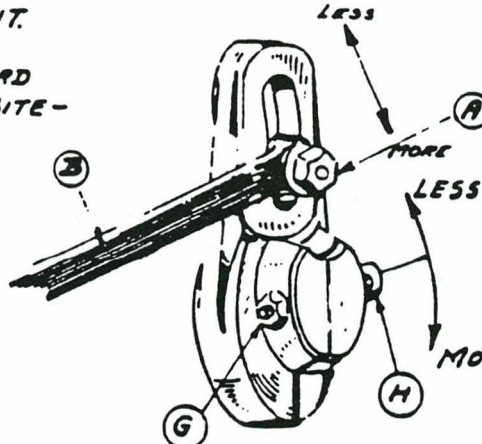

TO ADJUST THE WIDTH OF CUTTING SPACE - LOOSEN SCREW (H) AND WITH PIN WRENCH BODILY MOVE THE SCREW HEAD (M) TO SUIT.

NOTE ON CUT BEFORE MACHINES THIS ADJUSTMENT SHOULD BE MADE SO THAT THE INSIDE STROKE OF THE NEEDLE WILL BE IN CENTER OF THE BUTTON HOLE SLIT

**TO ADJUST THE CLAMP SPREAD**

VARIOUS KINDS OF MATERIAL REQUIRE MORE OR LESS SPREADING OF GOODS BETWEEN THE CLAMPS.

TO VARY THIS SPREAD OR TO EQUALIZE IT - USE ADJUSTMENT SHOWN IN FIG. 4 AND BELOW

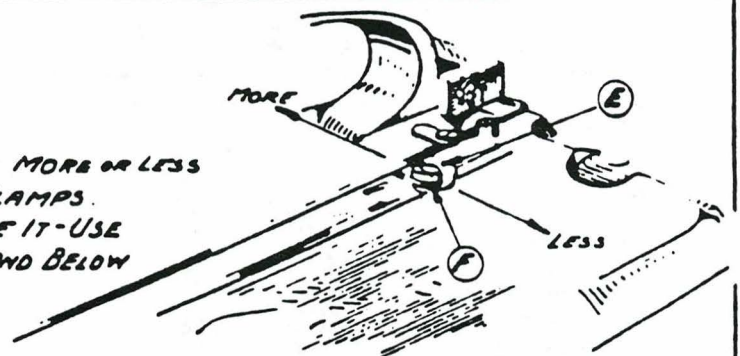

LOOSEN SCREW (F) ON EACH SIDE OF THE MACHINE AND MOVE ADJUSTING SLIDES INWARD FOR MORE SPREAD - AND OUTWARD FOR LESS.

NOTE - BE SURE THAT ONE SIDE IS NOT SPREADING MORE THAN THE OTHER.

**MODEL-101 - ADJUSTMENTS THAT DETERMINE THE CHARACTER OF THE BUTTON HOLE**  
 - CONTINUED -

**ADJUSTING THE NUMBER OF STITCHES PER INCH IN A BUTTON HOLE.**

DENSITY OF STITCHES OR NUMBER OF STITCHES PER INCH

LOOSEN NUT (E) AND MOVE LEVER ASSEMBLY (F) IN SLOT (G); IN EITHER DIRECTION TO SUIT.

MOVEMENT IN DIRECTION OF REAR OF MACHINE WILL DECREASE THE NUMBER OF STITCHES. MOVEMENT TOWARD THE FRONT WILL INCREASE THE NUMBER.

LESS

MORE

FIG. 1

**INCREASING OR DECREASING THE NUMBER OF STITCHES IN THE EYE INDEPENDENTLY OF THE SIDES**

DENSITY OF STITCHES, OR NUMBER OF STITCHES SEWED IN WHILE NEEDLE BAR IS CIRCLING THE EYE

LOOSEN SCREW (H) AND ADJUST THE WEDGE (J) TO SUIT. MOVEMENT TO THE REAR OF MACHINE WILL DECREASE THE NUMBER OF STITCHES IN EYE. MOVEMENT TO THE FRONT WILL INCREASE THEM.

LESS

MORE

FIG. 2

LESS

MORE

IF THIS TYPE OF WEDGE IS USED ADJUST IN OPPOSITE DIRECTION TO THAT SHOWN IN FIG. 2

FIG. 5

**TENSION NOTES**

WITH EITHER SPLIT OR SOLID TENSION DISCS - ADJUSTMENT IS MADE WITH NUT (K) FIG. 3 - SCREWING IT INWARD WILL TIGHTEN THE TENSION - OUTWARD WILL LOOSEN IT.

NOTE - TO OBTAIN A DESIRED RESULT IT MAY BE NECESSARY TO ADJUST EACH TENSION SEPARATELY OR JOINTLY - AS A RULE THE UPPER TENSION IS MUCH TIGHTER THAN THE LOWER.

TENSION FOR UPPER SYSTEM ON HEAD

TENSION FOR LOWER SYSTEM ON FOOT

TO TIGHTEN THE UNDER TENSION USE NUT (L) - INWARD TO TIGHTEN - OUTWARD TO LOOSEN

FIG. 3

FIG. 4

**MODEL-101 MACHINE ADJUSTMENTS**  
CORRECTIVE AND MAINTENANCE

**NEEDLE BAR AND RACE LINE UP ADJUSTMENTS (C)**

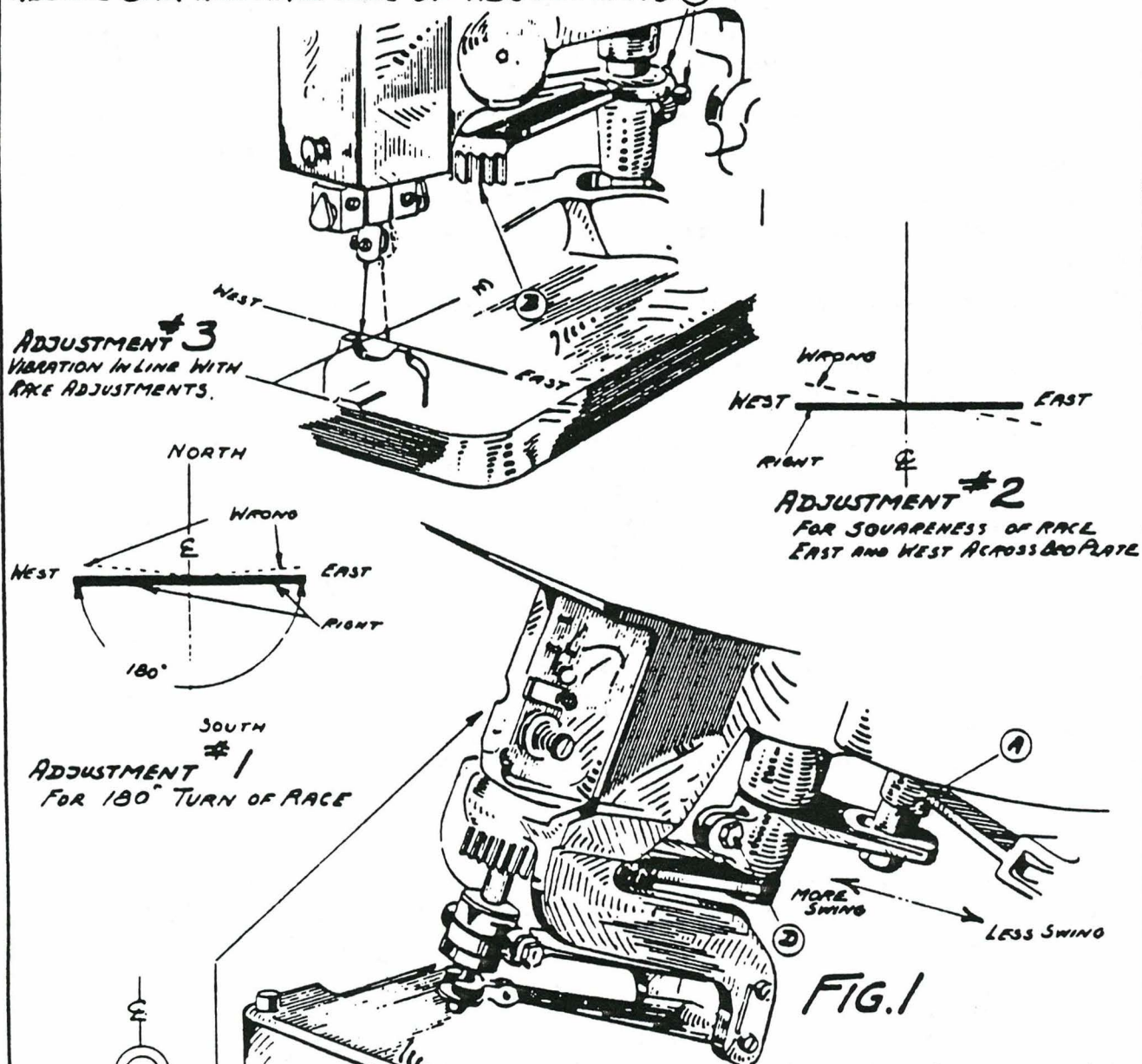

**ADJUSTMENT #3**  
VIBRATION IN LINE WITH  
RACE ADJUSTMENTS.

**ADJUSTMENT #2**  
FOR SQUARENESS OF RACE  
EAST AND WEST ACROSS BED PLATE

**ADJUSTMENT #1**  
FOR 180° TURN OF RACE

**FIG. 1**

IT IS IMPERATIVE THAT THE RACE SWING EAST AND WEST IS 180° ONLY (#3). IT IS IMPERATIVE THAT THIS 180° BE SQUARE WITH THE CENTER LINE OF THE BED PLATE (#2). ALSO THE NEEDLE BAR ASSEMBLY MUST VIBRATE SQUARELY EAST AND WEST IN HARMONY WITH THE RACE (#3)

TO PROCEED WITH THESE ADJUSTMENTS, FOLLOW THIS SEQUENCE -

- ① ADJUST STUD (A) TO OBTAIN ADJUSTMENT #1
- ② LOOSEN CLAMP SCREW (B) TO OBTAIN ADJUSTMENT #2
- ③ RECHECK ADJ. #1 - IF WRONG REPEAT ADJUSTMENTS #2 AND #1 UNTIL THEY ARE RECONCILED.
- ④ WHEN THESE ADJUSTMENTS ARE CORRECT, ADJUST THE NEEDLE BAR ASSEMBLY EAST AND WEST IN HARMONY WITH THE RACE BY LOOSENING SCREWS (C) IN SECTOR D (#3)

WHEN ASSEMBLING SECTORS MESH THE TEETH ON SECTOR & WITH RACE NORTH AND SOUTH AS IN FIG. #1 AND #4 - SO THAT SECTOR TEETH WILL NOT DISENGAGE GEAR TEETH AT EITHER END OF SWING

**MODEL-101 MACHINE ADJUSTMENTS**  
CORRECTIVE AND MAINTENANCE - CONTINUED -

**EQUALIZING THE LOOPERS**

THE LOOPERS (A) AND (B) WHEN PROPERLY ADJUSTED WILL ASSUME THE POSITIONS IN FIG. 1 - WITH THEIR POINTS ON CENTER LINE OF NEEDLE ON ALTERNATE STROKES AFTER THE NEEDLE BAR HAS RISEN  $\frac{3}{32}$ " FROM ITS LOWEST POSITION.

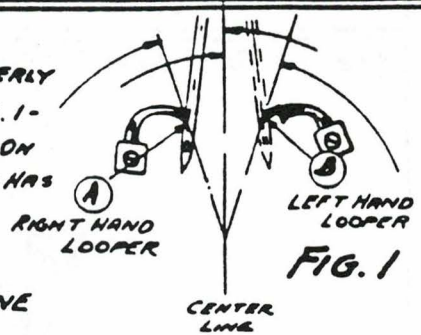

FIG. 1

TO MAKE THIS ADJUSTMENT - REMOVE THE CLAMP PLATES - REMOVE THE THROAT PLATE FROM THE RACE - TURN THE MACHINE WITH THE L.H. HANDWHEEL (WITH HANDLE) UNTIL THE LOOPERS ARE IN FRONT.

TURN THE R.H. HANDWHEEL (KNURLED RIM) UNTIL THE NEEDLE IS AT ITS LOWEST POINT

RAISE THE NEEDLE SLOWLY WITH THIS SAME HANDWHEEL UNTIL THE L.H. LOOPER POINT IS IN POSITION SHOWN (FIG. 2)

WHILE IN THIS POSITION MEASURE THE DISTANCE THAT THE NEEDLE BAR PROTRUDES ABOVE THE CAP (D) WITH A SCALE AND MAKE A NOTE OF THIS DIMENSION

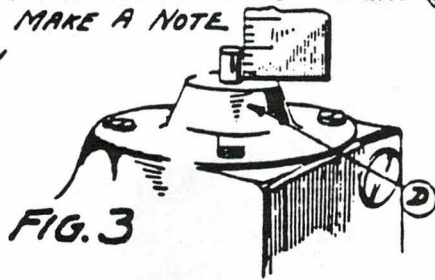

FIG. 3

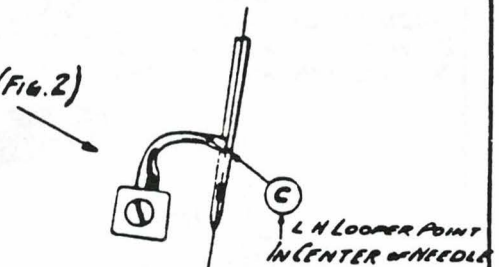

FIG. 2

TURN THE R.H. HANDWHEEL AGAIN UNTIL THE RIGHT HAND LOOPER IS IN POSITION SHOWN (FIG. 4) AND WHILE IN THIS POSITION MEASURE AGAIN AS ABOVE - IMPORTANT -

THESE TWO MEASUREMENTS MUST BE THE SAME FOR THE PROPER WORKING OF THIS MECHANISM.

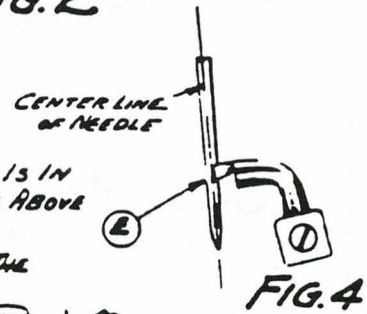

FIG. 4

TO EQUALIZE THIS DIMENSION, LOOSEN SCREW (F) IN RACE AND MOVE CROSSHEAD (G) UP OR DOWN UPON SPINDLE (H) AS REQUIRED

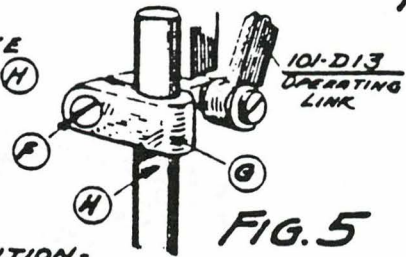

FIG. 5

AFTER THIS HAS BEEN DONE - TURN THE R.H. HANDWHEEL (KNURLED RIM) UNTIL NEEDLE IS IN ITS LOWEST POSITION.

MEASURE AGAIN AT THE CAP AS ABOVE AND RAISE THE NEEDLE BAR  $\frac{3}{32}$ " OF AN INCH - WITH THE NEEDLE BAR IN THIS POSITION - LOOPERS SHOULD BE AS SHOWN IN FIG. 2 AND FIG. 4.

IF THEY ARE NOT -

LOOSEN SCREW (J) AND TURN THE CORE (K) SLIGHTLY IN EITHER DIRECTION WITH THE SPECIAL WRENCH, UNTIL THE LOOPERS ARE IN THESE POSITIONS.

ADJUSTMENT IN DIRECTION OF ARROW ADVANCES THE LOOPERS ACROSS THE NEEDLE.

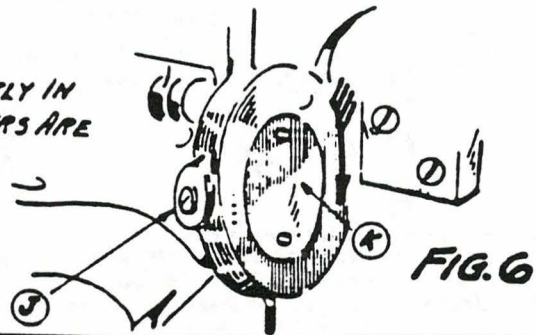

FIG. 6

# MODEL-101 MACHINE ADJUSTMENTS

CORRECTIVE AND MAINTENANCE - CONTINUED -

## LOOPER AND SPREADER ADJUSTMENT

**IMPORTANT**-BEFORE MAKING THESE ADJUSTMENTS CHECK ADJUSTMENTS OF RACE SHEET #9 AND FOR EQUALIZING:- SHEET #10

POSITIONS OF NEEDLE WHEN IT HAS RISEN  $\frac{3}{32}$ " FROM ITS LOWEST POINT ON ALTERNATE STROKES.

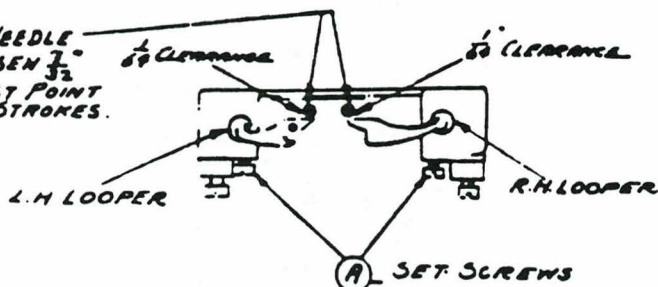

FIG. 1

THE LOOPERS ARE HELD IN PLACE WITH THE SET SCREW A - IF NECESSARY LOOSEN THESE SCREWS AND ADJUST THE LOOPERS SO THAT THERE IS A SLIGHT CLEARANCE ( $\frac{1}{64}$  OF AN INCH) BETWEEN THEM AND THE NEEDLE WHEN IN POSITIONS SHOWN IN FIG. 1

THE SPREADER LOCATION IS CONTROLLED BY SPREADER STOPS, THESE ARE SET WITH SET SCREWS AS ARE THE LOOPERS.

WHEN THE NEEDLE IS AT ITS LOWEST POSITION. ADJUST THESE STOPS SO THAT THE SPREADERS ARE IN LOCATIONS SHOWN IN FIG. 2.

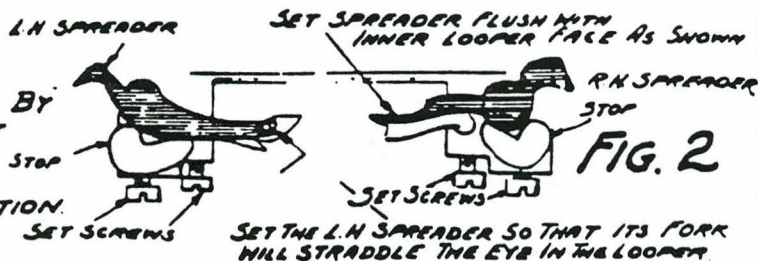

FIG. 2

NEEDLE POSITIONS IN ALTERNATE DOWNWARD STROKES. JUST BEFORE REACHING LOWEST POINT



FIG. 3

THE POSITION OF THE NEEDLE AS THE LOOPERS AND SPREADERS ARE BACKING AWAY IS AS SHOWN IN FIG. 3. IT IS IMPORTANT THAT THE SPACE BETWEEN THE NEEDLE AND SPREADERS IS EQUAL FOR EACH SPREADER. THIS ADJUSTMENT CAN BE MADE WITH NUT (B) ON CONNECTION (C) FIG. 4 - NOTE WHEN THE LIMIT OF THE THREAD (C) IS REACHED, AN ADDITIONAL ADJUSTMENT IS PROVIDED AS SHOWN IN FIG 5 - LOOSEN SCREW (E) AND RAISE OR LOWER CROSSHEAD (D) ADJUST AGAIN AS IN FIG. 4

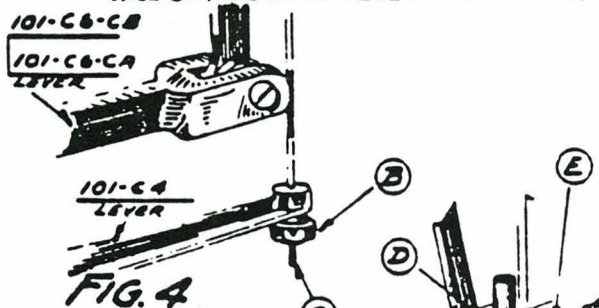

FIG. 4

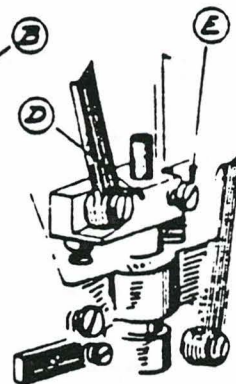

FIG. 5

## NEEDLE BAR ADJUSTMENT

TURN THE R.H. HANDWHEEL (UNWIND ARM) UNTIL THE NEEDLE BAR HAS RISEN  $\frac{3}{32}$ " FROM ITS LOWEST POINT AND IS IN POSITION SHOWN.

IN THIS POSITION THE EYE OF THE NEEDLE SHOULD BE ABOUT  $\frac{3}{32}$ " BELOW THE LOOPER AS SHOWN IN FIG. 6



FIG. 6

TO ADJUST TO THIS DIMENSION LOOSEN THE SCREWS (F) IN FIG. 7 AND RAISE OR LOWER THE NEEDLE BAR (G) TO SUIT

WHEN IN THIS POSITION NEEDLE HAS STARTED UP AND NEEDLE RISEN  $\frac{3}{32}$ " OF AN INCH FROM ITS LOWEST POINT (G)

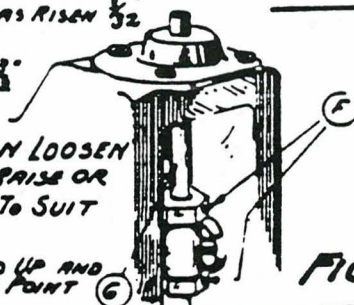

FIG. 7

**MODEL-101-MACHINE ADJUSTMENTS**  
 CORRECTIVE AND MAINTENANCE-CONTINUED-

**TO ADJUST PLAY IN SPLIT COLLAR YOKE (A)**  
 THIS YOKE MUST BE ADJUSTED TO WORK SMOOTHLY  
 BUT WITHOUT EXCESSIVE PLAY.  
 PART (B) IS A NUT-LOOSEN SCREW (C) AND  
 SCREW UP NUT (B) TO SUIT.

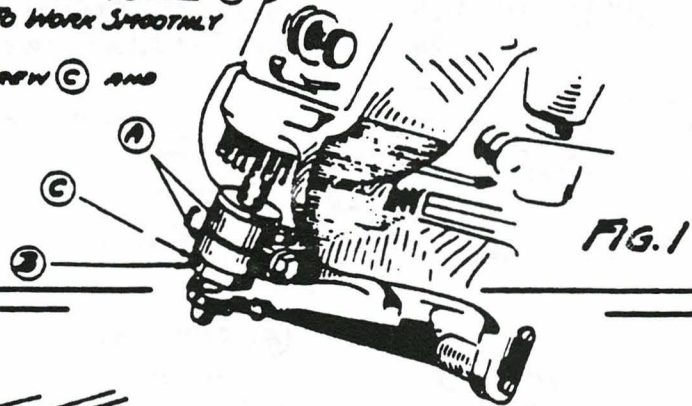

FIG. 1

**TO LINE UP AND ADJUST  
 THE CUTTING LEVER.**

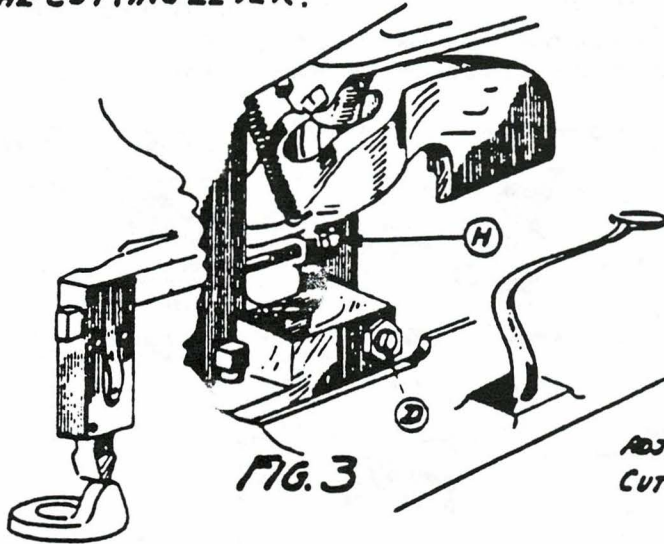

FIG. 3

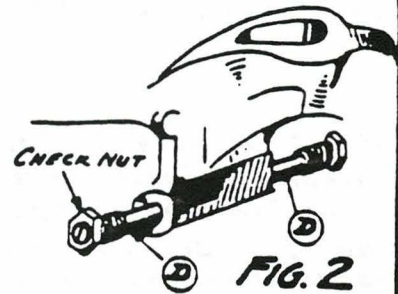

FIG. 2

THE CUTTING LEVER IS SUSPENDED  
 UPON TWO ADJUSTABLE STUDS (D)  
 ADJUST THESE STUDS FOR CENTRALIZATION OF  
 CUTTING LEVER.

TO ADJUST CUTTING PRESSURE, TURN NUTS  
 (H) INWARD FOR MORE PRESSURE OR  
 OUTWARD FOR LESS.  
**IMPORTANT:** RELEASE CUTTING PRESSURE  
 COMPLETELY BEFORE INSTALLING A NEW  
 CUTTING STEEL.

WHEN INDENTATION OF KNIFE IN CUTTING  
 STEEL HAS BECOME TOO DEEP, THE FACE SHOULD  
 BE FILED UNTIL THE IMPRESSION IS BARELY SEEN.  
 FOLLOW UP BY ADJUSTING THE CUTTING  
 PRESSURE TO CUT.



WHEN REPLACING WITH NEW BLOCK, LEVEL THE CUTTING SURFACE  
 WITH A FILE UNTIL IMPRESSION OF CUTTER IS DISTINCT  
 THROUGHOUT ITS LENGTH. (ON BOTH CUT AFTER AND CUT BEFORE  
 MACHINES)

CUTTERS MAY BE ALIGNED AS  
 TO CENTER AND POSITION OF EYE.  
 LOOSEN SCREW (E) AND ADJUST  
 KNIFE FORWARD OR BACKWARD  
 FOR CORRECT EYE POSITION

FOR CENTERING, ADJUST CUTTER IN EITHER DIRECTION  
 WITH SCREWS (G) FOR ADDITIONAL ADJUSTMENT  
 LOOSEN THREE SCREWS (F) AND MOVE BLOCK IN  
 THE DIRECTION DESIRED.

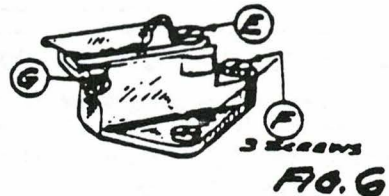

FIG. 5

**MODEL-101 - MACHINE ADJUSTMENTS.**  
**CORRECTIVE AND MAINTENANCE - CONTINUED -**

**TO ADJUST THE CLAMP PLATES PARALLEL WITH LEDGE.**  
 PRESS THE CLAMP PLATE FIRMLY AGAINST THE LEDGE OF THE  
 BED PLATE WITH THE HAND - DEPRESS THE CLAMP LEVER  
 (101-B19). THIS WILL HOLD THE CLAMP PLATE IN POSITION.  
 ADJUST THE SCREW (A) FIRMLY AGAINST EDGE (B)  
 RELEASE THE CLAMP LEVER - AND SCREW (A) WILL BE IN ADJUSTMENT.

CLAMPS SHOULD BE PARALLEL  
 WITH LEDGE ON BED PLATE

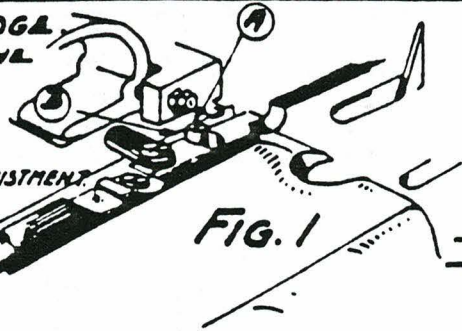
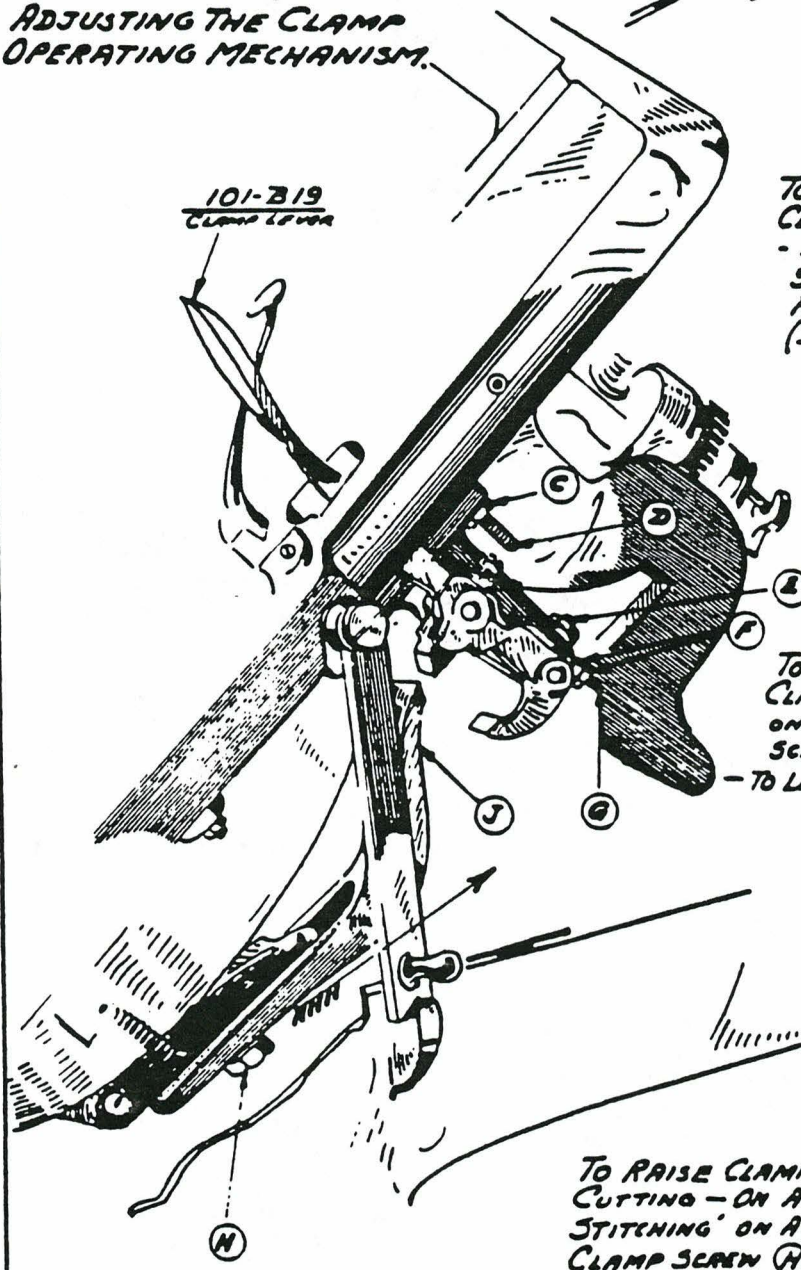

FIG. 1

**ADJUSTING THE CLAMP  
 OPERATING MECHANISM.**



101-B19  
 CLAMP LEVER

**TO RAISE CLAMP ARMS FOR MORE  
 CLEARANCE BETWEEN MATS AND FEET.**  
 - LOOSEN NUT (C) AND SCREW OUT  
 SCREW (D)  
 FOR LESS CLEARANCE SCREW INWARD  
 (SET CHECK NUT AFTER ADJUSTMENT)

**TO APPLY MORE PRESSURE BETWEEN  
 CLAMP ARMS AND MATS - LOOSEN NUT (B)  
 ON STUD AND MOVE IT UPWARD WITH  
 SCREW (C) SET WITH NUTS (F) AND (E)  
 - TO LESSEN PRESSURE MOVE STUD DOWNWARD -**

**TO RAISE CLAMPS SOONER OR LATER - AFTER  
 CUTTING - ON A 'CUT AFTER' MACHINE - OR 'AFTER  
 STITCHING' ON A 'CUT BEFORE' MACHINE - LOOSEN  
 CLAMP SCREW (H) AND MOVE ARM (J) IN DIRECTION OF  
 ARROW FOR 'EARLIER' RISE AND THE REVERSE FOR  
 'LATER' RISE.**

**NOTE.**  
 THIS ADJUSTMENT WILL NOT RAISE CLAMPS SOONER OR  
 LATER ON CORD TRIM MACHINE.

FIG. 2



**MODEL-101 MACHINE ADJUSTMENT**  
**CORRECTIVE AND MAINTENANCE - CONTINUED.**

**TO ADJUST THE TRIP LEVER**

TO EQUALIZE THE ENDS OF THE STITCHING  
 LOOSEN NUT (A) ON STOP SCREW (B) AND  
 SCREW IN OR OUT AS REQUIRED.

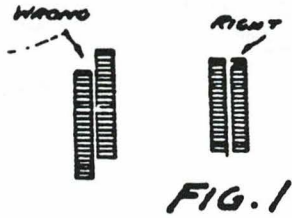

FIG. 1

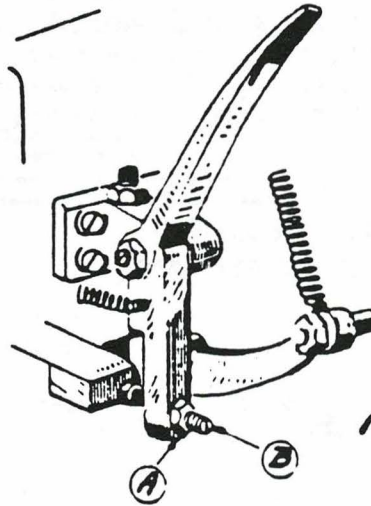

FIG. 2

**TO CORRECT DISTORTION OF EYE**

LOOSEN NUT (C) AND MOVE STUD IN  
 SLOT OF LEVER (E) UNTIL SHAPE OF  
 EYE IS CORRECT.



FIG. 3

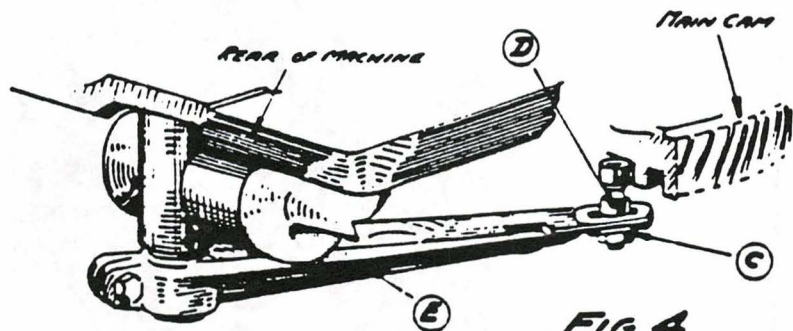

FIG. 4

**TO ADJUST THE ROLL PRESSURE ON LENGTH GAUGE.**

CRANK THE MACHINE UNTIL IT IS IN THE STOPPING POSITION;  
 TURN THE R. H. KNURLED STITCH WHEEL UNTIL IT IS LOCKED AND WHEEL WILL NOT TURN  
 FURTHER.

WHEN IN THIS POSITION ROLL (G) SHOULD JUST  
 BARELY REST ON GAUGE (H) BUT BE FREE TO  
 REVOLVE.

ADJUSTMENT MAY BE MADE  
 WITH SCREW (J) -  
 DEPRESSING THE SCREW WILL LIFT  
 THE ROLL - RAISING THE SCREW (J)  
 WILL LOWER THE ROLL.

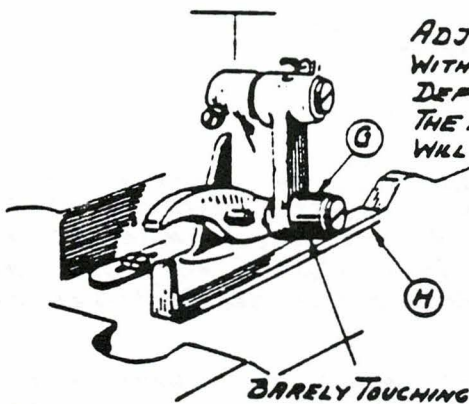

FIG. 5

BARELY TOUCHING AT THIS POINT

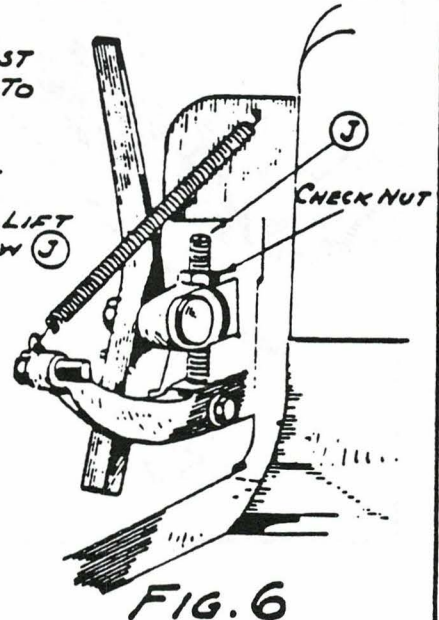

FIG. 6

MODEL 101

MACHINE ADJUSTMENT  
CORRECTIVE AND MAINTENANCE-CONTINUED-

TO ADJUST THE ROCKER ARM AND STOP MOTION.

CRANK THE MACHINE WITH L.H. HANDWHEEL, TO ITS STOPPING POSITION.

WITH THE R.H. HANDWHEEL (KNURLED RIM) TURN UNTIL DOG (A) IS IN CONTACT WITH THE STOP BOLT (B) — WHEN IN THIS POSITION ROLLER (C) SHOULD HAVE A VERY LIGHT CONTACT ON LOW POINT OF CAM (D) ON HANDWHEEL

MAKE ADJUSTMENT BY LOOSENING SCREW (E) (FIG. 3A) AND SWING ROCKING LEVER (L) TO SUIT. SEE NOTE AT BOTTOM LEFT OF SHEET.

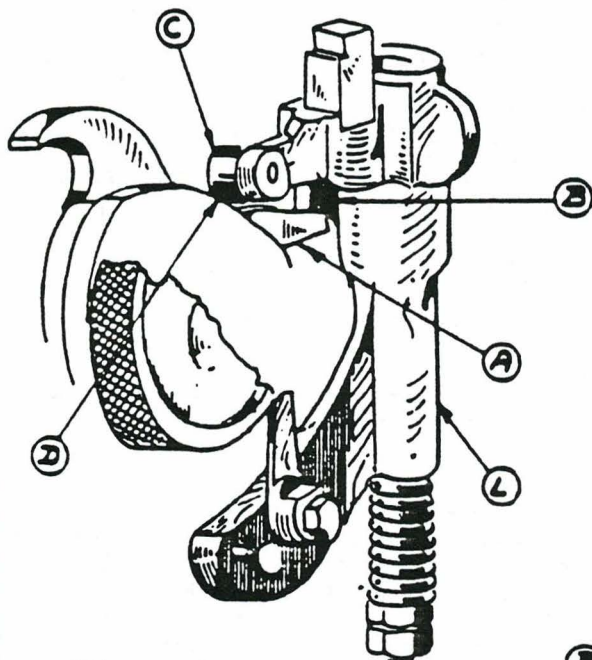

FIG. 1A

WITH THE L.H. HANDWHEEL, CRANK THE MACHINE UNTIL THE ROCKING LEVER (L) IS AS FAR BACK AS IT WILL GO.

(AT THIS POINT THE DOG (A) AND THE STOP BOLT (B) (FIG. 2A) ARE ABOUT 1/8" APART AT (X))

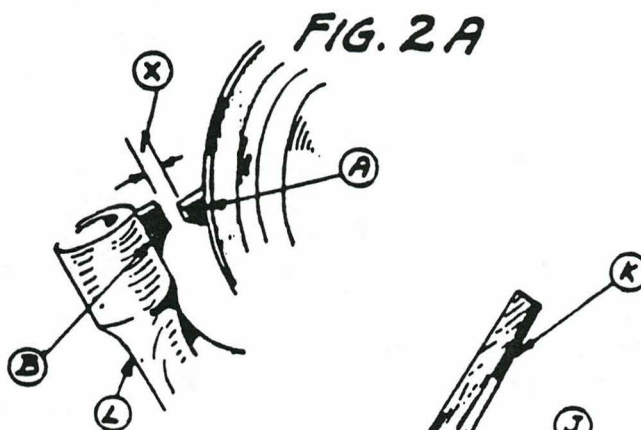

FIG. 2A

NOTE ALSO THAT ROLLER (C) IS AT THE PEAK OF GAUGE (H)

WHEN THE PARTS ARE IN THE POSITION SHOWN THERE MUST BE A CLEARANCE OF ABOUT 1/32" AT (XX) - IF NOT- ADJUST BY LOOSENING NUT (J) AND RAISE OR LOWER LEVER (K) TO SUIT

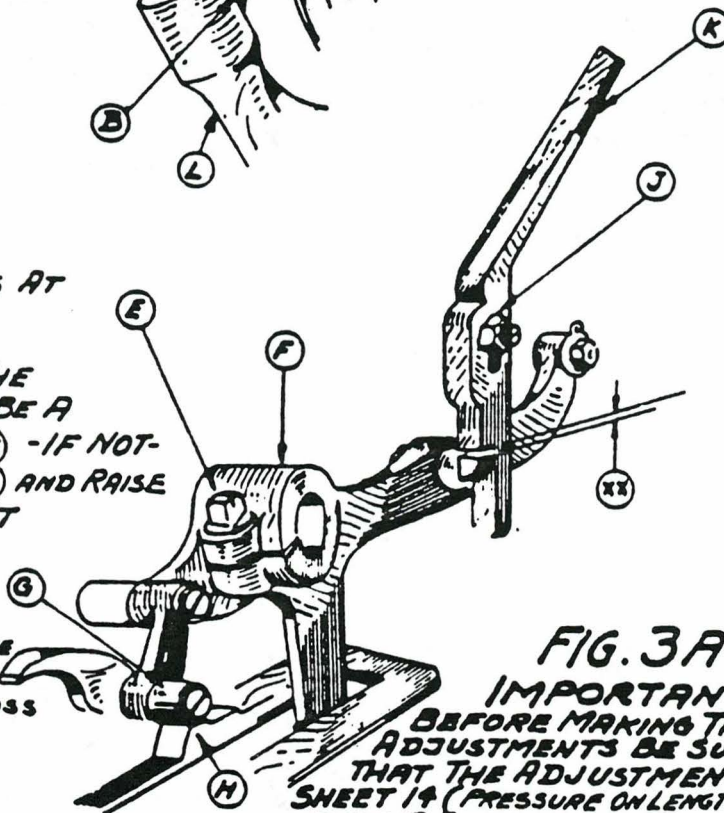

FIG. 3A

**NOTE**  
BEFORE TIGHTENING SCREW (E) BE SURE PARTS (F) AND (L) BOTH BEAR AGAINST SIDES OF THE BOSS ON HEAD CASTING.

**IMPORTANT**  
BEFORE MAKING THESE ADJUSTMENTS BE SURE THAT THE ADJUSTMENTS ON SHEET 14 (PRESSURE ON LENGTH GAUGE) ARE CORRECT.

**MODEL-101 - MACHINE ADJUSTMENTS**

*CORRECTIVE AND MAINTENANCE - CONTINUED -*

**ADJUSTING THE STOP LATCH ON STITCHING WHEEL**

**NOTE**

FACTORY ADJUSTMENT OF THIS ECCENTRIC IS MADE SO THAT THICK SIDE OF ECCENTRIC (X) IS TOWARD REAR. THIS POSITION MUST BE MAINTAINED TO PREVENT SCREW (B) FROM BACKING OUT.



PULLEY

**FIG. 1**

HAND WHEEL

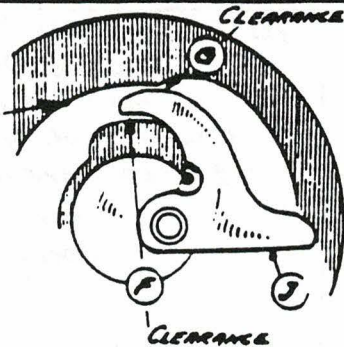

**FIG. 2**

**ADJUSTING THE TRIGGER SETTING MECHANISM.**

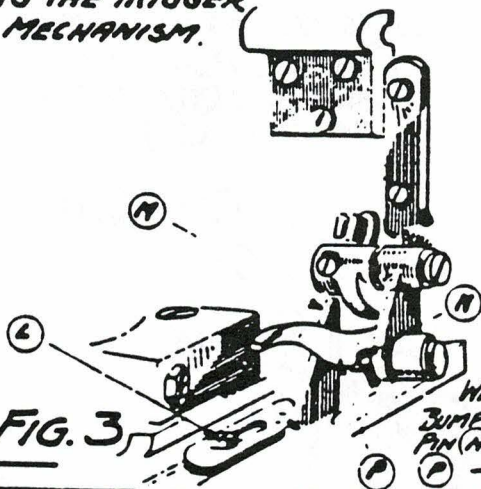
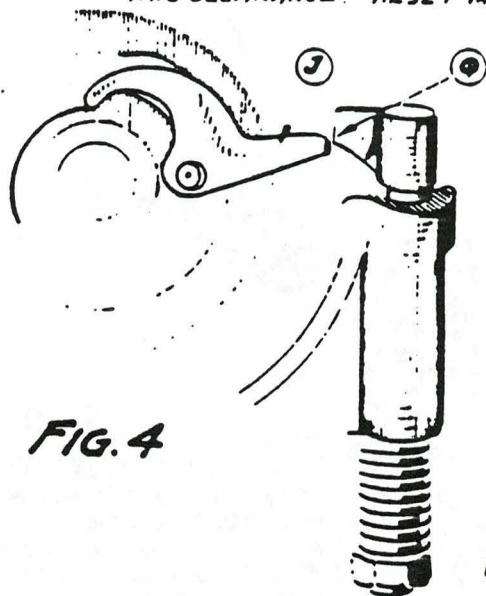

**FIG. 3**

LOOSEN SCREW (B) TURN ECCENTRIC (E) WHICH WILL ADJUST LATCH (D) AGAINST LEDGE (C) - ADJUST TO RAISE OR LOWER UNTIL THERE IS A CLEARANCE OF DOG (J) AS IN FIG. 2. BETWEEN CAM AND WHEEL AT (F) AND CAM IN PULLEY AT (G) ADJUSTMENT SHOULD BE MADE WHEN R.H. STITCH WHEEL IS LOCKED.

WHEN THE MACHINE IS AT THE STOPPING POSITION BUMPER (M) SHOULD BE ADJUSTED AGAINST PIN (N) SO THAT THE PIN (N) WILL FALL FREELY INTO NOTCH AND ENGAGE PART (P) - THIS SETS THE MACHINE FOR STITCHING.

**TO ADJUST THE TIMING OF THE L.H. HANDWHEEL IN RELATION TO ROCKER SHAFT AND LEVER**  
 (CRANK THE MACHINE BACK UNTIL STOP BOLT CONTACT POINT (Q) BARELY DISENGAGES DOG (J) AS IN FIG. 4 - CONTACT POINTS (S) AND (R) ON L.H. HANDWHEEL SHOULD JUST CLEAR AS SHOWN IN DETAIL (FIG. 5) - IF NOT, LOOSEN SCREW (T) IN SPOOL AND MOVE WHEEL (U) IN OR OUT TO OBTAIN THIS CLEARANCE. RESET THE SET SCREW (T) SECURELY



**FIG. 4**

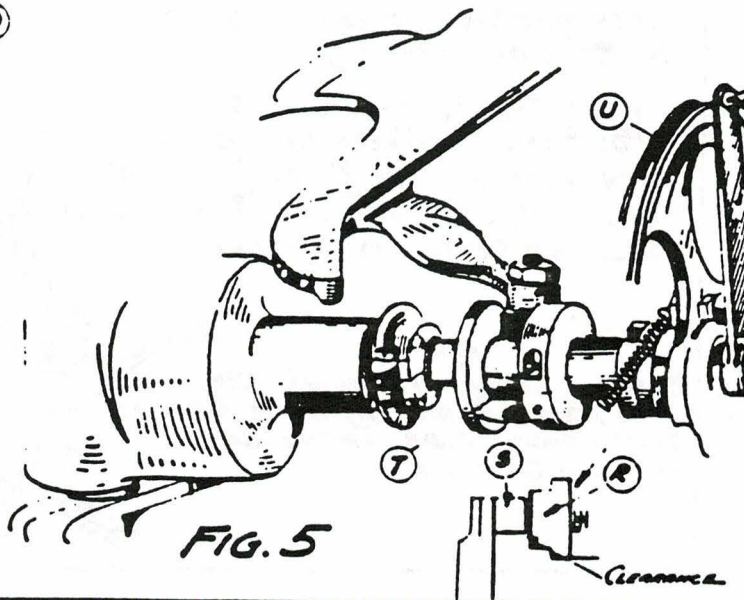

**FIG. 5**

## MODEL-101 - MACHINE ADJUSTMENTS CORRECTIVE AND MAINTENANCE

**TO ADJUST L.H. HANDWHEEL TO DISENGAGE AT THE STOPPING POSITION OF THE MACHINE.**

IN THIS POSITION CONTACT POINTS (F) (E) SHOULD HAVE A CLEARANCE OF ABOUT  $62^{\circ}$  - IF NOT; LOOSEN NUT (A) AND MOVE STUD (B) IN SLOT FORWARD OR BACK AS REQUIRED TO OBTAIN THIS CLEARANCE.

**IMPORTANT -**  
R.H. STOP WHEEL (KNURLED RIM) MUST BE LOCKED WHEN MAKING THIS ADJUSTMENT

REAR OF MAIN

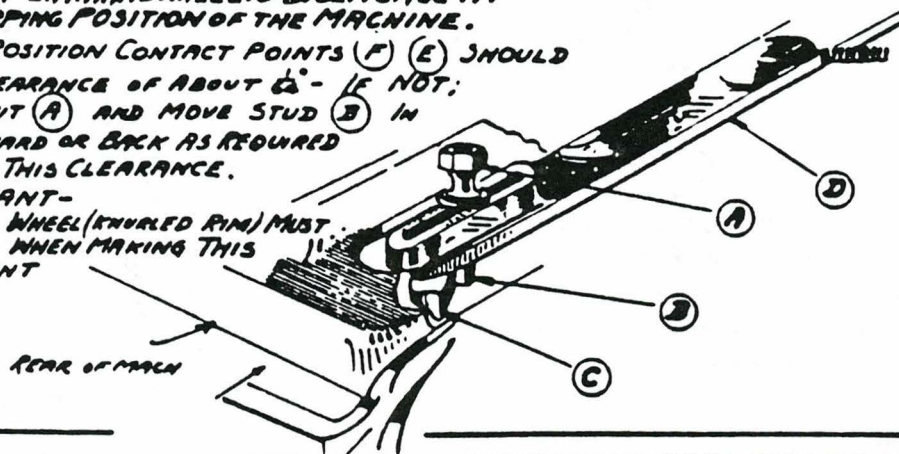

FIG. 1

**TO ADJUST FOR FRICTION ON WORM SHAFT**

LOOSEN SCREW (H) ON COLLAR (G) SET COLLAR SO THAT THERE IS A COMPRESSION OF THE SPRING WASHER -

AMOUNT OF COMPRESSION DETERMINES THE AMOUNT OF FRICTION.

DO NOT SET THIS COLLAR TOO TIGHTLY.

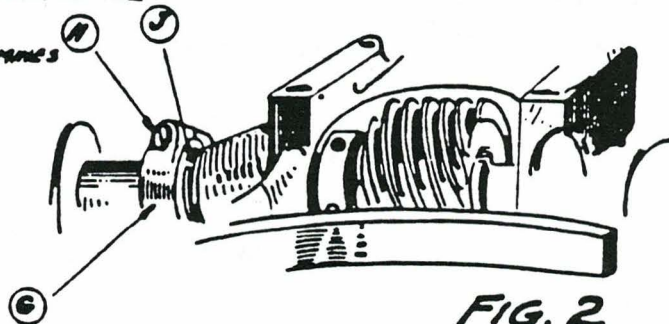

FIG. 2

**TO ADJUST FOR FRICTION ON MAIN CAM.**

LOOSEN NUT (K)  
ADJUST SCREW (L) INWARD FOR MORE FRICTION AND OUTWARD FOR LESS

DO NOT PLACE TOO MUCH FRICTION AGAINST THE CAM

FIG. 3

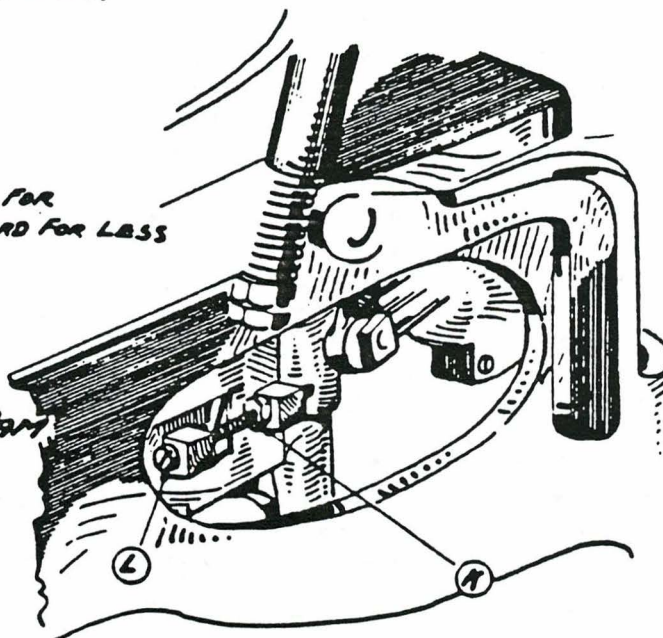

**CUT BEFORE**  
**MODEL-101 MACHINE ADJUSTMENTS**  
**CORRECTIVE AND MAINTENANCE**

**- IMPORTANT -**

**BEFORE MAKING THE ADJUSTMENTS SHOWN ON THIS SHEET, BE SURE THE RIGHT HAND STITCH WHEEL IS LOCKED**

**VERTICAL SETTING OF TRIMMING KNIFE**  
 THE TRIMMING KNIFE (A) FIG.1 SHOULD BE SET SO IT WILL CLEAR THE UNDER SIDE OF THROAT PLATE (B) AT (X), AND TOP OF RIGHT HAND SPREADER STOP (C) AT (XX) TO OBTAIN THIS SETTING. LOOSEN SCREW (D) FIG.1 AND MOVE TRIMMING KNIFE (A) UP OR DOWN TO SUIT. TIGHTEN SCREW SECURELY.

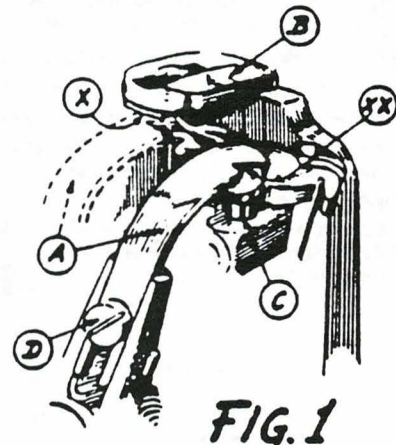

**FIG. 1**

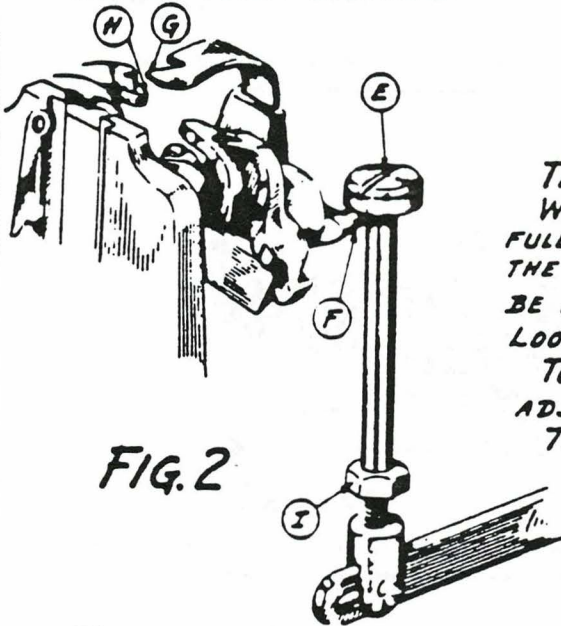

**FIG. 2**

**TRIMMING KNIFE ACTUATOR ADJUSTMENT**  
 WHEN ACTUATOR (E) FIG. 2. HAS OF ITS OWN ACTION FULLY DEPRESSED THE END OF TRIMMER HOLDER (F) THE EXTREME POINT OF THE TRIMMING KNIFE (G) SHOULD BE IN LINE WITH THE POINT OF THE RIGHT HAND LOOPER (H).

TO OBTAIN THIS SETTING, LOOSEN LOCK NUT (I) AND ADJUST ACTUATOR (E) UP OR DOWN TO SUIT. TIGHTEN LOCK NUT (I) SECURELY.

**TRIMMING KNIFE STOP POSITION.** — THE STOP POSITION GOVERNS THE EXTENT OF MOVEMENT AT THE POINT OF TRIMMING — SEE FIG. 3.  
 THE CUTTING EDGE OF THE TRIMMING KNIFE (J) SHOULD BE ADVANCED SUFFICIENTLY BEYOND THE SHOULDER OF THE R.H. LOOPER TO ASSURE FULL ENGAGEMENT AND CONSTANT TRIMMING OF THE FRONT LEG OF THE THREAD LOOP. — TO CHECK THIS ADJUSTMENT PROCEED AS FOLLOWS:

WHEN ACTUATOR (K) HAS RISEN TO ITS FULL HEIGHT THE KNIFE SHOULD BE AT MINIMUM IN AN ADVANCED POSITION TO THE RIGHT TO CLEAR THE SLOT IN THE THROAT PLATE AT (L) — TO ADVANCE THE KNIFE FURTHER TO THE RIGHT, LOOSEN CHECK NUT (M) AND TURN ADJUSTING SCREW (N) SUFFICIENTLY UPWARD TO GAIN THE MAXIMUM OF MOVEMENT, BUT BEING SURE THAT SOME CLEARANCE IS ALWAYS MAINTAINED UNDER HEAD OF (K) AT (O)

IF FOR ANY REASON IT IS DESIRED TO REMOVE TRIMMING MECHANISM TO FACILITATE LOOPER ADJUSTMENT — REMOVE SPRING (P) AND RAISE SLIGHTLY SPRING CLIP (Q) FIG 3 AND SLIDE UNIT OFF THE STUD (R).

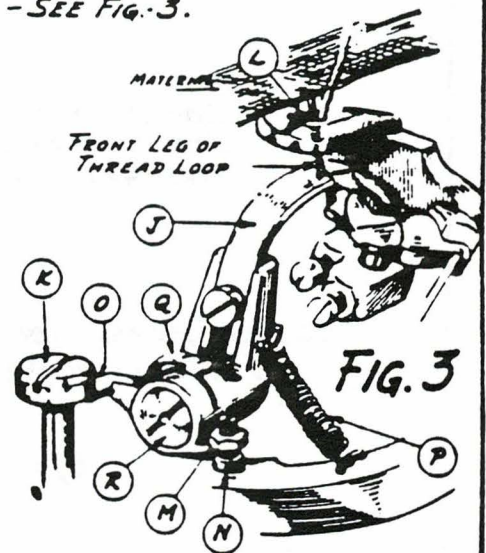

**FIG. 3**



**CUT BEFORE**  
**MODEL-101 MACHINE ADJUSTMENTS**  
**CORRECTIVE AND MAINTENANCE - CONTINUED.**

**UPPER THREAD DRAW OFF (ROCKING TENSION TYPE)**

THE AMOUNT OF THREAD REQUIRED TO START THE NEXT BUTTON HOLE VARIES WITH THE CONDITIONS AND CLASSES OF WORK. USUALLY THIN WORK REQUIRES MORE THREAD FOR STARTING PURPOSES THAN HEAVY WORK. IF MORE THAN ONE GRADE OF WORK IS PASSED THRU THE MACHINE, IT IS DESIRABLE TO MAKE THE ADJUSTMENT ON THE LIGHTEST MATERIALS.

REFER TO SHEETS  
 2 AND 3 FOR COMPLETE  
 THREADING DIAGRAMS.

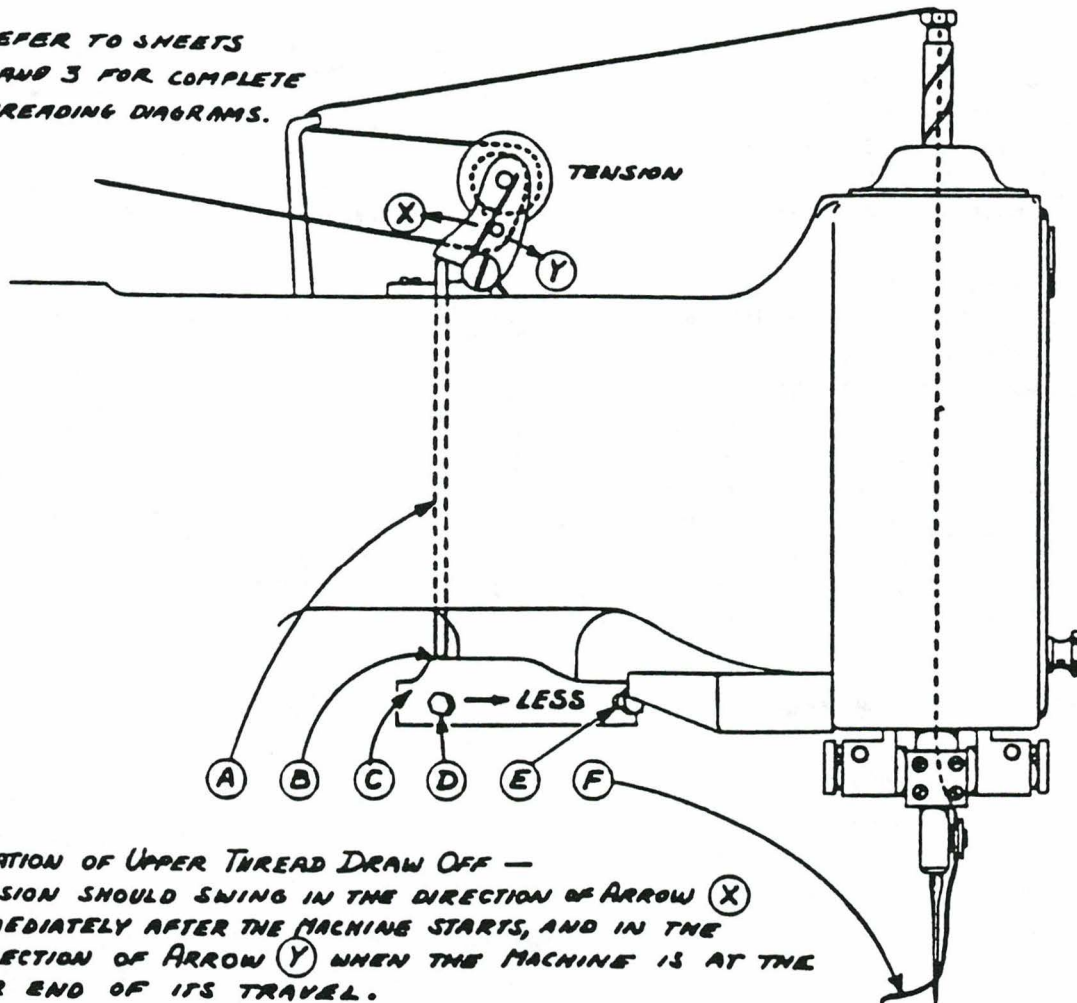

**OPERATION OF UPPER THREAD DRAW OFF —**

TENSION SHOULD SWING IN THE DIRECTION OF ARROW (X) IMMEDIATELY AFTER THE MACHINE STARTS, AND IN THE DIRECTION OF ARROW (Y) WHEN THE MACHINE IS AT THE FAR END OF ITS TRAVEL.

**ADJUSTMENT OF UPPER THREAD DRAW OFF —**

TO OBTAIN MAXIMUM LENGTH OF STARTING THREAD AT (F), MAKE SURE MACHINE IS IN ITS NORMAL STOPPING POSITION. LOOSEN SCREWS (D) AND (E) AND ROTATE CAM (C) TO THE POINT WHERE PIN (A) IS AT THE VERY TOP OF THE CAM RISE AT (B) AS SHOWN ABOVE. THEN TIGHTEN SCREWS (D) AND (E) SECURELY.  
 TO DECREASE LENGTH OF STARTING THREAD AT (F) ADJUST THE POSITION OF CAM (C) AS REQUIRED IN THE DIRECTION OF ARROW MARKED LESS.

**NOTE —** IF MACHINE IS NOT EQUIPPED WITH THIS TYPE OF UPPER THREAD DRAW OFF, SEE NEEDLE BAR TYPE DRAW OFF ON SHEET 20.

# CUT BEFORE

## MODEL-101 MACHINE ADJUSTMENTS

CORRECTIVE AND MAINTENANCE - CONTINUED.

### -NOTE-

THE AMOUNT OF THREAD REQUIRED TO START THE NEXT BUTTON HOLE VARIES WITH THE CONDITIONS AND CLASSES OF WORK. USUALLY THIN WORK REQUIRES MORE THREAD FOR STARTING PURPOSES THAN HEAVY WORK. IF MORE THAN ONE GRADE OF WORK IS PASSED THRU THE MACHINE, IT IS DESIRABLE TO MAKE THE ADJUSTMENT ON THE LIGHTEST MATERIALS.

TO ADJUST FOR MORE OR LESS THREAD, LOOSEN NUT (D) FIG.1, AND SWING DISC (C) IN THE DIRECTION SHOWN FOR THE DESIRED RESULT.

THE ABSOLUTE MAXIMUM OF THREAD THAT CAN BE DRAWN OFF IS REACHED WHEN DISC (C) HAS ENGAGED THE THREAD AS ILLUSTRATED IN FIG.1A - AND THE THREAD LINES ARE PARALLEL AT (B) AS THE MACHINE IS STITCHING ON THE SECOND SIDE OF THE BUTTON HOLE.

DISC ADJUSTMENT SHOWN IN FIG.1 IS THE MOST DESIRABLE LOCATION FOR AVERAGE SEWING.



FIG.1A  
VIEW SHOWING POSITION OF DISCS  
FOR MAXIMUM OF THREAD DRAW-OFF.

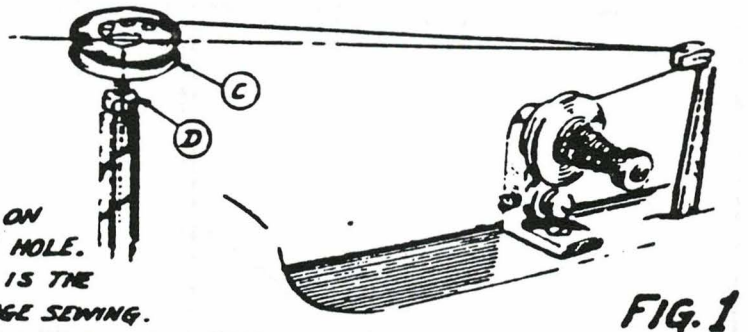

FIG.1

## COMBINED DRAW-OFF AND UNDER THREAD TENSION RELEASE

### -NOTE-

THE LOWER THREAD TENSION SHOULD BE FULLY RELEASED WHEN MACHINE HAS COMPLETED THE BUTTON HOLE.

TO ADJUST, LOOSEN NUT (A) FIG.2, AND RAISE OR LOWER STUD (B) A SUFFICIENT AMOUNT TO OVERCOME THE INFLUENCE OF THE TENSION SPRING.

TIGHTEN NUT (A) SECURELY.

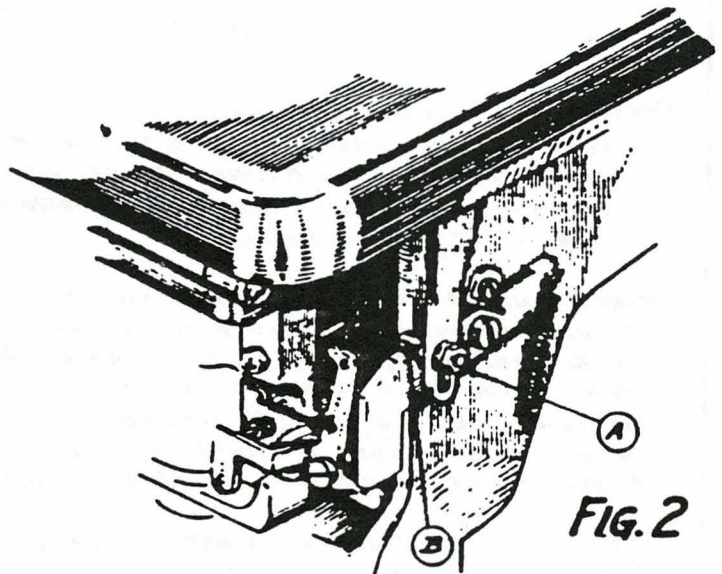
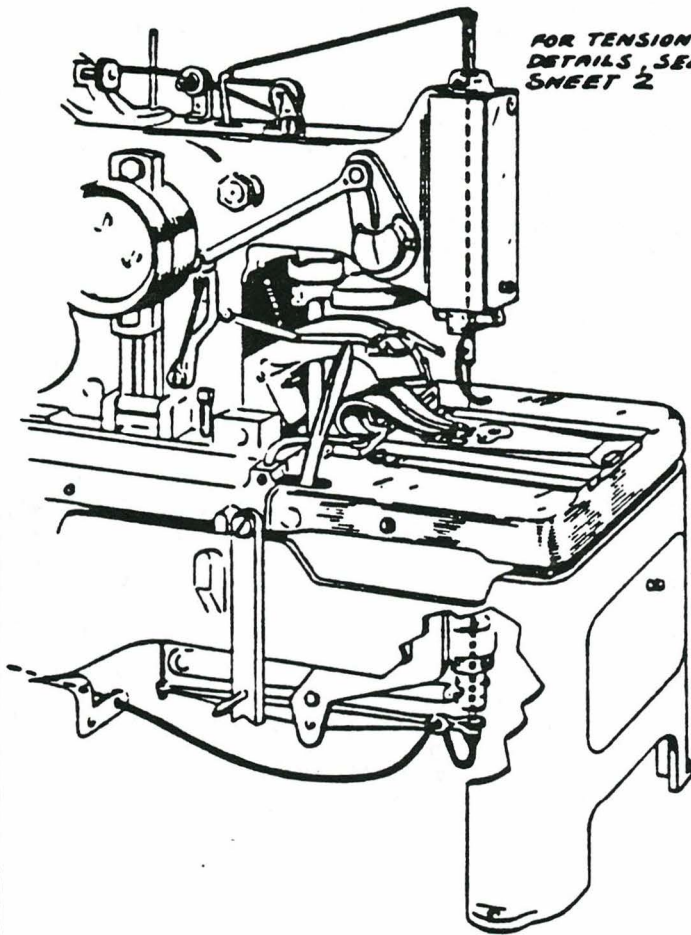
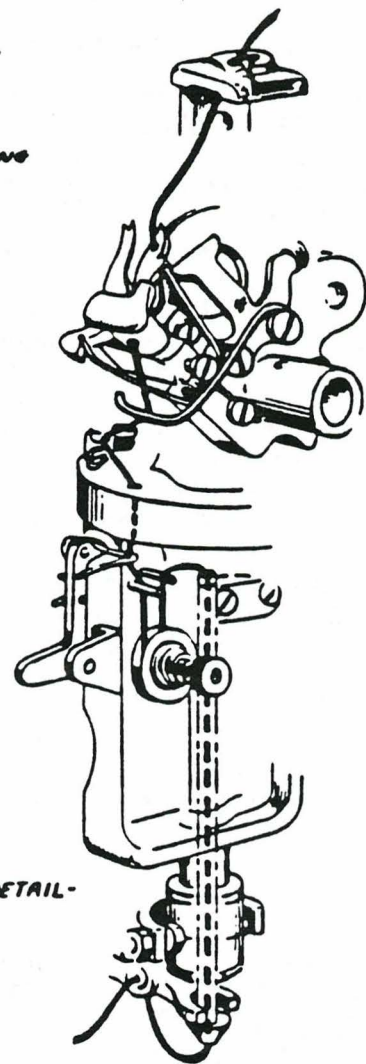

FIG.2

- CORD TRIM -  
THREADING DIAGRAMS



FOR TENSION THREADING  
DETAILS, SEE  
SHEET 2



-DETAIL-

CORD THREADING DIAGRAM

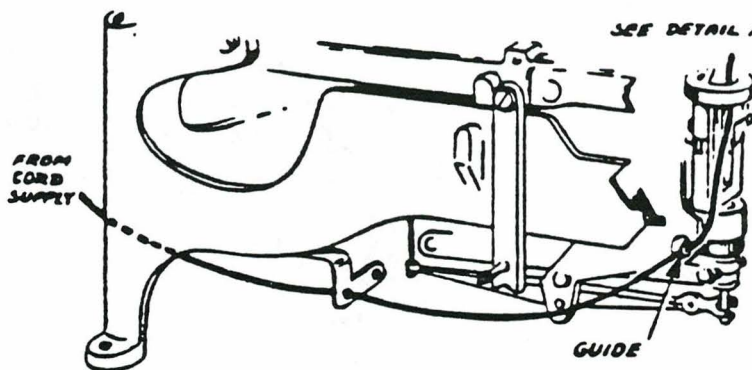

SEE DETAIL AT RIGHT

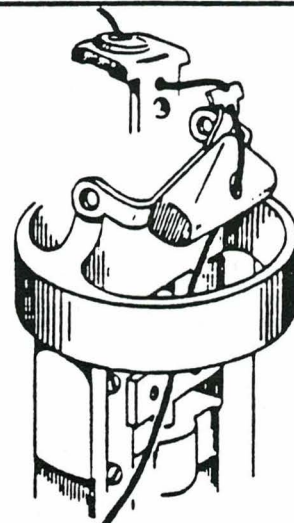

CRANK MACHINE UNTIL RACE  
FACES AS SHOWN ABOVE.



**CORD TRIM**

**MODEL 101 MACHINE ADJUSTMENT**

**CORRECTIVE AND MAINTENANCE-CONTINUED-**

**- UPPER THREAD DRAW OFF AND TENSION ADJUSTMENTS -**

KEEP TENSION (A) TIGHT ENOUGH TO BREAK THE UPPER THREAD AT THE LAST STITCH. MAKE SURE THAT LEVER (B) RELEASES TENSION (A) WHEN THE MACHINE STARTS SEWING, SO THAT ONLY TENSION (C) WILL BE EFFECTIVE DURING THE SEWING CYCLE. THIS TENSION SHOULD SWING IN THE DIRECTION OF ARROW (Y) WHEN THE MACHINE REACHES THE FAR END OF ITS TRAVEL AND IN THE DIRECTION OF ARROW (X) JUST BEFORE THE MACHINE STOPS.

TO OBTAIN MAXIMUM LENGTH OF STARTING THREAD AT (J) PROCEED AS FOLLOWS: MAKE SURE MACHINE IS IN ITS NORMAL STOPPING POSITION. LOOSEN SCREWS (F) AND (G) AND ROTATE CAM (H) TO THE POINT WHERE PIN (D) IS AT THE BOTTOM OF THE CAM DROP AT (E) AS SHOWN FIG. 1. THEN TIGHTEN SCREWS (F) AND (G) SECURELY.

TO DECREASE THE LENGTH OF STARTING THREAD AT (J) ADJUST THE POSITION OF CAM (H) AS REQUIRED IN THE DIRECTION OF ARROW MARKED LESS, FIG. 1.

NOTE - FOR MACHINES EQUIPPED WITH NEEDLE BAR TYPE UPPER THREAD DRAW OFF; SEE SHEET 20.

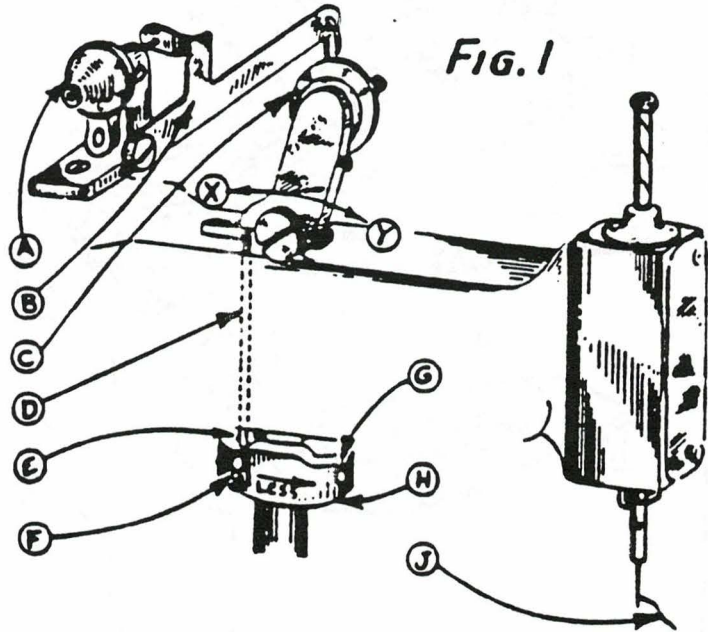

FIG. 1

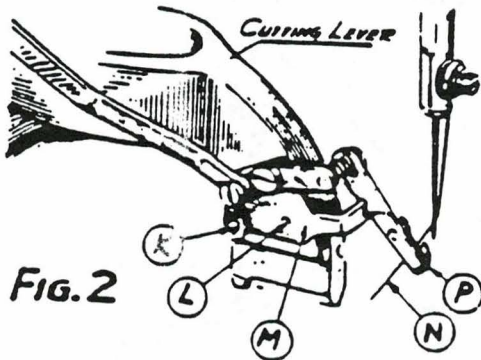

FIG. 2

**THREAD PICK-UP ADJUSTMENT**

THE PICK-UP HOOK (P) FIG. 2, DIPS WITH THE CUTTING LEVER AND GRASPS THE UPPER THREAD AND HOLDS IT OUT OF THE WAY FOR THE NEXT BUTTON HOLE. - THE EXTENT OF THE DIP DOWNWARD SO THAT IT WILL NOT MISS THE THREAD (N) IS ADJUSTED BY LOOSENING THE SCREW (K) AND SWINGING THE PLATE (M) UPON ITS FULCRUM PIN (L) AS DESIRED.

**UNDER THREAD DRAW-OFF AND TENSION RELEASE**

TO PROVIDE MORE OR LESS THREAD, LOOSEN NUT (Q) AND ADJUST STUD (R) UP OR DOWN TO SUIT.

TIGHTEN NUT (Q) SECURELY.

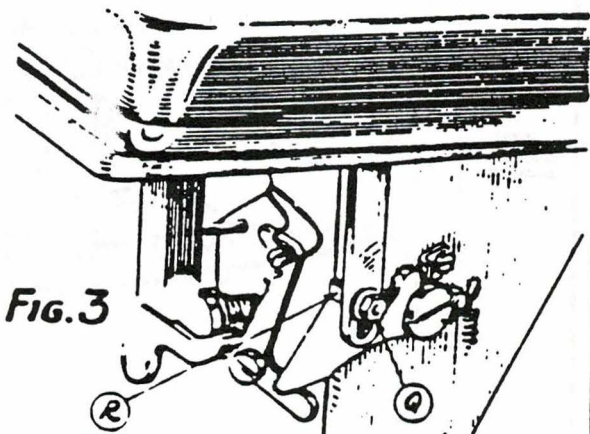

FIG. 3

CORD TRIM

MODEL 101

THREAD TRIMMER AND THREAD RETAINER

UPPER THREAD TRIMMER IS ACTIVATED BY A WEDGE LOCATED ON THE MAIN CAM. MOVEMENT OF THE THREAD TRIMMER SHOULD BE DELAYED AS LATE AS POSSIBLE TO ALLOW THREAD PICKUP HOOK TO BE IN POSITION, TO PICKUP TRIMMED THREAD.

KNIFE SHOULD BE SET TO CLEAR FRONT OF NEEDLE AND BOTTOM OF THROAT PLATE. ALSO CHECK THAT KNIFE CLEARS TOP OF SPREADER.

KNIFE SHOULD BE INSTALLED AND ADJUSTED SO THAT IT TEARS THREAD ON THE RETURN STROK.

THREAD RETAINER SHOULD BE SET BELOW THE TOP SURFACE OF THE THROAT PLATE AND SET LIGHTLY AGAINST THE FRONT OF THE THROAT PLATE.

THREAD RETAINER IN ITS HOME POS, SHOULD BE TO THE RIGHT OF THE THREAD SLOT. WHEN THE TRIMMER IS ACTIVATED THREAD RETAINER WIPES ACROSS THE THREAD SLOT AND CAPTURES THREAD FOR THE NEXT CYCLE.

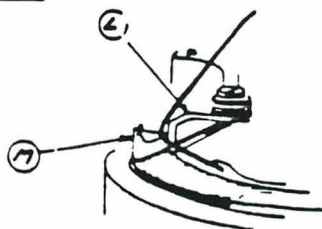
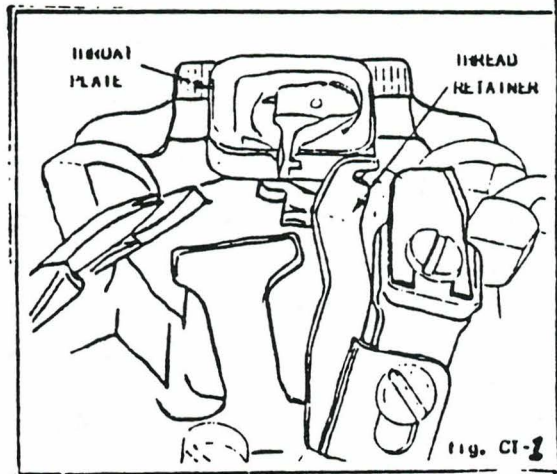

FIG. 3

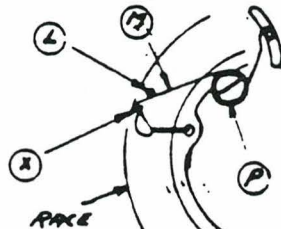

FIG. 4

THE CHECK SPRING (M) ON THE TOP OF THE RACE IS ADJUSTABLE AS TO SWING OUT AND IN; LOOSEN SCREW (P) AND ADJUST THE STOP WIRE (L)

THE APPROX. CORRECT POSITION IS AS SHOWN IN FIG. 4 AT (X) (AT EDGE OF MACHINED PORTION OF CAM CASE)

TO SET THE UNDER THREAD GUIDE

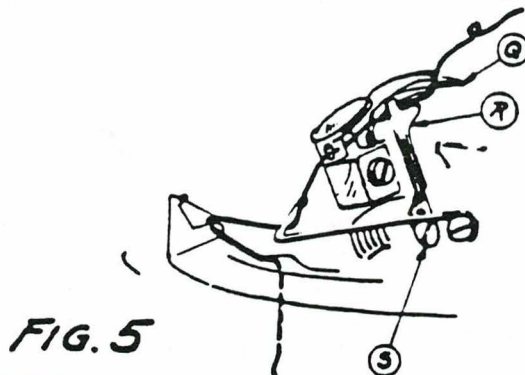

FIG. 5

ADJUST THE UNDER THREAD GUIDE (R) SO THAT THREAD LIES CLOSE TO THE UNDER SIDE OF THE LOOPER (Q) AND THREAD RUNS FREELY WITHOUT FRICTION - USE SCREW (S) TO ADJUST.

**CORD TRIM**

**MODEL 101 - MACHINE ADJUSTMENT**  
CORRECTIVE AND MAINTENANCE - CONTINUED -

**THEORY AND ADJUSTMENT TO INSURE PROPER FUNCTIONING OF CORD**

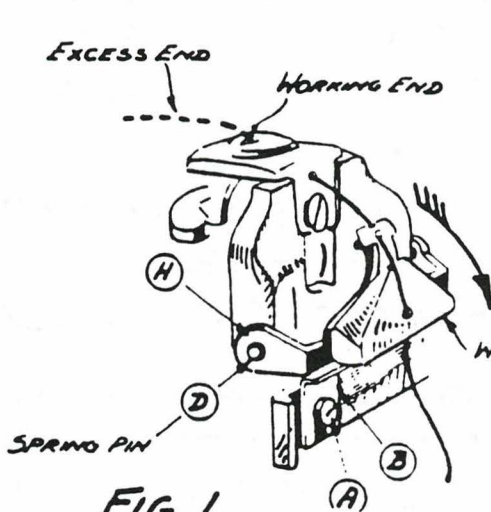

**FIG. 1**

THE DROP OF THIS CORD PULL BAR IS ADJUSTED BY LOOSENING SCREW (A) AND ADJUSTING THE STOP (B) TO SUIT.

(SPRING (G), IN FIG. 2, ACTS BOTH AS A CLAMP AND A TENSION ON CORD) - TO ADJUST - THE YOKE (H) IS TAKEN OFF THE RACE BY PRESSING INWARD THE PLUNGER (D) AND ADJUSTING WITH SCREW (F). WHEN PROPER ADJUSTMENT IS MADE - CORD CAN NOT BE DRAWN BACKWARD.

ADJUST SLIGHTLY UNDER TOP OF HOLE

TO ADJUST FOR TENSION - ADJUST SPRING (G) WITH SCREW (F) UNTIL THERE IS SUFFICIENT FRICTION ON CORD TO LIFT WEIGHT UPWARD TO CONTACT THROAT PLATE.

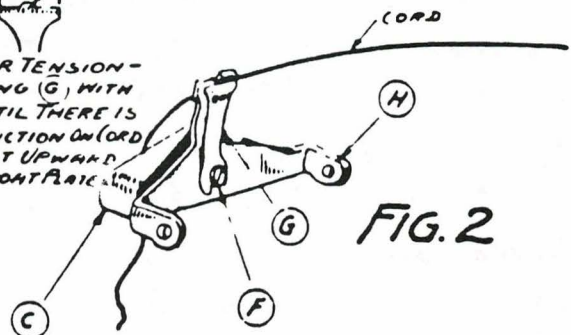

**FIG. 2**

**SHEAR ADJUSTMENT**

**FIG. 3**

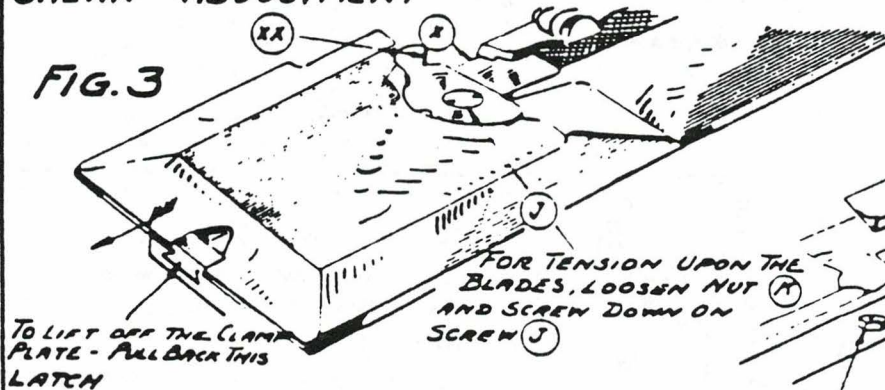

TO LIFT OFF THE CLAMP PLATE - PULL BACK THIS LATCH

FOR TENSION UPON THE BLADES, LOOSEN NUT (A) AND SCREW DOWN ON SCREW (J)

DO NOT SHARPEN BLADES FROM THE TOP OR FLATS. STONE THE EDGES ONLY AT (X) AND (XX)

SHOWING UNDER SIDE OF CLAMP PLATE

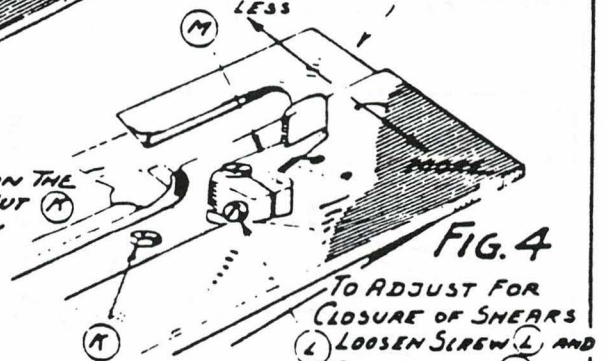
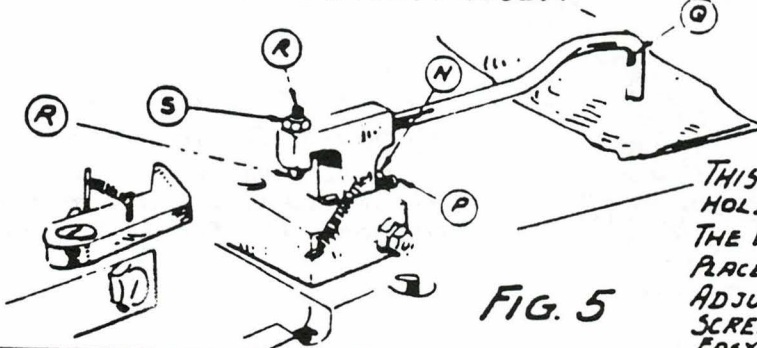

**FIG. 4**

TO ADJUST FOR CLOSURE OF SHEARS - LOOSEN SCREW (L) AND SWING LEVER (M)

**TO ADJUST THE HOLD DOWN FINGER**

NOTE THIS FINGER HAS BEEN SUPPLIED WITH AN ADJUSTABLE SCREW (A) TO ADJUST LOOSEN NUT (S) TURN SCREW (A) TO SUIT AND LOCK WITH NUT (S) AFTER OBTAINING DESIRED PRESSURE OF FINGER ON WORK.



**FIG. 5**

THIS MACHINE IS SUPPLIED WITH A HOLD DOWN FINGER (Q) FOR HOLDING THE WORK WHILE CUTTING OF THREAD TAKES PLACE AND REGULAR CLAMP ARMS ARE UP. ADJUST BY LOOSENING NUT (N) AND ADJUST SCREW (P), FOR PROPER CLEARANCE AND EASY INSERTION OF WORK.



MODEL 101

ADJUSTMENTS FOR THE  
ADJUSTABLE FLY BAR MACHINE

TO ADJUST FOR LENGTH OF BUTTON HOLE - LOOSEN THUMBSCREW (A) AND SET GAUGE POINTER TO ANY GRADUATION DESIRED; AND CHANGE CUTTING STEEL TO CONFORM.

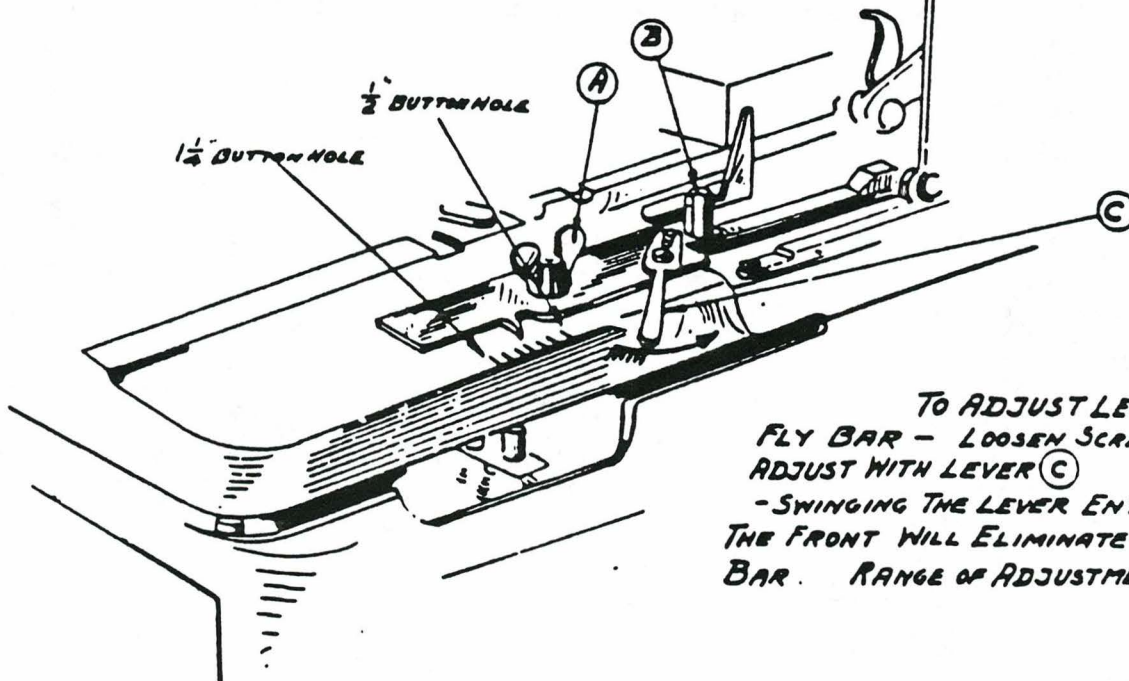

TO ADJUST LENGTH OF FLY BAR - LOOSEN SCREW (B) AND ADJUST WITH LEVER (C) - SWINGING THE LEVER ENTIRELY TO THE FRONT WILL ELIMINATE THE FLY BAR. RANGE OF ADJUSTMENT IS 0 TO  $\frac{3}{8}$ "

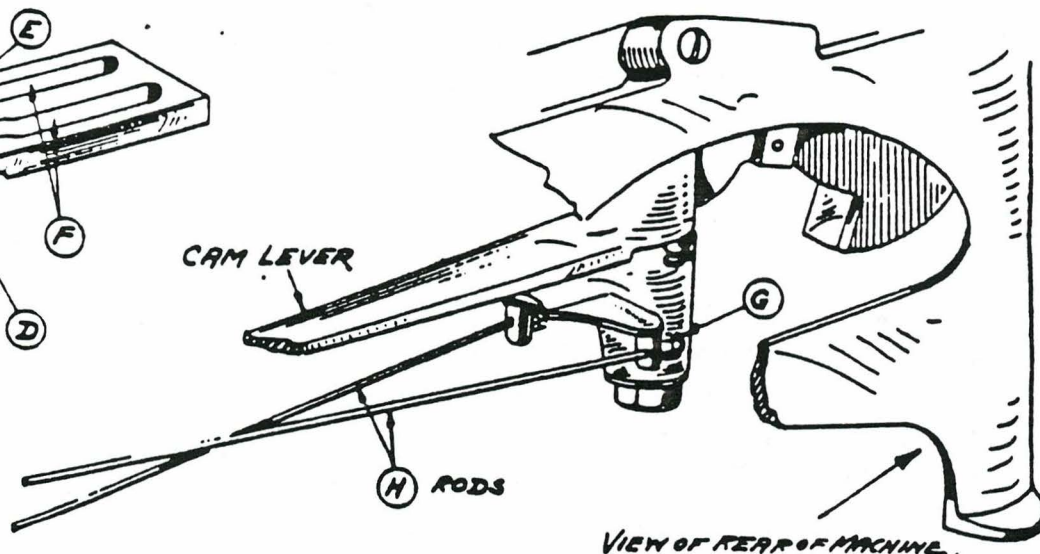
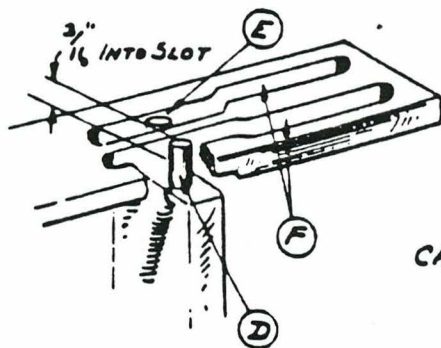

NOTE  
THE PLUNGERS (D) AND (E) SHOULD ENTER THE SLOTS (F) ABOUT  $\frac{3}{16}$ " - TO ADJUST THIS DEPTH TAKE UP OR LET OUT WITH NUTS (G) ON RODS (H)

**MODEL 101**

**ADJUSTMENTS FOR THE ADJUSTABLE FLY BAR MACHINE**

TO ADJUST FOR PROPER FUNCTIONING-TIP THE MACHINE TO A VERTICAL POSITION UPON ITS BASE-CRANK THE MACHINE WITH THE L.H. HANDWHEEL UNTIL THE ROLL (A) IS AT THE PEAK OF THE CAM AS SHOWN

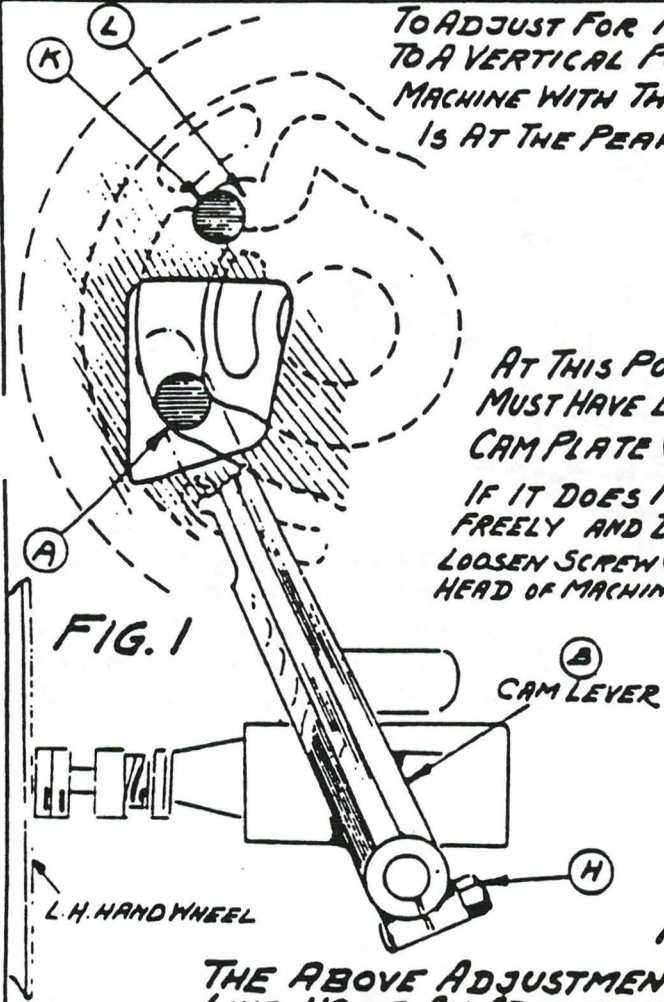

**FIG. 1**

AT THIS POINT PLUNGER (E) MUST HAVE ENTERED SLOT (F) IN CAM PLATE (G)

IF IT DOES NOT ENTER FREELY AND DEFINITELY - LOOSEN SCREW (H) AND TRAP HEAD OF MACHINE (J) TO SUIT

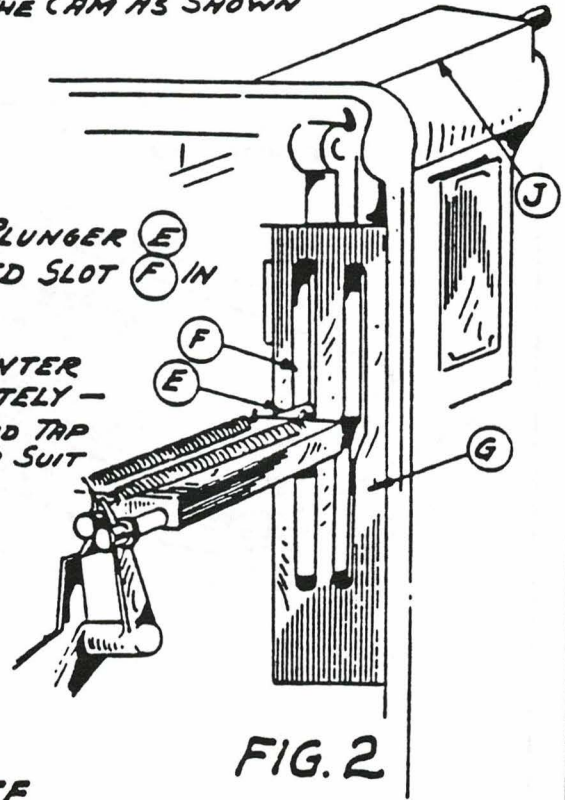
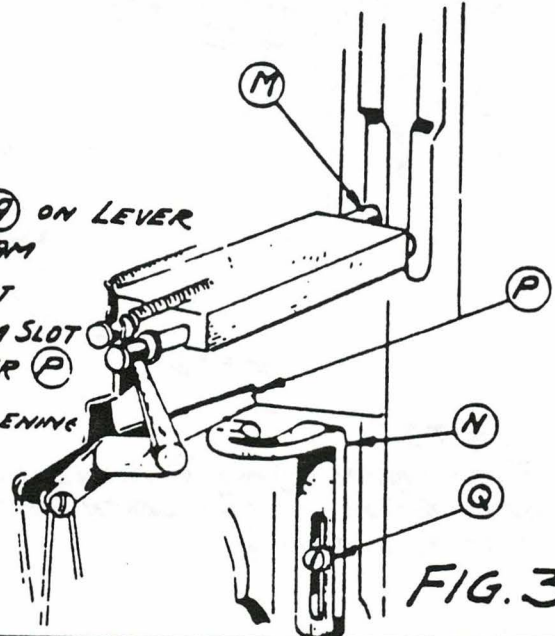

**FIG. 2**

**NOTE**

THE ABOVE ADJUSTMENT CONSTITUTES THE LINE UP OF AN ADJUSTABLE FLY BAR MACHINE

CRANK THE MACHINE UNTIL THE ROLL (A) ON LEVER (B) IS AGAIN DEFINITELY EMBRACED BY CAM PATH (L) ON THE CAM AT (K) FIG. 1-AT THIS POINT PLUNGER (M) SHOULD HAVE JUST WITHDRAWN FROM SLOT BY ACTION OF BRACKET (N) AGAINST LEVER (P) IF NOT, ADJUST BRACKET (N) TO SUIT BY LOOSENING SCREW (Q)



**FIG. 3**

# MODEL-101 CUT BEFORE EDGING MACHINES

## UPPER THREAD DRAW-OFF AND TENSION DETAILS

Keep Tension (A) tight enough to break the upper thread at the last stitch, and to prevent thread from being drawn from the source of supply through the needle as the garment is removed from the machine. Make sure that Lever (B) releases Tension (A) when machine starts sewing, so that only Tension (C) will be effective during the sewing cycle.

The required length of Starting Thread at (J) is provided by the movement of Upper Thread draw-off Tension (C). This Tension should swing in the direction indicated by arrow (X) immediately after the machine starts, and in the direction of arrow (Y) when the machine is at the far end of its travel.

### Adjustment of Upper Thread Draw-Off

To obtain maximum length of Starting Thread at (J), proceed as follows:

Make sure machine is in its normal stopping position. Loosen screws (F) and (G) and rotate Cam (H) to the point where Pin (D) is at the very top of the Cam rise at (E) as shown Fig. 1. Then tighten screws (F) and (G) securely.

To decrease the length of Starting Thread at (J) adjust the position of Cam (H) as required in the direction of arrow marked Less Fig. 1.

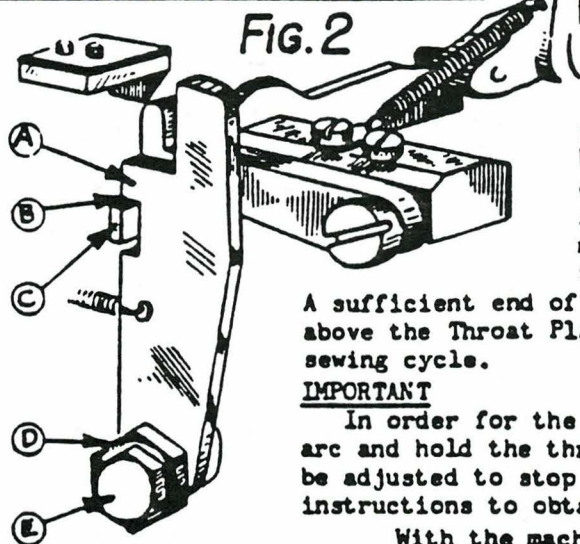
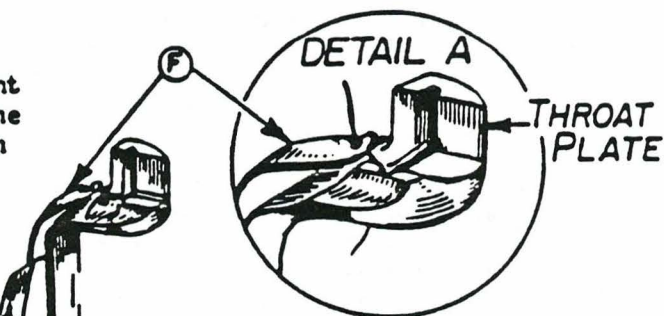
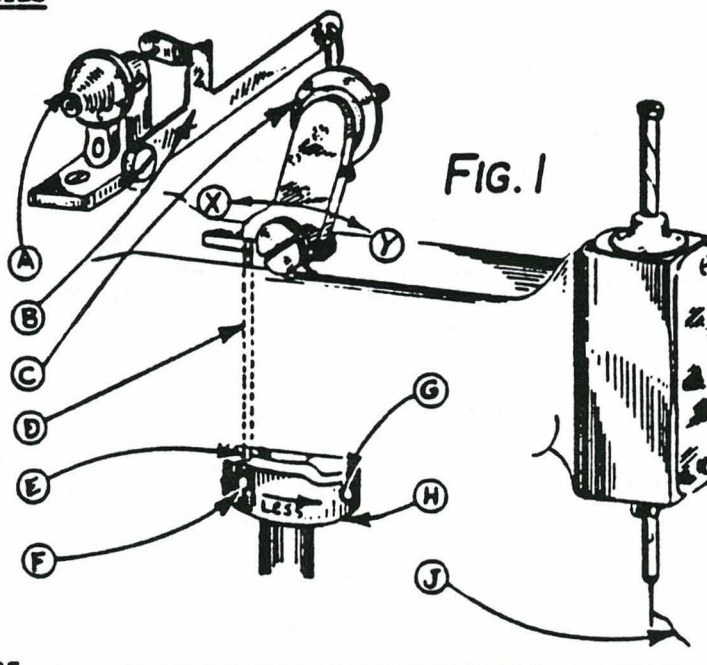

### OPERATION OF UNDER THREAD GRABBER

Thread Grabber (F), Fig. 2, should be positioned to catch and lightly hold the Under Thread against the back beveled edge of the Throat Plate as the machine stops. A slight tug on the garment as it is removed from the machine will cause the thread to break at the knot of the last stitch.

A sufficient end of the thread will remain held by the Grabber above the Throat Plate as shown in Detail A to start the next sewing cycle.

### IMPORTANT

In order for the Thread Grabber to swing through its full arc and hold the thread as shown Detail A, the machine must be adjusted to stop in its extreme forward position. For instructions to obtain this adjustment refer to Sheet 17, Fig. 1.

With the machine in Stop Position as described above, make sure that Lever (C) is engaged in the notch of Latch (A) with no more than paper thickness clearance existing at point (B). To obtain this clearance loosen screw (E) and turn Eccentric (D) as required. Then tighten Screw (E) securely.

# NEEDLES

Needles for the Reece Series 101 machines are packaged and sold in boxes of 100, in the sizes and types listed. They are of superior struck groove construction, chrome plated and are spotted at the eye except in size 00 and finer. When ordering, specify quantity - - (100, 200 etc.) and give the Needle E.D.P. Number.

TYPE	APPLICATION	E.D.P. NUMBER	CODE NUMBER	NEEDLE BLADE SIZE
ROUND POINT LONG SHANK	Applicable to the majority of woven fabrics, knits and other materials of similar consistency. The Long Shank needles have added stiffness in the blade which permits the use of one size smaller needle than would be normally required. Long Shank needles can not be used on heavy material that would be penetrated by the tapered portion of the needle shank.	02-0500-1-000 02-0500-1-100 02-0501-1-110	500-LS-000 500-LS-00 501-LS-0	Extra Fine Very Fine Fine
ROUND POINT		02-0501-0-111 02-0501-0-112 02-0501-0-113	501-1 501-2 501-3	Medium Heavy Very Heavy
ROUND POINT BALL EYE	Applicable to closely woven fabrics or where sewing is over heavy seams, particularly in cottons. In sewing, the Ball Eye produces a hole in the fabric slightly in excess of the needle blade diameter, thereby reducing needle heating below that of a needle with uniform blade diameter.	02-0502-0-111 02-0502-0-112 02-0502-0-113	502-1 502-2 502-3	Medium Heavy Very Heavy
ROUND POINT DOUBLE GROOVE	The Double Groove needle should be used only when conditions justify it because it casts a smaller loop than standard needles and may introduce skipping. For this reason looper points should be set close to needle blade. This needle is used on materials having a tendency to trap the thread in its descent into the work which affects the thread takeup, or causes the thread to break at the needle's eye.	02-0503-0-111 02-0503-0-112 02-0503-0-113	503-1-DG 503-2-DG 503-3-DG	Medium Heavy Very Heavy
EXTRA LONG POINT BALL EYE	Applicable to fabrics which offer high resistance to needle penetration. Also recommended in cases where fast timing of the loopers is necessary. This needle differs from the 501 type needle only in length from the eye to the point.	02-0504-0-111 02-0504-0-112 02-0504-0-113	504-1 504-2 504-3	Medium Heavy Very Heavy
BALL POINT LONG SHANK	Applicable to synthetic fabrics, particularly of the tightly woven or tightly knitted types where the fibers of the material are subject to damage by conventional sharp pointed needles. The Long Shank needles of this type have the advantages stated above for Round Point Long Shank needles.	02-0505-1-100 02-0505-1-110	505-LS-00 505-LS-0	Very Fine Fine
BALL POINT		02-0505-0-111	505-1	Medium
ROCKED POINT BALL EYE	Applicable to leather and similar materials where conventional sharp pointed needles tend to leave excessive punctures. The split made by Rocked Point needles in leather will tend to close up after penetration. This needle permits a higher stitch density than is possible in leather with a Round Point needle.	02-0506-0-111 02-0506-0-112 02-0506-0-113 02-0506-0-114	506-1 506-2 506-3 506-4	Medium Heavy Very Heavy Extra Heavy
SPEAR POINT	Applicable to fabrics containing a high percentage of starch or similar substances which tend to cause needle heating or resistance to proper pulling up of the stitches.	02-0508-0-111 02-0508-0-112 02-0508-0-113	508-1 508-2 508-3	Medium Heavy Very Heavy

## **TROUBLE DIGEST**

The object of this Digest is to make available to the users of Reece Series 101 buttonhole machines information that will aid them in locating troubles and the proper procedure to remedy them.

### **PRELIMINARY REMARKS**

Reece Buttonhole Machines are of the fully automatic, heavy duty type for industrial use. They are built in a complete line of "Cut Before" and "Cut After" models with operating cycles as described below:

#### **Operating cycle of Cut Before models:**

When starting lever is depressed, the machine automatically: 1. Clamps the material and cuts the buttonhole. 2. Moves rapidly to stitching position by drive from the Left Hand Pulley and spreads the material on the way. 3. Transfers the drive to the Right Hand or Stitching Pulley and stitches the buttonhole. 4. Transfers the drive to the Left Hand Pulley and moves rapidly to stop position, unclamping the material.

#### **Operating cycle of Cut After models:**

When starting lever is depressed, the machine automatically: 1. Clamps the material. 2. Moves rapidly to stitching position by drive from Left Hand Pulley and spreads the material on the way. 3. Transfers the drive to the Right Hand or Stitching Pulley and stitches the buttonhole. 4. Transfers the drive to the Left Hand Pulley and rapidly moves to cutting position where the buttonhole is cut, and then to stop position where the material is unclamped.

**IMPORTANT** — Do not disturb an adjustment unless you know why the change is made and the result that it will produce. Note how to restore an adjustment to its original setting.

The headings indicate the type of trouble. Below them will be found the probable cause for the trouble and its remedy. Machine failure as indicated by the heading can be traced to one or more of the causes beneath it.

**1. MACHINE FAILS TO START:**

- A* See that the Belts are on properly and power is applied.
- B* If Belts and Pulleys leading from Transmitter are not turning over, but the Center Pulley of the Transmitter is, there may be slipping in the Clutch. Adjust two Screws 01-2065 on Clutch Shoe 02-0526-0-050 inward an equal amount.
- C* If the Belts are turning and Left Wheel Dog 10-3042-2 will not engage Striker 10-3038-1 on Crank, Spring on Shifting Lever 10-3029-1 may be weak, off or broken. **REPLACE.**
- D* Lock Nuts 10-3041 on Left Hand Wheel may have loosened. Screw in and adjust so that Dog 10-3042 has no side play and works freely.
- E* Striker 10-3038 may be broken. **REPLACE.**
- F* Clamp Screw 01-2035 on Shifter Spool 10-3045 may be loose. Adjust and tighten according to instructions under machine adjustments, Sheet 16, Fig. 4-5.

**2. MACHINE STARTED, RAN A SHORT DISTANCE AND STOPPED:**

- A* It would be advisable to first check all items under No. 1.
- B* Left Hand Wheel Belt too loose. **TIGHTEN.**
- C* On Cut Before machines, the pressure on the Cutting Lever is too great. Adjust according to instructions on Sheet 12, Fig. 3.
- D* The line-up may have shifted. Follow instructions on Sheet 1, Fig. 2-3.
- E* Rocker Arm may be out of adjustment. Follow instructions on Sheet 14, Fig. 5-6, Sheet 15, Fig. 1A-2A-3A and Sheet 16, Fig. 4-5.
- F* Spring 01-5450 on Clutch 10-1089 may be broken. **REPLACE.**
- G* Pin in Drive Cam 10-1095-3 may be broken. **REPLACE** Drive Cam 10-1095-3.
- H* Sector teeth may be clogged with dirt. Take out Stud 10-3026 and test by rotating the whole assembly back and forth.

**3. MACHINE STUCK TIGHT THROUGH INTERFERENCE:**

- A* Separate the stitching mechanism from the feeding mechanism by removing Shoulder Screw 01-1132. If the interference is in the stitching mechanism the Stop Wheel 10-1088-0-050 on the right hand side will not turn after it is unlocked. Trace for the cause in the stitching mechanism by taking out Screw 10-3008, which disconnects Loooper Drag Link 10-1067 from Loooper Rocker 10-3006-0-165 or 10-3006-0-200. This will definitely place where the sticking occurs, either in the Race assembly or in the Head.
- B* If the Stop Wheel 10-1088-0-050 does turn after the Shoulder Screw 10-1111 is removed, crank the machine with the Left Hand Handle and, if it still will not move, eliminate the probable possibilities for the sticking by disconnecting the units depending on movement from the Main Cam. If the Main Cam will not move after working the Handle back and forth, it will be necessary to take out the Main Cam to remove the interference; unless, it may be removed through one of the various openings in the Cam Case.

**4. STITCHING OPERATION FAILS TO START OR HAS STARTED AND STOPPED:**

- A* Right Hand Belt on wrong.
- B* Spring 01-5450 off or broken. **REPLACE.**
- C* Pin in Drive Cam 10-1095-3 broken. **REPLACE** Driver Cam 10-1095-3.
- D* Pivot of Clutch 10-1089 not working freely in hole of Stop Wheel 10-1088-0-050. Smooth Pivot and clean hole in Stop Wheel.
- E* Pivot of Clutch 10-1089 broken. **REPLACE.**
- F* Set Screw in Feed Cam 10-1093 worked out. Screw in tightly.
- G* Spring 01-5088 on Trip Lever 10-1124 broken. **REPLACE.**
- H* Trip Lever out of adjustment. Adjust according to instructions on Sheet 15, Fig. 3A.
- I* Dog 10-1117 slipped. Reset squarely and tighten.

- J* Stitching mechanism stuck through interference. Follow instructions under heading (3) A-B.
- K* Check stop motion adjustments on Sheet 14, Fig. 5-6, Sheet 15, Fig. 1A-2A-3A and Sheet 16, Fig. 1-2-3-4-5.

### **5. FEEDING UNEVEN:**

- A* Belts leading from Transmitter to machine either too tight or loose.
- B* Belt from Main Shaft to Transmitter slipping. Shorten Belt.
- C* Clutch on Transmitter slipping. Adjust the two Screws 01-2065 on Clutch Shoe 04-0526-0-050 inward an equal amount.
- D* Left Wheel does not run freely on Worm Shaft. Oil thoroughly through hole in Crank 10-3037-1.
- E* Transmitter may not be set close enough to the Main Shaft, causing Belts to tighten unduly when the machine feeds away from operator. This will cause racing of the machine when it feeds towards the operator. Reset Transmitter inward so that belt angle from vertical is not pronounced on the left side.
- F* Friction on Main Cam either too tight or loose. Adjust according to instructions on Sheet 17, Fig. 3.
- G* Friction Collar 10-3046 improperly set. See Sheet 17, Fig. 2, for adjusting instructions. Compression on this Collar can be fairly complete.
- H* Teeth in Ratchet 10-3048 worn. REPLACE.
- I* Pawls 10-3052 worn or sticking. Refit or replace.
- J* Pawl Springs 01-5018 weak or broken. REPLACE.
- K* Left Hand Wheel adjustment in relation to Rocker Shaft assembly improper. Adjust according to instructions on Sheet 14, Fig. 5-6, Sheet 15, Fig. 1A-2A-3A and Sheet 16, Fig. 4-5.

### **6. MACHINE TURNING HARD AT EYE:**

- A* Dirt lodged between Upper and Lower Sector Teeth. Clean out.
- B* Adjusting Collar 10-4023 set up too tight. Ease off slightly.

### **7. STOP MOTION OF STITCHING MECHANISM DOES NOT STOP PROPERLY:**

- A* Check adjustments in their order on Sheet 14, Fig. 5-6, Sheet 15, Fig. 1A-2A-3A and Sheet 16, Fig. 1-2-3-4-5.
- B* Spring 01-5013 too weak or broken. REPLACE.
- C* Rocker Shaft 10-1093 binding in Head Casting. Free it.
- D* Too much side play in Rocker assembly. Take out according to instructions on Sheet 15, Fig. 3A. (See note at bottom of Sheet 15.)
- E* Lever 10-1085 not functioning properly. Turn the Left Hand Crank Handle until Rocking Lever 10-1098-1-050 moves as far back as it will go and has slightly advanced. Adjust the Lever 10-1085 so that it will show a clearance between its end and the Dog 10-1102-1. When it is working properly the Lever 10-1085 will move up and down on the Cam of the Stop Wheel 10-1088 during the stitching operation and will prevent the forward motion of the Rocking Lever and Bolt 10-1099 until the contact end of Clutch 10-1089 has passed the contact end of the Bolt.
- F* Cushion Spring 01-5009 in Stitch Pulley 10-1094-3-050 broken. REPLACE.
- G* Roll 01-7002 or Stud 01-6350 loose or broken. REPLACE.

### **8. NOISE IN STOP MOTION:**

- A* The Right Hand Belt on wrong.
- B* Latch Spring 01-5011 broken. REPLACE.
- C* Latch 10-1100 out of adjustment. Adjust according to instructions on Sheet 16.
- D* Pin in Drive Cam 10-1095-3 broken. Replace Drive Cam 10-1095-3.
- E* Spring 01-5450 off or broken. REPLACE.
- F* Stop motion out of adjustment. Follow instructions on Sheet 14, Fig. 5-6, Sheet 15, Fig. 1A-2A-3A and Sheet 16, Fig. 1-2-3-4-5.

### **9. CUTTING LEVER STICKING:**

- A* Left Hand Belt too loose. Transmitter Belt Too loose. Shorten.
- B* Pressure on Cutting Lever too great. Adjust according to instructions on Sheet 12, Fig. 3.

## TROUBLE DIGEST

Page 4

### 10. MACHINE DOES NOT STOP AT ITS MOST FORWARD POSITION OR THERE IS A CLICKING NOISE AT THE FINISH OF CYCLE:

- A Left Hand Belt too tight.
- B Check stopping adjustment according to instructions on Sheet 17, Fig. 1.
- C Dog 10-3042 and Striker 10-3038-1 are either loose, worn or broken. REPLACE.
- D Too much friction on Main Cam. Adjust according to instructions on Sheet 17, Fig. 3.
- E Transmitter out of alignment. Align.

### 11. MACHINE REPEATS CYCLE:

- A Check stopping adjustment according to instructions on Sheet 17, Fig. 1.
- B Screw 01-2071 backed out. Screw in.
- C Spring 01-5019 weak or broken. REPLACE.
- D Spring 01-5020 weak or broken. REPLACE.

### 12. MACHINE COMPLETES FULL CYCLE BUT DOES NOT STITCH:

- A Bumper 10-2016 out of adjustment. See Sheet 16, Fig. 3.
- B Spring 01-5014 weak or broken. REPLACE.
- C Lever 10-1118 rubbing against Bumper 10-2016. Provide clearance by adjusting Lever 10-1113 so that there is no side play. See note on Sheet 15, Fig. 3A or replace Bumper 10-2016 if bent.
- D If clearance is still insufficient, check up on alignment according to instructions on Sheet 1, Fig. 3.
- E Stop motion out of adjustment. See Sheet 14, Fig. 5-6. Sheet 15, Fig. 1A-2A-3A and Sheet 16, Fig. 1-2-3-4-5.

### 13. MACHINE STITCHES A SHORT DISTANCE AND STOPS. THEN COMPLETES CYCLE:

- A Trip Lever 10-1124 out of adjustment. Adjust according to instructions on Sheet 15, Fig. 3A.
- B Trip Lever Spring 01-5088 broken. REPLACE.

### 14. CLAMPING AND UNCLAMPING:

- A To raise Clamp Arms for more or less clearance.
- B To raise Clamp Arms sooner or later.
- C To apply more or less pressure on Clamp Arms. See Sheet 13, Fig. 2, for adjustment instructions.

### 15. CLAMP PRESSURE UNEVEN OR INSUFFICIENT AFTER ADJUSTMENT:

- A Either Screw 01-2046 holding Bearing 10-2025 is loose. Tighten.
- B Screws 01-2048 or 01-2539 loose or broken. Tighten or replace.
- C Pull-Downs 10-2028-1 and 10-2027-1 broken. REPLACE.
- D Screws 01-2051 holding Block 10-2045 or 10-2049 loose or broken. REPLACE.

### 16. CLAMP SPREADING UNEVEN:

- A Knife Holder 10-3058 or Knife Holder 10-3070 (all) out of center. Align according to instructions on Sheet 12, Fig. 6.
- B Parallel adjustment incorrectly set. Adjust according to instructions on Sheet 13, Fig. 1.
- C Clamp pressure uneven, check instructions under heading (15) of Digest of Troubles.
- D Knife too low. Shim up Knife Holder 10-3058 (all) or 10-3070 so that Knife is not more than 1/32" below level of Clamping Mats.

### 17. MACHINE NOT CUTTING PROPERLY:

- A Cutting Steel needs filing. Resurface and adjust Cutting Pressure according to instructions on Sheet 12, Fig. 3-4.
- B Cutting Steel 10-1069 (all) too low. Replace -see Sheet 12, Fig. 3-4.
- C Knife chipped or broken. REPLACE.
- D Pressure too high or low. Adjust according to instructions on Sheet 12, Fig. 3.  
*If Cutting Block is new and pressure is insufficient to cut, after a reasonable adjustment:*
- E Screw 01-2038 holding Anvil Block may be loose or broken. Tighten or replace.
- F Screws 01-2343 holding Head to Cam Case may be loose or broken. Tighten or replace.

- G Cutting Cam Follower 10-1071-1 may be worn. REPLACE.
- H Cutting Lever 10-1154-0-050 C.B. or Cutting Lever 10-1068-1-050 C.A. cracked or broken. REPLACE.

### 18. CUTTING UNEVENLY:

- A Needle bent. Replace Needle.
- B Cutter not centralized or out of alignment. Follow instructions on Sheet 12.

### 19. CUTTING STITCHES ON A CUT AFTER MACHINE:

- A Follow procedure under heading (18) "Cutting Unevenly."
- B Thread tension too loose. Tighten.
- C Clamps not holding work properly. See heading "Clamping and Unclamping," (14) and (15).
- D Cutter too low. Shim up Knife Holder 10-3058 (all) with Shims 10-3075-1-992, 10-3075-1-993 so that Knife is about 1/32" below the top level of Mats 10-2048 (all) and 10-2044 (all).
- E Bevel sides of Cutting Steel 10-1069 (all) close to the cutting impression.
- F Clamp spreading insufficient. Adjust for more spread—see Sheet 7, Fig. 4.
- G When cutting of stitches takes place on both sides, give more space between right and left banks of stitches, according to instructions on Sheet 7, Fig. 2-3.

### 20. DISTORTION OF EYE:

- A Cord not drawing freely. Check source of trouble and eliminate.
- B Hole in Throat Plate 10-4012 (all) too small. String out hole.
- C Throat Plate 10-4012 (all) too high. Seat it properly.
- D Edge of Throat Plate 10-4012 (all) interfering when stitching around eye. Bevel edge slightly on the stem side.
- E Throat Plate 10-4012 striking Mats 10-2044 (all) or 10-2048 (all) around eye. Make clearance.
- F Knife blunt or too thick. REPLACE.
- G Thread tension not balanced. See Sheet 8, Fig. 3-4.

H Spread on Clamps too large or unequal. Reduce or equalize. See Sheet 7, Fig. 4 and Sheet 13, Fig. 1.

I Stud 10-3020 out of adjustment. See Sheet 14, Fig. 3-4.

J Cutter too low. Shim up Knife Holder 10-3058 (all) with Shims 10-3075-1-992 or 10-3075-1-993 so that Knife is about 1/32" below the top level of Mats 10-2044 (all) and 10-2048 (all).

K Bevel Cutting Steel 10-1069 (all) close to the cutting impression.

L Check race swing for 180° turn as well as squareness. See Sheet 9, Fig. 1 — adjustment 1-2.

### 21. SKIPPING STITCHES:

A Needle bent or incorrectly set. Replace or re-set according to instructions on Sheet 4, Fig. 1.

B Machine not threaded properly. See Sheet 2, for threading instructions.

C Loopers too close or too far away from Needle. Adjust according to instructions on Sheet 11, Fig. 1.

D Loopers not equalized. Adjust according to instructions on Sheet 10, Fig. 1-2-3-4-5.

E Loopers dip across Needle too fast or slow. Adjust according to instructions on Sheet 10, Fig. 6.

F Loopers bent, worn or out of shape. REPLACE.

G Needle Bar too high or too low. Adjust according to instructions on Sheet 11, Fig. 6-7.

H Spreaders out of adjustment. Adjust according to instructions on Sheet 11, Fig. 2-3-4-5.

I Spreaders sticking. Clean shanks—if Spreader Springs 01-5024 or 01-5025 are short or sticking, REPLACE.

J Spreaders too high or too low. Spring the Spreader near the shank upward or downward as required. (Spreader point or fork should ride freely over the top of Looper.)

K Thread loop not passing over the shoulder of Left Hand Looper. Stone corner slightly and buff or replace with new Looper.

**CAUTION**—Do not touch the under surface of Looper with emery cloth or any other abrasive ingredients. Use only the

smoothest stone and on the corner only. Polish by buffing.

- L** Work of a flimsy or rubber nature, adjust Looper-dip to 1/8" instead of 3/32".
- M** Throat Plate 10-4012 (all) bent or hole is too large. REPLACE.
- N** Observe whether Clamp Feet 10-2046-0-750 (to 755) or 10-2050-0-750 (to 755) are holding work firmly. If not, locate trouble and correct.
- O** Clamp Foot 10-2050-0-750 (to 755) and 10-2046-0-750 (to 755) too far away from outside needle stroke. Loosen Screws 01-2051 and adjust Clamp Blocks 10-2045 and 10-2049 inward to suit.
- P** Too much play in Looper Carrier 10-4002 (all). Adjusting Collar 10-4023 too loose. Adjust according to instructions on Sheet 12, Fig. 1.
- Q** Too much play in Looper Carrier 10-4002. Check up on worn parts or Rolls and replace.
- R** Clamp spread insufficient to take up slack in cloth. Adjust according to instructions on Sheet 7, Fig. 4.
- S** Springs 01-5026 weak or broken. REPLACE.
- T** Vibrator Block 10-1026-2 sticking due to extreme pressure of Buttons 10-1025-1 on Needle Bar flats. Locate the cause and remove pressure. Buttons should bear very lightly against the flats.

## **22. SKIPPING AT THE START USUALLY CAUSED BY THE FOLLOWING:**

- A** Fork in Left Spreader not covering hole in Looper.
- B** Right Hand Looper too fast.
- C** Looper-dip too slow or fast.
- D** Loopers too far away from Needle.
- E** Clamp Feet too far away from Needle.
- F** Thread not going over shoulder of the Left Hand Looper. Treatment on any of the previous troubles given under heading "Skipping Stitches."

## **23. SKIPPING AT THE JUNCTION OF THE Y OF THE TAIL BAR:**

- A** Cord very hard and heavy, causing Needle deflection. In this case it is well to speed up slightly the time of the Right Hand Looper across the Needle.

## **24. STITCHES RAVELING BACK AT END OF BUTTON HOLE:**

- A** Release on tension is too great. Bend back end of Release Lever 10-1012-1 to just release.
- B** Right Hand Looper too slow across Needle. Speed it up. See instructions on Sheet 10, Fig. 5, for adjustment.
- C** Right Hand Looper bent, worn or out of shape. REPLACE.
- D** Right Hand Spreader not opening enough. Follow instructions on Sheet 11, Fig. 4-5 for adjustment.
- E** Right Hand Spreader too straight. Curve more or replace.
- F** Hole in Throat Plate too large. Replace Throat Plate.
- G** Skipping the last stitches. Clamps not holding work securely. Follow instructions in Trouble Digest under heading 14-15-16.
- H** Needle penetrating in center of Fly Bar. Close up banks of stitches. See Sheet 7, Fig. 2, for adjustment instructions.

## **25. BREAKING UPPER THREAD:**

- A** Needle bent or incorrectly set. REPLACE or reset according to instructions on Sheet 4, Fig. 1.
- B** Machine not threaded properly. See Sheet 2 for threading instructions.
- C** Follow all instructions for Looper and Spreader adjustments on Sheets 10 and 11.
- D** Tension on upper thread may be tight. Loosen for a minimum pull without affecting stitch. See Sheet 8, Fig. 3-4, for adjustment.
- E** Remove all sharp spots over which the thread leads: The Take-up Lever, the Needle Bar, the Throat Plate, Loopers and Spreaders.
- F** Needle striking edge of Throat Plate. Straighten, clear away interference with emery cloth or replace Throat Plate.

- G Prong of Left Spreader or end of Right Spreader too high or protruding over edge of Loopers. Spring downward, replace and reposition. See Sheet 11, Fig. 2-3-4, for adjustment.
- H Needle striking Clamp Foot 10-2050-0-750 (to 755) or 10-2046-0-750 (to 755). Adjust by loosening Screw 01-2051 and move Clamp Arm outward to suit.
- I Needle eye too small. REPLACE with a larger size Needle.
- J Follow instructions under heading (21) "Skipping Stitches," from A to F.

## 26. THREAD BREAKING AND RUNNING BACK OUT OF NEEDLE BAR:

- A Spring 01-5004 against Tension Discs 01-4039 too weak. REPLACE.
- B Spring 01-5005 on Take-Up Lever 10-1051 broken. REPLACE.
- C Upper Tension set up too tightly. Loosen. See Sheet 8, Fig. 3-4.

## 27. BREAKING UNDER THREAD:

- A Tension on thread too tight. Loosen. See Sheet 8, Fig. 3-4.
- B String out hole in Spreader Stop 10-4007.
- C String out hole in Left Hand Looper.
- D String inside of V in Left Hand Spreader prong.
- E Remove sharp spots in Throat Plate.
- F Smooth sides of Mats 10-2044 (all) and 10-2048 (all).

## 28. BREAKING, BENDING OR HOOKING NEEDLES:

- A Follow instructions in Digest under heading (7) "Stop Motion of Stitching Mechanism Does Not Stop Properly" - A to G.
- B Left Hand Wheel 10-3039 does not run freely on Worm Shaft 10-3047-1-050. Oil thoroughly through hole in Crank Lever 10-3037-1.
- C Needle Bar too high or too low. Adjust according to instructions on Sheet 11, Fig. 6-7.
- D Needle Guard 10-4010-2 too far away from Needle. Spring Guard inward to barely contact Needle when Needle Bar is at its lowest stroke.

E Vibrations of Needle Bar not square with Race 10-4001-1 (all). Adjust according to instructions on Sheet 9, Fig. 3.

F Loopers too close to Needle. Adjust according to instructions on Sheet 11, Fig. 1.

G Needle striking Clamp Feet 10-2050-0-750 (to 755) or 10-2046-0-750 (to 755). Loosen Screws 01-2051 and move Clamp Arm outward to suit.

H Needle striking Mat 10-2048 (all) or 10-2044 (all). Follow instructions in Digest under heading (16) "Clamp Spreading Uneven." If any of the above instructions do not provide proper clearance, file the Mat to clear Needle.

I Roll 01-7002 loose or off Rocking Lever 10-1098-1-050. REPLACE.

J Spreaders out of adjustment. See Sheet 11, Fig. 2-3-4, for adjustment instructions.

K Needle striking edge of Throat Plate. String out Throat Plate or replace.

L Transmitter Pulley on the left side too large. Reduce to  $\frac{1}{2}$ " D smaller than Right Hand Pulley. The Left Transmitter Pulley should never be larger than the right hand one.

M Friction Collar 10-3046 or Brake Band 10-3036 too loose. Adjust according to instructions on Sheet 17, Fig. 2-3.

## 29. CHANGING CHARACTER OF BUTTON HOLE:

A To make the button hole even at the finish, adjust according to instructions on Sheet 14, Fig. 1-2.

B To adjust length of button hole, see Sheet 6, Fig. 1-2, for adjustment instructions.

C To increase or decrease the number of stitches in the entire button hole, see Sheet 8, Fig. 1, for instructions.

D To increase or decrease the number of stitches in the eye of button hole without affecting the sides, see Sheet 8, Fig. 2, for instructions.

E To increase or decrease width of the button hole, see Sheet 7, Fig. 3, for instructions.

F To increase or decrease the amount of material. "Cutting Space," in the center of the button hole on a "Cut After" machine, see Sheet 7, Fig. 1-2 for instructions.

- G To spread the work for more opening in center of button hole slit on a "Cut Before" machine, see Sheet 7, Fig. 4, for instructions.
- H To correct eye distortion, see Trouble Digest under heading (20) "Eye Distortion" from A to L.

### 30. PULLING UP STITCHES:

Results depend very much on the thread used. A coarse and rough thread on certain grades of work produces excessive friction which affects the pulling up of the stitches. Although the purl can be set under these conditions, it is usually accomplished by excessive tension or by the use of needles unnecessarily large. Our experience has taught us that a fairly smooth thread of uniform consistency in either the soft or hard finish will not only give dependable results but will, in the final analysis, prove to be the cheapest.

*Important*—Loopers and Spreaders must be correctly adjusted; check adjustments according to instructions on Sheets 10 and 11.

- A Check the Needle for straightness.
- B Lint or dirt lodged between Tension Disks. Clean out.
- C Balance the tension on threads so that they will give the best results with the lowest tension.
- D Smooth the top lip surface on Throat Plate 10-4012 (all) at the opposite side of cord hole.
- E Upper thread must slide over shoulder of Left Looper freely. Follow instructions under heading (21) "Skipping Stitches" at K and note *Caution*.
- F Either Looper rough or sprung. Polish or replace with new Looper.
- G Spreaders rough or not working evenly. Smooth and adjust according to instructions on Sheet 11, Fig. 2-3-4.

## CORD TRIMMER

This part of the Digest concerns the cord trimmer units and problems peculiar to the Cord Trimming Machine. Troubles on the basic part of this machine, where there is a similarity of parts and functions, should be looked up in the Digest on previous pages.

### Theory and Operation of the Trimming Function

When the stitching of the buttonhole is completed, the Head and Cam Case move forward to cutting position. This forward movement is ample to cause the upper thread to break at the knot of the last stitch. The severed end is then picked up and held by the thread pick up hook actuated by the cutting lever as shown on Sheet 22, Figure 2. It will be noticed that during the sewing cycle the thread tension assembly rocks to the front of the machine and retracts when the machine comes to a full stop. This action provides the desired quantity of upper thread to start the next buttonhole.

In the meantime, as the upper thread is severed at the knot during the Head and Cam Case forward movement to cutting position, the under thread draw off mechanism goes into action as shown on Sheet 22, Figure 3, to draw off a supply of under thread from the source of supply and through the under thread tension. The free under thread thus provided is then drawn through the slot in the Throat Plate by the action of the thread hook, Sheet 23, Figure 1. This action occurs just before the under thread and cord are severed by the trimming shears. The combined actions on the under thread, as outlined, and the extent of these actions assure that a sufficient length of under thread extends through the slot in the Throat Plate, as shown on Sheet 23, Figure 2, for the start of the next buttonhole.

The trimming shears can operate only when the cloth holding members, commonly referred to as clamps, have risen to release the work. Therefore, in order that the work shall remain firmly held in trimming position, the Hold-Down finger shown Sheet 24, Figure 5 is utilized as an auxiliary work holding member. The Hold-Down member is brought into action as the Head and Cam Case are moving forward to cutting position. The trimming shears are then free to operate and no movement of the work can occur to effect the trimming action or nullify the thread draw-off provisions as outlined above.

The trimming shears, which are mounted on the clamps, are actuated by a lever on the race. The trimming occurs as the race rotates just before the machine stops. Only the under thread and cord are trimmed by the shears. The upper thread as had been noted above is not severed by the trimming shears. After the cord has been severed, the excess length of cord is drawn back by the weight mechanism shown Sheet 24, Figure 1, so that only a sufficient end is left protruding through the hole in the Throat Plate to start the next operation.

The operation of the various elements may be observed in slow motion by stopping the machine at the completion of the last stitch and then turning the left hand crank slowly until the machine reaches its normal stopping position.

It is advisable to make sure that the machine is stitching and operating properly before making adjustments to the trimming mechanism.

**1. END OF UPPER THREAD IS INSUFFICIENT FOR A PROPER START:**

- A** Pick-up Hook 10-1207 missing the thread. Felt 10-1213 may need replacing.
- B** Burr on hook of Pick-up Hook 10-1207. Remove burr.
- C** Cutting Lever out of center. Centralize, see Sheet 12, Fig. 2, for adjustment instructions.
- D** Adjust Plate 10-1204 for more dip. See Sheet 22, Fig. 2, for adjustment instructions.
- E** Pick-up Hook 10-1207 broken. **REPLACE.**
- F** Upper Thread Draw-off out of adjustment. See Sheet 22, Fig. 1, for adjustment instructions.
- G** Throat Plate 10-4012-0-013 sharp. Smooth.
- H** Under surface of the right hand portion of the notch in upper Shear Blade 10-2207-0-350 adjacent the cutting edge, is too sharp. Round and smooth this part of Shear Blade edge.

**2. END OF UPPER THREAD TOO LONG:**

- A** Upper Thread Draw-off out of adjustment. See Sheet 22, Fig. 1, for adjustment instructions.

**3. LENGTH OF UNDER THREAD SHORT FOR A PROPER START:**

- A** Check adjustment according to instructions on Sheet 22, Fig. 3, and Sheet 23, Fig. 1-2-3-4-5.
- B** Throat Plate 10-4012-0-013 hurred or sharp. Smooth.
- C** Check Spring 01-5043 too lively. Reduce movement by adjusting Stop Wire 10-4211, inward. See Sheet 23, Fig. 3-4, for adjustment instructions.
- D** Thread Guide 10-4212 not high enough. Adjust according to instructions on Sheet 23, Fig. 5.
- E** Upper Thread Draw-off needs checking. It may not be pulling off enough upper thread, contributing largely to the missing of the under thread. Adjust for more thread according to instructions on Sheet 22, Fig. 1.

- F** Left Looper grooved, bent or too slow. **REPLACE** Looper, or speed up if slow. See Sheet 10, Fig. 5, for adjustment instructions.

**4. UNDER THREAD CREEPING UNDER THE FORK IN SPREADER:**

- A** Left Spreader too high or low. Follow instructions in Trouble Digest under heading (21) "Skipping Stitches" at *J*.
- B** Fork in Left Spreader short. **REPLACE.**
- C** Upper thread not slipping over shoulder on Left Looper fast enough, thus forcing the under thread under the fork of the Left Spreader at the narrow point of Looper. Very important to have the upper thread slide freely on Left Looper. Follow instructions in Trouble Digest under heading (21) "Skipping Stitches" at *K*, and note *Caution*.

**5. END OF CORD TOO LONG FOR START:**

- A** Not enough tension on Clinch Spring 10-4209. Adjust according to instructions on Sheet 24, Fig. 1-2.
- B** Clinch Spring 10-4209 bent. **REPLACE** or bend back; inward or outward as required.
- C** Adjust Stop 10-4220 downward according to instructions on Sheet 24, Fig. 1.
- D** Cord catching under the back of Upper Shear Blade 10-2207-0-350. Clear away interfering portion of Shear.
- E** Side of cord hole in Throat Plate 10-4212 sharp or cord hole too small. String out.

**6. END OF CORD TOO SHORT:**

- A** Adjust Stop 10-4220 upward according to instructions on Sheet 24, Fig. 1.

**7. HOLD-DOWN FINGER 10-2212 NOT HOLDING WORK PROPERLY:**

- A** Too much up and down play in Latch 10-2029. Tighten or **REPLACE** Screw 10-2030.
- B** Hold-down Finger 10-2212 bent upward. **REPLACE** or bend back to hold.

**8. SHEARS NOT CUTTING:**

- A** Dull. Stone edges. See Sheet 24, Fig. 3, for instructions.

- B* Not closing properly. Adjust according to instructions on Sheet 24, Fig. 4.
- C* Shear Blade 10-2207-0-350 or 10-2206 sprung, nicked or worn. **REPLACE** blade.
- D* Tension between blades insufficient. See Sheet 24, Fig. 3, for adjustment instructions.
- E* Spring Washer 01-5062 weak or broken. **REPLACE**.

#### **9. TRIMMING NOT CLOSE ENOUGH:**

- A* Taper Bar too short. Adjust according to instructions on Sheet 6, Fig. 1.
- B* Follow instructions in Cord Trimmer Trouble Digest under heading (5) "End of Cord Too Long for Start." *A* to *E*.
- C* Follow instructions in Cord Trimmer Trouble Digest under heading (8) "Shears Not Cutting." *A* to *E*.
- D* Follow instructions in Cord Trimmer Trouble Digest under heading (7) "Hold-down Finger Not Working Properly." *A* to *B*.
- E* Pulling off too much under thread for start. Cut down on supply. See Sheet 22, Fig. 3 and Sheet 23, Fig. 1-2, for adjustment instructions.

#### **10. WORK BEING DRAWN INTO SHEARS:**

- A* Cord drawing hard or sticking. Trace cause and remedy it.
- B* In order to be doubly sure that the upper thread breaks properly, provision has been made, in case the tension and forward motion of the machine fail, for the upper thread to be placed in the groove of the Throat Plate as well as the under thread, with the result that the Thread Hook 10-4204 when pulling off the slack of the under thread, will put sufficient tension on the upper thread to break it. The Throat Plate slot at entry should be beveled smooth from the bottom side so that the corner of the Throat Plate will not hinder the entrance of the upper thread into the channel. Care should be exercised not to make the channel wider from the top side except slightly rounding the corners, otherwise the cord will interfere.

## NOTES

# CONTENTS

## ADJUSTABLE FLYBAR BUTTONHOLE MODELS

Clamping	2-5
Starting Lever	6
Length Gauge	7
Main Cam & Shifting Lever	8
Rocking & Three Fork Levers	9
Flyover Lever, Stop Wheel & Stitch Pulley	10
Drive Shaft	11
Stitch Feed	12-13
Eye/No-Eye Lateral Lever	14
Combination Lateral Lever	15
Flybar Control	16
Needles	17
Needle Bar Drive	18-19
Needle Bar Vibrator	20-21
Thread Control	22-23
Thread Takeup & Looper Drive	24
Spreader Drive	25
Race	26-27
Looper Carrier	28
Turning Sectors & Levers	29
Upper Thread Trimmer	30-31
Cutting	32-33
Knives & Cutting Steels	34-36

## OPEN END BUTTONHOLE MODELS

Clamping	38
Knife Holder & Tension Release	39
Upper Thread Trimming	40
Combination Lever & No-Eye Attachment	41
Lateral Lever & No-Eye Attachment	42
Parts Special to CB-R-ME	43-44

## HAND HOLE MODELS

Hand Hole Attachments	46-47
Main Cam, Stopping Wedge & Stopping Lever	48

## CUT-BEFORE/CUT-AFTER BUTTONHOLE MODELS

Parts Special to CB/CA	50-51
------------------------	-------

## CORD TRIM & CROSS BAR II MODELS

Thread Control	54
Upper Thread Holder	55

Clamping	56-57
Race	58
Race & Stitch Stopping	59
Race & Knife Holder	60
Main Cam & Upper Thread Trimmer	61
Main Cam	62

## ROUND EYELET MODELS

Clamping	64-65
Needle Bar & Cutting	66
Parts Special to RdE	67
Thread Trimming & Tension	68
Parts Special to RdE	69

## CROSS OVAL MODEL

Clamping	72
Race & Thread Controls	73
Turning & Combination Lever	74
Parts Special to Cross Oval	75

## CUT-BEFORE EDGING MODEL

Clamping	78
Thread Controls	79
Race & Cutting	80
Parts Special to CB-ED-R	81
Thread Controls	82-83
Clamping	84
Trimming & Stop Motion	85
Parts Special to CA-ED	86

## PARTS COMMON TO ALL MODELS

Common Parts	88
Stand & Accessories	89
Thread Stand	90
Main Cam Drive Guards	91
Belt Guards	92
Transmitter Base & Treadle	94
Transmitter	95
Transmitter Pulleys	96
Tools, Supplies & Accessories	97

## PARTS INDEX



## ADJUSTABLE FLYBAR BUTTONHOLE MODELS

DESCRIPTION	PRODUCT CODE NO.
AF-CA-R-RE	10-016
AF-CA-R-RE-MB	10-017
AF-CA-XL-LE	10-019
AF-CB-R-FE	10-022
AF-CB-R-RE	10-023
AF-CB-RL-ME	10-024
AF-CB-RL-LE	10-025
AF-CB-R-ME-LE-HH	10-026

This section contains parts special to Adjustable Flybar models. This section also contains those parts considered basic to all series 101 models. When searching for parts, first refer to that model section. Parts not listed there should be considered basic and will be found in this section.

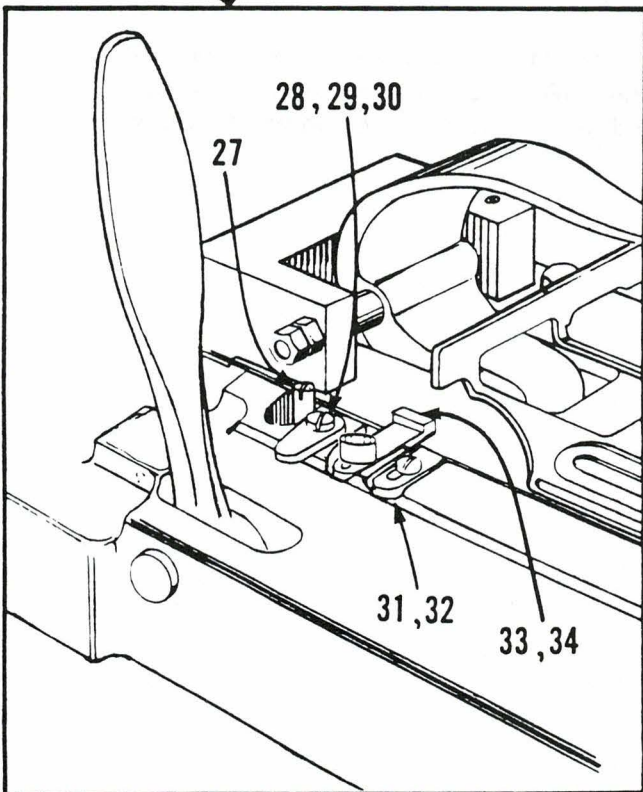
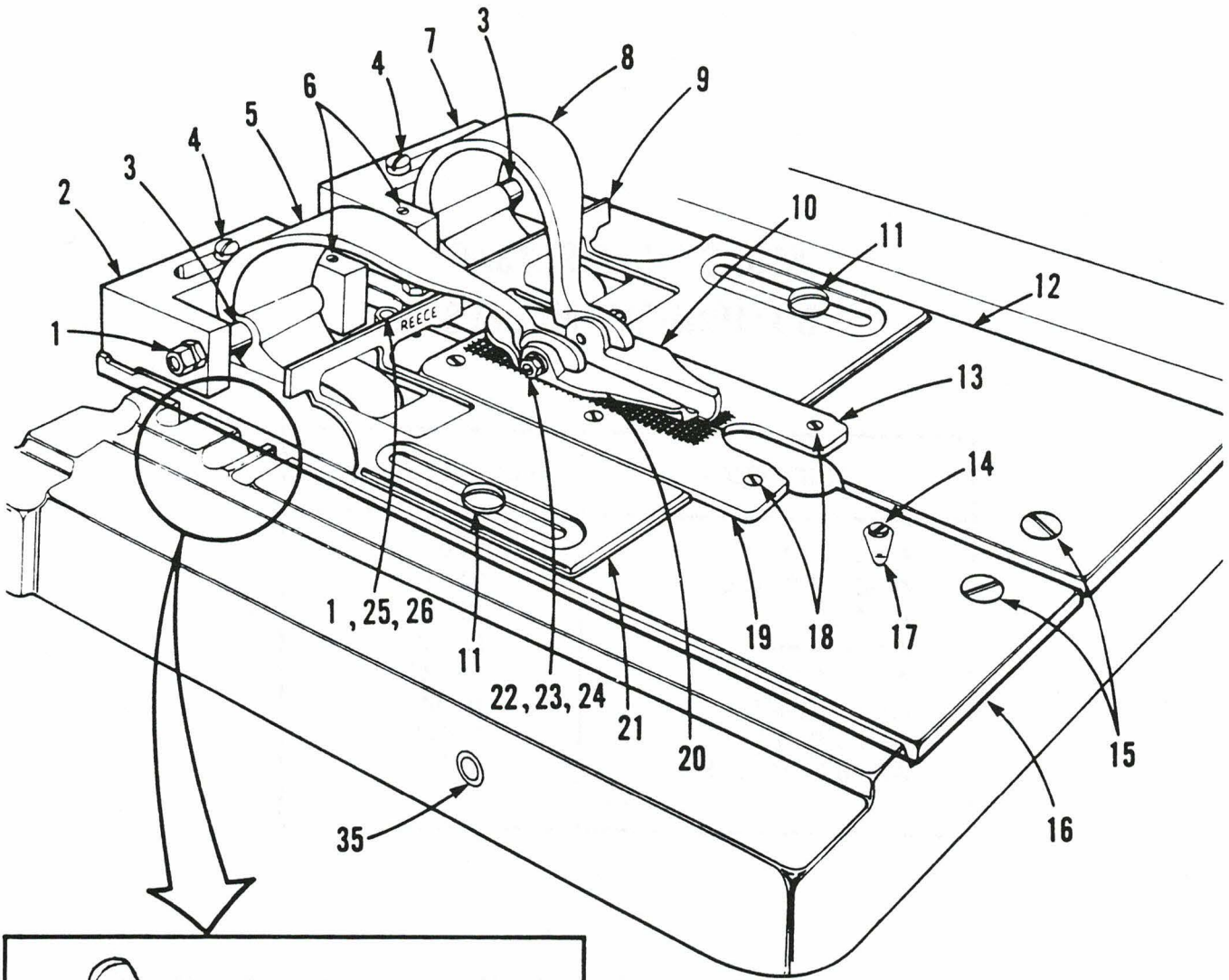

DET.	PART NUMBER	DESCRIPTION
1	01-3001	Nut
2	10-2049	Left Block
3	10-2053	Shaft
4	01-2051	Screw
5	(See Chart)	Left Clamp Arm
6	01-2052	Screw
7	10-2045-1	Right Block
8	(See Chart)	Right Clamp Arm
9	10-2059-1	Cloth Gauge, Right
10	(See Chart)	Right Clamp Foot
11	01-2111	Screw
12	(See Chart)	Right Clamp Plate
13	(See Chart)	Right Clamp Mat
14	01-2053	Screw
15	01-1020-1	Screw

16	(See Chart)	Left Clamp Plate
17	10-2054	Clip
18	01-2015	Screw
19	(See Chart)	Left Clamp Mat
20	(See Chart)	Left Clamp Foot
21	10-2060-1	Cloth Guage, Left
22	01-1137	Screw
23	01-3016	Nut
24	01-4038	Spring Washer
25	10-2051-2	Stud
26	10-2052	Roll
27	10-2042	Screw

28	10-2030	Screw
29	10-2029	Latch
30	01-5022	Spring
31	10-2032	Stop
32	01-2312	Screw
33	10-2031	Slide
34	01-2410	Screw
35	10-2063	Cord Tube

CLAMP PARTS APPLICABLE TO EACH MODEL

STYLE NO.	DESCRIPTION	ARMS		FEET		PLATES		MATS	
		RIGHT 10-2046-	LEFT 10-2050-	RIGHT 10-2046-	LEFT 10-2050-	RIGHT 10-2043-	LEFT 10-2047	RIGHT 10-2044-	LEFT 10-2048-
		⑧	⑤	⑩	⑳	⑫	⑯	⑬	⑰
10-0000-0-016	AF-CA-R-RE**	-2-701	-2-701	-1-751	-1-750	-1-019	-1-019	-0-001	-0-001
10-0000-0-017	AF-CA-R-RE-MB	-2-701	-2-701	-1-751	-1-750	-1-019	-1-019	-0-001	-0-001
10-0000-0-019	AF-CA-XL-LE***	-2-709	-2-708	-1-755	-1-754	-0-017	-0-017	-0-020	-0-019
10-0000-0-022	AF-CB-R-FE**	-2-701	-2-701	-1-751	-1-750	-1-019	-1-019	-0-002	-0-002
10-0000-0-023	AF-CB-R-RE**	-2-701	-2-701	-1-751	-1-750	-1-019	-1-019	-0-002	-0-002
10-0000-0-024	AF-CB-RL-ME***	-2-709	-2-708	-1-755	-1-754	-0-017	-0-017	-0-019	-0-018
10-0000-0-025	AF-CB-RL-LE***	-2-709	-2-708	-1-755	-1-754	-0-017	-0-017	-0-019	-0-018
10-0000-0-026	AF-CB-R-ME/LE HH	-2-701	-1-712	-1-751	-1-756	-1-019	-1-019	-0-002	-0-002
<b>**Machines for which the following (shorter than standard) arms and feet are available.</b>									
	SHORT FEET								
	5/8"	10-2046- 2-704	10-2050- 2-713	10-2046- 1-752	10-2050- 1-751	STANDARD		STANDARD	
	3/4"	2-704		10-2046- 1-753	10-2050- 1-752				
	Medium	2-704		10-2046- 1-754	10-2050- 1-753				
<b>***Machines for which the following (shorter than standard) arms and feet are available.</b>									
	SHORT FEET								
	3/4"	10-2046- 2-704	10-2050- 2-713	10-2046- 1-753	10-2050- 1-752	STANDARD		STANDARD	
	Medium	2-704	2-713	10-2046- 1-754	10-2050- 1-753				
	Regular	2-704	2-713	10-2046- 1-751	10-2050- 1-750				

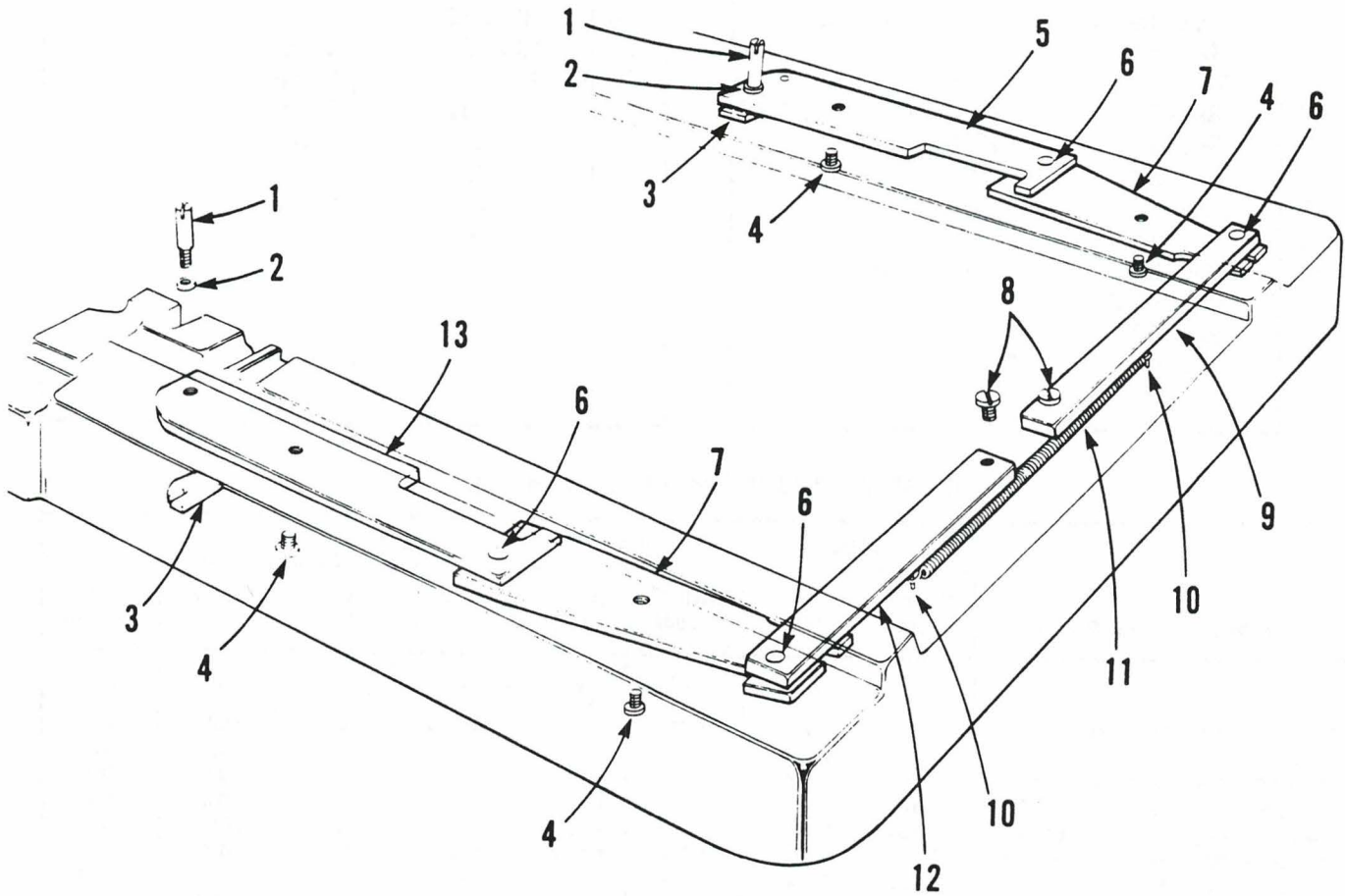

DET.	PART NUMBER	DESCRIPTION
1	10-2042	Screw
2	01-4067	Washer
3	10-2041	Locking Plate
4	01-1021	Screw
5	10-2040-0-050	Right Link Assembly
6	01-6075	Pin
7	10-2036	Front Link
8	01-1020-1	Screw
9	10-2033	Right Slide
10	01-6839	Pin
11	01-5023	Spring
12	10-2034	Left Slide
13	10-2039-0-050	Left Link

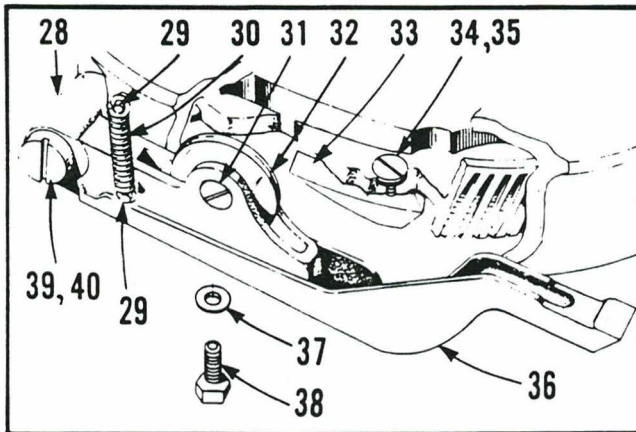
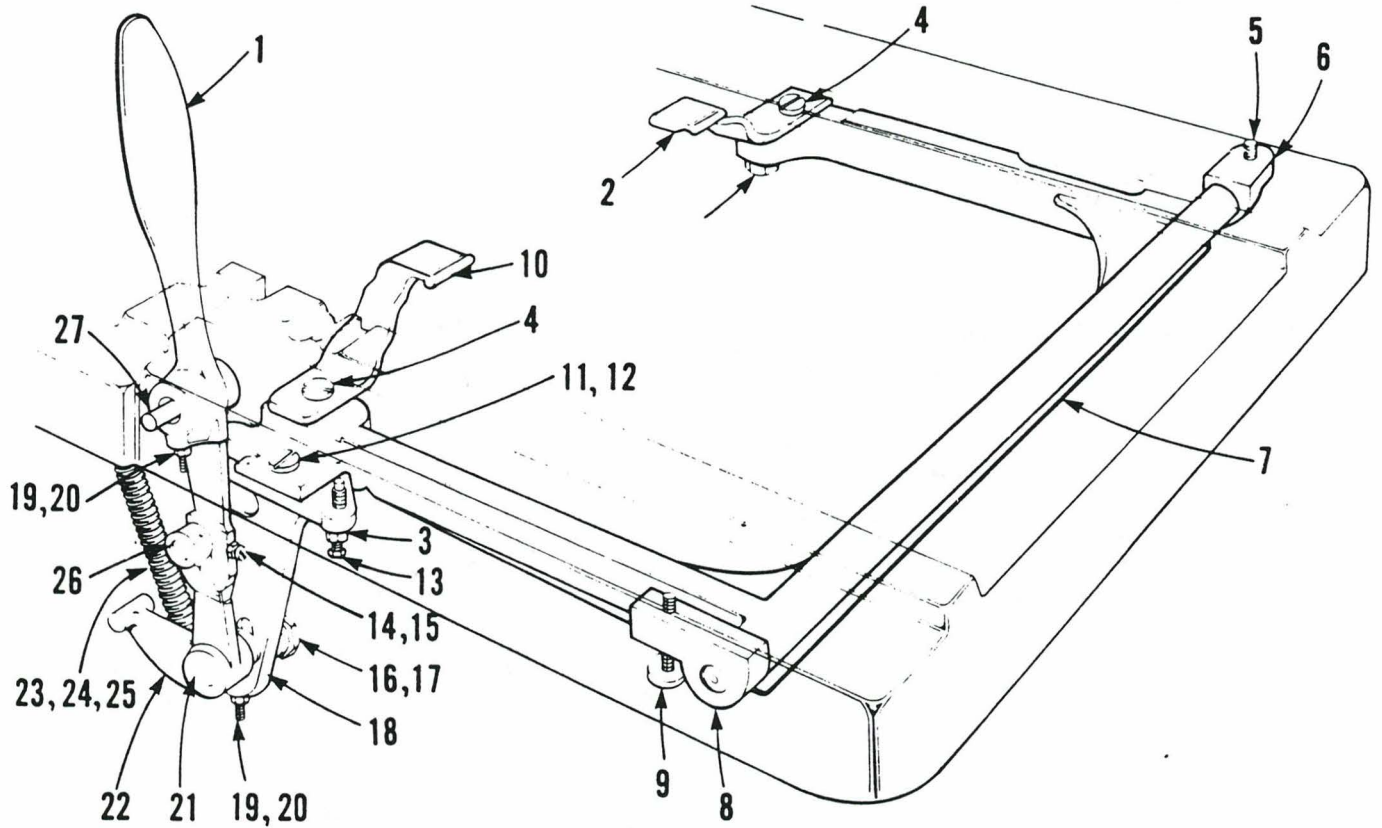

13	01-2069	Screw
14	01-2045	Screw
15	01-3016	Nut
16	01-3013	Nut
17	01-4005	Washer
18	10-2023	Toggle Bracket
19	01-2044	Screw
20	01-3001	Nut
21	10-2024	Stud
22	10-2021	Toggle Lever
23	01-6007	Hanger
24	01-5013	Spring
25	01-6006	Hanger
26	10-2022	Stud
27	10-2020	Stud
28	10-3023	Clamping Lever
29	01-6014	Pin
30	01-5015	Spring
31	10-3026	Screw
32	10-3025	Roller
33	10-3061-0-150	Wedge (C.A.)
	10-3061-0-200	Wedge (C.B.)
33	10-3061-0-300	Wedge AFCAB
34	01-2347	Screw
35	01-4061	Washer
36	10-3022	Arm
37	01-4006	Washer
38	01-2030	Screw
39	01-1076	Bolt
40	01-3014	Nut

DET.	PART NUMBER	DESCRIPTION
1	10-2019	Clamping Lever
2	10-2027-1	Right Pull Down
3	01-3007	Nut
4	01-2048	Screw
5	01-2328	Screw
6	10-2025-0-017	Block, R.H.
7	10-2026	Yoke
8	10-2025	Block, L.H.
9	01-2046	Screw
10	10-2028-1	Left Pull Down
11	01-2047	Screw
12	01-3017	Nut

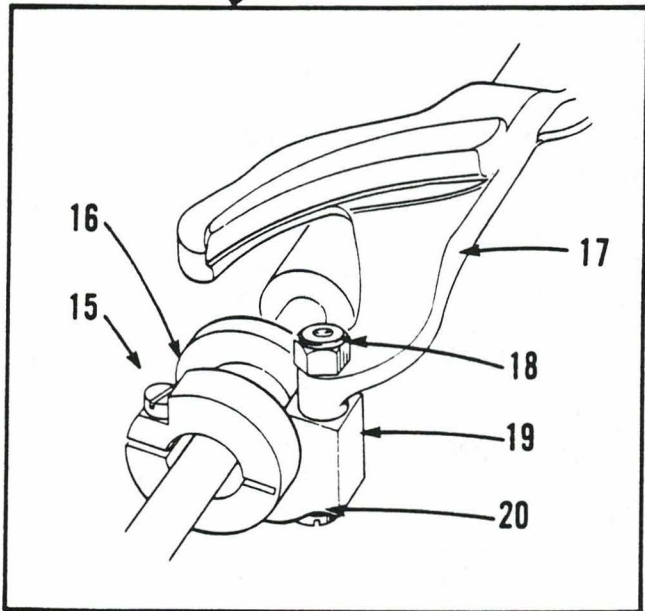
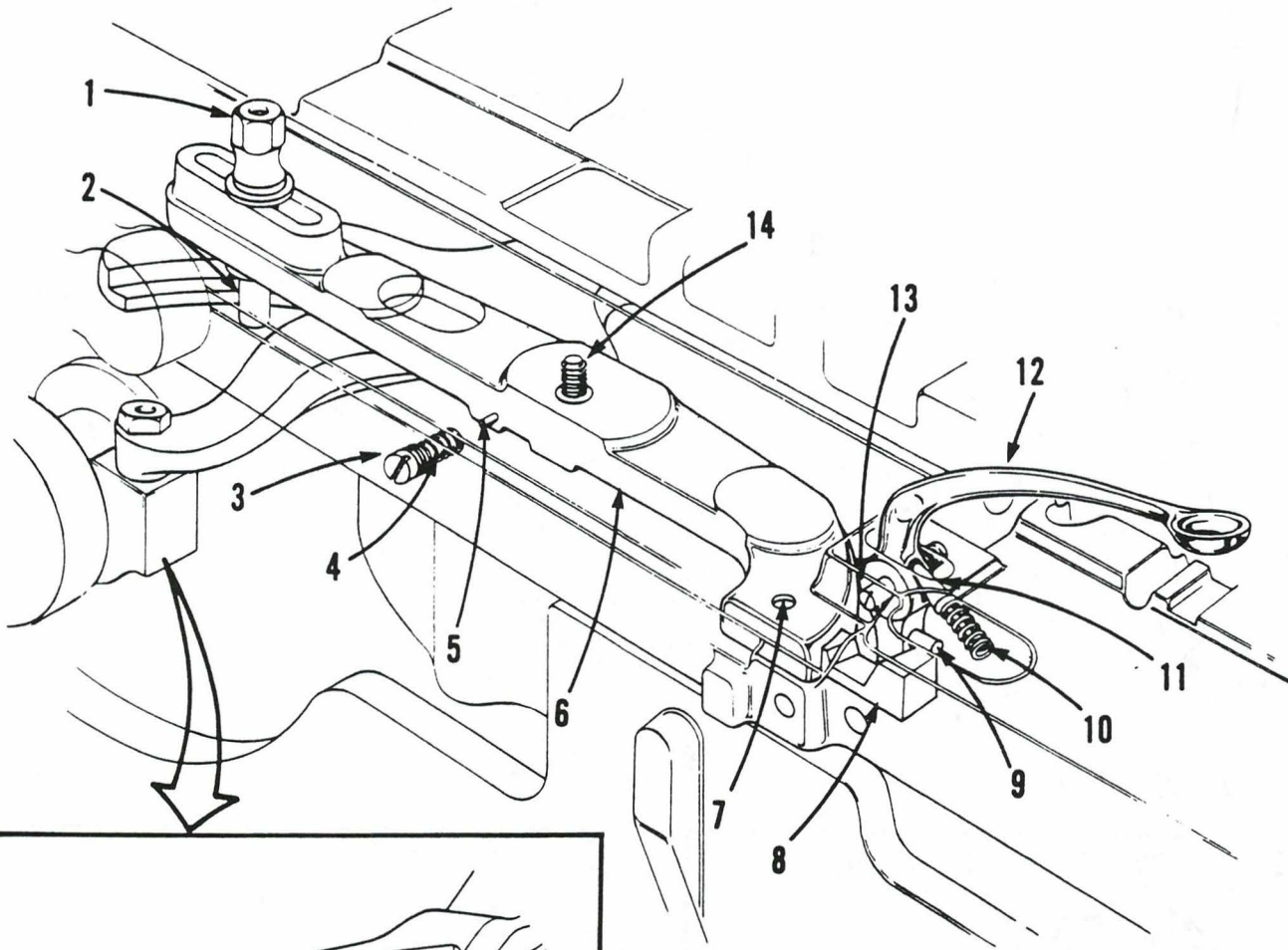

DET.	PART NUMBER	DESCRIPTION
1	10-2008	Nut
2	10-2009	Stud Screw
3	01-2071	Screw
4	01-5019	Spring Pin
5	01-6006	Spring

6	10-2012	Switching Lever Screw
7	01-2041	Screw
8	10-2010	Trip
9	01-6011	Pin
10	01-5020	Spring
11	10-2015	Plunger
12	10-2013	Starting Lever
13	10-2014	Pivot Screw
14	10-2011	Pivot Screw
15	01-2035	Screw
16	10-3045	Spool
17	10-3029-1	Shifting Lever(R)
	10-3029-0-008	Shifting Lever(L & XL)
18	01-3007	Nut
19	10-3031	Shifter Shoe Screw
20	01-2032-1	Screw

DET.	PART NUMBER	DESCRIPTION
1	10-1124	Trip Lever
2	01-3012	Nut
3	10-1126	Screw
4	01-3005	Nut
5	10-2018-1-250	Length Guide CA & CB R
	10-2018-1-017	Length Guide CA & CB L & XL
	10-2018-0-001	Length Guide 7 mm
6	10-2253	Tack Lever
7	10-2252	Screw
8	01-2075	Screw
9	See Chart	Length Gauge
10	14-2254	Adj. Bolt
11	01-4006	Washer
12	10-2250-1	Nut
13	01-2084	Screw
14	01-2024	Screw
15	01-4003	Washer
16	10-1127-3	Bracket
17	10-1203	Spring Anchor
18	01-6020-1	Pin
19	01-5088	Spring
20	10-1053	Cotter Pin
21	10-1125-2	Pivot Screw
22	01-2066	Screw
23	01-3011	Nut

LENGTH GAUGE CHART	
PART NUMBER	SIZE
10-2261-0-030	1/2" to 1 1/4" R
10-2261-0-031	5/8" to 1 3/4" R L
10-2261-0-032	5/8" to 2" X L
10-2261-0-040	30 mm R
10-2261-0-041	45 mm R L
10-2261-0-042	50 mm X L

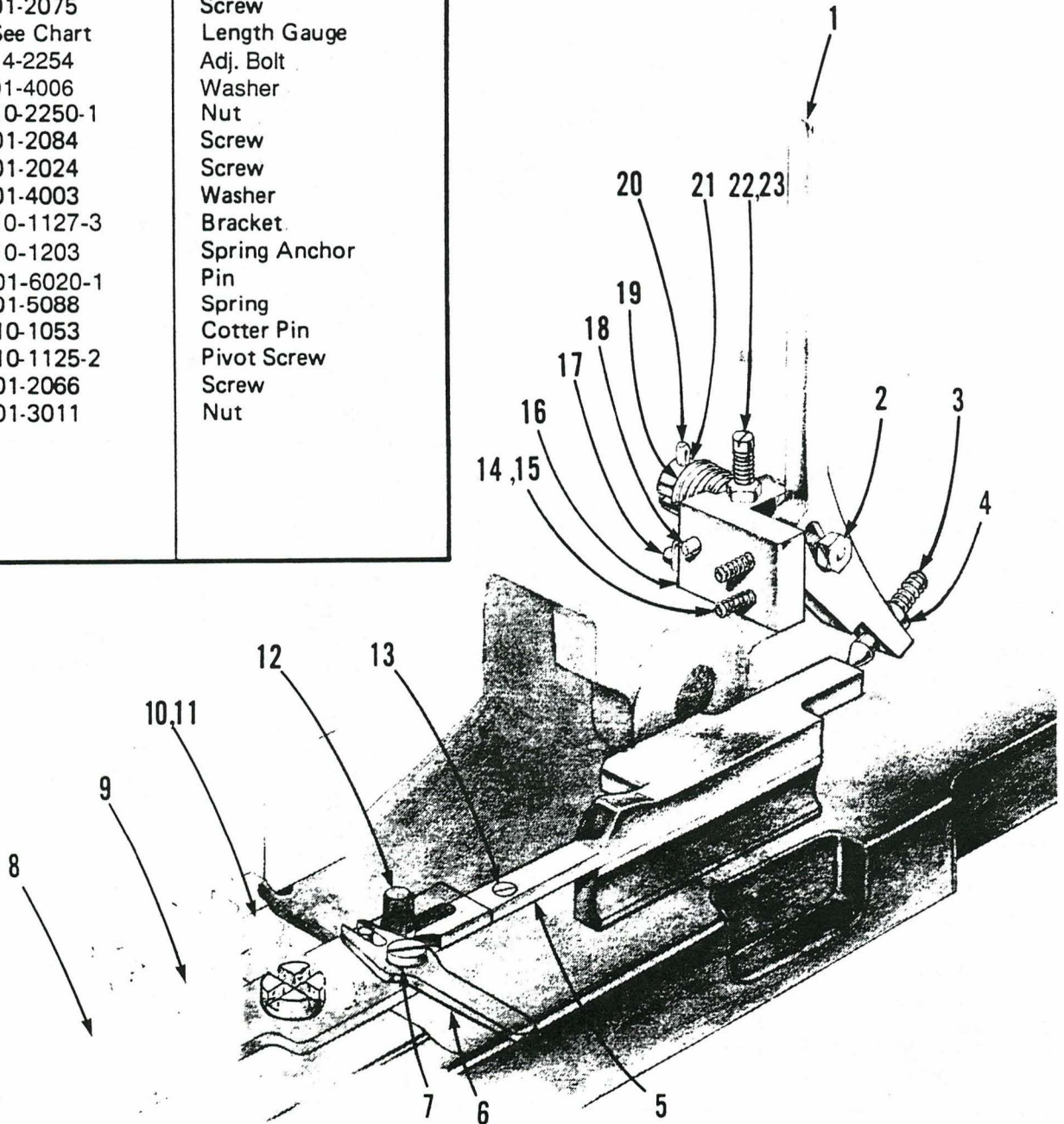

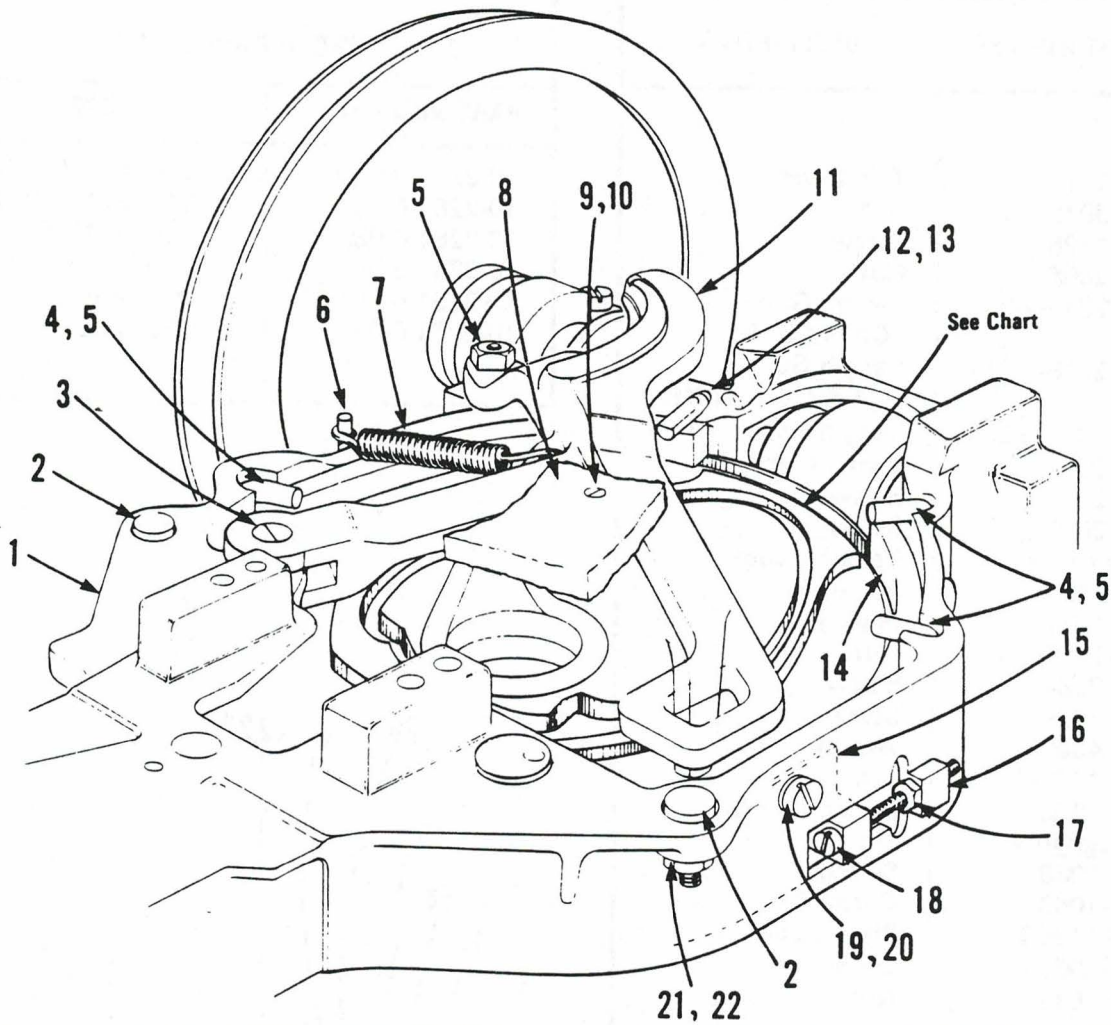

MAIN CAM CHART		
PART NUMBER	DESCRIPTION	STYLE NO.
14-3064-0-001	AF-CA-R-RE	10-0000-0-016
14-3064-0-006	AF-CA-R-R-RE-MB	10-0000-0-017
10-3064-0-016	AF-CA-XL-LE	10-0000-0-019
10-3064-0-011	AF-CB-R-FE	10-0000-0-022
10-3064-0-010	AF-CB-R-RE	10-0000-0-023
10-3064-0-014	AF-CB-RL-ME	10-0000-0-024
10-3064-0-015	AF-CB-RL-LE	10-0000-0-025
10-3064-1-008	AF-CB-R-ME/LE-HH	10-0000-0-026

DET.	PART NUMBER	DESCRIPTION
1	10-3001-2	Cam Case
2	10-3028	Button
3	10-3032-1	Screw
4	10-3066-0-011	Long Hook
5	01-3007	Nut

6	01-6025	Pin
7	01-5055	Spring
8	10-3030	Felt Pad
9	01-2004	Screw
10	01-4001	Washer
11	10-3029-1	Shifting Lever (R)
	10-3029-0-008	Shifting Lever (L & XL)
12	10-3066-0-008	Short Hook
13	01-3059	Nut
14	10-3035-1	Hold Down Gib
15	10-3036	Brake Band
16	01-6345	Lug
17	01-3005	Nut
18	01-2033	Screw
19	01-4018	Washer
20	01-2027	Screw
21	01-2067	Screw
22	01-3015	Nut

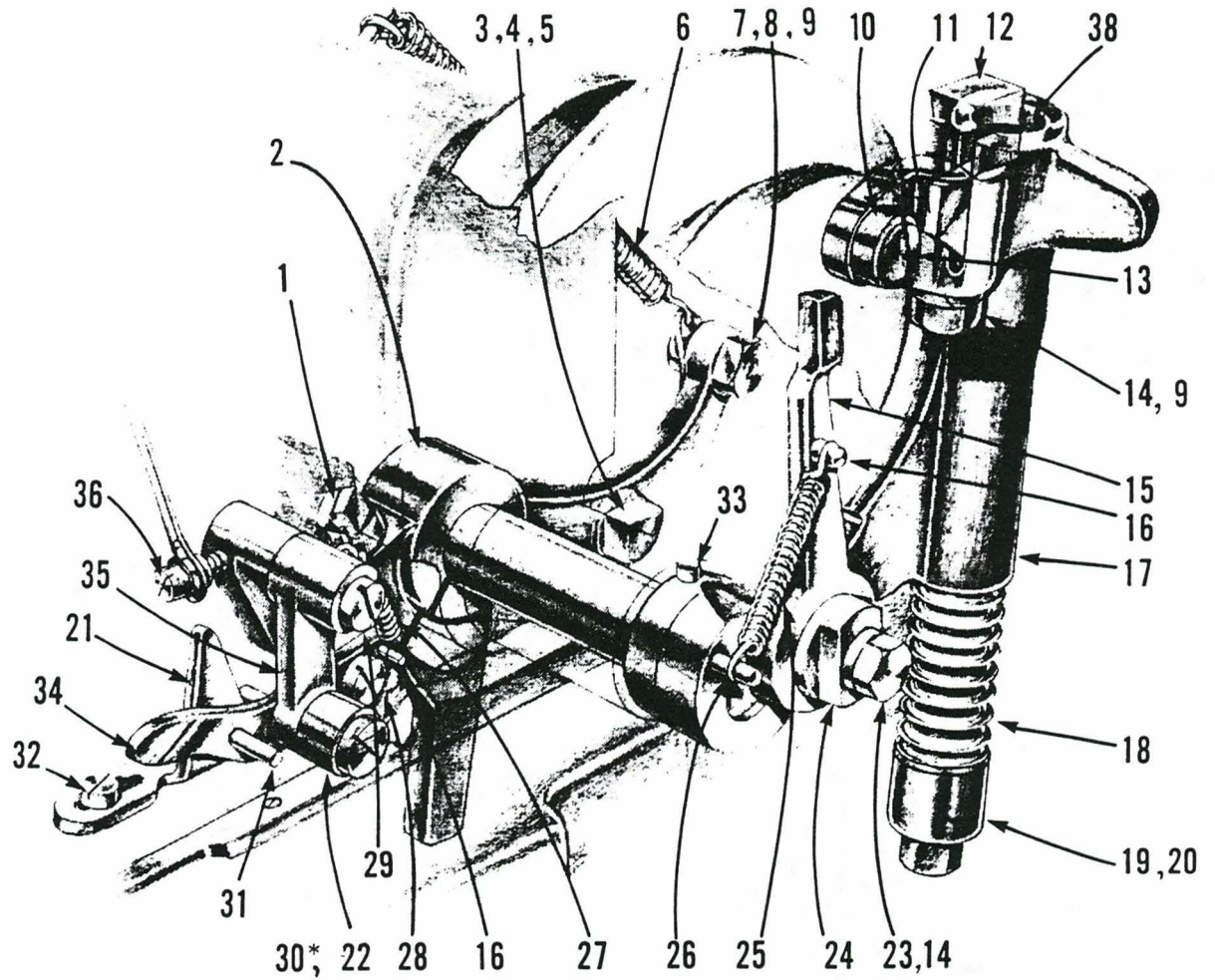

DET.	PART NUMBER	DESCRIPTION
1	10-1114	Screw
2	10-1113	Three Fork Lever
3	10-1117	Dog
4	01-3005	Nut
5	01-4011	Washer
6	01-5013	Spring
7	10-1116	Clip
8	01-2061	Screw
9	01-3007	Nut
10	01-7002	Roll
11	10-1009	Bushing
12	10-1102-1	Dog
13	01-6350	Stud
14	01-4004	Washer
15	10-1100	Latch
16	01-6005	Pin
17	10-1098-1-050	Rocker Arm & Shaft
18	01-5010	Spring
19	01-4034-0-003	Washer
20	01-3436	Nut

21	10-2016	Bumper
22	10-1121-0-017	Screw
23	01-2020	Screw
24	10-1101	Eccentric
25	01-5011	Spring
26	01-6014	Pin
27	01-5014	Spring
28	10-1119	Screw
29	01-1095	Screw
30	10-1122-0-010*	Roll
31	01-6021	Pin
32	01-2042	Screw
33	01-6040	Pin
34	10-1118	Lever
35	10-1120	Link
36	01-2329	Screw
38	10-1099	Bolt

\*Used on AF-CA-XL-LE; AF-CB-RL-ME; AF-CB-RL-LE

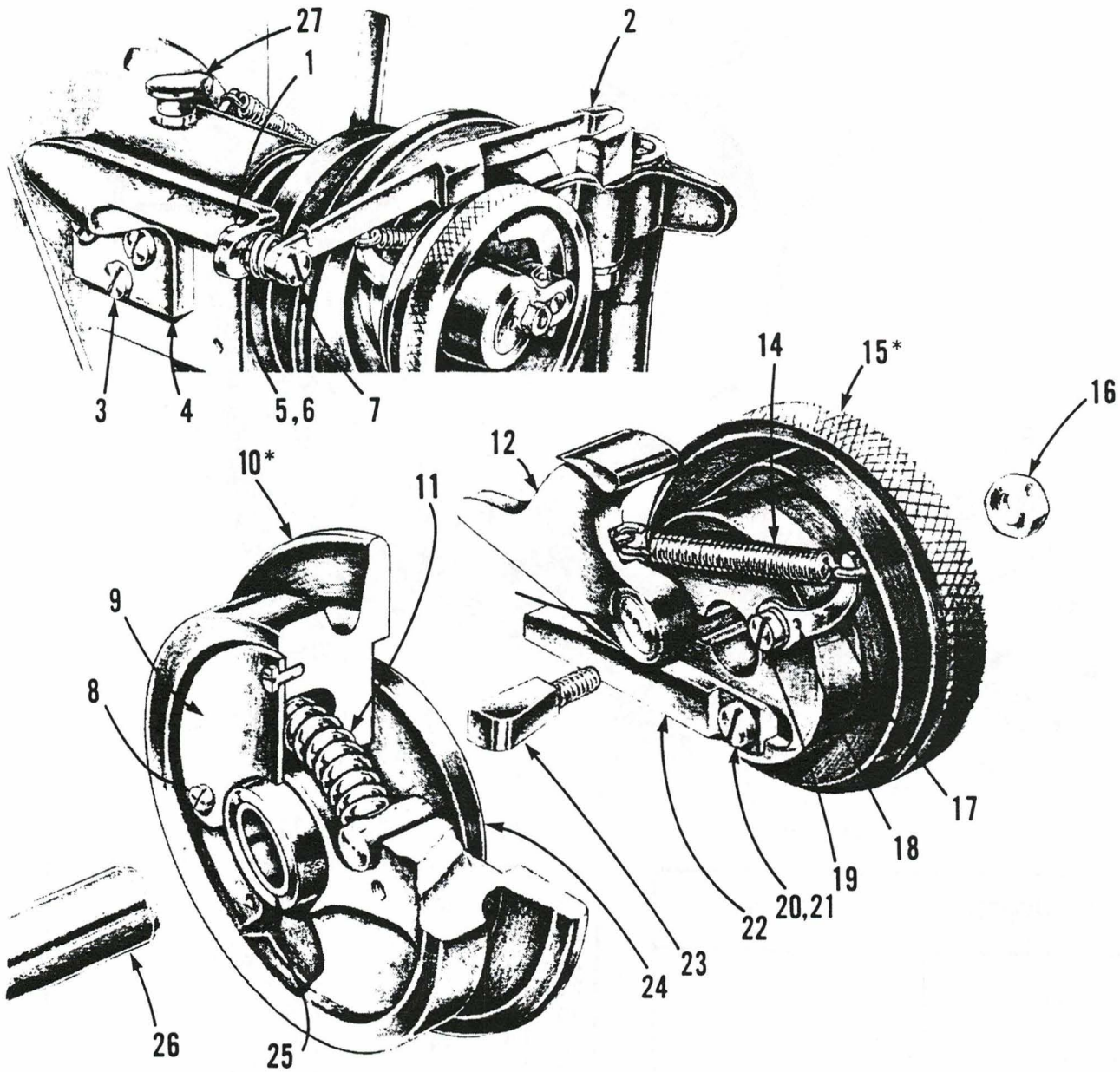

DET.	PART NUMBER	DESCRIPTION
1	01-3005	Nut
2	10-1085	Flyover Lever
3	01-2017	Screw
4	10-1087	Bracket
5	01-4002	Washer
6	01-5007	Spring
7	10-1086	Screw
8	01-2019	Screw
9	13-1096	Cover Plate
10	10-1094-3-850	Stitch Pulley
11	01-5009	Spring
12	10-1089	Clutch Dog

14	01-5450	Spring
15	10-1088-0-050	Stop Wheel
16	01-3007	Nut
17	10-1090	Arm
18	01-6600	Pin
19	01-2079	Screw
20	01-2571	Screw
21	01-4019	Washer
22	10-1155-1	Stop
23	10-1097-1	Key
24	10-1095-3	Drive Cam
25	01-7468	Bushing
26	10-1091-0-000	Stitch Cam & Shaft Assembly
27	10-1149	Oil Cup

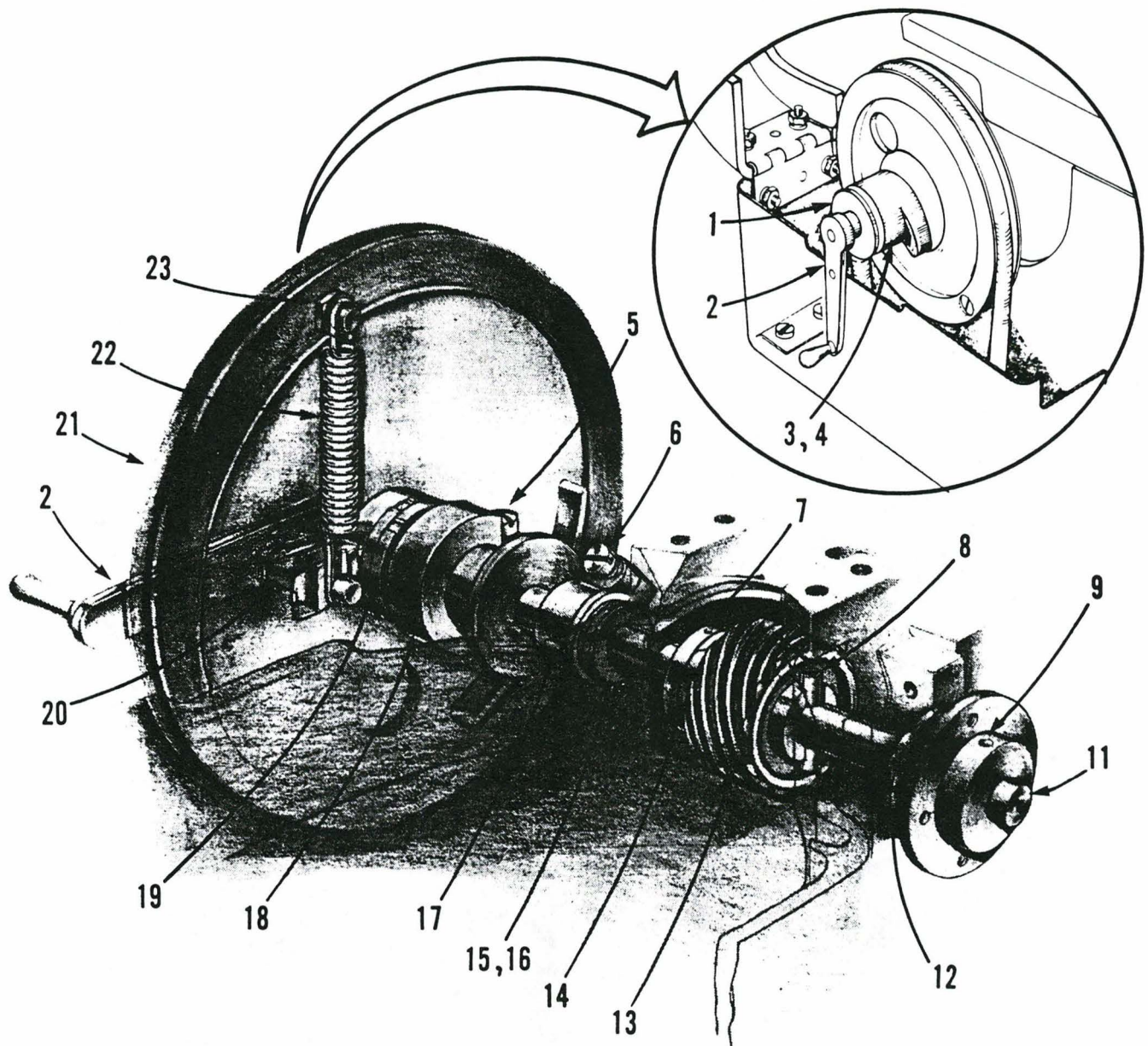

DET.	PART NUMBER	DESCRIPTION
1	10-1194-0-016	Floating Shaft
2	10-1194-0-014	Crank & Handle
3	10-1194-0-013	Screw
4	10-1194-0-007	Hub
5	01-2035	Screw
6	01-2024	Screw
7	10-3049	Collar
8	10-3051	Pin
9	01-6028	Pin

11	10-3047-1-050	Drive Shaft Asm.
12	01-4023	Washer
13	10-3050	Worm Gear
14	01-4009	Lock Washer
15	01-4007	Flat Washer
16	01-4008	Spring Washer
17	10-3046	Friction Collar
18	10-3045	Spool
19	10-3041	Lock Nut
20	10-3042	Striker
21	10-3039	Left Pulley
22	01-5017	Spring
23	10-3040-1	Anchor

10-1108-1-100 Assembly

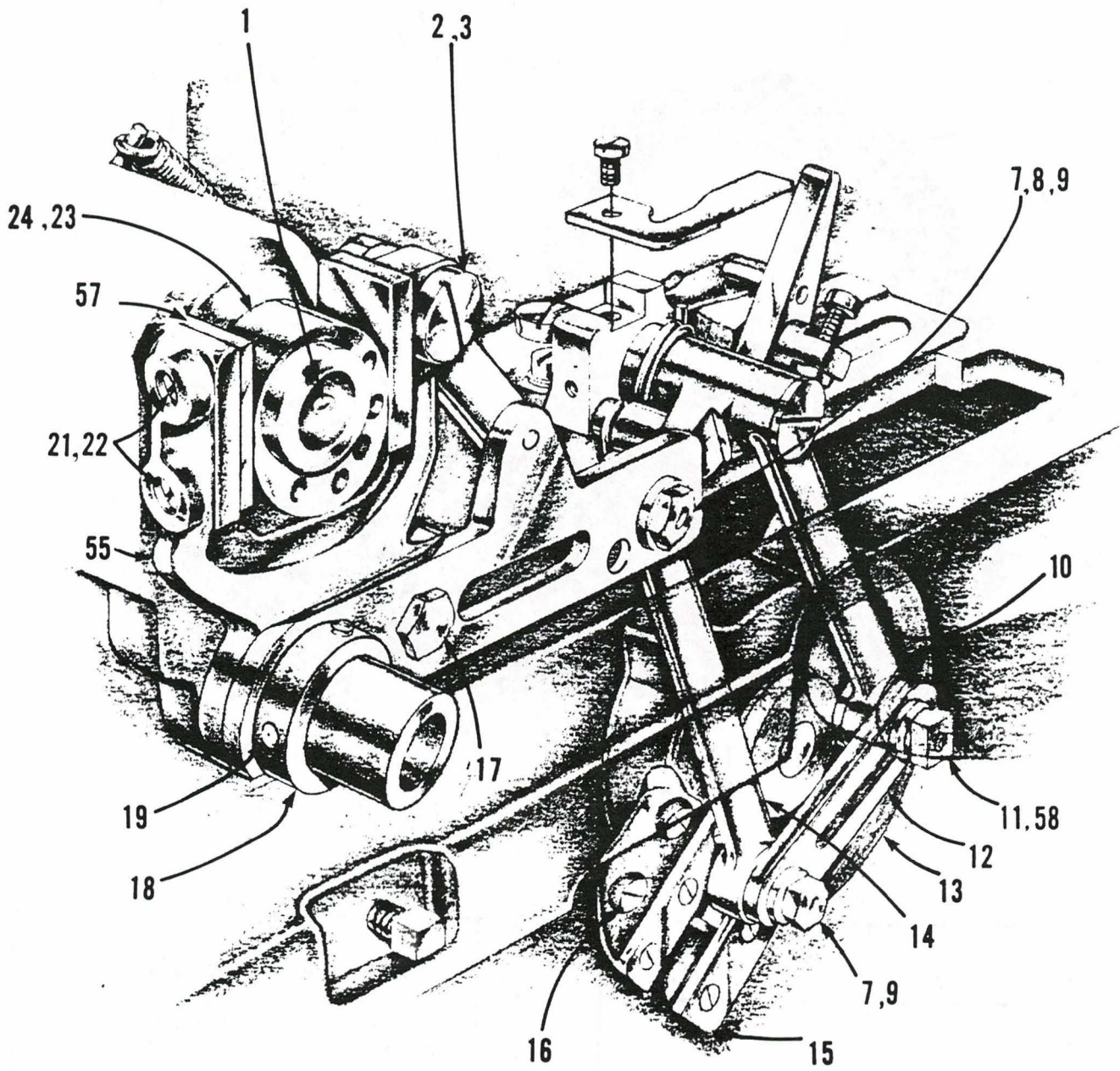

DET.	PART NUMBER	DESCRIPTION
1	01-2249	Screw
2	10-2011	Screw
3	01-3009	Nut

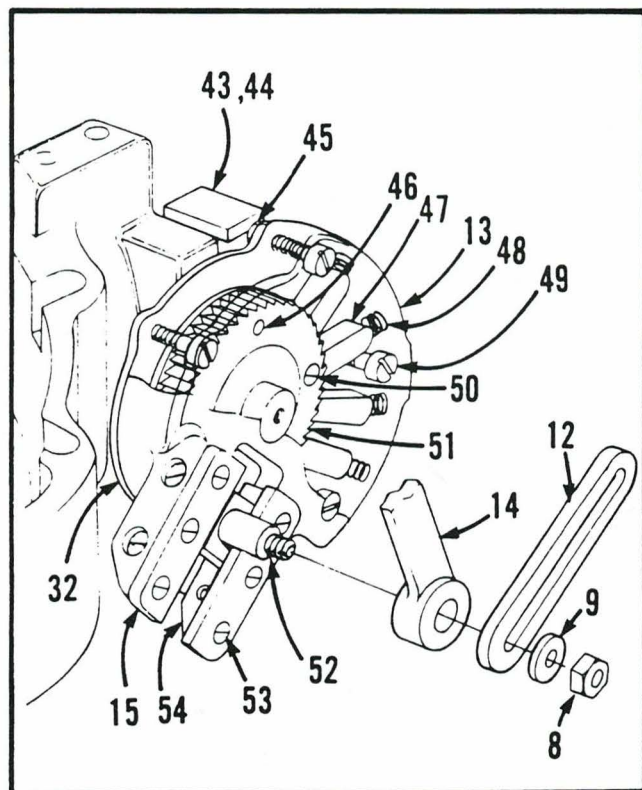
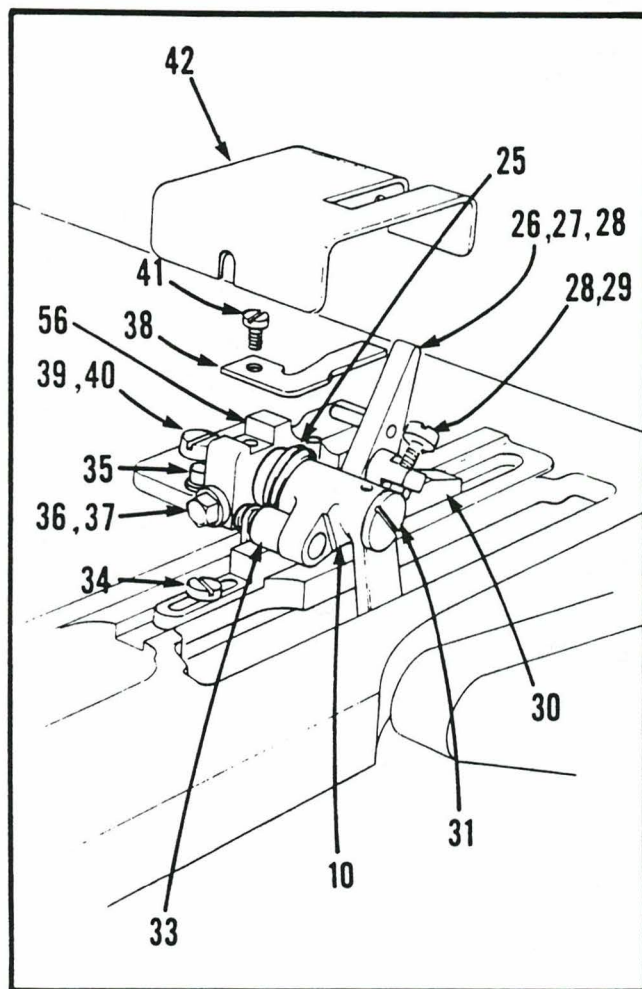

7	01-1132	Screw
8	01-3042	Nut
9	01-4063	Washer
10	10-1168	Link
11	01-3019	Nut
12	10-3081	Arm
13	10-3053-1	Pawl Case
14	10-1109-3	Link
15	10-3080	Outer Plate
16	01-2008	Screw
17	01-2030	Screw
18	01-7038	Collar
19	01-2028	Screw
21	01-4019	Washer
22	01-2022	Screw
23	10-1093-1	Feed Cam
24	01-8002	Key
25	01-5448	Spring
26	10-1169	Switch Lever
27	01-4042	Washer
28	01-3005	Nut
29	01-2391	Screw
30	10-2061	Stitch Take-Out Wedge
	10-2061-0-994	Stitch Increase Wedge
31	01-2146	Screw
32	10-3054-2	Inner Case Cover
33	10-2007-0-350	Roll
34	01-2041	Screw
35	01-2130	Screw
36	01-4052	Washer
37	01-2390	Screw
38	01-5447	Leaf Spring
39	01-6428	Pin
40	01-2568	Screw
41	01-2344	Screw
42	10-1170	Stitch Feed Cover
43	10-3083	Support
44	01-2061	Screw
45	01-3001	Nut
46	01-6023	Pin
47	10-3052	Pawl
48	01-5018	Spring
49	01-2037	Screw
50	01-2002	Screw
51	10-3048	Ratchet
52	10-3079	Stud
53	01-2075	Screw
54	10-3082	Inner Plate
55	10-1108-1-100	Stitch Feed Asm.
56	10-1167-1	Shifter Block
57	10-1107	Plate
58	01-1028	Stud

DET.	PART NUMBER	DESCRIPTION
1	01-7004	Roll
2	10-3020	Stud
3	01-4005	Washer
4	01-3013	Nut
5	10-3019	Lower Lateral Lever
6	01-2016	Screw
7	01-2392	Screw
8	10-2258	Cover
9	10-2257	Shifter
10	10-2001-3-250	Bedplate
11	10-2260-0-200	Guide Plate
	10-2260-0-217	(CB-RL only)
	10-2260-0-167	(CA-XL only)
	10-2260-0-001	7 mm only
12	01-7023	Roll
13	10-3034-0-258**	Upper Lateral Lever
	10-3034-0-261	(CB-RL only)
14	01-7043	Roll
15	10-2259	Plunger
16	01-5172	Spring

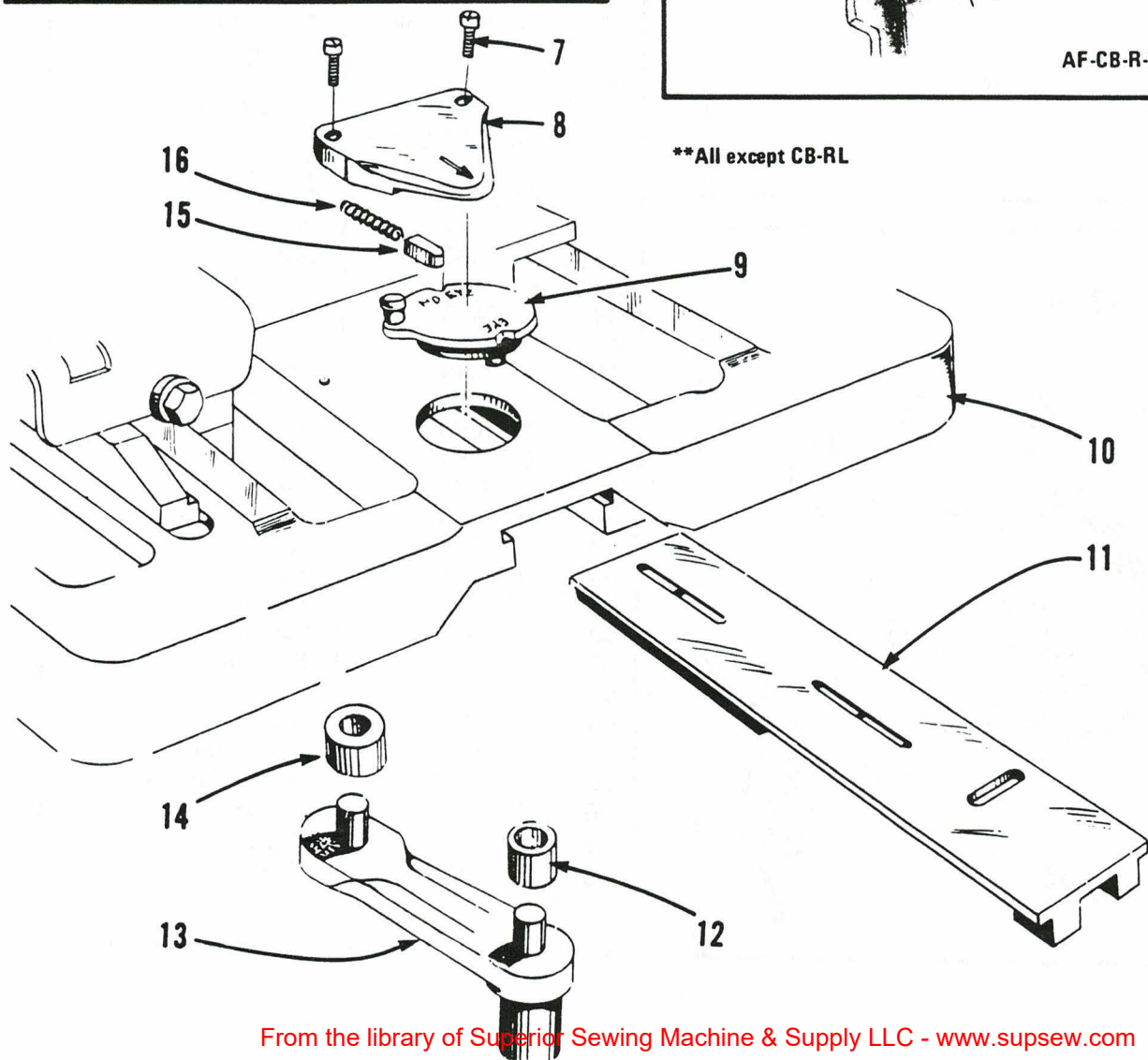
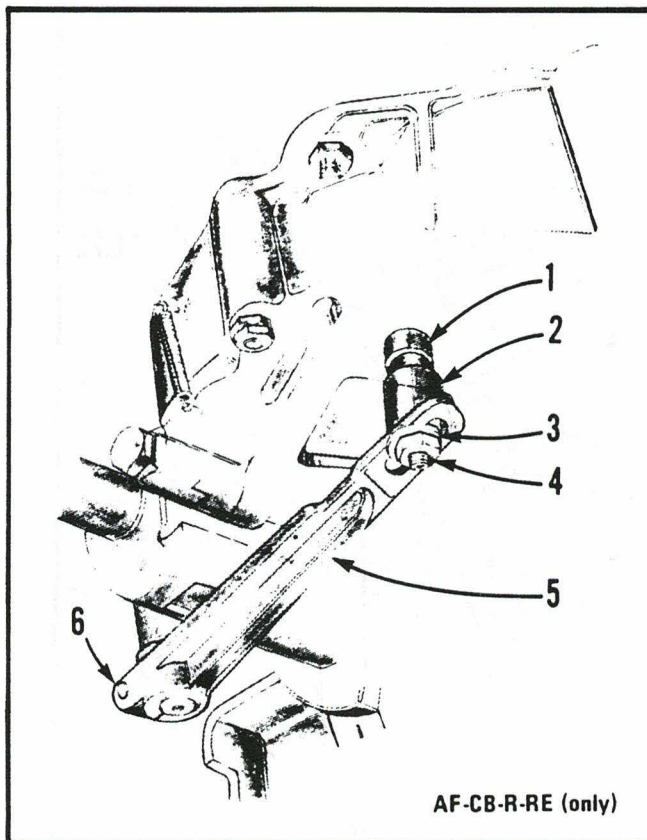

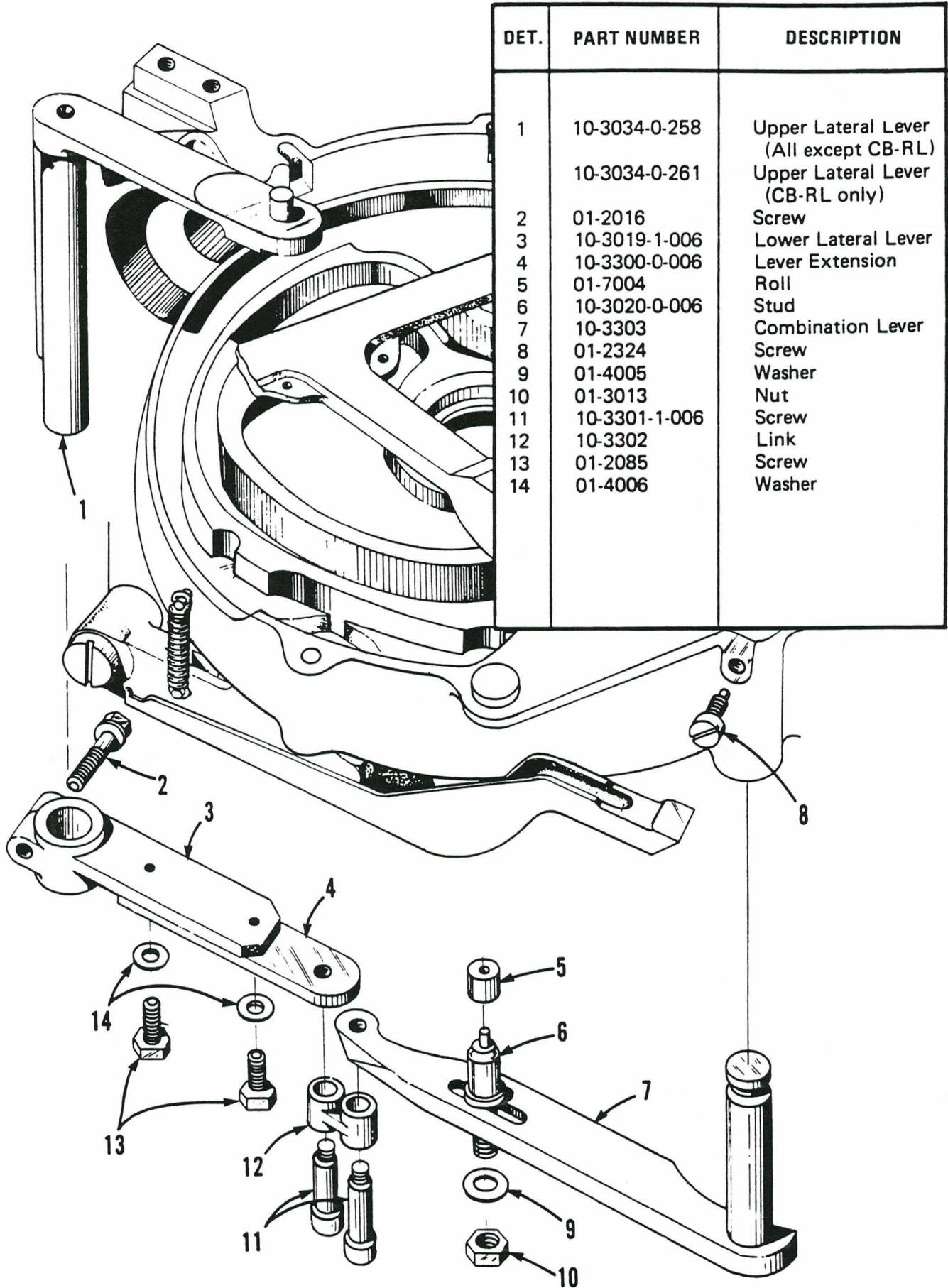

DET.	PART NUMBER	DESCRIPTION
1	10-3034-0-258	Upper Lateral Lever (All except CB-RL)
	10-3034-0-261	Upper Lateral Lever (CB-RL only)
2	01-2016	Screw
3	10-3019-1-006	Lower Lateral Lever
4	10-3300-0-006	Lever Extension
5	01-7004	Roll
6	10-3020-0-006	Stud
7	10-3303	Combination Lever
8	01-2324	Screw
9	01-4005	Washer
10	01-3013	Nut
11	10-3301-1-006	Screw
12	10-3302	Link
13	01-2085	Screw
14	01-4006	Washer

DET.	PART NUMBER	DESCRIPTION
1	10-3250-1	Spacer Wedge
2	14-3251-0	Bracket
3	01-5054	Spring
4	01-6006	Pin
5	10-2255-1-264	Cam Plate AF-CA-R-RE-MB
	10-2255-2-150	Cam Plate AF-CA-R-RE, AF- CB/CA-R-RE
	10-2255-3-200	Cam Plate AF-CB-R-FE, AF-CB- R-RE, AF-CB-R- ME/LE-HH
	10-2255-2-167	Cam Plate AF-CA-XL-LE
	10-2255-3-217	AF-CB-RL-ME, AF- CB-RL-LE
6	10-3252-1	Pin
7	01-1447	Stud
8	10-2256	Bracket
9	01-2043	Screw
10	10-3254	Pin Actuator
11	01-1432	Screw
12	10-3259-1-001	Wire Rod Right
	10-3259-1-002	Wire Rod Left
13	10-3018	Roll
14	14-3017	Stud
15	10-3015-0-250	Sector Lever
16	10-3016	Stud
17	01-2079	Screw
18	01-3016	Nut
19	10-3258	Bracket
20	01-1395-0-004	Screw
21	01-4503	Washer
22	01-2031	Screw
23	10-3027	Plate
24	10-3012	Link
25	01-4472	Washer
26	10-3253	Pin Actuator
27	10-3257	Spacer Washer
28	01-2088	Screw
29	01-4046	Lockwasher
30	01-6031	Taper Pin
31	10-3262-0-250	Lever
32	01-2006	Screw

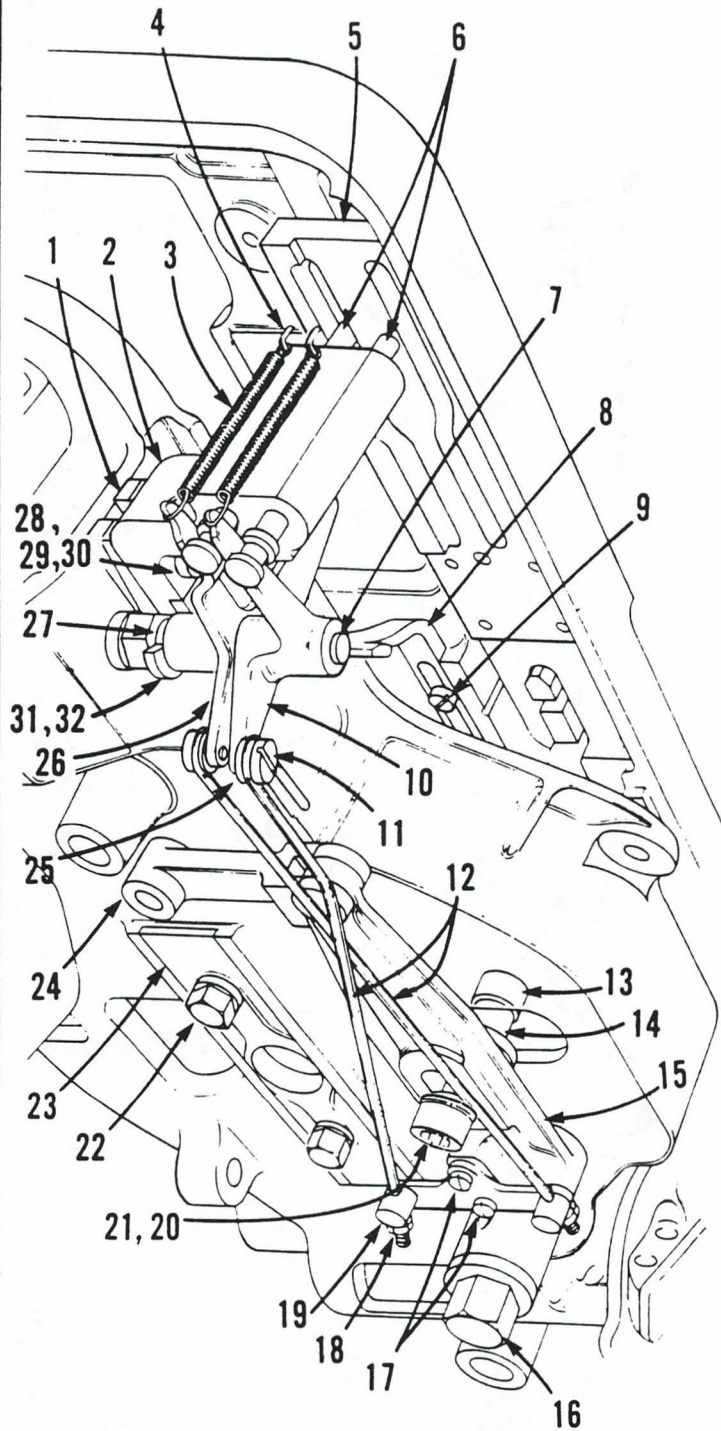

Needles for the Reece Series 101 machines are packaged and sold in boxes of 100, in the sizes and types listed. They are of superior struck groove construction, chrome plated and are spotted at the eye except in size 00 and finer. When ordering, specify quantity - - (100, 200 etc.) and give the Needle E.D.P. Number.

TYPE	APPLICATION	E.D.P. NUMBER	CODE NUMBER	NEEDLE BLADE SIZE
ROUND POINT LONG SHANK	Applicable to the majority of woven fabrics, knits and other materials of similar consistency. The Long Shank needles have added stiffness in the blade which permits the use of one size smaller needle than would be normally required. Long Shank needles can not be used on heavy material that would be penetrated by the tapered portion of the needle shank.	02-0500-1-000 02-0500-1-100 02-0501-1-110	500-LS-000 500-LS-00 501-LS-0	Extra Fine Very Fine Fine
ROUND POINT		02-0501-0-111 02-0501-0-112 02-0501-0-113	501-1 501-2 501-3	Medium Heavy Very Heavy
ROUND POINT BALL EYE	Applicable to closely woven fabrics or where sewing is over heavy seams, particularly in cottons. In sewing, the Ball Eye produces a hole in the fabric slightly in excess of the needle blade diameter, thereby reducing needle heating below that of a needle with uniform blade diameter.	02-0501-3-111 02-0502-0-112 02-0502-0-113	502-2 502-3	Medium Heavy Very Heavy
ROUND POINT DOUBLE GROOVE	The Double Groove needle should be used only when conditions justify it because it casts a smaller loop than standard needles and may introduce skipping. For this reason looper points should be set close to needle blade. This needle is used on materials having a tendency to trap the thread in its descent into the work which affects the thread takeup, or causes the thread to break at the needle's eye.	02-0503-0-111 02-0503-0-112 02-0503-0-113	503-1-DG 503-2-DG 503-3-DG	Medium Heavy Very Heavy
EXTRA LONG POINT BALL EYE	Applicable to fabrics which offer high resistance to needle penetration. Also recommended in cases where fast timing of the loopers is necessary. This needle differs from the 501 type needle only in length from the eye to the point.	02-0504-0-111 02-0504-0-112 02-0504-0-113 02-0504-0-114	504-1 504-2 504-3 504-4	Medium Heavy Very Heavy Extra Heavy
BALL POINT LONG SHANK	Applicable to synthetic fabrics, particularly of the tightly woven or tightly knitted types where the fibers of the material are subject to damage by conventional sharp pointed needles. The Long Shank needles of this type have the advantages stated above for Round Point Long Shank needles.	02-0505-1-100 02-0505-1-110	505-LS-00 505-LS-0	Very Fine Fine
BALL POINT		02-0505-0-111	505-1	Medium
ROCKED POINT BALL EYE	Applicable to leather and similar materials where conventional sharp pointed needles tend to leave excessive punctures. The split made by Rocked Point needles in leather will tend to close up after penetration. This needle permits a higher stitch density than is possible in leather with a Round Point needle.	02-0506-0-111 02-0506-0-112 02-0506-0-113 02-0506-0-114	506-1 506-2 506-3 506-4	Medium Heavy Very Heavy Extra Heavy
SPEAR POINT	Applicable to fabrics containing a high percentage of starch or similar substances which tend to cause needle heating or resistance to proper pulling up of the stitches.	02-0508-0-111 02-0508-0-112 02-0508-0-113	508-1 508-2 508-3	Medium Heavy Very Heavy

Size of Roll is etched on both sides of Stitch Cam.

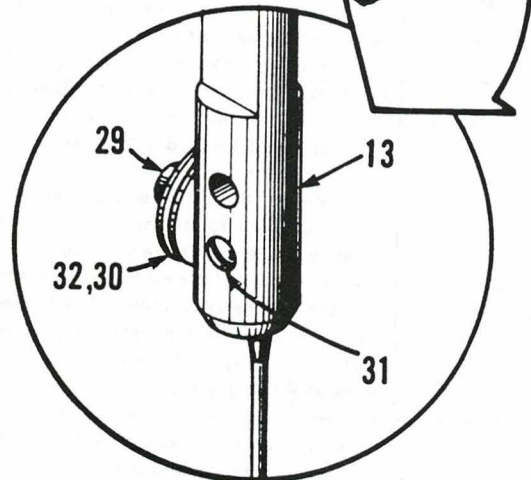
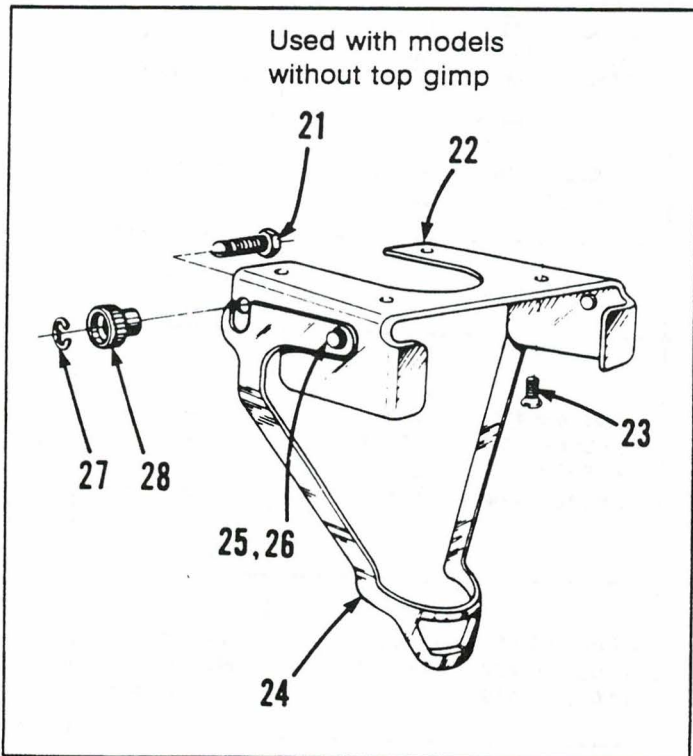
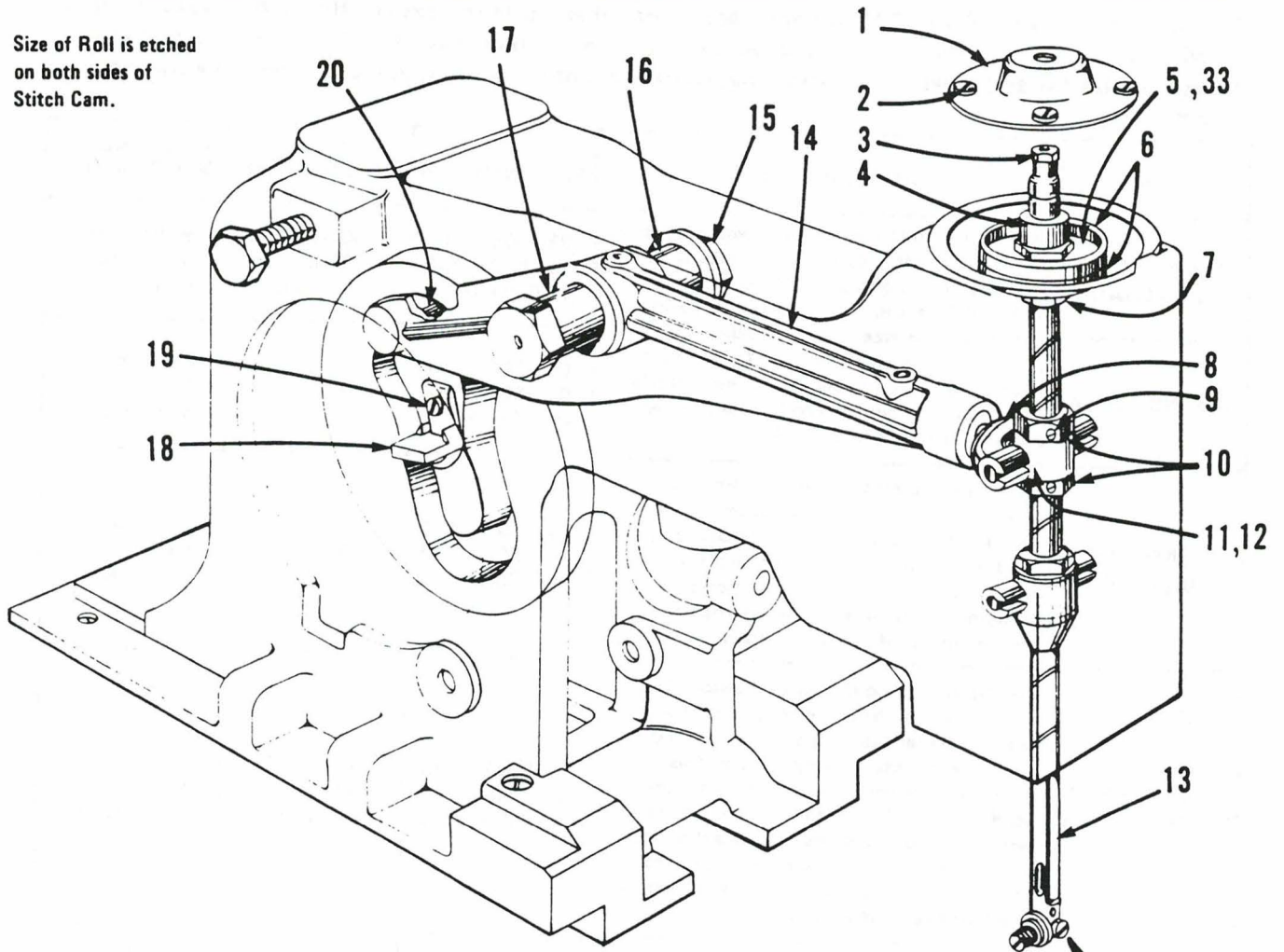

34 KIT NEEDLE GUARD

DET.	PART NUMBER	DESCRIPTION
1	10-1014-1	Cap
2	01-2131	Screw
3	10-1032	Bushing
4	14-1017	Guide
5	14-1016-0-050	Needle Bar Guide
6	10-1015-1	Spacer
7	10-1016-2	Nut
8	10-1046-2	Yoke
9	01-2419	Screw
10	10-1027-1-050	Screw
11	10-1045-2	Gimbal
12	01-7015	Bushing
13	10-1028-2	Needle Bar
14	14-1047	Lever
15	01-3004	Nut

*14-1028-000*

16	10-1049	Bushing
17	10-1050	Pivot Stud
18	10-1152	Clip
19	01-2079	Screw
20	See Chart	Roll
21	01-2248	Screw
22	10-1193-2-002	Bracket
23	01-2075	Screw
24	10-1193-2-001	Guard
25	01-6404	Retainer
26	01-6834	Pin
27	01-6368	Retainer
28	01-3512	Nut
29	10-1030-0-017	Screw
30	10-1029-1	Disc
31	01-2193	Screw
32	01-5167	Spring
33	10-1042-2	Diaphragm
34	10-1193-1	Kit Needle Guard

ROLL CHART		
DIA.	ROLLER PART NO.	SIZE
.5000 + .0000 - .0003	10-1122-0-010	STD.
.5002 + .0000 - .0002	10-1122-0-999	#1 O.S.
.5004 - .0000 - .0002	10-1122-0-998	#2 O.S.
.5006 + .0000 - .0002	10-1122-0-980	#3 O.S.
.5008 + .0000 - .0002	10-1122-0-979	#4 O.S.
.5010 + .0000 - .0002	10-1122-0-011	#5 O.S.
5014 + .0000 - .0002	10-1122-0-012	#6 O.S.
5018 + .0000 - .0002	10-1122-0-013	#7 O.S.
5022 + .0000 - .0002	10-1122-0-014	#8 O.S.
5026 + .0000 - .0002	10-1122-0-015	#9 O.S.
5030 + .0000 - .0002	10-1122-0-016	#10 O.S.

TO BE USED  
ON OVERSIZED  
CAM SLOTS

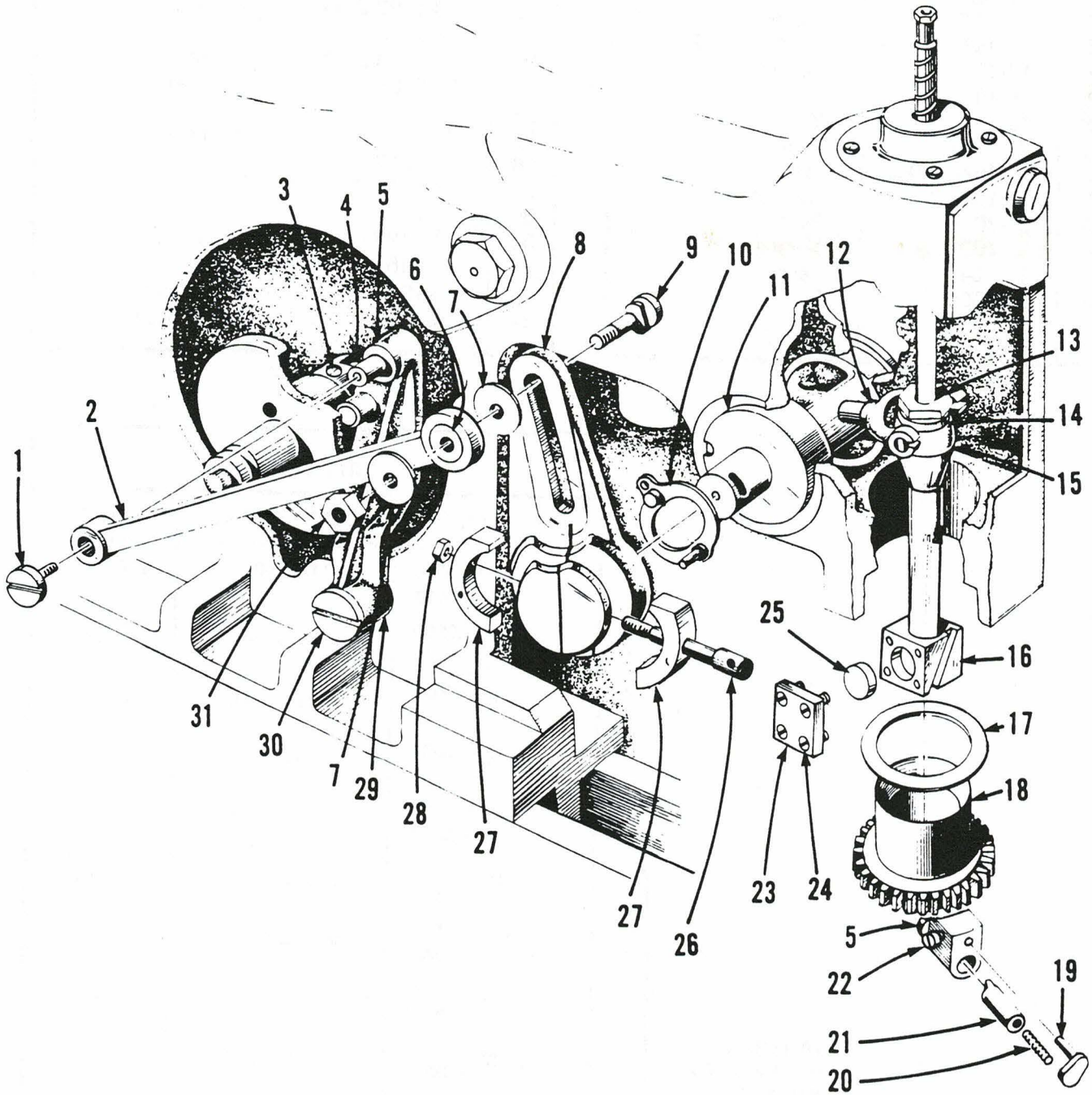

DET.	PART NUMBER	DESCRIPTION
1	01-2011	Screw
2	14-1041	Drag Link
3	10-1031	Screw
4	10-1076	Coupling Block
5	10-1024-0-002	Washer (Stan) .0779" - .0782"
	10-1024-0-001	Washer (O.S.) .0782" - .0785"
	10-1024-0-003	Washer (O.S.) .0776" - .0779"
6	10-1040	Bushing
7	10-1039	Washer
8	10-1038-2	Crank
9	10-1037	Stud
10	10-1153	Plate
11	14-1035-0	Barrel
12	10-1034	Yoke
13	10-1156	Nut
14	01-4034-0-001	Washer .0623" - .0626"
	01-4034-0-002	Washer .0626" - .0629"
	01-4034-0-003	Washer .0629" - .0632"
	01-4034-0-004	Washer .0632" - .0635"
	01-4034-0-005	Washer .0635" - .0638"

15	10-1033-1	Gimbal
16	10-1026-2	Block
17	01-4081-0-005	Shim (.005" thick)
	01-4081-0-006	Shim (.006" thick)
	01-4081-0-007	Shim (.007" thick)
	01-4081-0-008	Shim (.008" thick)
	01-4081-0-009	Shim (.009" thick)
	01-4081-0-010	Shim (.010" thick)
	01-4081-0-011	Shim (.011" thick)
	01-4081-0-012	Shim (.012" thick)
18	10-1023-3	Gear
19	10-1021-1	Retainer
20	01-5003	Spring
21	10-1022	Guide
22	01-2008	Screw
23	10-1065	Cap
24	01-2100	Screw
25	10-1025-1	Button
26	10-1036-1	Bolt
27	10-1147	Block
28	01-3028	Nut
29	14-1043	Cam Follower
30	10-1044	Screw
31	01-3012	Nut

When ordering button 10-1025-1 specify additional button number in description column of part order.

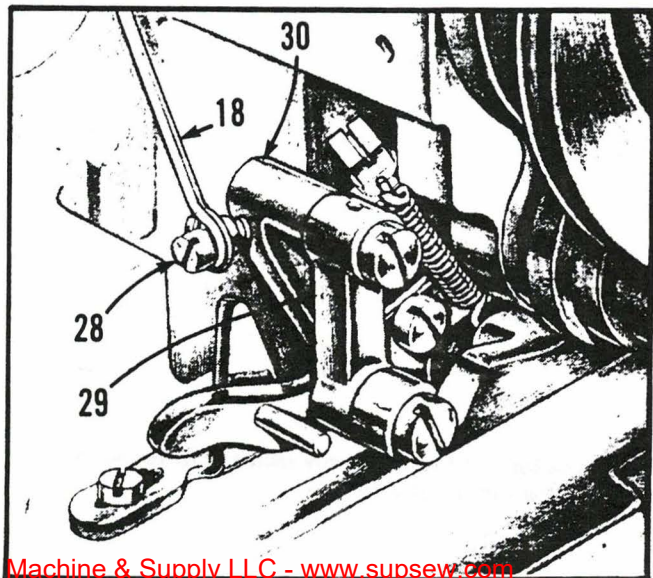
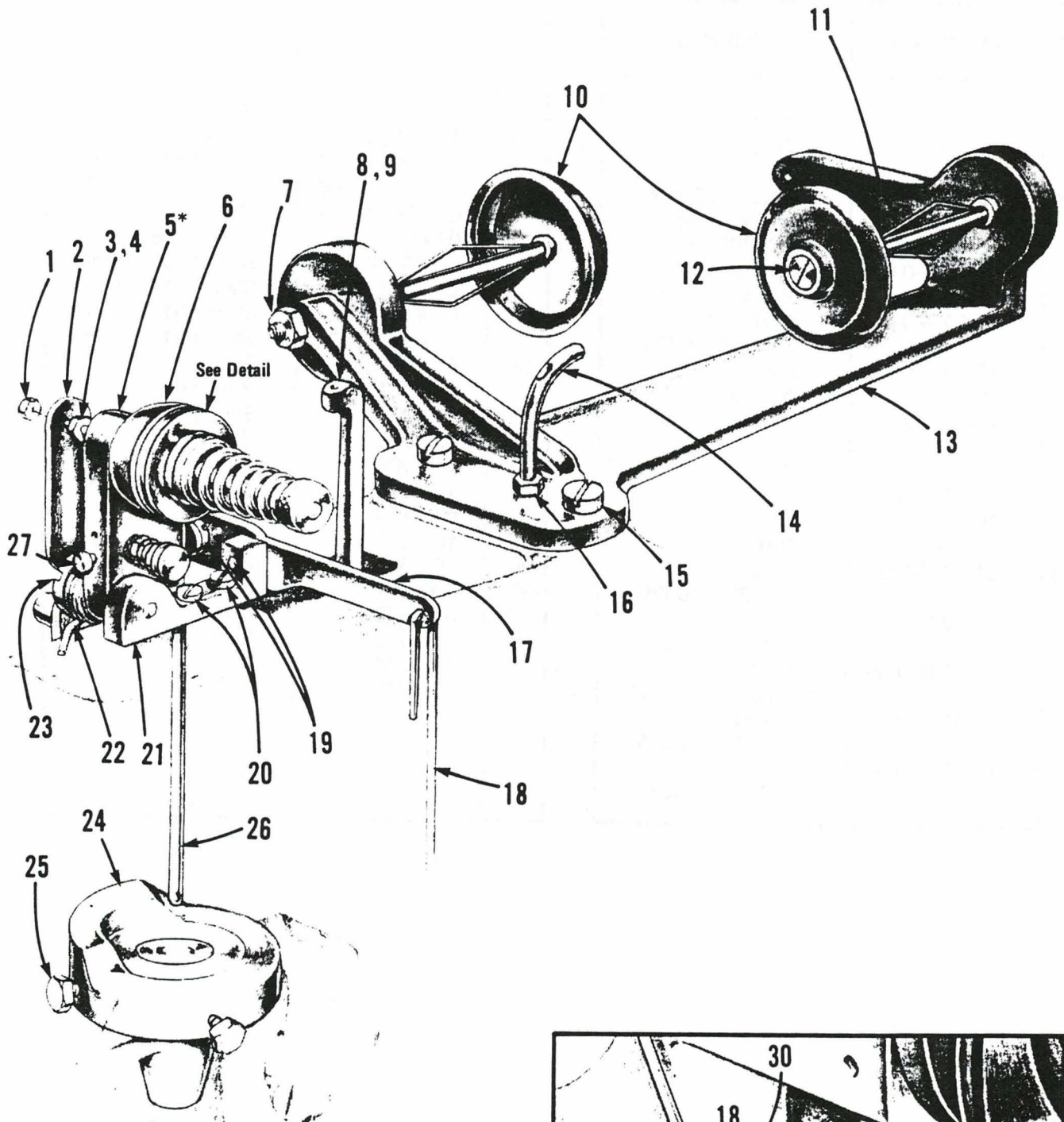

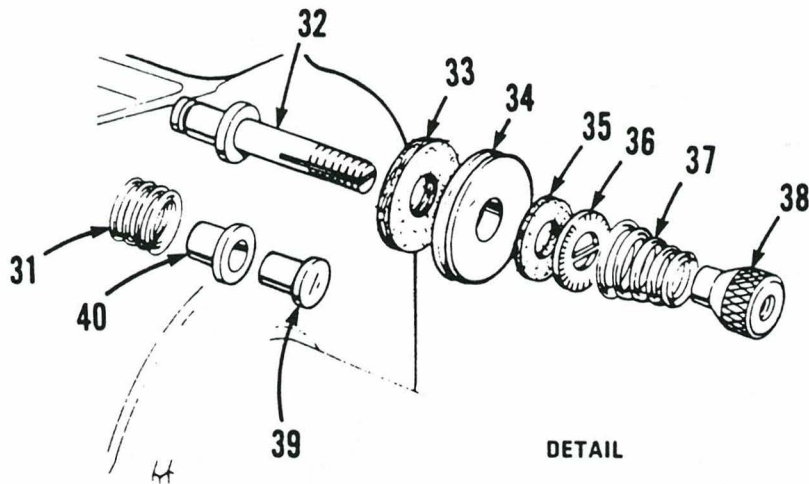

DET.	PART NUMBER	DESCRIPTION
1	01-3025	Nut
2	10-1178	Release Lever
3	01-2509	Screw
4	01-6499	Rod
5	10-1158-1-050	Tension Arm Asm.
6	01-4074	Spacer
7	01-3007	Nut
8	01-7041	Bushing
9	10-1051-1	Lever
10	10-1139-2	Shield
11	10-1140-2	Spindle
12	01-2111	Screw
13	10-1135	Bracket
14	05-0043	Guide
15	01-2061	Screw
16	01-3001	Nut
17	10-1177	Lever
18	10-1083	Link
19	01-1112	Screw
20	01-2039	Screw
21	10-1159-1	Bracket
22	01-5163	Spring
23	01-1114	Screw
24	10-1160	Cam
25	01-2362	Screw
26	01-6334	Rod
27	01-2001	Screw

28	01-2329	Screw
29	10-1120	Link
30	10-1113	Three Fork Lever
31	01-5002	Spring
32	01-1113	Stud
33	10-1077	Felt Washer
34	10-1078-1	Roller
35	10-1004	Felt Washer
36	10-1003	Washer
37	01-5603	Spring
38	10-4030	Nut
39	10-1008	Guide
40	10-1009	Bushing

DET.	PART NUMBER	DESCRIPTION
1	01-7041	Bushing
2	10-1051-1	Takeup Lever
3	01-5005-0-001	Spring Asm.
5	01-6014	Anchor
6	10-1122-0-997	Roll .010"
	10-1122-0-998	Roll #2
	10-1122-0-999	Roll #1
	10-1122-0-017	Roll XAF
7	10-1063	Timing Core
8	14-1064-1	Cam Follower
9	10-1066-2	Pivot Screw
10	10-1062	Jam Plug
11	10-1054	Pivot Bushing
12	10-1055	Pivot Screw

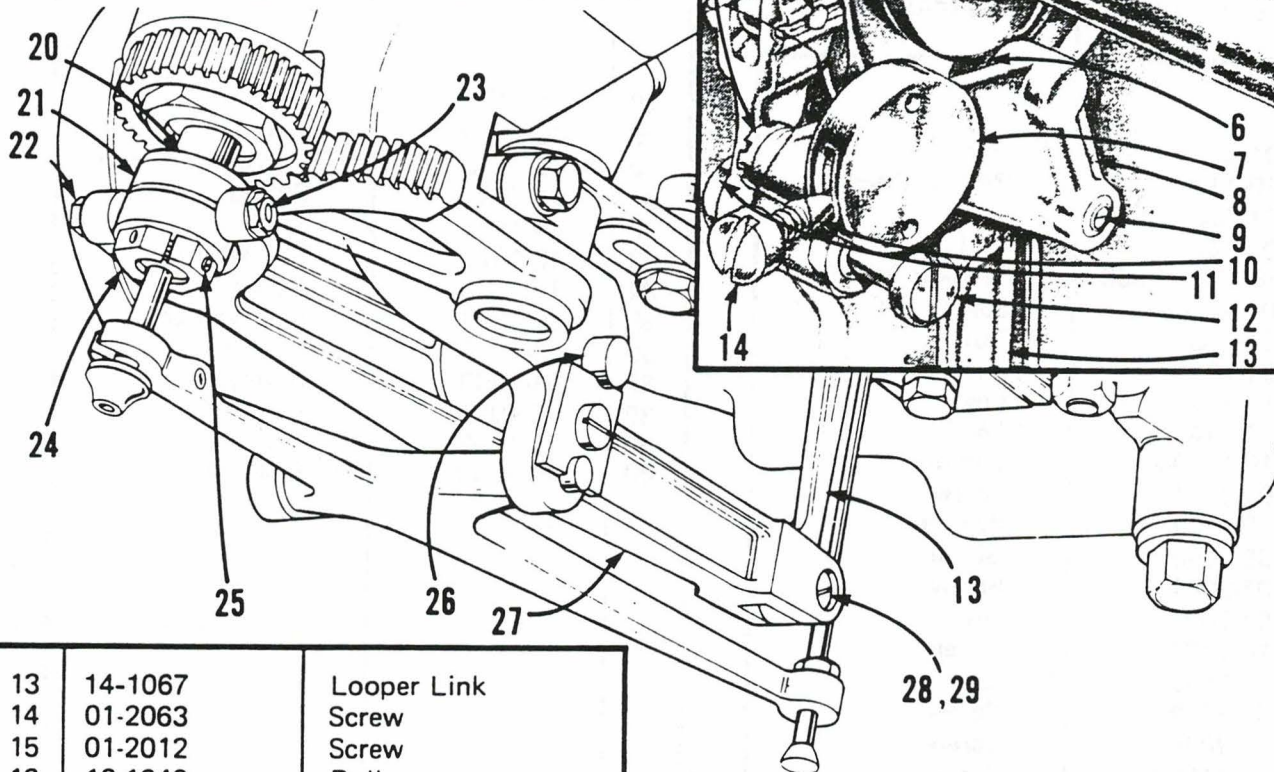
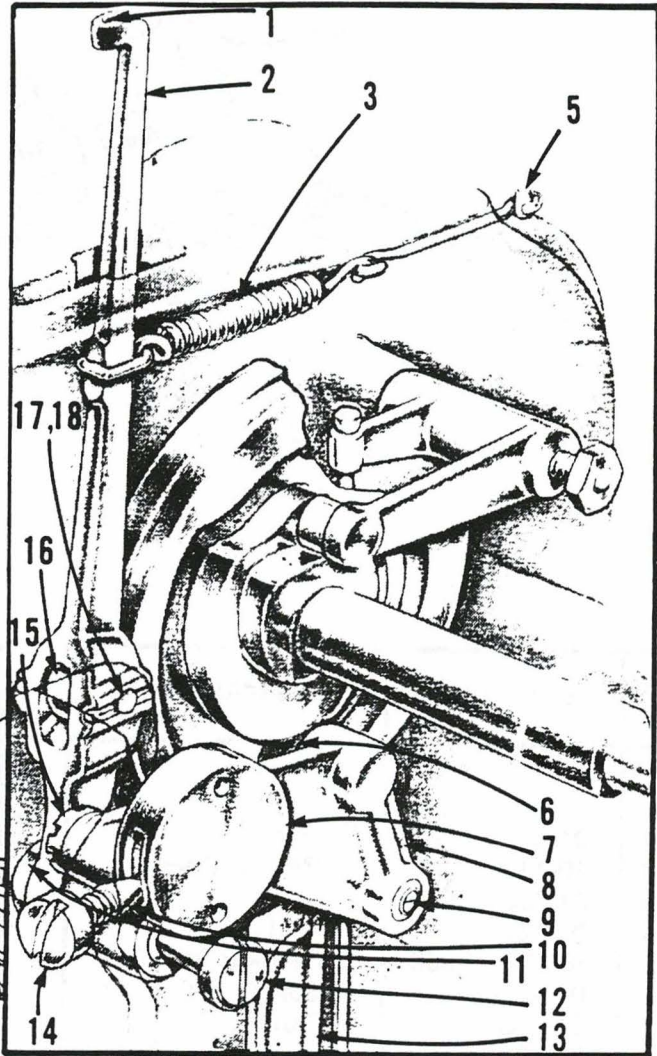

13	14-1067	Looper Link
14	01-2063	Screw
15	01-2012	Screw
16	10-1040	Roll
17	10-1052	Stud
18	10-1053	Cotter Pin
20	01-4010	Washer
21	10-4024	Bearing Ring
22	01-3020	Nut
23	10-3007	Bearing
24	10-4023	Collar
25	01-2007	Clamp Screw
26	10-3005	Pivot Pin

27	14-3006-0-150 14-3006-0-200 14-3006-0-165	Looper Lever, C.A. Looper Lever, C.B. Looper Lever, W. Bite (AF-CA-R-RE-MB)
28	10-3008	Screw
29	01-3010	Nut

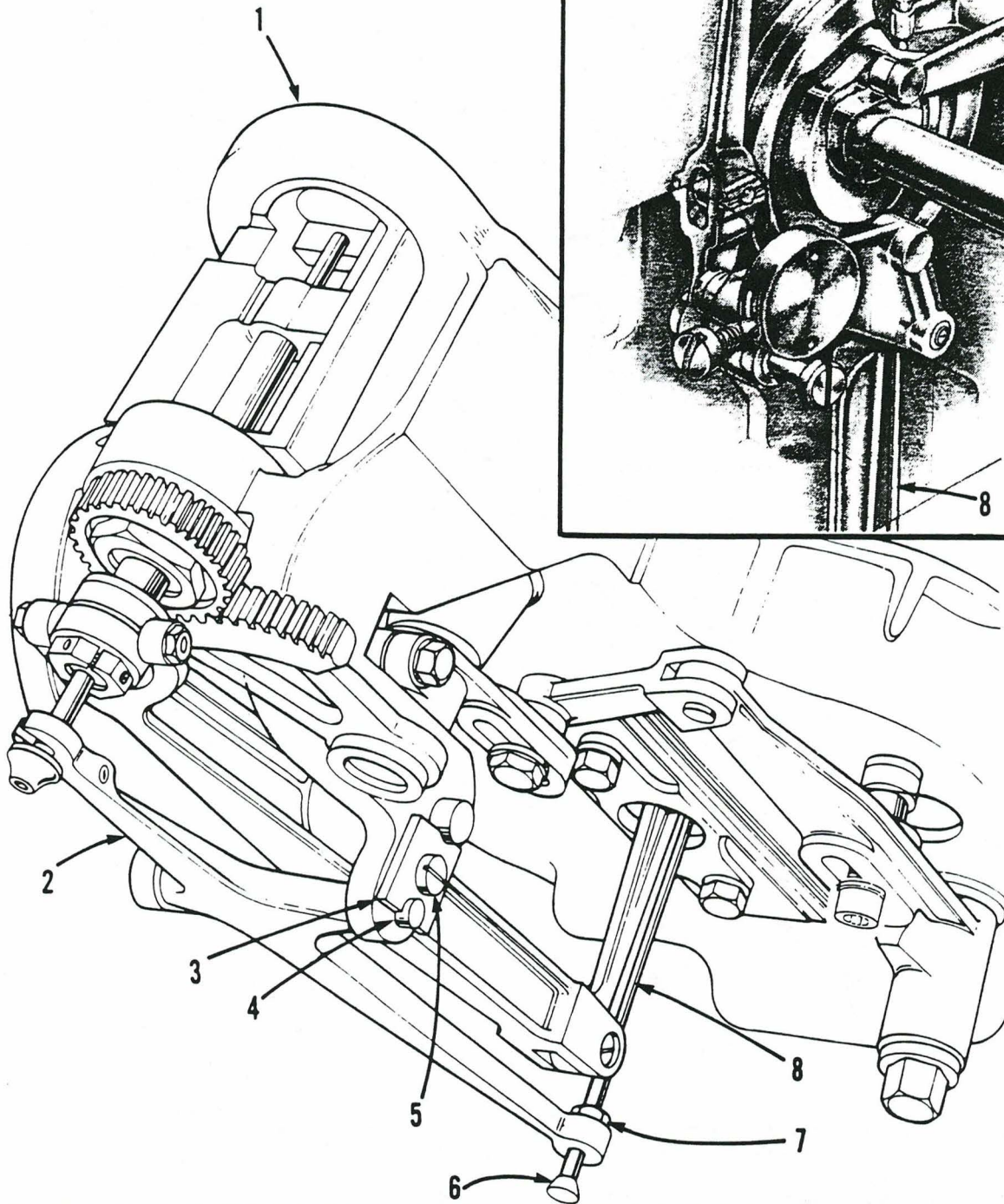

DET.	PART NUMBER	DESCRIPTION
1	10-3001-2	Cam Case
2	14.3004	Spreader Lever
3	10-3002	Locking Plate
4	10-3003	Pivot Pin
5	01-2041	Screw
6	10-1061-1	Ball Tip

7	01-3025	Nut
8	10-1060-2	Spreader Link
9	14-1058	Spreader Cam Follower (Includes Stud & Roll)
10	10-1059	Pivot Pin
11	01-3005	Nut
12	10-1091-0-000	Stitch Cam & Shaft Asm.

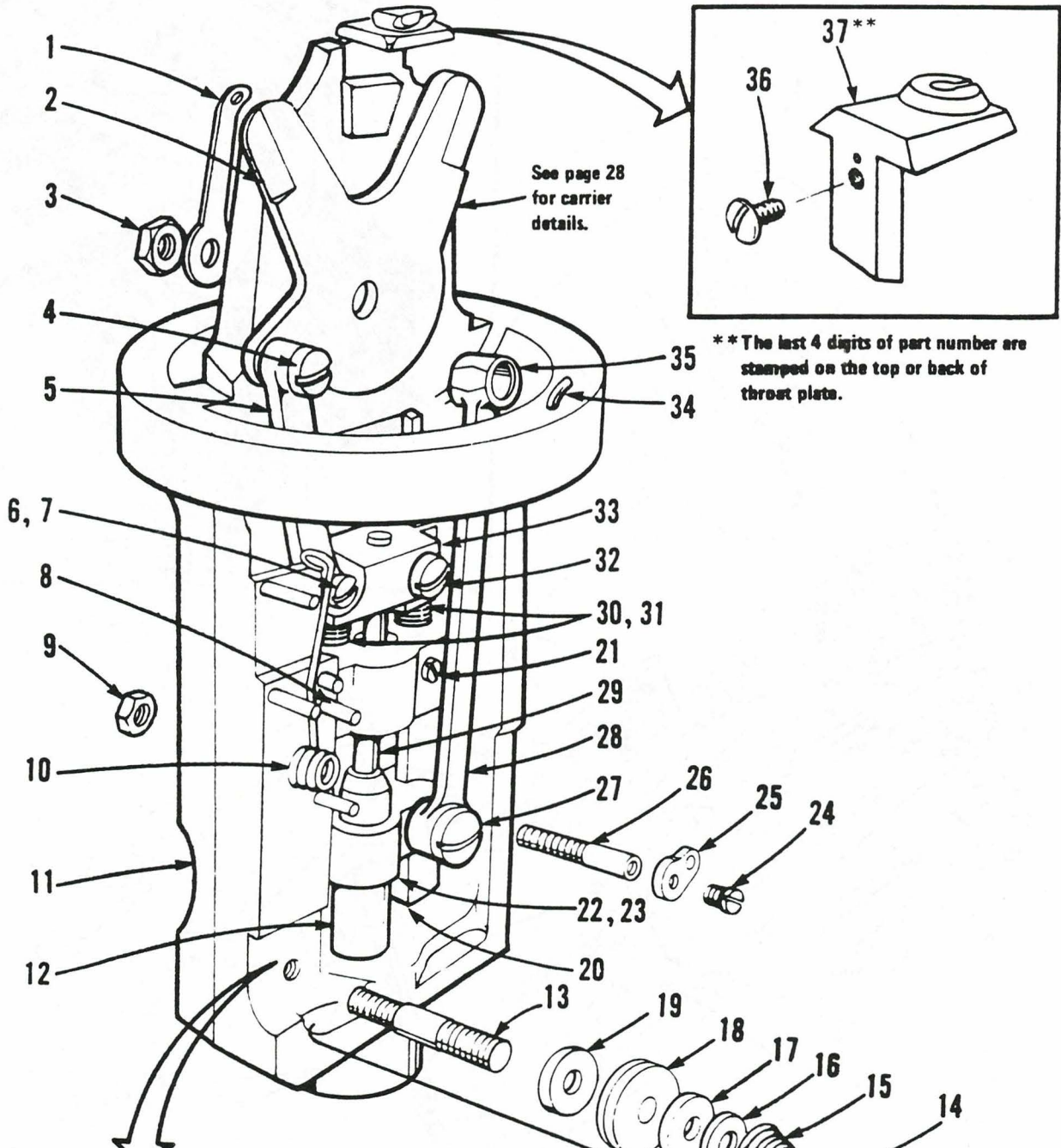

See page 28 for carrier details.

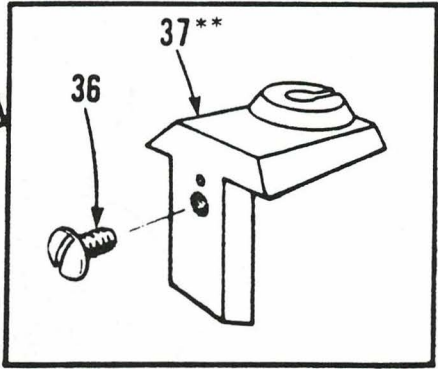

\*\*The last 4 digits of part number are stamped on the top or back of throat plate.

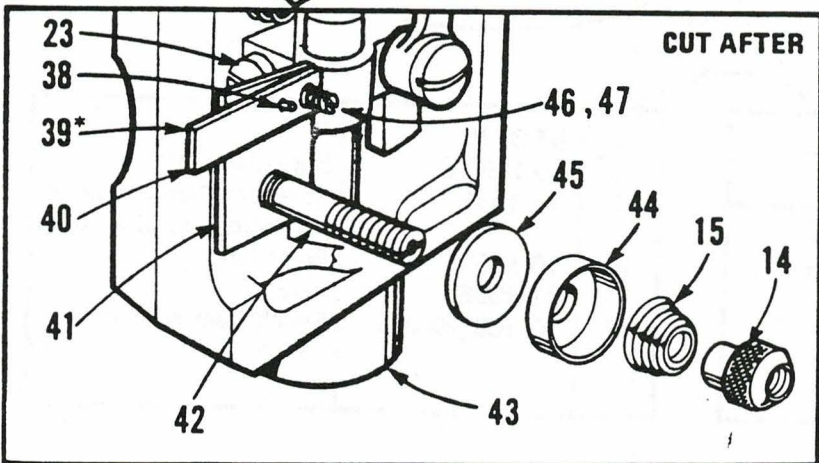

THROAT PLATES		
MODELS (Prod. #)	STYLE	PART NO.
AF-CA-R-RE (016)	R-CA	10-4012-0-001
AF-CA-R-RE MB (017)	W-CA	10-4012-0-002
AF-CB-R-FE (022)	R-CB	10-4012-0-004
AF-CB-R-RE (023)	R-CB	10-4012-0-004
AF-CB-RL-ME (024)	R-CB	10-4012-0-004
AF-CB-RL-LE (025)	R-CB	10-4012-0-004
AF-CB/CA-R-RE (030)	R-CB	10-4012-0-004
AF-CB-R-ME/LE-HH (026)	R-CBT	10-4012-0-008
AF-CA-XL-LE (019)	RX-CA	10-4012-0-020

21	01-2013	Screw
22	10-4021	Looper Crosshead
23	01-2024	Screw
24	01-2081	Screw
25	10-4036	Spring
26	10-4037	Stud
27	01-1006	Screw
28	10-4013	Looper Link
29	10-4020	Spreader Spindle
30	10-4019	Plunger
31	01-5026	Spring
32	01-2059	Screw
33	10-4018	Spreader Crosshead
34	01-6002	Pin
35	01-7022	Bushing
36	01-2056	Screw
37	See Chart	Throat Plate
38	01-6003	Pin
39	10-4033-0-050	Tension Plate Assembly
40	10-4028	Tension Plate
41	10-4033	Plate
42	10-4029	Stud
43	10-4001-1-150	Cut - After Race
44	10-4031	Heavy Disc
45	10-4032	Thin Disc
46	10-4034	Screw
47	01-5004	Spring

DET.	PART NUMBER	DESCRIPTION
1	10-4035	Cord Guide
2	14-4011-0-200	Spreader Wedge (C.B.)
	14-4011-0-150	Spreader Wedge (C.A.)
3	01-3005	Nut
4	10-4017	Screw
5	10-4015	Spreader Link
6	10-4016	Screw
7	01-4012	Washer
8	01-6018	Pin (used on C.B. only)
9	01-3001	Nut
10	01-5027	Spring
11	10-4001-1-200	Cut - Before Race
12	10-4022	Looper Spindle
13	10-4218-0-200	Stud
14	10-4030	Nut
15	01-5028	Spring
16	10-1003	Washer
17	10-1004	Felt Washer
18	10-1078	Solid Roller Tension
19	10-1077	Felt Washer
20	10-4026	Guide Plate

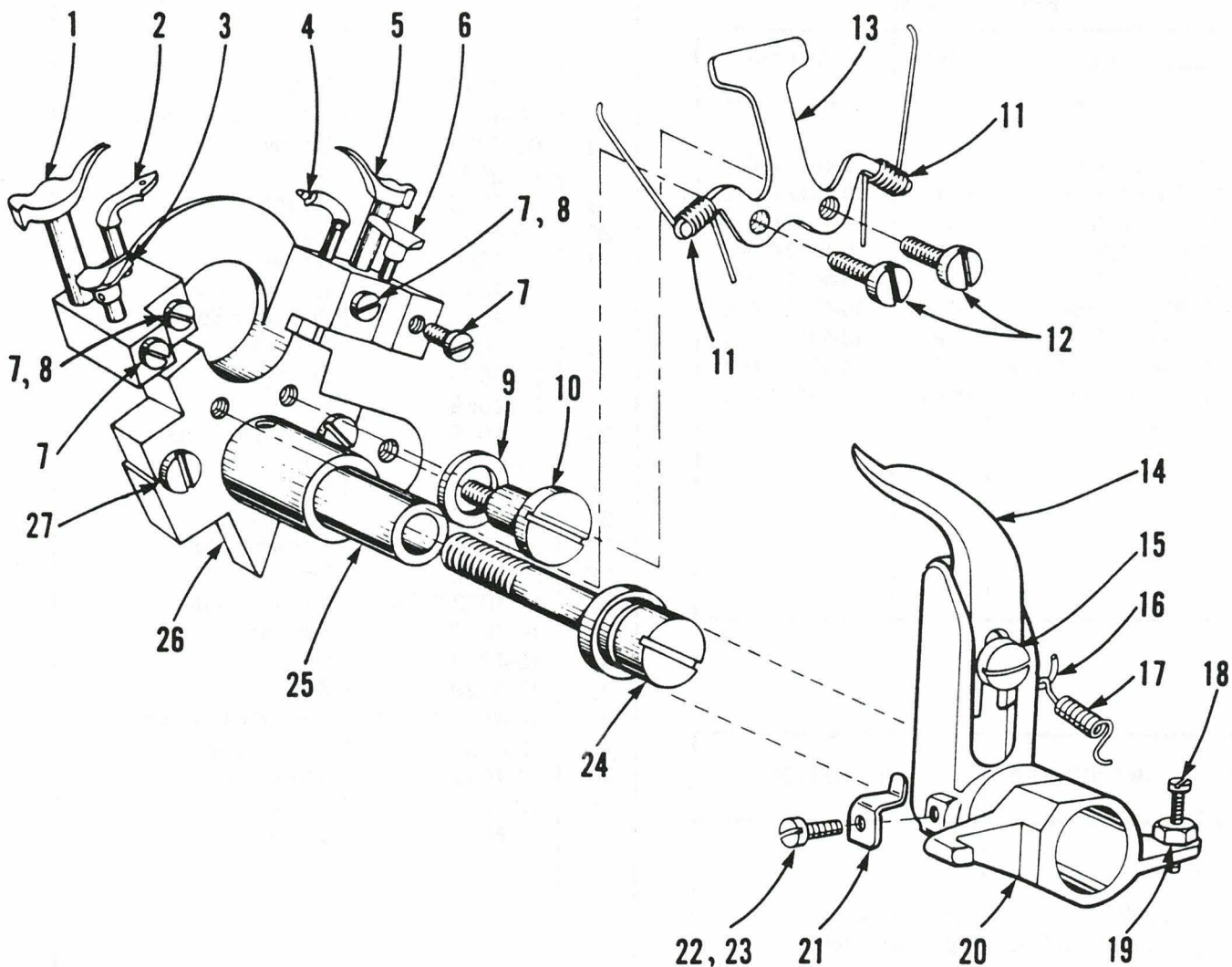

DET.	PART NUMBER	DESCRIPTION
1	10-4009	Forked Spreader
2	10-4005-2	Eye Looper
3	10-4007	Left Spreader Stop
4	10-4004	Blind Loop
5	10-4008	Right Spreader
6	10-4006	Right Spreader Stop
7	01-2001	Screw
8	10-4039	Felt Pad
9	01-4013	Washer
10	01-1006	Screw
11	01-5025	Spring, Left Hand
	01-5024	Spring, Right Hand
12	01-2073	Screw

13	10-4010-2	Needle Guard
14	10-4600	Knife
15	01-2081	Screw
16	01-6002	Anchor
17	01-5041	Spring
18	01-2361	Screw
19	01-3025	Nut
20	10-4202-0-100	Knife Holder
21	10-4203	Retaining Spring
22	01-2318	Screw
23	01-4015	Washer
24	14-4201	Stud
25	10-4003	Bushing
26	10-4002	Looper Carrier
27	01-2053	Screw

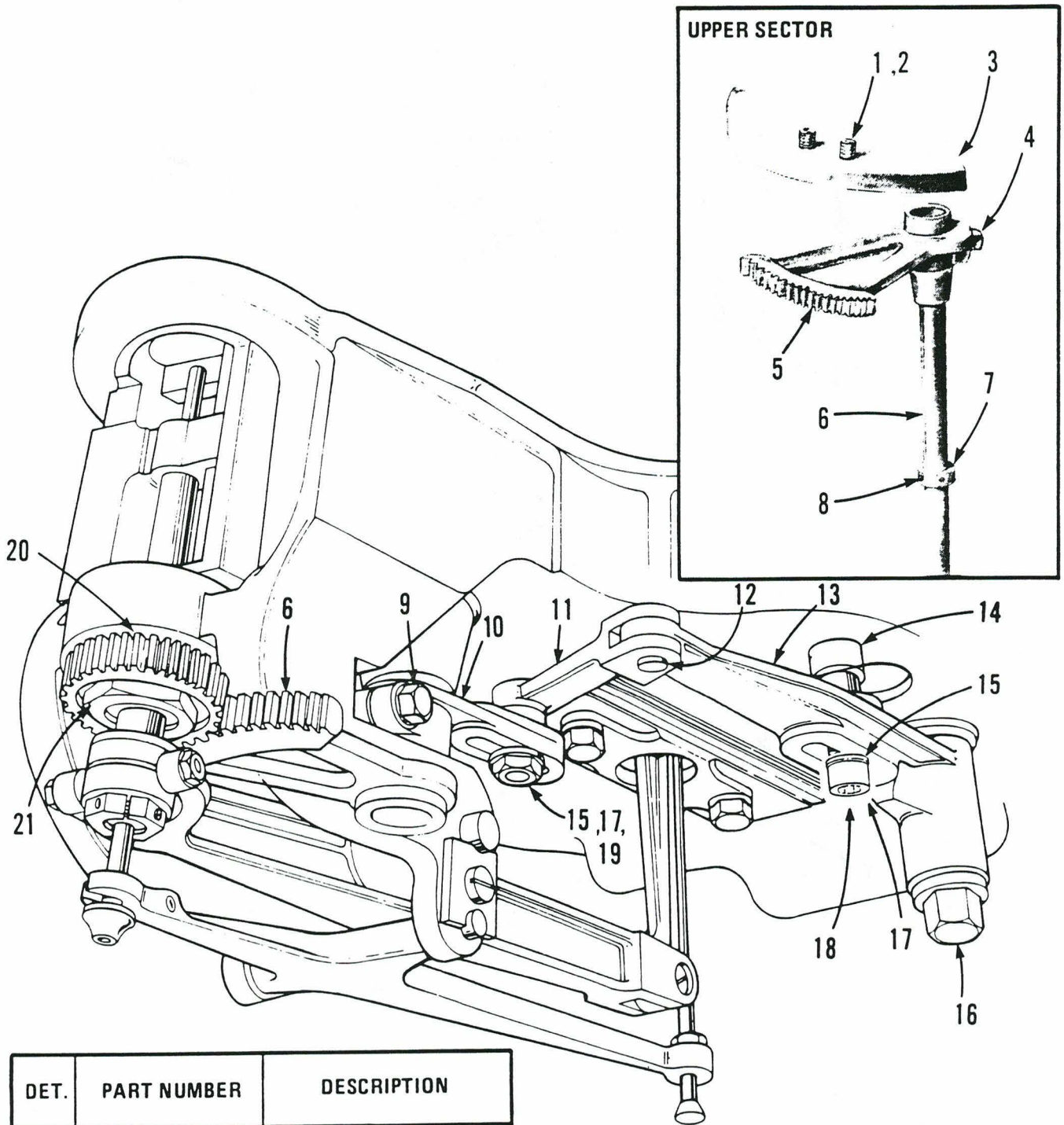

DET.	PART NUMBER	DESCRIPTION
1	01-2078	Screw
2	01-4018	Washer
3	10-1145-2	Shield
4	01-2014	Screw
5	10-1075-1	Upper Sector
6	10-3009	Lower Sector & Shaft
7	10-3010	Collar
8	01-2028	Screw
9	01-2016	Screw
10	10-3011	Lever
11	10-3012	Link

12	10-3026	Stud
13	10-3015-0-250	Sector Lever
14	10-3018	Roll
15	01-4503	Washer
16	10-3016	Stud
17	01-1395-0-004	Screw
18	14-3017	Stud
19	10-3013	Stud
20	10-4025	Gear
21	01-3018	Nut

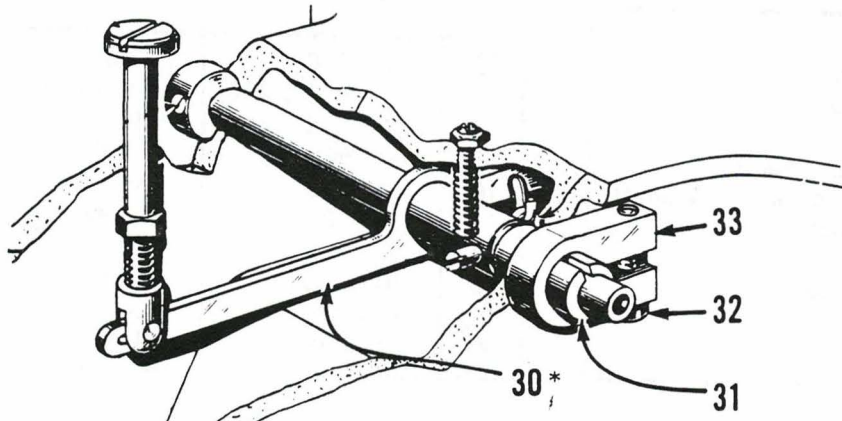
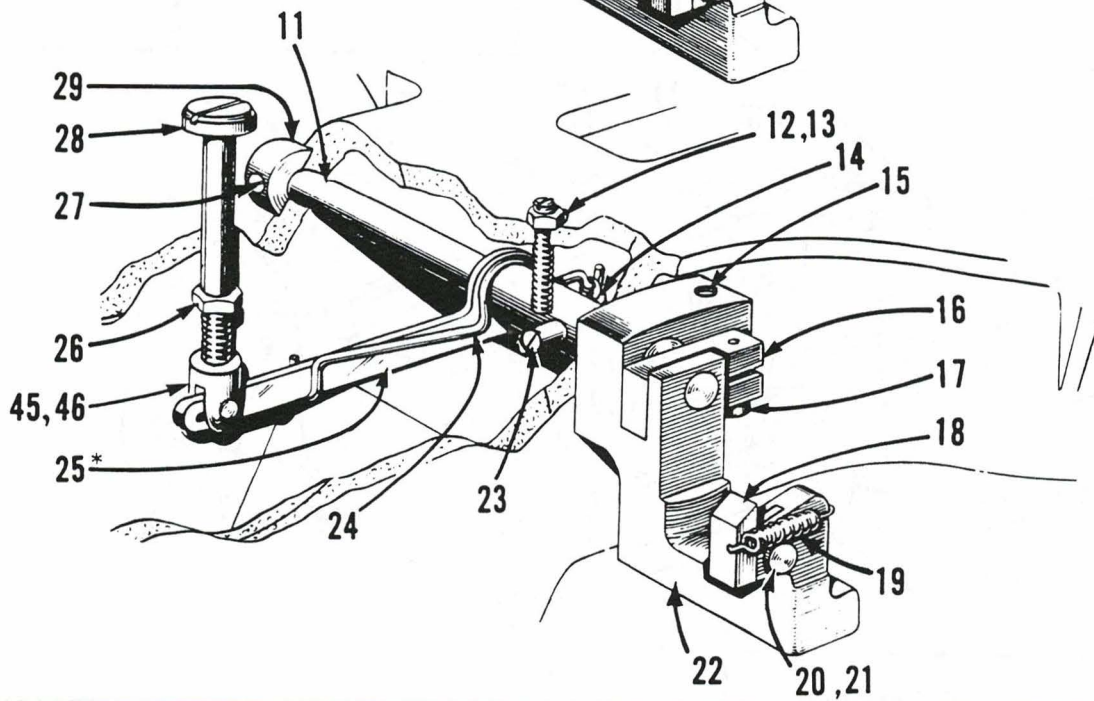
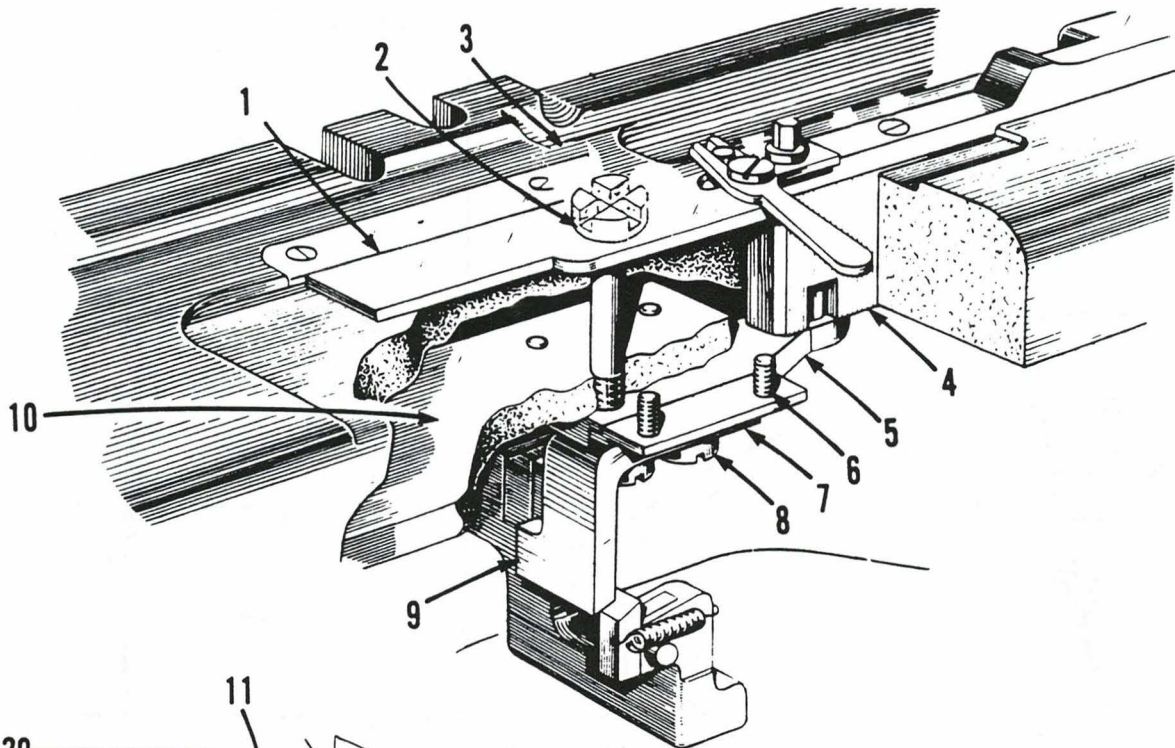

EXTRA LONG TRAVEL - CUT AFTER

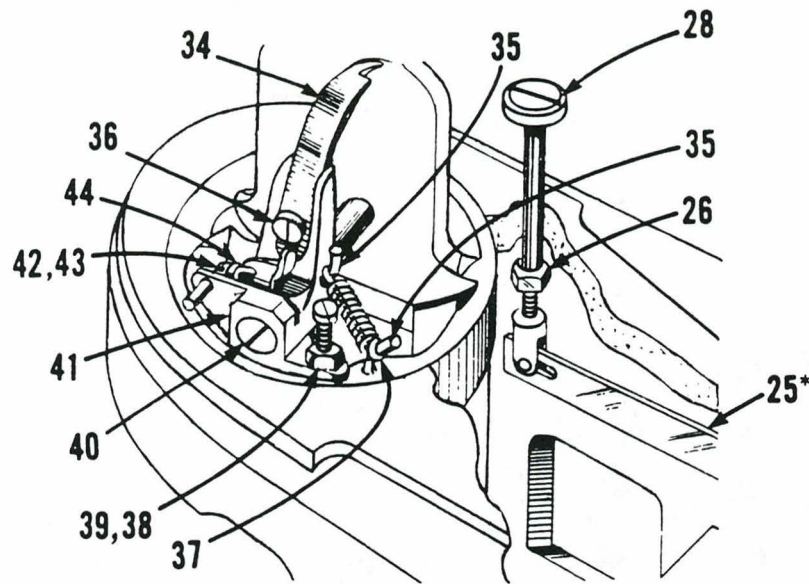

DET.	PART NUMBER	DESCRIPTION
1	10-2251-0-002	Length Plate AFCBRFE
	10-2251-1	Length Plate (Reg. Travel)
	10-2251-1-017	Length Plate (Reg. Long Travel)
	10-2251-0-001	Length Plate 7 mm
2	01-4006	Washer
3	14-2254	Adj. Bolt
4	10-2262	Block
5	10-2263	Link
6	01-2131	Screw
7	10-2264	Rail
8	01-2175	Screw
9	14-2069-0-050	Trip
10	10-2255-3-200	Flybar Cam Plate (CB-R)
	10-2255-2-150	Flybar Cam Plate (CA-R)
	10-2255-3-217	Flybar Cam Plate (Regular)
	10-2255-2-167	Flybar Cam Plate (XAF Travel)
11	14-5019-0-000	Shaft
12	01-2077	Screw
13	01-3005	Nut
14	01-5038	Spring
15	01-2171	Screw
16	14-3088	Clamp
17	01-2144	Screw
18	10-3089-2	Latch
19	01-5433	Spring
20	01-6528	Pivot
21	01-6368	Retaining Ring

22	14-3087	Actuator
23	10-3203	Stop
24	10-3086	Lever
25	10-3085-0-050	Lever
26	01-3016	Nut
27	01-2194	Screw
28	10-3206-1	Actuator
29	01-7435-1	Collar
30	10-3202-0-050	Lever Asm.
31	01-7438	Bushing
32	01-2024	Screw
33	10-3090	Clamp
34	10-4600	Knife
35	01-6002	Anchor
36	01-2081	Screw
37	01-5041	Spring
38	01-2361	Screw
39	01-3025	Nut
40	14-4201	Stud
41	10-4202	Trimmer Bracket
42	01-2318	Screw
43	01-4015	Washer
44	10-4203	Spring
45	10-3205	Clevis
46	01-6015	Pin

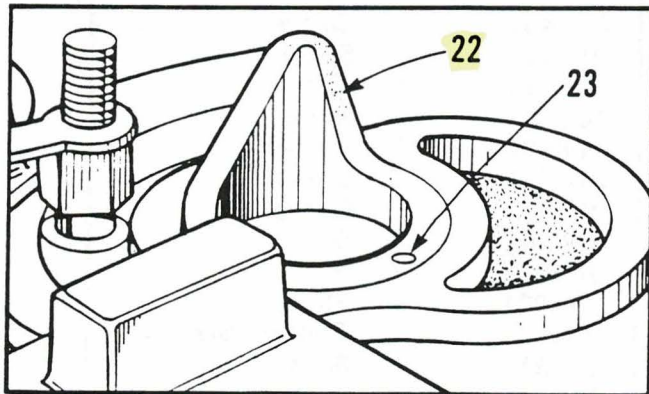
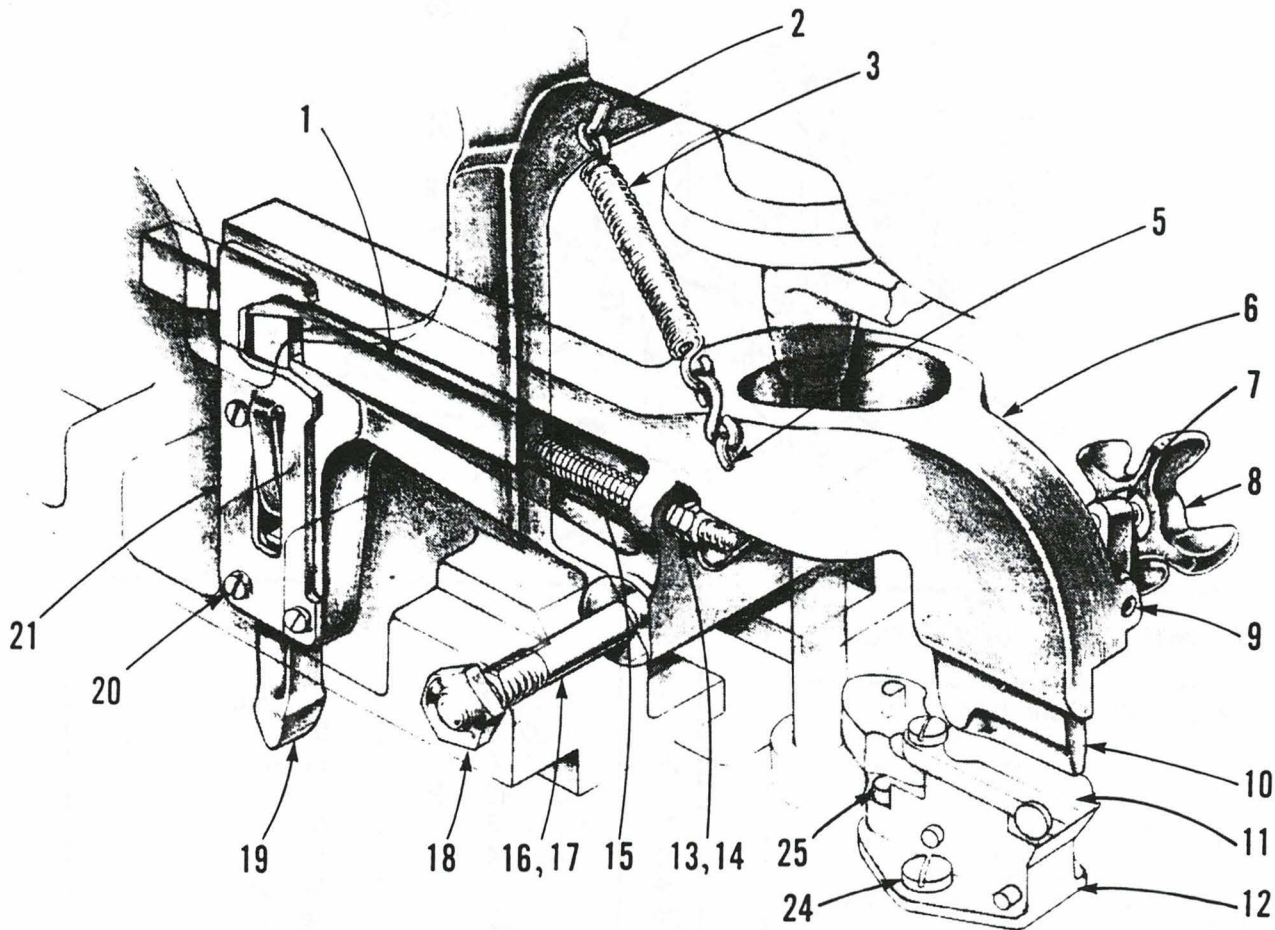

DET.	PART NUMBER	DESCRIPTION
1	10-1072	Pressure
2	01-6560	Anchor
3	01-5006-0-001	Spring Assembly
5	01-6006	Anchor
6	10-1154-0-050	Cutting Lever (C.B.)
	10-1068-1-050	Cutting Lever (C.A.)
7	10-1164	Clamp (C.B.)
	10-1163	Clamp (C.A.)

8	01-1023	Screw
9	01-6837	Pin (C.A.)
	01-6837-0-001	Pin (C.B.)
10	(See pgs. 34-36)	Cutting Steel
11	(See pgs. 34-36)	Knife
12	10-3070-0-017	Knife Holder (Long & Extra Long Travel)
	10-3070-0-250	Knife Holder (Regular Travel)
13	01-3001	Nut
14	01-4001	Washer
15	01-5061	Spring
16	10-1074	Pivot Stud, Left
17	10-1074-0-250	Pivot Stud, Right
18	01-3006	Nut
19	10-1071-1-023	Cam Follower(CB/CA)
	10-1071-2	Cam Follower
20	01-2013	Screw
21	10-1073-1	Cover Plate
22	10-3062-1	Cutting Cam
23	01-6983-0-001	Pin
24	01-2039	Screw
25	01-2038	Screw

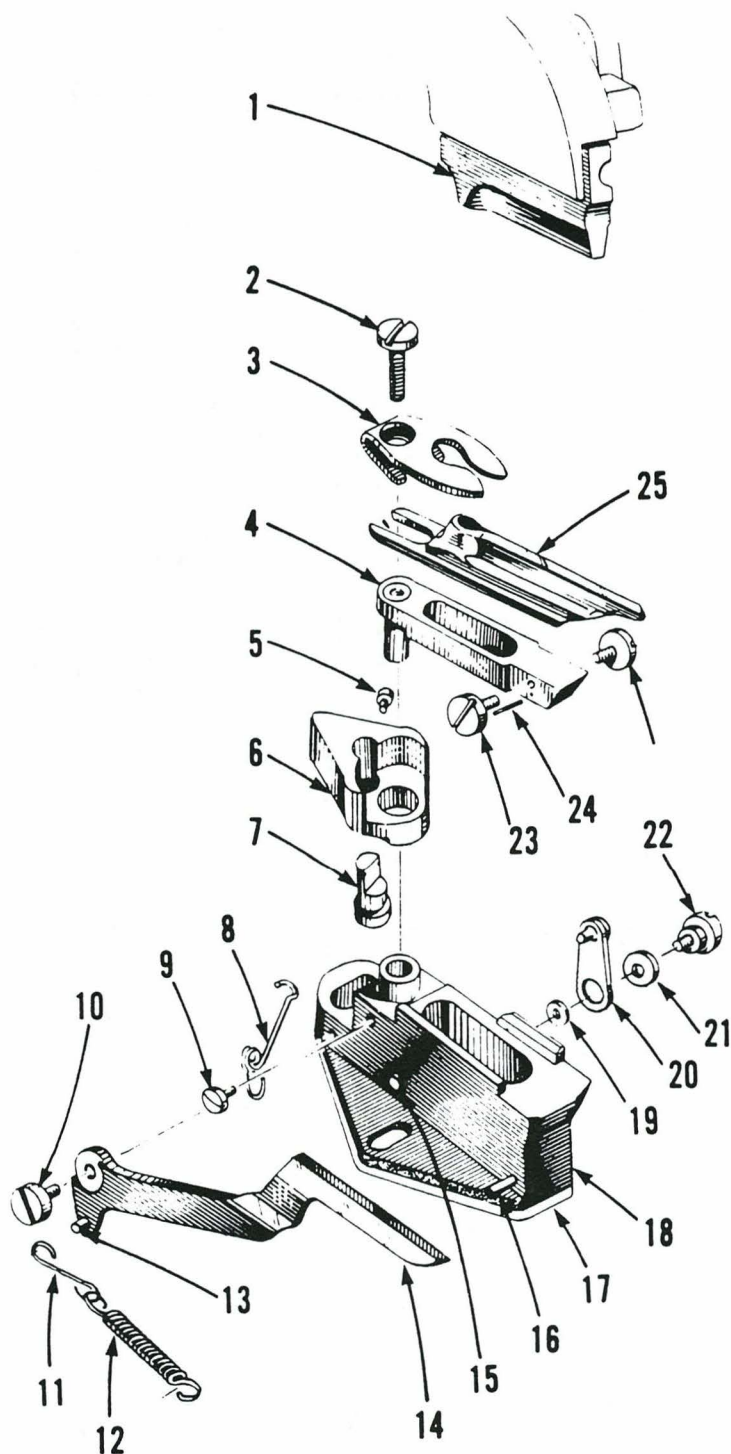

DET.	PART NUMBER	DESCRIPTION
1	(See pgs. 34-36)	Cutting Steel
2	01-2039	Screw
3	10-3074-0-011	Cloth Lifter (L.T.) (All C.B. models)
4	10-3071-0-017	Knife Pad (Extra Long Travel)
	10-3071-1-250	Knife Pad (Regular & Long Travel)
5	01-2001	Screw (used only on AF-CB-RL-ME & LE)
6	(See Chart)	Spreading Block
7	14-3002	Stud (CA only)
8	01-5166	Spring (C.B. Reg. Long Travel only)
9	01-2034	Screw (C.B. Reg. Long Travel only)
10	01-1131	Screw (CB only)
11	10-3261	Link (CB only)
12	01-5029	Spring (CB only)
13	01-6099	Pin
14	10-3260-1	Cloth Lifter (CB only)
15	01-6328	Stop Pin
16	01-6005	Anchor Pin
17	10-3075-1-992	Shim (.016")
	10-3075-1-993	Shim (.005")
18	10-3070-0-017	Knife Holder (Long & Extra Long Travel)
	10-3070-0-250	Knife Holder (Regular Travel)
19	01-4029	Washer
20	01-5173	Spring
21	01-4003	Washer
22	01-1130	Screw (CA only)
23	01-2102	Screw
24	01-6036	Pin
25	(See pgs. 34-36)	Knife

SPREADING BLOCKS	
10-3067-3-253	AF-CA-R-RE/NE & MB
10-3067-4-254	AF-CB-R-FE, RE, ME, LE
10-3067-4-167	AF-CA-XL-LE
10-3067-5-217	AF-CB-RL-ME/LE/NE



Knives and Cutting Steels are stamped with the last four digits of its part number. The Cutting Steels are also stamped with its size. To reorder original knives or cutting steels, give first six digits of part number, e.g. 10-3072 or 10-1069 plus the last four digits stamped on the original part.

To order knives or cutting steels, other than those supplied with machine, refer to the following listing.

Legend is furnished to explain abbreviation used and to supply other information needed to order new knives or cutting steels.

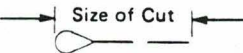
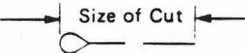
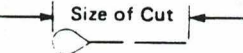
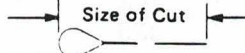
LEGEND	
<p><b>MODELS</b></p> <p>AF-Adjustable Flybar                      CA-Cut After                      CB-Cut Before                      CT-Cord Trim                      CrB-Cross Bar                      RdE-Round Eyelet                      CO-Cross Oval                      ED-Edger</p>	<p><b>TRAVEL</b></p> <p>R-Regular                      RL-Regular/Long                      L-Long                      XL-Extra Long</p> <p><b>MISCELLANEOUS</b></p> <p>HH-Hand Hole                      MB-Medium Bite</p>

EYE STYLES (shown in actual size)	
 RE = Regular Eye	 FE = French Eye
 ME = Medium Eye	 LE = Large Eye

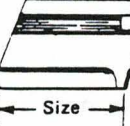
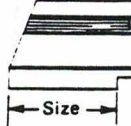
KNIVES	
 EYE	 NO-EYE
CUTTING STEELS	
 Size	 Size

KNIVES		
MODELS	SIZE & STYLE	PART NO.
<b>ADJUSTABLE FLYBAR</b>		10-3072-
AF-CA-R-RE	1-1/4"-NE 1-1/4"-RE	-0-023 -0-024
AF-CA-R-RE-MB	1-1/4"-NE 1-1/4"-RE	-0-023 -0-024
AF-CA-XL-LE	2"-LE 2"-NE	-0-014 -0-015
AF-CB-R-FE	1-1/4"-FE 1-1/4"-NE	-0-033 -0-023
AF-CB-R-RE	1-1/4"-RE 1-1/4"-NE	-0-029 -0-023
AF-CB-RL-ME	1-1/4"-RE 1-1/4"-NE	1-028 0-023
AF-CB-RL-LE	1-3/4"-LE 1-3/4"-NE	1-010 1-013
AF-CB-R-ME/LE-HH	1-1/4"-RE 1-1/4"-NE	1-028 0-023
AF-CB/CA-R-RE	1-1/4"-RE 1-1/4"-NE	0-024 0-023
<b>OPEN END BUTTONHOLE</b>		10-3072-
CA-R-RE	1-1/2"-RE 1-1/2"-NE	0-036 0-003
CA-R-ME-HH	1-1/2"-FE 1-1/2"-NE	0-044 0-003
CB-R-FE	1-1/2"-FE 1-1/2"-NE	0-044 0-003
CB-R-RE	1-1/2"-RE 1-1/2"-NE	0-043 0-003
CB-L-ME	1-3/4"-ME 1-3/4"-NE	1-009 1-013
CB-R-ME/LE-HH	1-1/2"-ME 1-1/2"-NE	2-046 0-003
CB-R-ME	1-1/2"-ME 1-1/2"-NE	2-046 0-003
CB/CA-R-RE	1-1/2"-RE 1-1/2"-NE	0-036 0-003

Page	Detail	Change	To	Description
35	Round Eyelet		1/32" RdE 3/32" RdE 1/4" RdE 3/8" RdE 7/16" RdE 1/2" RdE	(Add the following): 10-3553-0-001 10-3553-0-003 10-3553-0-008 10-3553-0-012 10-3553-0-014 10-3553-0-016
35	Cutting Steel Adjustable Flybar		1/2" 5/8" 3/4" 7/8" 1" 1-1/8" 1-1/4" 1/2" No Eye 5/8" 3/4" 7/8" 1" 1-1-8" 1-1/4"	(Add the following under AF-CA-R-RE) 10-1069-0-001 10-1069-0-002 10-1069-0-003 10-1069-0-004 10-10690-005 10-1069-0-006 10-1069-0-007 10-1069-0-010 10-1069-0-011 10-1069-0-012 10-1069-0-013 10-1069-0-014 10-1069-0-015 10-1069-0-016
35		1" + 0-052 1-1/4" -0-054 2" -0-060 2" -NE-0-072	5/8" -0-049 3/4" -0-050 7/8" -0-051 1" 0-052 1-1/8" 0-053 1-1/4" 0-054 1-3/8" 0-055 1-1/2" 0-056 1-5/8" 0-057 1-3/4" 0-058 1-7/8" 0-059 2" 0-060	(Eye Cutting Steels)
			5/8" -NE-0-061 3/4" -NE-0-062 7/8" -NE-0-063 1" -NE-0-064 1-1/8" -NE-0-065 1-1/4" -NE-0-066 1-3/8" -NE-0-067 1-1/2" -NE-0-068 1-5/8" -NE-0-069 1-3/4" -NE-0-070	(No Eye Cutting Steels)
35			1-7/8" -NE-0-071 2" NE-0-072	
		3/4" -0-075 1" -0-077 1-1/4"-0.079 1-1/4-NE-0-087	1/2" -0-073 5/8" -0-074 3/4" -0-075 7/8" -0-076 1" -0-077	(Under Cutting Steels, at AF-CB-R-FE and at AF-CB-R-RE)

Page	Detail	Change	To	Description (remarks)
			1-1/8" -0-078 1-1/4" -0-079 5/8" -NE-0-082 3/4" -NE-0-083 7/8-NE-0-084 1" -NE-0-085 1-1/8" NE-0-086 1-1/4" NE-0-087	
35		3/4" -0-075 1" -0-077 1-1/4"-0-079 1-1/4"NE-0-087	5/8" -0-049 3/4" 0-050 7/8" 0-051 1" 0-052 1-1/8"-0-053 1-1/4"-0-054 1-3/8"-0-055 1-1/2"-0-056 1-5/8"-0-057 1-3/4"-0-058 5/8"NE-0-061 3/4"NE-0-062 7/8"NE-0-063 1"NE-0-064 1-1/8"NE-0-065 1-1/4"NE-0-066 1-3/8"NE-0-067 1-1/2"NE-0-068 1-5/8"NE-0-069 1-3/4"NE-0-070	(Under Cutting Steels, at AF-CB-RL-ME & at AF-CB-RL-LE)
		3/4" -0-075 1" -0-077 1-1/4"-0-079 1-1/4"NE-0-087	1/2" -0-073 5/8" -0-074 3/4" -0-075	
35			1" -0-077 1-1/8"-0-078 1-1/4"-0-079 5/8"NE-0-082 3/4"NE-0-083 7/8"NE-0-084 1"NE-0-085 1-1/8"NE-0-086 1-1/4"NE-0-087	
36		1" -0-005 1-1/8"-0-006 1-1/2"-0-009 1"NE-0-014	1/2" -0-001 5/8" -0-002 3/4" -0-003 7/8" -0-004 1" -0-005 1-1/8"-0-006 1-1/4"-0-007 1-3/8"-0-008 1-1/2"-0-009 1/2"NE-0-010 5/8"NE-0-011 3/4"NE-0-012 7/8"NE-0-013 1"NE-0-014 1-1/8"NE-0-015 1-1/4"NE-0-016 1-1/2"NE-0-017	(At "Open End Buttonholes", combine CA-R-RE & CB/CA-R-RE and eliminate CB/CA-R-RE and expand as follows:)

Page	Detail	Change	To	Description (remarks)
36	Combine	CA,R-ME-HH CB-R-FE CB-R-RE CB-R-ME-LE-HH CB-R-ME (or MRE)	and change as follows:  1/2" -0-073 5/8" -0-074 3/4" -0-075 7/8" -0-076 1" -0-077 1-1/8"-0-078 1-1/4"-0-079 1-3/8"-0-080 1-1/2"-0-081 5/8"NE-0-082 3/4"NE-0-083 7/8"NE-0-084 1" NE-0-085 1-1/8"NE-0-086	(Combine)
			1-1/4"NE-0-087 1-3/8"NE-0-088 1-1/2"NE-0-089	
36		<u>At CB-L-ME:</u> 1" -0-052 1-1/8" -0-053 1-3/4" -0-058 1"-NE-0-064 1-3/4"-NE-0-070	5/8" -0-049 3/4" -0-050 7/8" -0-051 1" -0-052 1-1/8"-0-053** 1-1/4" -0-054 1-3/8"-0-055* 1-1/2"-0-056*	*These may not be available.  Order next larger or higher number and grind off front.



MODELS	SIZE & STYLE	PART NO.
<b>CORD TRIM</b>		10-3072-
CT-CA-9/16"-RE CT-CA-5/8"-RE CT-CA-5/8"-LE CT-CA-3/4"-RE CT-CA-7/8"-RE	9/16"-RE 5/8"-RE 5/8"-LE 3/4"-RE 7/8"-RE	0-058 0-059 0-067 0-060 0-062
<b>CROSS BAR MODELS</b>		10-3072-
CrB-CA-5/8"-ME CrB-CA-7/8"-ME CrB-CA-1"-ME CrB-CA-1-1/8"-ME CrB-CA-1-1/4"-ME	5/8"-ME 7/8"-ME 1"-ME 1-1/8"-ME 1-1/4"-ME	0-078 0-080 0-083 0-082 0-065
<b>ROUND EYELET</b>		10-3553-
RdE-S  Rd-E-M	1/16"-RdE 1/8"-RdE 5/32"-RdE  5/32"-RdE 3/16"-RdE 5/16"-RdE 11/32"-RdE	0-002 0-004 0-005  0-005 0-006 0-010 0-011
<b>CROSS OVAL</b>		10-3606-
Cross Oval	3/8"-CO 1/2"-CO 9/16"-CO 5/8"-CO 3/4"-CO	0-000 0-000 0-000 0-000 0-000
<b>EDGERS</b>		10-3072-
Cut-Before Cut-After	2"-ED-R 2 5/16"-ED	0-068 0-070

CUTTING STEELS		
MODEL	SIZE & STYLE	PART NO.
<b>ADJUSTABLE FLYBAR</b>		10-1069-
AF-CA-R-RE	3/4" 1" 1-1/4" 1-1/4"-NE	0-003 0-005 0-007 0-016
AF-CA-RE-MB	3/4" 1" 1-1/4"-NE	0-003 0-005 0-016
AF-CA-XL-LE	1" 1-1/4" 2" 2"-NE	0-052 0-054 0-060 0-072
AF-CB-R-FE	3/4" 1" 1-1/4" 1-1/4"-NE	0-075 0-077 0-079 0-087
AF-CB-R-RE	3/4" 1" 1-1/4" 1-1/4"-NE	0-075 0-077 0-079 0-087
AF-CB-RL-ME	1" 1-1/8" 1-3/4" 1-3/4"-NE	0-052 0-053 0-058 0-070
AF-CB-RL-LE	1" 1-1/8" 1-3/4" 1-3/4"-NE	0-052 0-053 0-058 0-070
AF-CB-R-ME/LE-HH	3/4" 1" 1-1/4" 1-1/4"-NE	0-075 0-077 0-079 0-087
AF-CB/CA-R-RE	3/4" 1" 1-1/4" 1-1/4"-NE	0-003 0-005 0-007 0-016

MODELS	SIZE & STYLE	PART NO.
<b>OPEN END BUTTONHOLE</b>		10-1069-
CA-R-RE	1" 1-1/8" 1-1/2" 1"-NE	0-005 0-006 0-009 0-014
CB/CA-R-RE	1" 1-1/8" 1-1/2" 1"-NE	005 006 009 014
CA-R-ME-HH	1" 1-1/8" 1-1/2" 1"-NE	0-077 0-078 0-081 0-085
CB-R-FE	1" 1-1/8" 1-1/2" 1"-NE	0-077 0-078 0-081 0-085
CB-R-RE	1" 1-1/8" 1-1/2" 1"-NE	0-077 0-078 0-081 0-085
CB-L-ME	1" 1-1/8" 1-3/4" 1"-A-NE 1-3/4"-A-NE	0-052 0-053 0-058 0-064 0-070
CB-R-ME/LE-HH	1" 1-1/8" 1-1/2"	0-077 0-078 0-081
CB-R-ME	1" 1-1/8" 1-1/2" 1"-B-NE	0-077 0-078 0-081 0-085

MODELS	SIZES & STYLE	PART NO.
<b>CORD TRIM</b>		10-1069-
CT-CA-9/16"-RE	9/16"-CT	0-019
CT-CA-5/8"-RE	5/8"-CT	0-020
CT-CA-5/8"-LE	5/8"-CT	0-020
CT-CA-3/4"-RE	3/4"-CT	0-021
CT-CA-7/8"-RE	7/8"-CT	0-022
<b>CROSS BAR</b>		10-1069-
CrB-CA-5/8"-ME	5/8"-CrB	0-145
CrB-CA-7/8"-ME	7/8"-CrB	0-030
CrB-CA-1"-ME	1"-CrB	0-151
CrB-CA-1-1/8"-ME	1-1/8"-CrB	0-149
CrB-CA-1-1/4"-ME	1-1/4"-CrB	0-007
<b>ROUND EYELET</b>		10-1550-
RdE-S	1/16"-RdE 1/8"-RdE 3/16"-RdE	0-002 0-004 0-006
RdE-M	3/16"-RdE 5/16"-RdE 11/32"-RdE	0-006 0-010 0-011
<b>CROSS OVAL</b>		10-1600-
3/8" Cross Oval	3/8"-CO	0-012
1/2" Cross Oval	1/2"-CO	0-016
9/16" Cross Oval	9/16"-CO	0-018
5/8" Cross Oval	5/8"-CO	0-020
3/4" Cross Oval	3/4"-CO	0-024
<b>EDGERS</b>		10-1069-
Cut Before Edger	2"-ED-R	0-100
Cut After Edger	2-5/16"-ED	0-104

## OPEN END BUTTONHOLE MODELS

DESCRIPTION	PRODUCT CODE NO.
CB-R-FE	10-001
CB-R-RE	10-002
CB-L-ME	10-004
CB-R-ME	10-008
CA-R-RE	10-011

DESCRIPTION	THROAT PLATES*	MAIN CAMS
CA-R-RE	10-4012-0-001	10-3064-0-045
CB-R-FE	10-4012-0-004	10-3064-0-063
CB-R-RE	10-4012-0-004	10-3064-0-055
CB-L-ME	10-4012-0-004	10-3064-0-061
CB-R-ME	10-4012-0-004	10-3064-1-059

\*NOTE: To obtain replacement throat plate, order part number 10-4012 plus the last four digits marked on the old throat plate.

This section contains parts special to the open end buttonhole machines, both Cut-Before and Cut-After models. All other parts are standard and should be found in the Adjustable Flybar Section of this manual.

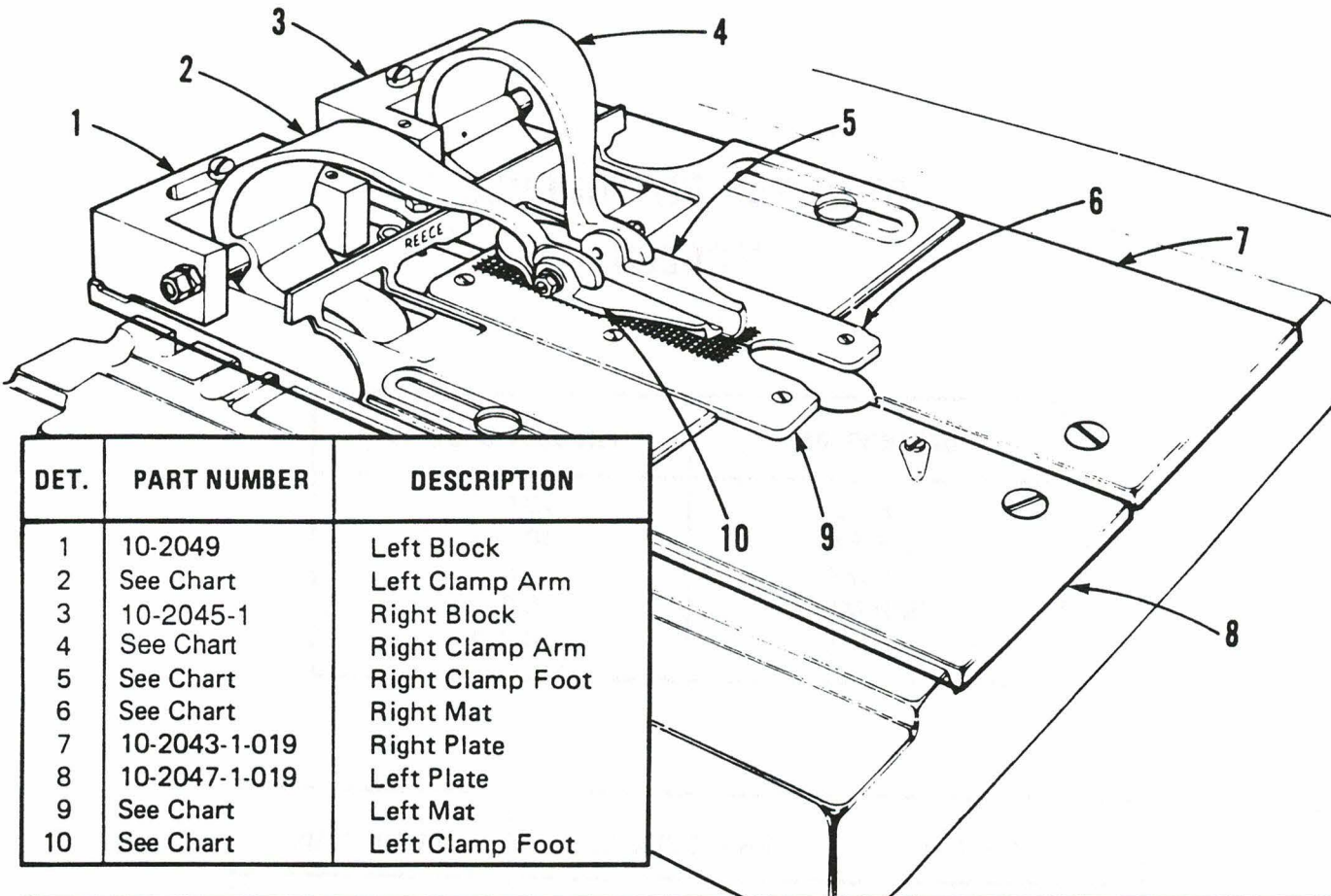

DET.	PART NUMBER	DESCRIPTION
1	10-2049	Left Block
2	See Chart	Left Clamp Arm
3	10-2045-1	Right Block
4	See Chart	Right Clamp Arm
5	See Chart	Right Clamp Foot
6	See Chart	Right Mat
7	10-2043-1-019	Right Plate
8	10-2047-1-019	Left Plate
9	See Chart	Left Mat
10	See Chart	Left Clamp Foot

STYLE NO.	DESCRIPTION	ARMS*		FEET		MATS	
		RIGHT (4) 10-2046-	LEFT (2) 10-2050-	RIGHT (5) 10-2046-	LEFT (10) 10-2050-	RIGHT (6) 10-2044-	LEFT (9) 10-2048-
10-001	CB-R-FE*	-2-701	-2-701	-1-751	-1-750	-0-002	-0-002
10-002	CB-R-RE*	-2-701	-2-701	-1-751	-1-750	-0-002	-0-002
10-004	CB-L-ME	-2-702	-2-702	-1-755	-1-754	-0-010	-0-010
10-007	CB-R-ME/LE-HH	-2-701	-1-712	-1-751	-1-756	-0-002	-0-002
10-008	CB-R-ME	-2-701	-2-701	-1-751	-1-750	-0-002	-0-002
10-011	CA-R-RE*	-2-701	-2-701	-1-751	-1-750	-0-001	-0-001
10-014	CA-R-ME-HH	-2-701	-1-712	-1-751	-1-756	-0-001	-0-001

\*Machines for which the following (shorter than standard) arms and feet are available

SHORT FEET	RIGHT (4) 10-2046-	LEFT (2) 10-2050-	RIGHT (5) 10-2046-	LEFT (10) 10-2050-	MATS
5/8"	10-2046- 2-704	10-2050- 2-713	10-2046- 1-752	10-2050- 1-751	STANDARD
3/4"	2-704		10-2046- 1-753	10-2050- 1-752	
Medium	2-704		10-2046- 1-754	10-2050- 1-753	

\*Machines for which the following (shorter than standard) arms and feet are available

SHORT FEET	RIGHT (4) 10-2046-	LEFT (2) 10-2050-	RIGHT (5) 10-2046-	LEFT (10) 10-2050-	MATS
3/4"	10-2046- 2-704	10-2050- 2-713	10-2046- 1-753	10-2050- 1-752	STANDARD
Medium	2-704	2-713	10-2046- 1-754	10-2050- 1-753	
Regular	2-704	2-713	10-2046- 1-751	10-2050- 1-750	

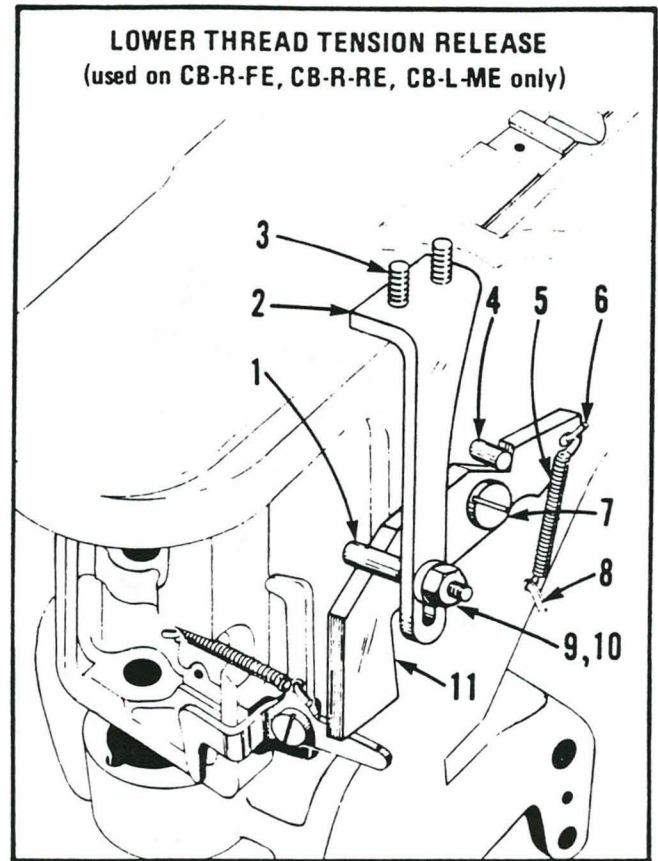
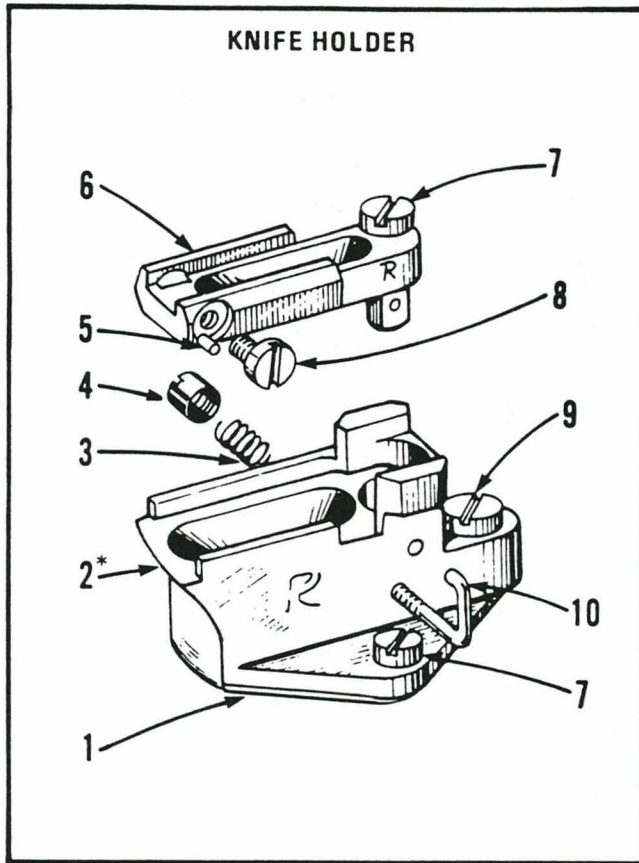

DET.	PART NUMBER	DESCRIPTION
1	10-3075-1-992	Shim (.016") Thickness
	10-3075-1-993	Shim (.005") Thickness
2	10-3070-1-050	Knife Holder Asm.
	10-3070-0-061	Knife Holder Asm. (CB-L-ME)
3	01-5070	Spring
4	01-3067	Nut
5	01-6034	Pin
6	10-3071-1	Pad
7	01-2039	Screw
8	01-2102	Screw
9	01-2038	Screw
10	10-3078	Pad Locking Pin

DET.	PART NUMBER	DESCRIPTION
1	10-2201-2	Stud
2	10-2200	Bracket
3	01-2059	Screw
4	01-6021	Pin
5	01-5039	Spring
6	01-6013	Anchor
7	01-1031	Screw
8	01-6011	Anchor
9	01-3011	Nut
10	01-4011	Washer
11	10-3207-0-200	Release Lever

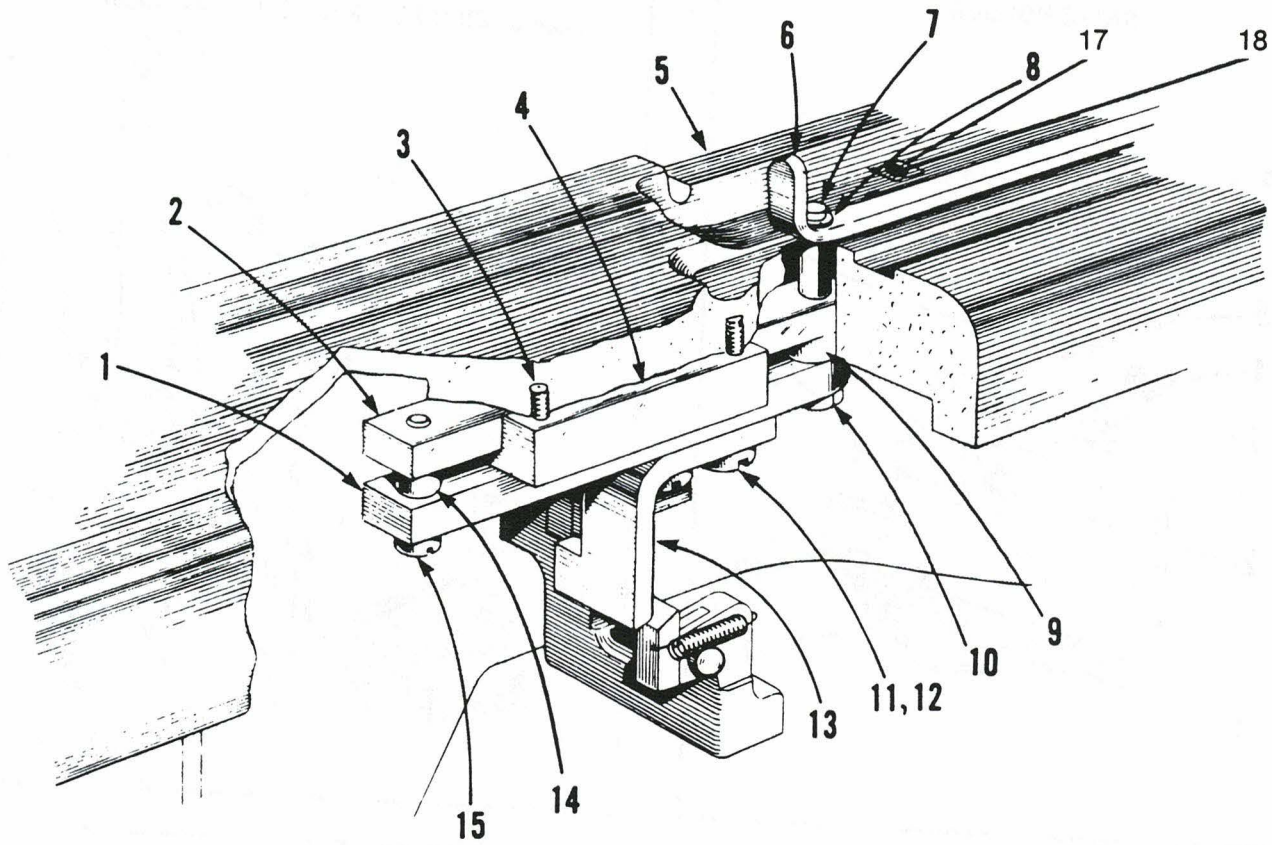

DET.	PART NUMBER	DESCRIPTION
1	10-2068	Support
2	10-2067	Link
3	01-2143	Screw
4	10-2065-1	Guide Plate
5	10-2001-2	Bedplate
6	10-2018-1	Length Gauge
7	01-6529	Stud
8	01-6368	Retaining Ring
9	01-7436	Spacer
10	01-3005	Nut
11	01-2041	Screw
12	01-4001	Washer
13	14-2069-0-050	Trip
14	01-7437	Bushing
15	01-2121	Screw
16	01-2068-1	Set Screw
17	10-2002	Plate
17	10-2002-0-601	Plate CARPE DGN
18	01-2042	Screw

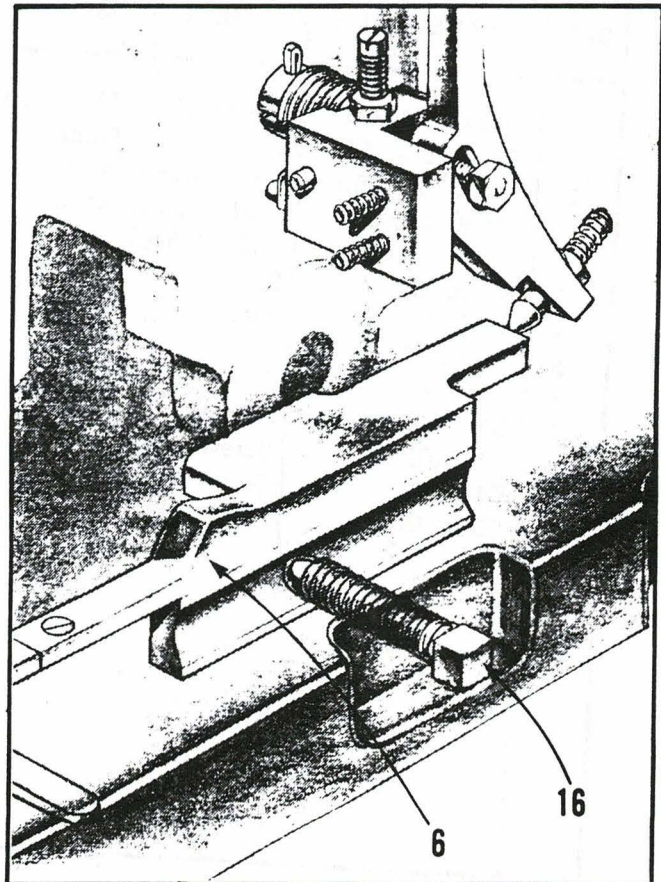

NO-EYE ATTACHMENT – COMBINATION LEVER

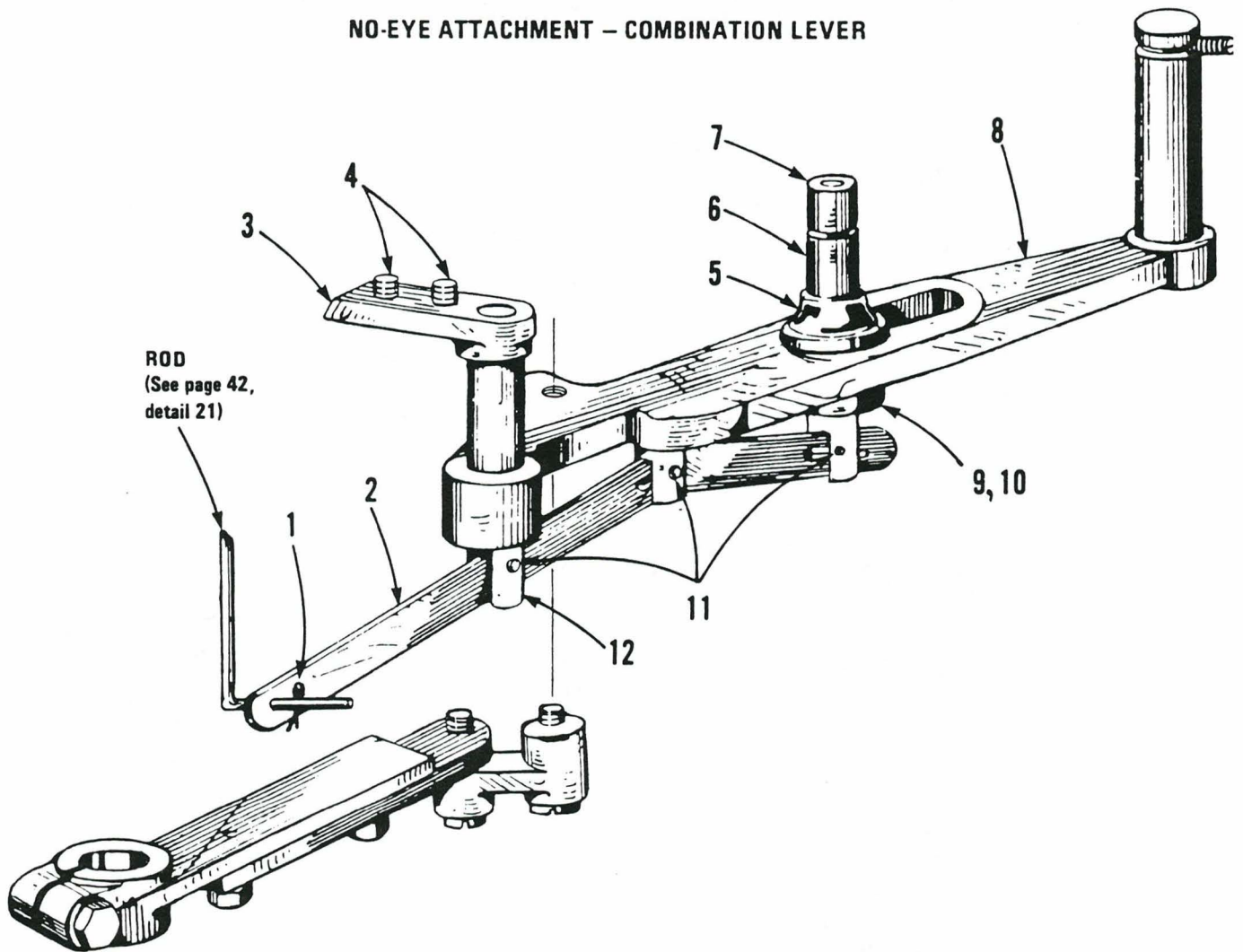

ROD  
(See page 42,  
detail 21)

NO-EYE ATTACHMENT  
REGULAR LEVER  
(CB-R-RE only)

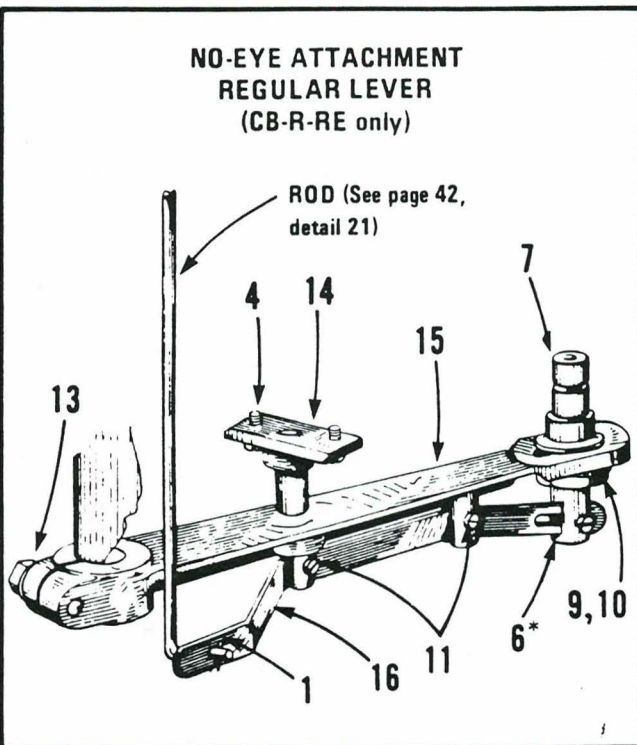

ROD (See page 42,  
detail 21)

DET.	PART NUMBER	DESCRIPTION
1	10-1053	Cotter Pin
2	10-3352	Lever
3	10-3350	Socket
4	01-2017	Screw
5	10-3020-0-005	Bushing
6	10-3328-0-050	Stud Assembly
7	01-7004	Roll
8	10-3351-1	Combination No-Eye Lever
9	01-3022	Nut
10	01-4020	Washer
11	01-2087	Screw
12	10-3327	Plunger
13	01-2016	Screw
14	10-3325	Lock
15	10-3019-0-001	Lower Lateral Lever
16	10-3326	Lever

LATERAL LEVER

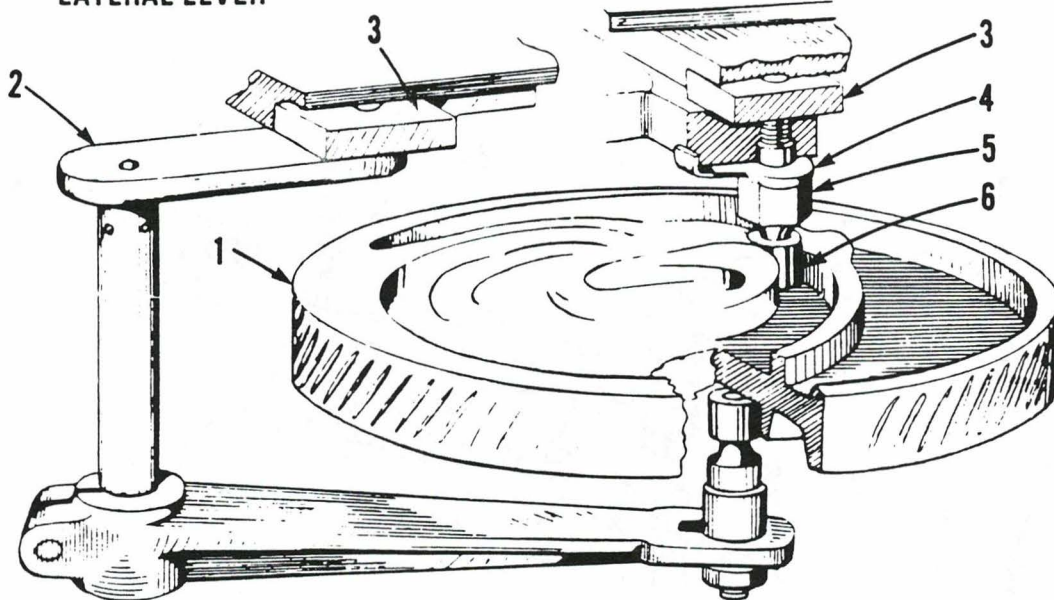

STRAIGHT AWAY GUIDE

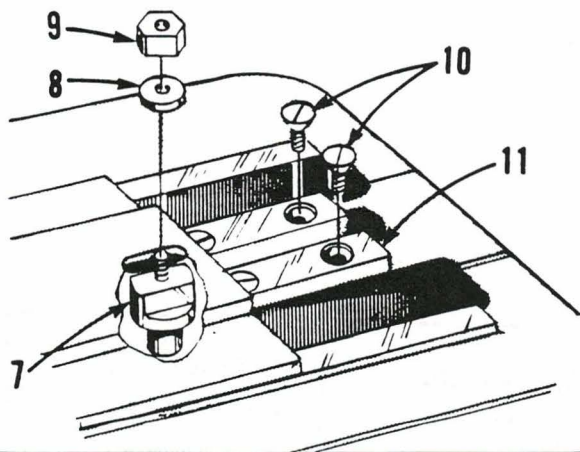

NO-EYE ATTACHMENT

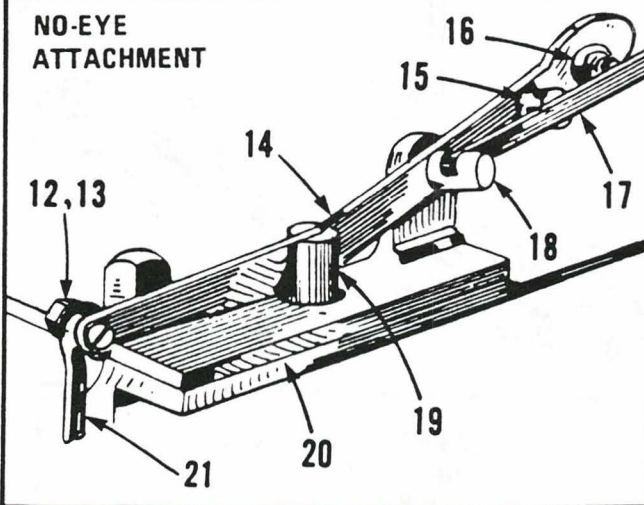

DET.	PART NUMBER	DESCRIPTION
1	See chart on page 37	Main Cam
2	10-3034	Upper Lateral Lever
3	10-3033-0-017	Block
4	10-2058	Locking Clip
5	10-2006-2	Stud
6	10-2007	Roll
7	10-1301	Stud & Roll
8	01-4024	Washer
9	01-3007	Nut
10	01-2050	Screw
11	10-2300-1-021	Guide Plate
12	10-1325	Screw

13	01-3005	Nut
14	10-1329	Lever
15	01-6013	Pin
16	01-5053	Spring
17	10-1328	Plunger Lever
18	10-1327	Plunger
19	01-2087	Screw
20	10-1330	Bracket
	10-1330-0-023	Bracket CB/CA-R-RE only
21	10-1326	Rod
	10-1326-0-023	Rod CB/CA-R-RE only
11	10-2300-0-058	Guide Plate CRB-5/8"
11	10-2300-0-078	Guide Plate CRB-7/8"
11	10-2300-0-100	Guide Plate CRB-1"

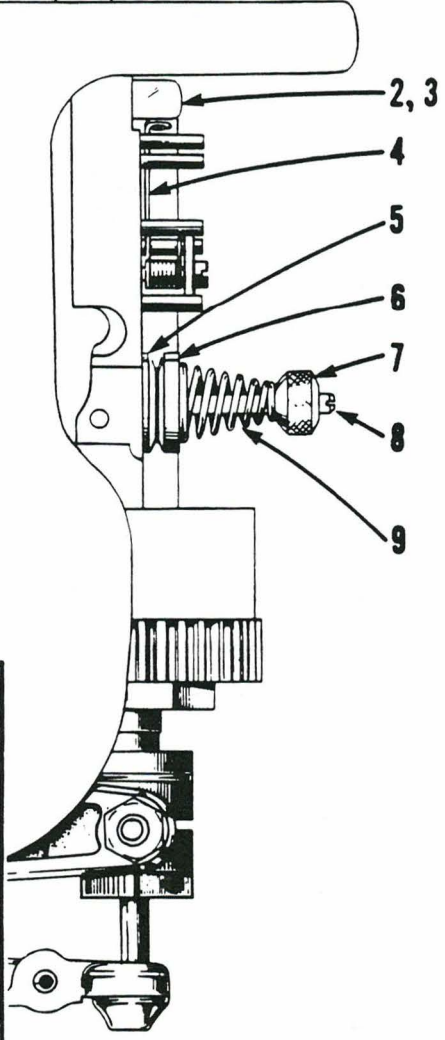
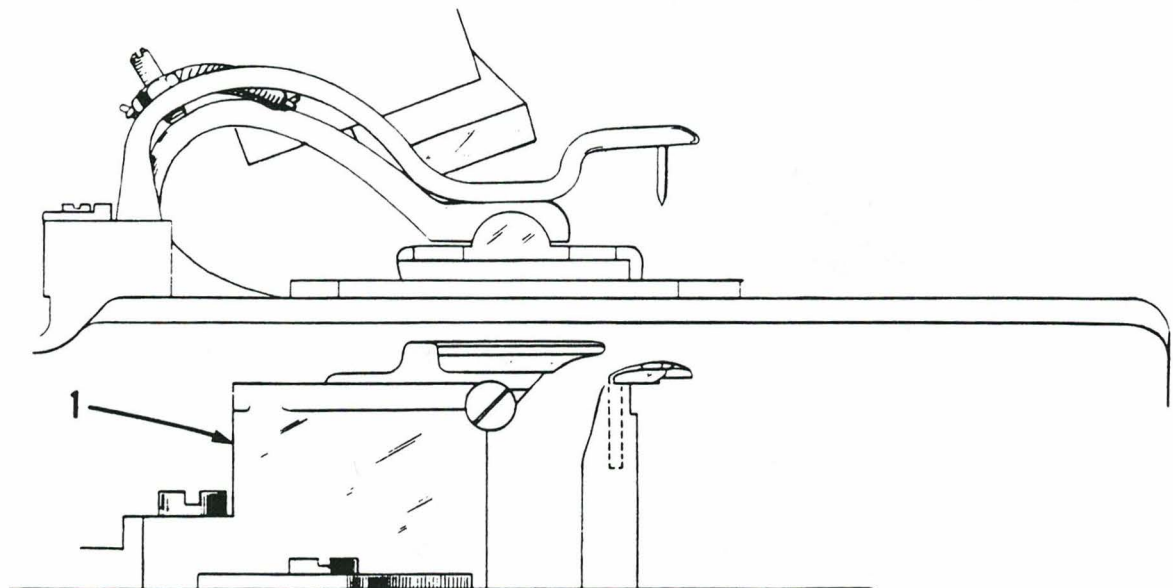

DET.	PART NUMBER	DESCRIPTION
1	10-3070-1-050	Knife Holder
2	10-4041	Guide
3	01-2356	Screw
4	01-5434	Check Spring
5	10-4032	Disc, Thin
6	10-4031	Disc, Heavy
7	10-4030	Nut
8	10-4029	Stud
9	01-5028	Spring

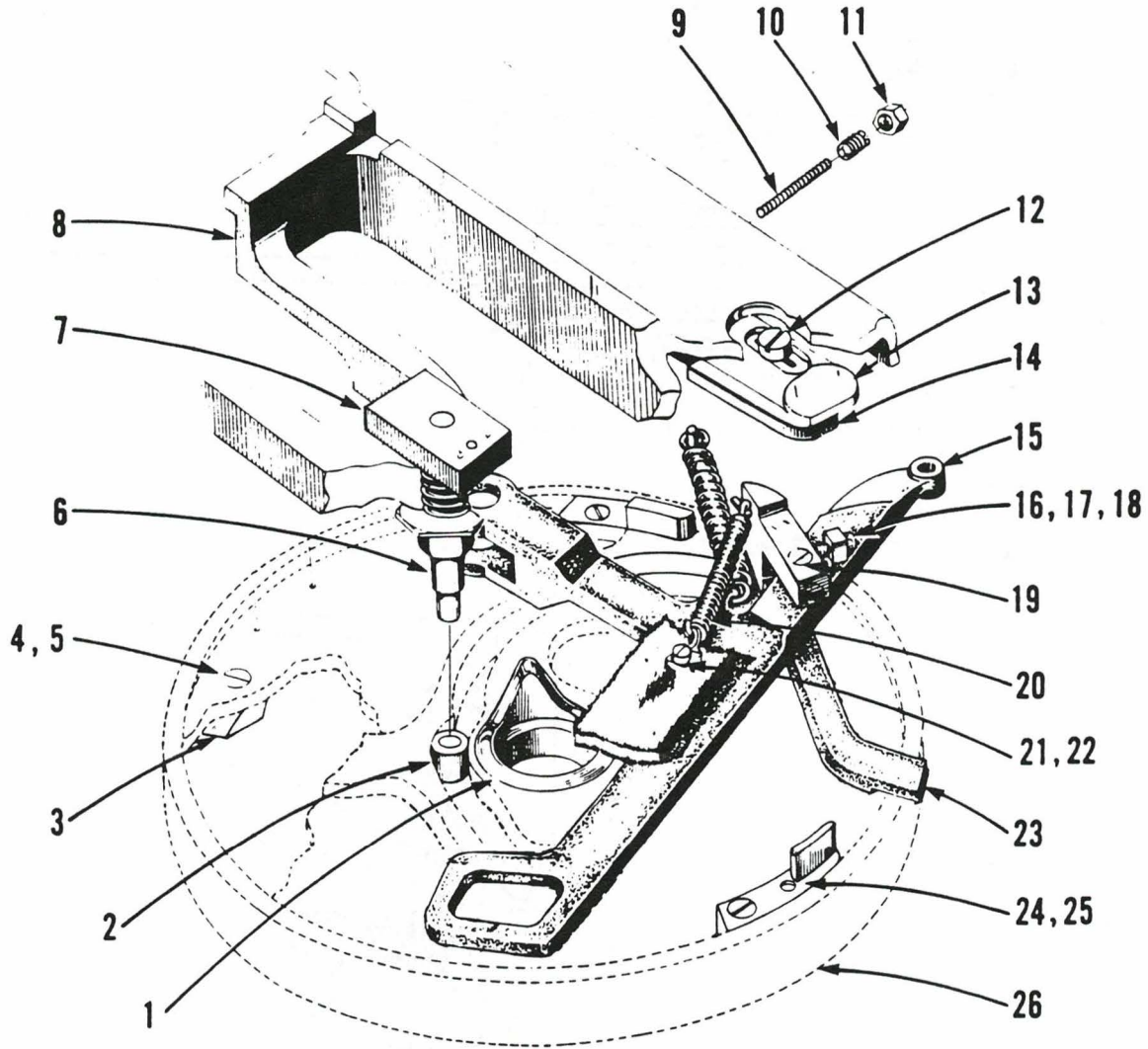

DET.	PART NUMBER	DESCRIPTION
1	10-3062-1	Cutting Cam
2	10-2007	Roll
3	10-3061-0-200	Clamping Wedge
4	01-2347	Screw
5	01-4061	Washer
6	10-2006-2	Stud
7	10-3033-0-017	Block
8	10-2001-2	Bedplate
9	01-5019	Spring
10	01-2567	Screw
11	01-3030	Nut
12	01-2027	Screw
13	10-2631	Switch Lever
14	10-2632	Block
15	10-3637	Shifting Lever

16	01-2045	Screw
17	01-3065	Nut
18	01-6167	Stud
19	01-1120	Screw
20	01-5126	Spring
21	01-2004	Screw
22	10-3639	Clip
23	10-3638	Stopping Lever
	10-3638-0-462	Stopping Lever
24	10-3636	Stopping Wedge
	10-3636-0-462	Stopping Wedge
25	01-2079	Screw
26	10-3064-1-059	Main Cam

## HANDHOLE MODELS

DESCRIPTION	PRODUCT CODE NO.
CB-R-ME CB-R-ME/LE-HH CA-R-ME-HH	10-008 10-007 10-014

This section contains parts special to Handhole models. All other parts are standard and should be found in the Adjustable Flybar section of this manual.

Used only on Cut After Models

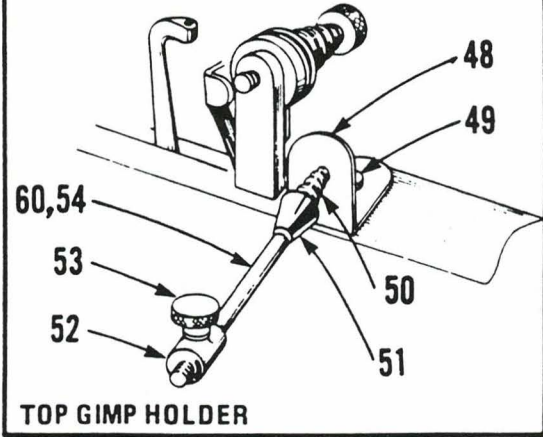

Note: These gimp attachment parts are also used on all machines using a double gimp attachment except cord trim.

For Adjustable Flybar & Open End Buttonhole Models.

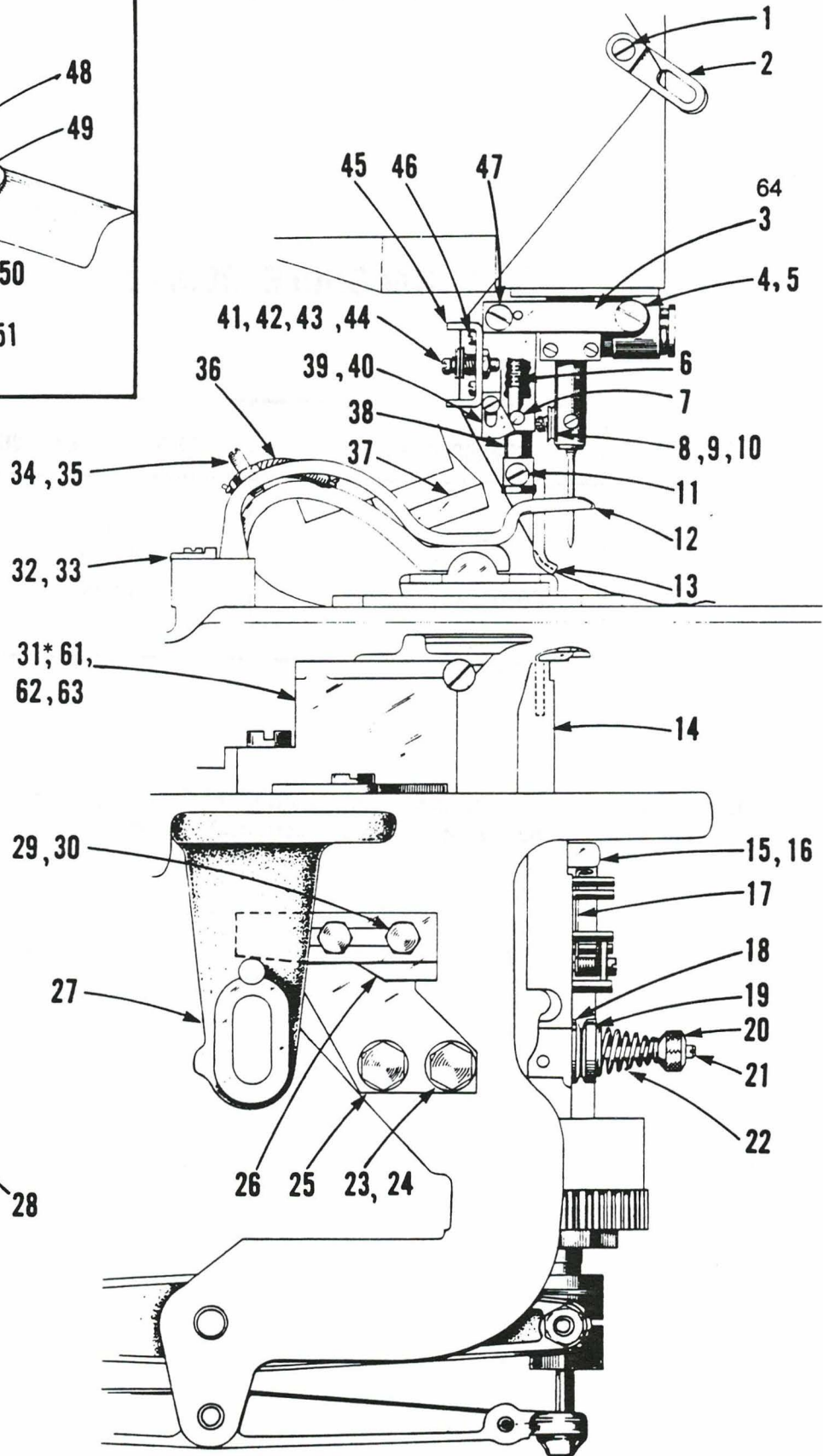

DET.	PART NUMBER	DESCRIPTION
1	01-2050	Screw
2	10-3607-1	Cord Guide
3	10-1404-1	Bracket
4	01-2024	Screw
5	01-7433	Bushing
6	01-5018	Spring
7	01-1427	Screw
8	10-1030-0-017	Screw
9	01-5167	Spring
10	10-1029-1	Disc
11	01-2073	Screw
12	10-2400-1	Lifting Finger
13	10-1405-1	Cord Guide
14	10-4001-1-200	Race
15	01-2356	Screw
16	10-4041	Guide
17	01-5434	Spring
18	10-4032	Thin Disc
19	10-4031	Heavy Disc
20	10-4030	Nut
21	10-4029	Stud
22	01-5028	Spring
23	01-2020	Screw
24	01-4024	Washer
25	10-3401	Bracket
26	10-3402	Cam Slide
27	10-2023-0-007	Bracket
28	01-2008	Screw
29	01-2074	Screw
30	01-4042	Washer
31	10-3070-2-060*	OE-HH Knife Holder
	10-3070-1-250	AF-HH Knife Holder

32	10-2002	Plate
33	01-2054	Screw
34	01-2320	Screw
35	01-3001	Nut
36	01-5052	Spring
37	See pgs. 35-36	Cutting Steel
38	10-1406-1	Lifter
39	10-1409	Stop
40	01-2081	Screw
41	20-0595-1	Screw
42	01-3065	Nut
43	01-4039	Disc
44	01-5004	Spring
45	10-1410	Cord Guide
46	01-2013	Screw
47	01-2045	Screw
48	10-1400-1	Bracket
49	01-2078	Screw
50	01-5051	Spring
51	10-5009	Thimble
52	10-1402	Thimble
53	10-1401	Clamp Screw
54	10-2057-1	Spindle
55	01-2167	Screw
56	10-1193-0-004	Needle Guard
57	01-1491	Standoff
58	01-2024	Screw
59	01-2193	Screw
60	01-3009	Nut
61	10-3078	Pad Locking Pin
62	01-3067	Nut
63	01-5070	Spring
64	10-1150	Plate

**Note:** When reordering knives use part number 10-3072, plus the last 4 digits stamped on the knife being replaced.

When reordering cutting steels use part number 10-1069, plus the last 4 digits stamped on the cutting steel being replaced.

\*10-3070-2-060 Assembly and 10-3070-0-250 are 027" lower than standard Knife Holders. On the Cut After and Adjustable Flybar Cut After, three (3) 10-3075-1-993 (.005").

MAIN CAM CHART		
PART NO.	STYLE	PROD. NO.
10-3064-1-059	CB-R-ME/LE-HH	007
10-3064-1-052	CA-R-ME-HH	014
10-3064-1-008	AF-CB-R-ME/LE-HH	026

For Adjustable Fly & Open End Buttonhole Models

Notes: These parts are also used on all machines using the double gimp attachment except cord trim models.

Top gimp attachment used only on Cut After Models.

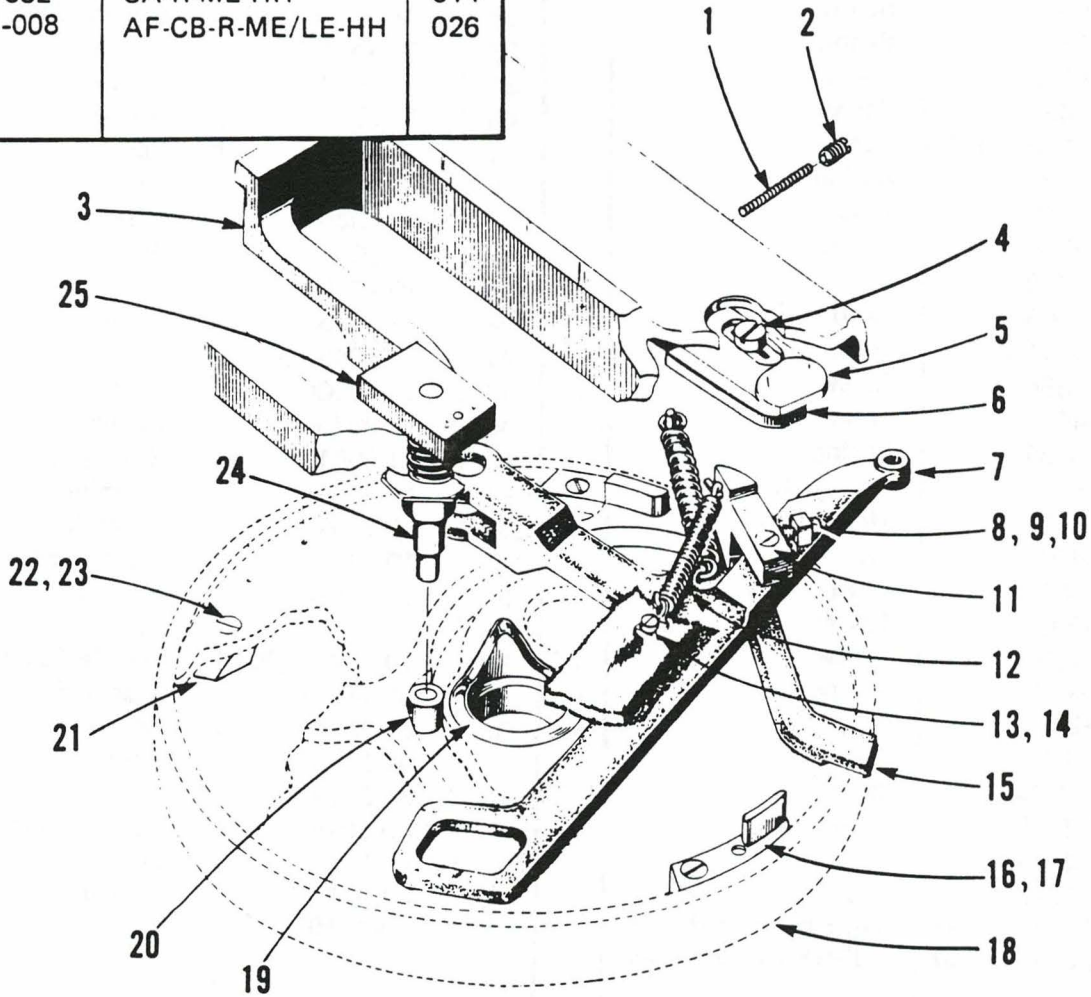

DET.	PART NUMBER	DESCRIPTION
1	01-5019	Spring
2	01-2567	Screw
3	10-2001-2	Bed Plate CB-R-ME/LE-HH CA-R-ME-HH
	10-2001-3-250	Bed Plate AF-CB-R-ME/LE-HH
4	01-2027	Screw
5	10-2631	Switch Lever
6	10-2632	Block
7	10-3637	Shifting Lever
8	01-2045	Screw
9	01-3065	Nut
10	01-6167	Stud

11	01-1120	Screw
12	01-5126	Spring
13	01-2004	Screw
14	10-3639	Clip
15	10-3638 10-3638-0-462	Stopping Lever CB Stopping Lever CA
16	10-3636 10-3636-0-462	Stopping Wedge CB Stopping Wedge CA
17	01-2079	Screw
18	See Chart	Main Cam
19	10-3062-1	Cutting Cam
20	10-2007	Roll
21	10-3061-0-200	Clamping Wedge
22	01-2347	Screw
23	01-4061	Washer
24	10-2006-2	Stud
25	10-3033-0-017	Block

## CUT-BEFORE/CUT-AFTER BUTTONHOLE MODELS

DESCRIPTION	PRODUCT CODE NO.	MAIN CAMS
CB/CA-R-RE	10-028	10-3064-0-045
AF/CB/CA-R-RE	10-030	14-3064-0-001

This section contains parts special to Cut-Before and Cut-After models. All other parts are standard and should be found in the Adjustable Flybar section of this manual.

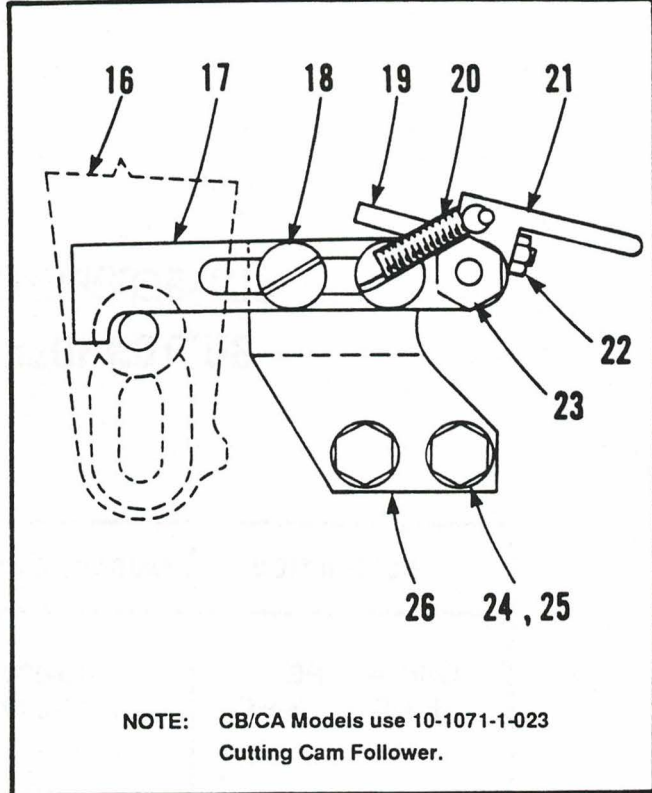
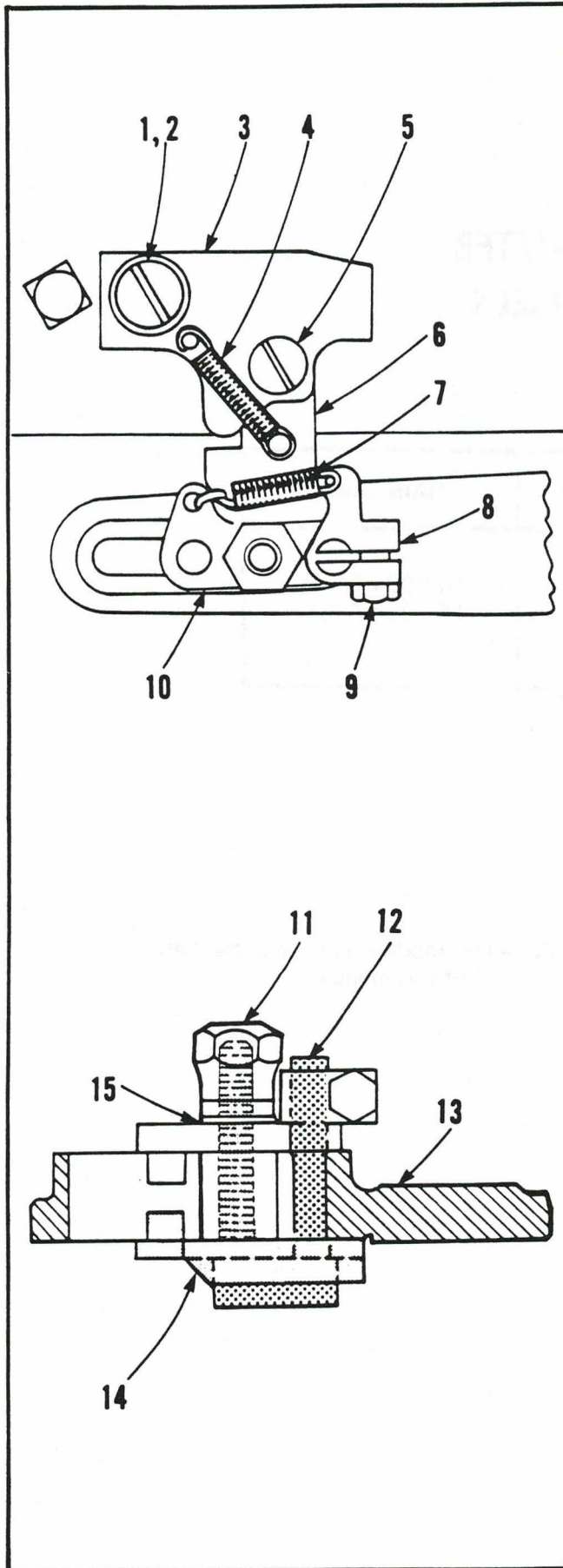

DET.	PART NUMBER	DESCRIPTION
1	01-2025	Screw
2	01-4522	Washer
3	10-1180	Block
4	01-5048	Spring
5	01-1100	Shoulder Screw
6	10-1181	Latch
7	01-5473	Spring
8	10-2073	Latch
9	01-2386	Screw
10	10-2072	Plate
11	10-2008	Adj. Nut
12	10-2071-1	Block
13	10-2012	Switch Lever
14	10-2070-1	Block
15	01-4063	Washer
16	10-2023-0-023	Bracket
17	10-3402-0-023	Slide Cam
18	01-1031	Shoulder Screw
19	01-2645	Screw
20	01-5429	Spring
21	10-3093	Latch
22	01-3001	Nut
23	01-1456	Stud
24	01-2020	Screw
25	01-4024	Washer
26	10-3401-0-023	Bracket

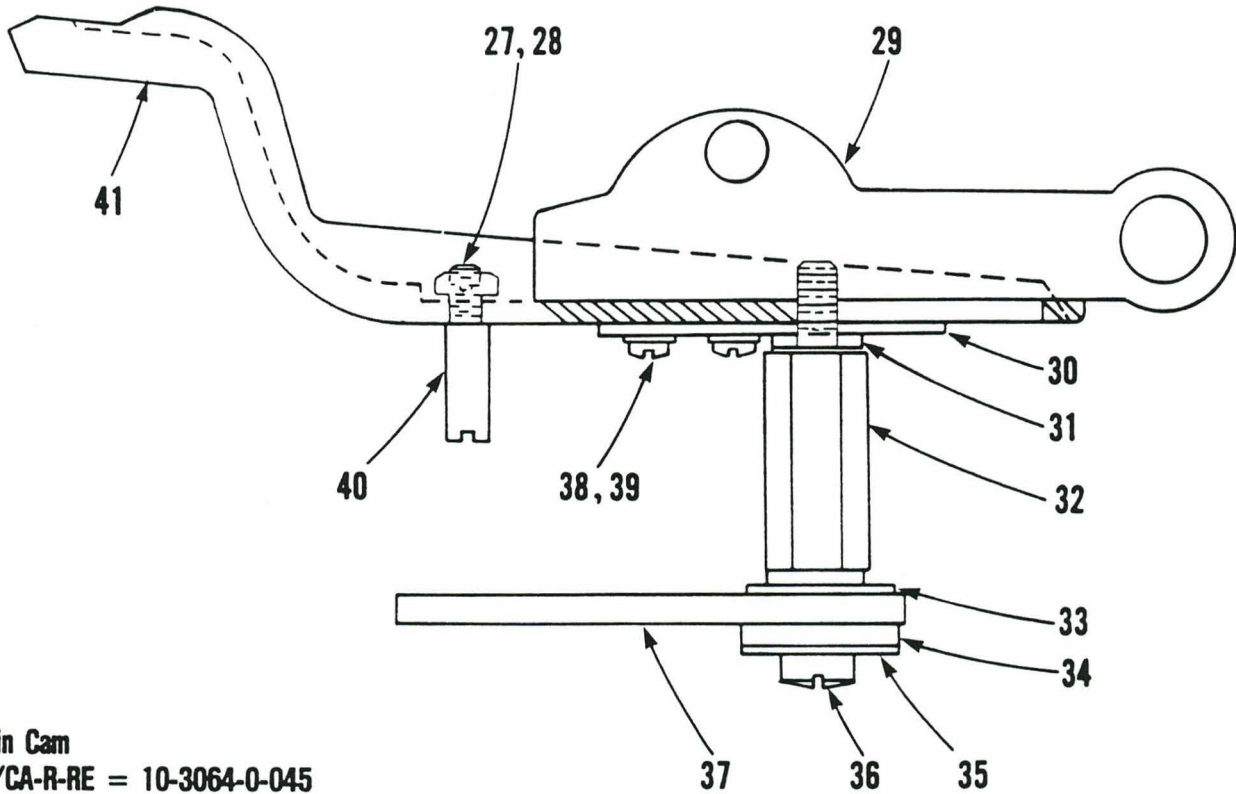

**Main Cam**

CB/CA-R-RE = 10-3064-0-045

AF-CB/CA-R-RE = 14-3064-0-001

27	01-4065	Washer
28	01-3005	Nut
29	10-3023	Clamping Lever
30	10-3094	Slide
31	01-4006	Washer
32	10-3092	Stud
33	01-6580	Retaining Ring
34	01-4501	Washer
35	01-4502	Washer
36	01-2115	Screw
37	04-0166	Handle
38	01-4029	Washer
39	01-2004	Screw
40	10-2014	Screw
41	10-3022-0-023	Arm
42	01-5475	Spring
43	10-2023-0-023	Toggle Bracket
44	10-2021-0-023	Toggle Lever
45	01-2344	Screw
46	10-2074	Bracket
47	01-1457	Screw
48	10-2075	Screw

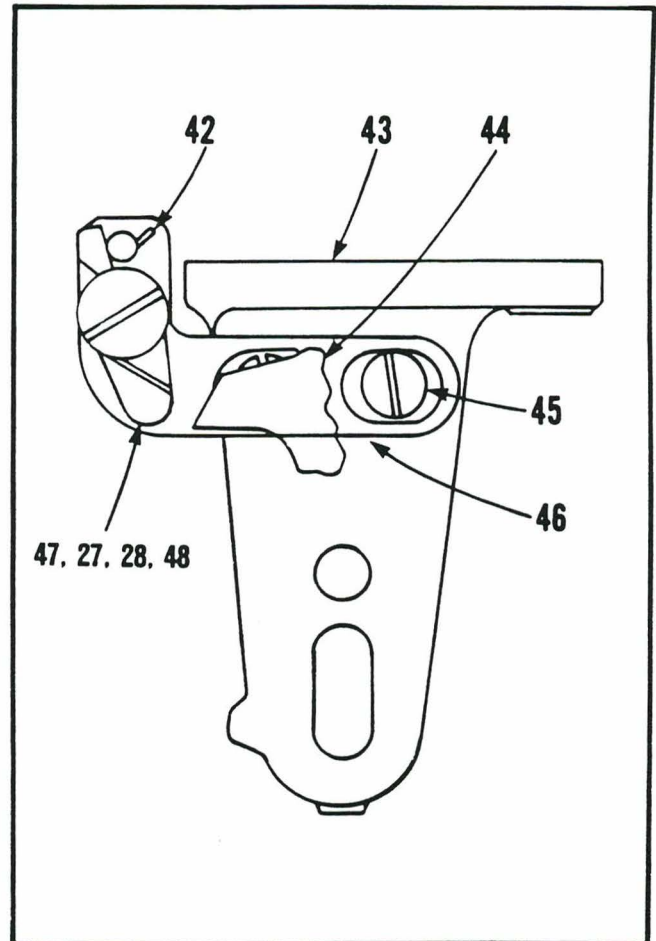



## CORD TRIM & CROSS BAR II MODELS

CORD TRIM MODELS	
DESCRIPTION	PRODUCT CODE NO.
CT-CA-9/16"-RE	10-032
CT-CA-5/8"-RE	10-033
CT-CA-5/8"-LE	10-034
CT-CA-3/4"-RE	10-035
CT-CA-7/8"-RE	10-036

This section contains parts special to Cord Trim & Cross Bar models. All other parts are standard and should be found in the Adjustable Flybar section of this manual.

CROSS BAR MODELS	
DESCRIPTION	PRODUCT CODE NO.
CRB-CA-5/8"-ME	10-041
CRB-CA-7/8"-ME	10-043
CRB-CA-1"-ME	10-044
CRB-CA-1 1/8"-ME	10-045
CRB-CA-1 1/4"-ME	10-046

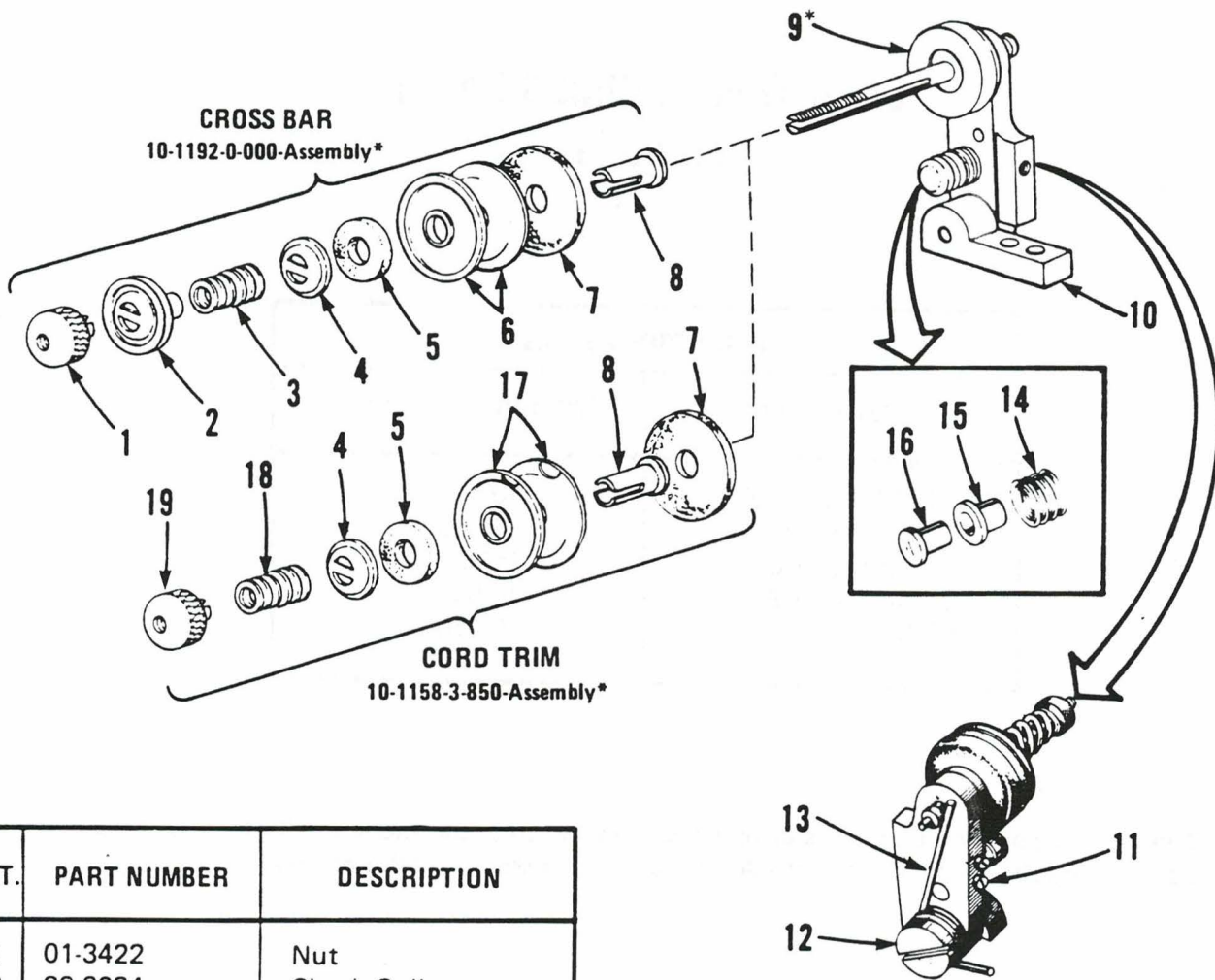

DET.	PART NUMBER	DESCRIPTION
1	01-3422	Nut
2	20-0684	Check Collar
3	01-5098	Spring
4	10-1003	Washer
5	10-1004	Felt Washer
6	20-0054	Tension Disc
7	10-1077	Felt Washer
8	10-1007	Bushing
9	10-1158-1-050	Tension Arm
10	10-1159	Tension Bracket
11	01-2001	Screw
12	01-1114	Screw
13	01-5163	Torsion Spring
14	01-5002	Spring
15	10-1009	Bushing
16	10-1008	Guide
17	10-1005	Split Tension
18	01-5001	Spring
19	10-4030	Nut
20	01-2039	Screw
21	10-1160	Cam
22	01-2362	Screw
24	01-6334	Rod

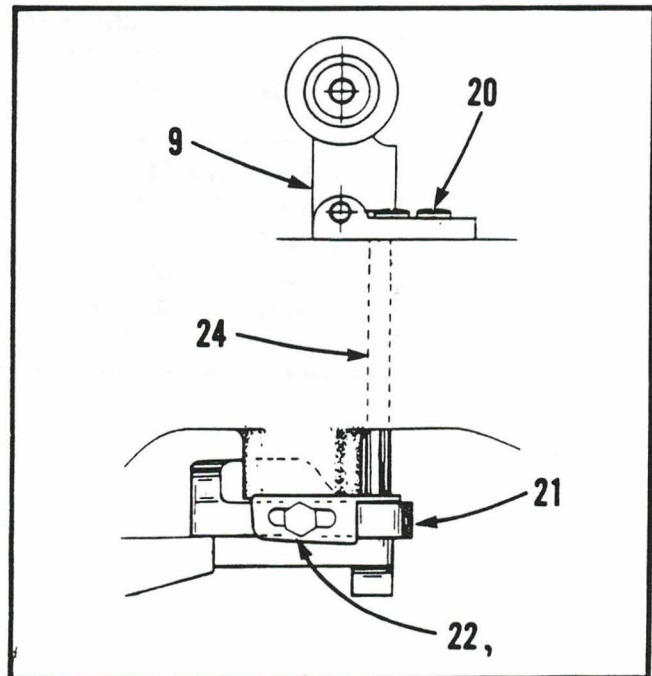

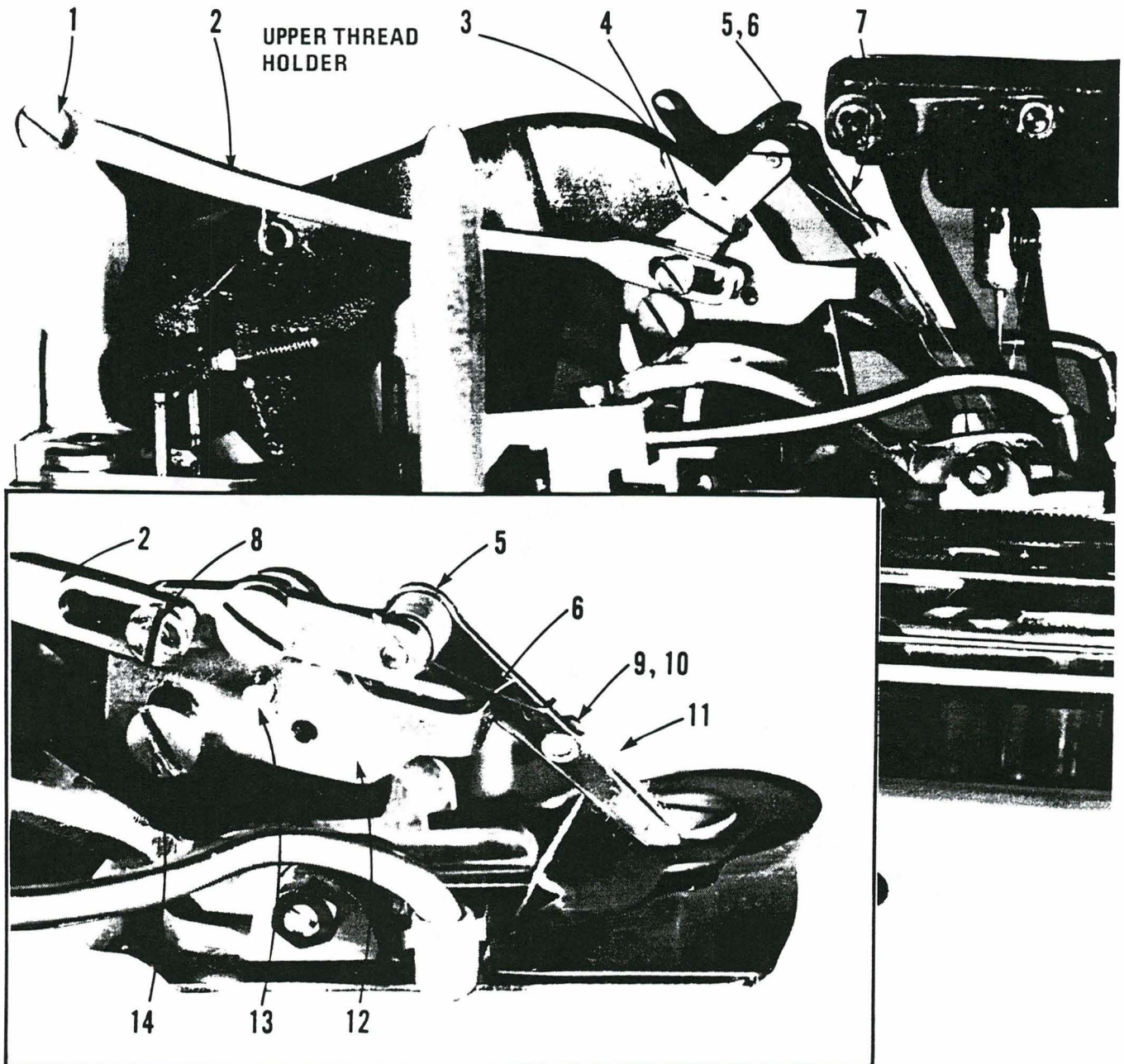

DET.	PART NUMBER	DESCRIPTION
1	10-1214	Screw
2	10-1205-1	Lever
3	10-1206	Link
4	10-1210-1	Pivot Screw
5	10-1208	Screw
6	01-5045	Spring
7	10-1207	Pickup
8	10-1209	Screw
9	01-2053	Screw
10	10-1211	Felt Retainer

11	10-1213	Felt
12	10-1204-2	Adj. Plate
13	01-6009	Pivot Pin
14	01-2006	Adj. Screw

CLAMP PLATE ASSEMBLY

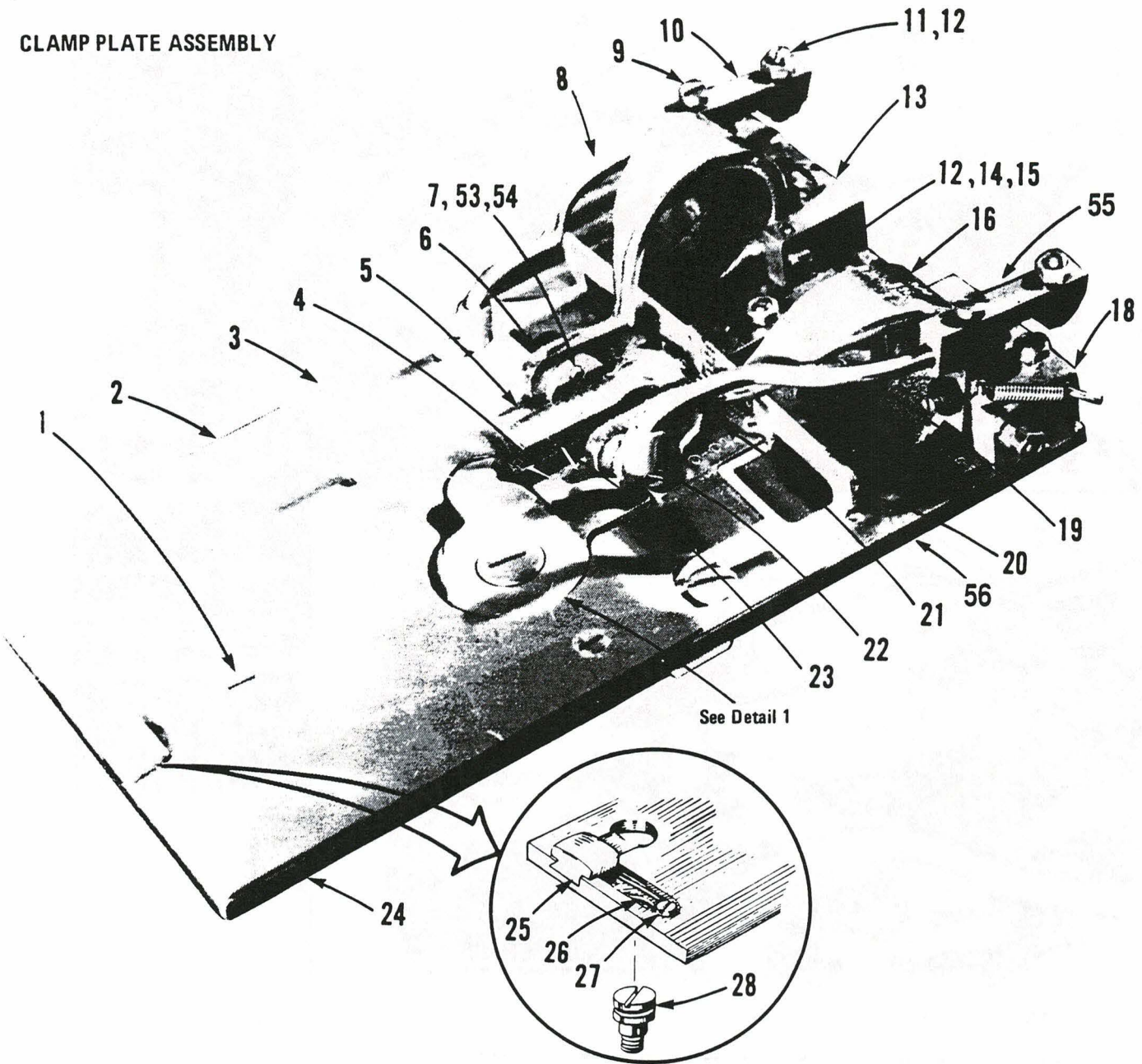

STYLE NO.	DESCRIPTION	CLAMP ARMS		CLAMP FEET		MATS	
		LEFT (6)	RIGHT (16)	LEFT (5)	RIGHT (4)	LEFT (23)	RIGHT (21)
10-032	CT-CA-9/16"-RE	10-2050-2-705	10-2046-2-706	10-2050-1-751	10-2046-1-752	10-2048-0-012	10-2044-1-012
10-033	CT-CA-5/8"-RE	10-2050-2-706	10-2046-2-707	10-2050-1-751	10-2046-1-752	10-2048-0-014	10-2044-1-014
10-034	CT-CA-5/8"-LE	10-2050-2-706	10-2046-2-707	10-2050-1-751	10-2046-1-752	10-2048-0-014	10-2044-1-014
10-035	CT-CA-3/4"-RE	10-2050-2-707	10-2046-2-708	10-2050-1-752	10-2046-1-753	10-2048-0-015	10-2044-1-015
10-036	CT-CA-7/8"-RE	10-2050-2-708	10-2046-2-709	10-2050-1-753	10-2046-1-753	10-2048-0-016	10-2044-1-016
10-041	CRB-CA-5/8"-ME	10-2050-2-704	10-2046-2-705	10-2050-1-751	10-2046-1-752	10-2048-0-011	10-2044-1-011
10-043	CRB-CA-7/8"-ME	10-2050-2-706	10-2046-2-707	10-2050-1-752	10-2046-1-753	10-2048-0-014	10-2044-1-014
10-044	CRB-CA-1"-ME	10-2050-2-708	10-2046-2-709	10-2050-1-752	10-2046-1-753	10-2048-0-016	10-2044-1-016
10-045	CRB-CA-1-1/8"-ME	10-2050-2-708	10-2046-2-709	10-2050-1-757	10-2046-1-756	10-2048-0-017	10-2044-1-017
10-046	CRB-CA-1 1/4"-ME	10-2050-2-708	10-2046-2-709	10-2050-1-758	10-2046-1-756	10-2048-0-002	10-2044-1-018

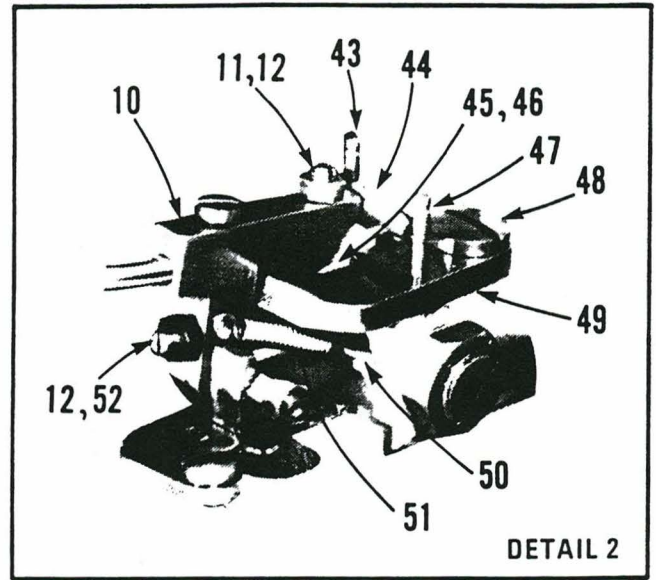
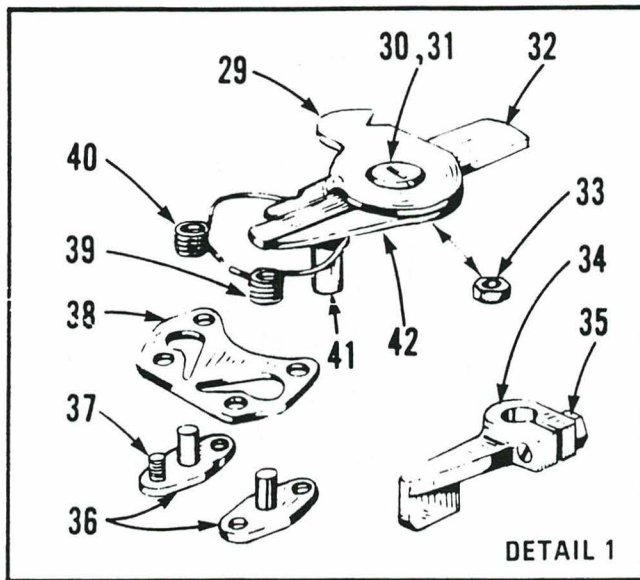

DET.	PART NUMBER	DESCRIPTION
1	01-2075	Screw
2	10-2047-1-019	Clamp Plate, L.H. (CT)
3	10-2060-1	Cloth Gauge, L.H.
4	See Chart	Foot, R.H.
5	See Chart	Foot, L.H.
6	See Chart	Arm, L.H.
7	01-1137	Pin
8	10-2212-1	Hold Down Finger, L.H.
9	01-2054	Screw
10	10-2211-0-001	Finger Holder
11	10-2214	Adj. Screw
12	01-3001	Nut
13	10-2049	Block, L.H.
14	10-2051-2	Stud
15	10-2052	Roll
16	See Chart	Arm, R.H.
18	10-2045-1	Block, R.H.
19	10-2212-0-001	Hold Down Finger, R.H.
20	10-2059-1-300	Cloth Gauge, R.H.
21	See Chart	Mat, R.H.
22	05-0360	Cap
23	See Chart	Mat, L.H.
24	10-2210	Cover Plate
25	10-2202	Latch
26	01-5034	Spring
27	01-2053	Screw
28	10-2035	Clamp Spreading Screw

29	03-5238 03-5239	Shear Set (CT) Shear Set (CRB)
30	10-2208-1	Pivot Screw
31	01-5062	Spring Washer
33	01-3021	Nut
34	10-2205	Lower Lever
35	01-2074	Screw
36	10-2218	Spring Mount
37	01-2104	Screw
38	10-2217	Spring Retainer
39	01-5064	Spring, R.H.
40	01-5065	Spring, L.H.
41	10-2204 10-2204-0-600	Actuator (CT) Actuator (CRB)
42	10-2203	Bearing (in plate)
43	01-6015	Anchor
44	01-5033	Spring
45	10-2215	Stop
46	10-1203	Stop Screw
47	01-6017	Anchor
48	01-1031	Shoulder Screw
49	10-1201 10-1201-0-001	Wedge, L.H. Wedge, R.H.
50	01-6002	Anchor
51	01-5037	Spring
52	01-3016	Nut
53	01-4038	Washer
54	01-2076	Adj. Screw
55	10-2211-0-000	Fingerholder
56	10-2043-1-019	Clamp Plate R.H. (CRB)

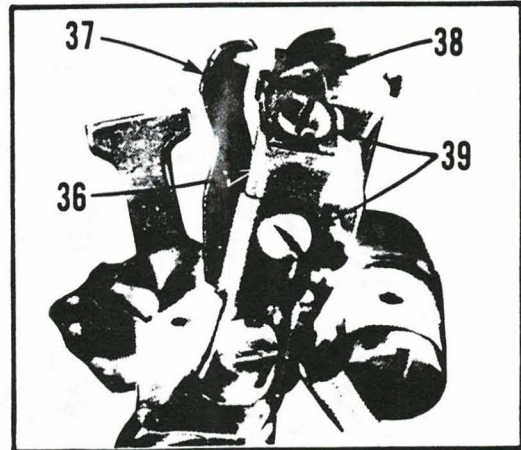
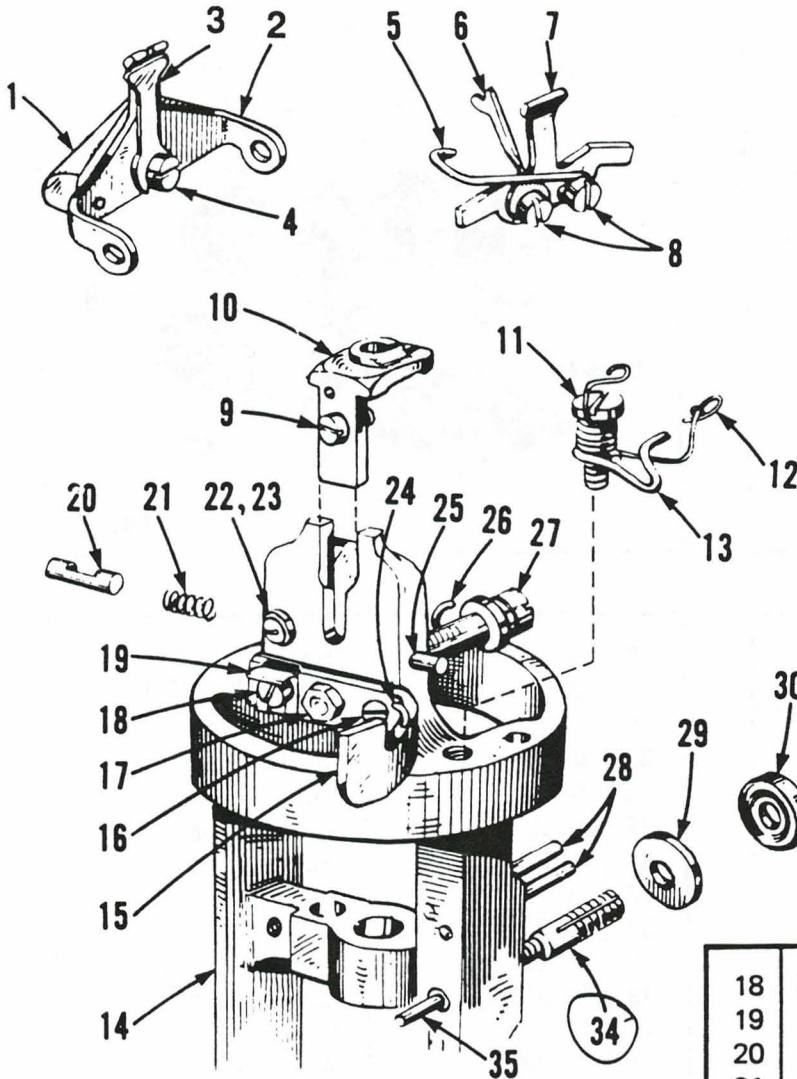

For additional Cross Bar Parts, refer to page 26, cut after detail.

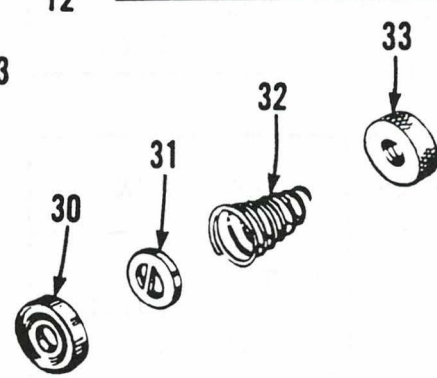

DET.	PART NUMBER	DESCRIPTION
1	10-4210	Cord Weight (CT)
2	10-4208-0-050	Cord Pull Back (ASM)
3	10-4209	Flat Spring (CT)
4	01-2136	Screw
5	10-4213	Check Wire (CT)
6	10-4212	Thread Guide (CT)
7	10-4010-2	Needle Guard
8	01-2073	Screw
9	01-2056	Screw
10	14-4012-1-013	Throat Plate
11	10-4215	Shoulder Screw (CT)
12	01-5043	Spring (CT)
13	10-4211	Stop Wire (CT)
14	10-4001-1-301	Race (CT)
15	10-4200	Trimmer Cam
16	01-2075	Screw
17	01-3021	Nut

18	01-2008	Screw
19	10-4220	Adj. Stop (CT)
20	10-4217	Plunger
21	01-5044	Spring
22	01-2318	Screw
23	01-4015	Washer
24	01-6001	Anchor
25	01-6010	Pin
26	01-6002	Anchor
27	14-4201	Stud
28	01-6018	Pin
29	10-4032	Disc
30	10-4031	Cup Disc
31	10-4221	Release Washer (CT)
32	01-5059	Spring (CT)
33	10-4030-0-300	Nut (CT)
34	10-4218	Stud (CT)
35	10-4219	Release Rod (CT)
36	10-1198-1	Knife Holder
37	10-1703-3	Thread Retainer
38	14-1197-0	Knife Trimmer
39	01-2667	Screw

**THROAT PLATE SECTION/CORD PULLBACK  
CROSS BAR**

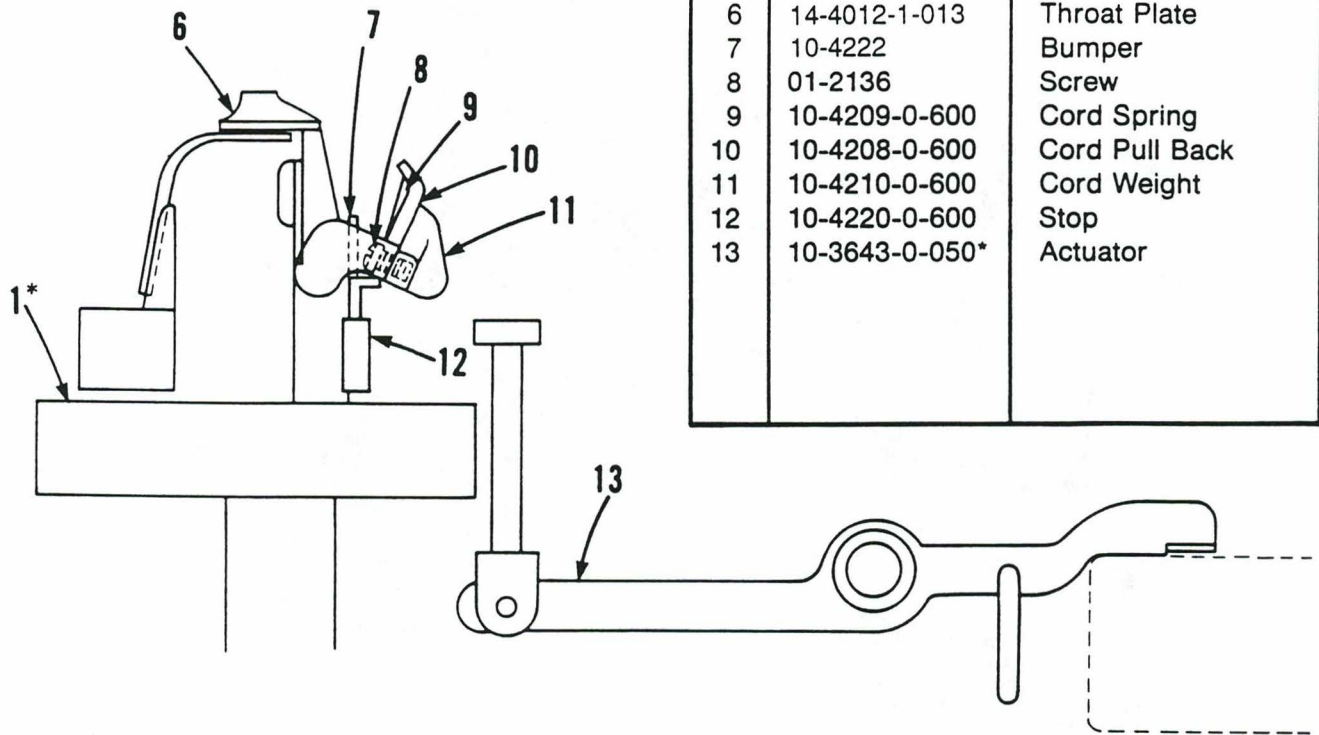

DET.	PART NUMBER	DESCRIPTION
1	10-4001-1-001	Race
6	14-4012-1-013	Throat Plate
7	10-4222	Bumper
8	01-2136	Screw
9	10-4209-0-600	Cord Spring
10	10-4208-0-600	Cord Pull Back
11	10-4210-0-600	Cord Weight
12	10-4220-0-600	Stop
13	10-3643-0-050*	Actuator

**STITCH STOPPING  
CROSS BAR**

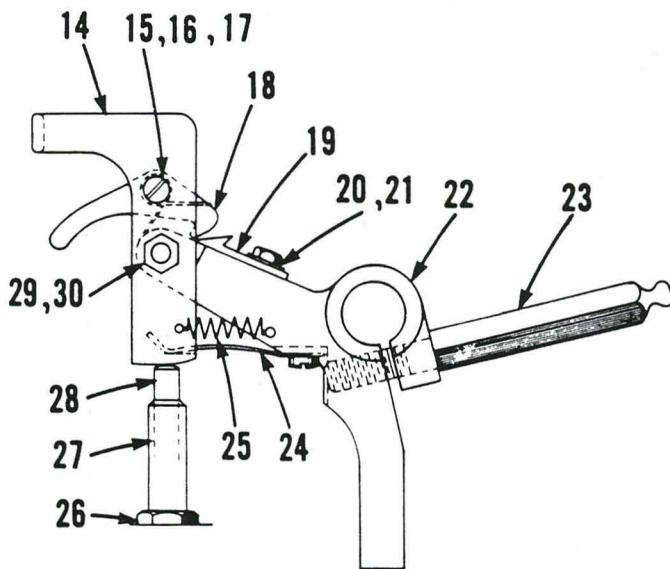

14	10-1179-1	Latch
15	01-3491	Nut
16	01-5522	Spring
17	10-2051-2	Shoulder Screw
18	10-1186	Latch
19	10-1165-1	Latch
20	01-2124	Screw
21	01-4013	Washer
22	10-1113-1-350	Three Fork Lever
23	01-1445	Clamp Screw
24	01-5524	Spring
25	01-5460	Spring
26	01-3026	Nut
27	10-3426	Stitch Rod Bushing
28	10-3502	Stitch Rod
29	01-1446	Pivot Screw
30	01-3020	Nut

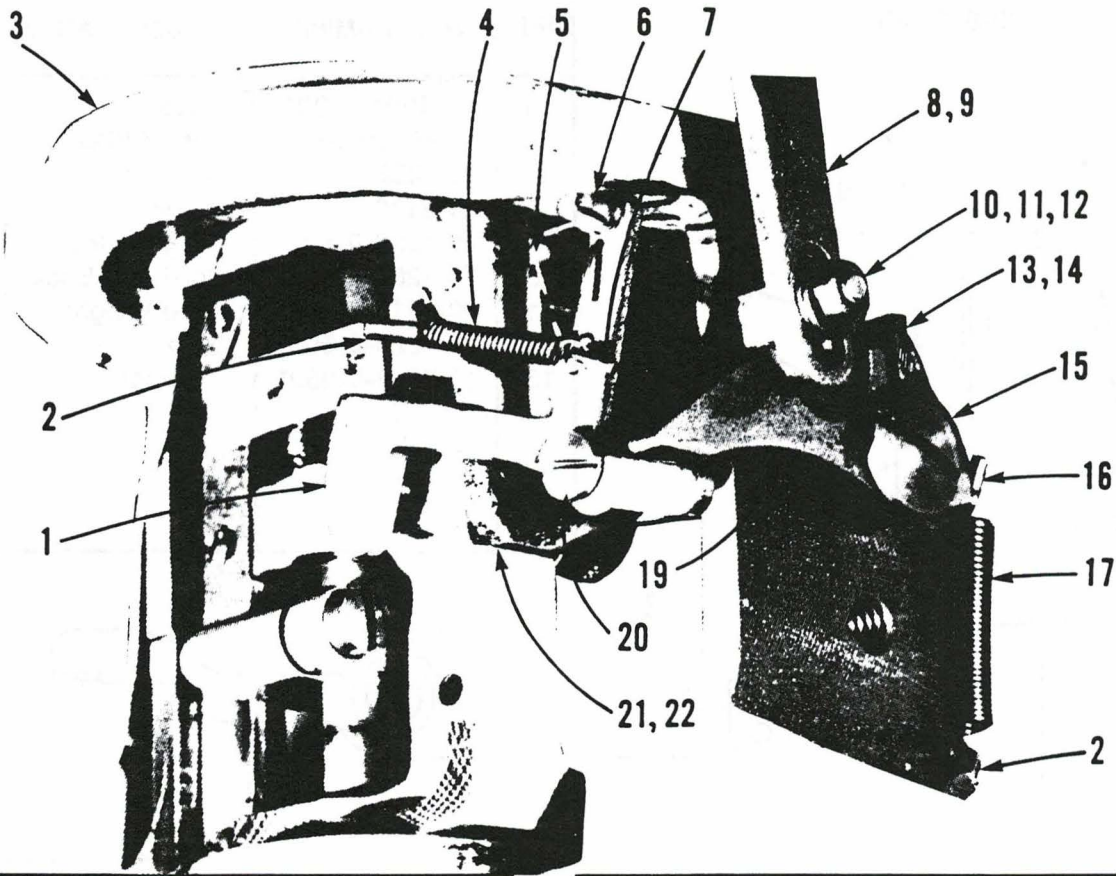

DET.	PART NUMBER	DESCRIPTION
1	10-4205 10-4205-0-002	Draw Off Lever (CT) Draw Off Lever (CRB)
2	01-6013	Stop Pin
3	See Pages 58-59	Race
4	01-5042	Spring
5	10-4206	Loop Puller
6	01-2081	Screw
7	01-6002	Anchor
8	01-2059	Screw
9	10-2200	Bracket
10	10-2201-2	Stud
11	01-3001	Nut
12	01-4042	Washer
13	01-2004	Screw
14	10-3209	Adj. Stop
15	10-3208	Shoulder Screw
16	01-6011	Anchor
17	01-5039	Spring
19	10-3207	Side Lever
20	01-1072	Screw
21	10-4207	Bracket
22	01-2075	Screw
23	01-2038	Screw

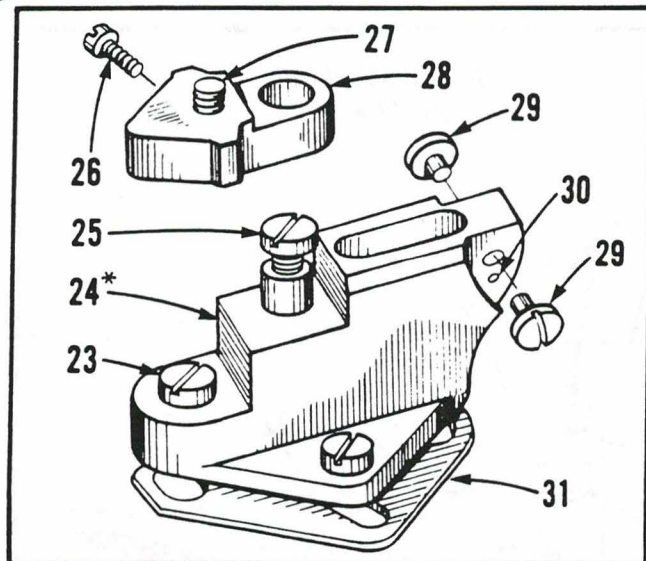

24	10-3058-1-300	Knife Holder
25	01-2039	Screw
26	01-2001	Screw
27	14-3002	Stud
28	10-3067-2-253	Spreading Block
29	01-2102	Screw
30	01-6034	Pin
31	10-3075-1-992	Shim, .016"
	10-3075-1-993	Shim, .005"

CORD TRIM & CROSS BAR II

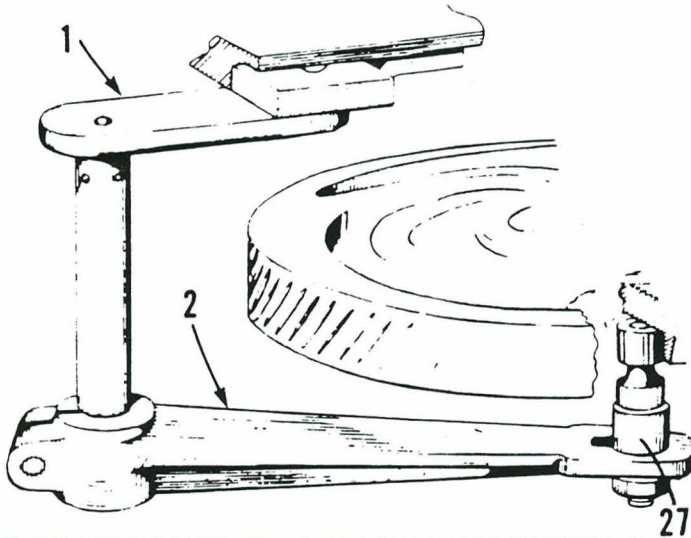

CORD TRIM – MAIN CAM  
WEDGES & FILLER PIECES

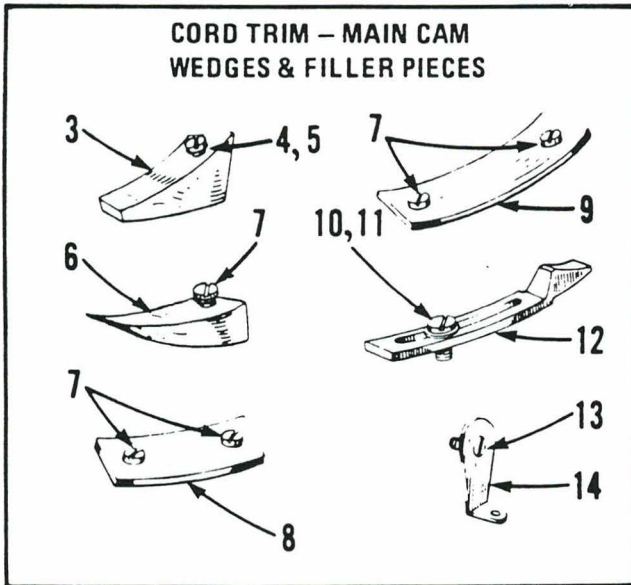

UPPER THREAD TRIMMER

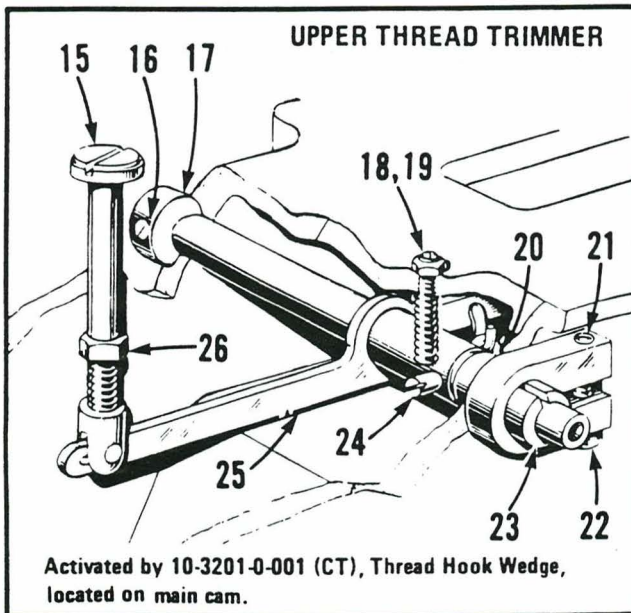

MAIN CAMS – CORD TRIMS

PROD. NO.	DESCRIPTION	PART NUMBER
10-032	CT-CA-9/16"-RE	10-3064-1-035
10-033	CT-CA-5/8"-RE	10-3064-2-036
10-034	CT-CA-5/8"-LE	10-3064-1-033
10-035	CT-CA-3/4"-RE	10-3064-1-037
10-036	CT-CA-7/8"-RE	10-3064-1-038

DET.	PART NUMBER	DESCRIPTION
1	10-3034-0-300	Upper Lateral Lever (CT & 1/2" CRB)
	10-3034	Upper Lateral Lever (CRB except 1/2")
2	10-3019-0-300	Lower Lateral Lever (CT)
	10-3019-1-006	Lower Lateral Lever (CRB)
3	10-3061-0-300	Clamping Wedge (all CT & 5/8" & 7/8" CRB)
	10-3061-1	Clamping Wedge (1", 1-1/8" & 1-1/4" CRB)
4	01-2347	Screw
5	01-4061	Washer
6	10-3200	Unclamping Wedge
7	01-2054	Screw
8	10-3216-0-600	Short Filler Piece (5/8" & 7/8" CRB)
9	10-3216-0-011	Long Filler Piece (CT)
10	01-2059	Screw
11	01-4013	Washer
12	10-3201-0-001	Trimmer Wedge
13	01-2050	Screw
14	10-3217	Cord Guide
15	10-3206	Actuator
16	01-2194	Screw
17	01-7435-1	Collar
18	01-2077	Screw
19	01-3005	Nut
20	01-5038	Spring
21	10-3090	Clamp
22	01-2024	Screw
23	01-7438	Split Bushing
24	10-3203	Stop
25	10-3202-0-050	Lever Assembly (CT)
26	01-3016	Nut
27	10-3020-0-007	Stut (Crossbar)
12	10-3201-1-200	Trimmer Wedge (XLE)

CROSS BAR MAIN CAM

MAIN CAM – CROSS BAR		
PROD. NO.	DESCRIPTION	PART NUMBER
10-041	CRB-CA-5/8"-ME	10-3064-0-085
10-043	CRB-CA-7/8"-ME	10-3064-0-086
10-044	CRB-CA-1"-ME	10.3064-1-080
10-045	CRB-CA-1 1/8" ME	10-3064-1-083
10-046	CRB-CA-1 1/4"-ME	10-3064-1-084

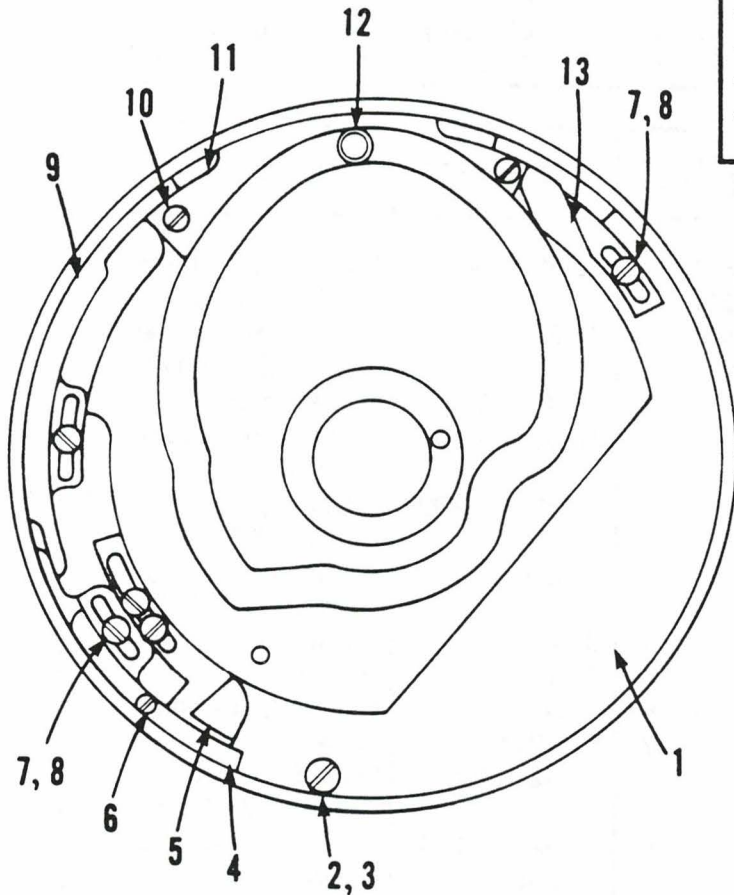

TOP VIEW

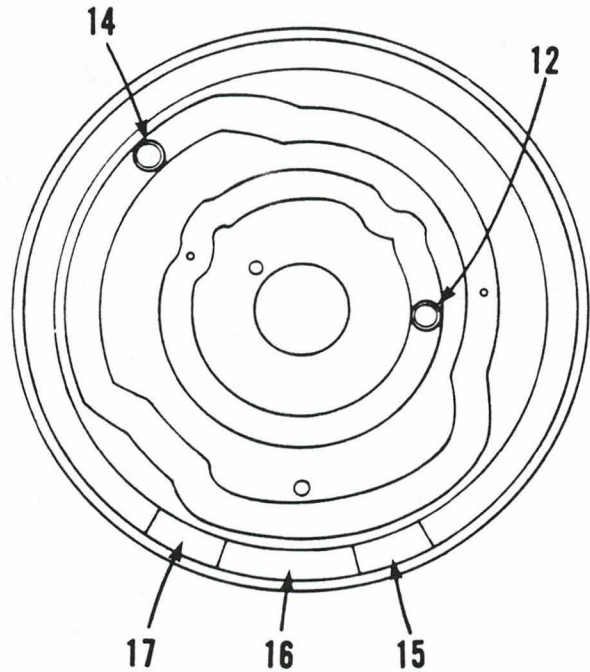

BOTTOM VIEW

DET.	PART NUMBER	DESCRIPTION
1	See Chart	Main Cam
2	01-2500	Screw
3	01-4061	Washer
4	10-3507-0-001	Stitch Ring (1")
	10-3507-0-600	Stitch Ring (1-1/8", 1-1/4")
	10-3514-0-001	Stitch Ring (1-1/8", 1-1/4")
	10-1225	Stitch Ring (5/8", 7/8")
5	10-3431-1-600	Trim Wedge
6	01-2054	Screw
7	01-2079	Screw
8	01-4012	Washer

9	10-3636-1-600	Stitch Ring (5/8")
9	10-3638-1-600	Ring (7/8")
10	01-2979	Screw
11	10-3432	Plate (1-1/8")
	10-3432-0-001	Plate (1-1/4")
12	01-7023	Roll
13	10-1223	Wedge (1-1/4")
14	10-3018-0-350	Roll
15	10-3200	Unclamping Wedge
16	10-3216-0-600	Filler Piece (5/8", 7/8")
17	10-3061-0-300	Clamping Wedge (5/8", 7/8")
	10-3061-1	Clamping Wedge (1", 1-1/8", 1-1/4")

## ROUND EYELET MODELS

DESCRIPTION	PRODUCT CODE NO.
RdE-S RdE-M	10-052 10-053

This section contains parts special to Round Eyelet models. All other parts are standard and should be found in the Adjustable Flybar section of this manual.

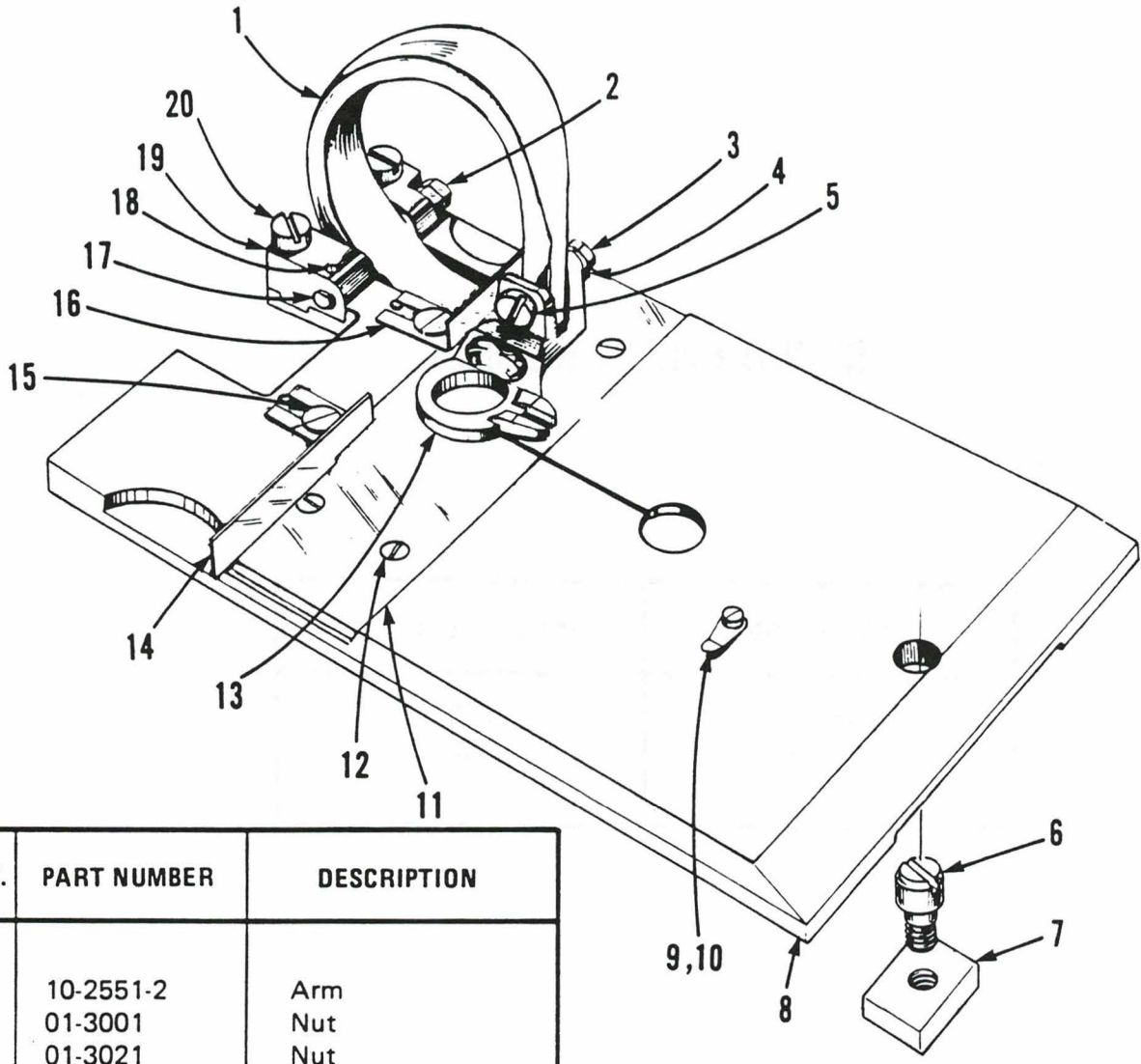

DET.	PART NUMBER	DESCRIPTION
1	10-2551-2	Arm
2	01-3001	Nut
3	01-3021	Nut
4	01-3066	Nut
5	01-1461	Screw
6	01-2587	Screw
7	10-2626	Nut Block
8	10-2553-1	Clamp Plate
9	10-2054	Clip
10	01-2053	Screw
11	See Page 65	Mat
12	01-2075	Screw
13	See Page 65	Foot
14	10-2566	Left Gauge
15	01-2111	Screw
16	10-2567	Right Gauge
17	10-2053	Pivot Stud
18	01-2052	Screw
19	10-2555-1	Block
20	01-2051	Screw

The mat and foot combinations shown in the chart below are for use with a standard 3/32" stitch bite. A larger or smaller stitch bite may require that the next size larger or smaller mat and foot combination be used.

The mat opening may be enlarged by careful filing to accommodate *extra* thick material.

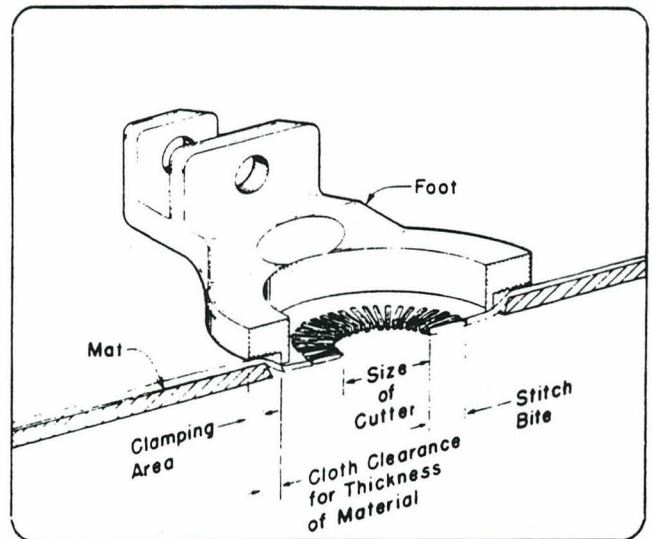

COMBINATIONS FOR THIN OR THICK MATERIAL WITH STANDARD 3/32" STITCH BITE						
MODEL	CUTTER	CUTTING STEEL	FOR THIN MATERIAL		FOR THICK MATERIAL	
			FOOT	MAT	FOOT	MAT
S	10-3553-0-002 (1/16")	10-1550-0-002 (1/16")	10-2552-2-004	10-2559-1-004	10-2552-2-104	10-2559-1-104
	10-3553-0-003 (3/32")					
M	10-3553-0-004 (1/8")	10-1550-0-004 (1/8")	10-2552-2-004	10-2559-2-104		
	10-3553-0-005 (5/32")	10-1550-0-006 (3/16")	10-2552-2-006	10-2559-1-006	10-2552-2-106	10-2559-1-106
	10-3553-0-006 (3/16")					
	10-3553-0-008 (1/4")	10-1550-0-008 (1/4")	10-2552-2-010	10-2559-1-010	10-2552-2-010	10-2559-1-014
	10-3553-0-010 (5/16")	10-1550-0-010 (5/16")				
	10-3553-0-011 (11/32")	10-1550-0-011 (11/32")	10-2552-2-012	10-2559-1-012	10-2552-2-012	10-2559-1-016

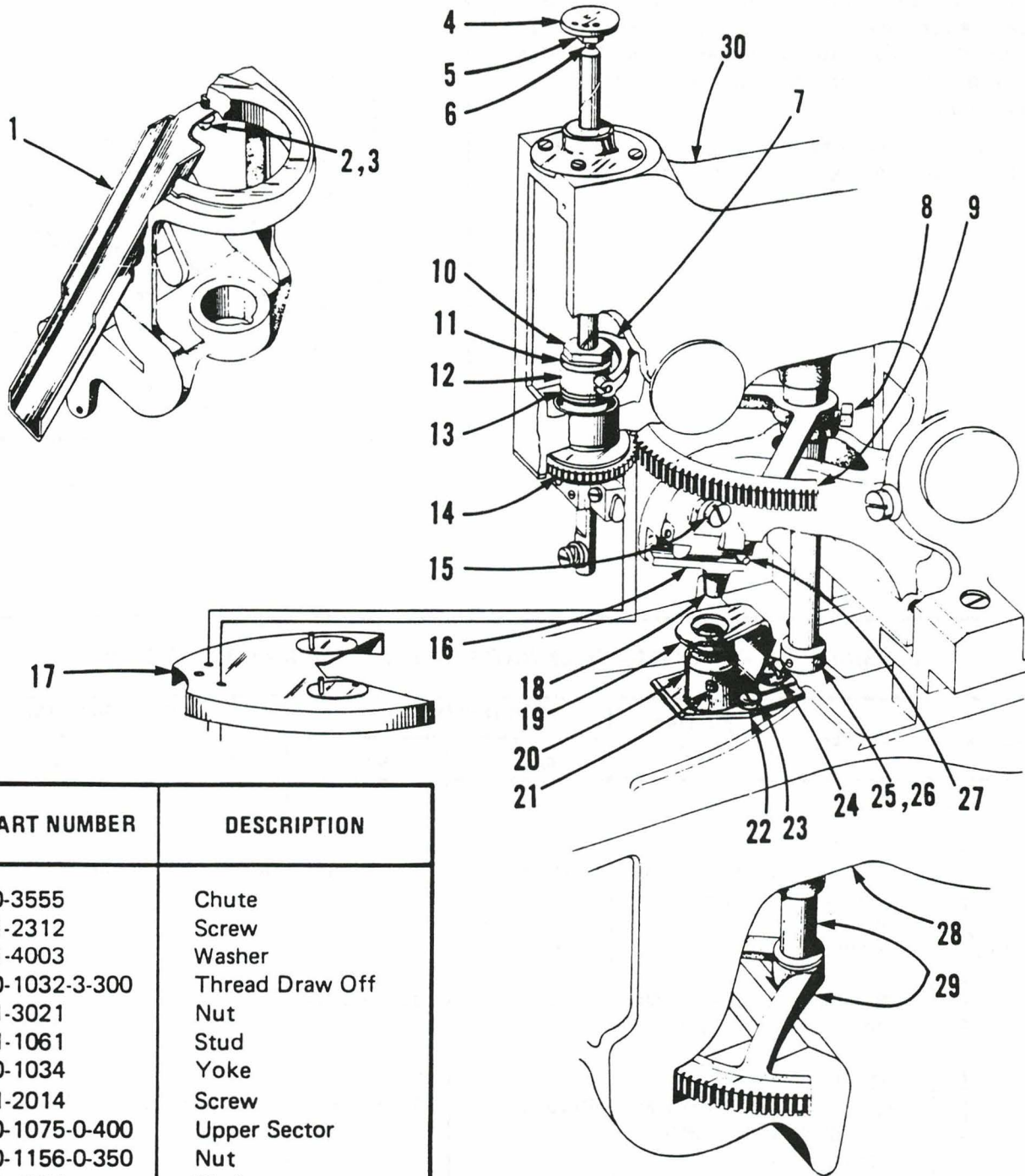

DET.	PART NUMBER	DESCRIPTION
1	10-3555	Chute
2	01-2312	Screw
3	01-4003	Washer
4	10-1032-3-300	Thread Draw Off
5	01-3021	Nut
6	01-1061	Stud
7	10-1034	Yoke
8	01-2014	Screw
9	10-1075-0-400	Upper Sector
10	10-1156-0-350	Nut
11	01-4034	Washer
12	10-1033-0-350	Gimbal
13	01-4027	Washer
14	10-1023-3	Needle Bar Gear
15	01-2027	Screw
16	10-1164	Clamp
17	10-1145-0-400	Shield
18	See pages 34-36	Cutting Steel
19	10-3556-0-008	Cloth Support (S)
	10-3556-0-009	Cloth Support (M)
20	See pages 34-36	Cutter
21	10-1031	Screw
22	10-3554	Cutter Holder

23	01-2039	Screw
24	01-2115	Screw
25	01-2028	Screw
26	10-3010	Collar
27	01-6026	Stop Pin
28	10-3001-2-350	Cam Case
29	10-3009-0-400	Lower Sector & Shaft
30	10-1001-2-351	Head

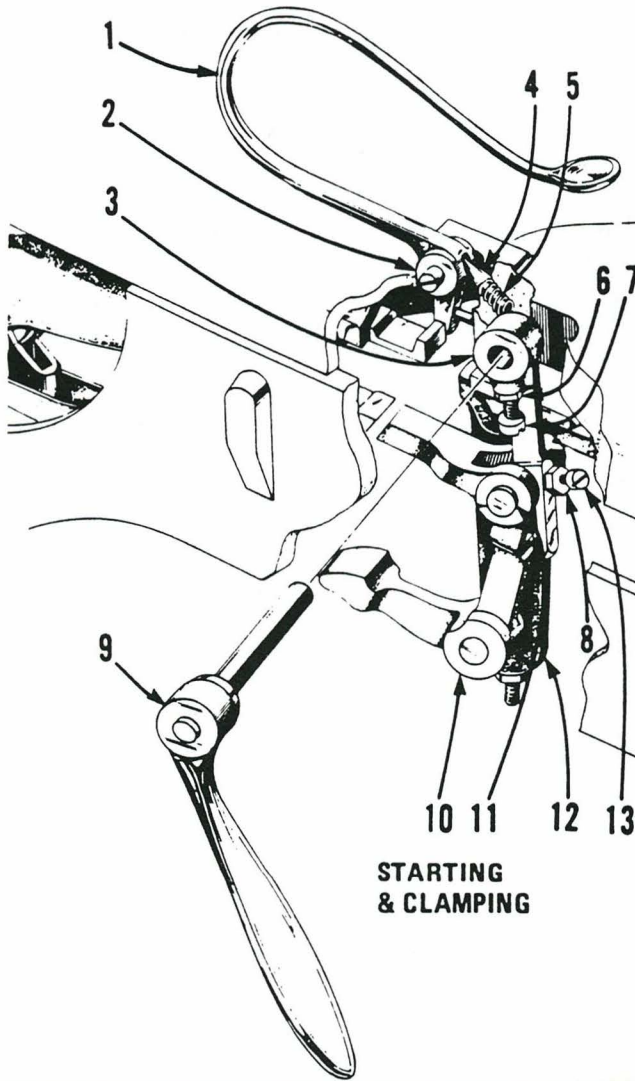

STARTING & CLAMPING

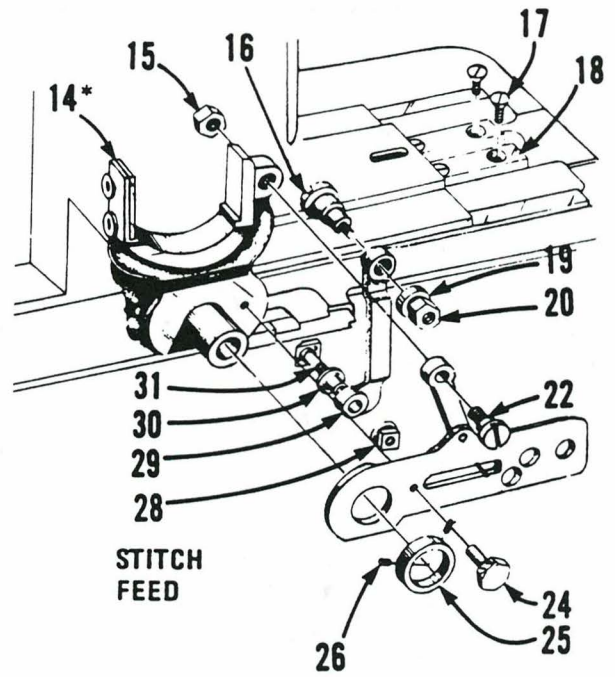

STITCH FEED

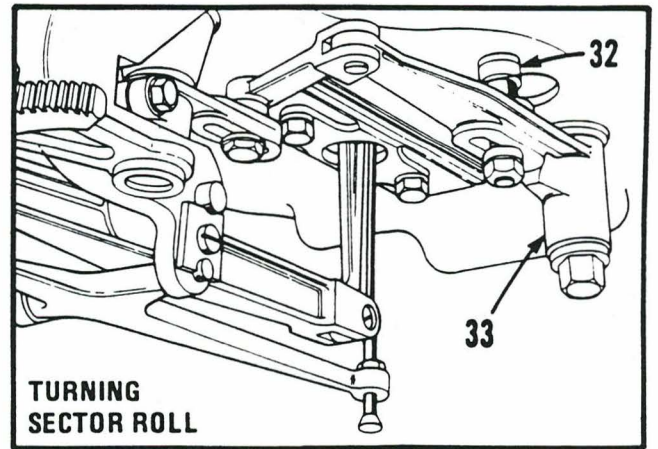

TURNING SECTOR ROLL

DET.	PART NUMBER	DESCRIPTION
1	10-2013-0-350	Starting Lever
2	10-2014	Pivot Screw
3	10-2570	Lever
4	10-2015	Plunger
5	01-5020	Spring
6	01-3001	Nut
7	01-2398	Screw
8	01-3016	Nut
9	10-2569	Hand Clamping Lever
10	10-2021-1-350	Toggle Lever
11	10-2022	Pivot Stud
12	10-2023-0-350	Bracket
13	01-2045	Screw
14	14-1108-0-050	Cam Follower
15	01-3009	Nut
16	01-1132	Screw
17	01-2050	Screw
18	10-2300-0-358	Guide Plate (S)
	10-2300-1-350	Guide Plate (M)

19	01-4063	Washer
20	01-3042	Nut
22	10-2011	Screw
24	01-2030	Screw
25	01-7038	Collar
26	01-2028	Screw
28	01-3019	Nut
29	10-1109-2	Link
30	01-7464	Bushing
31	10-3079-0-550	Stud
32	10-3018-0-350	Roll
33	10-3015-0-250	Sector Lever

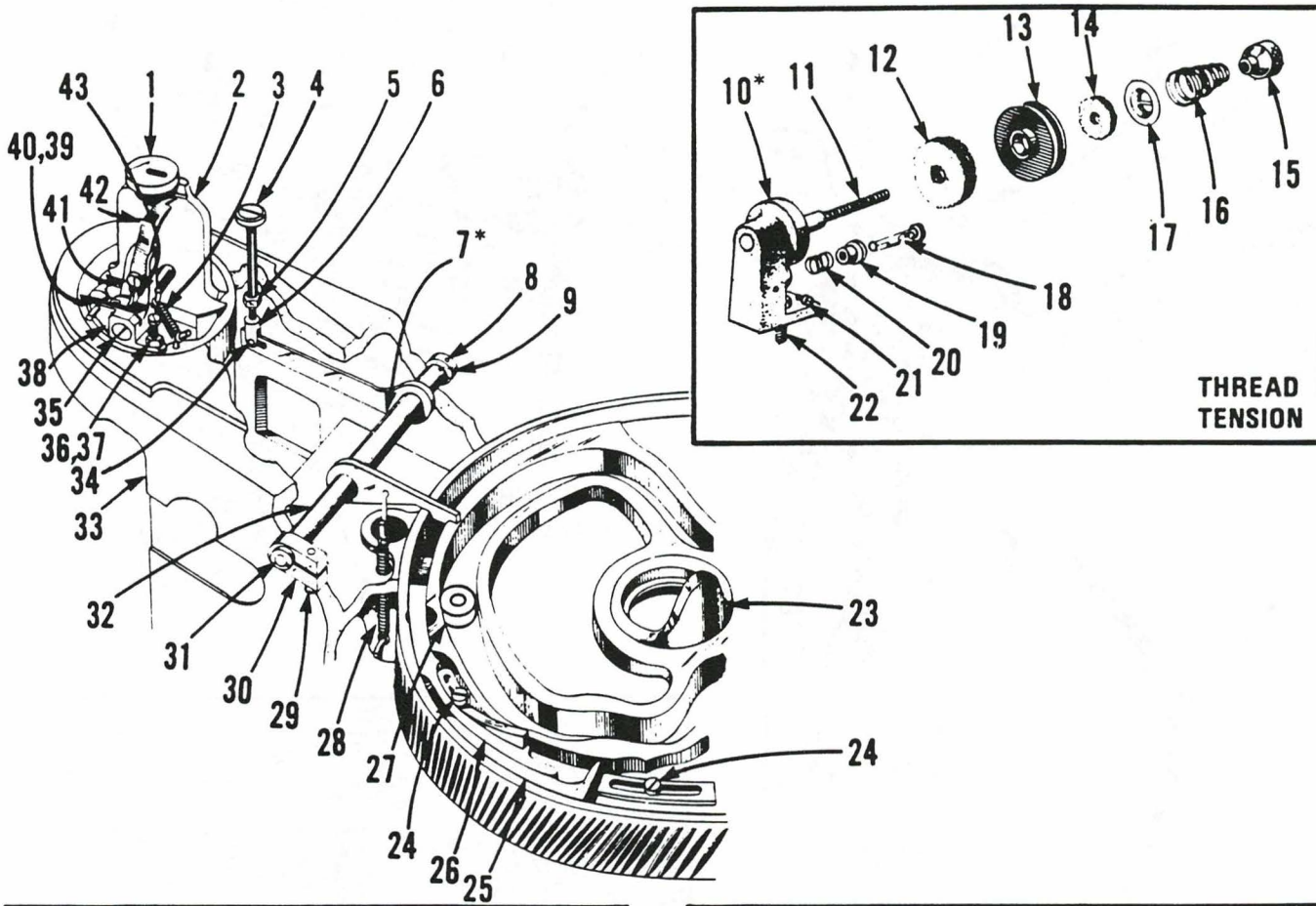

DET.	PART NUMBER	DESCRIPTION
1	10-4012-0-019	Throat Plate (S)
	10-4012-1-019	Throat Plate (M)
2	10-4001-1-150	Race
3	01-5041	Spring
4	10-3206	Actuator
5	01-3016	Nut
6	10-3205	Clevis
7	10-3634-0-351	Trimming Lever
8	01-2194	Screw
9	01-7435-1	Collar
10	10-1013-1-050	Tension Bracket
11	01-1113	Stud
12	10-1077	Felt
13	10-1078-1	Roller Tension
14	10-1004	Felt
15	10-4030	Nut
16	01-5603	Spring
17	10-1003	Washer
18	10-1008	Guide
19	10-1009	Bushing
20	01-5002	Spring
21	01-2001	Screw

22	01-2002	Screw
23	10-3062-1	Cutting Cam
24	01-2079	Screw
25	10-3550-2	Short Stitch Ring
26	10-3551-2	Long Stitch Ring (S)
	10-3551-2-006	Long Stitch Ring (M)
27	10-2007-0-350	Roll
28	01-5038	Spring
29	01-2024	Screw
30	10-3090	Clamp
31	10-3091	Shaft
32	01-7439	Split Bushing
33	10-3001-2-350	Cam Case
34	01-6010	Pin
35	14-4201	Stud
36	01-3025	Nut
37	01-2361	Screw
38	10-4202-0-402	Holder
39	01-2318	Screw
40	01-4015	Washer
41	01-2081	Screw
42	10-4600	Knife
43	10-4203	Spring
44	10-3064-0-019	Main CAM RDE Small
	10-3064-1-020	Main CAM RDE Medium
	10-3064-1-021	Main CAM RDE Large

FOR 'M' MODELS ONLY

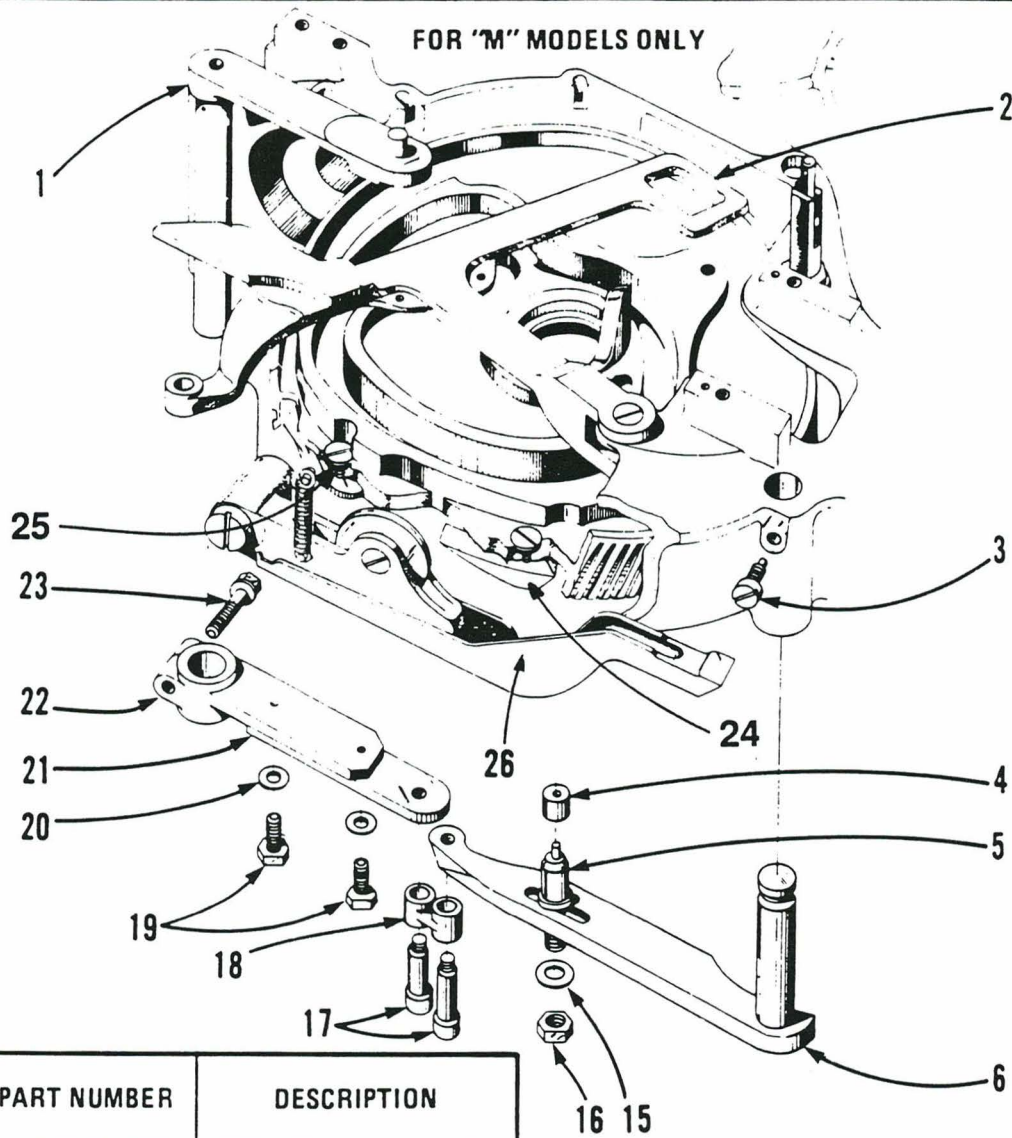

DET.	PART NUMBER	DESCRIPTION
1	10-3034-0-300	Upper Lateral Lever
2	10-3029-1-350	Shifting Lever
3	01-2324	Screw
4	01-7004	Roll
5	10-3020-0-006	Stud
6	10-3303	Combination Lever
7	01-1446	Pivot Screw
8	10-1113-0-350	Three Fork Lever
9	01-1445	Clamp Screw
10	01-2050	Screw
11	01-5460	Spring
12	01-5459	Flat Spring
13	01-3020	Nut
14	10-1179	Latch
15	01-4005	Washer
16	01-3013	Nut
17	10-3301-1-006	Screw
18	10-3302	Link
19	01-2085	Screw
20	01-4006	Washer
21	10-3300-0-006	Lower Lateral Ext.

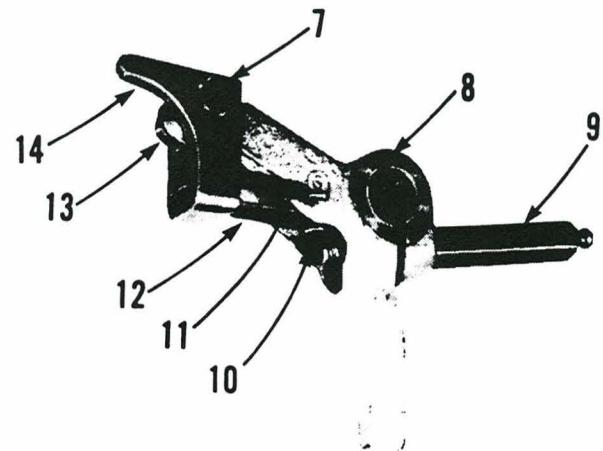

22	10-3019-1-006	Lower Lateral Lever
23	01-2016	Screw
24	10-3061-0-350	Wedge (CAM Clamping)
25	10-3200-0-350	Wedge (Unclamping Wedge)
26	10-3022-1-350	Arm



## CROSS OVAL MODEL

DESCRIPTION	PRODUCT CODE NO.
OVAL	10-051

This section contains parts special to the Cross Oval model. All other parts are standard and should be found in the Adjustable Flybar section of this manual.

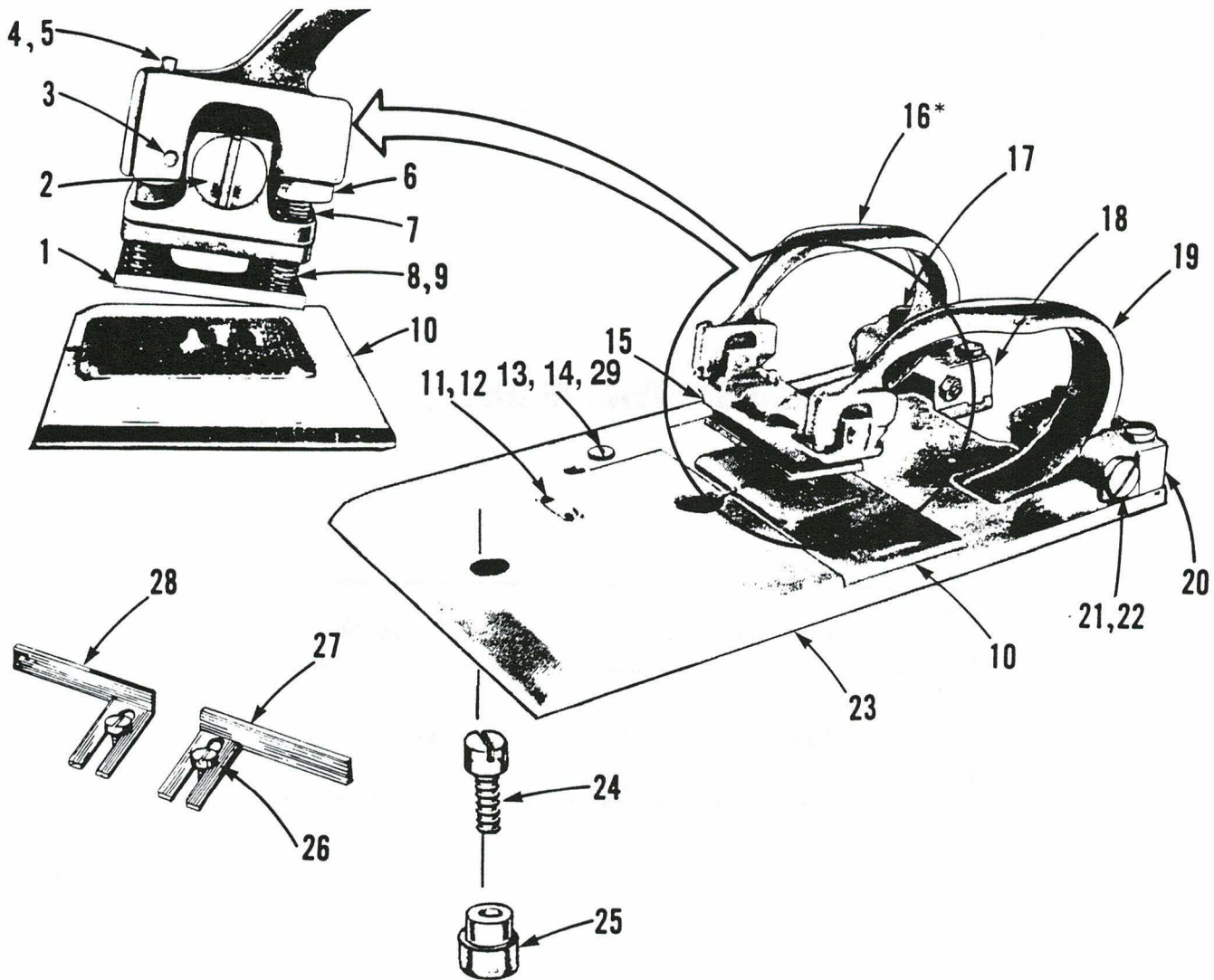

DET.	PART NUMBER	DESCRIPTION
1	10-2604-2-012	Pressure Plate, 3/8"
	10-2604-2-018	Pressure Plate, 9/16"
	10-2604-2-024	Pressure,Plate, 3/4"
2	01-1441	Screw
3	01-6577	Pin
4	01-6352	Plunger
5	01-5077	Springer
6	01-3025	Nut
7	01-2586	Screw
8	01-5457	Spring
9	01-6571	Retaining Ring
10	10-2600-3-012	Mat, 3/8"
	10-2600-3-018	Mat, 9/16"
	10-2600-3-024	Mat, 3/4"
11	01-2053	Screw
12	01-2054	Clip
13	10-2563	Latch

14	01-2056	Screw
15	10-2603-2-062	Foot Asm., 3/8"
	10-2603-2-068	Foot Asm., 9/16"
	10-2603-2-074	Foot Asm., 3/4"
16	10-2602-3-050	Clamp Arm Asm, Left
17	01-2051	Screw
18	10-2554-0-400	Block, Left
19	10-2601-3-050	Clamp Arm Asm, Right
20	10-2555-0-400	Block, Right
21	01-1442	Screw
22	01-3001	Nut
23	10-2553-0-400	Clamp Plate
24	01-1449	Eccentric Screw
25	01-3439	Nut
26	01-2111	Screw
27	10-2567-0-400	Cloth Gauge, Right
28	10-2566-0-400	Cloth Gauge, Left
29	01-5102	Spring

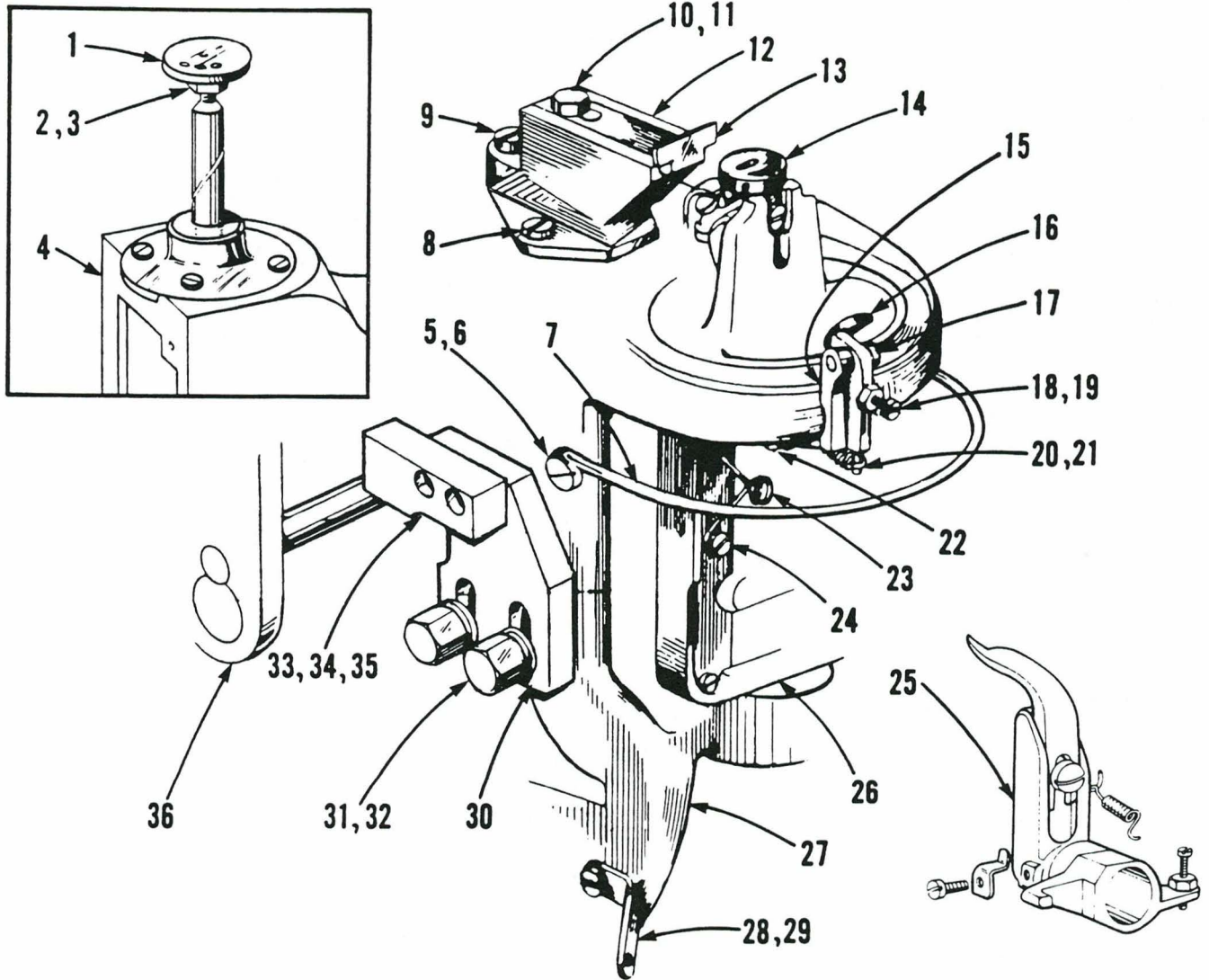

DET.	PART NUMBER	DESCRIPTION
1	10-1032-3-300	Thread Draw Off
2	01-3021	Nut
3	01-1061	Stud
4	10-1001-2-351	Head
5	01-2017	Screw
6	01-4006	Washer
7	10-3613	Wire
8	01-2039	Screw
9	01-2038	Screw
10	01-2074	Screw
11	01-4011	Washer
12	10-3058-0-400	Cutter Holder
13	10-3606	Cutter
14	10-4012-0-012	Throat Plate
15	10-3610	Trimmer Bracket
16	10-3604-1	Trimmer Cam
17	01-2087	Screw

18	01-2007	Screw
19	01-3025	Nut
20	01-6527	Anchor
21	01-5041	Spring
22	01-2079	Screw
23	10-4550	Cord Guide
24	01-2073	Screw
25	10-4202-0-402	Trimmer Holder
26	10-4001-1-150	Race, CA
27	10-3001-0-400	Cam Case
28	10-3607-1	Lower Cord Guide
29	01-2050	Screw
30	10-3611	Bracket
31	01-2020	Screw
32	01-4024	Washer
33	10-3612	Cam Slide
34	01-2024	Screw
35	01-4042	Washer
36	10-2023-0-007	Bracket

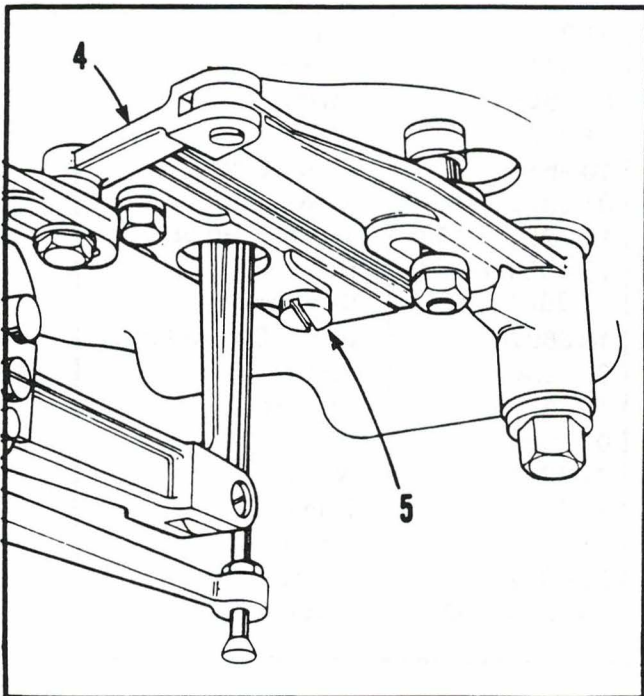
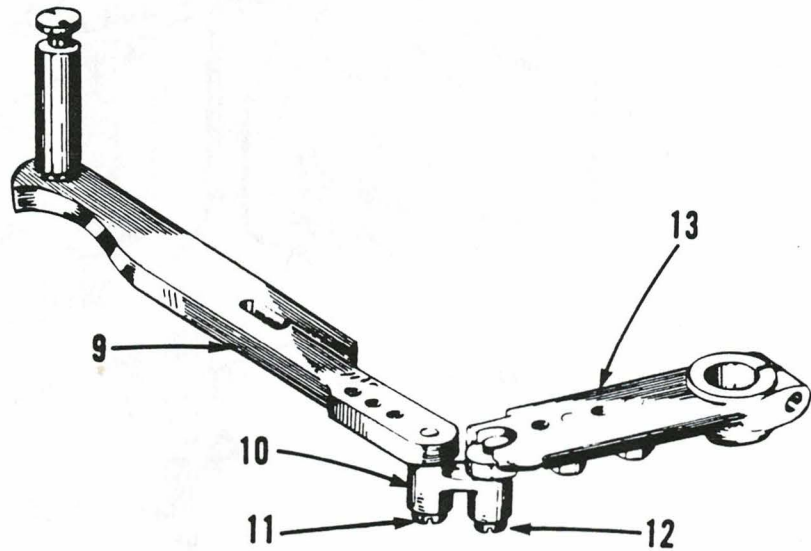
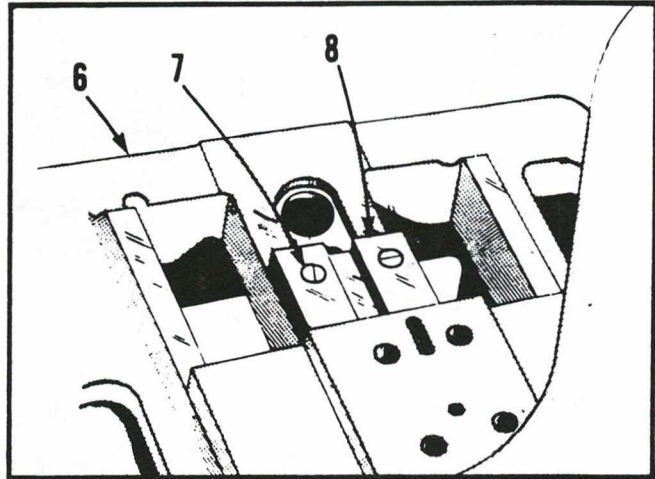
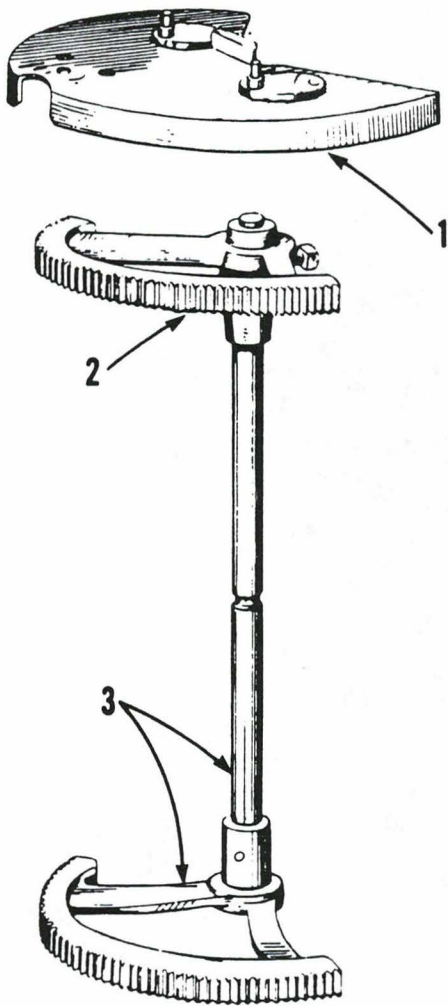

DET.	PART NUMBER	DESCRIPTION
1	10-1145-0-400	Shield
2	10-1075-0-400	Sector, Upper
3	10-3009-0-400	Sector, Lower & Shaft
4	10-3012-0-400	Link
5	01-2170	Screw
6	10-2001-1-350	Bed Plate
7	01-2050	Screw
8	10-2605	Guide Plate
9	10-3609-1	Combination Lever
10	10-3302	Link
11	10-3608	Screw
12	10-3301-0-400	Screw
13	10-3019-1-400	Lower Lateral Lever

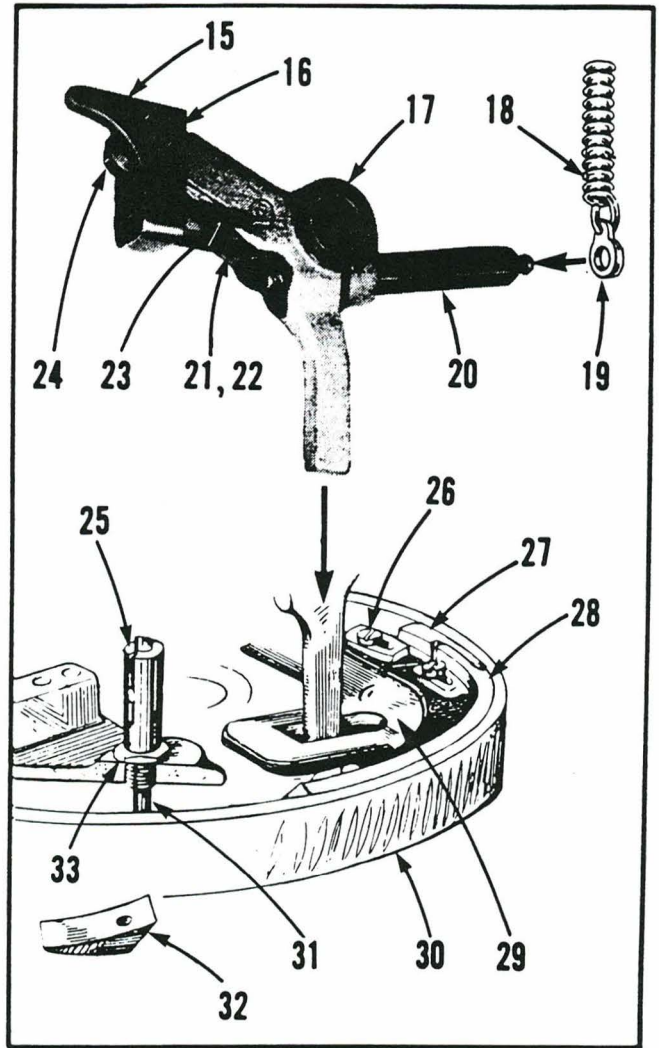
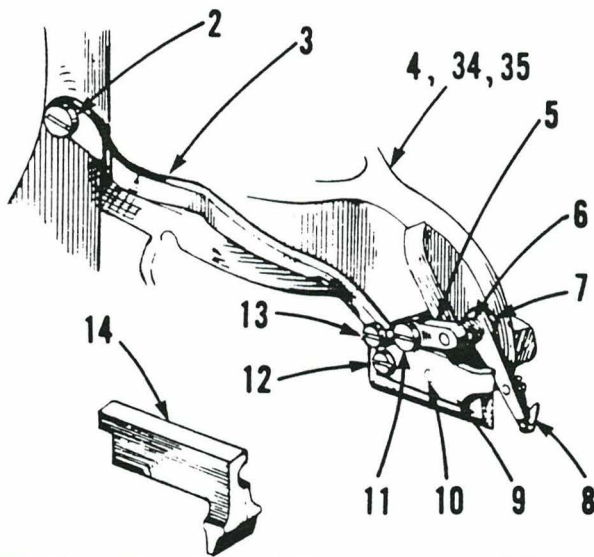
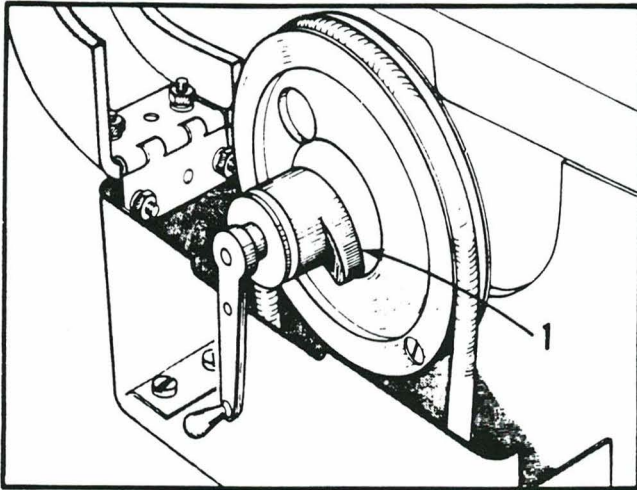

DET.	PART NUMBER	DESCRIPTION
1	10-1194-0-026	Hub
2	10-1214	Screw
3	10-1205-0-400	Lever
4	10-1154-0-401	Cutting Lever Asm.
5	10-1206	Link
6	01-5076	Spring
7	10-1208-0-400	Screw
8	10-1207-0-400	Pickup Hook
9	10-1204-0-400	Adjustable Plate
10	01-6009	Pivot Pin
11	10-1210-1	Pivot Screw
12	01-2006	Adjusting Screw
13	10-1209	Screw
14	10-1600-0-012	Cutting Steel, 3/8"
	10-1600-0-016	Cutting Steel, 1/2"
	10-1600-0-018	Cutting Steel, 9/16"
	10-1600-0-020	Cutting Steel, 5/8"
	10-1600-0-024	Cutting Steel, 3/4"

15	10-1179	Latch
16	01-1446	Pivot
17	10-1113-0-350	Three Fork Lever
18	01-5013	Spring
19	10-1116	Clip
20	01-1445	Clamp Screw
21	01-5459	Flat Spring
22	01-2050	Screw
23	01-5460	Spring
24	01-3020	Nut
25	10-3426	Stitch Rod Bushing
26	01-2079	Screw
27	10-3601	Short Stitch Ring
28	10-3600	Long Stitch Ring
29	10-3029-1-400	Shifting Lever
30	10-3064-0-025	Main Cam
31	10-3502	Stitch Rod
32	10-3061-0-300	Clamping Wedge
33	01-3026	Nut
34	10-1164	Clamp
35	01-6837-0-001	Pin



## CUT-BEFORE/CUT-AFTER EDGING MODELS

CUT-BEFORE EDGING MODEL	
DESCRIPTION	PRODUCT CODE NO.
CB-ED	10-047

This section contains parts special to Cut-Before Edging and Cut-After Edging models. All other parts are standard and should be found in the Adjustable Flybar section of this manual.

CUT-AFTER EDGING MODEL	
DESCRIPTION	PRODUCT CODE NO.
CA-ED-XL	10-048

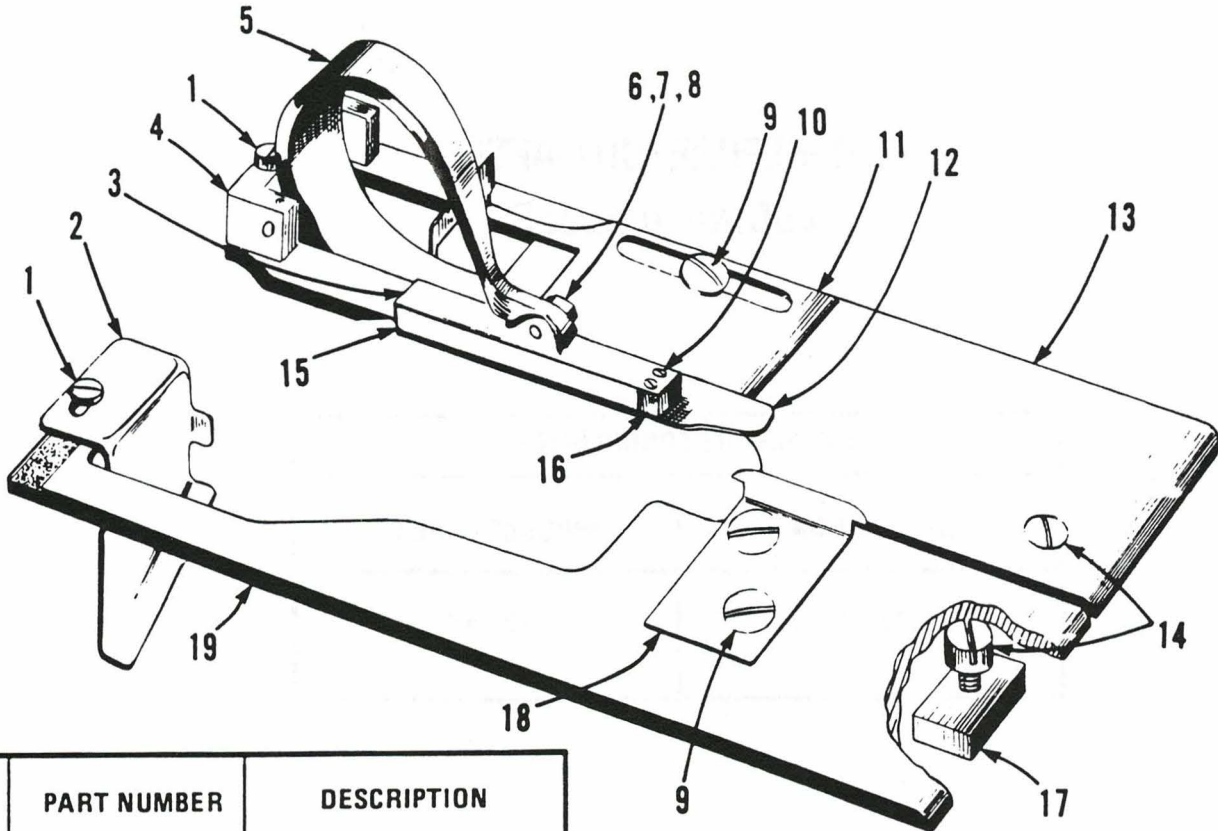

DET.	PART NUMBER	DESCRIPTION
1	01-2387	Screw
2	10-2633	Chip Guard
3	10-2801-1-055	Clamp Foot
4	10-2045-0-450	Block
5	10-2800-0-012	Clamp Arm
6	01-1137	Screw
7	01-3016	Nut
8	01-4038	Washer
9	01-2111	Screw
10	01-2015	Screw
11	10-2059-1	Cloth Guide
12	10-2044-0-021	R.H. Mat
13	10-2043-0-450	R.H. Clamp Plate
14	01-1105	Screw
15	10-2802-0-004	Neoprene Soul
16	10-2629	Block
17	10-2626	Block
18	10-2627-1	Cloth Gauge
19	10-2047-0-450	L.H. Clamp Plate
20	10-1156	Nut
21	01-4034-0-001	Shim (Oversized)
	01-4034-0-002	Shim (Oversized)
	01-4034-0-003	Shim (Oversized)
22	10-1150-0-450	Plate
23	10-3079-0-550	Stud
24	01-7464	Bushing
25	10-1109-2	Link

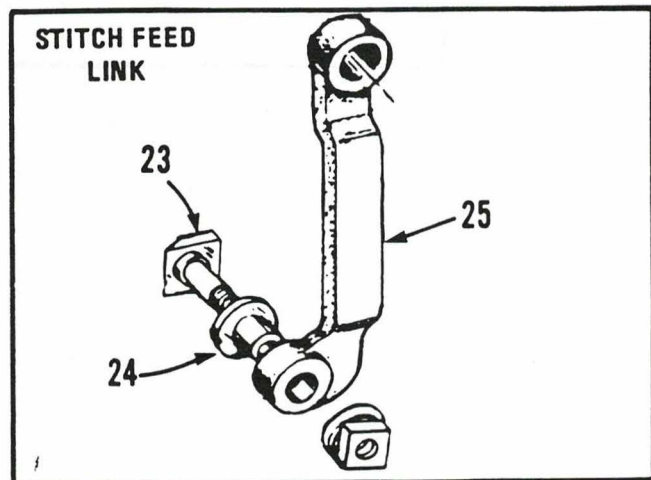
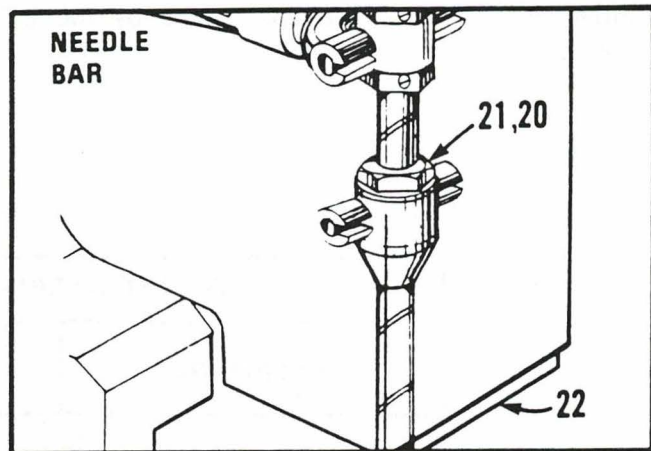

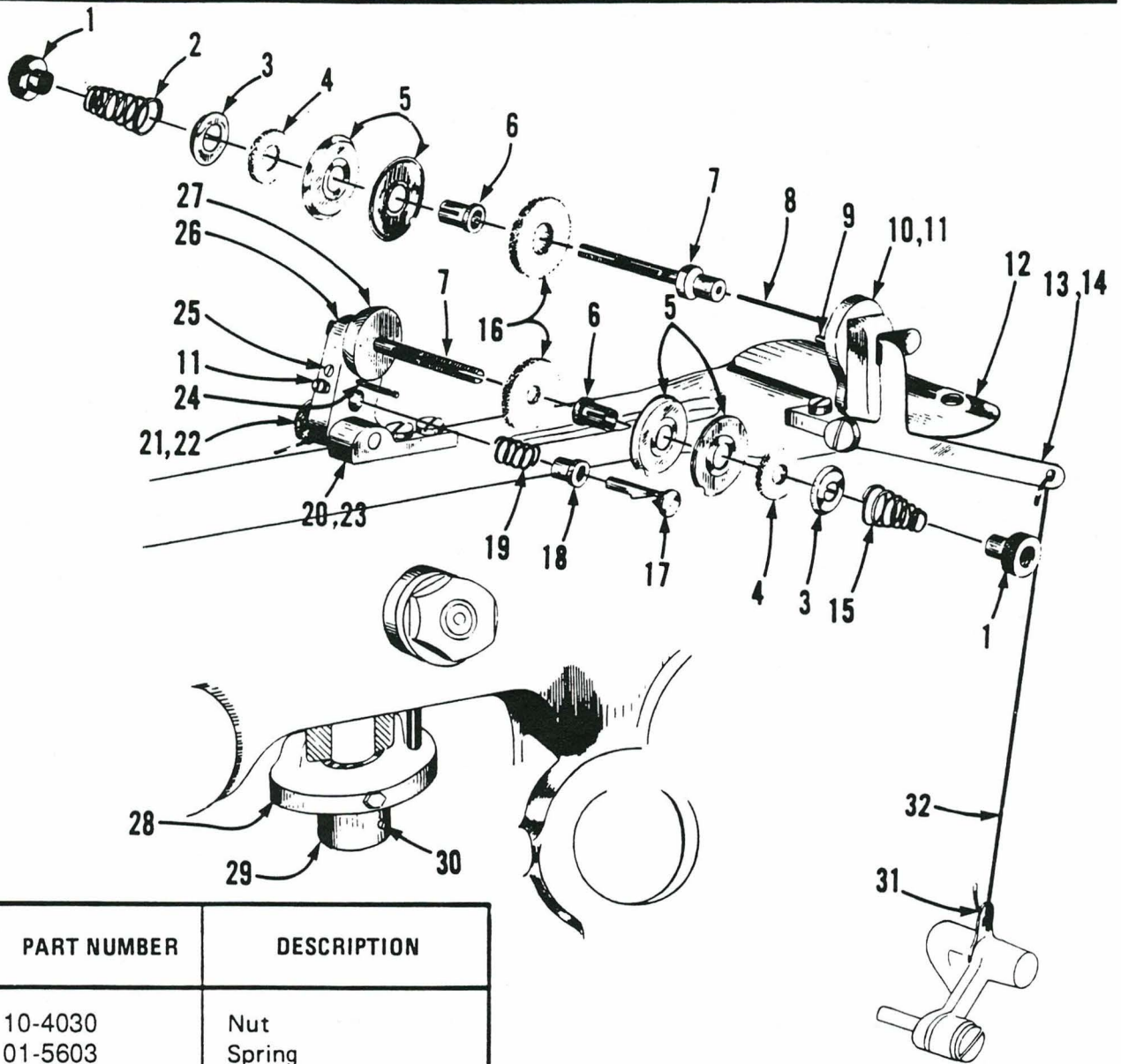

DET.	PART NUMBER	DESCRIPTION
1	10-4030	Nut
2	01-5603	Spring
3	10-1003	Release Washer
4	10-1004	Thin Felt
5	10-1005	Split Tension Disc
6	10-1007	Bushing
7	01-1113	Stud
8	01-6337	Rod
9	10-1011	Pin
10	10-1013-1-050	Tension Bracket Asm.
11	01-2001	Set Screw
12	10-1162	Cover Plate
13	10-1630	Lever
14	01-1112	Screw
15	01-5603	Spring
16	10-1077	Thick Felt
17	10-1008	Guide
18	10-1009	Bushing
19	01-5002	Spring
20	01-2039	Screw

21	01-1114	Screw
22	01-5163	Spring
23	10-1159	Bracket
24	01-6042	Pin
25	01-2361	Screw
26	10-1158-1-050	Tension Arm Asm.
27	01-4074	Spacer
28	10-1633	Collar
29	10-3010	Collar
30	01-2028	Set Screw
31	10-1632	Link
32	10-1631	Tension Release

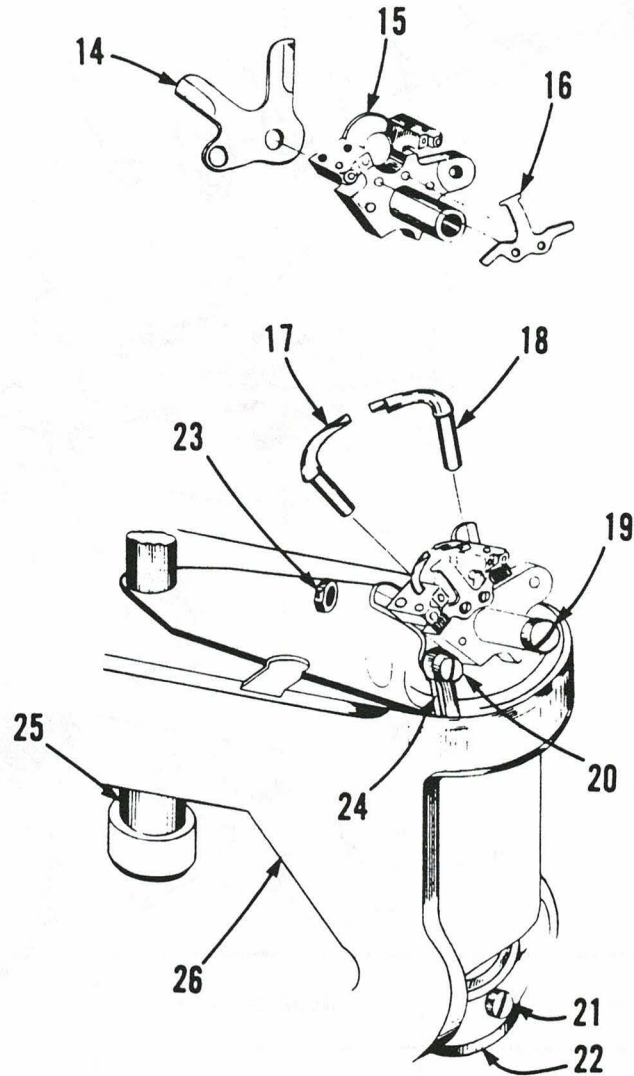
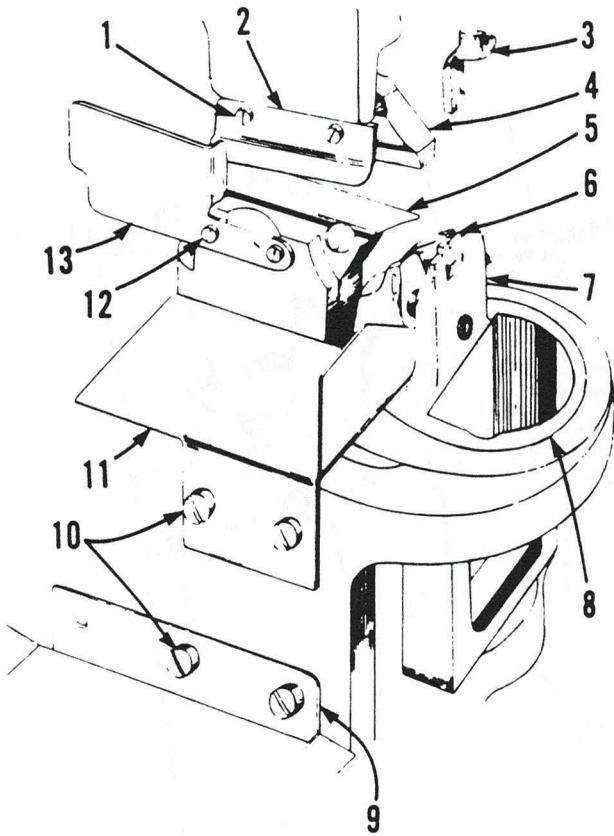

DET.	PART NUMBER	DESCRIPTION
1	01-2054	Screw
2	10-1634	Cloth Pusher
3	10-4012-1-017	Throat Plate
4	10-1069-0-100	Cutting Steel
5	10-3072-0-068	Knife
6	10-4634-0-010	Thread Grabber Hook
7	01-2371	Screw
8	10-4001-0-460	Race
9	10-3630-1	Lower Chute
10	01-2175	Screw
11	10-3629-2	Upper Chute
12	01-2131	Screw
13	10-3640	Cloth Gauge

14	10-4011-0-450	Spreader Wedge
15	10-4002-0-016	Looper Carrier
16	10-4010-0-450	Needle Guard
17	10-4005-2-986	Looper Left-short Point W/O Prong
18	10-4004-0-008	Right Short point
19	01-2070	Screw
20	01-1116	Screw
21	01-2130	Screw
22	10-4025-0-450	Bushing
23	01-3005	Nut
24	10-4015-0-450	Short Link
25	10-3009-0-450	Sector Shaft
26	10-3001-1-450	Cam Case

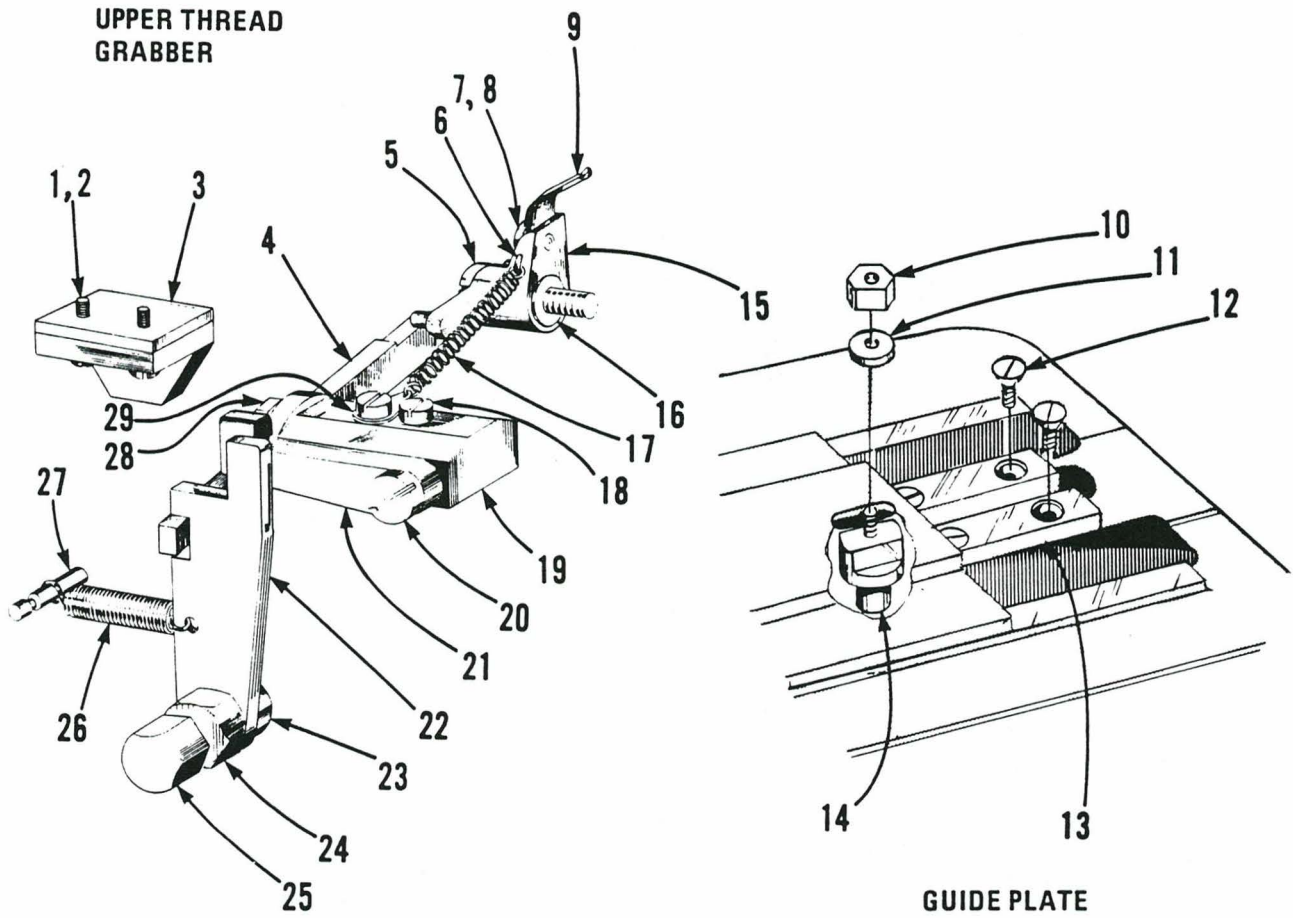

DET.	PART NUMBER	DESCRIPTION
1	01-2059	Screw
2	01-4067	Washer
3	10-2200-1-450	Bumper
4	10-3626-3	Link
5	01-1118	Screw
6	01-6002	Anchor
7	01-2365	Screw
8	01-4076	Washer
9	10-4634-0-010	Thread Grabber Hook
10	01-3007	Nut
11	01-4024	Washer
12	01-2050	Screw
13	10-2300-1-021	Guide Plate
14	10-1301	Stud/Roll
15	10-4202-1-460	Hook Holder
16	01-4042	Washer
17	01-5164	Spring
18	01-2037	Screw

19	10-3625-2	Bracket
20	01-1057	Screw
21	10-3633	Lever
22	10-3631-2	Lever
23	01-7035	Washer
24	10-3632	Eccentric Stud
25	01-2020	Screw
26	01-5040	Spring
27	01-6014	Anchor
28	01-1115	Screw
29	10-3627	Spring Clip

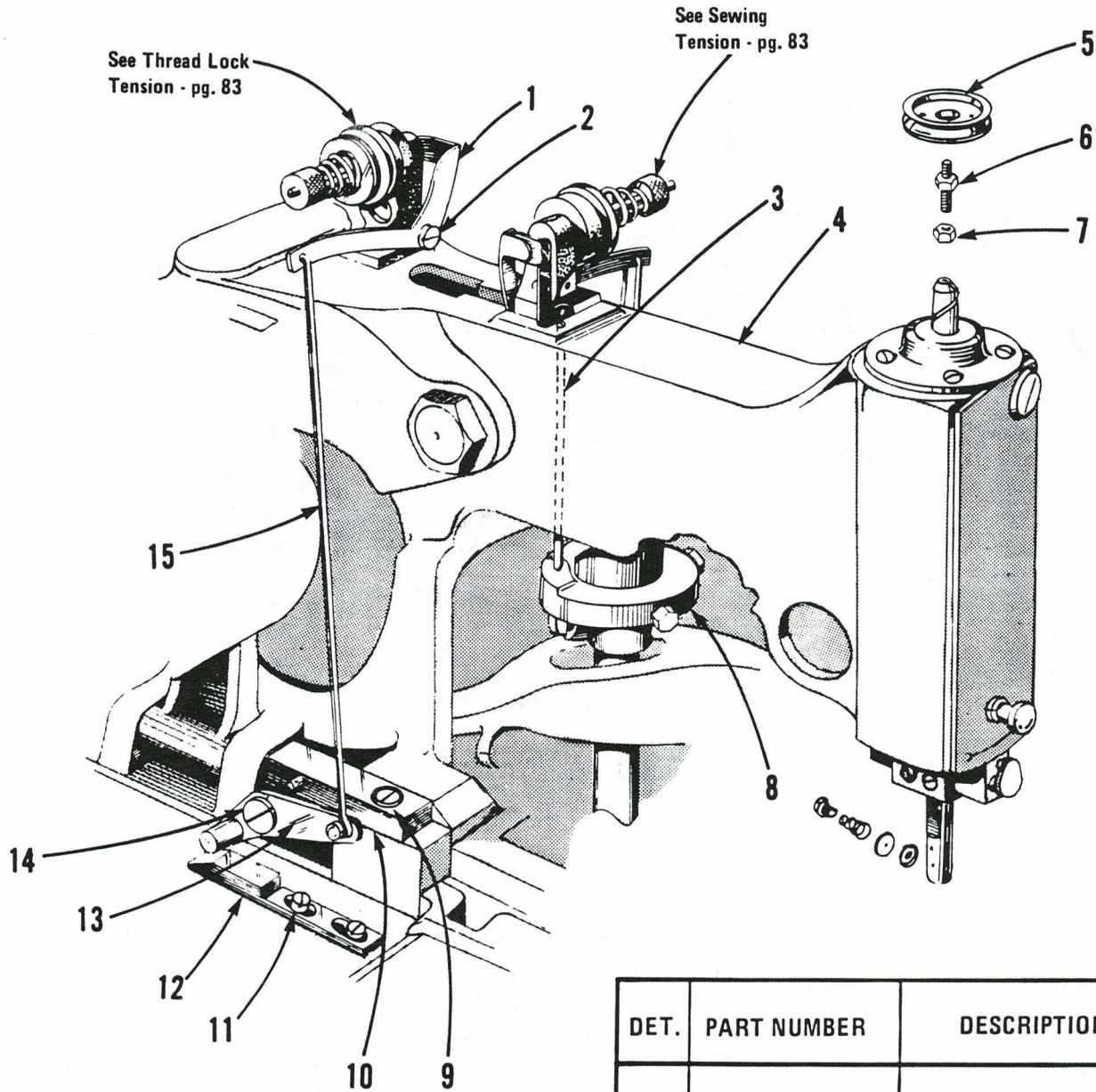

DET.	PART NUMBER	DESCRIPTION
1	10-1012-1	Release Lever
2	01-1112	Screw
3	01-6365	Rod
4	10-1001-0-451	Head
5	10-1032-3-300	Thread Draw-off
6	01-1061	Stud
7	01-3021	Nut
8	10-1160-0-450	Cam
9	01-2041	Screw
10	10-1174	Bracket
11	01-2050	Screw
12	10-2062	Wedge
13	10-1175	Lever
14	01-1103	Screw
15	10-1176	Link

THREAD LOCK TENSION

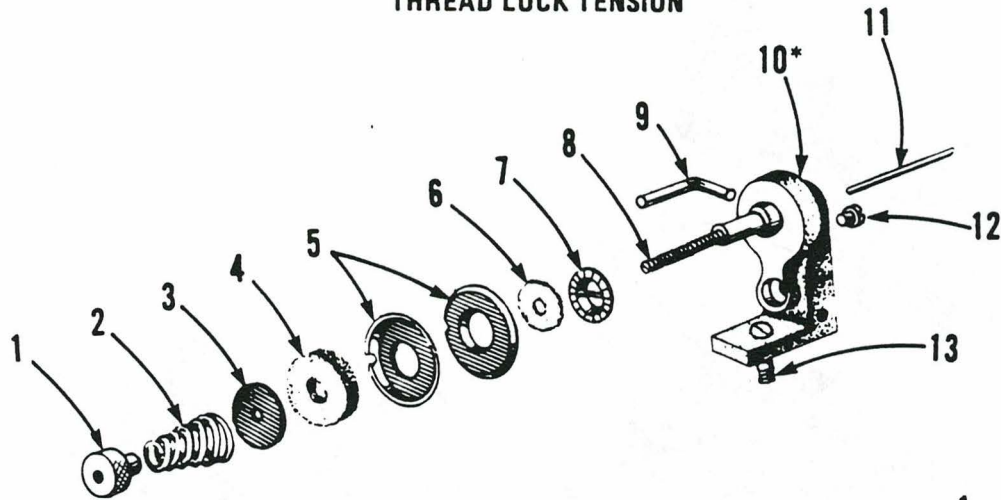

SEWING TENSION

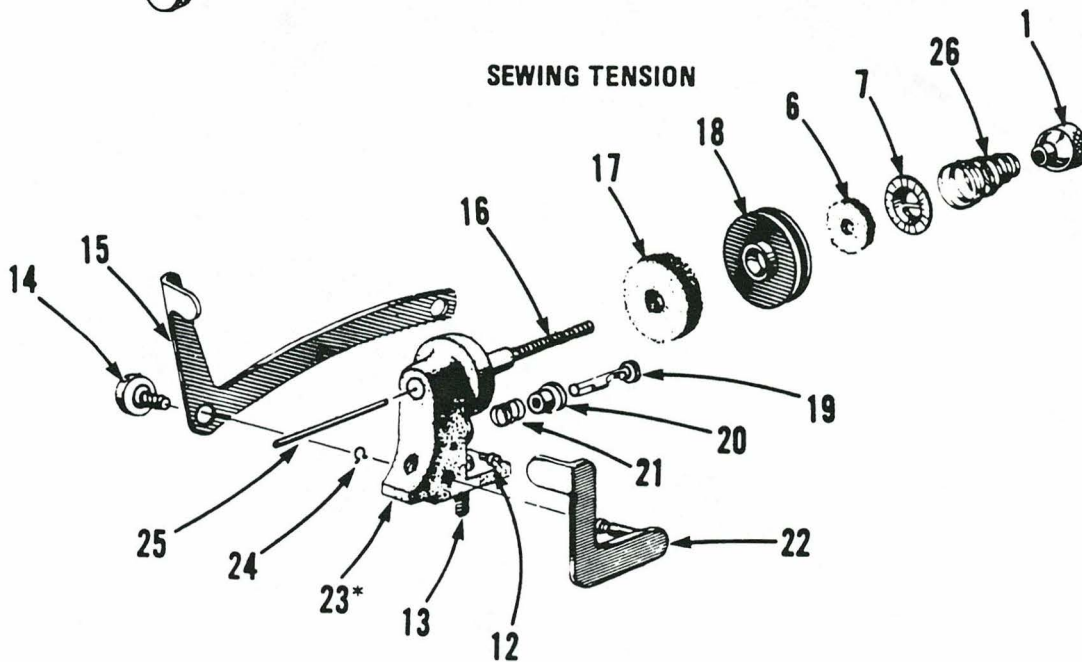

DET.	PART NUMBER	DESCRIPTION
1	10-4030	Nut
2	01-5603	Spring
3	01-4083	Washer
4	10-1006	Felt
5	10-1005	Tension Disc
6	10-1004	Felt
7	10-1003	Release Washer
8	01-1435	Stud
9	01-6369	Locator Pin
10	10-1013-1-050	Tension Bracket
11	10-1010	Release Rod
12	01-2001	Screw
13	01-2002	Screw

14	01-1112	Screw
15	10-1012-1	Release Lever
16	01-1113	Stud
17	10-1077	Felt
18	10-1078-1	Tension Roller
19	10-1008	Guide
20	10-1009	Bushing
21	01-5002	Spring
22	10-1173	Release Lever
23	10-1172-1-000	Tension Bracket
24	01-6368	True
25	01-6367	Release Rod
26	01-5603	Spring

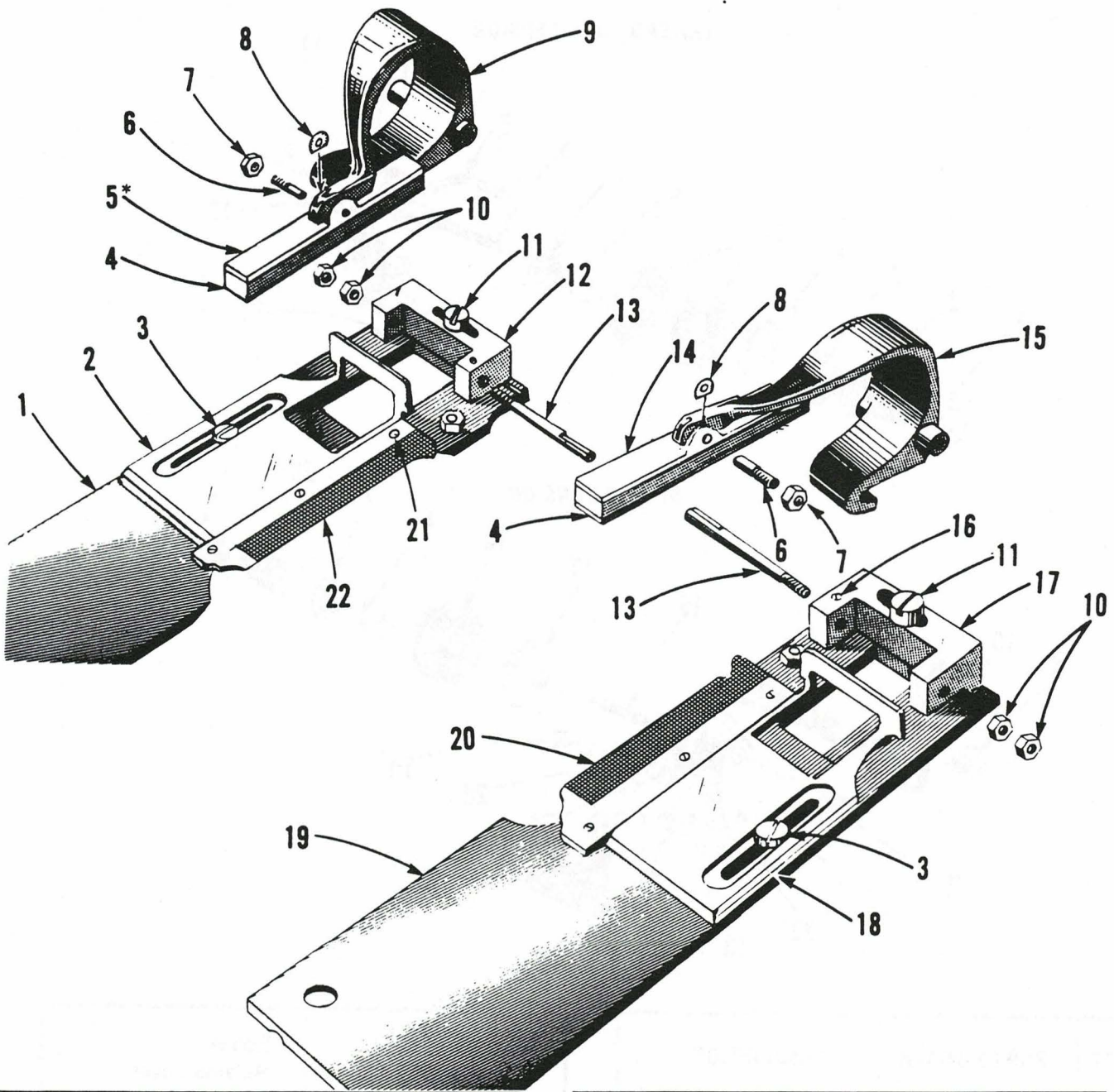

DET.	PART NUMBER	DESCRIPTION
1	10-2047-0-462	Clamp Plate, Left
2	10-2060-1-450	Cloth Guide, Left
3	01-2111	Screw
4	10-2802-0-005	Rubber Pad
5	10-2811-0-053	Clamp Foot, Left
6	01-1137	Screw
7	01-3016	Nut
8	01-4038	Washer
9	10-2810-0-012	Clamp Arm, Left
10	01-3001	Nut
11	01-2051	Screw

12	10-2049-0-462	Block
13	10-2053	Pivot Stud
14	10-2801-0-053	Clamp Foot, Right
15	10-2800-0-012	Clamp Arm, Right
16	01-2052	Screw
17	10-2045-0-462	Block
18	10-2059-0-450	Cloth Guide, Right
19	10-2043-0-462	Clamp Plate, Right
20	10-2044-0-023	Mat, Right
21	01-2015	Screw
22	10-2048-0-022	Mat, Left

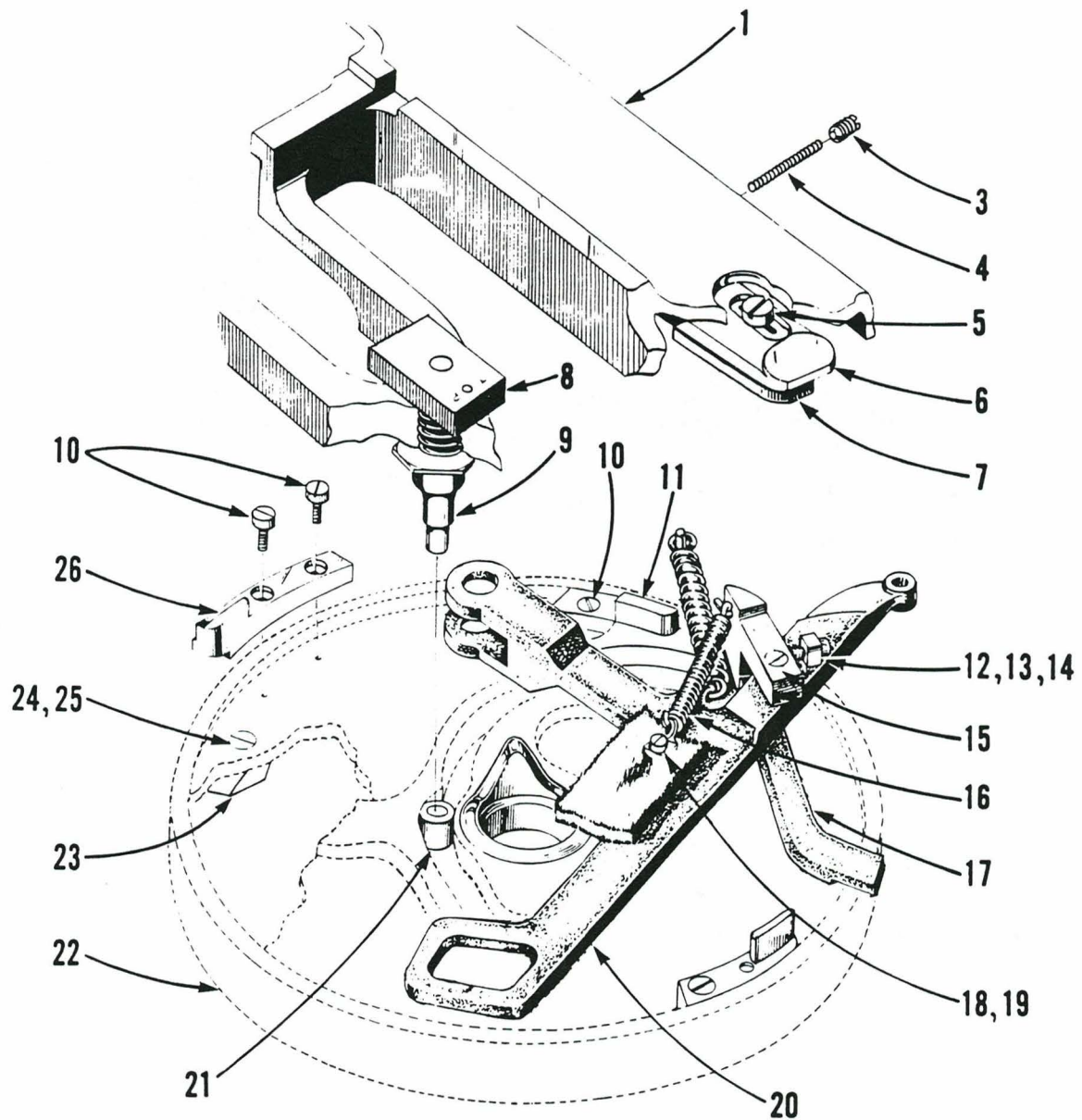

DET.	PART NUMBER	DESCRIPTION
1	10-2001-1-450	Bedplate
3	01-2567	Screw
4	01-5019	Spring
5	01-2027	Screw
6	10-2631	Switch Lever
7	10-2632	Block
8	10-3033-0-450	Block
9	10-2006-0-017	Stud
10	01-2079	Screw
11	10-3636-0-462	Stopping Wedge
12	01-6167	Block
13	01-2045	Screw

14	01-3065	Nut
15	01-1120	Screw
16	01-5126	Spring
17	10-3638-0-462	Stopping Lever
18	01-2004	Screw
19	10-3639	Clip
20	10-3637	Shifting Lever
21	01-7023	Roll
22	10-3064-0-026	Main Cam
23	10-3061-0-462	Clamping Wedge
24	01-2347	Screw
25	01-4061	Washer
26	10-3201-1-462	Trimming Wedge

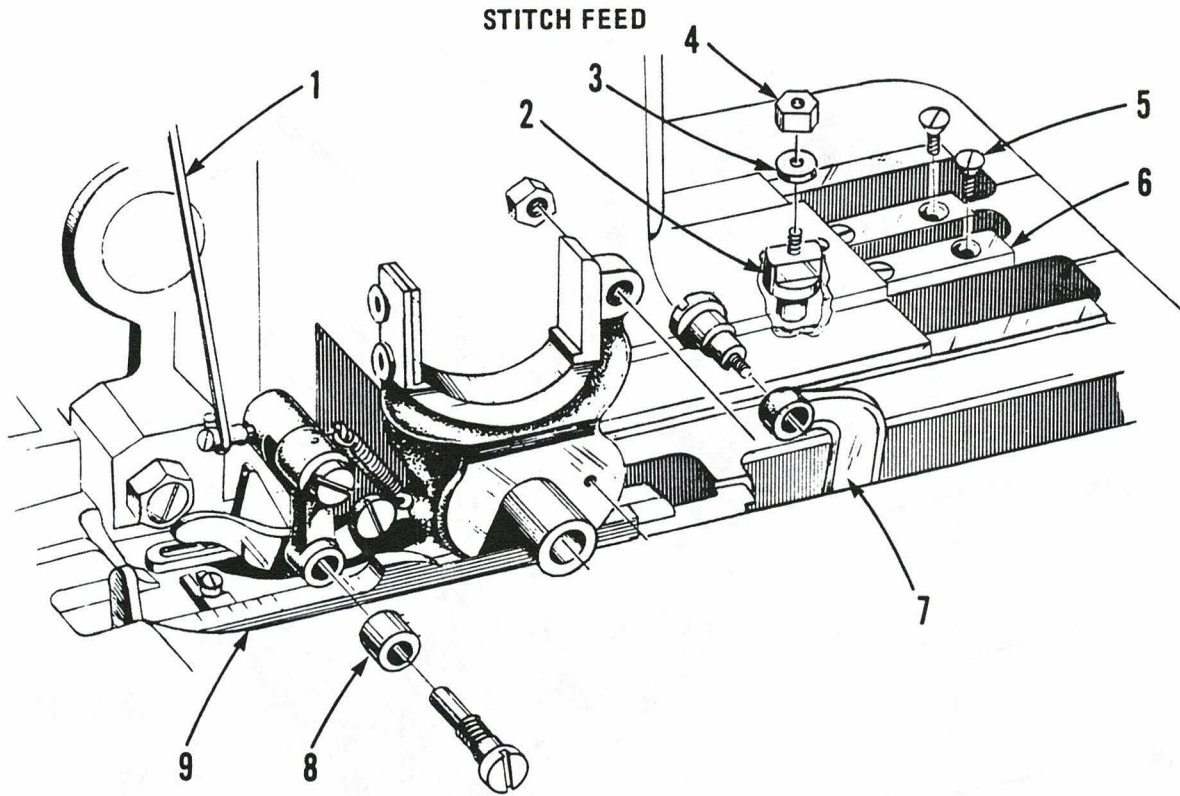

DET.	PART NUMBER	DESCRIPTION
1	10-1083	Link
2	10-1301	Stud + Roll
3	01-4024	Washer
4	01-3007	Nut
5	01-2050	Screw
6	10-2300-1-021	Guide Plate
7	10-1109-2	Lever
8	10-1122-0-017	Roll
9	10-2018-0-450	Length Gauge
10	10-1154-0-050	Cutting Lever Asm.
11	10-1069-0-104	Cutting Steel
12	01-2131	Screw
13	10-3642	Spreading Wedge
14	10-4012-0-023	Throat Plate, RXED
15	10-4012-0-025	Throat Plate, WXED
15	10-4001-0-462	Race
16	10-3058-0-462	Knife Holder
17	10-3072-0-070	Knife

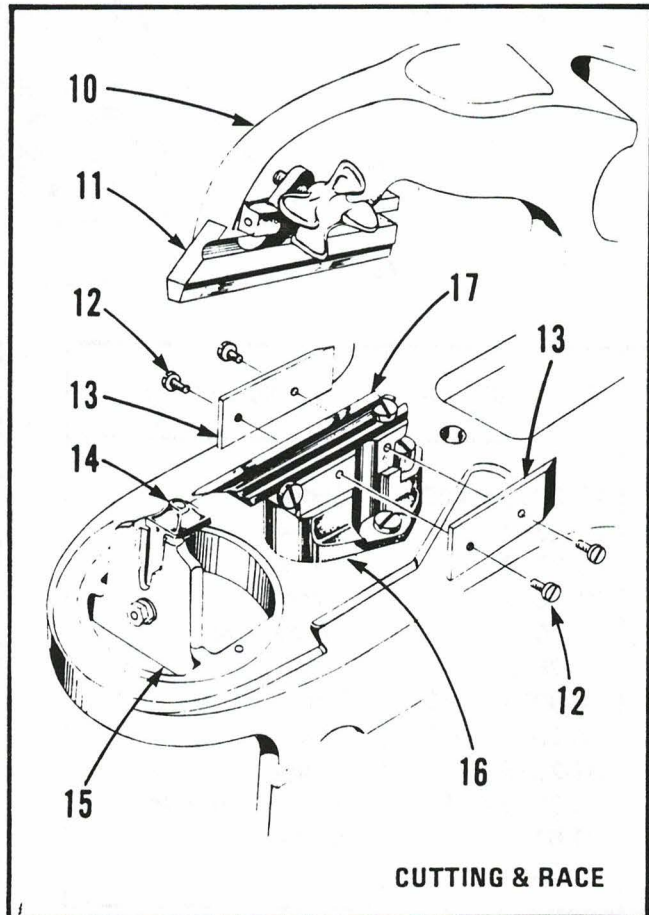

**PARTS COMMON  
TO ALL MODELS**

PART NUMBER	DESCRIPTION
25	10-1142-0-001 CB-R-FE
	10-1142-0-002 CB-R-RE
	10-1142-0-004 CB-L-ME
	10-1142-0-007 CB-R-ME/LE-HH
	10-1142-0-008 CB-R-ME
	10-1142-0-011 CA-R-RE
	10-1142-0-012 CA-R-PE-DG
	10-1142-0-014 CA-R-ME-HH
	10-1142-0-016 AF-CA-RE
	10-1142-0-017 AF-CA-R-RE-MB
	10-1142-0-019 AF-CA-XL-LE
	10-1142-0-022 AF-CB-R-RE
	10-1142-0-023 AF-CB-R-RE
	10-1142-0-024 AF-CB-RL-ME
	10-1142-0-025 AF-CB-RL-LE
	10-1142-0-026 AF-CB-ME/LE-HH
	10-1142-0-028 CB/CA-R-RE
	10-1142-0-030 AF-CB/CA-R-RE
	10-1142-0-032 CT-CA-9/16-RE
	10-1142-0-033 CT-CA-5/8-RE
	10-1142-0-034 CT-CA-5/8-LE
	10-1142-0-035 CT-CA-3/4-RE
	10-1142-0-036 CT-CA-7/8-RE
	10-1142-0-041 CBRCA-5/8-ME
	10-1142-0-043 CBR-CA-7/8-ME
	10-1142-0-044 CBR-CA-1 1/4-ME
	10-1142-0-045 CBR-CA-1 1/8-ME
	10-1142-0-046 CBR-CA-1 1/4-ME
	10-1142-0-047 CB-EDR
	10-1142-0-048 CAED
	10-1142-0-051 CO-1 1/2
	10-1142-0-052 R-de-S
	10-1142-0-053 R-de-M
26	01-2081 screw

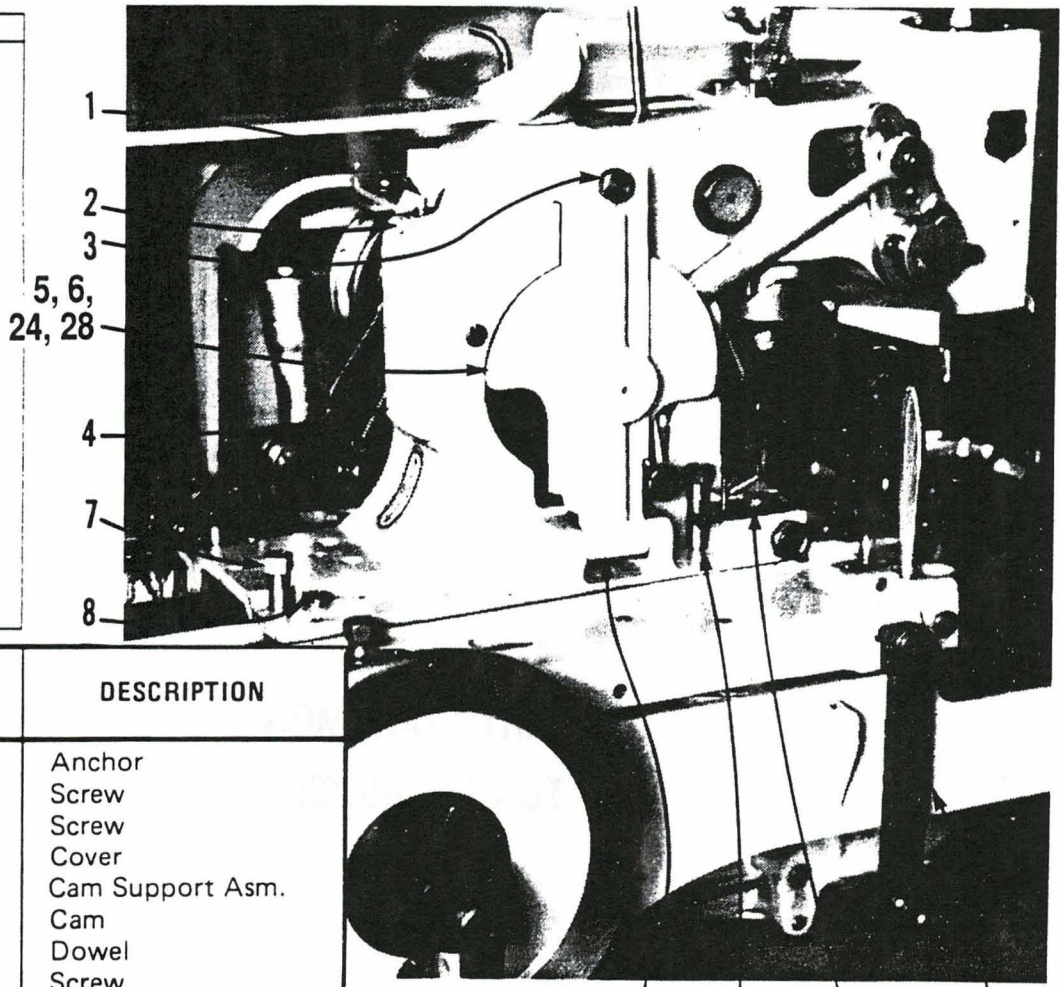

DET.	PART NUMBER	DESCRIPTION
1	01-6014	Anchor
2	10-1081	Screw
3	01-2093	Screw
4	10-1080	Cover
5	10-1190	Cam Support Asm.
6	05-0531-0-001	Cam
7	10-1128	Dowel
8	01-2568	Screw
9	10-1230	Hinge Pin
10	10-1129-1	Dowel
11	01-2343	Screw
12	10-2004	Screw
13	10-2005	Latch
14	10-1134	Guard
15	01-2054	Screw
16	10-1082-0-001	Plate
17	01-5062	Spring Washer
18	10-1151	Screw
19	05-1415-1-115	Light
20	01-3040	Knob
21	01-2028	Screw
22	05-0381	Lamp
23	10-1001-6-050	Head Assembly
24	10-1188	Cam Support
27	05-1212	Plate Cover
28	10-1231	Cover

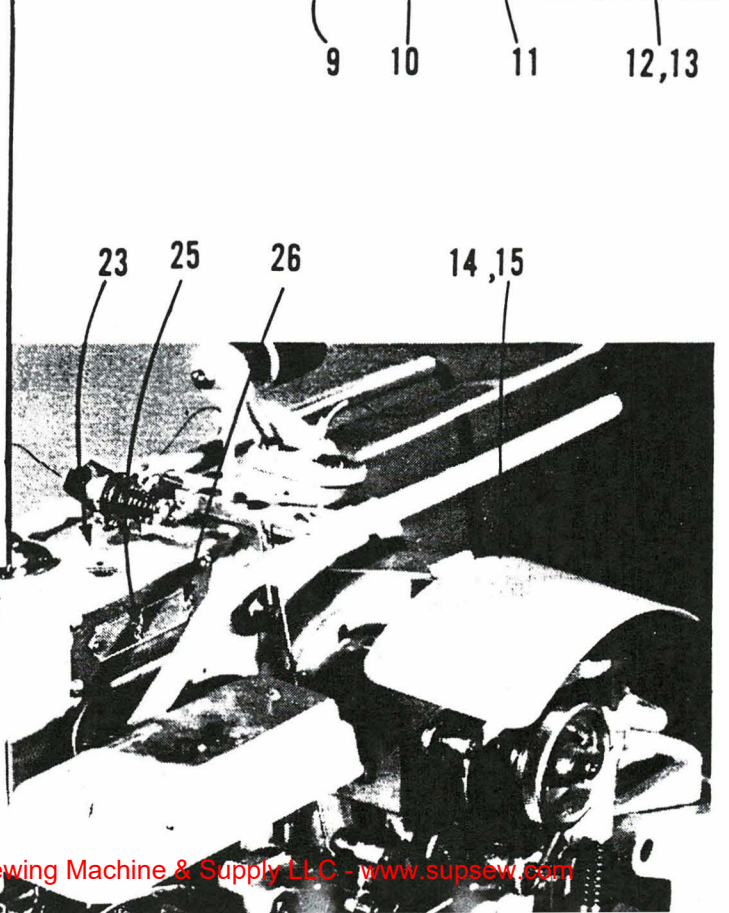

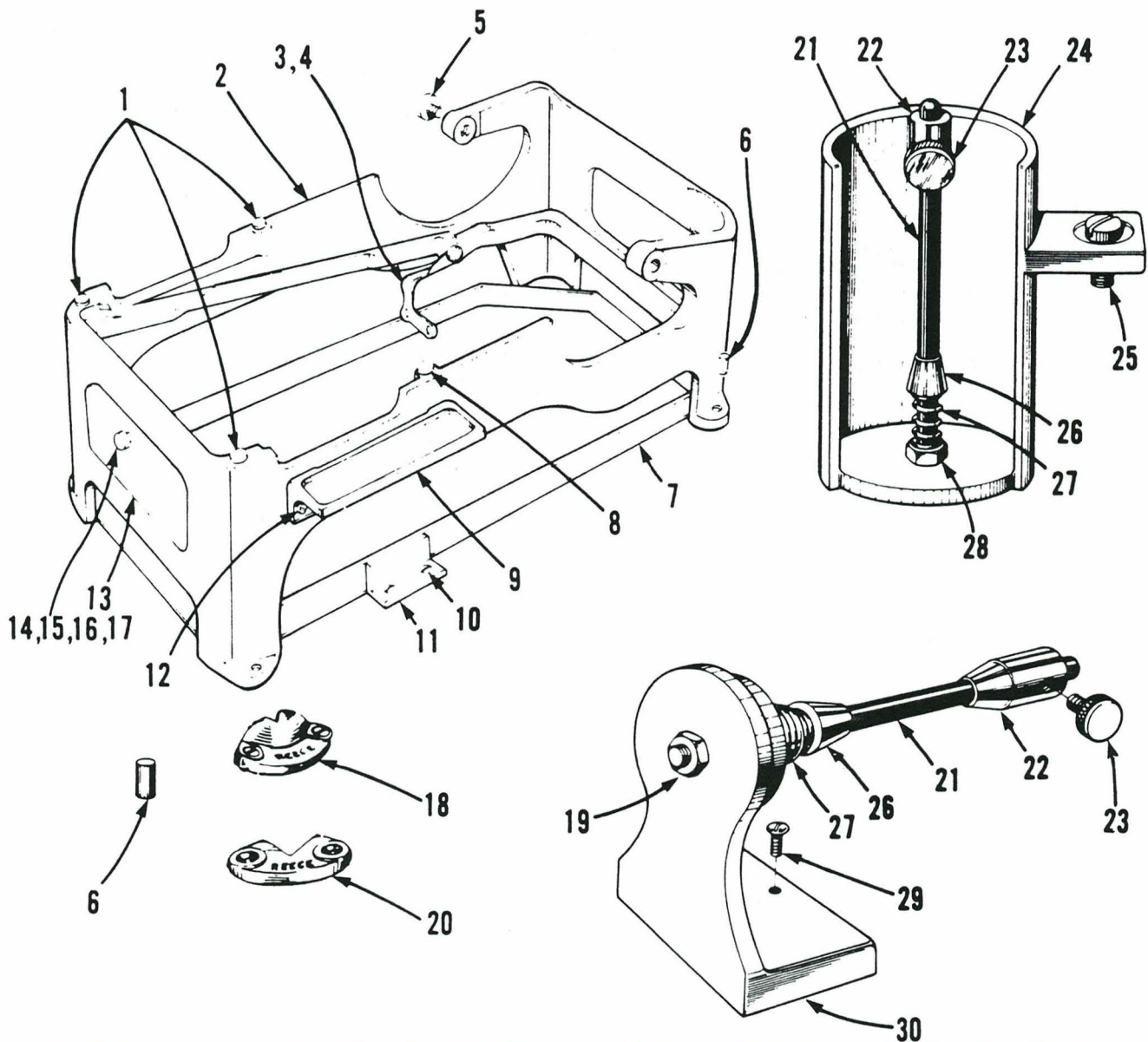

DET.	PART NUMBER	DESCRIPTION
1	10-5020	Cushion
2	10-5001	Stand
3	01-2078	Screw
4	10-5002	Thread Guide
5	10-2003	Pivot
6	10-5011	Insert
7	10-5004	Oil Pan
8	10-5020-0-250	Cushion
9	10-5003-1	Shelf
10	01-2340	Screw
11	10-5019	Bracket
12	01-2003	Screw
13	10-5005	Cover Assy.

14	10-5006-1	Clip
15	01-2050	Screw
16	01-4019	Washer
17	01-3040	Knob
18	10-5012	Base Plate
19	01-3009	Nut
20	10-5013	Base Plate
21	10-2057-1	Spindle
22	10-1402	Thimble
23	10-1401	Screw
24	10-2056	Spool Holder
25	01-2061	Screw
26	10-5009	Thimble
27	01-5051	Spring
28	01-3007	Nut
29	01-2083	Screw
30	10-5008-2	Bracket

# THREAD STAND

DET.	PART NUMBER	DESCRIPTION
1	01-3052	Nut
2	05-0004	Arm
3	01-3026	Nut
4	05-0005	Post
6	05-0006	Felt
7	05-0002	Shelf
8	01-2028	Screw
9	01-2190	Screw
10	05-0001-0-001	Base
11	01-2115	Screw
12	05-0003	Shelf

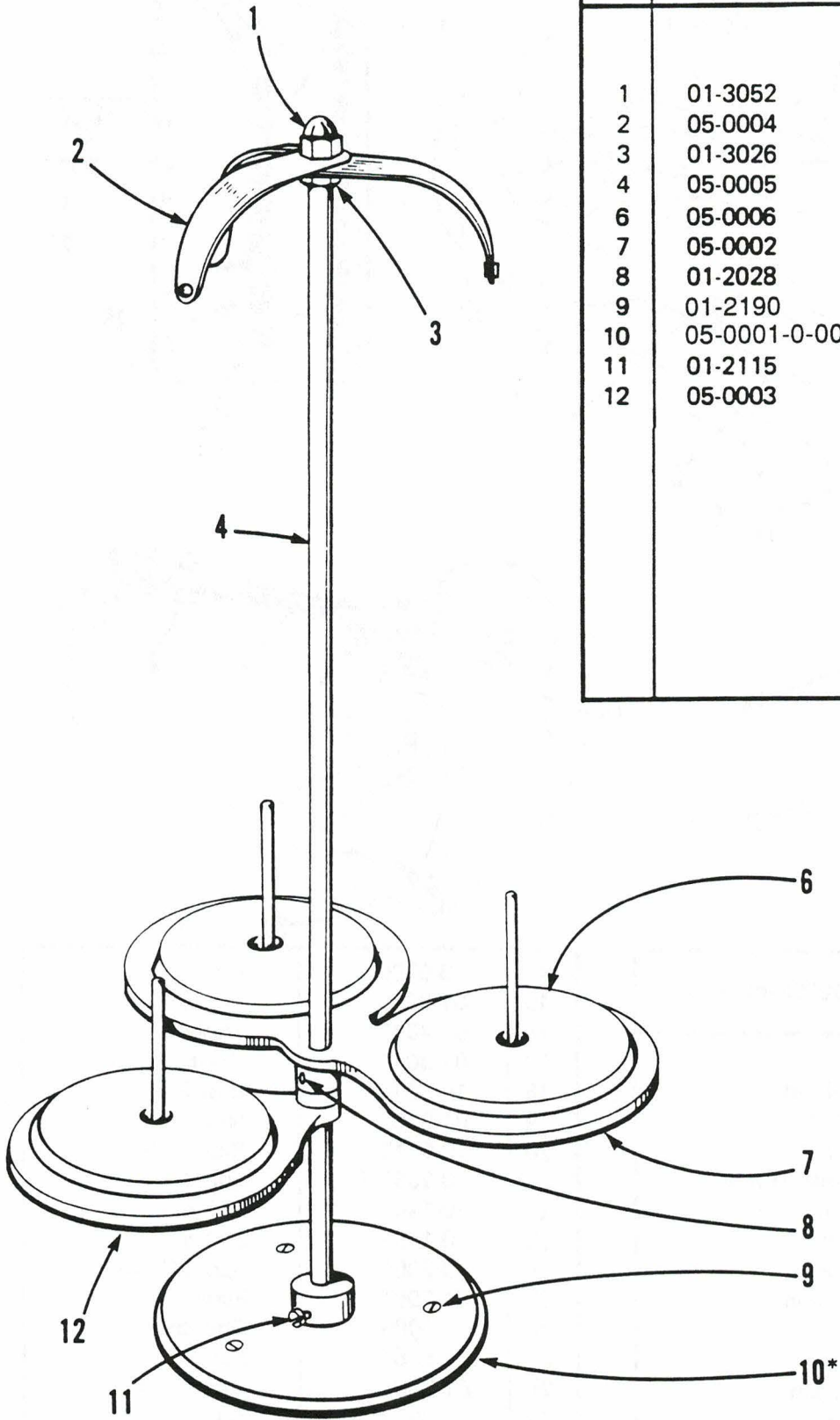

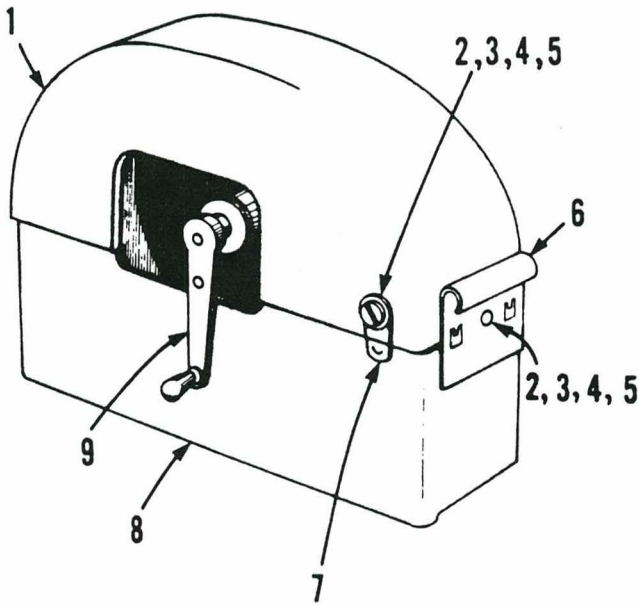

DET.	PART NUMBER	DESCRIPTION
1	10-1194-1-005	Top Left Cover
2	01-2247-0-003	Screw
3	01-4472	Washer
4	01-4407	Lock Washer
5	01-3402	Nut
6	10-1194-0-028	Latch
7	01-5123	Spring
8	10-1194-1-006	Left Bottom Cover
9	10-1194-0-014	Crank
10	10-1194-0-010	Hinge
11	01-2616	Screw
12	10-1194-0-016	Floating Shaft

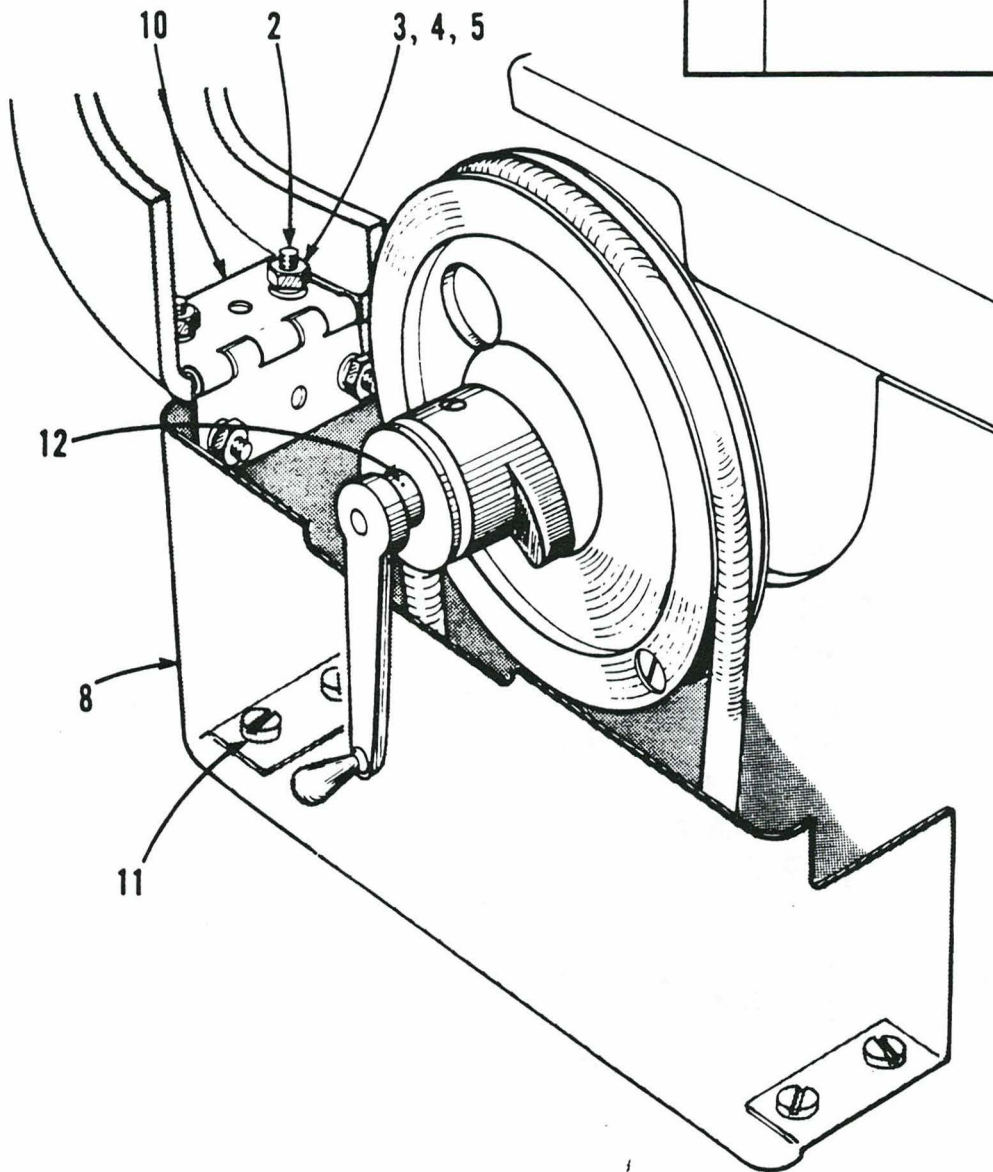

BELT GUARDS

DET.	PART NUMBER	DESCRIPTION
1	10-1194-0-019	Hinge Support
2	01-2247-0-003	Screw
3	01-4407	Lock Washer
4	01-4472	Washer
5	10-1194-0-008	Hinge
6	01-2247-0-001	Screw
7	01-3402	Nut
8	10-1194-0-020	Cover Support
9	10-1194-0-004	Right Top Cover
10	10-1194-0-003	Right Bottom Cover
11	01-2241-0-103	Screw
12	01-4406	Lock Washer
13	10-1194-1-012	Hinge
14	10-1194-0-009	Clip
15	01-4411	Washer
16	01-3401	Nut

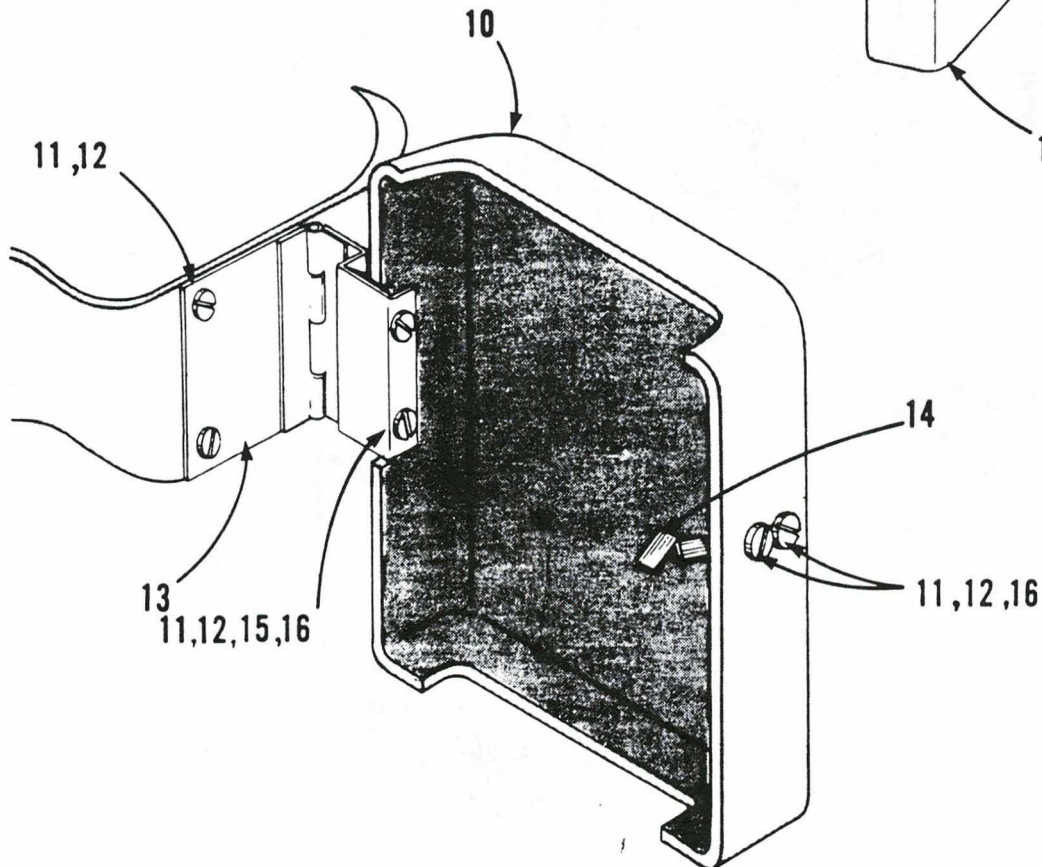
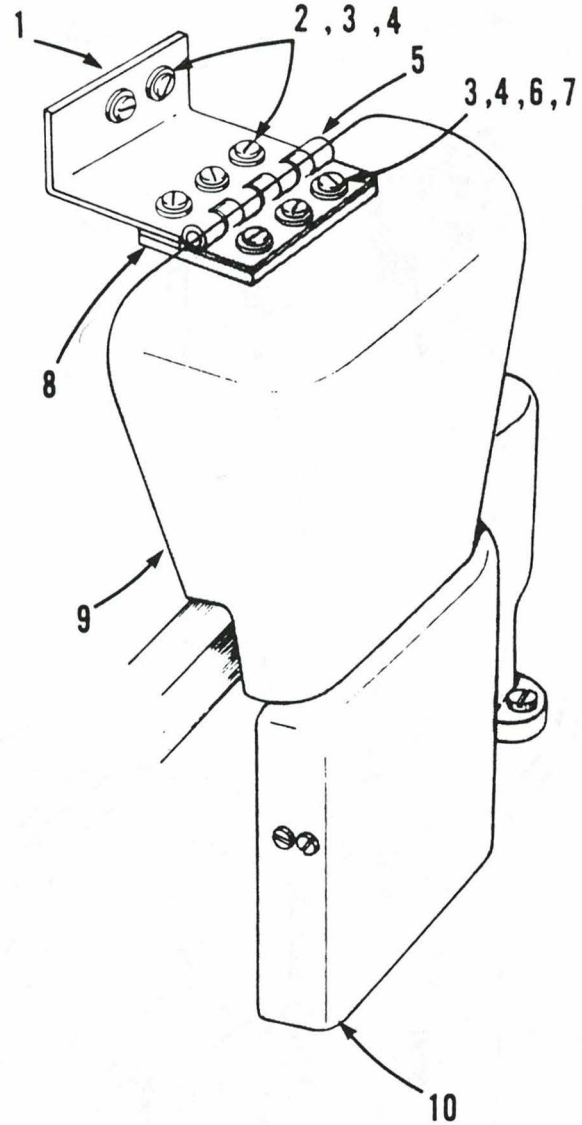

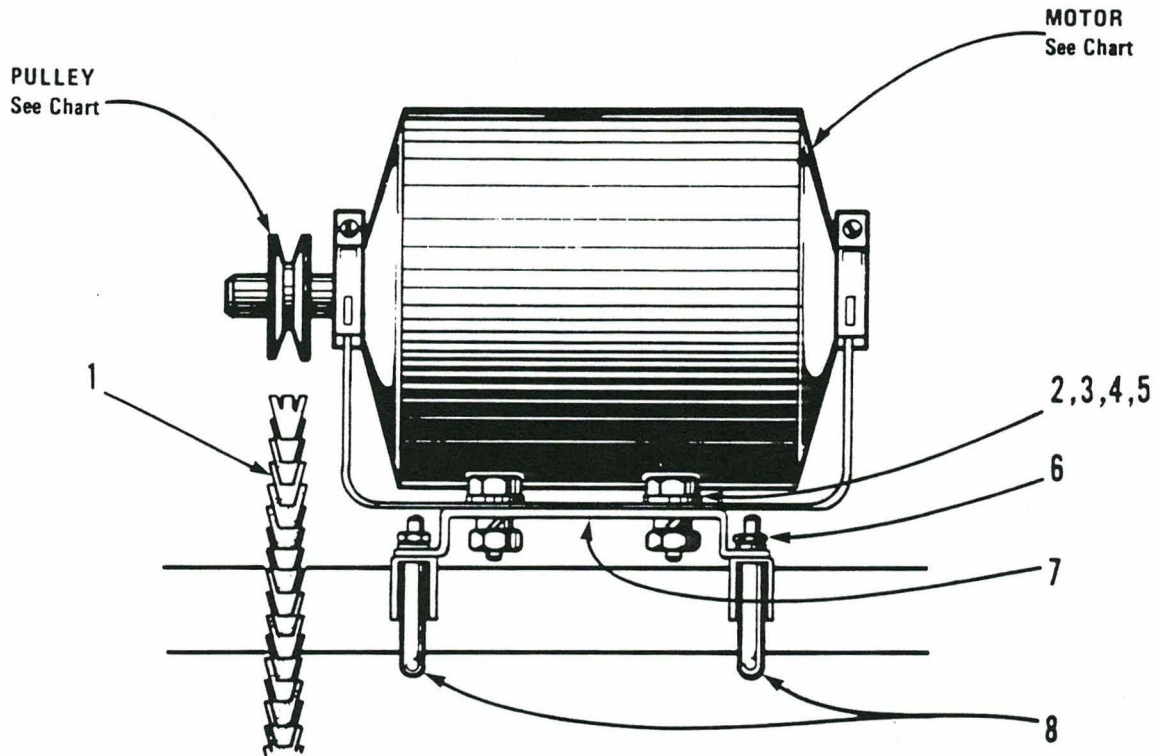

DET.	PART NUMBER	DESCRIPTION
1	04-0533-0-001	Belt
2	04-0044	Bolt
3	01-3549	Nut
4	01-4422	Lock Washer
5	01-4579-0-001	Washer
6	01-4581	Lock Washer
7	04-1517-0-001	Bracket
8	04-1524	U-Clamp

MOTOR PULLEYS	
04-0530-0-000	2.63" O.D. x .5515" Bore
04-0530-0-218	2.1" O.D. x 5/8" Bore
04-0530-0-258	2.5" O.D. x 5/8" Bore

MOTORS	
04-0002-0-071	1/3HP115/230 V 1PH 60Hz
04-0002-0-071	1/3HP115/230V 1PH 50 Hz
04-0002-0-016	1/2HP1PH 60HZ
04-0002-0-017	1/2HP208V 3PH 60Hz
04-0002-0-047	1/2HP230/460V 3PH 60Hz
04-0002-0-046	1/3HP208/460V 3PH 50/60

TRANSMITTER BASE & TREADLE

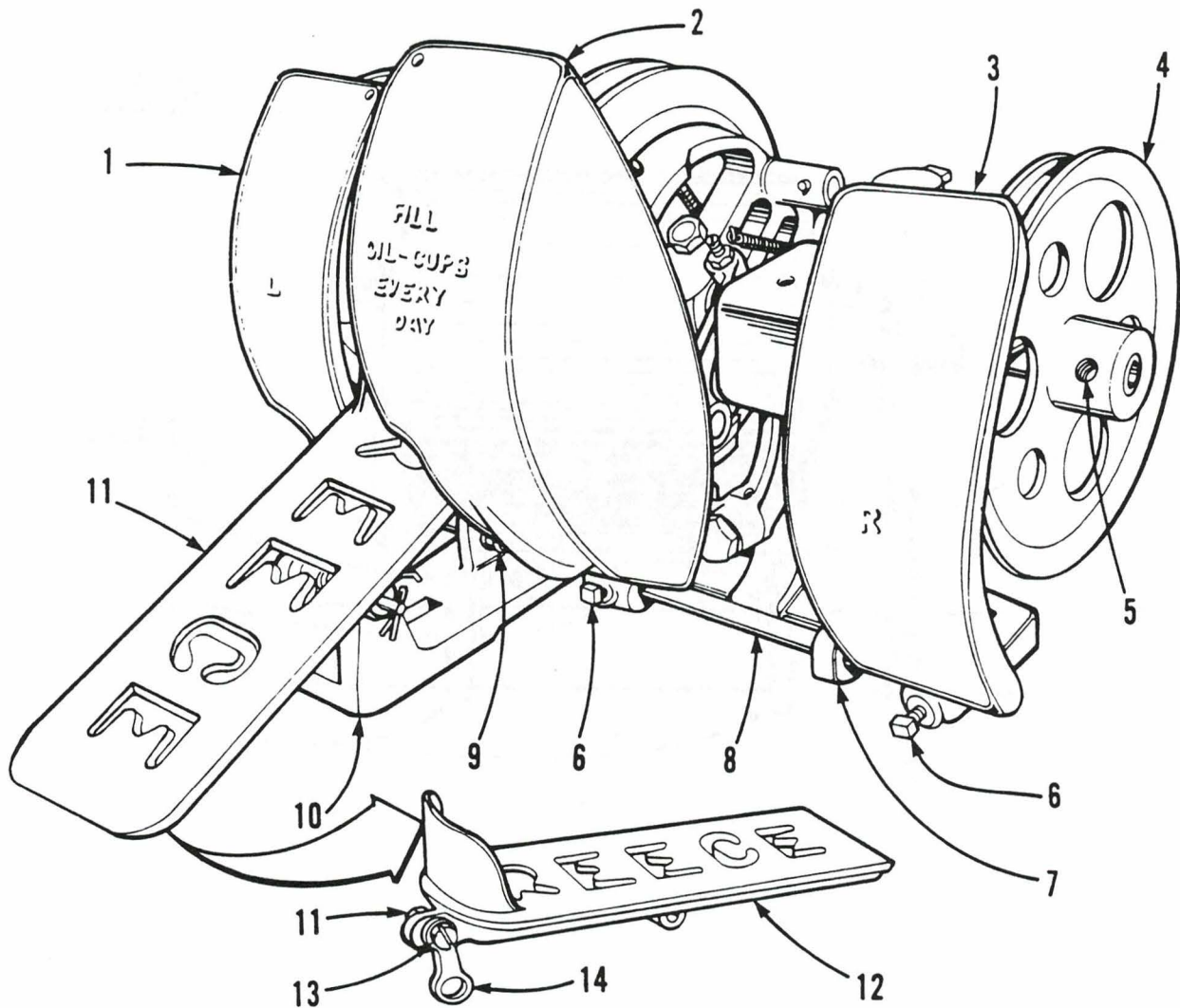

DET.	PART NUMBER	DESCRIPTION
1	04-0506	Left Guard
2	04-0507	Center Guard
3	04-0508	Right Guard
4	04-0515-0-030	Pulley 3" i.d.
	04-0515-0-045	Pulley 4½" i.d.
	04-0515-0-047	Pulley 4¾" i.d.
	04-0515-0-050	Pulley 5" i.d.
5	01-2399	Screw
6	04-0510	Guard Lock
7	04-0509	Rod
8	01-2014	Screw

9	01-5050	Spring
10	04-0501-0-050	Frame
11	01-3007	Nut
12	04-0502	Treadle
13	04-0504	Link
14	01-2046	Screw

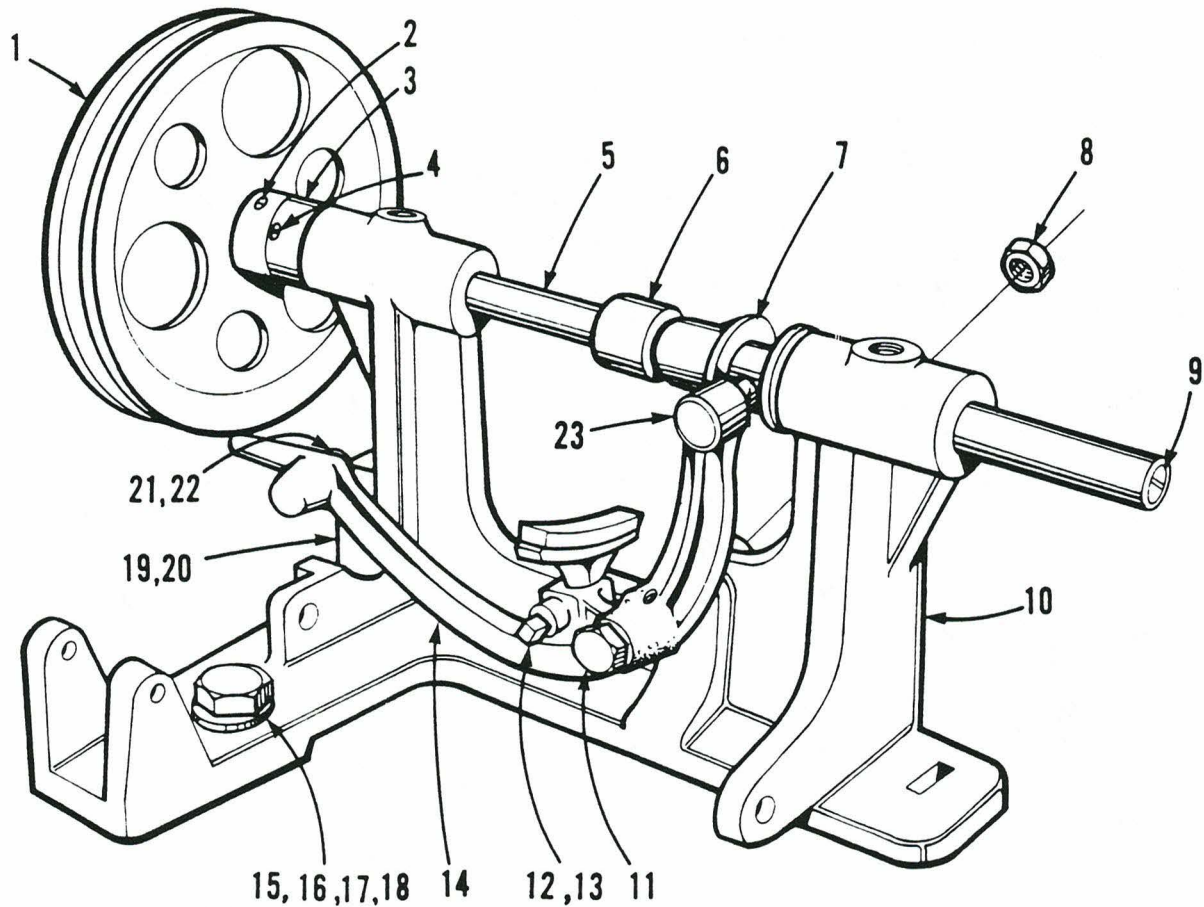

DET.	PART NUMBER	DESCRIPTION
1	04-0515-0-030	Grooved Pulley
2	01-2399	Set Screw
3	04-0523	Collar
4	01-2094	Screw
5	04-0524	Shaft
6	01-7019	Bushing
7	04-0522	Spool
8	01-3014	Nut
9	01-2095	Screw
10	04-0501	Frame
11	01-1076	Screw
12	04-0519	Plug
13	01-2014	Screw
14	04-0516-0-050	Clutch Lever Asm.

15	01-2110	Screw } Use for table mounting only	
16	01-3029		Nut
17	01-4043		Washer
18	01-4026		Washer
19	04-0518	Block	
20	01-2099	Screw	
21	04-0517	Plunger	
22	01-5058	Spring	
23	01-6132	Stud & Roll	

# TRANSMITTER PULLEYS

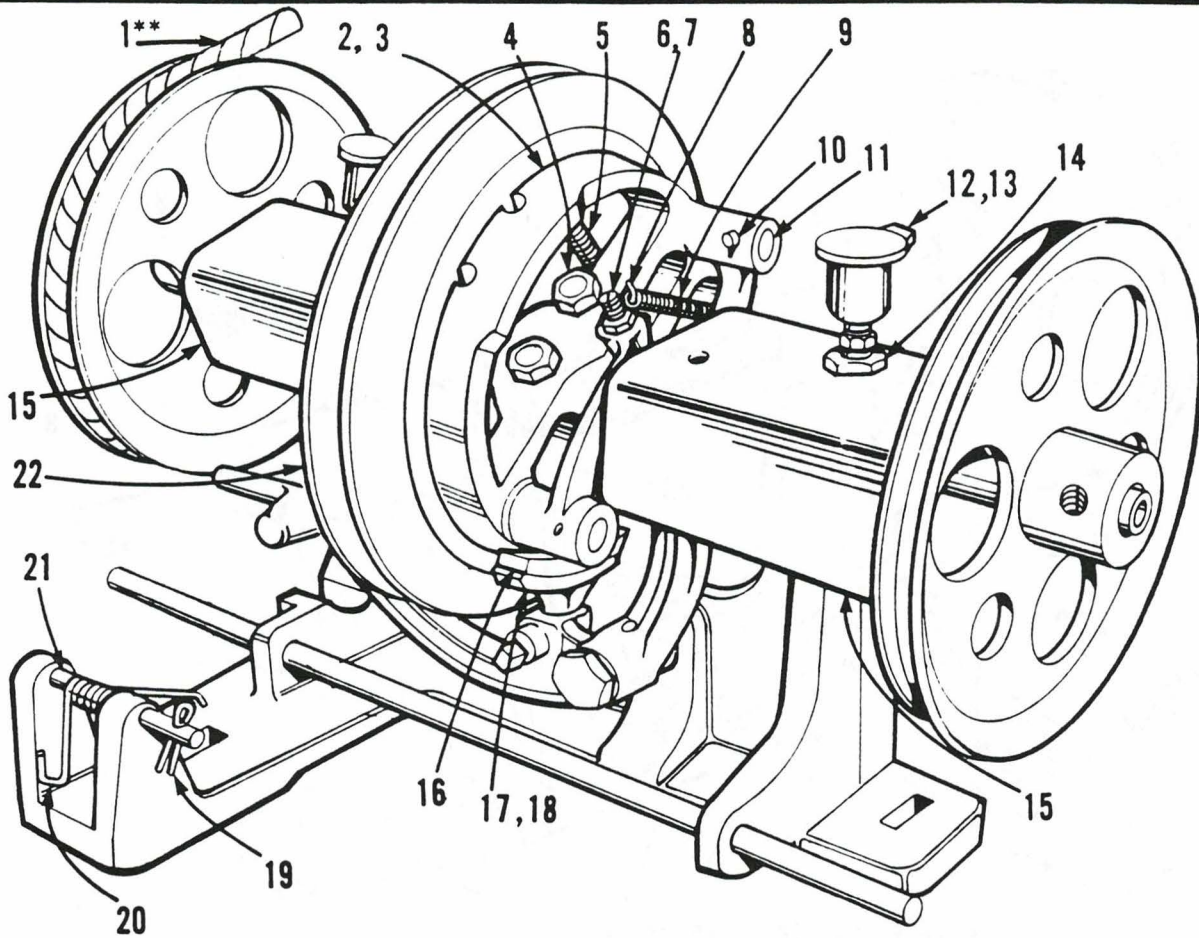

DET.	PART NUMBER	DESCRIPTION
1	04-0561-0-312**	5/16" Round Belt
2	04-0526-0-050	Clutch Shoe
3	04-0526-0-001	Body
4	01-2093	Screw
5	01-5049	Spring
6	01-2065	Screw
7	01-3011	Nut
8	01-6002	Anchor
9	01-5048	Spring
10	01-6027	Pin
11	04-0527-0-050	Clutch Expander
12	04-0513	Oil Cup
13	04-0514	Wick
14	01-3023	Lock Nut
15	04-0511	Guard
16	04-0520	Brake Lining
17	04-0521	Brake
18	01-6161	Rivet
19	01-6131	Cotter Pin
20	01-5145	Spring
21	01-6130	Pin

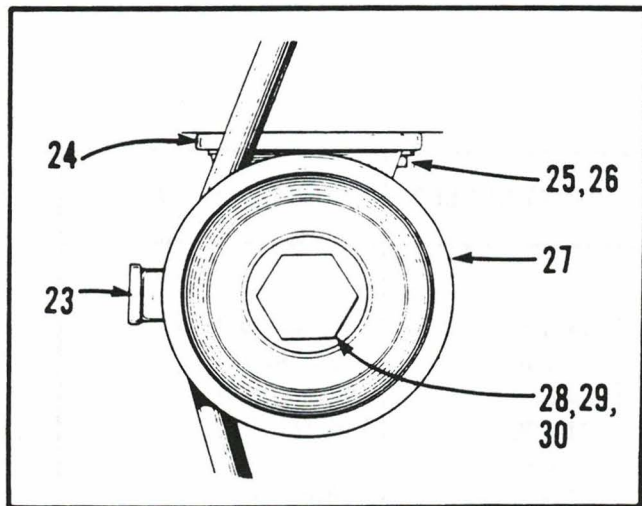

22	04-0525-0-065	Pulley
23	04-0150	Guard
24	04-0149	Bracket
25	01-2640	Screw
26	01-4578	Washer
27	04-0148	Pulley
28	01-1448	Pivot Screw
29	01-3008	Nut
30	01-7463	Bushing
31	05-0376-0-015	Belt HOOK

\*\*Furnished in multiples of one foot or 100 foot spools.

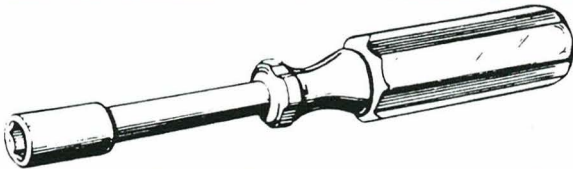

1	03-0007 03-0033	Socket Wrench 1/4" Socket Wrench 5/16"
---	--------------------	---



2	03-0038	Screwdriver Double ended Blade (included with #2 or can be ordered separately.)
3	03-0053	



4	03-0188 03-0189 03-0024 03-0278	Screwdriver 3/16" - 10" Screwdriver 1/4" - 8" Screwdriver 3" Blade Screwdriver 2" Blade
---	--	--



5	03-0045	Pin Wrench
---	---------	------------

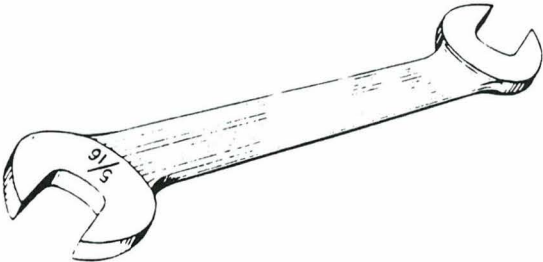

6	03-0018	3/8" - 5/16" Wrench
---	---------	---------------------



7	03-0019	Wrench 1/4"
---	---------	-------------

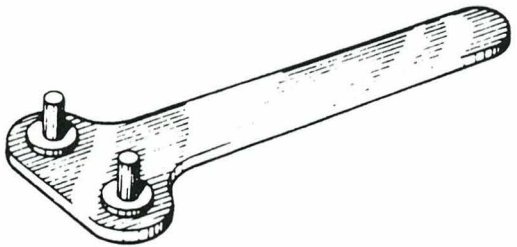

8	03-0011	Spanner Wrench
---	---------	----------------



9	03-0010 03-0048-1	Sq. Socket Wrench 5/16" Sq. Socket Wrench 7/16"
---	----------------------	--



10	03-0013	Tweezers
----	---------	----------



11	03-0279	Gage
----	---------	------



12	03-0032-0-003 03-0032-0-004 03-0032-0-005 03-0032-0-612*	Emery Cord #3 Fine Emery Cord #4 Med. Emery Cord #5 Coarse Emery Cord #612
----	---	---



13	03-0020	Threading Wire
----	---------	----------------

\*Extra Fine (for loopers)

Faint, illegible text at the top of the page, possibly a title or header.

PART NUMBER	PAGE	DET.	PART NUMBER	PAGE	DET.	PART NUMBER	PAGE	DET.
<b>01-1000</b>			01-1132	13	7	01-2004	51	39
01-1006	27	27	01-1132	67	16	01-2004	60	13
01-1006	28	10	01-1137	3	22	01-2004	85	18
01-1020-1	2	15	01-1137	57	7	01-2006	16	32
01-1020-1	4	8	01-1137	78	6	01-2006	55	14
01-1021	4	4						
			01-1137	84	6	01-2006	75	12
01-1023	32	8	01-1427	47	7	01-2007	24	25
01-1028	13	58	01-1432	16	11	01-2007	73	18
01-1031	39	7	01-1435	83	8	01-2008	13	16
01-1031	50	18	01-1441	72	2	01-2008	21	22
01-1031	57	48						
			01-1442	72	21	01-2008	47	28
01-1057	81	20	01-1445	59	23	01-2008	58	18
01-1061	66	6	01-1445	69	9	01-2011	21	1
01-1061	73	3	01-1445	75	20	01-2012	24	15
01-1061	82	6	01-1446	59	29	01-2013	32	20
01-1072	60	20						
			01-1446	69	7	01-2013	47	46
01-1076	5	39	01-1446	75	16	01-2013	27	21
01-1076	95	11	01-1447	16	7	01-2014	29	4
01-1095	9	29	01-1448	96	28	01-2014	66	8
01-1100	50	5	01-1449	72	24	01-2014	94	8
01-1103	82	14						
			01-1456	50	23	01-2014	95	13
01-1105	78	14	01-1457	51	47	01-2015	3	18
01-1112	23	19	01-1461	64	5	01-2015	78	10
01-1112	79	14	01-1491	47	57	01-2015	84	21
01-1112	82	2				01-2016	14	6
01-1112	83	14	<b>01-2000</b>			01-2016	15	2
						01-2016	29	9
01-1113	23	32	01-2001	23	27	01-2016	41	13
01-1113	68	11	01-2001	28	7	01-2016	69	23
01-1113	79	7	01-2001	33	5	01-2017	10	3
01-1113	83	16	01-2001	54	11	01-2017	41	4
01-1114	23	23	01-2001	60	26	01-2017	73	5
						01-2019	10	8
01-1114	54	12	01-2001	68	21	01-2020	9	23
01-1114	79	21	01-2001	79	11	01-2020	47	23
01-1115	81	28	01-2001	83	12	01-2020	50	24
01-1116	80	20	01-2002	13	50	01-2020	73	31
01-1118	81	5	01-2002	68	22	01-2020	81	25
						01-2022	13	22
01-1120	44	19	01-2002	83	13	01-2024	7	14
01-1120	48	11	01-2003	89	12			
01-1120	85	15	01-2004	8	9	01-2024	11	6
01-1130	33	22	01-2004	44	21	01-2024	27	23
01-1131	33	10	01-2004	48	13	01-2024	31	32
						01-2024	47	58
						01-2024	61	22

## PARTS INDEX

PART NUMBER	PAGE	DET.	PART NUMBER	PAGE	DET.	PART NUMBER	PAGE	DET.
01-2024	68	29	01-2042	40	18	01-2054	88	15
01-2024	73	34	01-2043	16	9	01-2056	27	36
01-2025	50	1	01-2044	5	19	01-2056	58	9
01-2027	8	20	01-2045	5	14	01-2056	72	14
01-2027	44	12	01-2045	44	16	01-2059	27	32
01-2027	48	4	01-2045	47	47	01-2059	39	3
01-2027	66	15	01-2045	48	8	01-2059	60	8
01-2027	85	5	01-2045	67	13	01-2059	61	10
01-2028	13	19	01-2045	85	13	01-2059	81	1
01-2028	29	8	01-2046	5	9	01-2061	9	8
01-2028	66	25	01-2046	94	14	01-2061	13	44
01-2028	67	26	01-2047	5	11	01-2061	23	15
01-2028	79	30	01-2048	5	4	01-2061	89	25
01-2028	88	21	01-2050	42	10	01-2063	24	14
01-2028	90	8	01-2050	47	1	01-2065	96	6
01-2030	5	38	01-2050	61	13	01-2066	7	22
01-2030	13	17	01-2050	67	17	01-2067	8	21
01-2030	67	24	01-2050	69	10	01-2068-1	40	16
01-2031	16	22	01-2050	73	29	01-2069	5	13
01-2032-1	6	20	01-2050	74	7	01-2070	80	19
01-2033	8	18	01-2050	75	22	01-2071	6	3
01-2034	33	9	01-2050	81	12	01-2073	28	12
01-2035	6	15	01-2050	82	11	01-2073	47	11
01-2035	11	5	01-2050	89	15	01-2073	58	8
01-2037	13	49	01-2050	89	15	01-2073	73	24
01-2037	81	18	01-2050-1-100	86	5	01-2074	47	29
01-2038	32	25	01-2051	2	4	01-2074	57	35
01-2038	39	9	01-2051	64	20	01-2074	73	10
01-2038	60	23	01-2051	72	17	01-2074	7	8
01-2038	73	9	01-2051	84	11	01-2075	7	8
01-2039	23	20	01-2052	2	6	01-2075	13	53
01-2039	32	24	01-2052	64	18	01-2075	19	23
01-2039	33	2	01-2052	84	16	01-2075	57	1
01-2039	39	7	01-2053	2	14	01-2075	58	16
01-2039	54	20	01-2053	28	27	01-2075	60	22
01-2039	60	25	01-2053	55	9	01-2075	64	12
01-2039	66	23	01-2053	57	27	01-2076	57	54
01-2039	73	8	01-2053	64	10	01-2077	31	12
01-2039	79	20	01-2053	72	11	01-2077	61	18
01-2041	6	7	01-2054	46	33	01-2078	29	1
01-2041	13	34	01-2054	57	9	01-2078	47	49
01-2041	25	5	01-2054	61	7	01-2078	89	3
01-2041	40	11	01-2054	62	6	01-2079	10	19
01-2041	82	9	01-2054	72	12	01-2079	16	17
01-2042	9	32	01-2054	80	1	01-2079	19	19
						01-2079	44	25

PART NUMBER	PAGE	DET.	PART NUMBER	PAGE	DET.	PART NUMBER	PAGE	DET.
01-2079	48	17	01-2131	31	6	01-2347	61	4
01-2079	62	7	01-2131	80	12	01-2347	85	24
01-2079	68	24	01-2131	86	12	01-2356	43	3
01-2079	73	22	01-2136	58	4	01-2356	47	15
01-2079	75	26	01-2136	59	8	01-2361	28	18
01-2079	85	10	01-2143	40	3	01-2361	31	38
01-2081	27	24	01-2144	31	17	01-2361	68	37
01-2081	28	15	01-2146	13	31	01-2361	79	25
01-2081	31	36	01-2167	47	55	01-2362	23	25
01-2081	46	40	01-2170	74	5	01-2362	54	22
01-2081	60	6	01-2171	31	15	01-2365	81	7
01-2081	68	41	01-2175	31	8	01-2371	80	7
01-2083	89	29	01-2175	80	10	01-2386	50	9
01-2084	7	13	01-2190	90	9	01-2387	78	1
01-2085	15	13	01-2193	19	31	01-2390	13	37
01-2085	69	19	01-2193	47	59	01-2391	13	29
01-2087	41	11	01-2194	31	27	01-2392	14	7
01-2087	42	19	01-2194	61	16	01-2398	67	7
01-2087	73	17	01-2194	68	8	01-2399	94	5
01-2088	16	28	01-2241-0-103	92	11	01-2399	95	2
01-2093	88	3	01-2247-0-001	92	6	01-2410	3	34
01-2093	96	4	01-2247-0-003	91	2	01-2419	19	9
01-2094	95	4	01-2247-0-003	92	2	01-2500	62	2
01-2095	95	9	01-2248	19	21	01-2509	23	3
01-2099	95	20	01-2249	12	1	01-2567	44	10
01-2100	21	24	01-2312	3	32	01-2567	48	2
01-2102	33	23	01-2312	66	2	01-2567	85	3
01-2102	39	8	01-2318	28	22	01-2568	13	40
01-2102	60	29	01-2318	31	42	01-2568	88	8
01-2104	57	37	01-2318	58	22	01-2571	10	20
01-2110	95	15	01-2318	68	39	01-2586	72	7
01-2111	2	11	01-2320	47	34	01-2587	64	6
01-2111	23	12	01-2324	15	8	01-2616	91	11
01-2111	64	15	01-2324	69	3	01-2640	96	25
01-2111	72	26	01-2328	5	5	01-2645	50	19
01-2111	78	9	01-2329	9	36	01-2667	58	39
01-2111	84	3	01-2329	23	28	01-2979	62	10
01-2115	51	36	01-2340	89	10			
01-2115	66	24	01-2343	88	11			
01-2115	90	11	01-2344	13	41	<b>01-3000</b>		
01-2121	40	15	01-2344	51	45	01-3001	2	1
01-2124	59	20	01-2347	5	34	01-3001	5	20
01-2130	13	35	01-2347	44	4	01-3001	13	45
01-2130	80	21	01-2347	48	22	01-3001	23	16
01-2131	19	2				01-3001	27	9

## PARTS INDEX

PART NUMBER	PAGE	DET.	PART NUMBER	PAGE	DET.	PART NUMBER	PAGE	DET.
01-3001	32	13	01-3012	21	31	01-3026	90	3
01-3001	47	35	01-3013	5	16	01-3028	21	28
01-3001	50	22	01-3013	14	4	01-3029	95	16
01-3001	57	12	01-3013	15	10	01-3030	44	11
01-3001	60	11				01-3040	88	20
			01-3013	69	16			
01-3001	64	2	01-3014	5	40	01-3040	89	17
01-3001	67	6	01-3014	95	8	01-3042	13	8
01-3001	72	22	01-3015	8	22	01-3042	67	20
01-3001	84	10				01-3052	90	1
01-3004	19	15	01-3016	3	23	01-3059	8	13
			01-3016	5	15			
01-3005	7	4	01-3016	16	18	01-3065	44	17
01-3005	8	17	01-3016	31	26	01-3065	47	42
01-3005	9	4	01-3016	57	52	01-3065	48	9
01-3005	10	1				01-3065	85	14
01-3005	13	28	01-3016	61	26	01-3066	64	4
			01-3016	67	8			
01-3005	25	11	01-3016	68	5	01-3067	39	4
01-3005	27	3	01-3016	78	7	01-3067	47	62
01-3005	31	13	01-3016	84	7	01-3401	92	16
01-3005	40	10				01-3402	91	5
01-3005	42	13	01-3017	5	12	01-3402	92	7
			01-3018	29	21			
01-3005	51	28	01-3019	13	11	01-3422	54	1
01-3005	61	19	01-3019	67	28	01-3436	9	20
01-3005	80	23	01-3020	24	22	01-3439	72	25
01-3006	32	18				01-3491	59	15
01-3007	5	3	01-3020	59	30	01-3512	19	28
			01-3020	69	13			
01-3007	6	18	01-3020	75	24	01-3549	93	3
01-3007	8	5	01-3021	57	33			
01-3007	9	9	01-3021	58	17			
01-3007	10	16				<b>01-4000</b>		
01-3007	23	7	01-3021	64	3			
			01-3021	66	5	01-4001	8	10
01-3007	42	9	01-3021	73	2	01-4001	32	14
01-3007	81	10	01-3021	82	7	01-4001	40	12
01-3007	86	4	01-3022	41	9	01-4002	10	5
01-3007	89	28				01-4003	7	15
01-3007	94	11	01-3023	96	14			
			01-3025	23	1	01-4003	33	21
01-3008	96	29	01-3025	25	7	01-4003	66	3
01-3009	12	3	01-3025	28	19	01-4004	9	14
01-3009	47	60	01-3025	31	39	01-4005	5	17
01-3009	67	15						
01-3009	89	19	01-3025	68	36	01-4005	14	3
			01-3025	72	6	01-4005	15	9
01-3010	24	29	01-3025	73	19	01-4005	69	15
01-3011	7	23	01-3026	59	26	01-4006	5	37
01-3011	39	9	01-3026	75	33			
01-3011	96	7						
01-3012	7	2						

PART NUMBER	PAGE	DET.	PART NUMBER	PAGE	DET.	PART NUMBER	PAGE	DET.
01-4006	7	11	01-4034-0-003	21	14	01-4422	93	4
01-4006	15	14	01-4034-0-003	78	21	01-4472	16	25
01-4006	30	2	01-4034-0-004	21	14	01-4472	91	3
01-4006	51	31	01-4034-0-005	21	14	01-4472	92	4
01-4006	69	20	01-4038	3	24	01-4501	51	34
01-4006	73	6	01-4038	57	53	01-4502	51	35
01-4007	11	15	01-4038	78	8	01-4503	16	21
01-4008	11	16	01-4038	84	8	01-4503	29	15
01-4009	11	14	01-4039	47	43	01-4522	50	2
01-4010	24	20	01-4042	13	27	01-4578	96	26
01-4011	9	5	01-4042	47	30	01-4579-0-001	93	5
01-4011	39	10	01-4042	60	12	01-4581	93	6
01-4011	73	11	01-4042	73	35			
01-4012	27	7	01-4042	81	16	<b>01-5000</b>		
01-4012	62	8	01-4043	95	17	01-5001	54	18
01-4013	28	9	01-4046	16	29	01-5002	23	31
01-4013	59	21	01-4052	13	36	01-5002	54	14
01-4013	61	11	01-4061	5	35	01-5002	68	20
01-4015	28	23	01-4061	44	5	01-5002	79	19
01-4015	31	43	01-4061	48	23	01-5002	83	21
01-4015	58	23	01-4061	61	5	01-5003	21	20
01-4015	68	40	01-4061	62	3	01-5004	27	47
01-4018	8	19	01-4061	85	25	01-5004	47	44
01-4018	29	2	01-4063	13	9	01-5005-0-001	24	3
01-4019	10	21	01-4063	50	15	01-5006-0-001	32	3
01-4019	13	21	01-4063	67	19	01-5007	10	6
01-4019	89	16	01-4065	51	27	01-5009	10	11
01-4020	41	10	01-4067	4	2	01-5010	9	18
01-4023	11	12	01-4067	81	2	01-5011	9	25
01-4024	42	8	01-4074	23	6	01-5013	5	24
01-4024	47	24	01-4074	79	27	01-5013	9	6
01-4024	50	25	01-4076	81	8	01-5013	75	18
01-4024	73	32	01-4081-0-005	21	17	01-5014	9	27
01-4024	81	11	01-4081-0-006	21	17	01-5015	5	30
01-4024	86	3	01-4081-0-007	21	17	01-5017	11	22
01-4026	95	18	01-4081-0-008	21	17	01-5018	13	48
01-4027	66	13	01-4081-0-009	21	17	01-5018	47	6
01-4029	33	19	01-4081-0-010	21	17	01-5019	6	4
01-4029	51	38	01-4081-0-011	21	17	01-5019	44	9
01-4034	66	11	01-4081-0-012	21	17	01-5019	48	1
01-4034-0-001	21	14	01-4083	83	3	01-5019	85	4
01-4034-0-001	78	21	01-4406	92	12	01-5020	6	10
01-4034-0-002	21	14	01-4407	91	4	01-5020	67	5
01-4034-0-002	78	21	01-4407	92	3	01-5022	3	30
01-4034-0-003	9	19	01-4411	92	15			

## PARTS INDEX

PART NUMBER	PAGE	DET.	PART NUMBER	PAGE	DET.	PART NUMBER	PAGE	DET.	
01-5023	4	11	01-5076	75	6	<b>01-6000</b>			
01-5024	28	11	01-5077	72	5				
01-5025	28	11	01-5088	7	19				
01-5026	27	31	01-5098	54	3				
01-5027	27	10	01-5102	72	29				
01-5028	27	15	01-5123	91	7		01-6001	58	24
01-5028	43	9	01-5126	44	20		01-6002	27	34
01-5028	47	22	01-5126	48	12		01-6002	28	16
01-5029	33	12	01-5126	85	16		01-6002	31	35
01-5033	57	44	01-5145	96	20		01-6002	57	50
01-5034	57	26	01-5163	23	22		01-6002	58	26
01-5037	57	51	01-5163	54	13		01-6002	60	7
01-5038	31	14	01-5163	79	22		01-6002	81	6
01-5038	61	20	01-5164	81	17		01-6002	96	8
01-5038	68	28	01-5166	33	8		01-6003	26	38
01-5039	39	5	01-5167	19	32		01-6005	9	16
01-5039	60	17	01-5167	47	9		01-6005	33	16
01-5040	81	26	01-5172	14	16		01-6006	5	25
01-5041	28	17	01-5173	33	20		01-6006	6	5
01-5041	31	37	01-5429	50	20		01-6006	16	4
01-5041	68	3	01-5433	31	19		01-6006	32	5
01-5041	73	21	01-5434	43	4		01-6007	5	23
01-5042	60	4	01-5434	47	17		01-6009	55	13
01-5043	58	12	01-5447	13	38		01-6009	75	10
01-5044	58	21	01-5448	13	25		01-6010	58	25
01-5045	55	5	01-5450	10	14	01-6010	68	34	
01-5048	50	4	01-5457	72	8	01-6011	6	9	
01-5048	96	9	01-5459	69	12	01-6011	39	8	
01-5049	96	5	01-5459	75	21	01-6011	60	16	
01-5050	94	9	01-5460	59	25	01-6013	39	6	
01-5051	47	50	01-5460	69	11	01-6013	42	15	
01-5051	89	27	01-5460	75	23	01-6013	60	2	
01-5052	46	36	01-5473	50	7	01-6014	5	29	
01-5053	42	16	01-5475	51	42	01-6014	9	26	
01-5054	16	3	01-5522	59	16	01-6014	24	5	
01-5055	8	7	01-5524	59	24	01-6014	81	27	
01-5058	95	22	01-5603	23	37	01-6014	88	1	
01-5059	58	32	01-5603	68	16	01-6015	31	46	
01-5061	32	15	01-5603	79	2	01-6015	57	43	
01-5062	57	31	01-5603	79	15	01-6017	57	47	
01-5062	88	17	01-5603	83	2	01-6018	27	8	
01-5064	57	39	01-5603	83	26	01-6018	58	28	
01-5065	57	40				01-6020-1	7	18	
01-5070	39	3				01-6021	9	31	
01-5070	47	63				01-6021	39	4	

PART NUMBER	PAGE	DET.	PART NUMBER	PAGE	DET.	PART NUMBER	PAGE	DET.
01-6023	13	46	01-6600	10	18	<b>03-0000</b>		
01-6025	8	6	01-6834	19	26	03-0007	97	1
01-6026	66	27	01-6837	32	9	03-0010	97	9
01-6027	96	10	01-6837-0-001	32	9	03-0011	97	8
01-6028	11	9	01-6837-0-001	75	35			
						03-0013	97	10
01-6031	16	30	01-6839	4	10	03-0018	97	6
01-6034	39	5	01-6983-0-001	32	23	03-0019	97	7
01-6034	60	30				03-0020	97	13
01-6036	33	24	<b>01-7000</b>			03-0024	97	4
01-6040	9	33						
			01-7002	9	10	03-0032-0-003	97	12
01-6042	79	24	01-7004	14	1	03-0032-0-004	97	12
01-6075	4	6	01-7004	15	5	03-0032-0-005	97	12
01-6099	33	13	01-7004	41	7	03-0032-0-612	97	12
01-6130	96	21	01-7004	69	4	03-0033	97	1
01-6131	96	19						
			01-7015	19	12	03-0038	97	2
01-6132	95	23	01-7019	95	6	03-0045	97	5
01-6161	96	18	01-7022	27	35	03-0048-1	97	9
01-6167	44	18	01-7023	14	12	03-0053	97	3
01-6167	48	10	01-7023	62	12	03-0188	97	4
01-6167	85	12	01-7023	85	21	03-0189	97	4
01-6328	33	15	01-7035	81	23	03-0278	97	4
01-6334	23	26	01-7038	13	18	03-0279	79	11
01-6334	54	24	01-7038	67	25	03-5238	57	29
01-6337	79	8	01-7041	23	8	03-5239	57	29
01-6345	8	16	01-7041	24	1	<b>04-0000</b>		
01-6350	9	13	01-7043	14	14	04-0044	93	2
01-6352	72	4	01-7433	47	5	04-0148	96	27
01-6365	82	3	01-7435-1	31	29	04-0149	96	24
01-6367	83	25	01-7435-1	61	17	04-0150	96	23
						04-0166	51	37
01-6368	19	27	01-7435-1	68	9			
01-6368	31	21	01-7436	40	9	04-0501	95	10
01-6368	40	8	01-7437	40	14	04-0518	95	19
01-6368	83	24	01-7438	31	31	01-2099	95	20
01-6369	83	9	01-7438	61	23			
01-6404	19	25	01-7439	68	32	04-0501-0-050	94	10
01-6428	13	39	01-7463	96	30	04-0502	94	12
01-6499	23	4	01-7464	67	30	04-0504	94	13
01-6527	73	20	01-7464	78	24	04-0506	94	1
01-6528	31	20	01-7468	10	25	04-0507	94	2
01-6529	40	7	<b>01-8000</b>					
01-6560	32	2						
01-6571	72	9	01-8002	13	24			
01-6577	72	3						
01-6580	51	33						



PART NUMBER	PAGE	DET.	PART NUMBER	PAGE	DET.	PART NUMBER	PAGE	DET.
10-1027-1-050	19	10	10-1062	24	10	10-1091-0-000	25	12
10-1027-1			10-1063	24	7	10-1093-1	13	23
01-2356	19	9	10-1065	21	23	01-2249	12	1
10-1028-2	19	13	10-1066-2	24	9	10-1094-3-850	10	10
10-1029-1	19	30	10-1068-1-050	32	6	10-1094-3-801		
10-1029	46	10	10-1163	32	7	10-1095-3	10	24
10-1030-0-017	19	29	01-6024	32	9	10-1096	10	9
10-1030-0-017	47	8	10-1069-0-100	80	4	01-2019	10	8
10-1031	21	3	10-1069-0-104	86	11	01-5009	10	11
10-1031	66	21	10-1077	68	12	10-1095-3	10	24
10-1032	18	3	10-1071-1-023	32	19	10-1096	10	9
10-1032-3-300	66	4	10-1071-2	32	19	10-1097-1	10	23
10-1032-3-300	73	1	10-1072	32	1	10-1098-1-050	9	17
10-1032-3-300	82	5	10-1073-1	32	21	10-1102-1	9	12
10-1033-0-350	66	12	10-1074	32	16	01-3007	9	9
10-1033-1	21	15	10-1074-0-250	32	17	01-4004	9	14
10-1034	21	12	10-1075-0-400	66	9	01-6350	9	13
10-1034	66	7	10-1075-0-400	74	2	01-7002	9	10
10-1036-1	21	26	10-1075-1	29	5	10-1099	9	38
10-1037	21	9	10-1076	21	4	10-1100	9	15
10-1038-2	21	8	10-1077	23	33	10-1101	9	24
10-1039	21	7	10-1077	26	19	10-1102-1	9	12
10-1040	21	6	10-1077	54	7	10-1107	13	57
10-1040	24	16	10-1077	79	16	01-2022	13	22
10-1042-2	18	33	10-1077	83	17	01-4019	13	21
10-1044	21	30	10-1078	27	18	10-1108-1-100	13	55
10-1045-2	19	11	10-1078-1	23	34	10-1109-2	67	29
10-1046-2	19	8	10-1078-1	68	13	10-1109-2	78	25
10-1049	19	16	10-1078-1	83	18	10-1109-2	86	7
10-1050	19	17	10-1080	88	4	10-1109-3	13	14
10-1051-1	23	9	10-1081	88	2	10-1113	9	2
10-1051-1	24	2	10-1082-0-001	88	16	10-1113	23	30
10-1052	24	17	10-1083	23	18	10-1113-0-350	69	8
10-1053	7	20	10-1083	86	1	10-1113-0-350	75	17
10-1053	24	18	10-1085	10	2	10-1113-1-350	59	22
10-1053	41	1	10-1086	10	7	10-1114	9	1
10-1054	24	11	10-1087	10	4	10-1116	9	7
10-1055	24	12	10-1088-0-050	10	15	10-1116	75	19
10-1056	24	19	10-1089	10	12	10-1117	9	3
10-1059	25	10	10-1090	10	17	10-1118	9	34
10-1060-2	25	8	10-1091-0-000	10	26	10-1119	9	28
10-1061-1	25	6	10-1152	19	18	10-1120	9	35
			01-2079	19	19	10-1120	23	29
						10-1121-0-017	9	22

## PARTS INDEX

PART NUMBER	PAGE	DET.	PART NUMBER	PAGE	DET.	PART NUMBER	PAGE	DET.
10-1122-0-010	9	30	10-1155-1	10	22	10-1190	88	5
10-1122-0-010*	9	30	10-1156	21	13	10-1193-0-004	47	56
10-1122-0-010	19	20	10-1156	78	20	10-1193-1	19	34
10-1122-0-011	19	20	10-1156-0-350	66	10	10-1193-2-001	19	24
10-1122-0-012	19	20	10-1158-1-050	23	5	10-1193-2-002	19	22
10-1122-0-013	19	20	10-1158-1			10-1194-0-003	92	10
10-1122-0-014	19	20	01-1113	23	32	10-1194-0-004	92	9
10-1122-0-015	19	20	01-4074	23	6	10-1194-0-007	11	4
10-1122-0-016	19	20	10-1158-1-050	54	9	10-1194-0-008	92	5
10-1122-0-017	24	6	10-1158-1-050	79	26	10-1194-0-009	92	14
10-1122-0-017	86	8	10-1159	54	10	10-1194-0-010	91	10
10-1122-0-979	19	20	10-1159	79	23	10-1194-0-013	11	3
10-1122-0-980	19	20	10-1159-1	23	21	10-1194-0-014	11	2
10-1122-0-997	24	6	10-1160	23	24	10-1194-0-014	91	9
10-1122-0-998	19	20	10-1160	54	21	10-1194-0-016	11	1
10-1122-0-998	24	6	10-1160-0-450	82	8	10-1194-0-016	91	12
10-1122-0-999	19	20	10-1162	79	12	10-1194-0-019	92	1
10-1122-0-999	24	6	10-1163	32	7	10-1194-0-020	92	8
10-1124	7	1	10-1164	32	7	10-1194-0-026	75	1
10-1125-2	7	21	10-1164	66	16	10-1194-0-028	91	6
10-1126	7	3	10-1164	75	34	10-1194-1-005	91	1
10-1127-3	7	16	10-1165-1	59	19	10-1194-1-006	91	8
10-1128	88	7	10-1165-1			10-1194-1-012	92	13
10-1129-1	88	10	10-1166	10	4	10-1198-1	58	36
10-1134	88	14	01-6029	10	5	10-1201	57	49
10-1135	23	13	10-1167-1	13	56	10-1201-0-001	57	49
10-1139-2	23	10	10-1168	13	10	10-1203	7	17
10-1140-2	23	11	10-1169	13	26	10-1203	57	46
10-1145-0-400	66	17	10-1170	13	42	10-1204-0-400	75	9
10-1145-0-400	74	1	10-1172-1-100	83	23	10-1204-2	55	12
10-1145-2	29	3	01-1113	83	16	10-1205-0-400	75	3
10-1147	21	27	10-1173	83	22	10-1205-1	55	2
10-1149	10	27	10-1174	82	10	10-1206	55	3
10-1150	47	64	10-1175	82	13	10-1206	75	5
10-1150-0-450	78	22	10-1176	82	15	10-1207	55	7
10-1151	88	18	10-1177	22	17	10-1207-0-400	75	8
10-1152	19	18	10-1178	23	2	10-1208	55	5
10-1153	21	10	10-1179	69	14	10-1208-0-400	75	7
10-1154-0-050	32	6	10-1179	75	15	10-1209	55	8
10-1164	32	7	10-1179-1	59	14	10-1209	75	13
01-6179	32	9	10-1180	50	3	10-1210-1	55	4
10-1154-0-050	86	10	10-1181	50	6	10-1210-1	75	11
10-1154-0-401	75	4	10-1186	59	18	10-1211	55	10
			10-1188	88	24	10-1213	55	11
						10-1214	55	1

PART NUMBER	PAGE	DET.	PART NUMBER	PAGE	DET.	PART NUMBER	PAGE	DET.
10-1214	75	2	10-1600-0-024	36		10-2013-0-350	67	1
10-1223	62	13	10-1600-0-024	75	14	10-2014	6	13
10-1225	62	4	10-1630	79	13	10-2014	51	40
10-1230	88	9	10-1631	79	32	10-2014	67	2
10-1231	88	28	10-1632	79	31	10-2015	6	11
10-1301	42	7	10-1633	79	28	10-2015	67	4
10-1301	81	14	10-1634	80	2	10-2016	9	21
10-1301	86	2	10-1703-3	58	37	10-2018-0-001	7	5
10-1325	42	12				10-2018-0-450	86	9
10-1326	42	21				10-2018-1	40	6
10-1326-0-023	42	21				10-2018-1-017	7	5
10-1327	42	18				10-2018-1-250	7	5
10-1328	42	17				10-2019	5	1
10-1329	42	14				10-2020	5	27
10-1330	42	20				10-2021	5	22
10-1330-0-023	42	20				10-2021-0-023	51	44
10-1400-1	47	48				10-2021-1-350	67	10
10-1401	47	53				10-2022	5	26
10-1401	89	23				10-2022	67	11
10-1402	47	52				10-2023	5	18
10-1402	89	22				10-2023-0-007	47	27
10-1404-1	47	3				10-2023-0-007	73	36
10-1405-1	47	13				10-2023-0-023	50	16
10-1406-1	47	38				10-2023-0-023	51	43
10-1409	47	39				10-2023-0-350	67	12
10-1410	47	45				10-2024	5	21
10-1550-0-002	36					10-2025	5	8
10-1550-0-002	65					10-2025-0-017	5	6
10-1545-0-004	36					10-2026	5	7
10-1550-0-004	65					10-2027-1	5	2
10-1550-0-006	36					10-2028-1	5	10
10-1550-0-006	65					10-2029	3	29
10-1550-0-008	65					10-2030	3	28
10-1550-0-010	36					10-2031	3	33
10-1550-0-010	65					10-2032	3	31
10-1550-0-011	36					10-2033	4	9
10-1550-0-011	65					10-2034	4	12
10-1600-0-012	36					10-2035	57	28
10-1600-0-012	75	14				10-2036	4	7
10-1600-0-016	36					10-2039-0-050	4	13
10-1600-0-016	75	14				10-2041	4	3
10-1600-0-018	36					10-2042	4	1
10-1600-0-018	75	14				01-4067	4	2
10-1600-0-020	36							
10-1600-0-020	75	14						

PART NUMBER	PAGE	DET.	PART NUMBER	PAGE	DET.	PART NUMBER	PAGE	DET.
10-2040-0-050	4	5	10-2050-1-750	3	20	10-2059-1	78	11
10-2041	4	3	10-2050-1-750	38	10	10-2059-1-300	57	20
10-2042	4	1	10-2050-1-751	3	20	10-2060-1	3	21
01-4067	4	2	10-2050-1-751	38	10	10-2060-1	57	3
			10-2050-1-751	57	5	10-2060-1-450	84	2
10-2041	4	3	10-2050-1-752	3	20	10-2061	13	30
10-2042	3	27	10-2050-1-752	38	10	10-2061-0-994	13	30
10-2042	4	1	10-2050-1-752	57	5	10-2062	82	12
10-2043-0-450	78	13	10-2050-1-753	3	20	10-2063	3	35
10-2043-0-462	84	19	10-2050-1-753	38	10	10-2065-1	40	4
10-2043-1-019	38	7	10-2050-1-753	57	5	10-2067	40	2
10-2043-1-019	57	56	10-2050-1-754	3	20	10-2068	40	1
10-2044-0-021	78	12	10-2050-1-754	38	10	10-2070-1	50	14
10-2044-0-023	84	20	10-2050-1-756	3	20	10-2071-1	50	12
10-2045-0-450	78	4	10-2050-1-756	38	10	10-2072	50	10
10-2045-0-462	84	17	10-2050-1-757	57	5	10-2073	50	8
10-2045-1	2	7	10-2050-1-758	57	5	10-2074	51	46
10-2045-1	38	3	10-2050-2-702	2	5	10-2075	51	48
10-2045-1	57	18	10-2050-2-701	38	2	10-2200	39	2
10-2047-0-017	3	16	10-2050-2-702	38	2	10-2200	60	9
10-2047-0-450	78	19	10-2050-2-704	57	6	10-2200-1-450	81	3
10-2047-0-462	84	1	10-2050-2-705	57	6	10-2201-2	39	1
10-2047-1-019	3	16	10-2050-2-706	57	6	10-2201-2	60	10
10-2047-1-019	38	8	10-2050-2-707	57	6	10-2202	57	25
10-2047-1-019	57	2	10-2050-2-708	2	5	10-2203	57	42
10-2048-0-001	3	19	10-2050-2-708	57	6	10-2204	57	41
10-2048-0-001	38	9	10-2050-2-712	2	5	10-2204-0-600	57	41
10-2048-0-002	3	19	10-2050-2-713	2	5	10-2205	57	34
10-2048-0-002	38	9	10-2050-2-713	38	2	10-2208-1	57	30
10-2048-0-002	57	23	10-2051-2	57	14	10-2210	57	24
10-2048-0-010	38	9	10-2051-2	3	25	10-2211	57	55
10-2048-0-011	57	23	10-2051-2	59	17	10-2211-0-001	57	10
10-2048-0-012	57	23	10-2052	3	26	10-2212-0-001	57	19
10-2048-0-014	57	23	10-2052	57	15	10-2212-1	57	8
10-2048-0-015	57	23	10-2053	2	3	10-2214	57	11
10-2048-0-016	57	23	10-2053	64	17	10-2215	57	45
10-2048-0-017	57	23	10-2053	84	13	10-2217	57	38
10-2048-0-018	3	19	10-2054	3	17	10-2218	57	36
10-2048-0-019	3	19	10-2054	64	9	10-2250-1	7	12
10-2048-0-022	84	22	10-2056	89	24			
10-2049	2	2	10-2057-1	47	54			
10-2049	38	1	10-2057-1	89	21			
10-2049	57	13	10-2058	42	4			
10-2049-0-462	84	12	10-2059-0-450	84	18			
10-2050-1-712	38	2	10-2059-1	2	9			



## PARTS INDEX

PART NUMBER	PAGE	DET.	PART NUMBER	PAGE	DET.	PART NUMBER	PAGE	DET.
10-3012	16	24	10-3033-0-017	42	3	10-3061-1	61	3
10-3012	29	11	10-3033-0-017	44	7	10-3061-1	62	17
10-3012-0-400	74	4	10-3033-0-017	48	25	10-3062-1	32	22
10-3013	29	19	10-3033-0-450	85	8	10-3062-1	44	1
10-3015-0-250	16	15	10-3034	42	2	10-3062-1	48	19
10-3015-0-250	29	13	10-3034	61	1	10-3062-1	68	23
10-3015-0-250	67	33	10-3034-0-258	15	1	10-3064-0-019	68	44
10-3016	16	16	10-3034-0-258*	14	13	10-3064-0-025	75	30
10-3016	29	16	10-3034-0-261	14	13	10-3064-0-026	85	22
10-3018	16	13	10-3034-0-261	15	1	10-3064-1-020	68	44
10-3018	29	14	10-3034-0-300	61	1	10-3064-1-021	68	44
10-3018-0-350	62	14	10-3034-0-300	69	1	10-3064-1-059	44	26
10-3018-0-350	67	32	10-3035-1	8	14	10-3066-0-008	8	12
10-3019	14	5	10-3036	8	15	10-3066-0-011	8	4
10-3019-0-001	41	15	10-3039	11	21	10-3067-2-253	60	28
10-3019-0-300	6	2	10-3040-1	11	23	10-3070-0-017	32	12
10-3019-1-006	15	3	10-3041	11	19	10-3070-0-017	33	18
10-3019-1-006	61	2	10-3042	11	20	10-3070-0-061	39	2
10-3019-1-006	69	22	10-3045	6	16	10-3078	39	10
10-3019-1-400	74	13	10-3045	11	18	01-3067	39	4
10-3020	14	2	10-3046	11	17	01-5070	39	3
10-3020-0-005	41	5	10-3047-1-050	11	11	10-3070-0-250	32	12
10-3020-0-006	15	6	01-4023	11	12	10-3070-0-250	33	18
10-3020-0-006	69	5	01-6028	11	9	10-3070-1-050	39	2
10-3020-0-007	61	27	10-3048	13	51	10-3078	39	10
10-3022	5	36	10-3049	11	7	01-3067	39	4
10-3022-0-023	51	41	10-3050	11	13	01-5070	39	3
10-3022-1-350	69	26	10-3051	11	8	10-3070-1-050	43	1
10-3023	5	28	10-3052	13	47	10-3070-1-250	47	31
10-3023	51	29	10-3053-1	13	13	10-3070-2-060*	47	31
10-3025	5	32	10-3054-2	13	32	10-3078	47	61
10-3026	5	31	10-3058-0-400	73	12	01-3067	47	62
10-3026	29	12	10-3058-0-462	86	16	01-5070	47	63
10-3027	16	23	10-3058-1-300	60	24	10-3071-0-017	33	4
10-3028	8	2	10-3061-0-150	5	33	10-3071-1	39	6
10-3029-0-008	6	17	10-3061-0-200	5	33	10-3071-1-250	33	4
10-3029-0-008	8	11	10-3061-0-200	44	3	10-3072-0-068	80	5
10-3029-1	6	17	10-3061-0-200	48	21	10-3072-0-070	86	17
10-3029-1	8	11	10-3061-0-300	5	33	10-3074-0-011	33	3
10-3029-1-350	69	2	10-3061-0-300	61	3	10-3075-1-992	33	17
10-3029-1-400	75	29	10-3061-0-300	62	17	10-3075-1-992	39	1
10-3030	8	8	10-3061-0-300	75	32	10-3075-1-992	60	31
10-3031	6	19	10-3061-0-350	69	24	10-3075-1-993	33	17
10-3032-1	8	3	10-3061-0-462	85	23			

PART NUMBER	PAGE	DET.	PART NUMBER	PAGE	DET.	PART NUMBER	PAGE	DET.
10-3075-1-993	39	1	10-3206	61	15	10-3402-0-023	50	17
10-3075-1-993	60	31	10-3206	68	4	10-3426	59	27
10-3078	39	10	10-3207	60	19	10-3426	75	25
10-3078	47	61	10-3207-0-200	39	11	10-3431-1-600	62	5
10-3079	13	52	10-3208	60	15	10-3432	62	11
10-3079-0-550	67	31	10-3209	60	14	10-3432-0-001	62	11
10-3079-0-550	78	23	10-3216-0-011	61	9	10-3502	59	28
10-3080	13	15	10-3216-0-600	61	8	10-3502	75	31
10-3081	13	12	10-3216-0-600	62	16	10-3507-0-001	62	4
10-3082	13	54	10-3217	61	14	10-3507-0-600	62	4
10-3083	13	43	10-3250-1	16	1	10-3514-0-001	62	4
10-3085-0-050	31	25	10-3252-1	16	6	10-3550-2	68	25
10-3203			10-3253	16	26	10-3551-2	68	26
10-3205			10-3254	16	10	10-3551-2-006	68	26
01-6015			10-3257	16	27	10-3554	66	22
10-3086	31	24	10-3258	16	19	10-3555	66	1
10-3089-2	31	18	10-3259-1-001	16	12	10-3556-0-008	66	19
10-3090	31	33	10-3259-1-002	16	12	10-3556-0-009	66	19
10-3090	61	21	10-3260-1	33	14	10-3600	75	28
10-3090	68	30	10-3261	33	11	10-3601	75	27
10-3091	68	31	10-3262-0-250	16	31	10-3604-1	73	16
10-3092	51	32	10-3300-0-006	15	4	10-3606	73	13
10-3093	50	21	10-3300-0-006	69	21	10-3607-1	46	2
10-3094	51	30	10-3301-0-400	74	12	10-3607-1	73	28
10-3200	61	6	10-3301-1-006	15	11	10-3608	74	11
10-3200	62	15	10-3301-1-006	69	17	10-3609-1	74	9
10-3200-0-350	69	25	10-3302	15	12	10-3610	73	15
10-3201-0-001	61	12	10-3302	69	18	10-3611	73	30
10-3201-1-200	61	12	10-3302	74	10	10-3612	73	33
10-3201-1-462	85	26	10-3303	15	7	10-3613	73	7
10-3202-0-050	31	30	10-3303	69	6	10-3625-2	81	19
10-3203	31	23	10-3325	41	14	10-3626-3	81	4
10-3205	31	45	10-3326	41	16	10-3627	81	29
01-6010	31	46	10-3327	41	12	10-3629-2	80	11
10-3202-0-050	61	25	10-3328-0-050	41	6	10-3630-1	80	9
10-3203	31	23	10-3350	41	3	10-3631-2	81	22
10-3203	31	24	10-3351-1	41	8	10-3632	81	24
10-3203	61	24	01-3022	41	9	10-3633	81	21
10-3205	31	45	01-4020	41	10	10-3634-0-351	68	7
10-3205	68	6	10-3020-005	41	5	10-3205	68	6
10-3206-1	31	28	10-3352	41	2	01-6010	68	34
01-7004	41	7	10-3401	47	25	10-3636	44	24
			10-3401-0-023	50	26	10-3636	48	16
			10-3402	47	26	10-3636-0-462	44	24

PART NUMBER	PAGE	DET.	PART NUMBER	PAGE	DET.	PART NUMBER	PAGE	DET.
10-3636-0-462	48	16	10-4008	28	5	10-4032	43	5
10-3636-0-462	85	11	10-4009	28	1	10-4032	47	18
10-3636-1-600	62	9	10-4010-0-450	80	16	10-4032	58	29
10-3637	44	15	10-4010-2	28	13	10-4032	27	41
10-3637	48	7	10-4010-2	58	7	10-4033-0-050	27	39
10-3637	85	20	10-4011-0-450	80	14	10-4033	27	41
10-3638	44	23	10-4012-0-012	73	14	10-4028	27	40
10-3638	48	15	10-4012-0-019	68	1	10-4034	27	46
10-3638-0-462	44	23	10-4012-0-023	86	14	01-5004	27	47
10-3638-0-462	48	15	10-4012-0-025	86	15	10-4034	27	46
10-3638-0-462	85	17	10-4012-1-017	80	3	10-4035	27	1
10-3638-1-600	62	9	10-4012-1-019	68	1	10-4036	27	25
10-3639	44	22	10-4013	27	28	10-4037	27	26
10-3639	48	14	10-4015	27	5	10-4039	28	8
10-3639	85	19	10-4015-0-450	80	24	10-4041	43	2
10-3640	80	13	10-4016	27	6	10-4041	47	14
10-3642	86	13	10-4017	27	4	10-4200	58	15
10-3643-0-050	59	13	10-4018	27	33	10-4202	31	41
<b>10-4000</b>			10-4019	27	30	10-4202-0-100	28	20
10-4001-1-001	59	1	10-4020	27	29	10-4202-0-402	68	38
01-2318	58	22	10-4021	27	22	10-4202-0-402	73	25
01-4015	58	23	10-4022	27	12	10-4202-1-460	81	15
01-5044	58	21	10-4023	24	24	10-4203	28	21
10-4217	58	20	10-4024	24	21	10-4203	31	44
10-4001-0-460	80	8	10-4025	29	20	10-4203	68	43
10-4001-0-462	86	15	10-4025-0-450	80	22	10-4205	60	1
10-4001-1-150	27	43	10-4026	27	20	10-4205-0-002	60	1
10-4001-1-150	68	2	10-4028	27	40	10-4206	60	5
10-4001-1-150	73	26	10-4029	27	42	10-4207	60	21
10-4001-1-200	27	11	10-4029	43	8	10-4208-0-050	58	2
10-4001-1-200	47	14	10-4029	47	21	10-4208	58	3
10-4001-1-301	58	14	10-4030	23	38	10-4209	58	1
10-4002	28	26	10-4030	27	14	10-4210	58	1
10-4002-0-016	80	15	10-4030	43	7	01-2136	58	4
10-4003	28	25	10-4030	47	20	10-4208-0-600	59	10
10-4004	28	4	10-4030	54	19	10-4209	58	3
10-4004-0-008	80	18	10-4030	68	15	10-4209-0-600	59	9
10-4005-2	28	2	10-4030	79	1	10-4210	58	1
10-4005-2-986	80	17	10-4030	83	1	10-4210-0-600	59	11
10-4006	28	6	10-4030-0-300	58	33	10-4211	58	13
10-4007	28	3	10-4031	27	44	10-4212	58	6
			10-4031	43	6	10-4213	58	5
			10-4031	47	19	10-4215	58	11
			10-4031	58	30			
			10-4032	27	45			

PART NUMBER	PAGE	DET.
10-4217	58	20
10-4218	58	34
10-4218-0-200	27	13
10-4219	58	35
10-4220	58	19
10-4220-0-600	59	12
10-4221	58	31
10-4222	59	7
10-4550	73	23
10-4600	28	14
10-4600	31	34
10-4600	68	42
10-4634-0-010	80	6
10-4634-0-010	81	9
<b>10-5000</b>		
10-5001	89	2
10-5002	89	4
10-5003-1	89	9
10-5004	89	7
10-5005	89	13
10-5006-1	89	14
01-2050	89	15
01-3040	89	17
01-4019	89	16
10-5006-1	89	14
10-5008-2	89	30
10-5009	47	51
10-5009	89	26
10-5011	89	6
10-5012	89	18
10-5013	89	20
10-5019	89	11
10-5020	89	1
10-5020-0-250	89	8

PART NUMBER	PAGE	DET.
<b>14-0000</b>		
14-1016-0-050	19	5
10-1016-2	19	7
10-1017-2	19	4
10-1042-2	19	33
14-1017	19	4
14-1035-0	21	11
14-1041	21	2
14-1043	21	29
14-1047	19	14
14-1058	25	9
14-1064-1	24	8
14-1067	24	13
14-1108-0-050	67	14
10-1108-0-050	13	20
10-1165-1-050	12	6
10-1165		
10-1166	12	4
01-6029	12	5
01-2030	13	7
01-3009	12	3
01-2011	12	2
14-1197-0	58	38
14-2069-0-050	31	9
14-2069-0-050	40	13
14-2254	31	3
14-2254	7	10
14-3002	33	7
14-3002	60	27
14-3004	25	2
14-3006-0-150	24	27
14-3006-0-165	24	27
14-3006-0-200	24	27
14-3017	16	14
13-3017	29	18
14-3087	31	22
14-3088	31	16
14-3251-0	16	2
14-4011-0-150	27	2

PART NUMBER	PAGE	DET.
14-4011-0-200	27	2
14-4012-1-013	58	10
14-4012-1-013	59	6
14-4030	27	14
14-4201	28	24
14-4201	31	40
14-4201	58	27
14-4201	68	35
14-5019-0-000	31	11
<b>20-0000</b>		
20-0054	54	6
20-0595-1	47	41
20-0684	54	2

