

MODEL : DTN - 552YP

PARTS LIST

Fig. 1

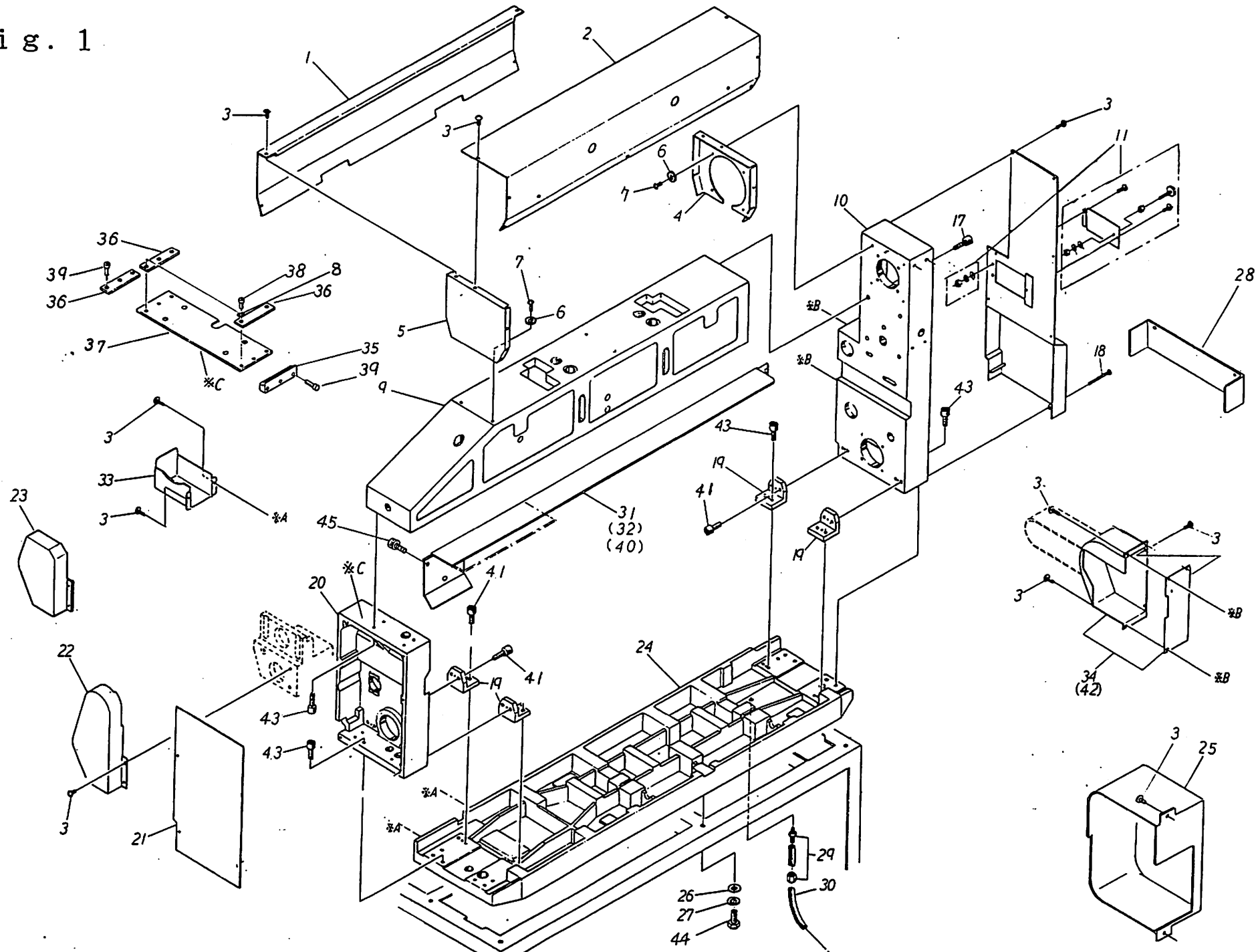

DTN-552YP, 550YP, 552B

Fig.	NO.	Code.	Name.	Q'ty
1	1	MB 171	Upper shaft cover, Rear	1
1	2	MB 170	Upper shaft cover, Front	1
1	3	4T8	Truss head screw 4x8	24
1	4	MB 46	Upper shaft cover lid, Right	1
1	5	MB 46-1	Upper shaft cover lid, left	1
1	6	5WL	Washer 5mm Large	6
1	7	5K10	Hexagon socket head screw 5x10	2
1	8	4SW	Spring washer 4mm	6
1	9	MB 179	Needle bar base frame	1
1	10	MB 32	Side plate, Right	1
1	11	MB 48	Right side plate panel, Set	1
1	17	8K30	Hexagon socket head screw 8x30	5
1	18	4P45	Cross recessed head screw 4x45	2
1	19	MB 37	Side plate bracket	4
1	20	MB 33	Side plate, Left	1
1	21	MB 177	Side plate panel, Left	1
1	22	MF 265	Gear cover (DTN-550YP)	1
1	23	MF 668	Gear cover (DTN-552YP, 552B)	1
1	24	MB 178	Base	1
1	25	MF 667	Brake cover (DTN-552YP, 552B)	1
1	26	8W	Washer 8mm	6
1	27	8SW	Spring washer 8mm	6
1	28	XWJUA501	Belt cover (DTN-552B)	1
1	29	H10-02	Union	1
1	30	VS10	Drain hose	1
1	31	MX 298	Lower feed roller cover (DTN-552YP)	1
1	32	MX 54	Lower feed roller cover (DTN-550YP)	1
1	33	MF 267	Cam clutch arm cover	1
1	34	MF 268	Brake cover (DTN-550YP)	1
1	35	MB 229	Plate positioning guide (DTN-552B)	1
1	36	MB 230	Positioning plate (DTN-552B)	3
1	37	MB 228	Side panel left plate (DTN-552B)	1
1	38	4K8	Hexagon socket head screw 4x8	6
1	39	4K15	Hexagon socket head screw 4x15	6
1	40	MX 299	Lower feed roller cover (DTN-552B)	1
1	41	8K20	Hexagon socket head screw 8x20	16
1	42	MF 270	Slitter pulley cover (DTN-550YP)	1
1	43	8K25	Hexagon socket head screw 8x25	12
1	44	8B25	Hexagon head bolt 8x25	6
1	45	6K10	Hexagon socket head screw 6x10	2



## DTN-552YP, 550YP, 552B

Fig.	NO.	Code.	Name	Q'ty
2	1	MM 51	Upper shaft 20x815	1
2	2	5-25	Alnico magnet 5x25	1
2	3	ME 11	Pulley for upper stop	1
2	4	8S12F	Hexagon socket set screw 8x12	1
2	5	AN05	sleeve nut	2
2	6	AW05	Sleeve washer	2
2	7	A2305	Sleeve	2
2	8	IM-07-81	Round flange unit with spigot joint UKFC205	2
2	9	GLS-S1	Proximity switch	1
2	10	ME 10	Upper stop detector base	1
2	11	4P12	Cross recessed head screw 4x12	2
2	12	10K40	Hexagon socket head screw 10x40	10
2	13	MB 38	20 Dia upper bearing bracket	1
2	14	8K30	Hexagon socket head screw 8x30	3
2	15	MN 57	Eccentric	2
2	16	10S15	Hexagon socket set screw 10x15	10
2	17	IM-09-25	Retaining ring H100	2
2	18	IM-07-82	Bearing 6914ZZ	2
2	19	IM-09-26	Retaining ring S70	2
2	20	MN 56	Crank	2
2	21	MF 233	Crank	2
2	22	IM-09-08	Retaining ring S35	2
2	23	IM-07-76	Bearing 6907ZZ	2
2	24	IM-09-18	Retaining ring H55	2
2	25	MF 244	Eccentric (DTN-552YP, 550YP)	2
2	25	MF 245	Eccentric (DTN-552B)	2
2	26	IM-07-40	Rhombic flange unit UFL004	3
2	27	MB 39	Upper bearing bracket, Inner	3
2	28	MM 32	Balancer	2
2	29	8S10	Hexagon socket set screw 8x10	4
2	30	T 158	Timing pulley 30S8M0250-A	1
2	31	IM-26-01	Power lock PL020-47	1
2	32	IM-20-18	Timing belt 250S-8M-1248L	1
2	33	IM-09-07	Retaining ring S15	2
2	34	MM 34	Idler	1
2	35	IM-09-01	Retaining ring H32	4
2	36	IM-07-39	Bearing 6002ZZ	4
2	37	MM 33	Idler shaft	2
2	38	12W	Washer 12mm	2
2	39	12SW	Spring washer 12mm	2
2	40	12N	Nut 12mm	2
2	41	10N	Nut 10mm	4
2	42	MN 58	Rod	2
2	43	10NL	Nut 10mm Left-hand thread	2
2	44	IM-22-10	Rod end HRTL-10	2

## DTN-552YP, 550YP, 552B

Fig.	NO.	Code.	Name	Q'ty
2	45	10W	Washer 10mm	4
2	46	MN 59	Needle bar	2
2	47	MN 60	Needle bar metal, Upper	2
2	48	5K20	Hexagon socket head screw 5x20	2
2	49	MT 91	Needle bar thread guide base	2
2	50	MN 62	Oil pot	2
2	51	3P12	Cross recessed head screw 3x12	2
2	52	MN 61	Needle bar metal, Lower	2
2	53	6S10	Hexagon socket set screw 6x10	4
2	54	MN 55	Needle clamp base	1
2	55	MT 117	Needle bar thread guide	1
2	56	5K10	Hexagon socket head screw 5x10	6
2	57	IM-25-01	Thread guide GP-S	134
2	58	5K12	Hexagon socket head screw 5x12	7
2	59	MN 120	Needle clamp thread guide P=12.7	1
2	59	MN 121	Needle clamp thread guide P=13.0 <OP.>	1
2	59	MN 122	Needle clamp thread guide P=12.5 <OP.>	1
2	59	MN 123	Needle clamp thread guide P=12.8 <OP.>	1
2	59	MN 125	Needle clamp thread guide P=11-21<OP.>	1
2	59	MN 145	Needle clamp thread guide P=12.0	1
2	60	MN 72	Needle clamp P=12.7	1
2	60	MN 74	Needle clamp P=13.0 <OP.>	1
2	60	MN 76	Needle clamp P=12.5 <OP.>	1
2	60	MN 78	Needle clamp P=12.8 <OP.>	1
2	60	MN 84	Needle clamp P=11-21 <OP.>	1
2	60	MN 88	Needle clamp P=12.0	1
2	61	DV-600	Needle DVx600	12
2	62	4T8	Truss head screw 4x8	12
2	63	8K25	Hexagon socket head screw 8x25	12
2	64	3N	Nut 3mm	2

Fig. 3

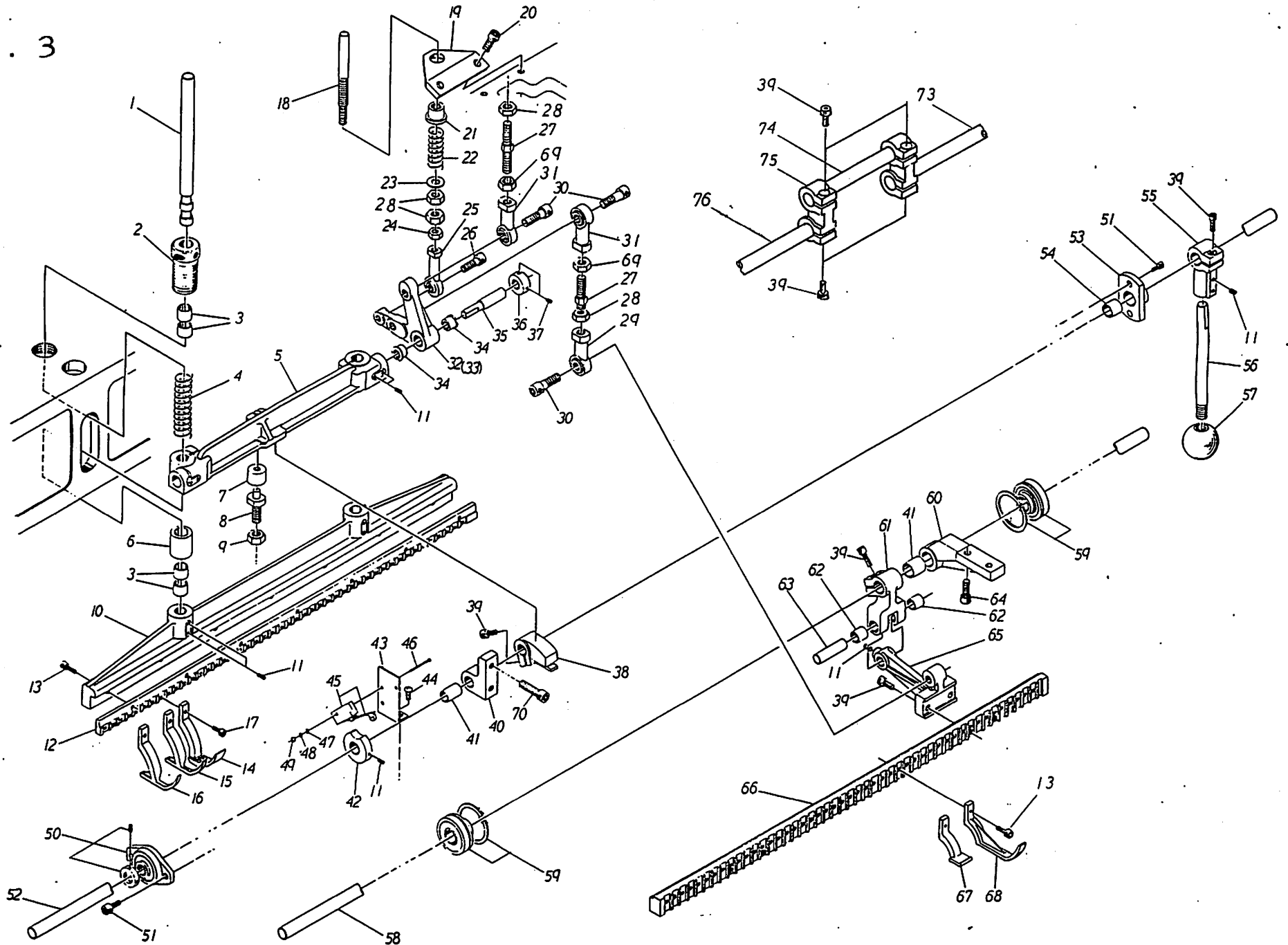

## DTN-552YP, 550YP

Fig.	NO.	Code	Name	Q'ty
3	1	MN 59	Needle bar	2
3	2	MP 37	Drum screw	2
3	3	IM-24-42	Oil-less bearing MR1412DU	8
3	4	J 183	Presser bar spring 17x75	2
3	5	MP 39	Presser bar guide bracket	1
3	6	MP 36	Presser bearing	2
3	7	MP 35	Presser stopper	1
3	8	MP 34	Presser stopper shaft	1
3	9	10N6	Nut 10mm	1
3	10	MP 38	Presser base	1
3	11	6S10	Hexagon socket set screw 6x10	13
3	12	MP 42	Presser foot mounting plate P=12.7	1
3	12	MP 43	Presser foot mounting plate P=13.0 <OP.>	1
3	12	MP 44	Presser foot mounting plate P=12.5 <OP.>	1
3	12	MP 45	Presser foot mounting plate P=12.8 <OP.>	1
3	12	MP 46	Presser foot mounting plate P=11-21 <OP.>	1
3	12	MP 72	Presser foot mounting plate P=12.0	1
3	13	5K15	Hexagon socket head screw 5x15	23
3	14	MP 73	Presser foot A P=12.0	1
3	14	MP 4538	Presser foot A P=13.0 <OP.>	1
3	14	MP 4545	Presser foot A P=12.5 <OP.>	1
3	14	MP 4547	Presser foot A P=12.7	1
3	14	MP 4555	Presser foot A P=11-21 <OP.>	1
3	15	MP 4568-1	Presser foot B with needle hole <OP.>	1
3	16	MP 4539	Presser foot B	1
3	17	5K12	Hexagon socket head screw 5x12	12
3	18	MF 248	Rod	2
3	19	MF 249	Auxiliary presser bar spring bearing base	2
3	20	8K15	Hexagon socket head screw 8x15	4
3	21	MF 247	Flanged collar	2
3	22	IM-16-10	Compression spring A15-03	2
3	23	10W	Washer 10mm	2
3	24	8N	Nut 8mm	2
3	25	IM-22-01	Rod end FBF-8	2
3	26	8K25	Hexagon socket head screw 8x25	2
3	27	MF 246	Rod	4
3	28	10N	Nut 10mm	8
3	29	IM-22-04	Rod end FBF-10	2
3	30	10K30	Hexagon socket head screw 10x30	6
3	31	IM-22-05	Rod end FBFL-10	4
3	32	MF 292	Bell crank, Right	1
3	33	MF 293	Bell crank, left	1
3	34	IM-24-11	Oil-less bearing MB1210-20FPU	4
3	35	MF 241	Pin	2
3	36	D 135	Collar 12x24-10	2

## DTN-552YP, 550YP

Fig.	NO.	Code	Name	Q'ty
3	37	5S6	Hexagon socket set screw 5x6	4
3	38	MP 31	Presser lift arm	1
3	39	6K20	Hexagon socket head screw 6x20	8
3	40	MP 30	Presser lift bearing	1
3	41	IM-24-50	Oil-less bearing MB1512DU	3
3	42	ME 14	Switch cam	1
3	43	ME 15	Switch base	1
3	44	4T8	Truss head screw 4x8	2
3	45	V10-1A	Micro-switch V10-1A	1
3	45	VAM22	Actuator VAM22	1
3	46	3P25	Cross recessed head screw 3x25	2
3	47	3W	Washer 3mm	2
3	48	3SW	Spring washer 3mm	2
3	49	3N	Nut 3mm	2
3	50	IM-07-18	Rhombic flange unit UFL002	1
3	51	6K15	Hexagon socket head screw 6x15	4
3	52	B 257	Shaft 15x1180L	1
3	53	MP 41	Presser lever bearing	1
3	54	IM-24-10	Oil-less bearing MB1515DU	1
3	55	MP 32	Presser lift lever	1
3	56	MP 33	Presser lift handle	1
3	57	IM-15-06	Knob PC40-12	1
3	58	B 250	Shaft 15x1090L (DTN-550YP)	1
3	59	IM-07-57	Ball bearing for unit ASS202N	2
3	60	MF 234	Upper feed bearing	2
3	61	MF 235	Upper feed arm	2
3	62	IM-24-41	Oil-less bearing MB1212DU	4
3	63	ML 56	Thread unraveller swing main lever shaft	2
3	64	8K25	Hexagon socket head screw 8x25	4
3	65	MF 236	Upper feed base bracket	2
3	66	MF 255	Upper feed base P=12.7	1
3	66	MF 257	Upper feed base P=13.0 <OP.>	1
3	66	MF 259	Upper feed base P=12.5 <OP.>	1
3	66	MF 261	Upper feed base P=12.8 <OP.>	1
3	66	MF 264	Upper feed base P=11-21 <OP.>	1
3	66	MF 321	Upper feed base P=12.0	1
3	67	MF 1762	Upper feed B	12
3	67	MF 323	Upper feed B P=12.0	12
3	68	MF 1761	Upper feed A	6
3	69	10NL	Nut 10mm Left-hand thread	4
3	70	8K45	Hexagon socket head screw 8x45	2
3	73	B 238	Shaft 15x745L (DTN-552YP)	1
3	74	B 213	Shaft 15x84L (DTN-552YP)	1
3	75	MF 654	Upper feed shaft rod (DTN-552YP)	2
3	76	B 221	Shaft 15x280L (DTN-552YP)	1

Fig. 4

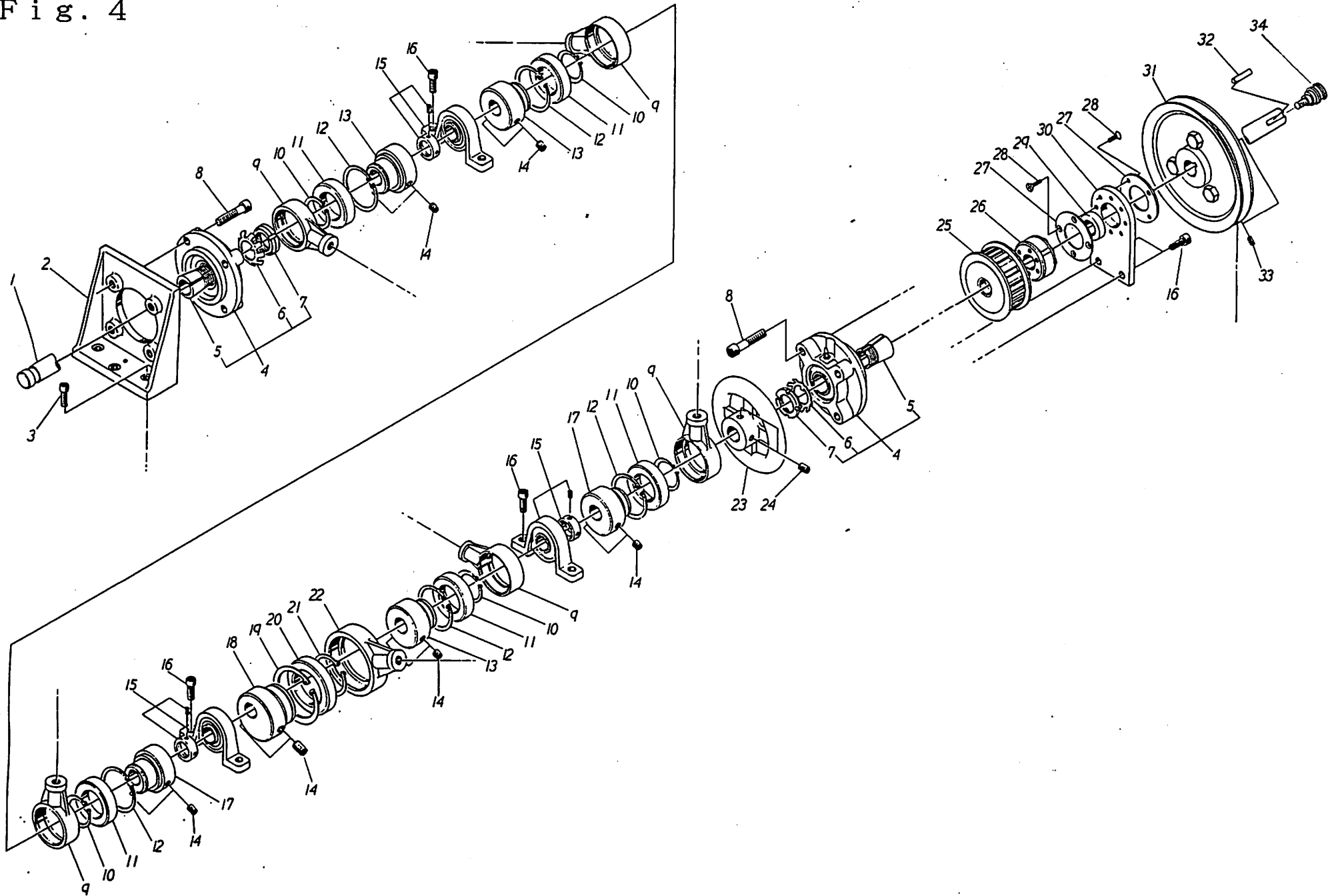

## DTN-552YP, 550YP

Fig.	NO.	Code	Name	Q'ty
4	1	MM 37N	Lower shaft	1
4	2	MB 40	Lower shaft bearing bracket	1
4	3	8K30	Hexagon socket head screw 8x30	3
4	4	IM-07-81	Round flange unit with spigot joint UKFC205	2
4	5	A2305	Sleeve	2
4	6	AW05	Sleeve washer	2
4	7	AN05	Sleeve Nut	2
4	8	10K40	Hexagon socket head screw 10x40	8
4	9	MF 233	Crank	5
4	10	IM-09-08	Retaining ring S35	5
4	11	IM-07-76	Bearing 6907ZZ	5
4	12	IM-09-18	Retaining ring H55	5
4	13	MF 243	Eccentric	3
4	14	10S15	Hexagon socket set screw 10x15	12
4	15	IM-07-66	Pillow block unit UP004	3
4	16	8K25	Hexagon socket head screw 8x25	8
4	17	MF 245	Eccentric	2
4	18	ML 74	Eccentric	1
4	19	IM-09-19	Retaining ring H68	1
4	20	IM-07-75	Bearing 6909ZZ	1
4	21	IM-09-13	Retaining ring S45	1
4	22	ML 73	Crank	1
4	23	MM 31	Manual pulley	1
4	24	8S8	Hexagon socket set screw 8x8	2
4	25	T 158	Timing pulley 30S8M0250-A	1
4	26	IM-26-01	Power lock PLO20-47	1
4	27	MS 2305	Bearing cover	2
4	28	4F8	Flat head screw 4x8	8
4	29	IM-07-23	Bearing 6904ZZ	1
4	30	MB 42	Bearing plate	1
4	31	V 320	Pulley 6.5A1-20	1
4	32	6x6-32HR	Woodruff key 6x6-32	1
4	33	6S12	Hexagon socket set screw 6x12	1
4	34	NZDGL50	Detector mounting screw	1

Fig. 5

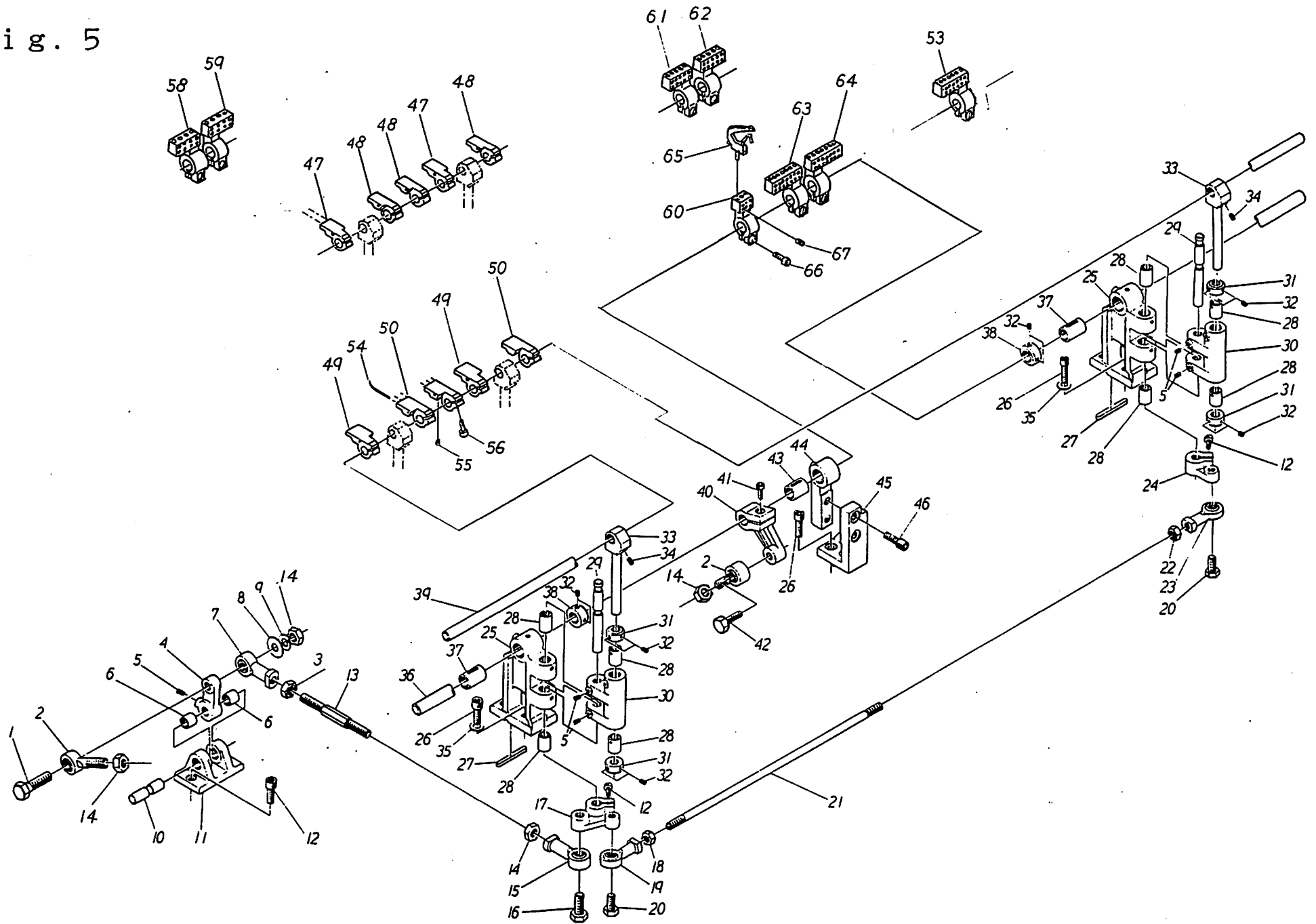

## DTN-552YP, 550YP, 552B

Fig.	NO.	Code.	Name.	Q'ty
5	1	10B50	Hexagon Head bolt 10x50	1
5	2	1M-22-11	Rod end HRT-10E	2
5	3	10NL	Nut 10mm Left-hand thread	1
5	4	ML 78	Thread unraveller swing lever	1
5	5	6S8	Hexagon socket set screw 6x8	5
5	6	1M-24-41	Oil-less bearing MB1212DU	2
5	7	1M-22-10	Rod end HRTL-10	2
5	8	10W	Washer 10mm	1
5	9	10SW	Spring washer 10mm	1
5	10	ML 56	Thread unraveller swing main lever shaft	1
5	11	ML 53	Thread unraveller swing main lever base	1
5	12	6K18	Hexagon socket head screw 6x18	4
5	13	ML 84	Rod	1
5	14	10N	Nut 10mm	4
5	15	1M-22-09	Rod end HRT-10	1
5	16	10B25	Hexagon Head bolt 10x25	1
5	17	ML 80	Thread unraveller lever	1
5	18	8N	Nut 8mm	1
5	19	1M-22-07	Rod end HRT-8	1
5	20	8B20	Hexagon Head bolt 8x20	2
5	21	ML 85	Rod	1
5	22	8NL	Nut 8mm Left-hand thread	1
5	23	1M-22-08	Rod end HRTL-8	1
5	24	ML 81	Thread unraveller guide lever	1
5	25	ML 71	Looper bearing base, Outer	2
5	26	8K25	Hexagon socket head screw 8x25	6
5	27	6x6-40	Key 6x6-40	2
5	28	ML 77	Bush	8
5	29	ML 83	Thread unraveller pin	2
5	30	ML 79	Thread unraveller bearing	2
5	31	D 214	Collar 10x20-9	4
5	32	5S5	Hexagon socket set screw 5x5	12
5	33	ML 82	Thread unraveller connecting shaft	2
5	34	6S10	Hexagon socket set screw 6x10	2
5	35	8W	Washer 8mm	4
5	36	B 602	Shaft 14x540L	1
5	37	ML 75	Bush	2
5	38	D 218	Collar 14x25-10	2
5	39	B 601	Shaft 12x570L	1
5	40	ML 72	Looper connecting lever	1
5	41	6K20	Hexagon socket head screw 6x20	1
5	42	10B30	Hexagon Head bolt 10x30	1
5	43	ML 76	Bush	1
5	44	ML 125	Looper bearing, Center	1
5	45	ML 124	Looper bearing Center base	1

## DTN-552YP, 550YP

Fig.	NO.	Code.	Name.	Q'ty
5	46	8K30	Hexagon socket head screw 8x30	2
5	47	ML 123	Thread unraveller base, Left P=11 <OP.>	2
5	48	ML 122	Thread unraveller base, Right P=11 <OP.>	12
5	49	ML 110	Thread unraveller base, Left P=12.7	2
5	49	ML 111	Thread unraveller base, Left P=12.5 <OP.>	2
5	49	ML 112	Thread unraveller base, Left P=13.0 <OP.>	2
5	49	ML 136	Thread unraveller base, Left P=12.0	2
5	50	ML 107	Thread unraveller base, Right P=12.7	10
5	50	ML 108	Thread unraveller base, Right P=12.5 <OP.>	10
5	50	ML 109	Thread unraveller base, Right P=13.0 <OP.>	10
5	50	ML 133	Thread unraveller base, Right P=12.0	10
5	53	ML 151	Looper base, 6 P=12.0 <OP.>	1
5	54	ML 3556	Thread unraveller	12
5	55	3S6	Hexagon socket set screw 3x6	12
5	56	4K12	Hexagon socket head screw 4x12	12
5	58	ML 120	Looper base, Right P=11-21 <OP.>	7
5	59	ML 121	Looper base, Left P=11-21 <OP.>	5
5	60	ML 97	Looper base P=12.5 <OP.>	1
5	60	ML 98	Looper base P=13.0 <OP.>	1
5	60	ML 148	Looper base P=12.0 <OP.>	1
5	61	ML 89	Looper base, Right 5 P=12.7 <OP.>	1
5	61	ML 132	Looper base, Right 5 P=12.0 <OP.>	1
5	62	ML 96	Looper base, Left 5 P=12.0 <OP.>	1
5	63	ML 87	Looper base, Right P=12.7	6
5	63	ML 99	Looper base, Right P=12.5 <OP.>	6
5	63	ML 100	Looper base, Right P=13.0 <OP.>	5
5	63	ML 130	Looper base, Right P=12.0	7
5	64	ML 88	Looper base, Left P=12.7	5
5	64	ML 101	Looper base, Left P=12.5 <OP.>	5
5	64	ML 102	Looper base, Left P=13.0 <OP.>	6
5	64	ML 131	Looper base, Left P=12.0	5
5	65	ML 20	Looper	12
5	66	5K15	Hexagon socket head screw 5x15	12
5	67	4S8	Hexagon socket set screw 4x8	24

Fig. 6

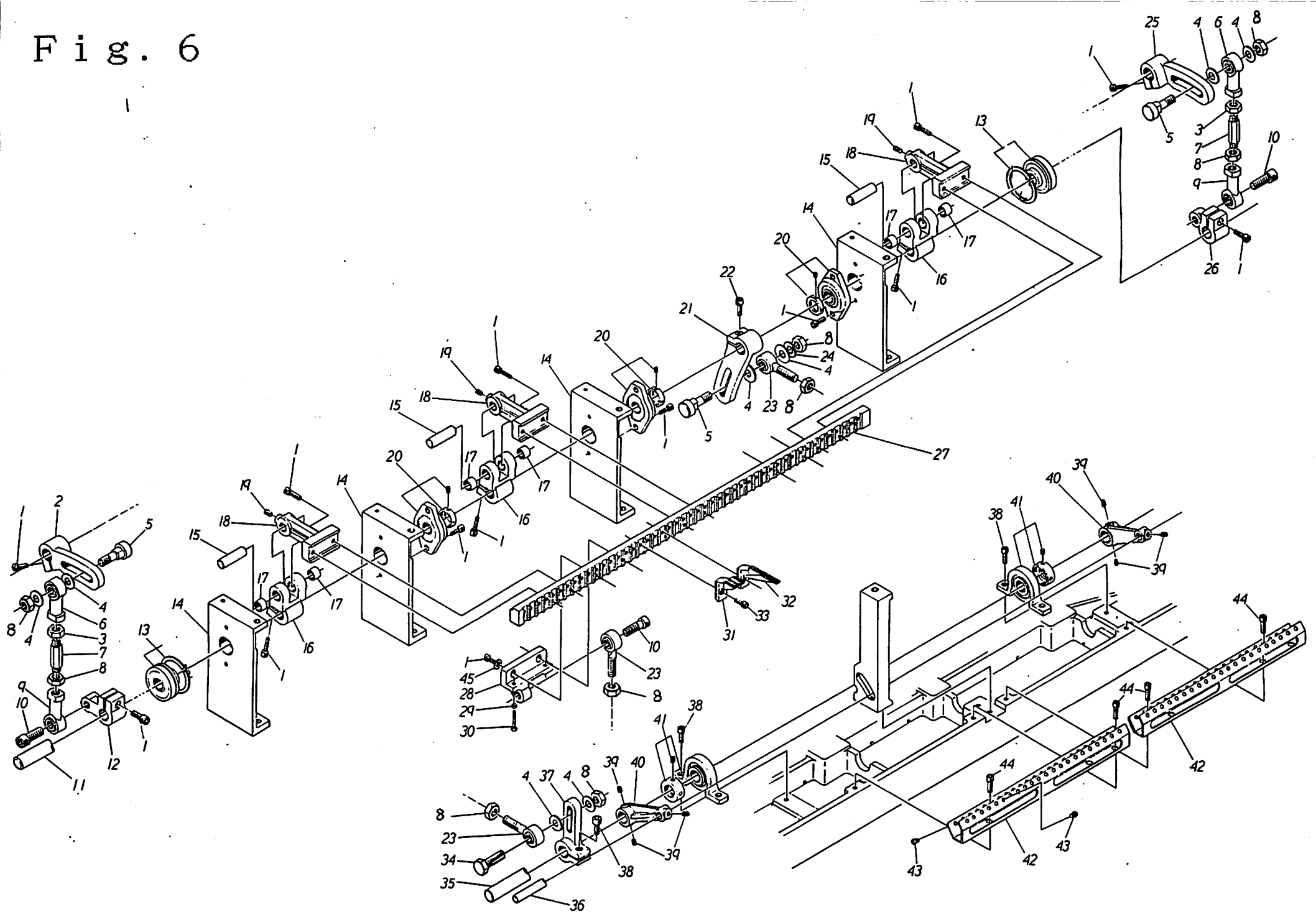

## DTN-552YP, 550YP

Fig.	NO.	Code.	Name.	Q'ty
6	1	6K20	Hexagon socket head screw 5x15	23
6	2	MF 238	Upper feed adjust lever, Left	1
6	3	10NL	Nut 10mm Left-hand thread	2
6	4	10W	Washer 10mm	8
6	5	MF 242	Pin screw	3
6	6	IM-22-05	Rod end FRFI-10	2
6	7	BEEFB001	Rod	2
6	8	10N	Nut 10mm	9
6	9	IM-22-04	Rod end FBF-10	2
6	10	10K25	Hexagon socket head screw 10x25	4
6	11	B 250	Shaft 15x1090L	1
6	12	MF 231	Feed rod arm, Left	1
6	13	IM-07-57	Ball bearing for unit ASS202N	2
6	14	MB 36	Needle plate bracket, Rear	4
6	15	ML 56	Thread unraveller swing main lever shaft	3
6	16	MF 229	Horizontal feed arm	3
6	17	IM-24-41	Oil-less bearing MB1212DU	6
6	18	MF 228	Lower feed base	3
6	19	6S8	Hexagon socket set screw 6x8	3
6	20	IM-07-18	Rhombic flange unit bearing UFL002	3
6	21	MF 227	Feed adjust lever	1
6	22	8K20	Hexagon socket head screw 8x20	1
6	23	IM-22-06	Rod end FBM-10	4
6	24	10SW	Spring washer 10mm	1
6	25	MF 237	Upper feed adjust lever, Right	1
6	26	MF 230	Feed rod arm, Right	1
6	27	MF 254	Lower feed base P=12.7	1
6	27	MF 256	Lower feed base P=13.0 <OP.>	1
6	27	MF 258	Lower feed base P=12.5 <OP.>	1
6	27	MF 260	Lower feed base P=12.8 <OP.>	1
6	27	MF 263	Lower feed base P=11-21 <OP.>	1
6	27	MF 322	Lower feed base P=12.0	1
6	28	MF 232	Feed vertical adjust base	2
6	29	5N	Nut 5mm	4
6	30	5B20	Hexagon Head bolt 5x20	4
6	31	MF 1786	Feed A P=12.7, 12.5, 13.0, 12.8	22
6	31	MF 1786	Feed A P=12.0	24
6	31	MF 1791	Feed A P=11-21 <OP.>	18
6	32	MF 324	Feed B P=12.0	13
6	32	MF 1752	Feed B P=12.7, 12.5, 13.0, 12.8	12
6	32	MF 1752	Feed B P=11-21 <OP.>	9
6	33	5K15	Hexagon socket head screw 5x15	12
6	34	MT 60	Lower thread take-up lever adjust screw	1
6	35	B 232	Shaft 15x650L	1
6	36	B 608	Shaft 8x600L	1

## DTN-552YP, 550YP

Fig.	NO.	Code.	Name.	Q'ty
6	37	MT 61	Lower thread take-up lever adjust lever	1
6	38	6K15	Hexagon socket head screw 6x15	5
6	39	6S6	Hexagon socket set screw 6x6	6
6	40	MT 90	Lower thread take-up lever	2
6	41	IM-07-56	Pillow block unit UP002	2
6	42	MT 119	Lower thread take-up lever thread guide	2
6	43	IM-25-01	Thread guide, Small GP-S	88
6	44	6K10	Hexagon socket head screw 6x10	4
6	45	6W	Washer 6mm	4

Fig. 7

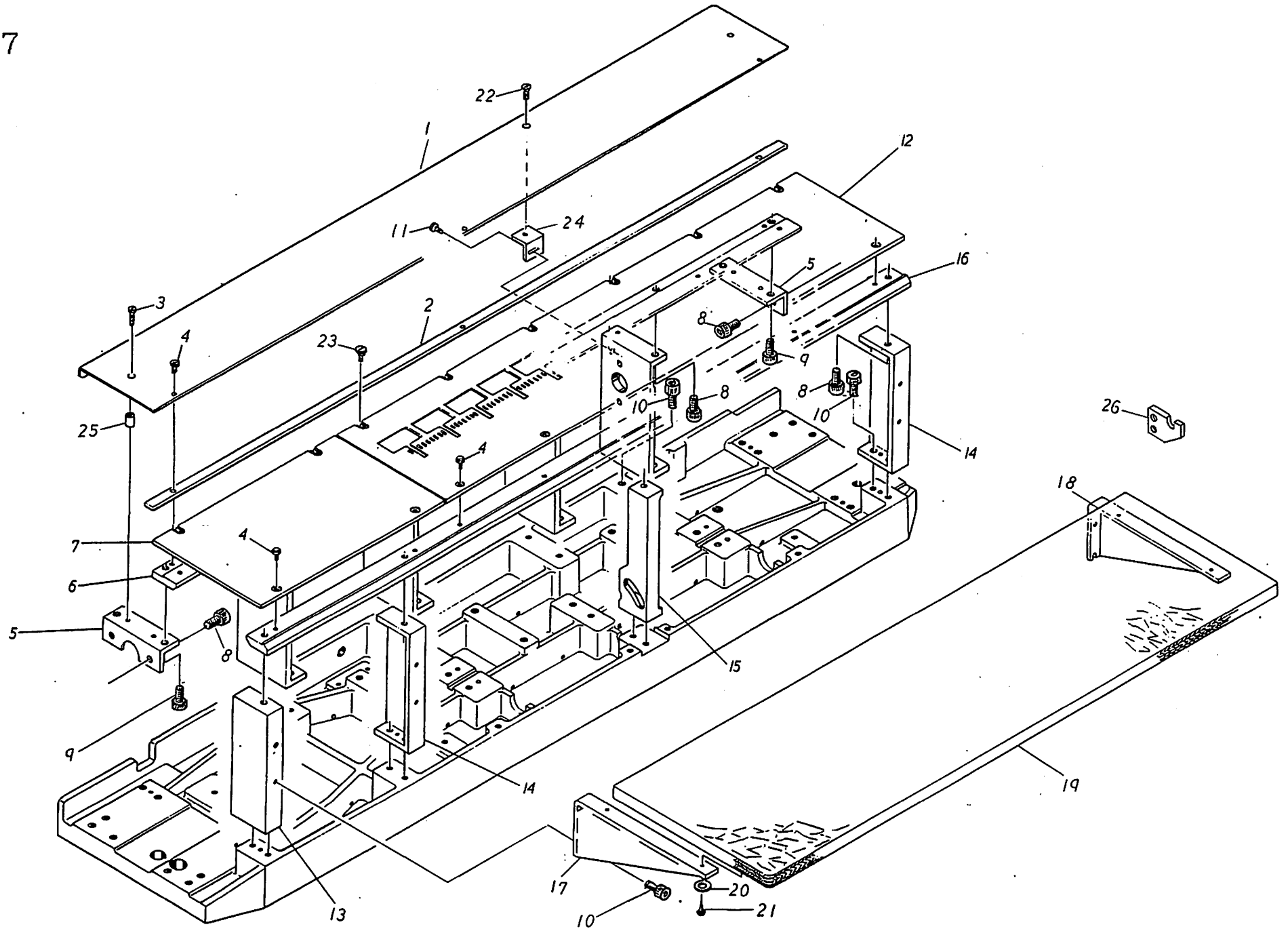

## DTN-552YP, 550YP

Fig. NO.	Code.	Name	Q'ty
7 1	MB 249	Slide plate	1
7 2	MB 250	Slide plate keep plate	1
7 3	4P15	Cross recessed head screw 4x15	2
7 4	N 343	Needle plate set screw 11/64-6	13
7 5	MB 41	Needle plate base bracket	2
7 6	MN 69	Needle plate base, Rear	1
7 7	MN 70	Needle plate base plate	1
7 8	6K15	Hexagon socket head screw 6x15	12
7 9	6K12	Hexagon socket head screw 6x12	2
7 10	6K18	Hexagon socket head screw 6x18	20
7 11	4K8	Hexagon socket head screw 4x8	1
7 12	MN 71	Needle plate P=6.35x7	1
7 12	MN 73	Needle plate P=6.5x7 <OP.>	1
7 12	MN 75	Needle plate P=6.25x7 <OP.>	1
7 12	MN 77	Needle plate P=6.4x7 <OP.>	1
7 12	MN 83	Needle plate P=11-21 <OP.>	1
7 12	MN 90	Needle plate P=6.0x7	1
7 12	MN 92	Needle plate P=6.0x7 <OP.>	1
7 12	MN 97	Needle plate P=6.35x7 <OP.>	1
7 12	MN 98	Needle plate P=6.0x7 <OP.>	1
7 12	MN 111	Needle plate P=6.0x7 <OP.>	1
7 13	MB 175	Needle plate bracket, Left	1
7 14	MB 174	Needle plate bracket, Right	2
7 15	MB 35	Needle plate bracket, Front	1
7 16	MB 68	Needle plate base, Front	1
7 17	MB 183L	Table bracket, Left	1
7 18	MB 183R	Table bracket, Right	1
7 19	MB 248	Table	1
7 20	5WL	Washer 5mm Large	4
7 21	3.5WS20	Wood screw 3.5x20	4
7 22	4F8	Flat head screw 4x8	1
7 23	N 463	Shoulder bolt 6x5.5-11/64	6
7 24	MB 241	Slide plate support	1
7 25	N 193	Ring 5x12-9	2
7 26	MB 196	Table positioning plate <OP.>	2

Fig. 8

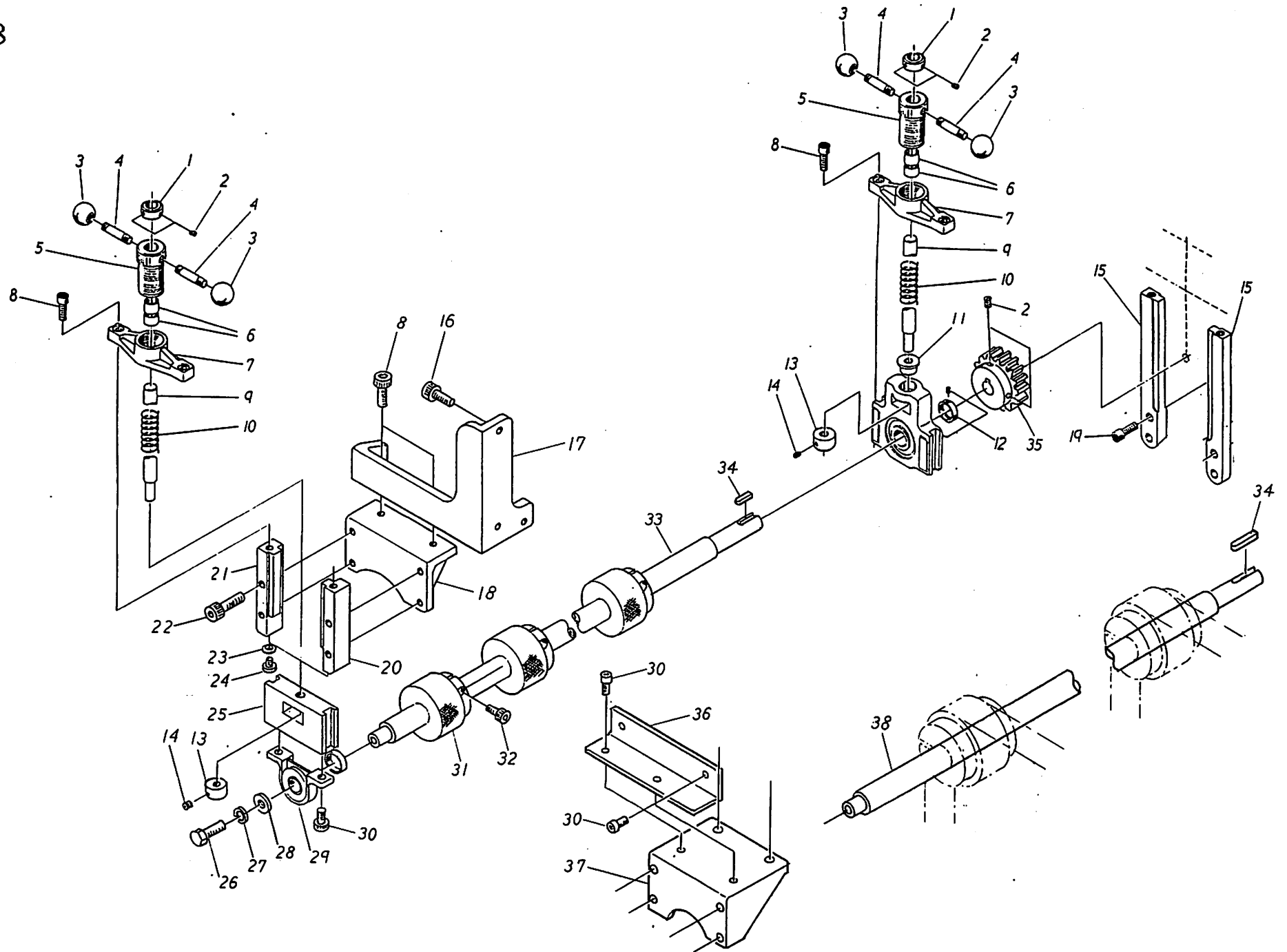

## DTN-552YP, 552B

Fig. NO.	Code	Name	Q'ty
8	1	D 127 Collar 10x25-12	2
8	2	6S6 Hexagon socket set screw 6x6	4
8	3	IM-15-05 knob PC25-8	4
8	4	MF 1739 Feed roller adjust handle	2
8	5	MP 37 Drum screw	2
8	6	IM-24-42 Oil-less bearing MB1412DU	4
8	7	MF 201 Feed adjust base	2
8	8	8K20 Hexagon socket head screw 8x20	6
8	9	MF 203 Feed roller adjust base shaft	2
8	10	IM-16-09 Compression spring A21-02	2
8	11	MF 204 Flange collar	1
8	12	MF 1735 Feed roller adjust bearing	1
8	13	D 218 Coller 14x25-10	2
8	14	5S4 Hexagon socket set screw 5x4	4
8	15	MF 202 Feed roller bearing guide	2
8	16	8K25 Hexagon socket head screw 8x25	3
8	17	MF 655 Bearing guide bracket	1
8	18	MF 657 Bearing guide mounting plate (DTN-552YP)	1
8	19	8K30 Hexagon socket head screw 8x30	4
8	20	MF 658 Feed roller bearing guide A	1
8	21	MF 659 Feed roller bearing guide B	1
8	22	8K35 Hexagon socket head screw 8x35	4
8	23	5WL Washer 5mm Large	2
8	24	5K10 Hexagon socket head screw 5x8	2
8	25	MF 660 Feed roller bearing base	1
8	26	8B15 Hexagon Head bolt 8x15	1
8	27	8SW Spring washer 8mm	1
8	28	8WL Washer 8mm Large	1
8	29	IM-07-48 Pillow block unit UP003	1
8	30	6K15 Hexagon socket head screw 6x15	2
8	31	MF 663 Feed roller, Upper (DTN-552YP)	5
8	32	6K20 Hexagon socket head screw 6x20	5
8	33	MF 634 Drive roller shaft, Upper (DTN-552YP)	1
8	34	6x6-30HR Woodruff key 6x6-30	1
8	35	G 305 Gear M4N16-20	1
8	36	B1LNZ503 Guide mount base bracket (DTN-552B)	1
8	37	MF 656 Bearing guide mounting plate (DTN-552B)	1
8	38	MF 636 Drive roller shaft, Upper (DTN-552B)	1

Fig. 9

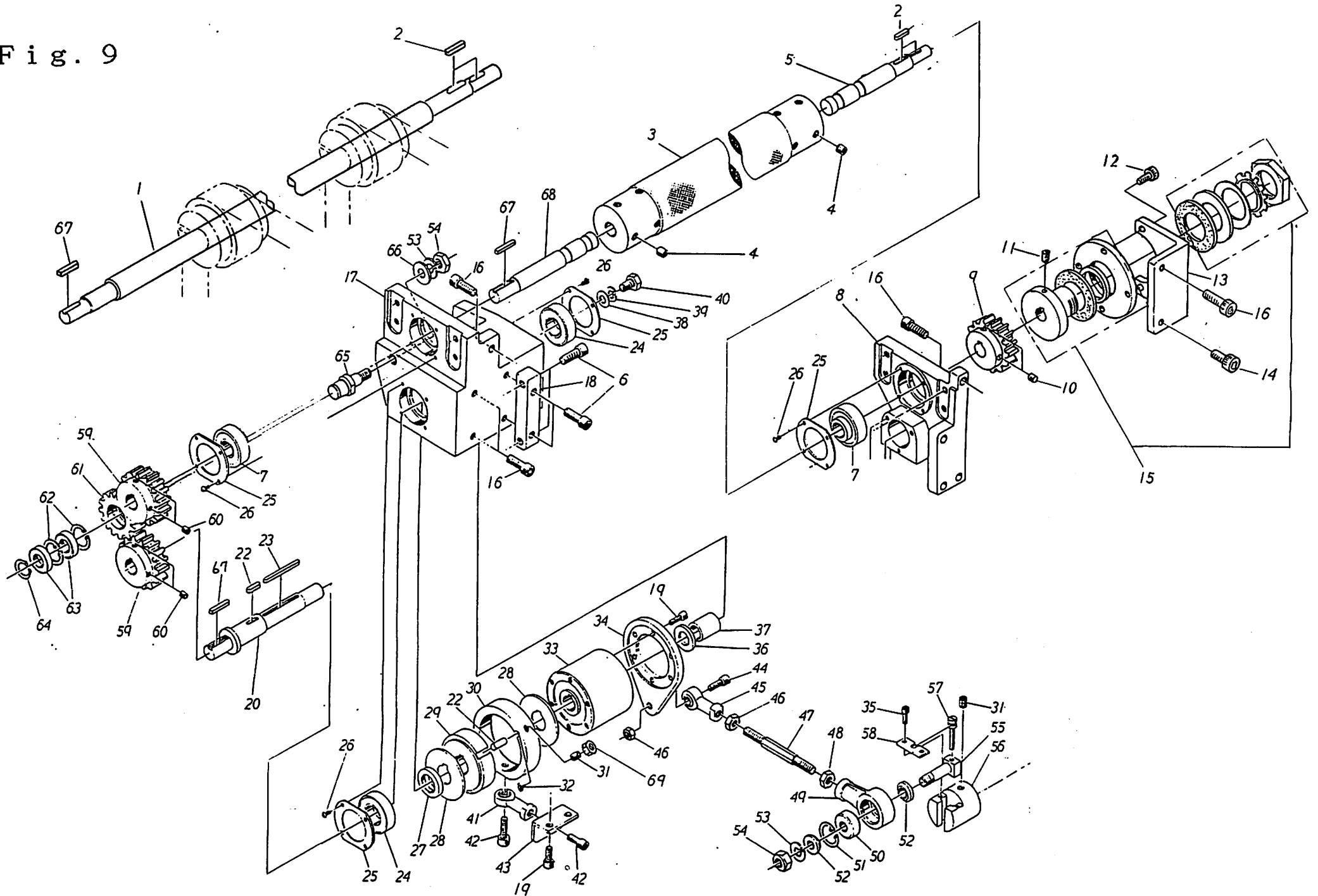

## DTN-552YP, 552B

Fig. NO.	Code.	Name.	Q'ty
9	1	MF 635 Drive roller shaft, Lower (DTN-552B)	1
9	2	6x6-30 Key 6x6-30	2
9	3	MF 703 Drive roller (DTN-552YP)	1
9	4	10S20 Hexagon socket set screw 10x20 (DTN-552YP)	8
9	5	MF 664 Feed roller brake shaft (DTN-552YP)	1
9	6	8K35 Hexagon socket head screw 8x35	4
9	7	IM-07-79 Ball bearing for unit ASS204N	2
9	8	MF 199 Feed roller base, Right	1
9	9	G 305 Gear M4N16-20	1
9	10	6S6 Hexagon socket set screw 6x6	2
9	11	5S10 Hexagon socket set screw 5x10	2
9	12	6K15 Hexagon socket head screw 6x15	3
9	13	MF 665 Brake bracket	1
9	14	8K20 Hexagon socket head screw 8x20	4
9	15	MF 666 Feed roller brake, Set	1
9	16	8K25 Hexagon socket head screw 8x25	2
9	17	MF 200 Feed roller base, Left	1
9	18	MF 220 Feed base mounting plate	1
9	19	6K12 Hexagon socket head screw 6x12	8
9	20	MF 253 Cam clutch shaft	1
9	22	7x7-18 Key 7x7-18	1
9	23	5x5-56 Key 5x5-56	1
9	24	IM-07-36 Bearing 6005ZZ	2
9	25	MF 212 Flange	4
9	26	5T8 Truss head screw 5x8	16
9	27	W 340 Ring 25x35-6	1
9	28	MF 266 Cam clutch washer	2
9	29	IM-02-01 Cam clutch 1D-07	1
9	30	MF 210 Back stop ring	1
9	31	8S12 Hexagon socket set screw 8x12	4
9	32	4T6 Truss head screw 4x6	2
9	33	IM-02-02 Cam clutch PNC20X	1
9	34	MF 209 Cam clutch arm	1
9	35	5K10 Hexagon socket head screw 5x10	2
9	36	18W Washer 18mm	1
9	37	W 341 Ring 9x25-28.5	1
9	38	W 133 Washer 10x25-4	1
9	39	10SW Spring washer 10mm	1
9	40	10B20 Hexagon Head bolt 10x20	1
9	41	IM-22-12 Rod end JAF-8	1
9	42	8K15 Hexagon socket head screw 8x15	4
9	43	MF 211 Stop ring baffle	1
9	44	10K25 Hexagon socket head screw 10x25	1
9	45	IM-22-04 Rod end FBF-10	1
9	46	10N Nut 10mm	2

## DTN-552YP, 552B

Fig. NO.	Code.	Name.	Q'ty
9	47	MF 274 Rod	1
9	48	10NL Nut 10mm Left-hand thread	1
9	49	MF 217 Crank	1
9	50	IM-07-70 Bearing 6201ZZ	1
9	51	IM-09-01 Retaining ring H32	1
9	52	W 339 Ring 12.1x22-5	2
9	53	12SW Spring washer 12mm	2
9	54	12N Nut 12mm	2
9	55	MF 218 Feed crank set screw	1
9	56	MF 214 Feed pitch adjust base	1
9	57	MF 215 Feed adjust screw	1
9	58	MF 216 Feed adjust screw guide	1
9	59	G 233 Gear M3N21-19	2
9	60	6S8 Hexagon socket set screw 6x8	4
9	61	G 234 Gear M3N18-30	1
9	62	IM-09-23 Retaining ring H30	2
9	63	IM-07-80 Bearing 6903ZZ	2
9	64	IM-09-24 Retaining ring S17	1
9	65	MF 213 Idler shaft	1
9	66	12W Washer 12mm	1
9	67	6x6-32 Woodruff key 6x6-32	2
9	68	MF 704 Feed roller shaft, Left	1
9	69	8N NUT 8mm	1

Fig. 10

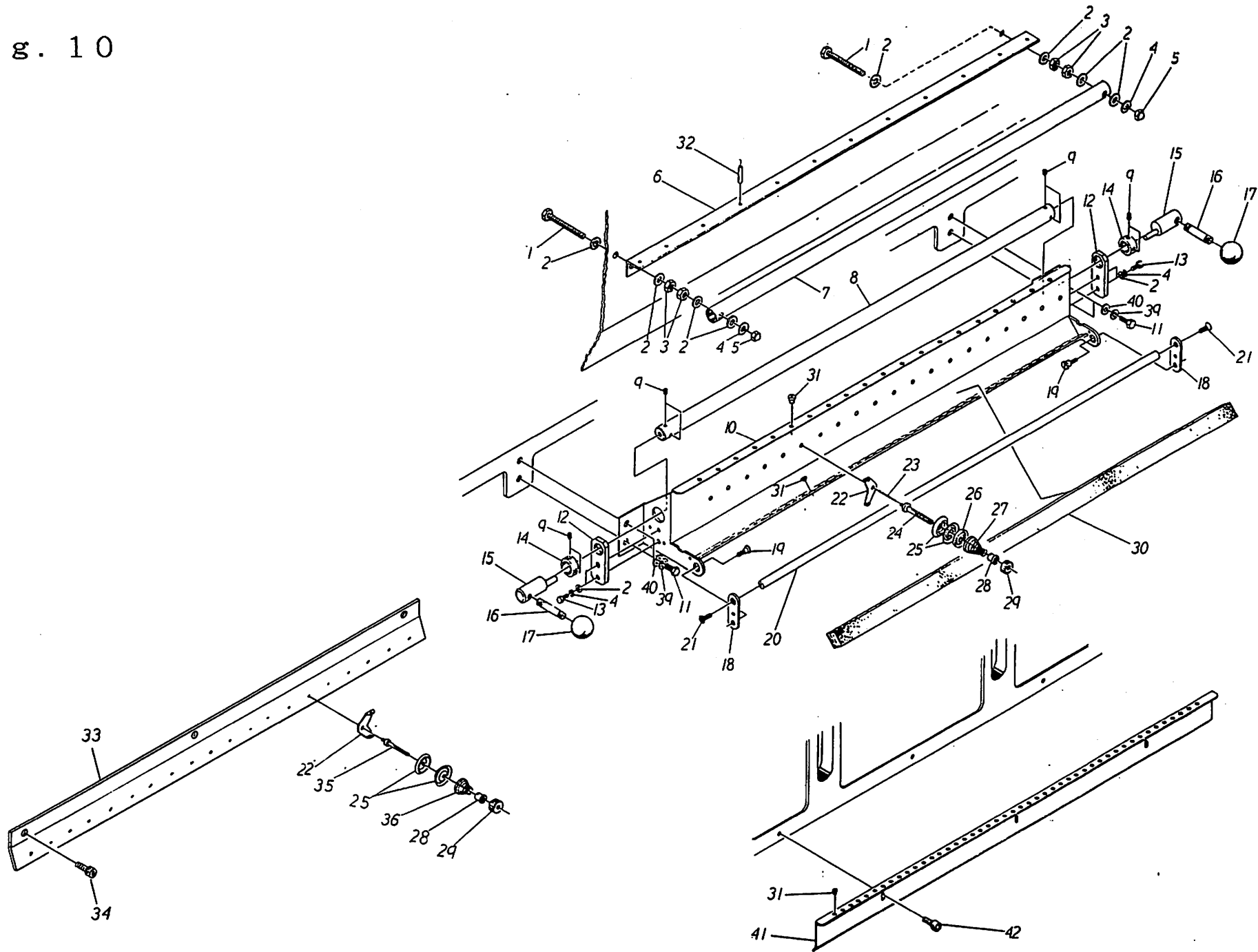

## DTN-552YP, 550YP, 552B

Fig.	NO.	Code	Name	Qty
10	1	5B45	Hexagon Head bolt 5x45	2
10	2	5W	Washer 5mm	32
10	3	5N	Nut 5mm	24
10	4	5SW	Spring washer 5mm	16
10	5	5NF	Cup nut 5mm	2
10	6	MT 115	Upper Thread pipe base	1
10	7	MT 136	Tension pipe	1
10	8	MT 96	Thread releasing shaft	1
10	9	5S4	Hexagon socket set screw 5x4	8
10	10	MT 95	Upper thread tension base	1
10	11	6B15	Hexagon Head bolt 6x15	4
10	12	MT 97	Thread releasing bearing	2
10	13	5B12	Hexagon Head bolt 5x12	4
10	14	D 143	Collar 15x25-10	2
10	15	MT 98	Eccentric pin	2
10	16	MF 739	Feed roller adjust handle	2
10	17	IM-15-5	Knob PC25-8	2
10	18	MT 100	Thread presser link	2
10	19	N 351	Shoulder bolt 8x5	2
10	20	MT 99	Thread presser shaft	1
10	21	4F8	Flat head screw 4x8	2
10	22	MT 30	Tension disk thread guide	24
10	23	MT 138	Thread tension releasing pin	12
10	24	MT 195	Tension bar	12
10	25	MT 25-1	Tension disk	48
10	26	MT 137	Tension releasing disk	12
10	27	J 195	Tension spring 1.0-19x21	12
10	28	MT 23-1	Tension collar	24
10	29	MT 22-1	Tension Nut	24
10	30	E20-590	Felt	1
10	31	IM-25-01	Thread guide GP-S	108
10	32	MT 109	Thread guide pipe	12
10	33	MT 234	Lower thread tension base	1
10	34	6K10	Hexagon socket head screw 6x10	5
10	35	MT 29	Tension bar	12
10	36	J 170	Tension spring 0.6-19x21	12
10	39	6SW	Spring washer 6mm	9
10	40	6W	Washer 6mm	9
10	41	MT 118	Upper thread guide	1
10	42	5K10	Hexagon socket head screw 5x10	3

Fig. 11

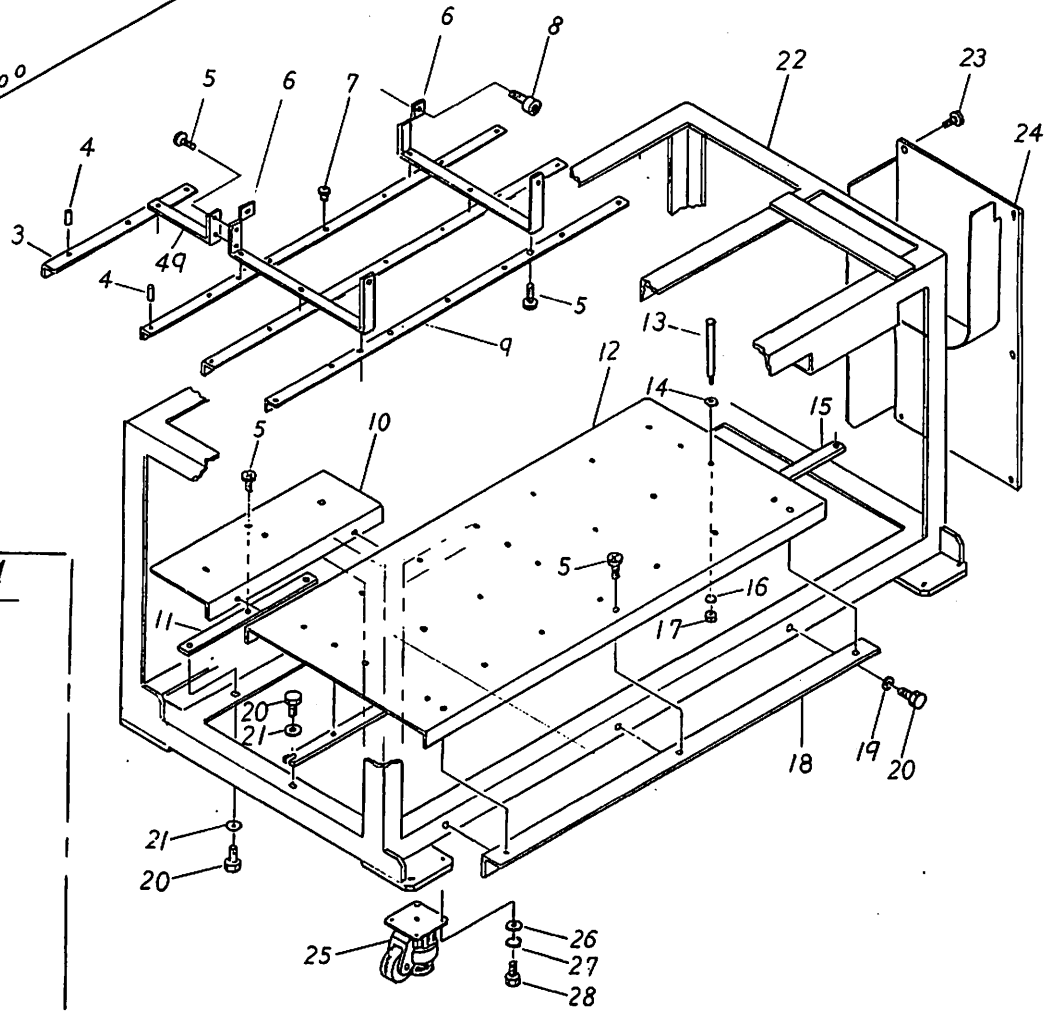
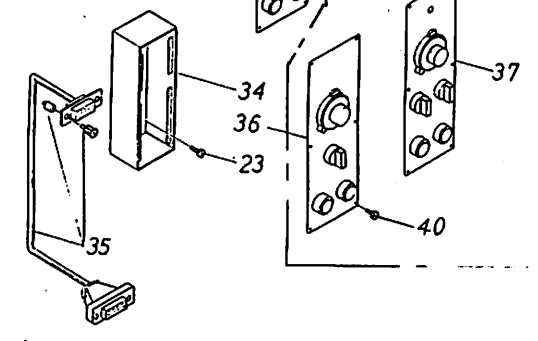
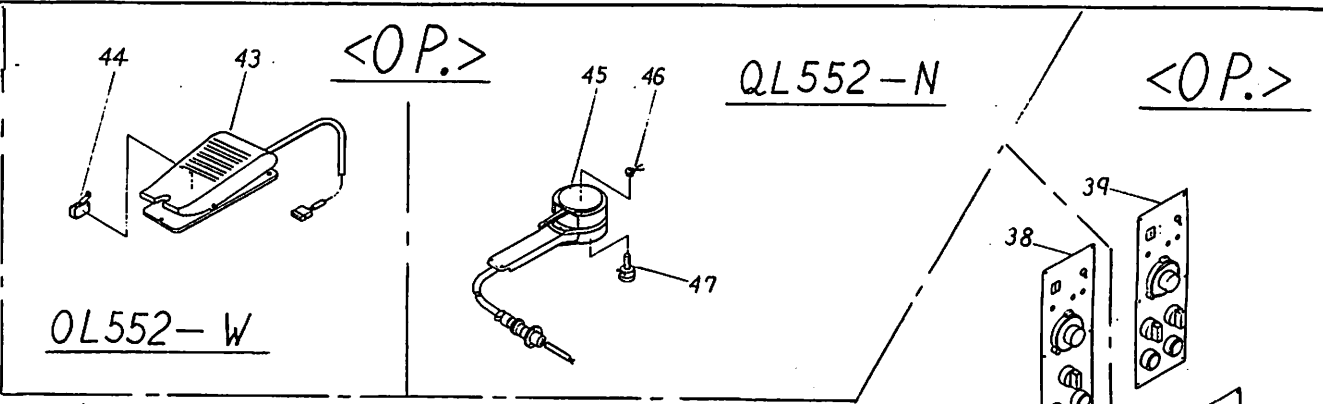
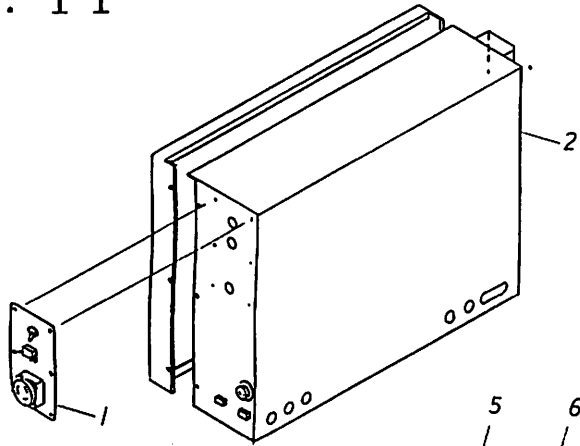

QL552-E1~E4

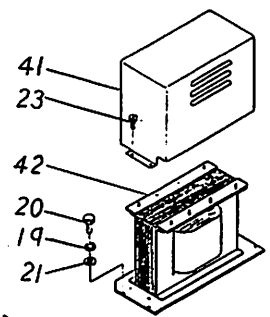

<OP.>

QL552-T1, T2

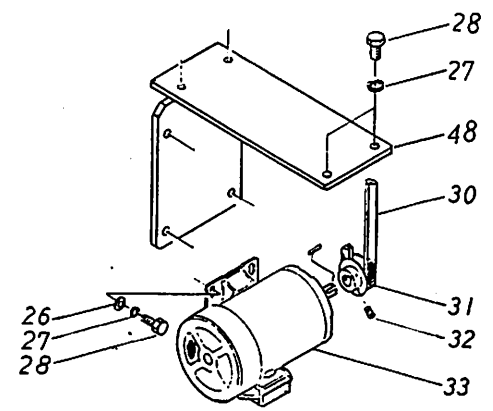

## DTN-552YP, 550YP, 552B

Fig. NO.	Code.	Name.	Q'ty
11	1	MX 120-1 Receptacle panel Unit	1
11	2	ME 40-1 Control box Unit	1
11	3	SKZWA502 Upper thread guard	1
11	4	MT 109 Thread guide pipe	12
11	5	5TB Truss head screw 5x8	15
11	6	XZDVA504 Lower thread guard base	2
11	7	IM-25-01 Thread guide GP-S	12
11	8	5K10 Hexagon socket head screw 5x10	4
11	9	MT 161 Thread guard	3
11	10	XZQWA507 Upper thread spool holder base	1
11	11	BCHJB506 Upper thread spool holder base bracket	1
11	12	XZWA502 Lower thread spool holder base	1
11	13	MT 19-1 Spool pin	24
11	14	5W Washer 5mm	24
11	15	BCHQB506 Lower thread spool holder base bracket A	1
11	16	5SW Spring washer 5mm	24
11	17	5N Nut 5mm	24
11	18	BIKOB503 Lower thread spool holder base bracket B	1
11	19	6SW Spring washer 6mm	3
11	20	6B15 Hexagon Head bolt 6x15	3
11	21	6W Washer 6mm	4
11	22	XVYYA003 Stand	1
11	23	4T8 Truss head screw 4x8	5
11	24	XWYYA502 Belt cover	1
11	25	IM-03-16 Caster CS-1	4
11	26	8W Washer 8mm	16
11	27	8SW Spring washer 8mm	20
11	28	8B15 Hexagon Head bolt 8x15	24
11			
11	30	IM-20-20 V-belt A-35 (DTN-552YP, 550YP)	1
11	30	IM-20-21 V-belt A-39 (DTN-552B)	1
11	31	V 321 V-Pulley 2.5A1-19 (DTN-552YP, 550YPF)	1
11	31	V 240-1 V-Pulley 4A1-24 (DTN-552B)	1
11	32	6S8 Hexagon socket set screw 6x8	2
11	33	IE-31-20 Motor SF-JR 3P, 0.75K, 4Pole (DTN-552YP, 550YPF)	1
11	33	IE-31-21 Motor SF-JR 3P, 1.5K, 4Pole (DTN-552B)	1
11	34	ME 46 Control box Unit	1
11	35	KUMA 0037 Cable unit	1
11	36	ME 47-1 Operation panel Unit	1
11	37	ME 48-1 Operation panel Unit (QL552-S)	1
11	38	ME 49-1 Operation panel Unit (QL552-F)	1
11	39	ME 50-1 Operation panel Unit (QL552-S, F)	1
11	40	3P6 Cross recessed head screw 3x6	6
11	41	XNSWA502 Transformer cover	1
11	42	E7030 Transformer 480v/200v-3KVA (QL552-E2)	1

## DTN-552YP, 550YP, 552B

Fig. NO.	Code.	Name.	Q'ty
11	42	E7032 Transformer 240v/200v-3KVA (QL552-E1)	1
11	42	E7031 Transformer 480v/200v-4.5KVA (QL552-E4)	1
11	42	E7033 Transformer 240v/200v-4.5KVA (QL552-E3)	1
11	43	ME 16 Foot switch unit (QL552-W)	1
11	44	V10-1A Micro-switch V10-1A	1
11	45	ME 17 Inching unit (QL552-N)	1
11	46	J 159 Kick spring 1.1-9x3.3	1
11	47	IE-29-03 Volume RV24YN-B10K	1
11	48	XFQSA501 Motor base (DTN-552YP, 550YP)	1
11	48	XFRSA501 Motor base (DTN-552B)	1
11	49	XZDQA503 Upper thread guard base	1

Fig. 12

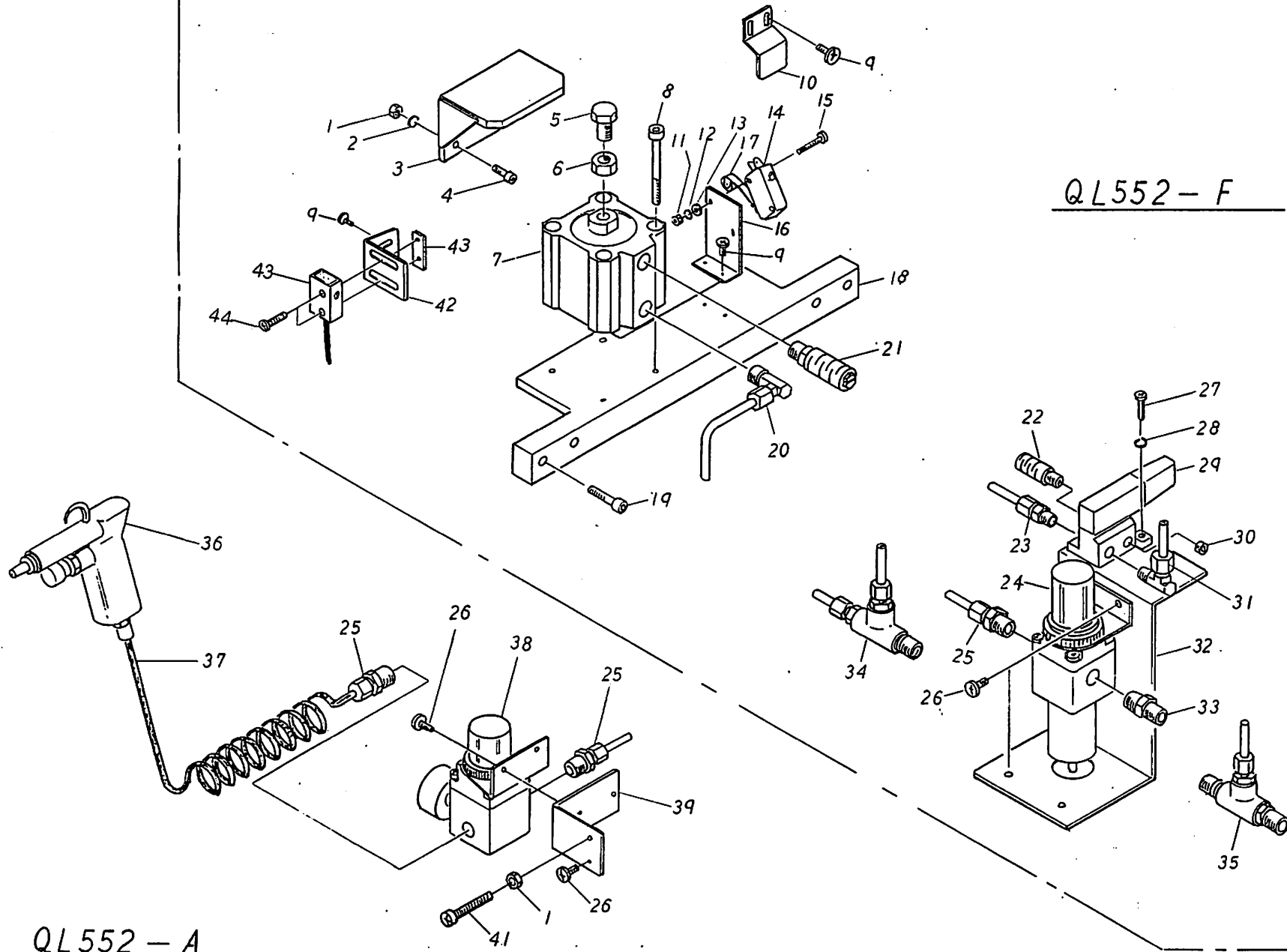

## DTN-552YP, 550YP, 552B

Fig.	NO.	Code.	Name.	Q'ty
12	1	5N	Nut 5mm	3
12	2	5SW	Spring washer 5mm	3
12	3	MP 61	Presser lift base	1
12	4	5K20	Hexagon socket head screw 5x20	3
12	5	10B15	Hexagon Head bolt 10x15	1
12	6	10N6	Nut 10mm-6	1
12	7	1A-05-28	Air cylinder CQ1B50-30	1
12	8	6K60	Hexagon socket head screw 6x60	4
12	9	4T8	Truss head screw 4x8	4
12	10	MP 62	Switch trip	1
12	11	3N	Nut 3mm	2
12	12	3SW	Spring washer 3mm	2
12	13	3W	Washer 3mm	2
12	15	3P18	Cross recessed head screw 3x18	2
12	16	ME 15	Switch base	1
12	17	VAM22	Actuator VAM22	1
12	18	MP 60	Cylinder base	1
12	19	6K30	Hexagon socket head screw 6x30	4
12	20	1A-10-06	Elbow union DL06-02	1
12	21	1A-03-02	Silencer SLW-8A	1
12	22	1A-03-01	Silencer SLW-6A	1
12	23	1A-10-20	Half union H06-01	1
12	24	1A-13-06	Filter regulator AW2000-02BG	1
12	25	1A-10-21	Half union H06-02	1
12	26	5T8	Truss head screw 5x8	2
12	27	4P12	Cross recessed head screw 4x12	2
12	28	4SW	Spring washer 4mm	2
12	29	1A-11-17	Solenoid valve VZ3140-5G-01 DC24v	1
12	30	1A-10-18	Plug PF1/8	1
12	31	1A-10-19	Elbow union DL06-01	1
12	32	XZNR4501	Regulator mounting base	1
12	33	1/4N	Nipple	1
12	34	1/4T	Tee unit (QL552-A)	1
12	35	1/4T	Tee unit (OCT-552F)	1
12	36	K60	Air gun K60	1
12	37	1A-09-01	Coil tube TCU0604	1
12	38	1A-13-10	Regulator AR2000-02BG	1
12	39	XZGLA508	Regulator base	1
12	41	5P40	Cross recessed head screw 5x40	1
12	42	ME 45	Sensor base	1
12	43	GS-20	Sensor GS-20	1
12	44	3P15	Cross recessed head screw 3x15	2

Fig. 13

Optional parts

QL552-H12, H18, H21

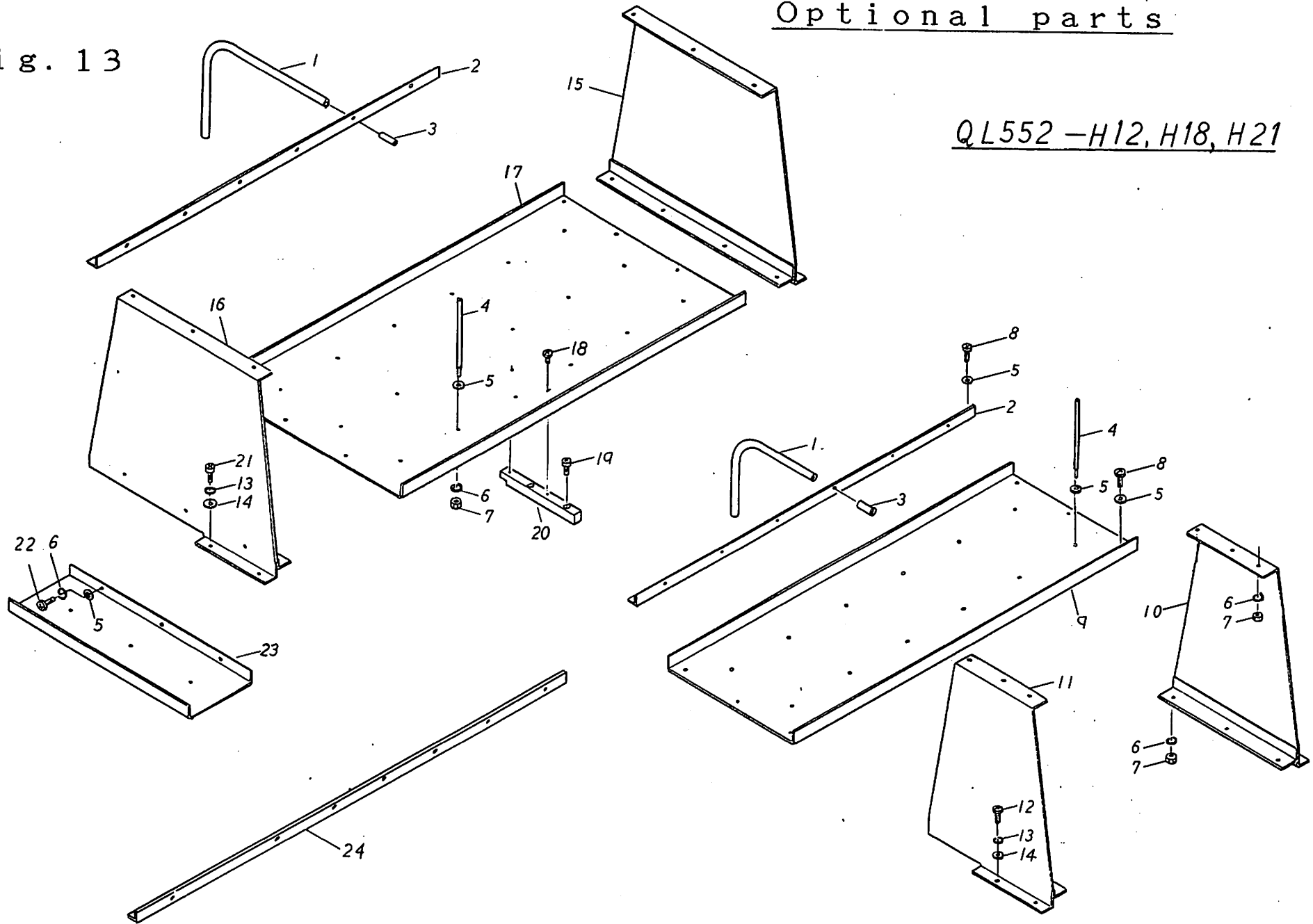

DTN-552YP, 550YP, 552B

Fig.	NO.	Code	Name	Q'ty
13	1	JIS4	Thread hose (QL552-H12)	12
13	1	JIS4	Thread hose (QL552-H18)	18
13	1	JIS4	Thread hose (QL552-H21)	21
13	2	MT 148	Upper thread guard (QL552-H12)	2
13	2	MT 148	Upper thread guard (QL552-H18)	3
13	3	MT 109	Thread guide pipe (QL552-H12)	12
13	3	MT 109	Thread guide pipe (QL552-H18)	18
13	3	MT 109	Thread guide pipe (QL552-H21)	21
13	4	MT 19-1	Spool pin (QL552-H12)	12
13	4	MT 19-1	Spool pin (QL552-H18)	18
13	4	MT 19-1	Spool pin (QL552-H21)	21
13	5	5W	Washer 5mm (QL552-H12)	22
13	5	5W	Washer 5mm (QL552-H18)	32
13	5	5W	Washer 5mm (QL552-H21)	35
13	6	5SW	Spring washer 5mm (QL552-H12)	22
13	6	5SW	Spring washer 5mm (QL552-H18)	32
13	6	5SW	Spring washer 5mm (QL552-H21)	35
13	7	5N	Nut 5mm (QL552-H12)	22
13	7	5N	Nut 5mm (QL552-H18)	32
13	7	5N	Nut 5mm (QL552-H21)	35
13	8	5P12	Cross recessed head screw 5x12	10
13	9	MT 146	Upper thread spool holder base (QL552-H12)	1
13	10	MT 147R	Thread spool holder side panel, Right (QL552-H12)	1
13	11	MT 147L	Thread spool holder side panel, Left (QL552-H12)	1
13	12	4P10	Cross recessed head screw 4x10	4
13	13	4SW	Spring washer 4mm	4
13	14	4W	Washer 4mm	4
13	15	MT 181R	Thread spool holder side panel, Right (QL552-H18, 21)	1
13	16	MT 181L	Thread spool holder side panel, Left (QL552-H18, 21)	1
13	17	MT 180	Upper thread spool holder base (QL552-H18, 21)	1
13	18	5T8	Truss head screw 5x8	2
13	19	5K10	Hexagon socket head screw 5x10	2
13	20	MT 231	Thread spool holder base support (QL552-H18, 21)	1
13	21	4K10	Hexagon socket head screw 4x10	4
13	22	5P8	Cross recessed head screw 5x8	3
13	23	MT 240	Auxiliary thread spool holder base (QL552-H21)	1
13	24	MT 140-1	Upper thread guard (QL552-H21)	3

QL552-C

Fig. 14

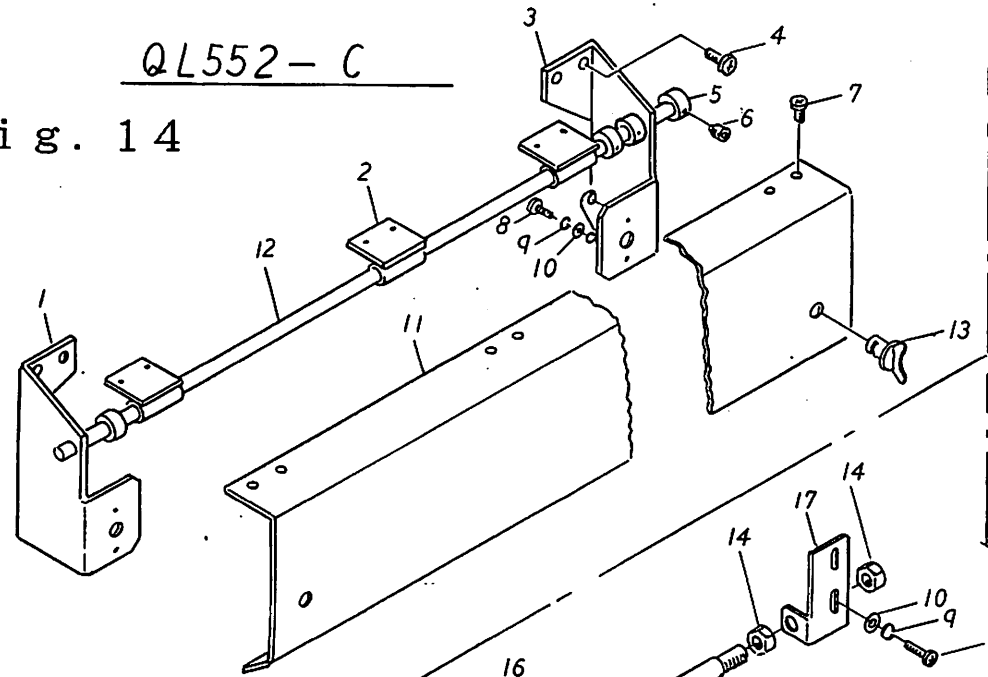

QL552-B

<OP.>

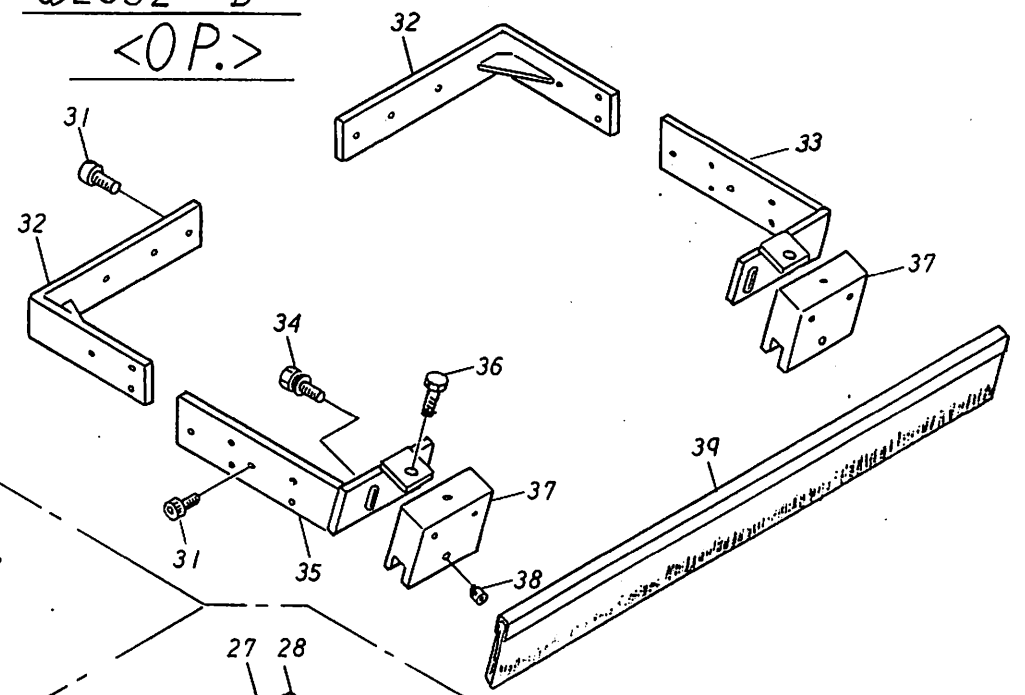

<OP.>

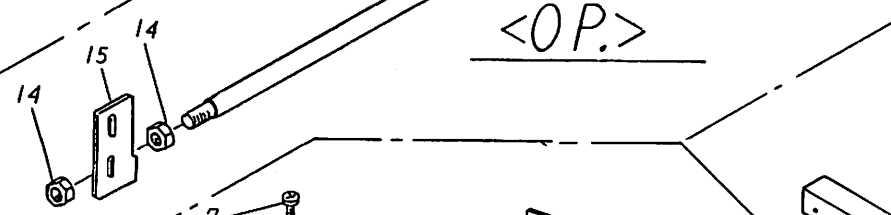

QL552-G

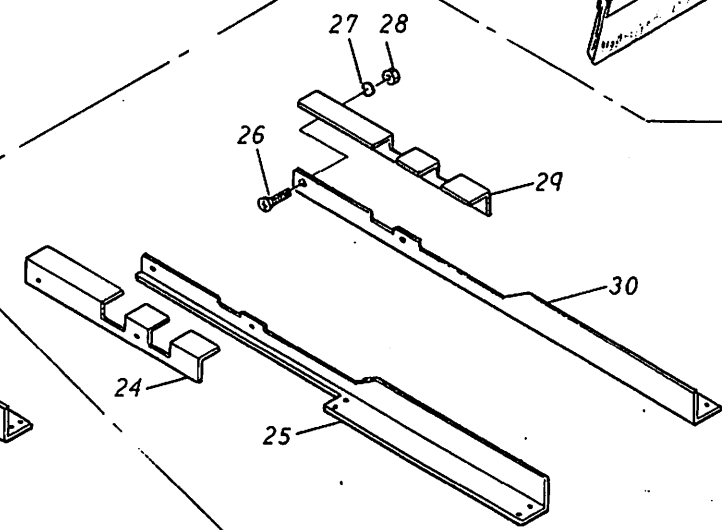

<OP.>

## DTN-552YP, 550YP, 552B

Fig.	NO.	Code.	Name.	Q'ty
14	1	MX 102L	Front cover base, Left (DTN-552YP, 550YP)	1
14	1	XZLPA514	Front cover base, Left (DTN-552B)	1
14	2	MX 49	Front cover mounting base	1
14	3	MX 102R	Front cover base, Right (DTN-552YP, 550YP)	1
14	3	XZLPA513	Front cover base, Right (DTN-552B)	1
14	4	5T8	Truss head screw 5x8	4
14	5	D 115	Collar 8x16-8	4
14	6	5S5	Hexagon socket set screw 5x5	8
14	7	4T8	Truss head screw 4x8	6
14	8	3P6	Cross recessed head screw 3x6	4
14	9	3SW	Spring washer 3mm	4
14	10	3W	Washer 3mm	4
14	11	MX 103	Front covar (DTN-552YP, 550YP)	1
14	11	XWPYA502	Front covar (DTN-552B)	1
14	12	B 662	Shaft 8x780L (DTN-552YP, 550YP)	1
14	12	BDDOA502	Shaft 8x790L (DTN-552B)	1
14	13	C61-1A	Fastner C61-1A	2
14	14	8N	Nut 8mm	4
14	15	MX 245L	Guard mounting base, Left	1
14	16	MX 246	Guard bar	1
14	17	MX 245R	Guard mounting base, Right	1
14	18	3P10	Cross recessed head screw 3x10	4
14	19	MX 56	Guide clamp	4
14	20	MX 58	Clamp disk	4
14	21	MX 57	Clamp screw	4
14	22	MX 55L	Guide, Left	1
14	23	MX 55R	Guide, Right	1
14	24	MB 204	Upper guide, Left	1
14	25	MB 202	Side guide, Left	1
14	26	4F10	Flat head screw 4x10	4
14	27	4SW	Spring washer 4mm	4
14	28	4N	Nut 4mm	4
14	29	MB 203	Upper guide, Right	1
14	30	MB 201	Side guide, Right	1
14	31	6K15	Hexagon socket head screw 6x15	10
14	32	MF 277	Belt Feed roller base	2
14	33	MF 296R	Brush base, Right	1
14	34	6B15SW	Hexagon Head bolt 6x15SW	4
14	35	MF 296L	Brush base, Left	1
14	36	6B25	Hexagon Head bolt 6x25	2
14	37	MF 295	Brush mounting base	2
14	38	6S6	Hexagon socket set screw 6x6	2
14	39	MF 294	Brush	1

Fig. 15

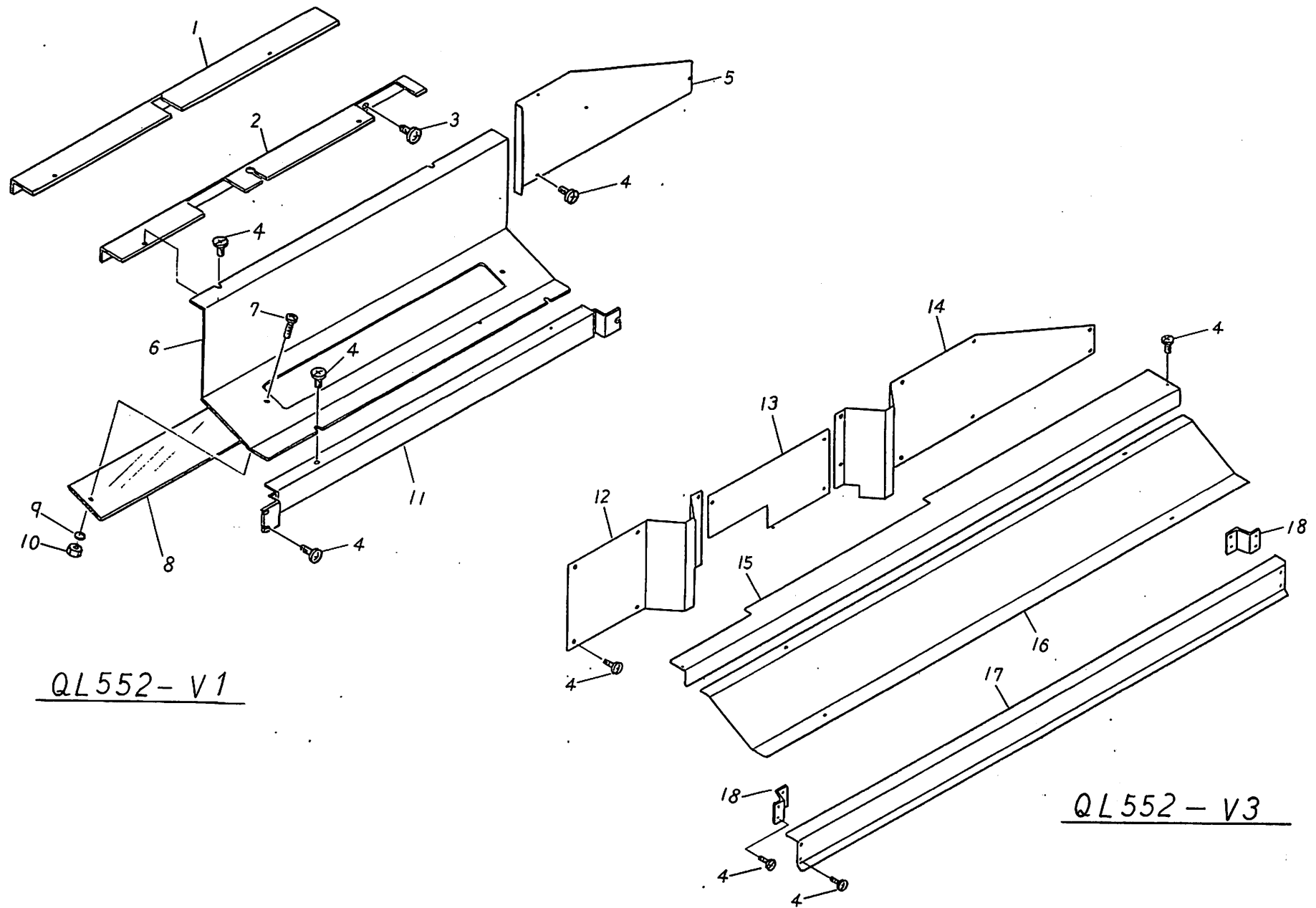

QL552-V1

QL552-V3

## DTN-552YP, 550YP, 552B

Fig.	NO.	Code.	Name.	Q'ty
15	1	MX 297	Rear cover mounting plate (DTN-552B)	1
15	2	MX 292	Rear cover mounting plate (DTN-552YP)	1
15	3	5T8	Truss head screw 5x8	3
15	4	4T8	Truss head screw 4x8	8
15	5	MX 296	Rear side cover	1
15	6	MX 293	Rear cover	1
15	7	4P10	Cross recessed head screw 4x10	11
15	8	MX 204	Rear cover, Lower	1
15	9	4SW	Spring washer 4mm	2
15	10	4N	Nut 4mm	2
15	11	MX 295	Roller cover	1
15	12	MX 104	Rear cover, Right	1
15	13	MP 71	Cylinder cover	1
15	14	MX 105	Rear cover, Left	1
15	15	MX 51	Feed roller cover base	1
15	16	MX 50	Feed roller cover	1
15	17	MX 52	Feed roller cover base, Lower	1
15	18	MX 53	Cover base mounting plate	2

Fig. 16

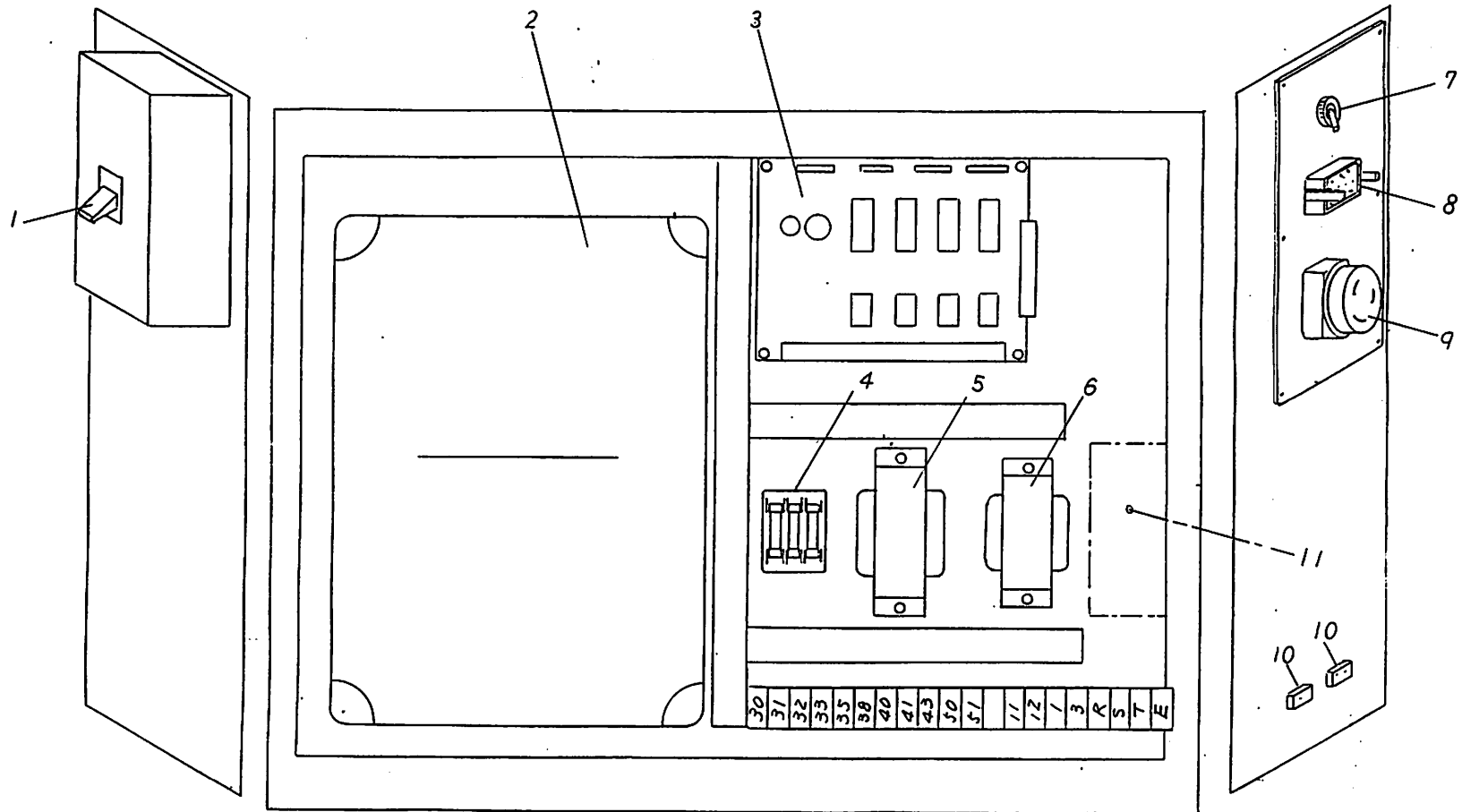

## DTN-552YP, 550YP, 552B

Fig. NO.	Code.	Name.	Q'ty
16	1	IE-26-01 Contact breaker NF30GD-3P-30A	1
16	2	IE-01-03 Inverter FR-Z220-0.75K (DTN-552YP, 550YP)	1
16	2	IE-01-04 Inverter FR-Z220-1.5K (DTN-552B)	1
16	3	QMA-X01 P. C. B. QMA-x01	1
16	4	1A Cartridge fuse 1A	2
16	4	3A Cartridge fuse 3A	1
16	5	SR-100L Transformer SR-100L	1
16	6	SD-181B Transformer SD-181B	1
16	7	AJ111101 Toggle swich AJ111101	1
16	8	1-171197-0 Nylon connector 1-171197-0 (9P)	1
16	9	WK2315k Receptacle	1
16	10	1-48034-0 Nylon connector 1-48034-1 (3P)	1
16	11	MSO-K10 Magnetic swich MSO-K10 0.2KW (QL552-S)	1

Fig. 17

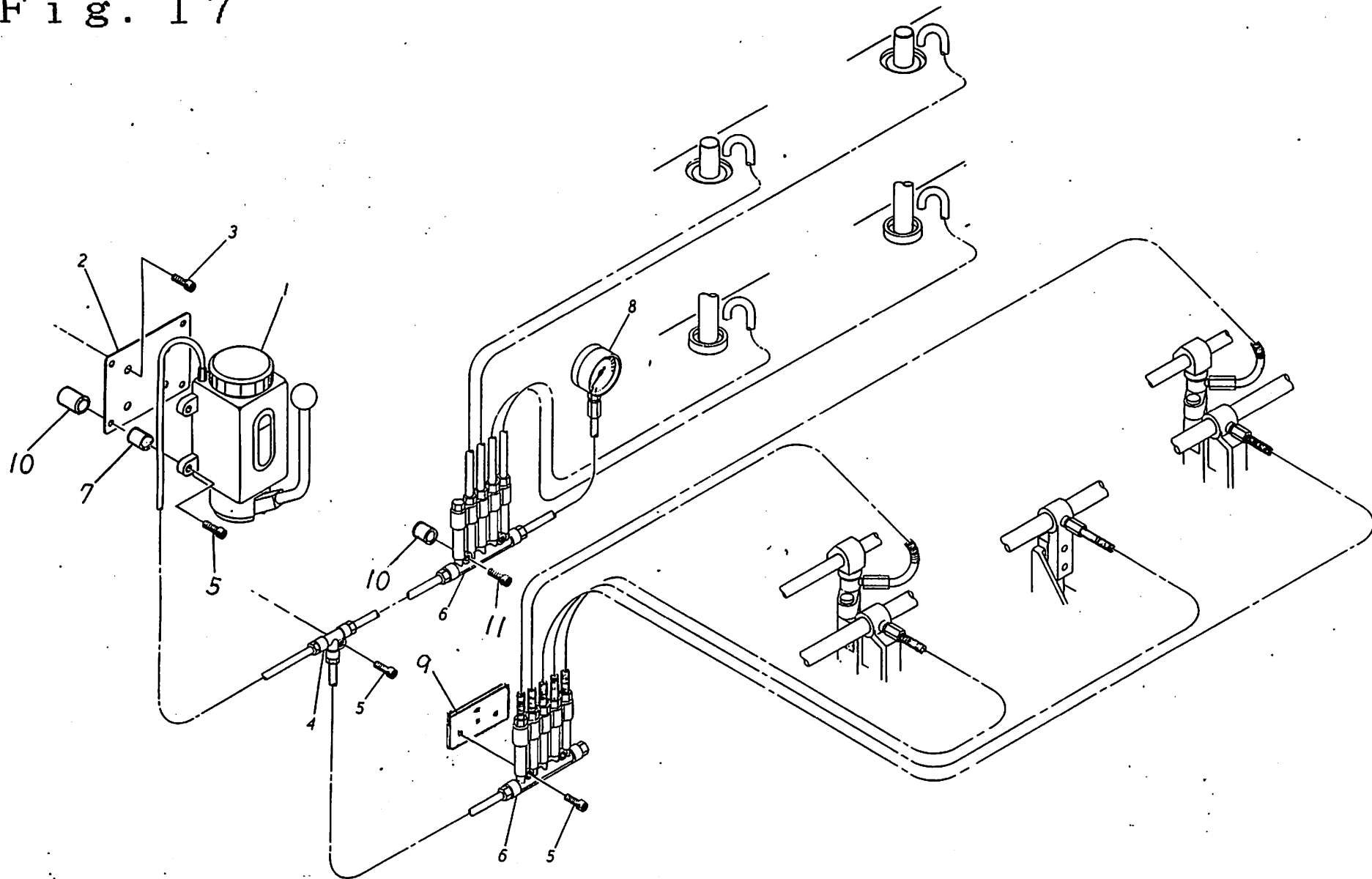

DTN-552YP, 550YP, 552B

Fig.	NO.	Code.	Name.	Q'ty
17	1	LAW6	Oil pump	1
17	2	MO 5	Oil pump base	1
17	3	6K25	Hexagon socket head screw 6x25	4
17	4	PKD4	Three way type PKD4	1
17	5	6K20	Hexagon socket head screw 6x20	7
17	6	DPB25-0.2	Plunger pump DPB25-0.2	2
17	7	W 198	Ring 6x10-8	4
17	8	PGL35	Pressure gauge PGL35	1
17	9	MO 7	Lower Plunger Pump base	1
17	10	W 327	Ring 6x10-14	8
17	11	6K40	Hexagon socket head screw 6x40	2

Fig. 18

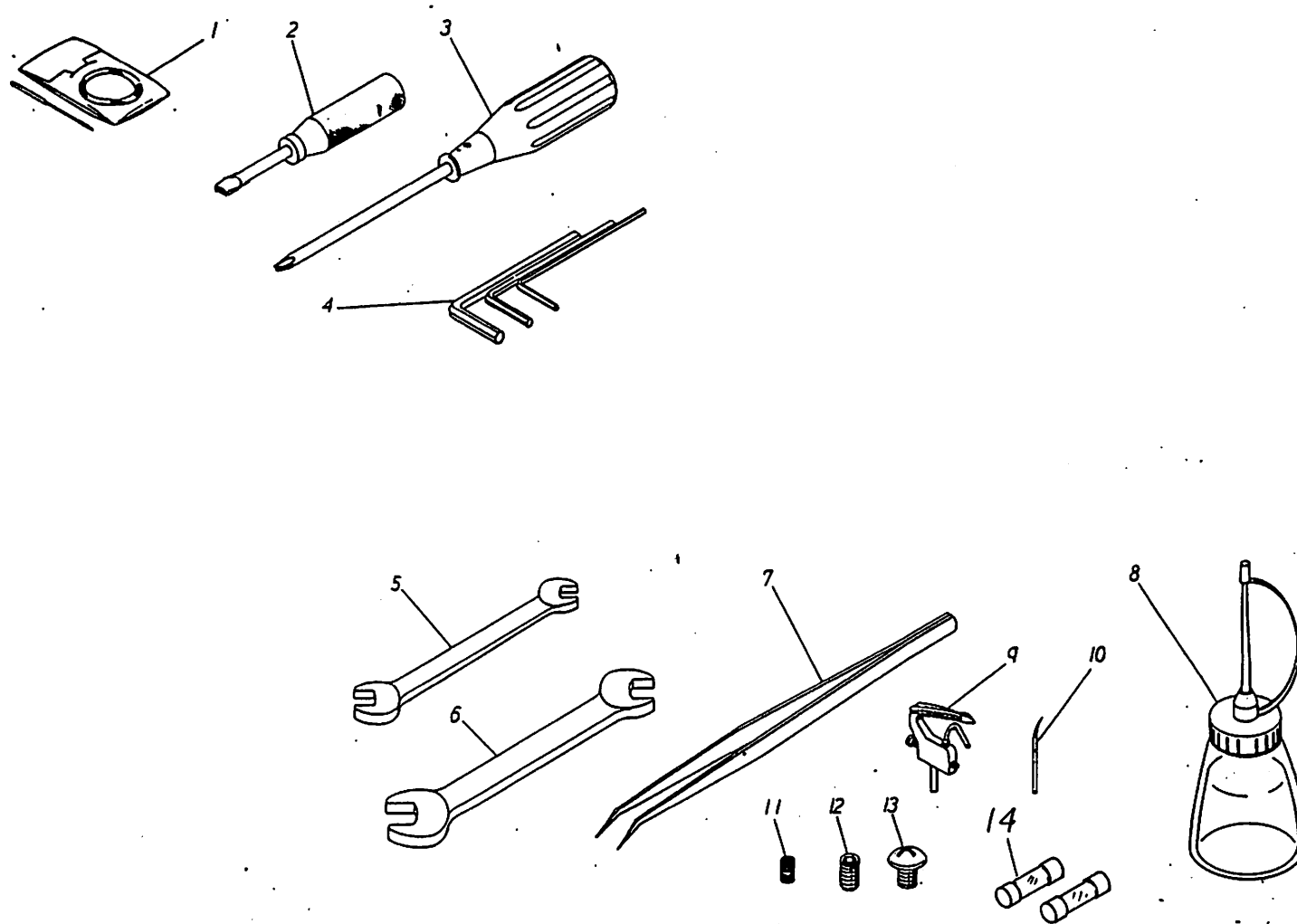

DTN-552YP, 550YP, 552B

Fig.	NO.	Code.	Name.	Q'ty
18	1	DVx600	Needle DVx600 #23	10
18	2	SD3-M	Stubby driver (-)	1
18	3	P1-75	Screw driver (+)	1
18	4	SCM-1.27	Hexagon socket driver 1.27mm	1
18	4	SCM-1.5	Hexagon socket driver 1.5mm	1
18	4	SCM-2.0	Hexagon socket driver 2.0mm	1
18	4	SCM-2.5	Hexagon socket driver 2.5mm	1
18	4	SCM-3.0	Hexagon socket driver 3.0mm	1
18	4	SCM-5.0	Hexagon socket driver 5.0mm	1
18	4	SCM-6.0	Hexagon socket driver 6.0mm	1
18	4	SCM-4.0	Hexagon socket driver, Long 4.0mm	1
18	5	JIS8-10	Socket spanner 8x10	1
18	6	JIS13-17	Socket spanner 13x17	1
18	7	PIN-BE150	Tweezers	1
18	8	P-01L100	Oil	1
18	9	ML 20	Looper	1
18	10	ML 3556	Thread unraveller	1
18	11	3S6	Hexagon socket set screw 3x6	5
18	12	4S8	Hexagon socket set screw 4x8	5
18	13	4T8	Truss head screw 4x8	5
18	14	1A	Cartridge fuse 1A	1
18	14	3A	Cartridge fuse 3A	1