

FINEST QUALITY

STYLE
2800 E-2

CATALOG
No.
501A

Union Special[®]

AUTOMATED SYSTEMS

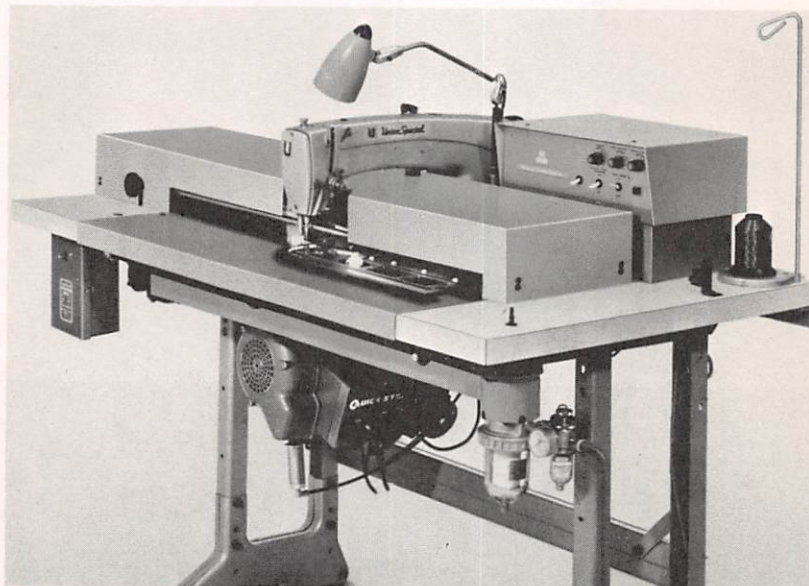

INSTRUCTIONS
AND
PARTS LIST
FOR
TROUSER FLY SEWING STATION

Union Special[®] CORPORATION

FOREWORD

This technical manual has been prepared in the STEP* format. The procedures provide the information needed to do a particular job in illustrated, easy to follow steps. No figure numbers are used in this format, and the illustrations are never referenced in the text – The illustration is always next to the text it supports, so no figure numbers or references are needed.

The electrical portion of the TROUBLESHOOTING section provides the information needed to define malfunctions in the 2800 E-2 Trouser Fly Sewing Station, and to determine "probable failures" causing such malfunctions.

An INDEX OF MALFUNCTIONS is provided to allow you to refer to the procedure needed to troubleshoot a particular problem. To use the manual to troubleshoot a malfunctioning Trouser Fly Sewing Station refer to the INDEX OF MALFUNCTIONS and locate the malfunction description that most nearly matches the problem. The INDEX OF MALFUNCTIONS lists the malfunctions covered in the TROUBLESHOOTING section, and gives the page number on which each procedure begins.

Each STEP* troubleshooting procedure is presented in a logic sequence flowchart, or "bubble chart" which outlines the entire troubleshooting procedure. Each "bubble" of the flow chart contains a statement of an action to be taken, and the arrangement of the bubbles in the chart shows the order in which these actions are to be taken. Each bubble also has a code letter which keys it to a series of illustrated steps which describe how to perform that action. The flow lines leading out of each bubble show which action to perform next and how to interpret the results of the action just taken.



Developed by



570 Seventh Avenue, New York, New York 10018

FOR

Union Special[®]
CORPORATION

Catalog No. 501 A

INSTRUCTIONS

FOR

ADJUSTING AND OPERATING

LEFT TROUSER FLY SEWING STATION

2800 E-2

FIRST EDITION

Copyright 1973
By
Union Special Corporation
Chicago, Ill.

Rights Reserved in All Countries

May, 1973

Printed in U.S.A.

CONTENTS

Section	Title	Page
I	GENERAL INFORMATION	1
	A. Operation	1
	B. Specifications	2
II	INSTALLATION AND PRE-OPERATING INSTRUCTIONS	3
	A. Inspection	3
	B. Check Machine Head	3
	C. Check Drive Cable	3
	D. Check Needle Alignment	3
	E. Check Oil	3
	F. Check Rotation of Sewing Head	4
	G. Installation	4
	H. Operation	5
	I. Stand-Up Installation	6
III	OPERATOR INSTRUCTIONS	9
	A. Operating Hints	9
	B. Machine Care	9
	C. Sequence of Operation	9
	Timing Chart	11
IV	DESCRIPTION AND ADJUSTMENT OF ELECTRICAL CONTROLS	13
	A. Switches	13
	B. Carriage Return Control	14
	C. Photocell	14
	D. Stop Position Control	15
	E. Slow Speed Start Adjustment	15
	F. Clamp Raise Delay	15
	G. Backtack Length Control	15
	H. Bobbin Winder Control	16
	I. Pneumatic Controls	16
	J. Unit Mechanical Systems	16
	K. Sewing Head Adjustments	20
V	GENERAL MAINTENANCE	25
	A. Cleaning	25
	Lubrication	25
	Replacement	25
VI	PARTS LISTS	27
VII	SCHEMATICS	40
VIII	TROUBLESHOOTING	43

SECTION I
GENERAL INFORMATION

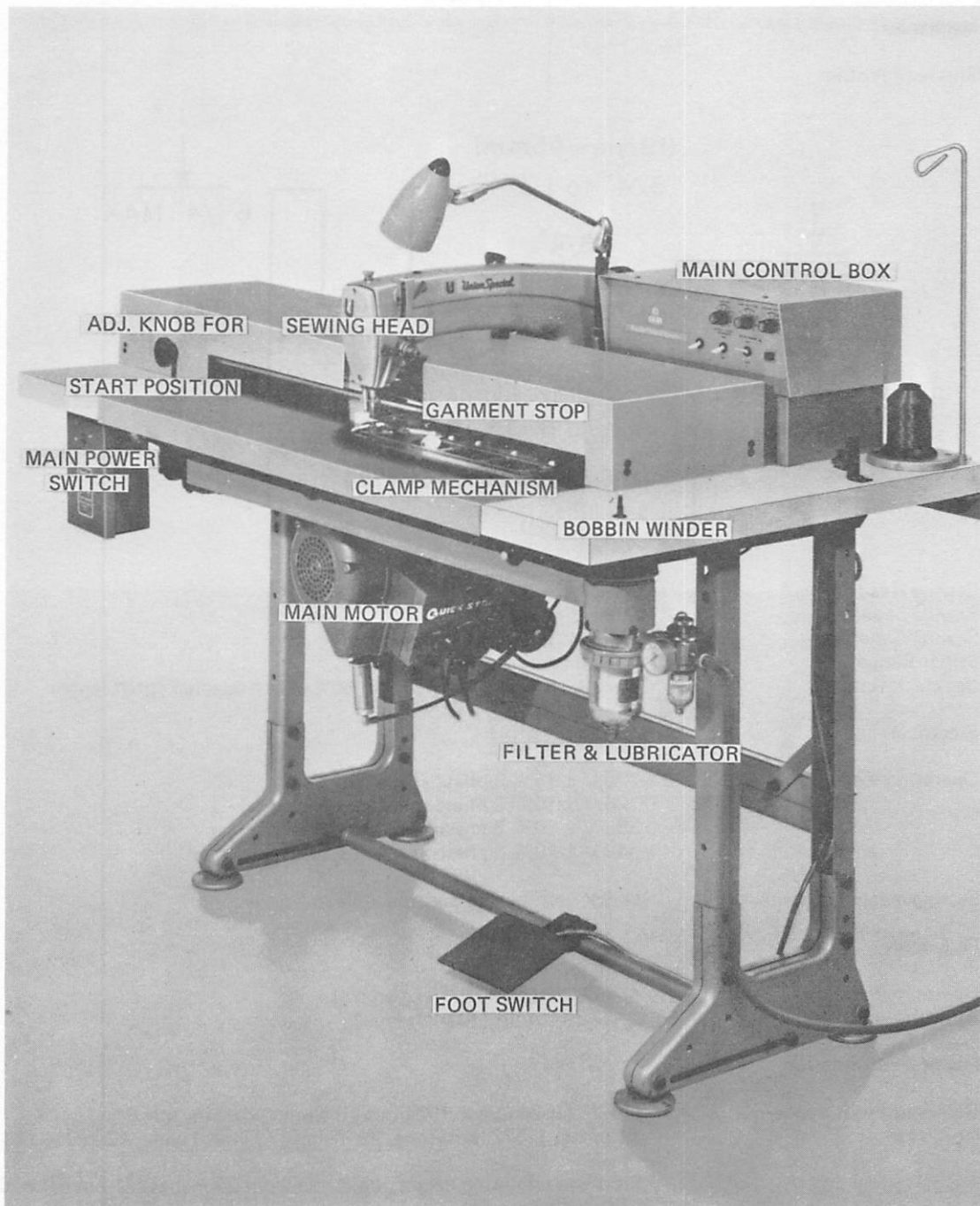

A. OPERATION

Load the pre-pressed fly and press the two position foot switch. The clamp will lower; the machine will sew to the pre-selected spot or end of the garment, stop, or backtack if required, and cut the threads. The clamp will then lift and return to the starting position.

B. SPECIFICATIONS

(1) Mechanical

Stitching Profile

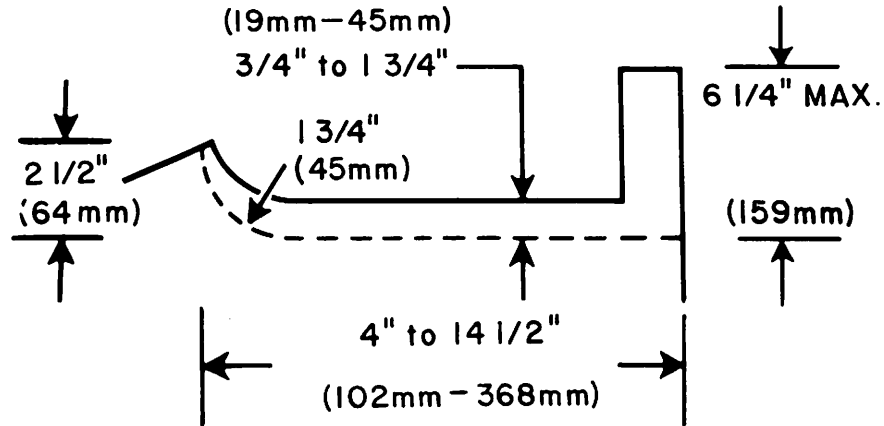

Sewing Head	63400 kbz
Sewing Speed	4000 rpm
Sewing Capacity	1/4 inch (6.4 mm) at waistband
Stitch Range	10–18 spi (2.5 mm–1.5 mm)
Backtack Range	0 to 10 stitches - stitch length 60% of pre-selected stitch length

(2) Electrical

Operating Voltage	220 V ± 15%, 3 phase at 6 amps, 60 Hz 220 V ± 10%, 3 phase at 7 amps, 50 Hz 380 V ± 10%, 3 phase at 5 amps, 50 Hz 440 V ± 10%, 3 phase at 4 amps, 50 Hz
-------------------	--

Sewing Machine Drive	Quick-Stop needle positioner electro-drive.
----------------------	---

(3) Pneumatic

Operating Pressure	45–55 psi (3.16–3.87 kg/sq cm)
Air Consumption	2-1/2 cu ft/min (70 liters/min)

(4) Physical Information

Required Floor Space	5' x 5' (1524 mm x 1524 mm) includes operator space
Unit Size	54 inches (1372 mm) long, 29 inches (737 mm) wide, 42 inches (1067 mm) high Sit down operating height adjustable from 28 inches (711 mm) to 32 inches (812 mm) Stand up operating height adjustable from 38 inches (965 mm) to 42 inches (1067 mm)
Shipping Weight	600 lbs (272 kgs)
Shipping Container	62 cu ft (1.76 cu m) 52 inches (1320 mm) high, 59 inches (1550 mm) long, 35 inches (890 mm) wide

SECTION II INSTALLATION AND PRE-OPERATING INSTRUCTIONS

A. INSPECTION

- (1) After uncrating the unit, make a visual inspection to check for any obvious damage. Place the unit in the work area. Level the unit in the normal manner.
- (2) Remove all shipping clamps and/or tape from the sewing head, clamp, motors, etc.

CAUTION

The following instructions must be followed to avoid damage to the unit.

B. CHECK MACHINE HEAD

- (1) Remove the two sheet metal covers from the unit. Check the bed position spring for shipping damage. Shake the machine to check for excessive motion of the head in the drip pan base. Movement should not exceed 1/64 inch: more than this amount will cause poor sewing because the needle will not be aligned in center of the clamp plate.

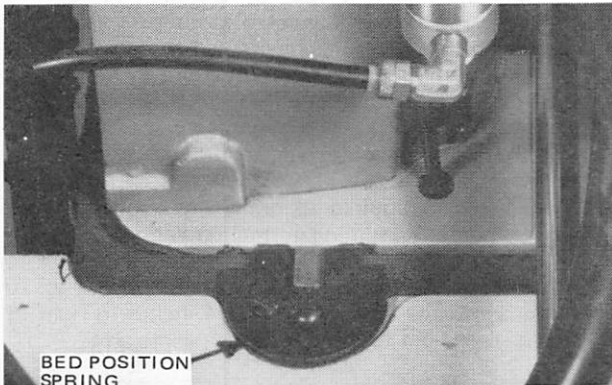

CHECK BED POSITION SPRING

C. CHECK DRIVE CABLE

- (1) Check that the drive cable is on the pulleys. Cable slack is taken up by loosening the hex head bolts of the idler pulley, with the clamp just past the curve position. Take up enough to remove the cable slack, but not enough to put extreme tension on the cable.

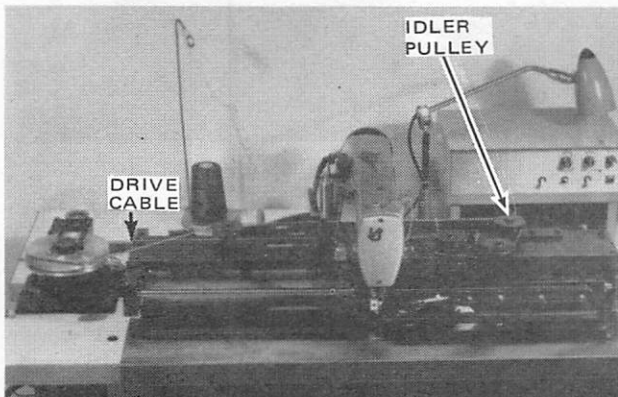

CHECK DRIVE CABLE

D. CHECK NEEDLE ALIGNMENT

- (1) Insert new needle and position needle bar down.
- (2) Raise the clamp slightly from the work surface and manually move it through its entire travel by rotating the left horizontal drive pulley. Carefully check that the needle is in the center of the clamp slot for the entire travel. If needle is not in center of slot, refer to Section IV, paragraph J4.

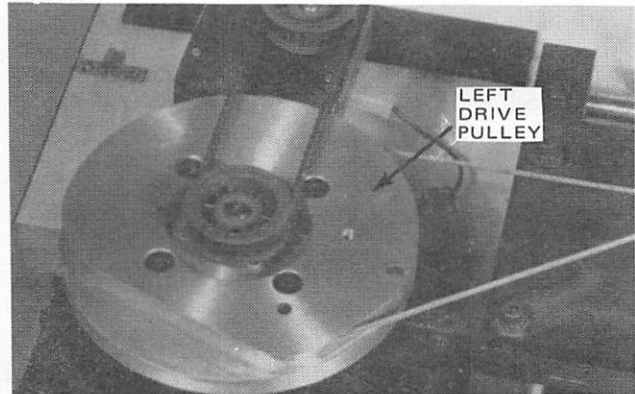

MANUALLY MOVE CARRIAGE

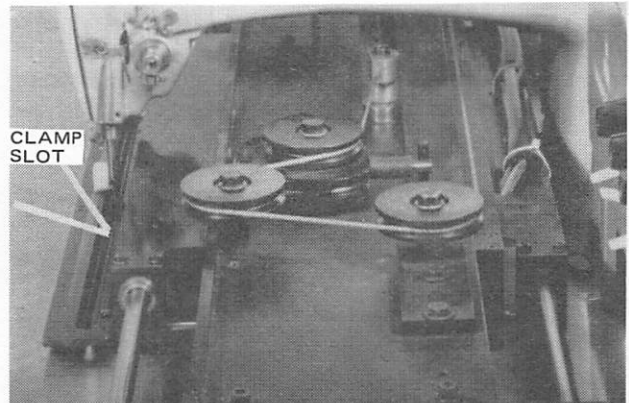

CHECK CLAMP ALIGNMENT

E. CHECK OIL

- (1) Check the oil level gauge in the sewing head and add oil if necessary.

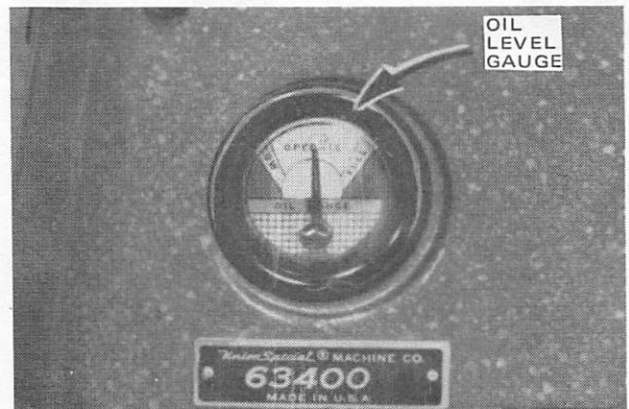

CHECK OIL LEVEL

F. CHECK ROTATION OF SEWING HEAD

- (1) Be sure air is not connected to unit.
- (2) Remove synchronizer plug from motor control panel.
- (3) Connect power supply to main switch box.
- (4) Turn main switch ON.
- (5) Manually depress clutch arm on main motor.
- (6) Proper rotation is clockwise looking from operator position.
- (7) If rotation is wrong, simply reverse any two of three incoming power supply lines to the unit main switch box.

G. INSTALLATION

CAUTION

The unit is properly grounded. Your outlet must be grounded to ensure adequate protection for the operator and the equipment.

- (1) Turn main power switch OFF and rotate hand-wheel (clockwise from the operator's position) until the needle thread takeup lever is $\frac{1}{8}$ inch below top of stroke.

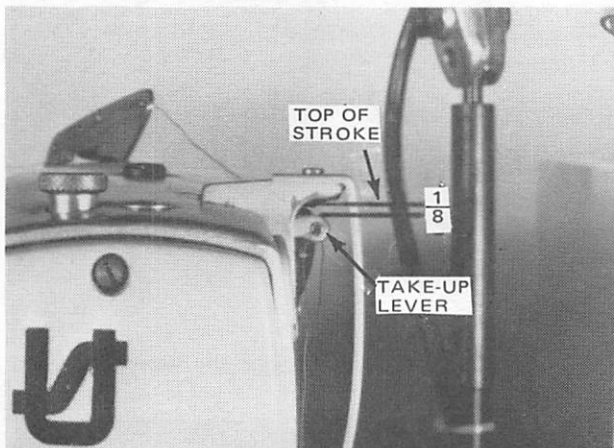

POSITION TAKE-UP LEVER

- (2) Be sure all plugs are plugged into the motor control panel. Turn both main and control box switches ON.
- (3) Add oil to the air lubricator per instructions in maintenance, Section VI. Connect the air supply line to the unit and adjust the regulator to 45 psi.

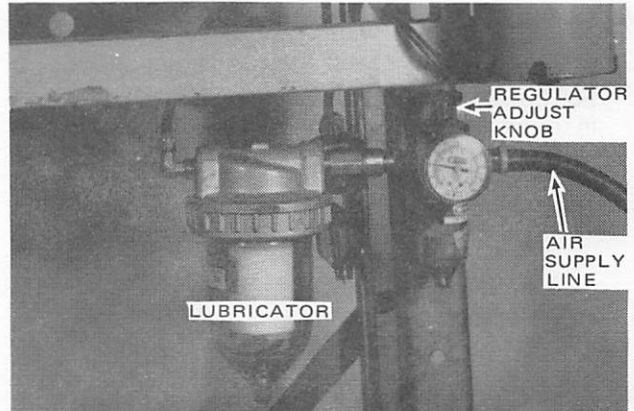

OIL LUBRICATOR AND CONNECT AIR SUPPLY

NOTE

Be sure the supply line has been purged of any contaminants and/or moisture before attaching to the unit. Also, observe the air filter bowl during the first half hour of operation to be sure no appreciable accumulation occurs. Accumulated moisture can be drained by depressing the plunger in the bottom of the air filter bowl. If the accumulation in the filter bowl is not removed, excessive oil and water will build up in control system, eventually causing malfunction. A considerable amount of time will then be required to drain and clean the system before resuming normal operation.

- (4) Locate the sewing light approximately 9 to 10 inches above the table and about 4 inches to right of needle. Turn light to illuminate the needle area.

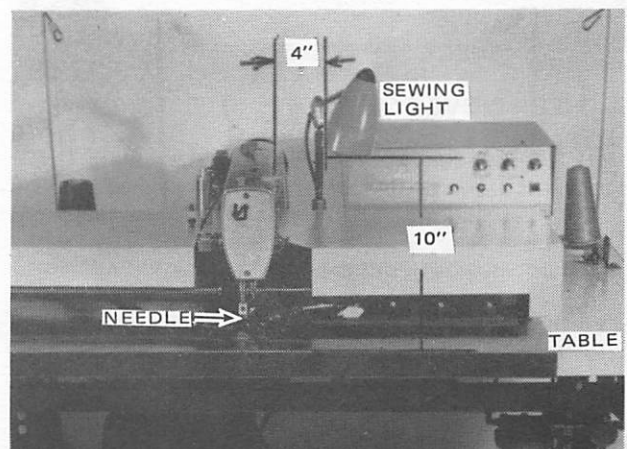

ADJUST SEWING LIGHT

- (5) Thread the machine according to the threading diagrams. This machine uses needle types 135-RMN-116, 135 x 9 size 16, regular round point for woven material; 135-RMN-216, 135 x 9 SUK size 16, medium ball point for either knit or woven material; and magnetic bobbin case No. 63913 B.

F. CHECK ROTATION OF SEWING HEAD

- (1) Be sure air is not connected to unit.
- (2) Remove synchronizer plug from motor control panel.
- (3) Connect power supply to main switch box.
- (4) Turn main switch ON.
- (5) Manually depress clutch arm on main motor.
- (6) Proper rotation is clockwise looking from operator position.
- (7) If rotation is wrong, simply reverse any two of three incoming power supply lines to the unit main switch box.

G. INSTALLATION

CAUTION

The unit is properly grounded. Your outlet must be grounded to ensure adequate protection for the operator and the equipment.

- (1) Add oil to the air lubricator per instructions in maintenance, Section V. Connect the air supply line to the unit and adjust the regulator to 45 psi.

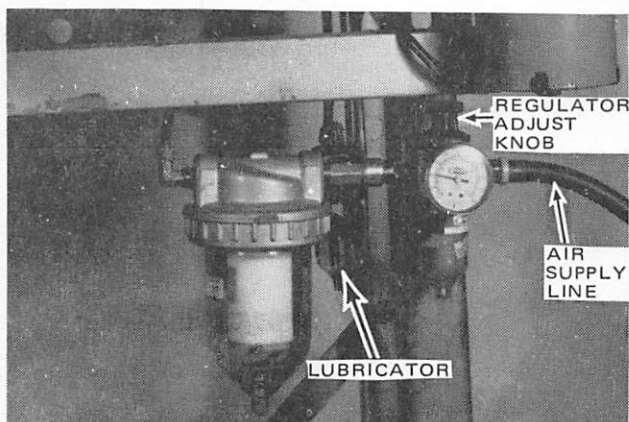

OIL LUBRICATOR AND CONNECT AIR SUPPLY

- (2) Turn main power switch OFF and rotate hand-wheel (clockwise from the operator's position) until the needle thread takeup lever is 1/8 inch below top of stroke.
- (3) Be sure all plugs are plugged into the motor control panel. Turn both main and control box switches ON.

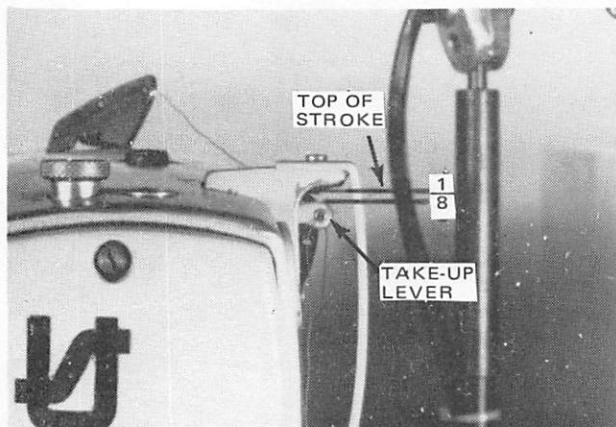

POSITION TAKE-UP LEVER

NOTE

Be sure the supply line has been purged of any contaminants and/or moisture before attaching to the unit. Also, observe the air filter bowl during the first half hour of operation to be sure no appreciable accumulation occurs. Accumulated moisture can be drained by depressing the plunger in the bottom of the air filter bowl. If the accumulation in the filter bowl is not removed, excessive oil and water will build up in control system, eventually causing malfunction. A considerable amount of time will then be required to drain and clean the system before resuming normal operation.

- (4) Locate the sewing light approximately 9 to 10 inches above the table and about 4 inches to right of needle. Turn light to illuminate the needle area.

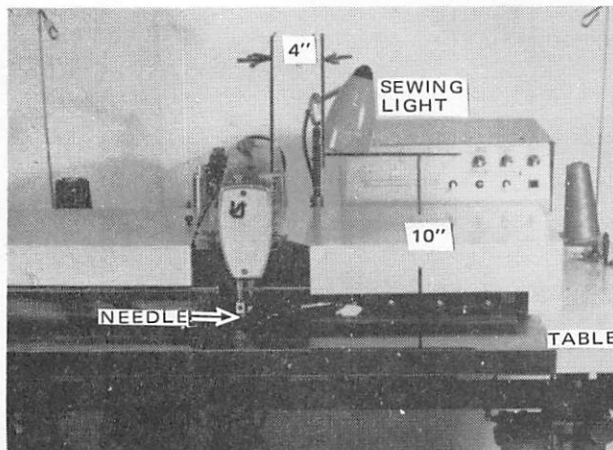

ADJUST SEWING LIGHT

- (5) Thread the machine according to the threading diagrams. This machine uses needle types 135-RMN-116, 135 x 9 size 16, regular round point for woven material; 135-RMN-216, 135 x 9 SUK size 16, medium ball point for either knit or woven material; and magnetic bobbin case No. 63913 B.

CAUTION

Do not use any other needle except those listed without consulting your Union Special representative.

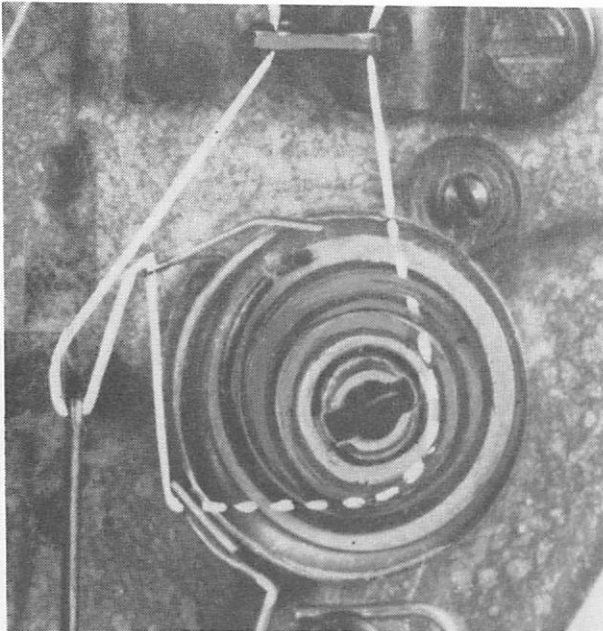

MACHINE THREADING DIAGRAM



MACHINE THREADING DIAGRAM

(6) Check the settings of the photocells and control systems.

NOTE

Before operating unit to check for proper stitch length and stop position, read Section II, Operation. Stitch length adjustment is found in Section IV. Stop position control adjustments are found in Section IV.

H. OPERATION

(1) When the unit is ready for operation, the clamp will be at the extreme right end of its stroke in raised position. The vision flap is open for better visibility for positioning the work.

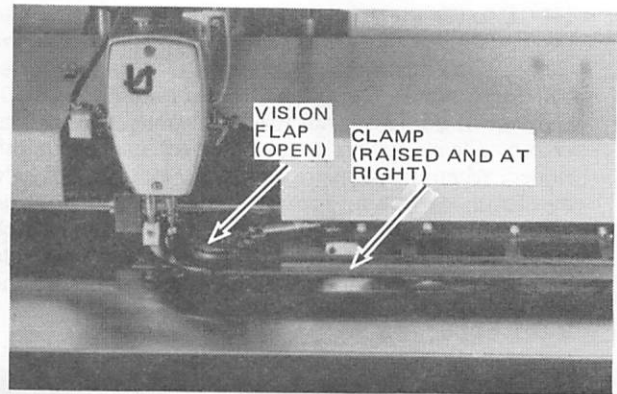

MACHINE READY FOR OPERATION

(2) Place the pre-pressed left fly under the clamp with zipper facing down. Be sure that the edge of the material is just covering the needle hole in the throat plate. The waistband end of the fly should be against the edge guide, which is set to margin requirements.

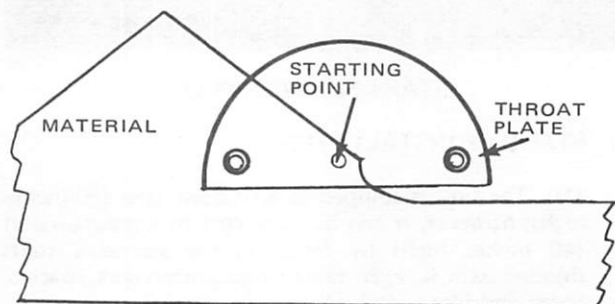

POSITIONING MATERIAL

(3) Hold the bottom of fly with left hand to the left of the clamp, and the top of the fly with the middle finger of the right hand in the clearance cut in the clamp. With the thumb holding the material outside the front edge of the clamp, stretch the material slightly by holding the left hand stationary and moving the right hand to the right. Keep fingers clear of underside of clamp.

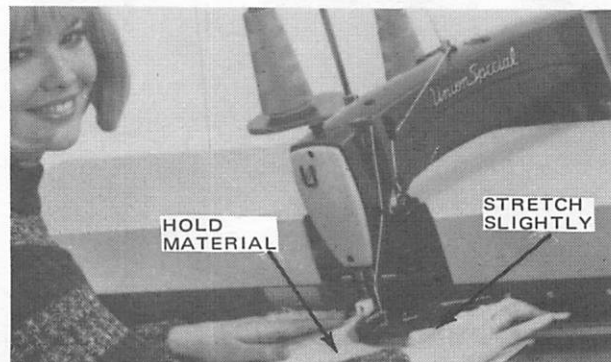

CLAMPING MATERIAL

(4) Depress the foot switch to the first position to begin. This will blow the needle thread from under the clamp, close the vision flap, lower clamp and presser bar clamp block. Remove hands and check position of garment. If garment is not loaded properly, release foot switch. Clamp will raise and garment can be repositioned. When the garment is properly inserted and held by clamp, depressing foot switch to second position will start the automated sewing cycle. Foot switch may now be released. The machine will sew, complete its positioning and trimming cycle, and return to the starting position.

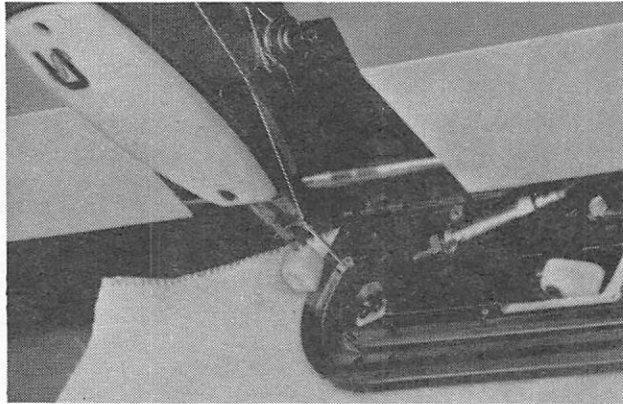

START SEWING CYCLE

I. STAND-UP INSTALLATION

(1) The unit is shipped as a sit down unit (30 inches high); however, it can be converted to a stand up unit (40 inches high) by installing the accessory parts shipped with it: eight table leg extension bars, spacers, bolts, and foot switch conversion parts.

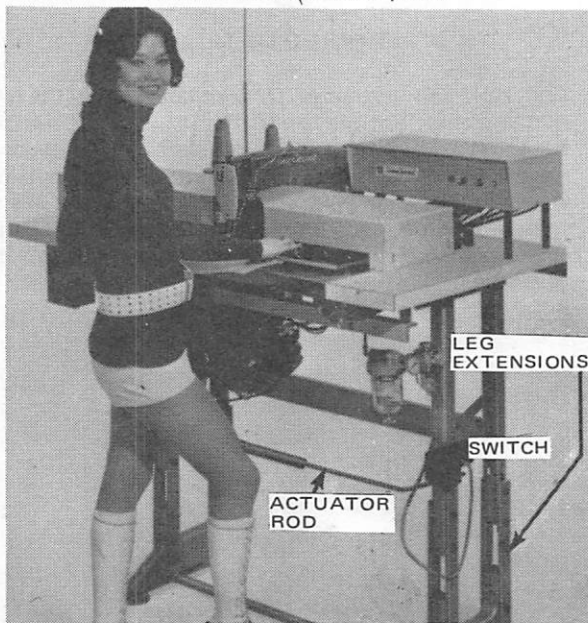

(2) Raise the unit approximately 12 inches off the floor and firmly support it. Be sure not to pinch any wires or air tubes. MAKE CERTAIN that the unit will not fall.

(3) Remove the lower portion of the table legs by removing the four bolts and treadle rod.

(4) Assemble the lower portion separately. Before assembling the unit, be sure that the spacers are installed properly and that the extra long extension leg is on the outside of the right front leg.

(5) Attach the lower assembly to the legs of the unit. Tighten securely and carefully lower the unit to the floor.

LEG EXTENSIONS

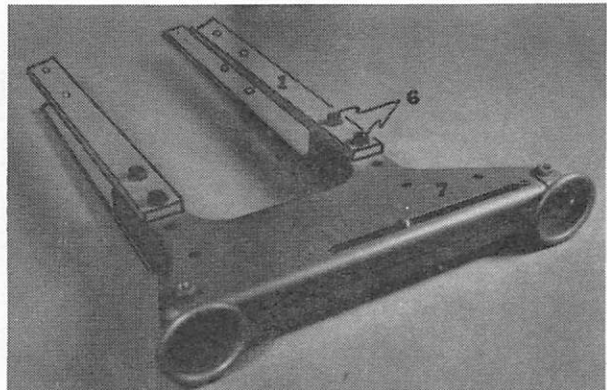
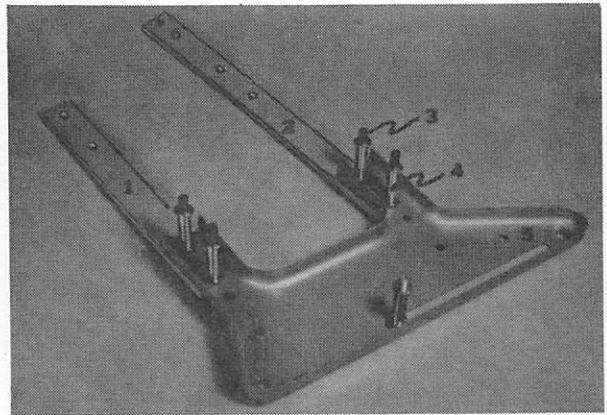

LEG EXTENSION PARTS LIST

REF NO	PART NO	DESCRIPTION	AMT REQ
1	RM 3454	Leg Extension	7
2	RM 3449	Outer Right Front Leg Extension	1
3	RM 2827-9	3/16-16 x 3" H.H.S.	16
4	51-214 BLK	Spacers	10
5	21371 WF	Right-hand Side Plate	2
6	652 L-24	Washer	16
7	RM 3211-3	3/8-16 Hex Nut	8
	21371 WE	Left-hand Side Plate	2

(6) Assemble the switch conversion parts.

SWITCH ACTUATOR

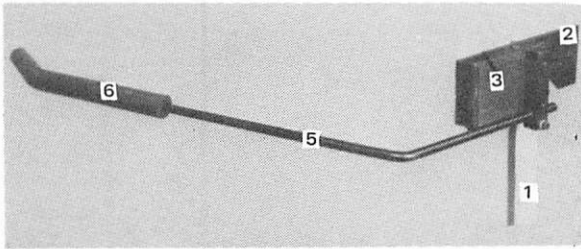

SWITCH ACTUATOR PARTS LIST

REF NO	PART NO	DESCRIPTION	AMT REQ
1	RM 3449	Switch Plate Leg Extension	1
2	RM 3450	Start Switch Plate	1
	RM 3162-6	1/4-20 x 1/2 H.H.S.	2
3	RM 3351	Start Switch Assembly	1
4	22652 A-6	8-32 x 3/8 S.H.S.	3
	RM 3453	Rod Support	1
	RM 3306-2	10-32 x 5/8 S.H.S.	2
5	RM 3451	Actuator Rod	1
	RM 3306-2	10-32 x 5/8 S.H.S.	1
6	RM 3452	Rod Sleeve	1

(6) Assemble the switch conversion parts.

SWITCH ACTUATOR

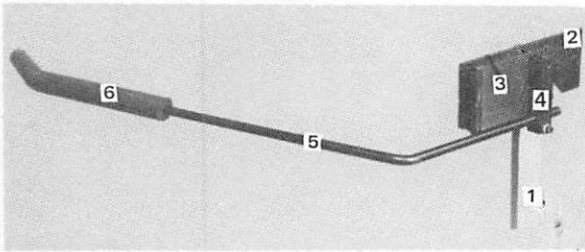

SWITCH ACTUATOR PARTS LIST

REF NO	PART NO	DESCRIPTION	AMT REQ
1	RM 3449	Switch Plate Leg Extension	1
2	RM 3450	Start Switch Plate	1
	RM 3162-6	1/4-20 x 1/2 H.H.S.	2
3	RM 3351	Start Switch Assembly	1
	22652 A-6	8-32 x 3/8 S.H.S.	3
4	RM 3453	Rod Support	1
	RM 3306-2	10-32 x 5/8 S.H.S.	2
5	RM 3451	Actuator Rod	1
	RM 3306-2	10-32 x 5/8 S.H.S.	1
6	RM 3452	Rod Sleeve	1

SECTION III OPERATOR INSTRUCTIONS

A. OPERATING HINTS

- (1) Be sure a slight amount of stretch is applied to fly and held until clamp contacts it.
- (2) Do not pull on garment once clamp is down.
- (3) Do not assist the material in any way until after cycle is completed.
- (4) If machine skips stitches or breaks thread, check needle; check for proper threading.
- (5) If bobbin thread does not cut at end of cycle, check threading of bobbin case.

B. MACHINE CARE

- (1) Every day: replace needle first thing before operating; check oil sight gauge on sewing head; check oil level in air lubricator mounted on right front table leg. If either oil level is low, notify the mechanic at once.
- (2) Mid-day and end of day: with bobbin case removed, blow lint from hook area with air hose (see Section IV).

C. SEQUENCE OF OPERATION

(1) Refer to timing chart. When the unit is in the rest position with both main and control switches ON, the following conditions are in effect.

- a. The electric clutch is energized with approximately 10 volts dc.
- b. Solenoid A is de-energized, shutting off air to the thread wiper system.
- c. Solenoid B is de-energized, with electro-drive clutch cylinder retracted and the unit not sewing.
- d. Solenoid C is de-energized, shutting off air to backtack lever cylinder controlling the reverse feed cycle.
- e. Solenoid D is de-energized. This normally open solenoid supplies air to the clamp lift cylinder (clamp is up), and the presser foot cylinder (presser foot is up).
- f. Solenoid E is de-energized, shutting off air to the vision flap cylinder, which is retracted to keep the vision flap open.

(2) The operator loads the material and depresses the foot switch to engage and close the first position switch FS1. The following occurs.

- a. Air wiper blows as solenoid A is energized.
- b. Clamp and presser bar drop as solenoid D is energized. When the lifter lever moves, the normally closed clamp interlock switch opens, preparing machine to operate.

c. Vision flap closes as solenoid E is energized.

d. The voltage to the electric clutch is increased to 90 volts dc, preparing clamp to feed.

(3) The foot switch is then depressed further, engaging and closing the second position switch FS2. The following occurs.

a. A time delay control delays solenoid B being energized, preventing machine from going into high speed mode.

b. The machine starts sewing in the low speed mode through the main motor circuit.

c. The control circuit locks unit into automatic operation so that the voltages to solenoids E and D are held independent of the foot switch.

d. The foot switch can be released at this point. Solenoid A de-energizes when the foot switch is completely released, shutting off the air wiper.

e. After the time delay is timed out, solenoid B is energized, supplying air to the electro-drive clutch cylinder which engages the clutch. The machine will then run at high speed.

(4) When the clamp moves the pants panel, exposing the photocell to the machine light at the end of the waistband, a time delay occurs before stopping. The machine will continue to run at high speed until this stop position time delay is completed. At the end of this delay, the following occurs.

a. Solenoid B is de-energized, causing the quick clutch to disengage and bring machine from high speed operation to low speed.

b. Needle positioning and trimming cycles occur.

c. After a pre-set time delay to ensure completion of position and trimming cycles, solenoid D is de-energized, allowing clamp to raise.

d. Solenoid E is de-energized, opening up vision flap.

e. Electric clutch voltage decreases from 90 to 10 volts dc, preparing for clamp return.

f. The clamp return delay begins, providing time for the clamp to raise and the presser bar to retract before the clamp starts its return cycle.

g. When the clamp raises, the clamp interlock switch on the sewing head is engaged by the lifter lever and closes, preparing the control circuit for the next sewing cycle.

h. After the clamp return delay times out, the clamp return motor is activated, returning the clamp to the start position.

i. When the clamp returns to the start position, a stud on the left-hand drive pulley engages the clamp return limit switch, which shuts off power to the clamp return motor.

(5) The unit is now in the rest position, ready for the loading of the next panel.

(6) The above sequence of operation is given with the backtack switch in the NO position. If backtack is desired at the waistband end of the garment, place the backtack switch at the YES position. The sequence of operations is identical to the point at which solenoid B is de-energized, paragraph 4a. When high speed sewing cycle ends, main motor decelerates to slow speed. The sequence will be as follows.

a. The backtack timer is started.

b. Backtack solenoid C is energized, supplying air to the backtack cylinder. This causes the reversing arm on the transmission drive to move, driving the clamp in the reverse direction.

c. The backtack timer times out, causing backtack solenoid D to de-energize.

d. Air supplied to the backtack cylinder is shut off, causing the reversing arm on the transmission drive to return to the forward position.

(7) The rest of the operation sequence is described in the non-backtack sequence, beginning with paragraph 4b.

TIMING CHART

NOTE

Machine is in rest position with both main and control switches on.

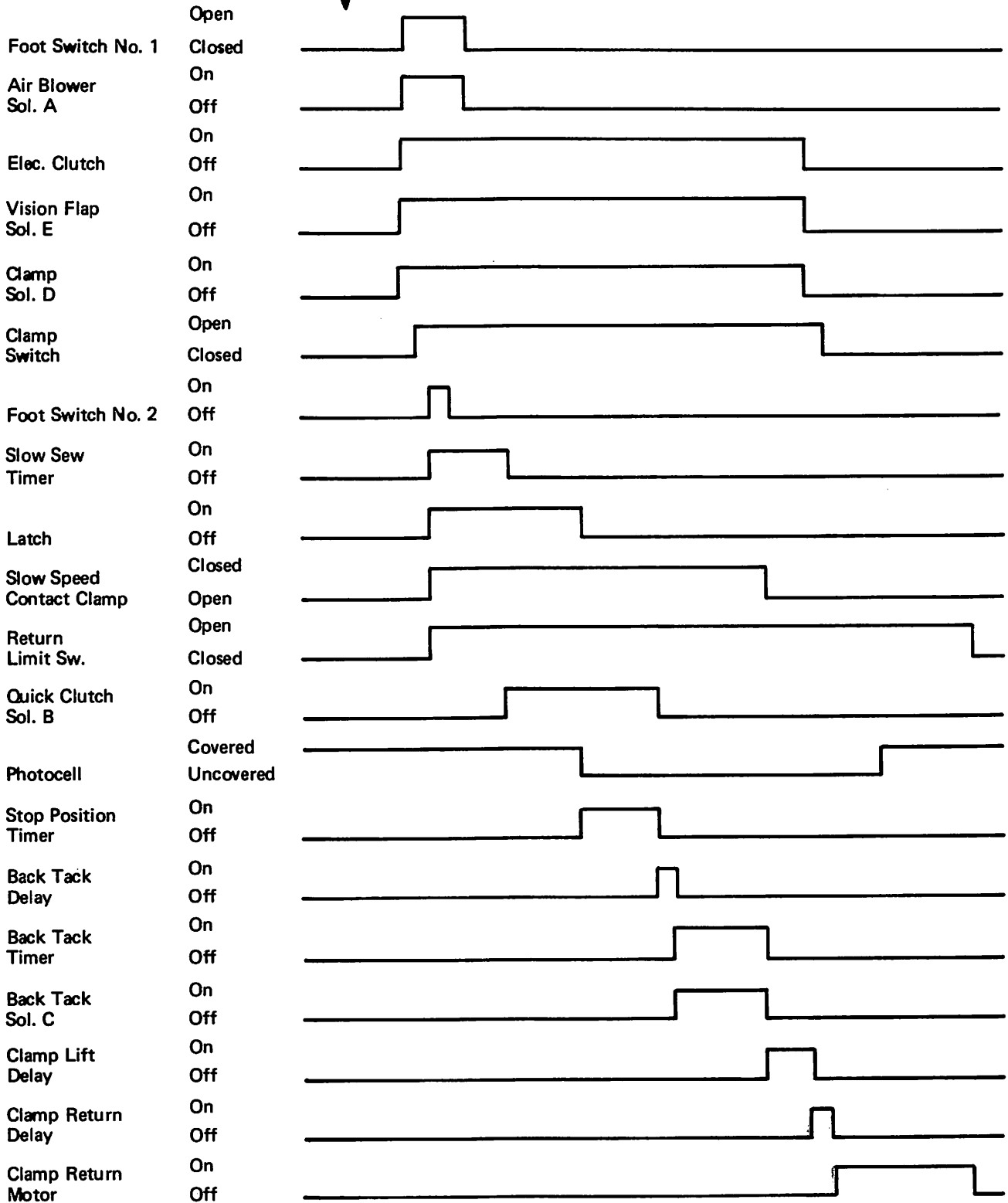

SECTION IV
DESCRIPTION AND ADJUSTMENT OF ELECTRICAL CONTROLS

A. SWITCHES

(1) 2800 E-2 is available in the following voltage ranges:

- 220 V ± 15%, 3 phase, 6 amps, 60 Hz
- 220 V ± 10%, 3 phase, 7 amps, 50 Hz
- 380 V ± 10%, 3 phase, 5 amps, 50 Hz
- 440 V ± 10%, 3 phase, 4 amps, 50 Hz

(2) Main power switch, under left-hand side of the table, controls the power to the electro-drive, needle positioner, trim cycle, machine light, and the control box.

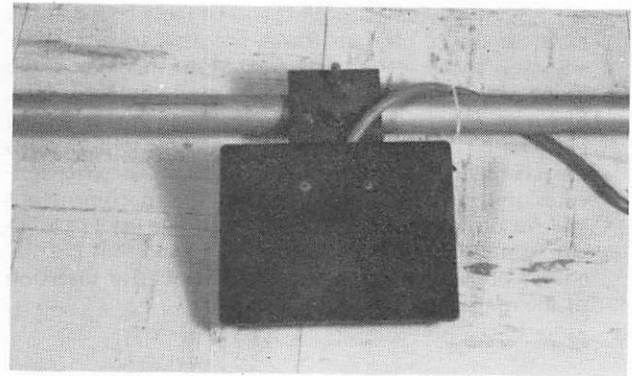

STARTING SWITCH

(5) Threading switch (clamp lift switch), on control box, is used to lower the clamp so that the needle is better exposed for threading. After threading, the switch should be moved to the operating position so that the clamp will lift, ready for the insertion of the next garment piece. If the switch is left in the threading position, the clamp remains down and the return motor is inactivated.

(6) Backtack selector switch, on control panel, just left of the control power switch. When the backtack selector switch is in the NO position, the unit will topstitch a left fly without backtacking at the waistband end. If the backtack selector switch is in the YES position, the unit will topstitch a fly with a backtack at the end of seam.

(7) Start interlock clamp switch, on side of machine, is actuated by the presser lift cylinder. It is used as an interlock to ensure that the machine will not sew when the clamp is up and that the clamp will be down before the machine starts automatic mode.

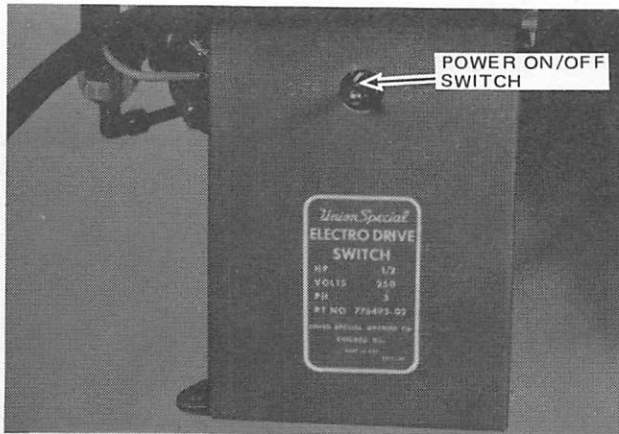

MAIN POWER SWITCH BOX

(3) Control power switch, on face of control box, controls all functions of the unit except the electro-drive, needle positioning, trim cycle, and sewing machine light.

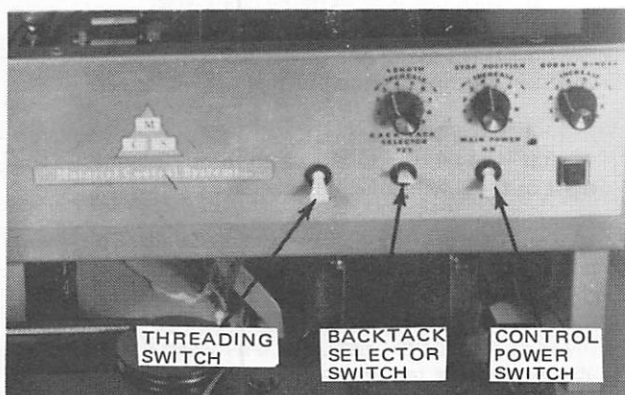

FRONT OF CONTROL BOX

(4) Starting switch, on treadle rod, is a two position foot switch. Depressing the switch to the first switch position causes the clamp to lower on the material. Further movement causes the machine to lock into its automatic cycle mode. The switch can be adjusted both left and right by loosening the pipe clamp on the switch bracket and sliding the switch assembly to the position required. The forward or backward adjustment is made by moving the entire treadle rod in desired direction (the same way as on standard tabling).

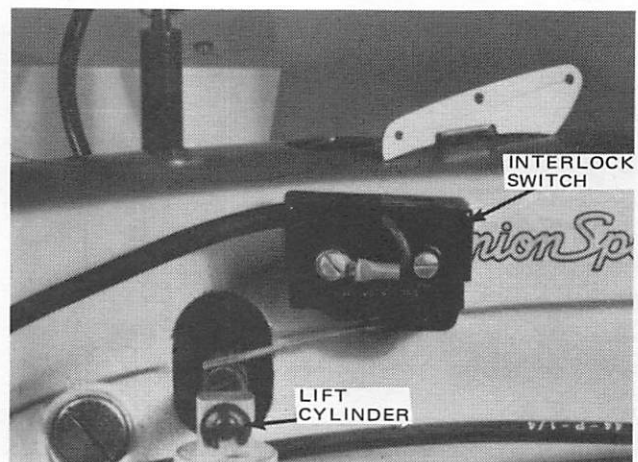

START INTERLOCK CLAMP SWITCH

(8) Safety switches, on left end of table board at the extreme end of carriage travel, are used to automatically stop and reset the sequence of the machine in the event of a photocell or automatic stop control failure. They are actuated by the carriage when it reaches the extreme left end of its travel. The lower switch keeps the clamp from lifting and, at the same time, de-activates the clutch cylinder so that the machine stops and no damage occurs to the clamp. The upper switch automatically resets the control circuit so that the machine will return to the proper sequence for insertion of the material.

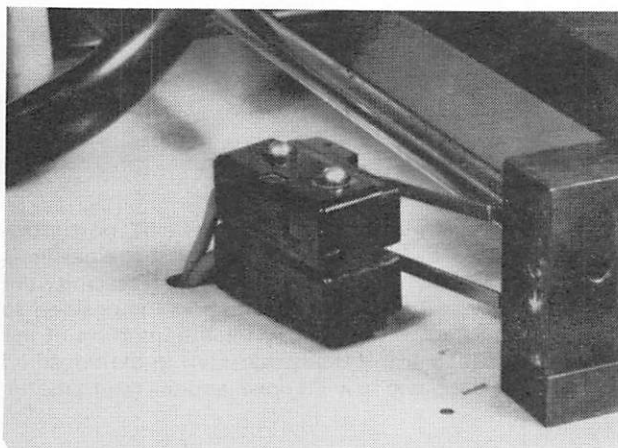

SAFETY SWITCHES

B. CARRIAGE RETURN CONTROL

The speed of the carriage during the return stroke is controlled by the gear motor on the left-hand side of the unit. The speed is not adjustable, and the only adjustment which may have to be made is in the operation of the shut-off switch, which is activated by the bumper on the underside of the drive pulley. This switch shuts off the power going to the return motor so that it does not stop with the power on. If the motor, when it reaches the extreme right end of the travel, begins to oscillate, the actuating lever of the switch has to be rebent to engage the bumper sooner.

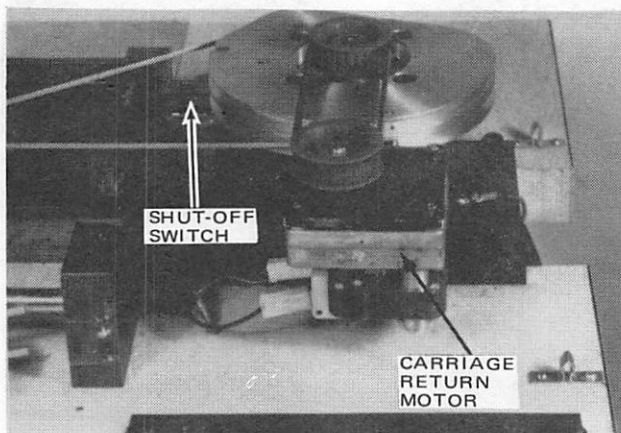

CARRIAGE RETURN CONTROL

C. PHOTOCELL

(1) This unit, once it is manually started, sews and stops automatically by an electronic circuit using a photocell sensor. The cell is in the table top under the fabric clamp approximately 4-1/2 inches to the right of the needle. The photocell senses the waistband edge of the garment and initiates the stopping sequence or begins the backtacking sequence.

(2) Photocell sensitivity controls inside the control box adjust the sensitivity or firing point of the photocell to properly sense the full range of fabrics.

(3) To set sensitivity:

a. Turn pot A on the PC board to extreme clockwise.

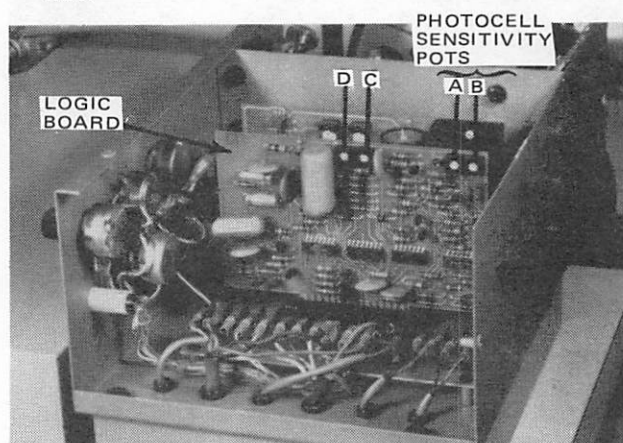

INSIDE CONTROL BOX

b. Turn pot B to extreme clockwise.

c. Turn the main power switch ON. Keep the control box power switch turned off.

d. Put a piece of material underneath the clamp so that it extends approximately 8 to 10 inches to the right of the sewing machine needle.

e. Remove the air from the machines. The clamp and the presser bar will go down.

f. Adjust the sewing machine light so that the lower portion of the deflector is between 8 to 10 inches above the table top and is illuminating the area around the needle.

g. Turn the control power ON. Machine will operate at low speed. Notice that the light emitting diode on the PC board is lit.

h. Let the machine run until the photocell is fully illuminated.

i. Slowly turn pot B counterclockwise until the light emitting diode turns off.

j. The machine will stop, position and trim. Turn off the control power switch as soon as possible.

(8) Safety switches, on left end of table board at the extreme end of carriage travel, are used to automatically stop and reset the sequence of the machine in the event of a photocell or automatic stop control failure. They are actuated by the carriage when it reaches the extreme left end of its travel. The lower switch keeps the clamp from lifting and, at the same time, de-activates the clutch cylinder so that the machine stops and no damage occurs to the clamp. The upper switch automatically resets the control circuit so that the machine will return to the proper sequence for insertion of the material.

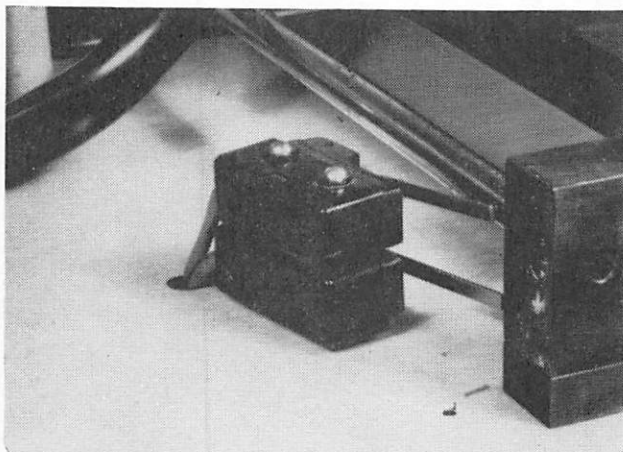

SAFETY SWITCHES

B. CARRIAGE RETURN CONTROL

The speed of the carriage during the return stroke is controlled by the gear motor on the left-hand side of the unit. The speed is not adjustable, and the only adjustment which may have to be made is in the operation of the shut-off switch, which is activated by the bumper on the underside of the drive pulley. This switch shuts off the power going to the return motor so that it does not stop with the power on. If the motor, when it reaches the extreme right end of the travel, begins to oscillate, the actuating lever of the switch has to be re-bent to engage the bumper sooner.

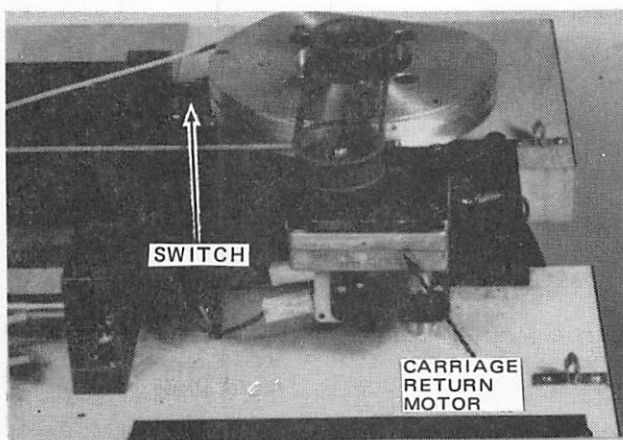

CARRIAGE RETURN CONTROL

C. PHOTOCELL

(1) This unit, once it is manually started, sews and stops automatically by an electronic circuit using a photocell sensor. The cell is in the table top under the fabric clamp approximately 4-1/2 inches to the right of the needle. The photocell senses the waistband edge of the garment and initiates the stopping sequence or begins the backtacking sequence.

(2) Photocell sensitivity controls inside the control box adjust the sensitivity or firing point of the photocell to properly sense the full range of fabrics.

(3) To set sensitivity:

a. Turn pot A on the PC board to extreme clockwise.

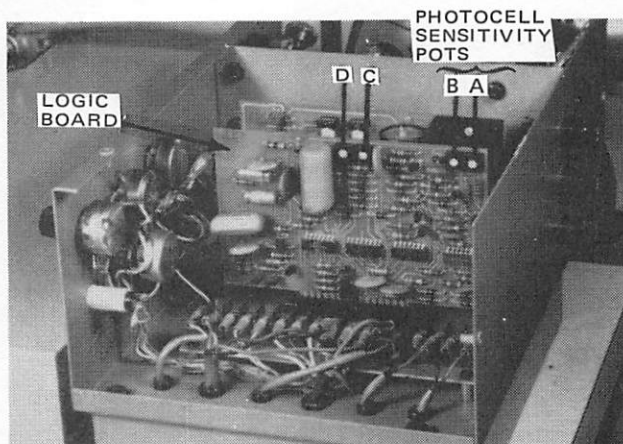

INSIDE CONTROL BOX

b. Turn pot B to extreme clockwise.

c. Turn the main power switch ON. Keep the control box power switch turned off.

d. Put a piece of material underneath the clamp so that it extends approximately 8 to 10 inches to the right of the sewing machine needle.

e. Remove the air from the machines. The clamp and the presser bar will go down.

f. Adjust the sewing machine light so that the lower portion of the deflector is between 8 to 10 inches above the table top and is illuminating the area around the needle.

g. Turn the control power ON. Machine will operate at low speed. Notice that the light emitting diode on the PC board is lit.

h. Let the machine run until the photocell is fully illuminated.

i. Slowly turn pot A counterclockwise until the light emitting diode turns off.

j. The machine will stop, position and trim. Turn off the control power switch as soon as possible.

k. Attach the air to the system and turn on the control power switch. The clamp will return to the starting position.

l. Operate the machine in a normal manner, using a single layer of thin pants material. Machine should function properly; and if not, turn pot B counterclockwise by 15° increments, repeating steps (b) through (k). After the machine goes through the proper sequencing, the electric eye circuit can be considered properly calibrated, and the machine put into operation.

D. STOP POSITION CONTROL

(1) The control is part of the delay function in the photo-electric sensing system and consists of two potentiometers on the face of the control box. They are used to adjust the position of the final stop-trim cycle or the beginning of the backtack cycle, depending upon the position of the backtack selection switch. The stop position control adjustment determines where the sewing machine will stop in relation to the waistband edge.

(2) The fine adjustment pot is labeled STOP POSITION. The coarse adjustment pot screw is accessible through the small hole just to the lower right of the stop position control knob.

(3) Adjustment to the coarse pot should be made with the fine pot set at 4½ on the dial face. Place an 8 to 10 inch double ply square of material under the fabric clamp and operate machine. Machine should stop at edge of fabric. If machine stops before edge of material, rotate coarse pot adjusting screw clockwise until machine stops on edge. If machine runs beyond edge, rotate coarse pot counterclockwise until machine stops at edge. All further adjustments should be made with the stop position control knob.

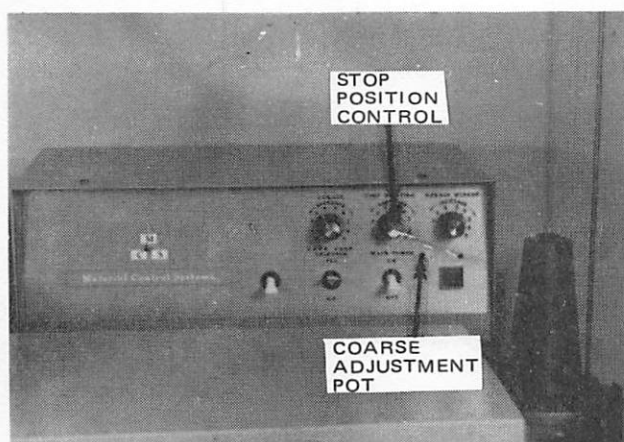

FRONT OF CONTROL BOX

E. SLOW SPEED START ADJUSTMENT

The machine will start in low speed, and the number of stitches the machine sews at this speed is controlled by a pot in the control box. Turning pot C clockwise increases the number of stitches produced in the low speed mode. Counterclockwise decreases the number of stitches. The average number of stitches sewed at this speed should be 2 to 4. Any more than 4 only increases the cycle time of the unit.

F. CLAMP RAISE DELAY

Delay in raising of clamp allows for the finishing of the trimming operation. This is controlled by pot D mounted on the PC board in the control box. By turning this pot clockwise, the delay time between the trimming operation and the clamp raising is increased.

NOTE

The clamp should not raise until the trimming operation has been completed.

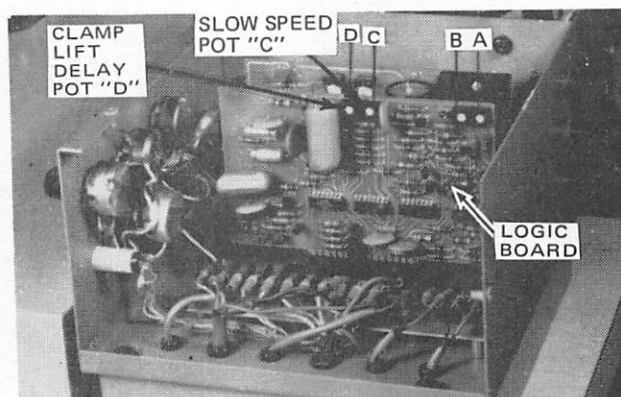

INSIDE CONTROL BOX

G. BACKTACK LENGTH CONTROL

This control on the face of the control box just above the backtack selector switch controls the number of stitches in the backtack sewing operation. Turning the knob counterclockwise will reduce the number of stitches in the backtack sequence; clockwise will increase the number of stitches.

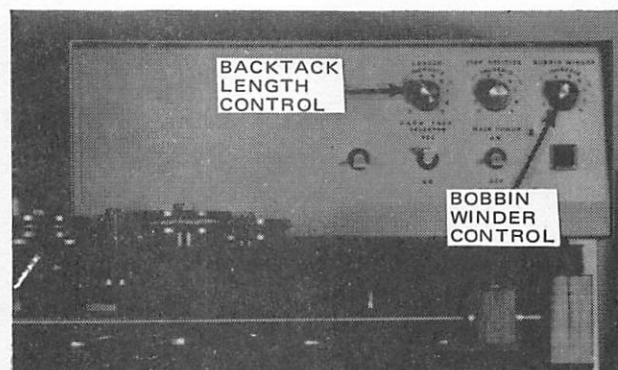

FRONT OF CONTROL BOX

k. Attach the air to the system and turn on the control power switch. The clamp will return to the starting position.

l. Operate the machine in a normal manner, using a single layer of thin pants material. Machine should function properly; and if not, turn pot A counterclockwise by 15° increments, repeating steps (b) through (k). After the machine goes through the proper sequencing, the electric eye circuit can be considered properly calibrated, and the machine put into operation.

D. STOP POSITION CONTROL

(1) The control is part of the delay function in the photo-electric sensing system and consists of two potentiometers on the face of the control box. They are used to adjust the position of the final stop-trim cycle or the beginning of the backtack cycle, depending upon the position of the backtack selection switch. The stop position control adjustment determines where the sewing machine will stop in relation to the waistband edge.

(2) The fine adjustment pot is labeled STOP POSITION. The coarse adjustment pot screw is accessible through the small hole just to the lower right of the stop position control knob.

(3) Adjustment to the coarse pot should be made with the fine pot set at 4½ on the dial face. Place an 8 to 10 inch double ply square of material under the fabric clamp and operate machine. Machine should stop at edge of fabric. If machine stops before edge of material, rotate coarse pot adjusting screw clockwise until machine stops on edge. If machine runs beyond edge, rotate coarse pot counterclockwise until machine stops at edge. All further adjustments should be made with the stop position control knob.

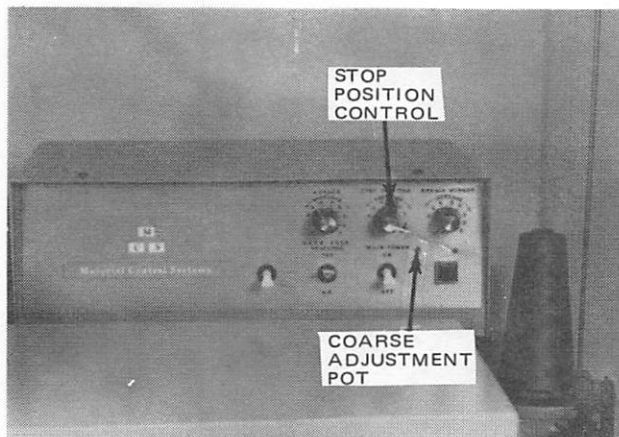

FRONT OF CONTROL BOX

E. SLOW SPEED START ADJUSTMENT

The machine will start in low speed, and the number of stitches the machine sews at this speed is controlled by a pot in the control box. Turning pot C clockwise increases the number of stitches produced in the low speed mode. Counterclockwise decreases the number of stitches. The average number of stitches sewed at this speed should be 2 to 4. Any more than 4 only increases the cycle time of the unit.

F. CLAMP RAISE DELAY

Delay in raising of clamp allows for the finishing of the trimming operation. This is controlled by pot D mounted on the PC board in the control box. By turning this pot clockwise, the delay time between the trimming operation and the clamp raising is increased.

NOTE

The clamp should not raise until the trimming operation has been completed.

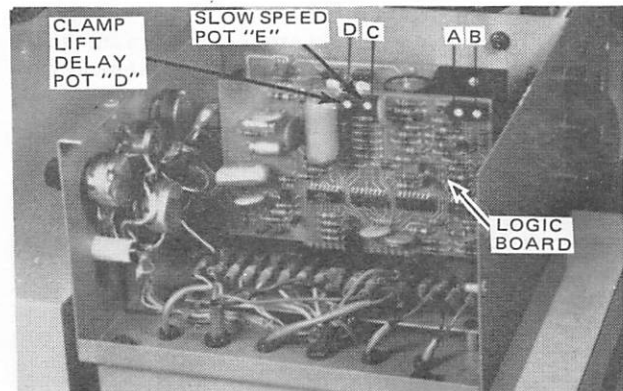

INSIDE CONTROL BOX

G. BACKTACK LENGTH CONTROL

This control on the face of the control box just above the backtack selector switch controls the number of stitches in the backtack sewing operation. Turning the knob counterclockwise will reduce the number of stitches in the backtack sequence; clockwise will increase the number of stitches.

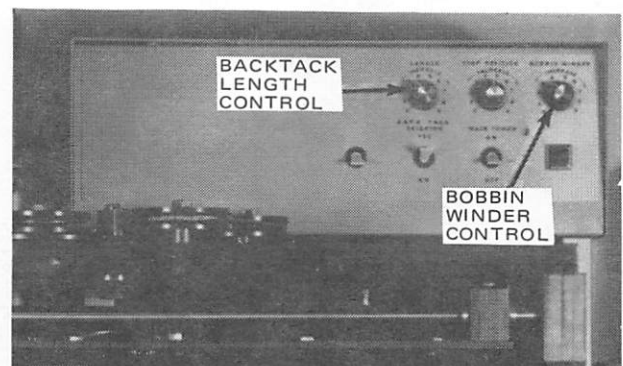

FRONT OF CONTROL BOX

H. BOBBIN WINDER CONTROL

(1) The bobbin winder is on the right side of the unit. It is controlled by an electronic timing circuit. The potentiometer on the control box face adjusts the fullness of the bobbin by controlling the time of bobbin filling. If turned counterclockwise, less thread will be put on the bobbin, while clockwise puts more thread on the bobbin.

(2) The button under the table near the bobbin winder starts the bobbin winding cycle. To operate bobbin winder, place bobbin on the bobbin winding stud and wind a few turns of thread counterclockwise. Then momentarily depress the bobbin winder start button, and the bobbin winder will start the winding cycle. After the pre-selected time, the bobbin winder will stop and the bobbin will be full. If not, the adjustment can be made on the control knob.

I. PNEUMATIC CONTROLS

(1) The unit requires a minimum air supply of 65-75 psi and consumes up to 2-½ cubic feet of air per minute.

(2) The main regulator controls the air pressure to the entire system. It is mounted on the right-hand table leg and should be set at 45–55 psi.

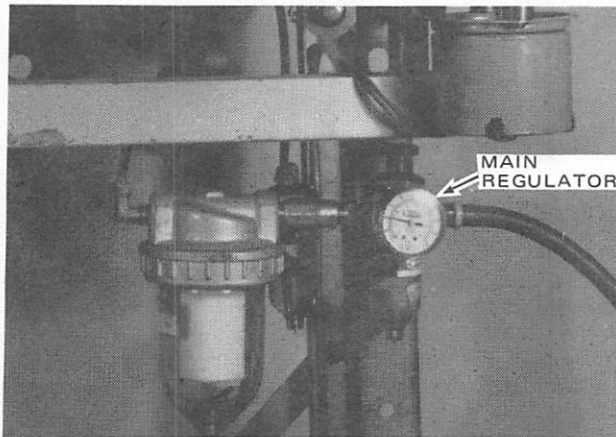

AIR SUPPLY SYSTEM

(3) The thread wiper blower is an air tube in the clamp which blows the needle thread from under the clamp. This air supply is controlled by a flow control valve and should be adjusted to the lowest possible value that will consistently blow the needle thread from under the clamp.

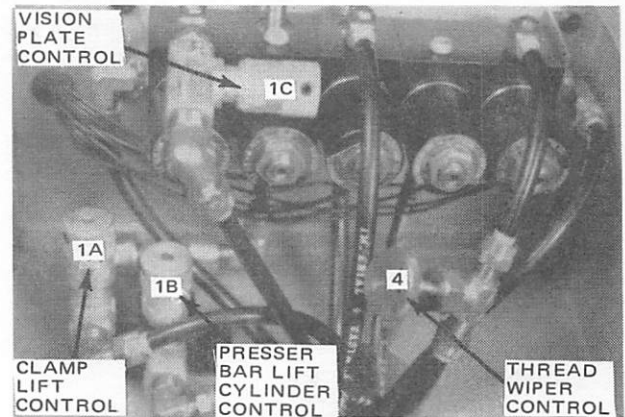

FLOW CONTROL VALVES

(4) The clamp lift control should be set so the clamp lifts without banging, but fast enough to avoid any loading or unloading delays.

(5) The presser bar lift cylinder control should be adjusted so the clamp is down on the material before the pressure clamp block contacts the clamp.

(6) The vision plate control should be set to delay the opening of the vision plate until the clamp is off the material.

J. UNIT MECHANICAL SYSTEMS

(1) Adjustment of stitch length is made with the control lever on the transmission drive under the left side of the table board. Turn the red knob counterclockwise to unlock the adjustment arm and swing the arm to the left to decrease the stitch length. When stitch length is set, tighten the red knob on the adjustment arm to lock in position. After the stitch length has been changed, it will be necessary to readjust the time delay control for the proper stop position. Refer to Section IVD.

NOTE

Do not exceed the stitch range of 10 to 18 spi.

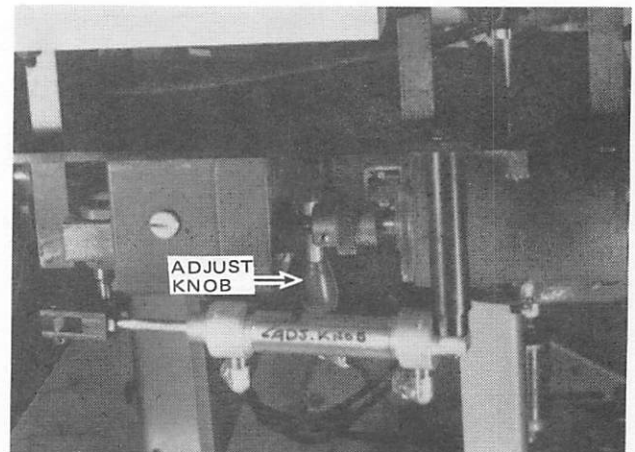

DRIVE SYSTEM

(2) Starting position, due to variations in pattern and width of fly margin, will vary. Adjust by turning the knob on the left-hand side of the unit. Turning the knob counterclockwise moves the starting position closer to the straight line of stitching. Turning the knob clockwise moves the starting position further from the straight line of stitching.

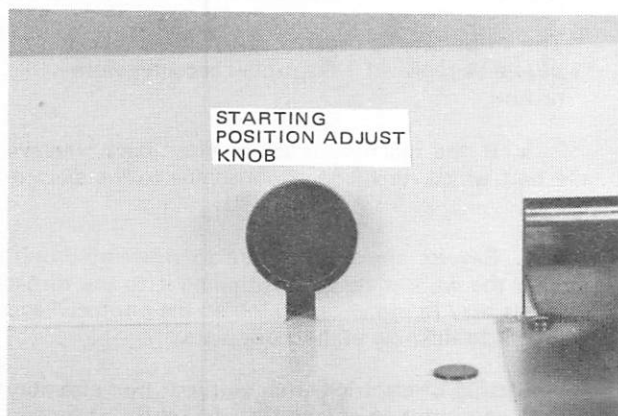

LEFT END OF MACHINE

(3) The edge guide on the clamp is used to assist in locating the work. Adjust by loosening the screw holding the guide and moving it in or out to suit sewing margin requirements.

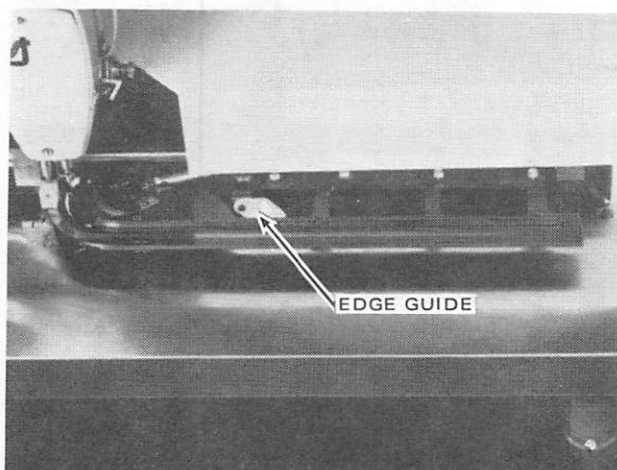

CLAMP AREA

(4) Adjusting relative position of clamp needle slot to the needle is an important setting. Any misalignment can cause machine damage. The adjustment should be made with the main switch turned off and the air supply disconnected.

- a. Remove the two sheet metal covers covering the clamp mechanism.
- b. Raise the clamp slightly and move it through its full travel, noting the relationship between the needle hole in the throat plate and the needle slot in the clamp.

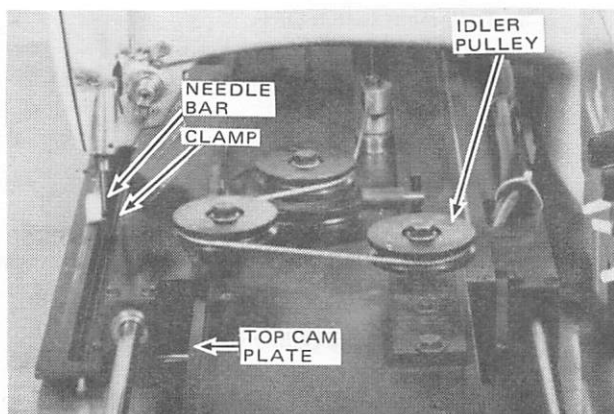

ADJUSTING CLAMP POSITION

c. The needle hole should remain in the center of the clamp needle slot throughout the length of travel.

To adjust for misalignment:

- a. Loosen the idler pulley to obtain slack in the cable.
- b. Loosen the four allen head bolts (two on each end) holding the top cam plate in position.
- c. Tap the cam plate to change the needle hole to needle slot relationship. When the cam is to the left, tap the left end of the top plate to reposition.
- d. When the clamp is properly located and the allen head bolts are retightened, take up the slack in the cable by adjusting the idler pulley.

CAUTION

The tension applied to the cable is critical. Too much tension can cause a bind in the return action of the clamp. Too little tension can allow too much slack in the line, causing the machine to sew in one place at the start and on the backtack, resulting in needle thread breakage.

(5) Removing the top mechanism for major adjustment or repairs.

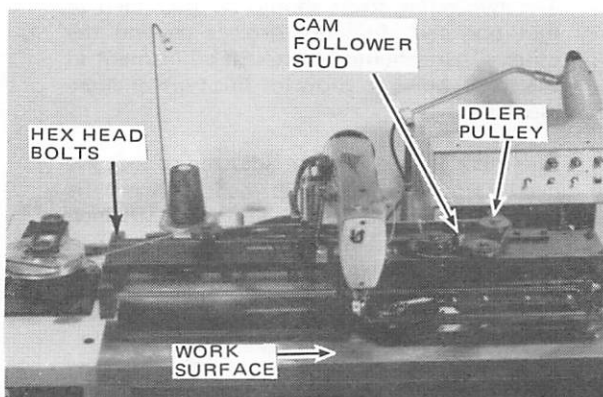

REMOVING TOP MECHANISM

- a. Turn main switch OFF.
- b. Disconnect main air supply.
- c. Remove 2 top covers.
- d. Remove needle from sewing head.
- e. Disconnect air lines to clamp lift cylinder, blower tube and vision flap. The disconnect fittings are under the rear of the table board.
- f. Loosen the idler pulley.
- g. Remove cable pivot from cam follower stud.
- h. Remove 4 hex head bolts, 2 from each end.
- i. Remove 2 pan head screws holding the work surface in place and slide out sheet. Avoid bending the spring clip on the underside of the stainless steel plate, which slides under the throat plate to hold it in place. It may be necessary to lift the back end of the plate over the throat plate with a screwdriver, or reach under the table board and push up under the front of the plate enough to raise it over the throat plate for removal.
- j. Lift up both ends of the clamp mechanism assembly and slide the complete unit out from the right-hand side of the machine. Be careful to hold the clamp section up to avoid damaging rubber inserts.

CAUTION

The X-Y mechanism will be free to slide back and forth on the rods. Hold the clamp mechanism when removing, so it does not slide and pinch fingers.

NOTE

The clamp is designed so that the rubber inserts can be easily replaced. They are made in 4 sections. Both outer replacement parts are held in fixed position by screws on the underside of the clamp. The position of the inner replacement strips is adjustable and held by screws accessible from the top of the plate.

The two outer strips should be assembled so that one part does not project beyond the other. There should be enough adjustment in the screw holes to allow for this type of alignment.

The inner strip should be adjusted so that the needle slot opening is 1/8 inch. This can be done by using the shank end of a 1/8 inch drill as a gauge. This gap must be maintained to minimize flagging of material, resulting in skipped stitches.

When adjusting the inner section of the rubber inserts, a small amount of clearance between the two must be maintained so that the vision

flap will work freely. Be sure to keep the gap between these inserts to a minimum.

The condition of the edge forming the needle slot of the replaceable strips is very important. Any nicks or rough edges could cause sewing problems and/or the unthreading of the needle during the return stroke.

The strips can be ordered as repair parts and should be replaced if the rubber becomes worn or torn.

k. If the machine is to be tilted back, remove the belt which runs from the machine to the electro-drive.

l. Reverse above procedure to reassemble unit. Locate the work plate by positioning it to the throat plate. It may be necessary to loosen the photocell and realign it to the hole in the work plate.

(6) Setting of electric clutch and gear box assembly is very important to a smooth clamp return. If for any reason the electric clutch has to be removed and the relative position of the gear box and the upper bearing block has been altered, assemble and align as follows.

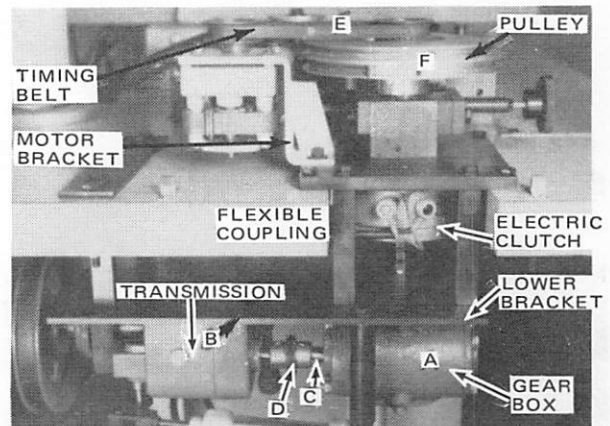

SETTING CLUTCH AND GEAR BOX

- a. Retighten the gear box (A) on the lower bracket (B), being sure the input shaft of the gear box is in line with the output shaft of the transmission (C). The flexible coupling (D) should not bind in any position.
- b. Remove the timing belt (E) by loosening the two screws at the base of the motor mounting bracket.
- c. Remove the 6 inch diameter double groove pulley (F) from the upper drive shaft, being careful not to lose or misplace the thrust bearings. Loosen the screw which prevents the clutch from rotating. This is the same screw that holds the grounding wire to the upper portion of the clutch.
- d. Remove the upper portion of the electric clutch by loosening the 2 set screws and lifting the upper drive shaft. Slide out the upper portion from the assembly.
- e. Loosen the 2 screws holding the lower splined hub which projects 1/4 inch above the gear box shaft.

f. Lower the upper drive shaft into the upper portion of the spline shaft freely.

g. If not, loosen the 3 hex head screws which hold the upper plate onto the spacer posts, and tap to align the upper plate until the upper drive shaft goes freely into the upper portion of the splined hub.

h. Retighten the 3 bolts, being sure that the shaft remains free in the splined hub. If not, repeat steps (e) through (h).

i. Lower the splined hub. Raise the upper drive shaft and reassemble the electric clutch.

j. Tighten the 2 set screws holding the electric clutch onto the upper drive shaft, being sure that the screws are seated on the flats.

k. Reassemble the 6 inch double groove drive pulley with thrust bearings in place. Take up the play between the clutch and the pulley to allow only .005 inch clearance.

l. Slide the splined hub and the clutch face up, allowing 1/64 inch clearance between the face of the clutch and the floating disc. Tighten the 2 hub screws with the key in place. Also tighten the grounding screw to prevent the upper portion of the clutch face rotating.

m. Replace the timing belt and reposition the small motor to leave a small amount of slack in the belt. Lock the motor in place.

n. Reassemble the unit on the table board and make all necessary connections with the electric cables, being sure that the green wire is connected to the metal grounding screw.

o. Assemble the cables, V belt, and airline to the backtack actuating cylinder. The unit should be ready to run.

NOTE

Use extreme caution to avoid getting any oil or grease on the clutch face surfaces.

(7) The backtack actuating cylinder on the drive assembly on the lower left end of the table actuates the backtack stitches. The cylinder is attached to a reversing stud on the transmission by a driving arm. The relative position of this driving arm to the reversing stud is important. If the lever has to be readjusted or slipped:

- Remove the air supply from the unit.
- Remove the clevis pin holding the reversing arm.
- Move the driving arm connected to the reversing stud to each extreme end of its travel. Check that the driving arm moves further in both directions than the maximum in and out stroke of the air cylinder.

d. If the above relationship does not exist, loosen the locking screw on the driving arm, rotating it on the reversing stud to get the same amount of travel on the driving arm, at both ends of its movement, relative to stroke of the air cylinder.

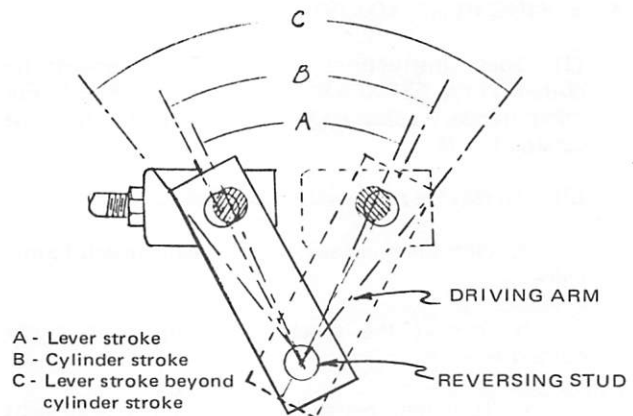

e. It is important that the vertical position of the driving arm on the stud is not changed so as to bind the clevis on the air cylinder.

f. When these adjustments have been made and all the screws tightened, replace the clevis and cotter pins.

(8) Setting 4 drive fingers on the underside of the clamp, which are used to move the material in programmed path:

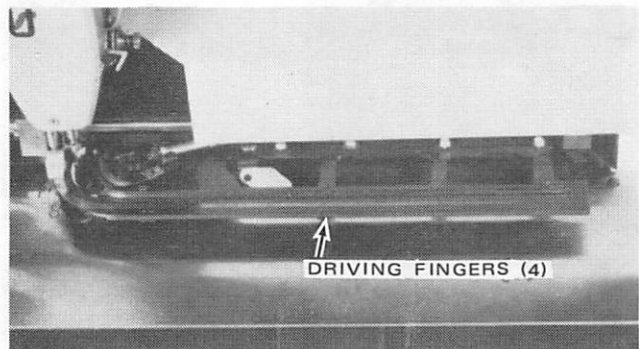

SETTING DRIVE FINGERS

- Place a pants panel under the clamp.
- With the main switch turned off and the main air supply disconnected, the clamp should be in the down position with the presser block resting on the clamp.
- Turn the adjusting screw on the first drive finger nearest the vision flap until the finger just contacts the material.
- Rotate the left cable drive pulley until the presser block is adjacent to the second drive finger, and adjust as the first one.

e. Continue this adjustment on all of the drive fingers.

f. Any drive fingers which are not on the material should be adjusted, so that they do not score the metal work surface.

K. SEWING HEAD ADJUSTMENTS

(1) These instructions are special adjustments required on the 63400 KBZ used on the 2800 E-2. For other standard adjusting information refer to machine catalog 121 M.

(2) To remove thread cutter and hook:

a. With the main switch OFF, remove belt to machine.

b. Remove the synchronizer plug from motor control box.

c. Turn main switch ON, so sewing machine light is on.

d. Remove two pan head screws holding the work surface in place and slide sheet out.

e. Remove throat plate. The right-hand throat plate screw is accessible through hole in vision flap when the vision flap is manually held closed.

f. Now both thread cutter and hook are accessible for adjusting or removal.

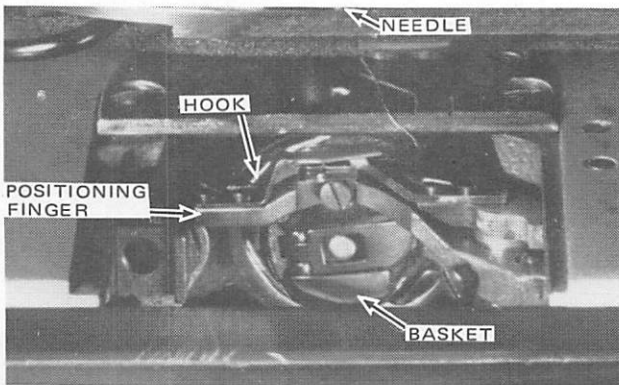

ROTATING HOOK ADJUSTMENT

(3) Adjusting the rotating hook assembly L-643A should be done with the work plate removed and the basket free to rotate and not interfere with the needle.

a. Install a new needle.

b. With the needle bar in the hook timing position, set the hook point so it just touches without deflecting the needle. Snug one of the screws on the hook to hold in this position.

c. Place a .004 shim between the hook hub and the loosened hook shaft collar and tighten the hook shaft collar in place using the 2 set screws.

d. Remove the .004 shim.

e. Loosen the screw which was tightened to hold the hook in place and move the hook back against the hook shaft collar.

f. Set the hook point to the center of the needle.

g. Rotate the hook basket and hold in place using the bobbin case holder positioning finger, maintaining a 1/32 inch opening between finger and basket recess.

NOTE

When the hook basket is in place, there will be a slight needle deflection as the needle reaches the bottom of its stroke, when the side of the needle point contacts the needle guarding surface of the basket. This is proper and correct. Do not make any modifications to the guarding surface on the hook basket without first referring to paragraph 4 following.

(4) Needle guarding surface L-643A (A), on the right side of the needle hole in the bobbin case holder (B), protects the hook point (C) from coming in contact with the needle (D) at looptaking time if needle is deflected toward the hook. With a properly adjusted hook, the needle guard is designed to deflect the needle slightly at the bottom of its travel. At looptaking time the needle should just contact the guard with no deflection. No material should ever be removed from this guarding section because that defeats the design. This guarding section is for size 16 needle.

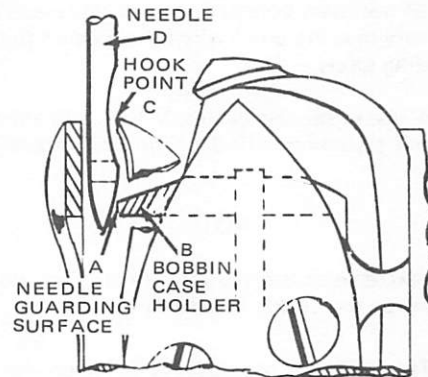

NEEDLE GUARD ADJUSTMENT

(5) The bobbin thread retainer (L-637A) spring holds both the bobbin thread and needle thread under slight tension, so the machine begins sewing with the first needle penetration. The bobbin thread retainer is adjustable up or down in the positioning finger. Adjust so that the threads are adequately pinched and held between the spring and the bottom of the moving Klipp-It knife. Keep the spring edges aligned at right angles to the positioning finger so the underneath angular portion of the moving knife does not strike the edges of the spring. If this occurs, the flat spring surface will not contact the lower surface of the moving knife sufficiently to clamp the threads.

Too much tension on the spring could cause thread breakage at the beginning of the sewing cycle and excessive deflection of the moving knife, affecting the trimming life of the knives.

NOTE

If backtacking is used or the machine stops directly on the material without sewing off, the needle thread tail will be pulled out of the bobbin thread retainer.

(6) Tension release adjustment:

a. Solenoid plunger pin (E) must touch tension release pin. The end of solenoid plunger pin must protrude a minimum of 1/32 inch to a maximum of 1/16 inch. If adjustment is required, move tension post assembly in or out.

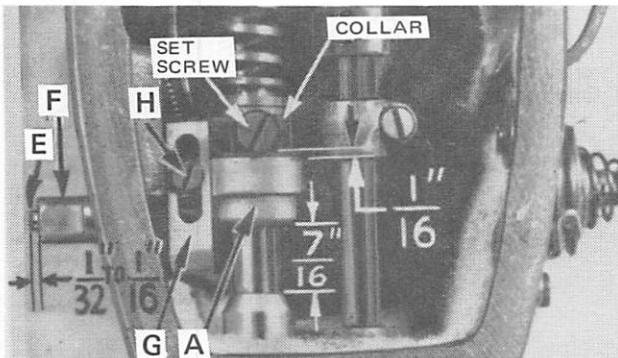

TENSION RELEASE ADJUSTMENT

b. Tension release solenoid is secured to flat of bushing (F) with a set screw in bracket. Solenoid plunger pin (E) must have approximately .005 inch clearance between it and the tension release pin without thread in the tension disc. Place a .005 inch spacer between the head of solenoid plunger pin and the end of tension release pin. Slip tension release solenoid onto bushing and move in until it contacts the solenoid plunger pin. Do not exert too much pressure and open the tension disc. After tightening set screw, remove spacer.

(7) For trimmer adjustments, remove the positioning finger and knife assembly from machine.

a. There should be no bind or shake in lower knife pivot carrier (A). Loosen screw (B) on the pivot release lever (C) and taking up the excessive end play or relieve the bind.

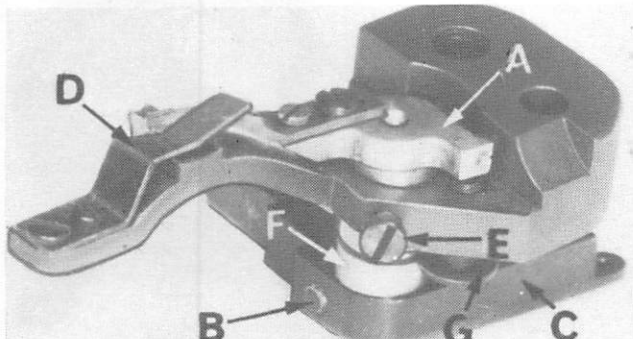

TRIMMER ADJUSTMENT

b. Position upper knife (D) parallel with the left side of the arm of the positioning finger. Check that lower knife is parallel with upper knife. If not, loosen the finger set screw (E) and turn the eccentric bushing (F) until the knives are parallel. A good starting point would be to have the pin hole in the eccentric bushing (F) located approximately 90° to the right side of the arm of the positioning finger.

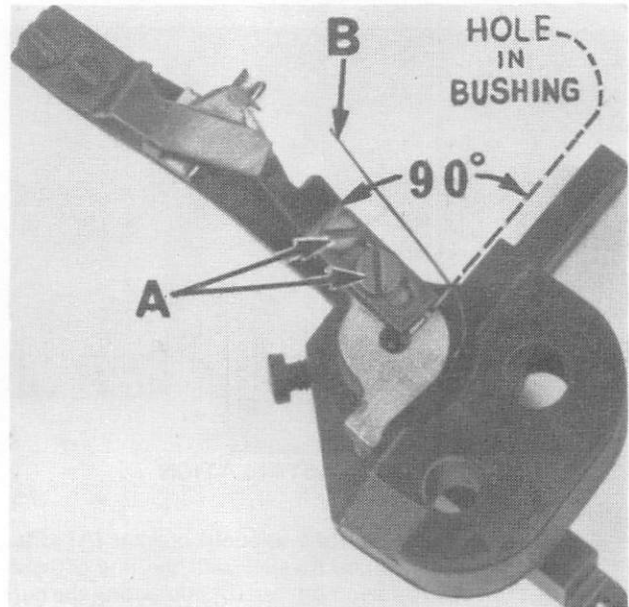

TRIMMER ADJUSTMENT

c. Adjust lower knife until it just contacts the upper knife. Turn flange screw (G) clockwise to lower knife and counterclockwise to raise it.

CAUTION

Be sure bushing is not turned while making this adjustment or parallel adjustment will have to be checked. The lower knife (A) in its extreme left position should not extend beyond the left side of the arm of the positioning finger (B). As the lower knife moves to the right, the run-out of the cutting edge (C) must coincide at a point of the positioning finger as indicated at point (D). To make adjustments, loosen screws (A) and position knife.

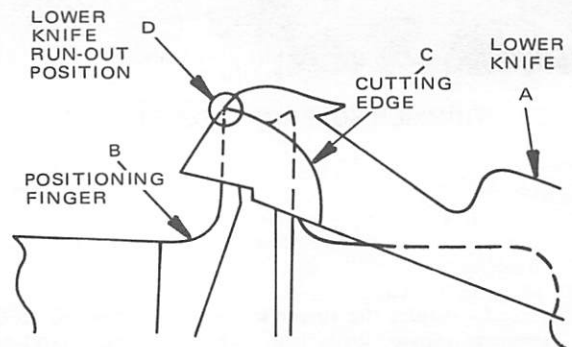

TRIMMER ADJUSTMENT

d. Assemble positioning finger and knife assembly into machine. Adjust the bobbin case holder positioning finger and knife assembly by turning the bobbin case holder until the finger recess is at the top. Place the projection (A) on the positioning finger into the bobbin case holder recess (B) and tighten the finger and knife assembly attaching screws securely, allowing 1/32 inch clearance between the outside edge of projection and the inside edge of bobbin case recess.

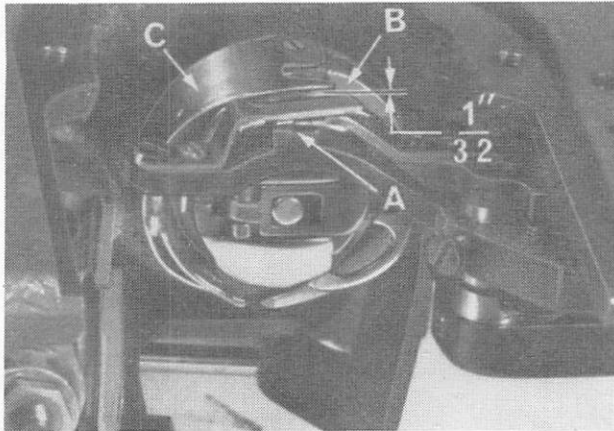

TRIMMER INSTALLATION

e. Locate the cutting solenoid bracket (A) as far forward as possible and parallel with the line of feed. With the cutting solenoid lever (B) contacting the cutting solenoid plunger (C), adjust the pivot release lever (D) so that 1/32 inch clearance is maintained when knife return spring (A) is in position.

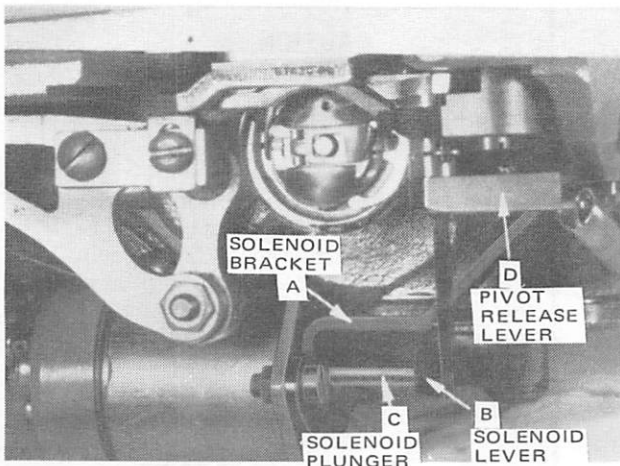

TRIMMER SOLENOID ADJUSTMENT

f. Adjust the lower knife stop screw (B) so that when the lower knife is in its extreme right hand position, the left corner (E) is in line with the left side of the needle slot in the bobbin case holder.

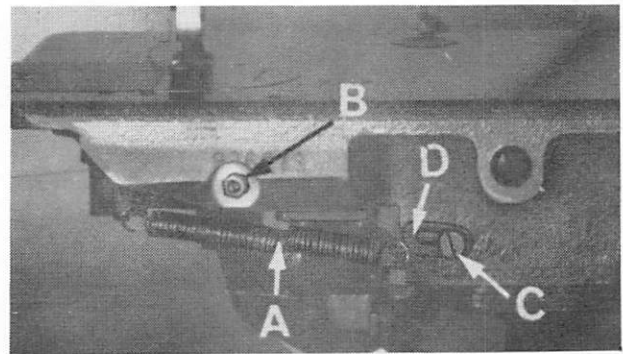

TRIMMER SOLENOID ADJUSTMENT

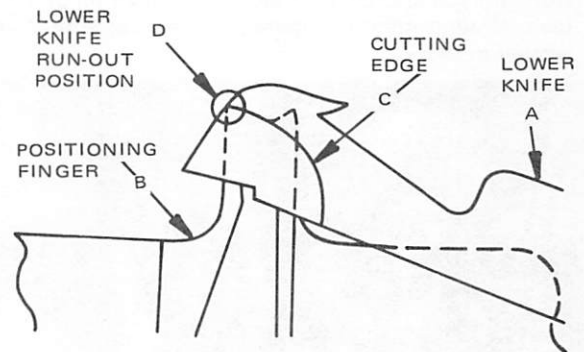

TRIMMER ADJUSTMENT

CAUTION

Be sure cutting solenoid lever contacts the lower knife stop when making this adjustment. Also be sure knife does not hit the hook point.

g. Be sure the spring retainer (B) contacts the bobbin case holder when the lower knife is in its extreme right hand position. If the spring wire does not make contact, bend retainer wire to suit.

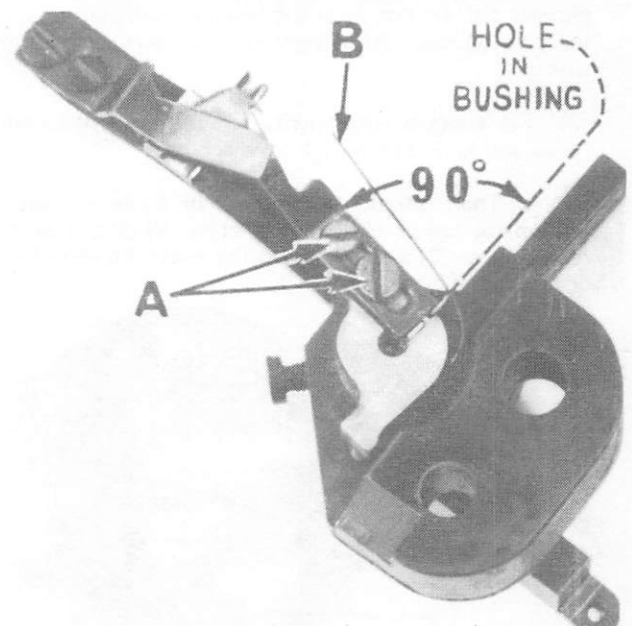

TRIMMER ADJUSTMENT

NOTE

If positioning finger assembly or cutting solenoid bracket are removed from machine or position changed, check step (f).

h. To adjust tension of knife return spring, loosen screw (C) and move tension spring bracket (D) right to increase tension or left to decrease tension.

(8) Assembling and adjusting synchronizer on Class 63400 KBZ installed with Quick Drive and needle positioner No. 800 ST-362 on 2800 E-2. The synchronizer is composed of three slip rings and four carbon brushes. Band A is fixed on the synchronizer and controls the cutting mechanism. Band B controls the needle up position. Band C controls the needle down position.

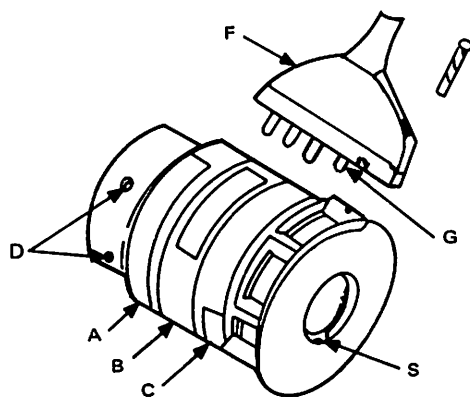

SYNCHRONIZER ADJUSTMENT

a. Assemble the brush holder to the bracket, as shown on diagram PL-586, and the synchronizer to the handwheel adaptor.

b. Turn off motor switch.

c. Loosen screw D.

d. Loosen screw S so bands B and C rotate freely.

e. Place gauge over synchronizer and position it so the bottom of the gauge fits on top of the brushes.

NOTE

All of the following adjustments are made with needle on the down stroke, hook point at 9:00 o'clock position, and handwheel held securely to prevent turning.

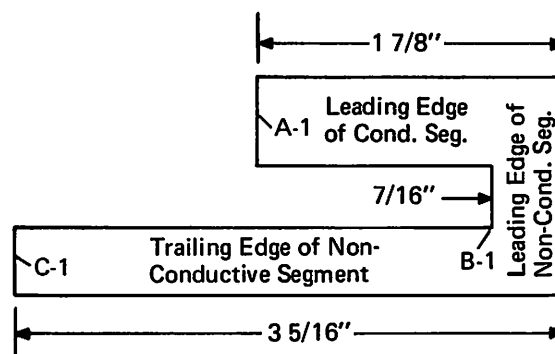

SYNCHRONIZER ADJUSTMENT GAUGE

f. Move the hub of the synchronizer in operating direction until start of the conducting strip on band A aligns with the edge of the gauge marked A-1.

g. Secure the synchronizer to the handwheel adaptor in this position by tightening screw D.

h. Move band B in operating direction until the starting edge of the non-conducting strip aligns with B-1 position on the gauge.

i. Holding band B in position, move band C in operating direction until the end of the non-conducting strip aligns with edge of gauge marked C-1.

j. Holding band B and band C in position, tighten screw S.

k. With bands A, B, and C set, the relationship between the cutting mechanism, the needle up position and the needle down position is set.

l. Check needle down setting. Remove throat plate and turn handwheel in operating direction until needle reaches its lowest position. Continue to turn until hook point has passed the needle by 5/64 inch. Non-conducting strip on band C should be on brush G.

m. Check needle-up setting. Turn handwheel in operating direction until the HOOK POINT IS AT 9:00 O'CLOCK WITH NEEDLE ON DOWN-STROKE. Start of non-conducting strip on band B should have passed the top of brush holder F by about 1/4 inch.

NOTE

If positioning finger assembly or cutting solenoid bracket are removed from machine or position changed, check step (f).

h. To adjust tension of knife return spring, loosen screw (C) and move tension spring bracket (D) right to increase tension or left to decrease tension.

(8) Assembling and adjusting synchronizer on Class 63400 KBZ installed with Quick Drive and needle positioner No. 800 ST-362 on 2800 E-2. The synchronizer is composed of three slip rings and four carbon brushes. Band A is fixed on the synchronizer and controls the cutting mechanism. Band B controls the needle up position. Band C controls the needle down position.

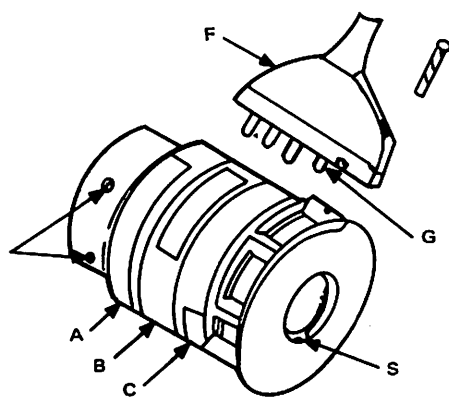

SYNCHRONIZER ADJUSTMENT

a. Assemble the brush holder to the bracket, as shown on diagram PL-586, and the synchronizer to the handwheel adaptor.

b. Turn off motor switch.

c. Loosen screw D.

d. Loosen screw S so bands B and C rotate freely.

e. Place gauge over synchronizer and position it so the bottom of the gauge fits on top of the brushes.

NOTE

All of the following adjustments are made with needle on the down stroke, hook point at 9:00 o'clock position, and handwheel held securely to prevent turning.

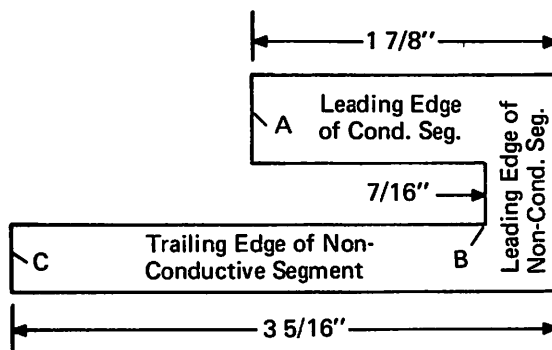

SYNCHRONIZER ADJUSTMENT GAUGE

f. Move the hub of the synchronizer in operating direction until start of the conducting strip on band A aligns with the edge of the gauge marked A-1.

g. Secure the synchronizer to the handwheel adaptor in this position by tightening screw D.

h. Move band B in operating direction until the starting edge of the non-conducting strip aligns with B-1 position on the gauge.

i. Holding band B in position, move band C in operating direction until the end of the non-conducting strip aligns with edge of gauge marked C-1.

j. Holding band B and band C in position, tighten screw S.

k. With bands A, B, and C set, the relationship between the cutting mechanism, the needle up position and the needle down position is set.

l. Check needle down setting. Remove throat plate and turn handwheel in operating direction until needle reaches its lowest position. Continue to turn until hook point has passed the needle by 5/64 inch. Non-conducting strip on band C should be on brush E.

m. Check needle-up setting. Turn handwheel in operating direction until the HOOK POINT IS AT 9:00 O'CLOCK WITH NEEDLE ON DOWN-STROKE. Start of non-conducting strip on band B should have passed the top of brush F by about 1/4 inch.

SECTION V GENERAL MAINTENANCE

A. CLEANING

(1) Twice daily remove lint from hook area. Accumulated lint will cause skipped stitches, thread breakage, and/or failure of the Klipp-It to cut properly. An air nozzle is provided on the unit to clean the lint.

a. Remove bobbin case and bobbin. Use air nozzle to blow inside the hook and upward to remove lint in needle guarding area.

b. Blow across top of hook and bottom of throat plate to remove lint that has collected on the bottom of the throat plate.

c. Blow off the Klipp-It knife area.

(2) Remove 2 top covers at least once a month and remove lint. Wipe rods with a clean oily rag.

(3) Remove and clean the brown filter element periodically by washing with spirits, kerosene, etc., and blowing dry with air. The white filter element from the larger filter unit should be replaced when it changes color.

(4) The synchronizer bands should be periodically cleaned with a dry cloth and if necessary a non-oily cleaning fluid. Do not use emery paper or any other abrasive material.

B. LUBRICATION

(1) Check the sewing head oil level daily by examining oil sight gauge and adding Union Special spec. 86 oil as required. See catalog No. 121 M for proper care and lubrication.

(2) Check the unit lubricator once a week. A setting of one drop of oil every 50 cycles of unit operation is sufficient for proper lubrication of the pneumatic system.

a. To fill the lubricator, you need not turn off the air pressure and remove the fill plug. The first turn of the fill plug vents the air pressure from the bowl.

b. Fill to top with SAE 10 or lighter oil to fill line.

c. Replace fill plug tightly. As soon as air pressure rebuilds inside the bowl, oil will drip through the sight gauge. Control the rate of oil entering the air stream by turning the adjustment screw. Turning in gives less oil and out gives more.

NOTE

From OFF to FULL OPEN requires only 2 turns of the adjusting screw. Turning it out further serves no purpose. NEVER take out adjusting screw while the air pressure is on.

d. Periodically clean adjusting screw needle valve and seat and the small felt filter by swishing in a cleaning fluid and blowing off with air.

e. Drain off any contaminants or water in the bottom of the bowl.

(3) The gear reducer contains the proper amount of Texaco Pinnacle Cylinder Oil (a Texaco product) from the factory. This oil should be replaced after the first 30 days (8 hours daily) of unit operation. After this initial oil change, the oil should be changed about every 6 months (8 to 10 hours duty).

Some reducers have grease fittings at the upper bearings. They should be lubricated with Texaco Multifax EP Grease, or equal, after each 200 hours of operation.

NEVER OVERFILL THE GEAR REDUCER WITH OIL. It will cause oil leakage and overheating, resulting in rapid wear of oil seals, bearings and gears. The oil should be filled to the oil level plug or gauge and never any higher.

(4) The transmission drive runs in oil and is filled with the proper amount and kind at the factory. All drives are permanently lubricated. However, the oil level should be checked periodically to be sure the case is at least 1/2 full. When necessary, fill through hole in housing with transmission No. 400 lubricant or SAE 40 detergent motor oil.

(5) Idler pulley bearings on top right side of cam plate should be greased every 6 months. Zerk fitting is on the bearing housing.

(6) Drive pulley bearings underneath the left-hand drive pulley require a thin coat of cup grease every 6 months.

(7) The electro-drive should be cleaned and greased every 2 years.

C. REPLACEMENT

(1) Replace 2 carbon brushes (998-237) on the Quick Auxiliary Drive every 12 months.

(2) Replace round belt (998-235) on Quick Drive every 12 months.

(3) Check synchronizer carbon brushes every 12 months and replace as required.

(4) A check list follows this section, to be used when a service or inspection call is made. We recommend that plant mechanics use this check list when the unit is inspected periodically. A good maintenance program will prevent unnecessary downtime.

UNIT CLEANING, LUBRICATION, AND REPLACEMENT PROGRAM

PART	WEEKLY	MONTHLY	6 MONTHS	1 YEAR
CHECK CONDITION AND/OR CLEAN				
Clamp Rubber	X			
Rotary Hook	X			
Throat Plate	X			
Air Tubes to Clamp	X			
Trimming Knives		X		
Bobbin Thread Spring		X		
Wire Cables		X		
Synchronizer			X	
Vee Belts			X	
CLEAN AND LUBRICATE				
Air Filter & Regulator	X			
Cam Plate		X		
Cam Roller		X		
X-Y Rods		X		
Transmission			X	
Gear Box			X	
REPLACEMENT				
Aux. Motor Brushes				X
Synchronizer Brushes				X
Round Belt on Quick Drive				X

1

SECTION VI
PARTS LISTS

REF NO	PART NO	DESCRIPTION	AMT REQ
1	RM-3417	Bobbin Motor Assembly	1
2	61377J	Pulley Shaft	
3	RM-2748A	Switch SPST	1
4	RM-3376	Switch	1
5	RM-3627	Switch	1
6	RM-3443	Knob	3
7	RM-3402	Stainless Steel Table	1
8	61477C	Tension Bracket	1
	109	Tension Disc	2
	61392F-14	Tension Spring	1
	612926	Tension Nut	1
9	RM-3312-1	Filter	1
10	660-398	F.R.O. Combo	1
11	RM-3343	Right Cover	1
12	998-264	Bobbin Switch	1

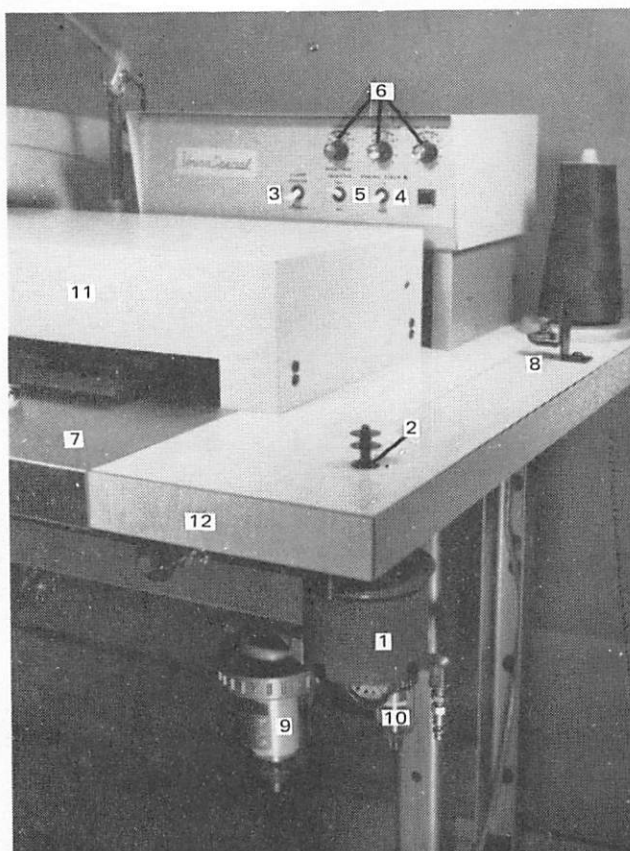

REF NO	PART NO	DESCRIPTION	AMT REQ
1	RM-3349	Cutting Solenoid	1
2	L-643A	Rotating Hook Assembly	1
3	L-639A	Needle Bar	1
4	RM-2385D	Throat Plate	1
5	L-637A	Bobbin Thread Retainer	1
6	L-636A	Bobbin Thread Holder Positioning Finger	1
7	51292F-5	Spring	1
8	RM-3494	Throat Plate Screw	2

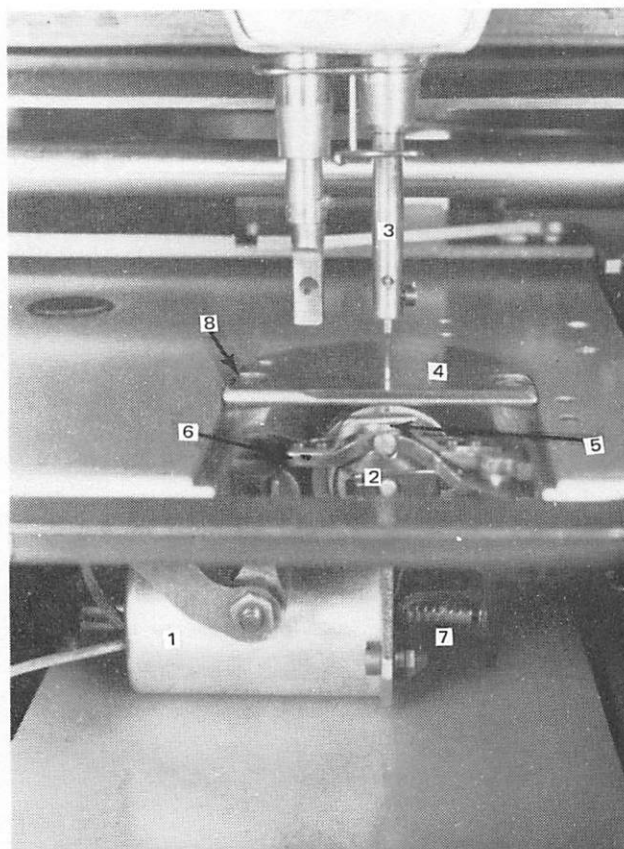

SECTION VI
PARTS LISTS

REF NO	PART NO	DESCRIPTION	AMT REQ
1	RM-3417	Bobbin Motor Assembly	1
2	61377J	Pulley Shaft	
3	RM-2748A	Switch SPST	1
4	RM-3376	Switch	1
5	RM-3627	Switch	1
6	RM-3443	Knob	3
7	RM-3402	Stainless Steel Table	1
8	61477C	Tension Bracket	1
	109	Tension Disc	2
	61392F-14	Tension Spring	1
	612926	Tension Nut	1
9	RM-3312-1	Tension Filter	1
10	660-398	F.R.O. Combo	1
11	RM-3343	Right Cover	1
12	998-264	Bobbin Switch	1

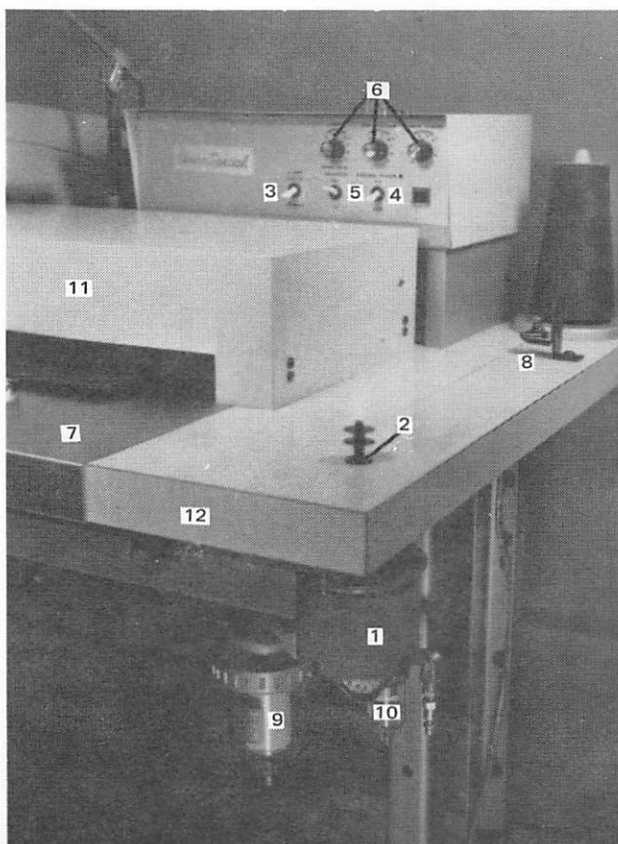

REF NO	PART NO	DESCRIPTION	AMT REQ
1	RM-3349	Cutting Solenoid	1
2	L-643A	Rotating Hook Assembly	1
3	L-639A	Needle Bar	1
4	RM-2385D	Throat Plate	1
5	L-637A	Bobbin Thread Retainer	1
6	L-636A	Bobbin Thread Holder Positioning Finger	1
7	51292F-5	Spring	1
8	RM-3494	Throat Plate Screw	2

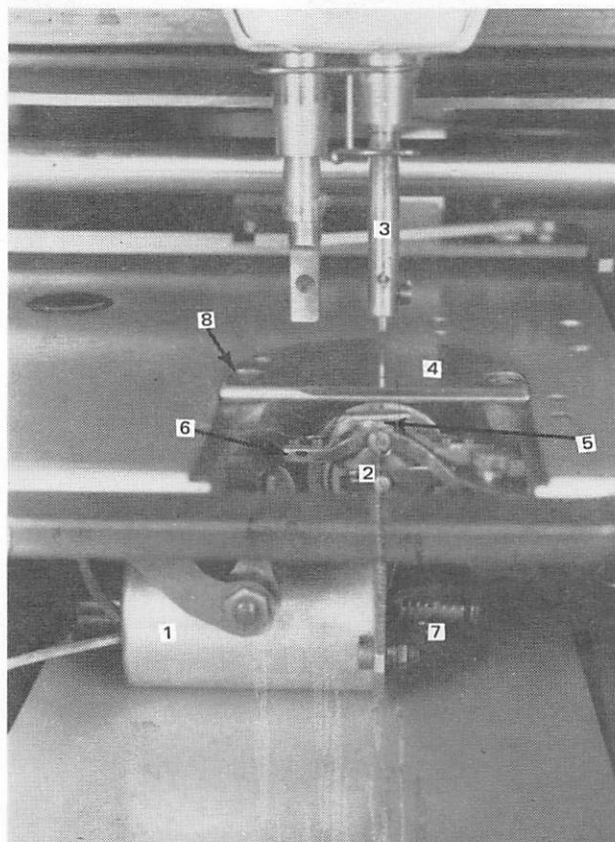

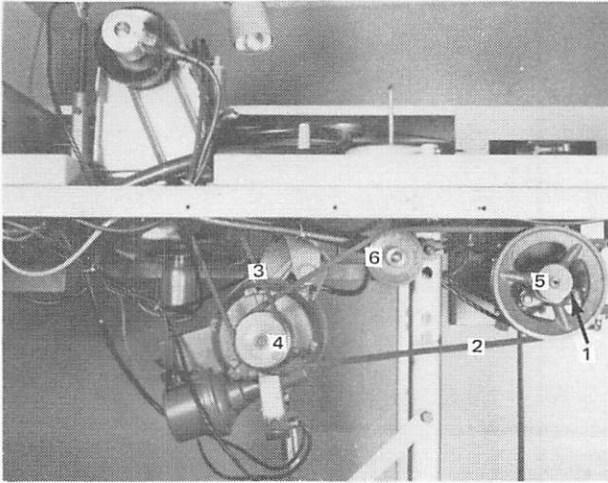

REF NO	PART NO	DESCRIPTION	AMT REQ
1	RM-3600	Vee Belt Sheave Idler	1
2	21262H-450	Vee Belt 1/2"	1
3	21261M-410	Vee Belt 3/8"	1
4	RM-2836	Pulley	1
5	RM-2838D	6" Dia. Pulley	1
6	RM-2520	Input Shaft	1

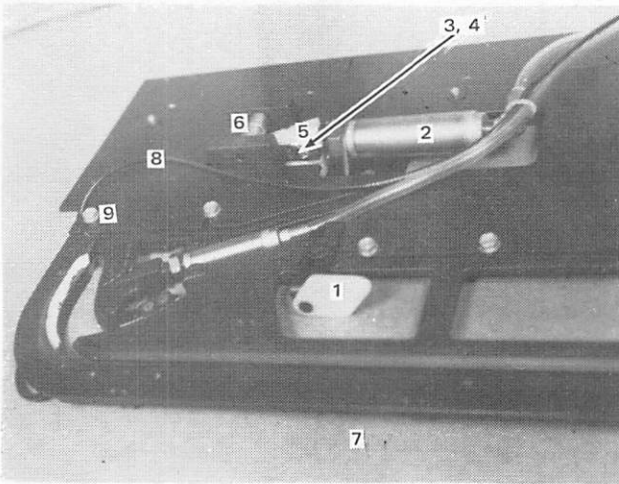

REF NO	PART NO	DESCRIPTION	AMT REQ
1	RM-3080D	Garment Stop	1
2	RM-2874D	Cylinder	1
3	RM-3674	Lift Wedge Clevis	1
4	RM-3675	Lift Wedge Pivot	1
5	RM-3676	Lift Wedge	1
6	478-12	Bearings	2
7	RM-2606D	Clamp Plate	1
8	RM-2980B	1/8" Tubing	1
9	RM-3046D	71" Long No. 10-32 x 5/16 H.H. Sems	6

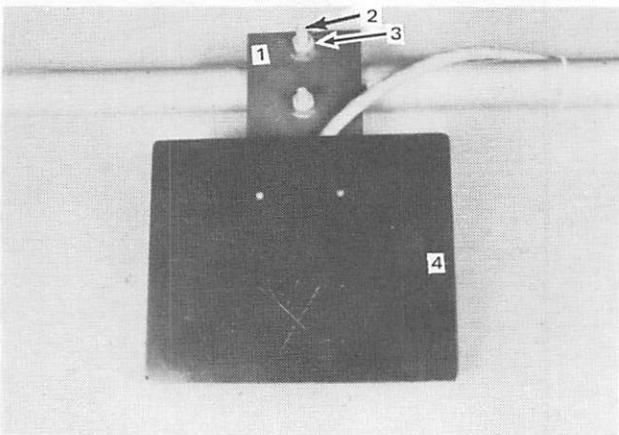

REF NO	PART NO	DESCRIPTION	AMT REQ
1	RM-3450	Switch Plate	1
2	RM-3460	1-3/8 U Bolt	1
3	RM-3211-3	w/Nuts	2
4	RM-3525	3/8-16 H.N.	1
5	RM-3611	Start Switch Treadle Plate	1
6	22652A-6	Start Switch Assembly (Not Shown)	1
		8-32 x 3/8 S.H.S.	5

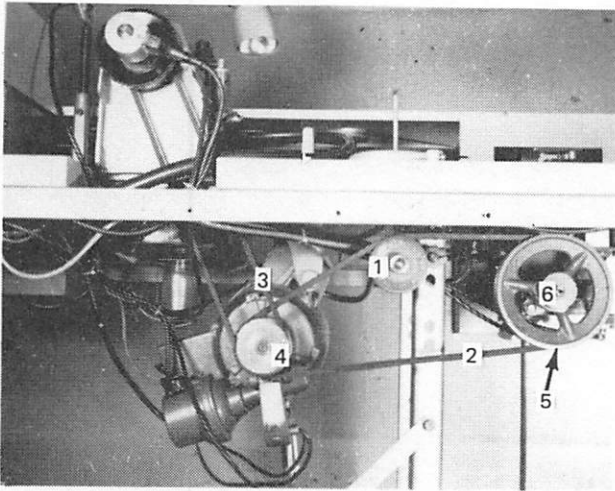

REF NO	PART NO	DESCRIPTION	AMT REQ
1	RM-3600	Vee Belt Sheave Idler	1
2	21262H-450	Vee Belt 1/2"	1
3	21261M-410	Vee Belt 3/8"	1
4	RM-2836	Pulley	1
5	RM-2838D	6" Dia. Pulley	1
6	RM-2520	Input Shaft	1

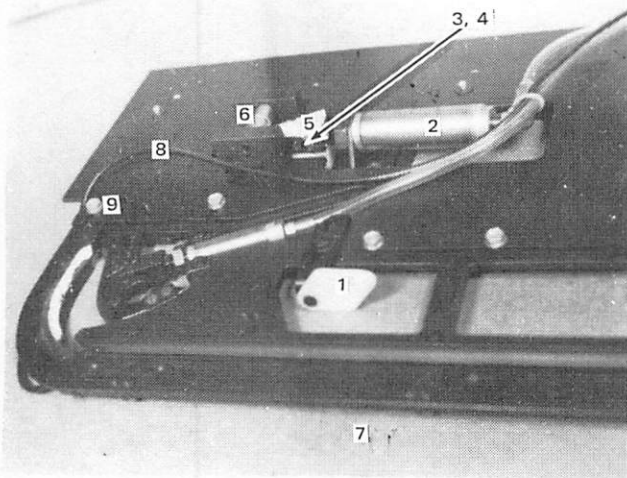

REF NO	PART NO	DESCRIPTION	AMT REQ
1	RM-3080D	Garment Stop	1
2	RM-2874D	Cylinder	1
3	RM-3674	Lift Wedge Clevis	1
4	RM-3675	Lift Wedge Pivot Screw	1
5	RM-3676	Lift Wedge	1
6	478-12	Bearings	2
7	RM-2606D	Clamp Plate	1
8	RM-2980B	1/8" Tubing 71" Long	1
9	RM-3046D	No. 10-32 x 5/16 H.H. Sems	6

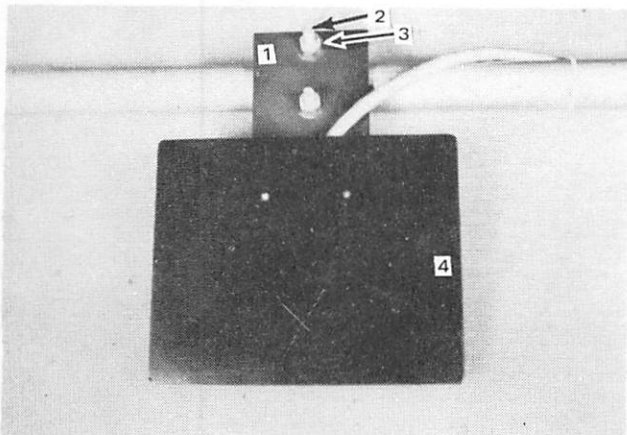

REF NO	PART NO	DESCRIPTION	AMT REQ
1	RM-3450	Switch Plate	1
2	RM-3460	1-3/8 U Bolt w/Nuts	1
3	RM-3211-3	3/8-16 H.N.	2
4	RM-3525	Start Switch Treadle Plate	1
5	RM-3611	Start Switch Assembly (Not Shown)	1
6	22652A-6	8-32 x 3/8 S.H.S.	5

REF NO	PART NO	DESCRIPTION	AMT REQ
*1	RM-3612	Transformer	1
2	RM-2737A	Fuse Holder	3
3	RM-3048-3	.3 Amp 3 AG Fuse	1
4	RM-3048-3	.3 Amp 3 AG Fuse	1
5	RM-3048-4	3. Amp Fuse	1
6	RM-2748A	Switch SPST (Clamp)	1
7	RM-3376	Switch DPST Main	1
8	RM-3627	Switch 2PDT (Backtack)	1
9	RM-3088-8	500 K Pot (Backtack)	1
10	RM-3088-7	50K Pot Stop Position	1
11	RM-3088-3	100K Pot Stop Position "Piggy Back"	1
12	RM-3088-4	350K Pot Bobbin	1
13	RM-2749A	Pilot Lite	1
14	RM-3619	Control Logic Printed Circuit Board	1
15	RM-3620	Power PC Board	1

*Not shown (located under control box)

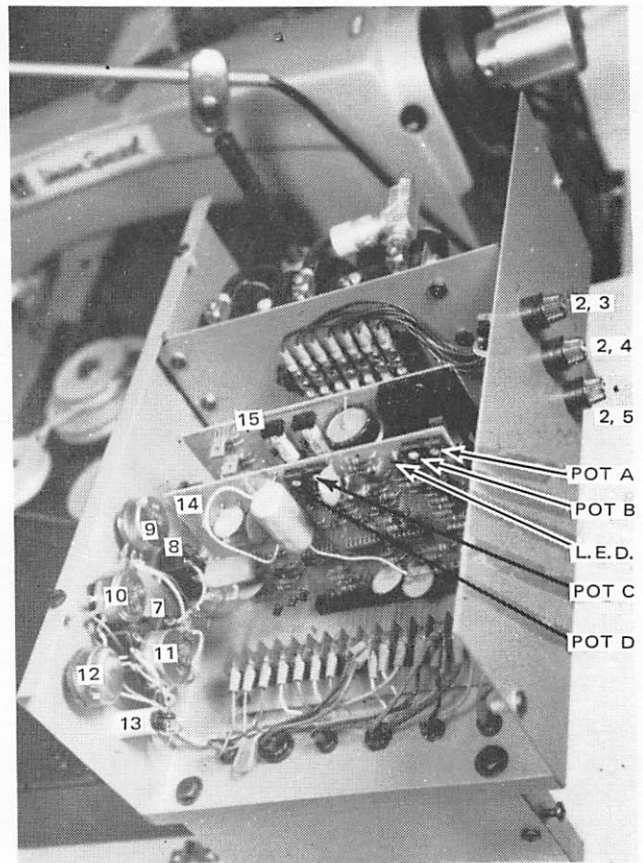

REF NO	PART NO	DESCRIPTION	AMT REQ
1	RM-3406	Cylinder Bracket	1
2	671 A-1	Cylinder	1
3	RM-3316	Cylinder Rod End	1
4	RM-3410	Quick Motor Modified	1

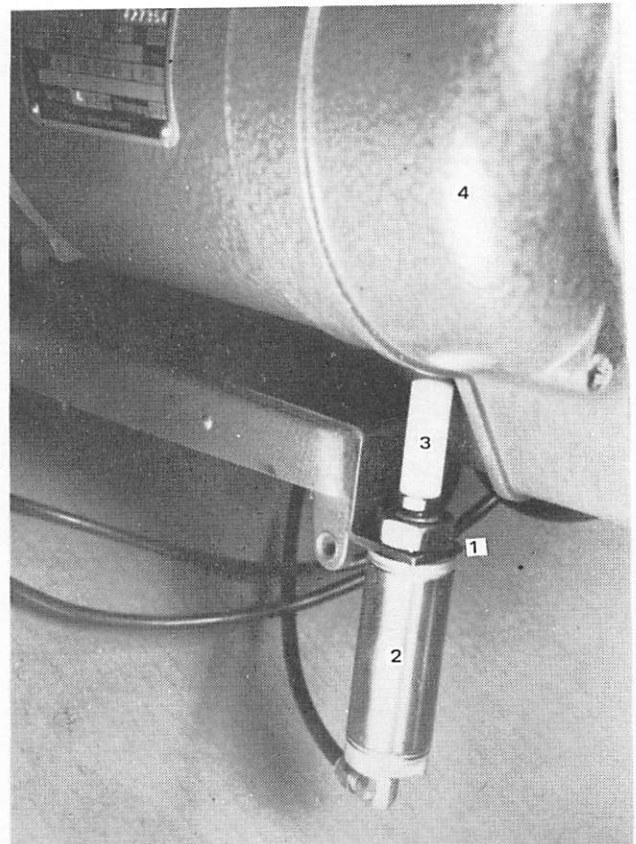

REF NO	PART NO	DESCRIPTION	AMT REQ
1	RM-3612	Transformer	1
2	RM-2737A	Fuse Holder	3
3	RM-3048-3	.3 Amp 3 AG Fuse	1
4	RM-3048-3	.3 Amp 3 AG Fuse	1
5	RM-3048-4	3. Amp Fuse	1
6	RM-2748A	Switch SPST (Clamp)	1
7	RM-3376	Switch DPST Main	1
8	RM-3627	Switch 2PDT (Backtack)	1
9	RM-3088-8	500 K Pot (Backtack)	1
10	RM-3088-7	50K Pot Stop Position	1
11	RM-3088-3	100K Pot Stop Position "Piggy Back"	1
12	RM-3088-4	350K Pot Bobbin	1
13	RM-2749A	Pilot Lite	1
14	RM-3619	Control Logic Printed Circuit Board	1
15	RM-3620	Power PC Board	1

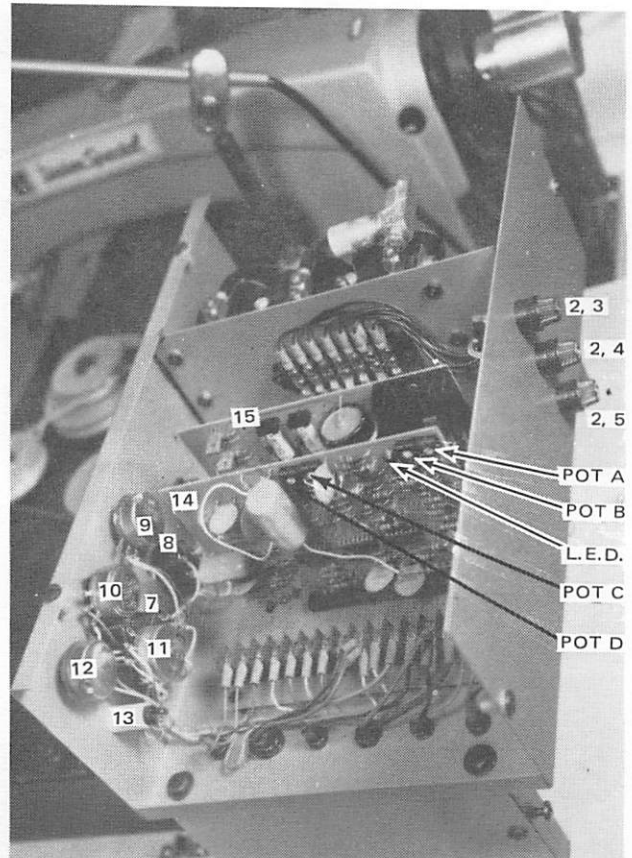

REF NO	PART NO	DESCRIPTION	AMT REQ
1	RM-3406	Cylinder Bracket	1
2	671 A-1	Cylinder	1
3	RM-3316	Cylinder Rod End	1
4	RM-3410	Quick Motor Modified	1

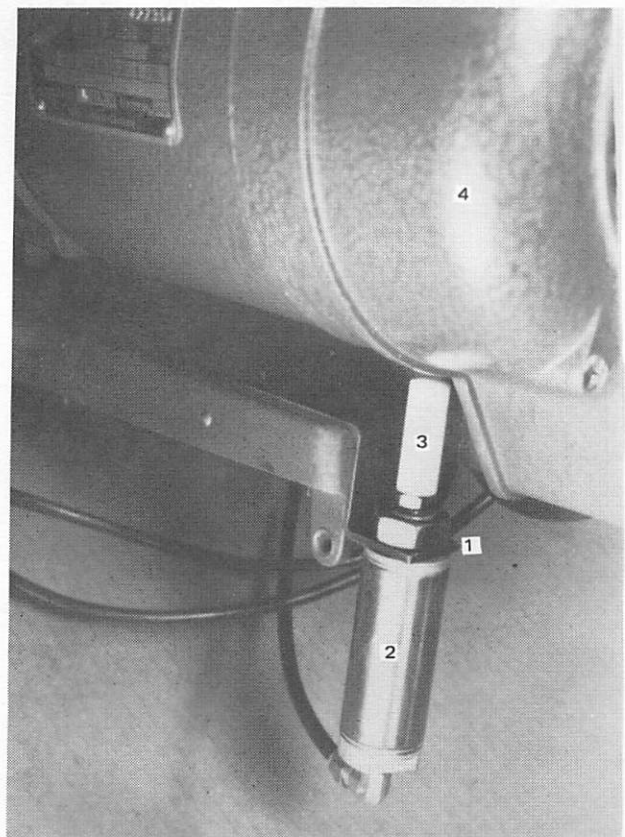

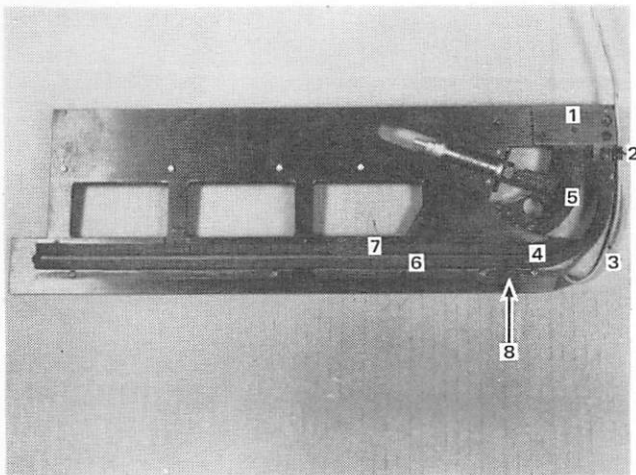

REF NO	PART NO	DESCRIPTION	AMT REQ
1	RM-2618D	Vision Flap Pivot	1
	RM-3492-1	6-32 x 1/4 F.H.S.	2
2	RM-3305-2	1/8" Cable Clamp	1
3	RM-2980B	Tubing	1
4	RM-3377	Outer Curved Rubber Strip	1
5	RM-3436	Vision Flap Rubber Strip	1
6	RM-3333	Outer Rubber Strip	1
7	RM-3446	Inner Rubber Strip	1
8	RM-3015D	Spring Clips	4
	RM-3034D	Spring Clips	4
	87U	Mounting Spacer .124-50 x 3/16 Fil. H.S.	8

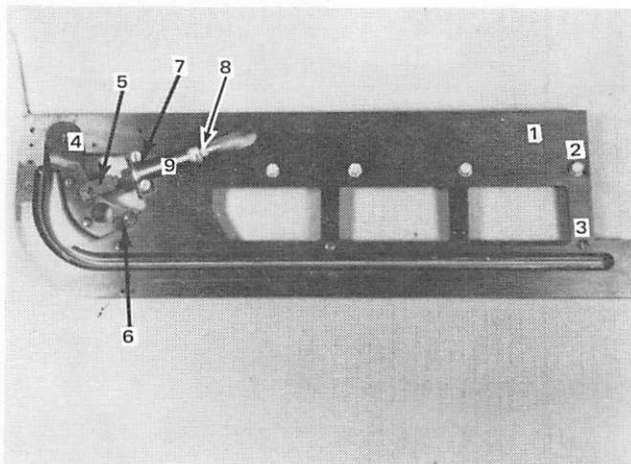

REF NO	PART NO	DESCRIPTION	AMT REQ
1	RM-2606D	Clamp Plate	1
2	RM-3046D	10-32 x 5/16 H.H. Sems	6
3	22635C-12	6-32 x 3/16 R.H.S.	5
4	RM-2608D	Vision Plate	1
5	RM-2531D	Vision Plate Clevis	1
6	RM-2615D	Vision Plate Guide	2
	22561	124-50 x 9/64 Fil. H.S.	4
7	RM-2612D	Cylinder Mounting Bracket	1
	22585A	146-40 x 5/16 Fil. H.S.	2
8	RM-2965	Hose Fitting with Gasket	1
9	RM-2974B	Cylinder	1

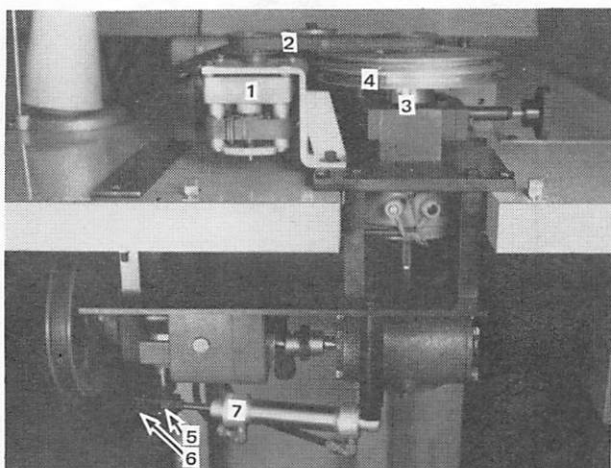

REF NO	PART NO	DESCRIPTION	AMT REQ
1	RM-3521	Carriage Return Motor	1
2	RM-3557-1	Timing Belt	1
3	RM-2998-1	Thrust Bearing	1
4	RM-3257D	Screw Pin Bumper	1
5	RM-2558	Clevis	1
6	RM-2559	Reversing Lever	1
7	RM-3535	Cylinder	1

REF NO	PART NO	DESCRIPTION	AMT REQ
1	RM-2852B	Flow Control Valve	3
	A. Clamp Lift		1
	B. Presser Foot		1
	C. Vision Flap		1
2	RM-3634-1	3 Way Valve	3
3	RM-3634-2	4 Way Valve	2
4	RM-3319-1	Throttle Valve Thread Wiper	1

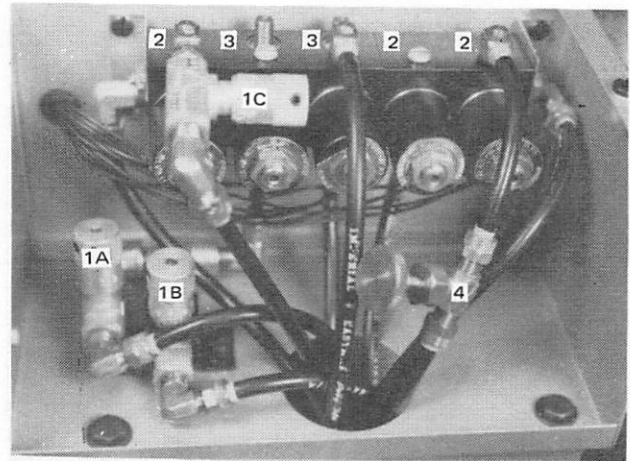

REF NO	PART NO	DESCRIPTION	AMT REQ
1	RM-3608	Return Wire Rope Assembly	1
2	RM-2596D	Lefthand Wire Rope	1
3	RM-3124D	1/4" Ball Bushing	4
	RM-2798-1	1/4" Ball Bushing Retaining Ring	8
4	RM-2606D	Clamp Plate	1
5	RM-3122D	1/4" Dia. Shaft	2
6	RM-3126D	1/2" Ball Bushing	4
	RM-3129D	1/2" Ball Bushing Retaining Ring	8
7	RM-3123D	1/2 Dia. Shaft	2
8	RM-2539D	Cable Pivot Stud	1
9	RM-3561	Cam Plate	1
10	RM-2514D	Cam Pulley	1
11	RM-2693D	Cam Pulley Return Spring	1
12	RM-2518D	Tracking Pulley	3
13	RM-2541D	Cam Roller	1
14	RM-2540D	Cable Pivot	2
15	22652D-12	1/4-20 x 3/4 S.H.S. Washer	4
	RM-3068D		4

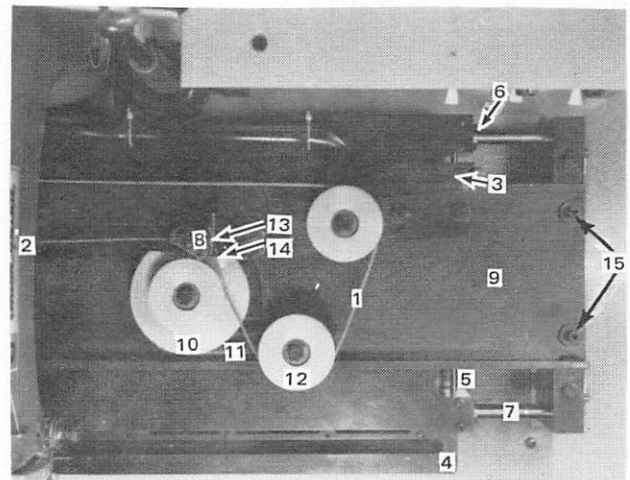

REF NO	PART NO	DESCRIPTION	AMT REQ
1	RM-3542-1	Pulley	2
2	RM-3562	Drive Pulley	1
3	RM-3127D	Leaf Switch	1
	RM-2855D	Switch Cover	1
4	RM-3127D	Leaf Switch	2
	RM-2855D	Switch Cover	2
5	RM-2846D	Stop Adjusting Knob	1
6	RM-3402	Stainless Steel Table	1

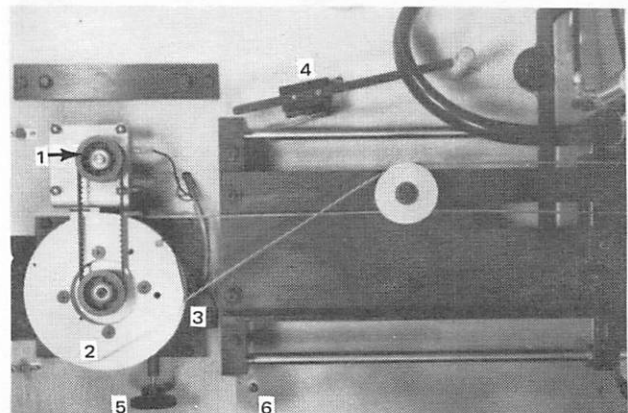

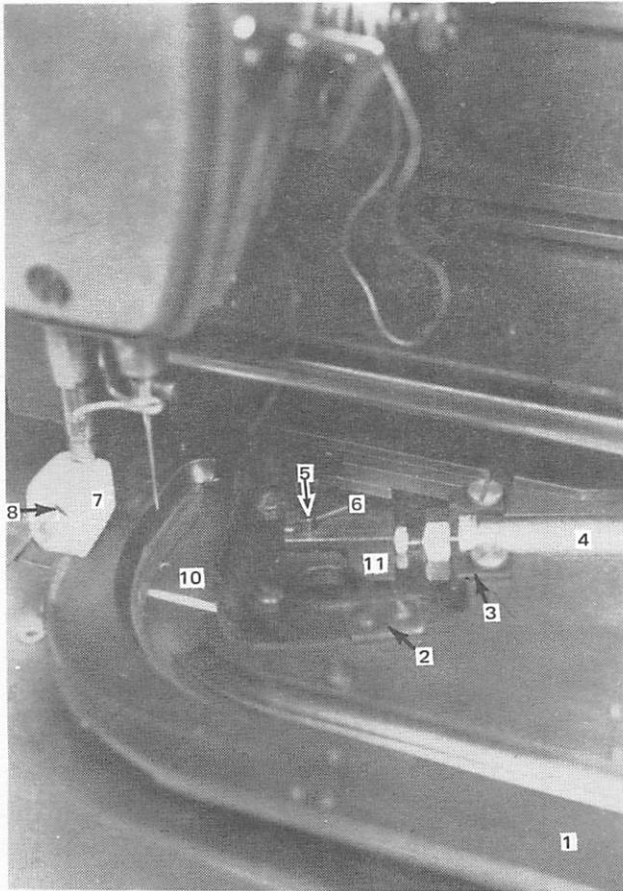

REF NO	PART NO	DESCRIPTION	AMT REQ
1	RM-2606D	Clamp Plate	1
2	RM-2615D	Vision Flap Guide	2
3	RM-2612D	Cylinder Mounting Plate	1
4	RM-2974B	Cylinder	1
5	RM-3054B	Clevis Pin	1
6	660-142	Cotter Pin	1
7	RM-3350	Clamp Block	1
8		Screw	1
9	RM-2608	Vision Flap	1
10	RM-2385D	Throat Plate	1
11	RM-2531D	Clevis	1
12	RM-3494	Screws for RM-2385D	2

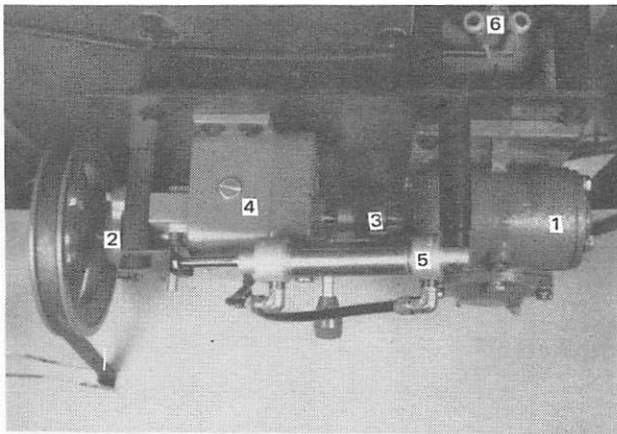

REF NO	PART NO	DESCRIPTION	AMT REQ
1	RM-3520	Speed Reducer	1
2	RM-3407-1	Flange Bearing	1
3	RM-3536-1	Flexible Coupling	1
4	RM-3522	Transmission	1
5	RM-3535	Cylinder	1
6	RM-2847D	Electric Clutch	1

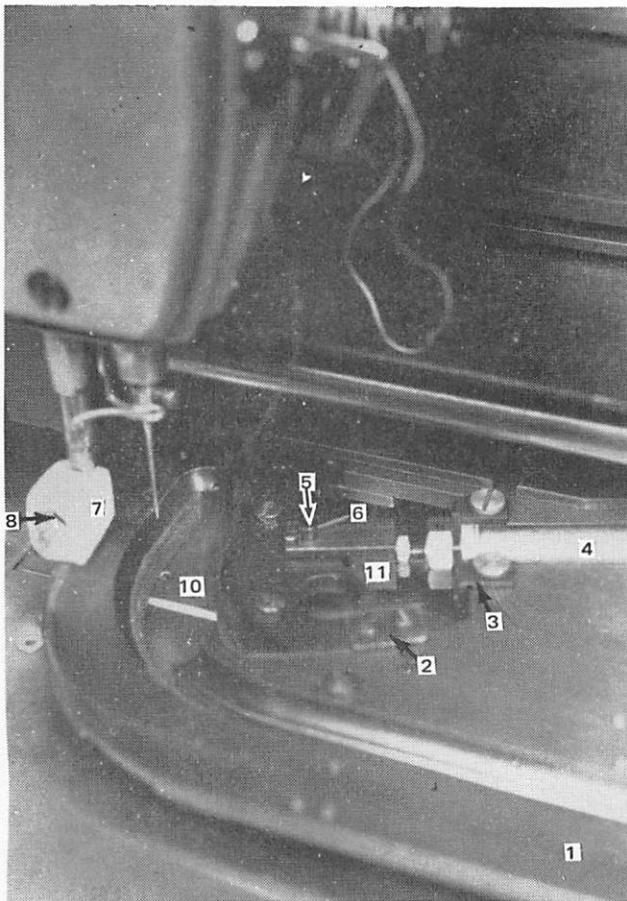

REF NO	PART NO	DESCRIPTION	AMT REQ
1	RM-2606D	Clamp Plate	1
2	RM-2615D	Vision Flap Guide	2
3	RM-2612D	Cylinder Mounting Plate	1
4	RM-2974B	Cylinder	1
5	RM-3054B	Clevis Pin	1
6	660-142	Cotter Pin	1
7	RM-3350	Clamp Block	1
8	22585-A	Screw	1
9	RM-2608	Vision Flap	1
10	RM-2385D	Throat Plate	1
11	RM-2531D	Clevis	1
12	RM-3494	Screws for RM-2385D	2

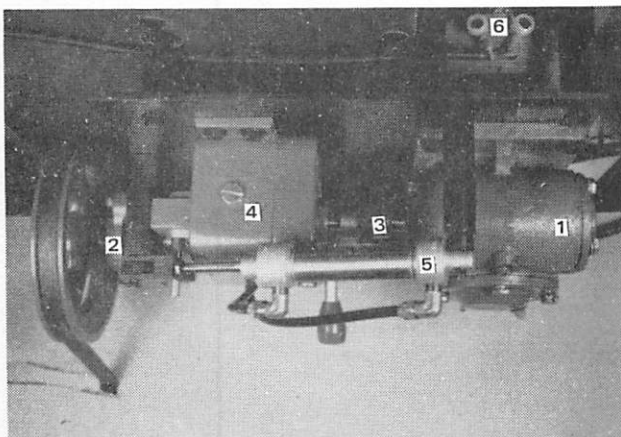

REF NO	PART NO	DESCRIPTION	AMT REQ
1	RM-3520	Speed Reducer	1
2	RM-3407-1	Flange Bearing	1
3	RM-3536-1	Flexible Coupling	1
4	RM-3522	Transmission	1
5	RM-3535	Cylinder	1
6	RM-2847D	Electric Clutch	1

REF NO	PART NO	DESCRIPTION	AMT REQ
1	RM-3127D	Leaf Switch	1
2	RM-2855D	Switch Enclosure	1
3	660-245	Retaining Ring	1
4	660-397	Cylinder	1
5	RM-3347	Cylinder Clevis	1
6	RM-3484	Plastic Tube	1
7	RM-3238D	Bed Positioning Spring (Mod.)	1
	RM-3121D	Machine Positioner	1
8	RM-2813-3	8-32 x 3/8 B.H.S.	1
9	RM-3357	Switch Spacer	2
	RM-2805-1	Switch Mounting Screws	2

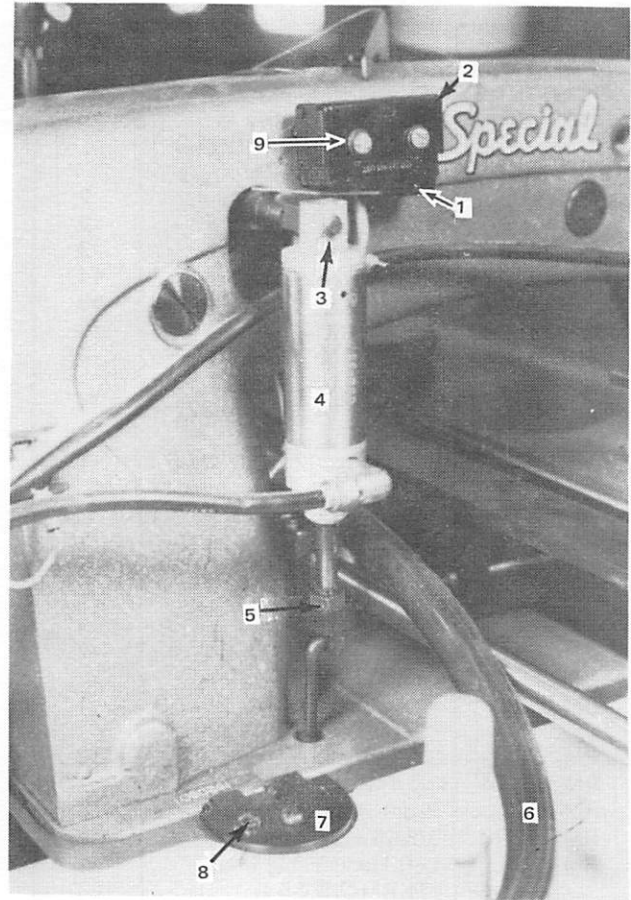

2800 E-2 COMPLETE PARTS LIST

TABLE ASSEMBLY

PART NO	DESCRIPTION	AMT REQ
21371UR	Top Leg Assembly (8 RM-2827-7, RM-3211-3 and 16 652-L-24)	2
21371WE	Left Hand Side Plate	2
21371WF	Right Hand Side Plate	2
51-214 BLK	Spacer	2
RM-2827-7	3/8-16 x 2-1/4 H.H.S.	14
652-L-24	Washer	38
RM-3211-3	3/8-16 H.J.N.	18
21371UK	Feet (4 RM-2827-7, 4 RM-3211-3, & 8 652-L-24)	4
21371UL	Treadle Pipe (2 RM-2827-7 and 2 652-L-24)	1
21371UM	Back Brace (2 RM-2827-5, 2 RM-3211-3 & 4 652-L-24)	1
RM-3342	Angle Brace (4 RM-2827-5, 4 RM-3211-3 & 8 652-L-24)	2
RM-2827-5	3/8-16 x 3/4 H.H.S.	14
RM-3643	Rear Angle (6 RM-2827-5 and 6 RM-3293-3)	1
RM-3336	Front Angle (4 RM-2827-8, 2 3293-4 & 4 RM-3293-3)	1
RM-3293-3	3/8 F.W.	12
RM-3293-4	1/2 F.W.	2
RM-3338	Front Angle Spacer	4
RM-2827-8	3/8-16 x 3-1/2 H.H.S.	4
RM-3559	Left Hand Table Board (1 RM-2827-5 & 1 RM-3293-3)	1
RM-3564	Right Hand Table Board (1 RM-2827-5 & 1 RM-3293-3)	1
RM-3493	Neoprene Bumper	1
NA-13	4-D Nail	2

DRIVE ASSEMBLY

PART NO	DESCRIPTION	AMT REQ
RM-3410	Main Motor Modification (3 22605 from 29480 GU)	1
652-L-24	Washer	3
RM-2836	Double Groove Pulley	1
22650CD-6	1/4-20 x 3/8 S.S.S.	1
RM-3406	Cylinder Bracket	1
22652A-6	No. 8-32 x 3/8 S.H.S.	2
RM-3293-5	No. 8 F.W.	1
671A-1	Single Acting Cylinder	1
RM-3211-2	5/16-24 H.J.N.	1
RM-3316	Cylinder Rod End Clutch	1
660-401	Male Elbow	1
RM-2997D	Polyflo Tubing 42" Long	1
RM-3489	Light Fixture Extension Cable Assembly	1
29480 GU	Installation Kit (Return to stock 2-660-204, 2-660-356, 3-660-352, 3-95304 & 6 SC333A)	1

DRIVE ASSEMBLY (continued)

PART NO	DESCRIPTION	AMT REQ
998-251	Auxiliary Control	1
RM-2791-1	No. 10 x 1 P.H.S.M.S. 1-660-356 Cable Clamp & 1 SC333A from 29480 GU	2

IDLER PULLEY ASSEMBLY

PART NO	DESCRIPTION	AMT REQ
RM-3598	Idler Mounting Stud	1
RM-3293-4	1/2 F.W.	1
21818B	1/2-13 H.N.	1
RM-3599	Single Adjusting Tightener	1
RM-3600	"V" Belt Sheave Idler	1

ELECTRIC CLUTCH & TRANSMISSION ASSEMBLY

PART NO	DESCRIPTION	AMT REQ
RM-2521	Drive Mechanism Mounting Plate	1
RM-3520	Speed Reducer (4 RM-3162-1 & 4 RM-3293-1)	1
RM-3162-1	1/4-20 x 5/8 H.H.S.	14
RM-3293-1	1/4 F.W.	31
RM-2568	Bearing Support (2 RM-3162-1 & 2 RM-3293-1)	1
RM-3407-1	Flange Bearing (2 RM-3162-2 & 2 RM-3293-1)	1
RM-3162-2	1/4-20 x 3/4 H.H.S.	5
RM-3536-1	Flexible Coupling 1/2 x 3/8	1
RM-3413	Shaft Key	1
RM-3522	Transmission (Zero-Max Drive) (4 RM-3162-6 & 4 RM-3293-1)	1
RM-3162-6	1/4-20 x 1/2 H.H.S.	4
RM-2520	Input Shaft	1
22650CD-4	1/4-20 x 1/4 S.S.S.	1
RM-2838D	6" Dia. Pulley	1
RM-2565	Reversing Cylinder Mounting Pivot (1 RM-3293-1 & 1 RM-3162-1)	1
RM-3535	Double Acting Cylinder	1
660-401	Male Elbow	2
RM-2997D	Polyflo Tube 56" Long (N.O. Forward)	1
RM-2997D	Polyflo Tube 54" Long (N.C. Reversed)	1
RM-3144-1	"E" Ring 1/4	1
RM-3211-1	1/4-28 H.J.N.	1
RM-2558	Reversing Clevis	1
RM-2559	Reversing Lever	1
RM-2815-1	No. 6-32 x 1/2 S.H.S.	1
RM-2994C	1/4 x 3/4 Clevis Pin	1
660-142	1/16 x 1/2 Cotter Pin	1

ELECTRIC CLUTCH & TRANSMISSION ASSEMBLY
(continued)

PART NO	DESCRIPTION	AMT REQ
RM-3330	Gear Box Support Spacer (7 RM-3162-1, 3 RM-3162-2 & 10 RM-3193-1)	5
RM-2847D	Electric Clutch	1
RM-3259D	Shaft Key	1
RM-2507	Drive Shaft	1
RM-3329	Pulley Support (4 RM-3162-5, 4 RM-3293-1, 4 RM-2791-3 & 4 652C-16)	1
RM-3601	Clutch Cable Assembly	1
RM-3414-1	No. 8-32 x 1 R.H.S.	1
RM-2747-6	No. 8 L.W.	1
RM-2791-1	No. 8-32 H.N.	1
RM-2553D	Stop Support Spacer	1
RM-2554D	Adjustable Stop Support Rear	1
RM-2555D	Adjustable Stop Support Front (2 RM-3162-4 & 2 652C-16)	1
RM-3162-4	1/4-20 x 3-1/2 H.H.S.	2
652C-16	1/4 F.W.	8
RM-3545	Adjustable Stop & Switch Block	1
RM-3544	Switch Mounting Bracket (2 RM-3289-5 & 2 RM-3293-6)	1
RM-3293-6	No. 10 F.W.	6
RM-3127D	Leaf Switch (2 RM-2805-2 & 2 53678N)	1
RM-3602	Return Motor & Switch Cable Assembly	1
RM-3855D	Switch Enclosure	1
RM-2805-2	No. 6-32 x 1 B.H.S.	2
53678N	No. 6 F.W.	2
RM-2557D	Stop Adjustment Rod	1
RM-2954B	Snap Ring	1
RM-3846D	Threaded Shaft Knob	1
RM-3211-1	1/4-28 H.J.N.	1
RM-3289-5	No. 10-32 x 3/8 B.H.S.	2
RM-2522	Return Motor Mounting Bracket (2 22652D-8 & 2 RM-3293-1)	1
22652D-8	1/4-20 x 1/2 S.H.S.	2
RM-3521	Carriage Return Motor (4 RM-3293-6 & 4 651H)	1
651H	No. 10-32 H.N.	4
RM-3542-1	Timing Belt Pulley	2
RM-3557-1	Timing Belt 3/8 x 15	1
RM-2998-1	Thrust Bearing 5/8	1
RM-3239-2	Thrust Washer 5/8	2
RM-3562	Drive Pulley	1
22650CD-6	1/4-20 x 3/8 S.S.S.	2
RM-3257D	Screw Pin Bumper	1
RM-3162-5	1/4-20 x 2-1/4 H.H.S.	6
RM-2791-3	1/4-20 H.N.	6
RM-2473	Support Spacer Plate (2 RM-3162-5, 2 RM-2791-3, 2 652C-16 & 2 RM-3293-1)	1
21262H-450	"V" Belt 1/2 x 45	1

BOBBIN MOTOR ASSEMBLY

PART NO	DESCRIPTION	AMT REQ
RM-3404	Bobbin Motor Mounting Studs	2
RM-3417	Bobbin Motor Assembly	1
RM-3603	Bobbin Motor Cable Assembly	1
RM-2813-3	No. 8-32 x 3/8 B.H.S.	3
RM-3293-5	No. 8 F.W.	3
RM-2747-6	No. 8 L.W.	2
99578B	Bracket (from 29480 GU)	1
SC 472	Screw (from 29480 GU)	2
998-264	Pushbutton Switch	1
RM-3604	Bobbin Switch Cable Assembly	1
61377J	Pulley Shaft	1
RM-3419-1	Shaft Coupling 1/4	1
RM-3285-3	Snap Bushing	1
61477C	Tension Bracket (1 RM-2813-3 & 1 RM-3293-3)	1
109	Tension Disc	2
61392F-14	Tension Spring	1
61292C	Tension Nut	1
RM-3416	Tension Assembly Bracket	1
RM-2787-1	No. 12 x 1 D.H.S.M.S.	1
RM-3293-1	1/4 F.W.	1
	1-660-356 Cable Clamp & 1 SC 333A from 29480 GU	

SEWING HEAD ASSEMBLY

PART NO	DESCRIPTION	AMT REQ
RM-3091D	Oil Drip Pan Modification (1 SC 331 & 1 22846Q-16)	1
63476	Isolator Pad, Left	2
63476A	Isolator Clip, Left	2
63476B	Isolator Pad, Right	2
63476C	Isolator Clip, Right	2
RM-3238D	Bed Positioning Spring Mod.	1
RM-3121D	Machine Positioner	1
RM-2813-3	No. 8-32 x 3/8 B.H.S.	1
SC331	Wood Screw, Round Head	1
22846Q-16	Wood Screw, Countersunk Head	1
RM-3097D	Retaining Plate Modification	1
21393S	Bolt	2
651-16	Nut	2
666-166	Oil Drain Jar, Glass	1
21393L	Oil Drain Jar Clamp Spring	1
4-63400 KBZ	Basic Sewing Machine Bi-Directional Seamer	1
RM-3356	Sewing Machine Modification	1

SEWING HEAD ASSEMBLY (continued)

PART NO	DESCRIPTION	AMT REQ
RM-2783D	Oil Pan Shim (Quantity as Required) Glue RM-2783D w/3M No. 826	
63468B	Lifter Lever Extension Stud	1
652B-20	Lock Washer	1
660-397	Cylinder	1
660-401	Male Elbow	1
RM-2997D	Polyflo Tube 34" Long	1
660-245	Retaining Ring	1
RM-3211-2	5/16-24 H.J.N.	1
RM-3347	Cylinder Clevis	1
63468C	Link	1
53634C	Flat Washer	2
660-142	Cotter Pin	2
RM-2997D	Polyflo Tube 42" Long	1
RM-3350	Clamp Block	1
22585A	Screw	1
RM-2385D	Throat Plate	1
RM-3494	Screw	2
61378	Rest Pin	1
RM-3127D	Leaf Switch (2 RM-2805-1, 2 53678N & 2 RM-2747-2)	1
RM-3607	Clamp Interlock Switch Cable Assembly	1
RM-2855D	Switch Enclosure	1
RM-3357	Switch Spacer	2
RM-2805-1	No. 6-32 x 1-1/4 B.H.S.	2
RM-2747-2	No. 6 L.W.	2
53678N	No. 6 F.W.	2
21261M-410	3/8 x 41 "V" Belt	1

PHOTOCELL ASSEMBLY

PART NO	DESCRIPTION	AMT REQ
RM-3432	Fly Seamer Photocell	1
RM-3605	Photocell Cable Assembly	1
RM-3403	Photocell Bracket	1
RM-3289-3	No. 10-32 x 1-1/2 B.H.S.	1
RM-3293-6	No. 10 F.W.	1
RM-3461	Photocell Clamp	1
RM-3462-1	No. 5-40 x 3/16 F.H.S.	1

CARRIAGE ASSEMBLY

PART NO	DESCRIPTION	AMT REQ
RM-2547D	Lower Cam Plate Block	2
RM-2548D	Washer Plate	2
RM-3162-5	1/4-20 x 2-1/4 H.H.S.	6
RM-3293-1	1/4 F.W.	6

CARRIAGE ASSEMBLY (continued)

PART NO	DESCRIPTION	AMT REQ
652C-16	1/4 L.W.	6
RM-3425	Carriage Bottom Plate (4 RM-2798-1, 5 RM-2879-2 & 5 RM-3523-1)	1
RM-2873D	Mounting Bracket	1
94	0.182-40 x 1/4 Fil.H.S.	2
RM-2747-4	No. 10 L.W.	2
RM-2874D	Single Acting Cylinder	1
660-401	Male Elbow	1
RM-3674	Lift Wedge Clevis	1
RM-3675	Lift Wedge Pivot Screw	1
RM-3676	Lift Wedge	1
RM-3211-1	1/4-28 H.J.N.	1
RM-2950B	PVC Tubing 53" Long	1
RM-3423	Clamp Plate Support (5 RM-2879-2 & 5 RM-3523-1)	1
RM-3437-1	Dowel Pin .251 x 1-1/4	1
478-12	Bearing	2
RM-3424	Lift Rod Support	2
22596D	0.182-40 x 3/8 Fil.H.S.	4
RM-2607D	Clamp Plate Support Hinge	1
RM-2879-2	Pop Rivet	10
RM-3523-1	Burr Washer No. 10	10
RM-2524D	Right Carriage Block (6 RM-2798-1)	2
RM-2534D	Left Carriage Block (6 RM-2798-1)	2
RM-3124D	1/4 Ball Bushing	4
RM-3128D	1/4 Ball Bushing Retaining Ring	8
RM-2798-1	No. 8-32 x 1/2 F.H.S.S.	4
RM-3122D	1/4 Dia. Shaft	2
RM-2528D	Front Linear Carriage Block (4 RM-2813-2 & 4 RM-2747-6)	2
RM-2529D	Rear Linear Carriage Block (4 RM-2813-2 & 4 RM-2747-6)	2
RM-3126D	1/2 Ball Bushing	4
RM-3129D	1/2 Ball Bushing Retaining Ring	8
RM-2626D	Main Carriage Plate	1
RM-2813-2	No. 8-32 x 5/16 B.H.S.	8
RM-2747-6	No. 8 L.W.	8
RM-2512D	Carriage Top Plate (8 RM-2798-1)	1
RM-2539D	Cable Pivot Stud	1
RM-2747-3	3/8 L.W.	1
80576	3/8-16 H.N.	1
RM-2798-1	No. 8-32 x 1/2 F.H.S.S.	8
RM-3123D	1/2 Dia. Shaft	2
RM-2508D	Right Hand Cam Plate Block (2 RM-3162-9 & 2 RM-3293-1)	1
RM-2784D	Left Hand Cam Plate Block (2 RM-3162-9 & 2 RM-3293-1)	1
RM-3162-9	1/4-20 x 2-1/2 H.H.S.	4
RM-3293-1	1/4 F.W.	4

CLAMP PLATE ASSEMBLY

PART NO	DESCRIPTION	AMT REQ
RM-2606D	Clamp Plate (6 RM-3046D & 4 RM-2808-1)	1
RM-3015D	Spring Clip	4
RM-3034D	Clip Mounting Spacer	4
87U	0.124-50 x 3/16 Fil.H.S.	8
RM-2808-1	No. 6-32 x 1/4 S.S.S.	4
RM-2618D	Vision Flap Pivot	1
RM-3492-1	No. 6-32 x 1/4 F.H.S.	2
RM-2608D	Vision Flap	1
RM-2615D	Vision Flap Guide	2
22561	0.124-50 x 9/64 Fil.H.S.	4
RM-2974B	Cylinder 01-1/2 (1-651-H)	1
RM-2965	Hose Fitting w/Gasket	1
RM-2950B	PVC Tubing 58-1/2" Long	1
RM-2612D	Cylinder Mounting Plate (2 22585A)	1
651-H	No. 10-32 H.N.	1
RM-2531D	Vision Plate Clevis	1
RM-3054B	3/16 x 19/32 Clevis Pin	1
660-142	1/16 x 1/2 Cotter Pin	1
22585A	0.146-40 x 5/16 Fil.H.S.	2
RM-2980B	1/8 Tubing 71" Long	1
RM-3305-2	1/8 Cable Clamp (1 RM-2736A)	1
RM-2736A	No. 6-32 x 1/4 B.H.S.	6
RM-3377	Outer Curved Rubber Strip Assembly (2 RM-3187-1)	1
RM-3187-1	No. 6-32 x 3/16 R.H.S.	5
RM-3333	Outer Rubber Strip Assembly (3 RM-3187-1)	1
RM-3436	Vision Flap Rubber Strip Assembly (2 RM-2736A)	1
RM-3446	Inner Rubber Strip Assembly (3 RM-2736A)	1
RM-3080D	Garment Stop	1
2277A	Shoulder Screw	1
RM-3081D	Garment Stop Bracket	1
RM-3289-5	No. 10-32 x 3/8 B.H.S.	1
RM-3293-6	No. 10 F.W.	1
RM-3046D	No. 10-32 x 5/16 H.H. Sems	6
RM-2871B	Cable Tie	2

CAM PLATE ASSEMBLY

PART NO	DESCRIPTION	AMT REQ
RM-3561	Cam Plate (4 RM-3068D, 4 22652D-12 & 4 652C-16)	1
RM-2650D	Top Cover Support (1 RM-3068D & 1 22652D-8)	1
RM-3068D	Washer	5
22652D-8	1/4-20 x 1/2 S.H.S.	1
22799T	Screw Pin	1
RM-2514D	Cam Pulley (1 RM-3438-1, 5 RM-3293-2 & 1 22617J-24)	1

CAM PLATE ASSEMBLY (continued)

PART NO	DESCRIPTION	AMT REQ
RM-3650	Cam Pulley Screw Pin	1
RM-3258D	Bumper for Screw Pin	1
RM-3438-1	5/16-18 x 1-1/2 H.H.S.	3
RM-3293-2	5/16 F.W.	6
RM-2693D	Cam Pulley Return Spring	1
22617J-24	No. 6-32 x 3/8 Fil.H.S.	1
RM-2518D	Tracking Pulley	4
RM-2682D	Idler Pulley Stud (1 RM-3438-1)	1
RM-2519	Tension Pulley Bracket	1
RM-3162-1	1/4-20 x 5/8 H.H.S.	2
RM-3293-1	1/4 F.W.	2
RM-2474-1	Pulley Mounting Spacer	1
RM-3483-4	5/16-18 x 1-1/4 H.H.S.	1
RM-2474-2	Pulley Mounting Spacer (1 RM-3438-1 & 1 RM-3293-2)	1
RM-3608	Return Wire Rope Assembly	1
RM-2596D	Left Hand Wire Rope Assembly	1
RM-2541D	Cam Roller	1
RM-2540D	Cable Pivot (1 22651CB-4)	2
22651CB-4	No. 10-32 x 1/4 S.S.S.	2
RM-3289-5	No. 10-32 x 3/8 B.H.S.	1
RM-3293-6	No. 10 F.W.	1
22652D-2	1/4-20 x 3/4 S.H.S.	4
652C16	1/4 L.W.	4

SAFETY SWITCH ASSEMBLY

PART NO	DESCRIPTION	AMT REQ
RM-3127D	Leaf Switch (2 RM-3611-1, 4 RM-3293-1 & 2 53678N)	2
RM-2855D	Switch Enclosure	2
RM-3681-1	No. 6 x 2-1/2 R.H.W.S.	2
RM-3293-1	1/4 F.W.	4
53678N	No. 6 F.W.	2
RM-3609	Safety Switch Cable Assembly, 3 Conductor	1
RM-3610	Safety Switch Cable Assembly, 2 Conductor	1
RM-3711	Carriage Tube Guide	1

CONTROL BOX ASSEMBLY

PART NO	DESCRIPTION	AMT REQ
RM-3612	Step Down Transformer	1
RM-3289-1	No. 10-32 x 2 B.H.S.	2
RM-3293-6	No. 10 F.W.	4
RM-2747-4	No. 10 L.W.	1
651-H	No. 10-32 H.N.	2

CONTROL BOX ASSEMBLY (continued)

PART NO	DESCRIPTION	AMT REQ
RM-3613	Terminal Block	1
RM-3154D	No. 6 x 1-1/2 R.H.W.S.	2
RM-3614	Switch Box to Control Box Cable Assembly	1
RM-3573	Control Box Mounting Post (4 RM-3162-7 & 4 RM-3293-1)	4
RM-3162-7	1/4-20 x 2 H.H.S.	4
RM-3293-1	1/4 F.W.	8
RM-3577	Control Box Base (4 RM-3162-6 & 4 RM-3293-1)	1
RM-3162-6	1/4-20 x 1/2 H.H.S.	4
RM-3623-1	Spacer (5 RM-2736A & 5 53678N)	5
RM-2736A	No. 6-32 x 1/4 B.H.S.	10
53678N	No. 6 F.W.	5
RM-2737A	Fuse Holder	3
RM-3048-3	Fuse .3 Amp (Upper & Middle)	2
RM-3048-4	Fuse 3.0 Amp (Lower)	1
RM-3635	Control Panel	1
RM-3627	Switch 2PDT (Backtack)	1
RM-2748A	Switch SPST (Clamp)	1
RM-3376	Switch DPST (Main)	1
RM-3088-8	Pot 500 K (Backtack)	1
RM-3088-7	Pot 50 K (Stop Position)	1
RM-3653	Potentiometer Bracket	1
RM-3088-3	Pot 100 K (Stop Position Piggy Back)	1
RM-3088-4	Pot 350 K (Bobbin Winder)	1
RM-3435	Nut	4
RM-2749A	Pilot Lite	1
RM-3443	Knob	3
RM-3146D	Rubber Grommet	2
RM-3624	Backtack Cable Harness	1
RM-3618	Backtack Motor Board (5 RM-2736A)	1
RM-3281-1	Strain Relief Bushing	2
RM-2740A	Strain Relief Bushing	3
RM-3281-2	Strain Relief Bushing	5
RM-2813-4	No. 8-32 x 1/2 B.H.S.	1
RM-2747-6	No. 8 L.W.	8
RM-2791-1	No. 8-32 H.N.	7
RM-3628	Pneumatic Component Assembly (6 RM-2813-1, 6 RM-2747-6 & 6 RM-2791-1)	1
RM-2813-1	No. 8-32 x 1/4 B.H.S.	6
RM-3625-1	Terminal Strip	1
RM-3626-1	Terminal Strip Jumper	1
RM-2733A	No. 6-32 x 1/2 B.H.S.	2
RM-2747-2	No. 6 L.W.	2
RM-2791-2	No. 6-32 H.N.	2
RM-2997D	Polyflo Tube 41" Long (Wiper)	1
RM-2997D	Polyflo Tube 38" Long (Supply)	1

CONTROL BOX ASSEMBLY (continued)

PART NO	DESCRIPTION	AMT REQ
RM-3574	Control Box Rear Ground (2 RM-3289-7)	1
RM-3289-7	No. 10-32 x 1/4 B.H.S.	4
RM-3575	Control Box Side Shroud (1 RM-3289-7)	2
RM-3619	Backtack Control Board	1
RM-3620	Backtack Power Board	1
RM-3579	Control Box Cover	1
RM-3289-5	No. 10-32 x 3/8 B.H.S.	4
RM-2871B	Cable Tie	19

TREADLE ASSEMBLY

PART NO	DESCRIPTION	AMT REQ
RM-3611	Start Switch Assembly (2 RM-2813-3, 2 RM-2813-7 or 2 RM-3306-2)	1
RM-2813-3	No. 8-32 x 3/8 B.H.S.	2
RM-2813-7	No. 8-32 x 3/16 B.H.S.	2
RM-3450	Switch Plate (2 RM-2813-3)	1
RM-3460	1-3/8 "U" Bolt w/Nuts	1
RM-3525	Start Switch Treadle Plate (2 RM-2813-7)	1

ACCESSORIES

PART NO	DESCRIPTION	AMT REQ
RM-3451	Actuator Rod	1
RM-3452	Rod Sleeve	1
RM-3453	Rod Support (3 RM-3306-2)	1
RM-3306-2	No. 10-32 x 5/8 S.H.S.	3
RM-3449	Switch Plate Leg Extension (2 RM-3162-6, 2 RM-3293-1, RM-2827-9, 652L-24 & RM-3211-3)	1
RM-3162-6	1/4-20 x 1/2 H.H.S.	2
RM-3293-1	1/4 F.W.	2
RM-3454	Leg Extension (RM-2827-9, 652L-24 & RM-3211-3)	7
51-214 BLK	Spacer	8
RM-2827-9	3/8-16 x 3 H.H.S.	16
652L-24	Washer	16
RM-3211-3	3/8-16 H.N.	8
RM-3647	Kit	1

CONTROL BOX ASSEMBLY (continued)

PART NO	DESCRIPTION	AMT REQ
RM-3613	Terminal Block	1
RM-3154D	No. 6 x 1-1/2 R.H.W.S.	2
RM-3614	Switch Box to Control Box Cable Assembly	1
RM-3573	Control Box Mounting Post (4 RM-3162-7 & 4 RM-3293-1)	4
RM-3162-7	1/4-20 x 2 H.H.S.	4
RM-3293-1	1/4 F.W.	8
RM-3577	Control Box Base (4 RM-3162-6 & 4 RM-3293-1)	1
RM-3162-6	1/4-20 x 1/2 H.H.S.	4
RM-3623-1	Spacer (5 RM-2736A & 5 53678N)	5
RM-2736A	No. 6-32 x 1/4 B.H.S.	10
53678N	No. 6 F.W.	5
RM-2737A	Fuse Holder	3
RM-3048-3	Fuse .3 Amp (Upper & Middle)	2
RM-3048-4	Fuse 3.0 Amp (Lower)	1
RM-3635	Control Panel	1
RM-3627	Switch 2PDT (Backtack)	1
RM-2748A	Switch SPST (Clamp)	1
RM-3376	Switch DPST (Main)	1
RM-3088-8	Pot 500 K (Backtack)	1
RM-3088-7	Pot 50 K (Stop Position)	1
RM-3653	Potentiometer Bracket	1
RM-3088-3	Pot 100 K (Stop Position Piggy Back)	1
RM-3088-4	Pot 350 K (Bobbin Winder)	1
RM-3435	Nut	4
RM-2749A	Pilot Lite	1
RM-3443	Knob	3
RM-3146D	Rubber Grommet	2
RM-3624	Backtack Cable Harness	1
RM-3618	Backtack Motor Board (5 RM-2736A)	1
RM-3281-1	Strain Relief Bushing	2
RM-2740A	Strain Relief Bushing	3
RM-3281-2	Strain Relief Bushing	5
RM-2813-4	No. 8-32 x 1/2 B.H.S.	1
RM-2747-6	No. 8 L.W.	8
RM-2791-1	No. 8-32 H.N.	7
RM-3628	Pneumatic Component Assembly (6 RM-2813-1, 6 RM-2747-6 & 6 RM-2791-1)	1
RM-2813-1	No. 8-32 x 1/4 B.H.S.	6
RM-3625-1	Terminal Strip	1
RM-3626-1	Terminal Strip Jumper	1
RM-2733A	No. 6-32 x 1/2 B.H.S.	2
RM-2747-2	No. 6 L.W.	2
RM-2791-2	No. 6-32 H.N.	2
RM-2997D	Polyflo Tube 41" Long (Wiper)	1
RM-2997D	Polyflo Tube 38" Long (Supply)	1

CONTROL BOX ASSEMBLY (continued)

PART NO	DESCRIPTION	AMT REQ
RM-3574	Control Box Rear Shroud (2 RM-3289-7)	1
RM-3289-7	No. 10-32 x 1/4 B.H.S.	4
RM-3575	Control Box Side Shroud (1 RM-3289-7)	2
RM-3619	Backtack Control Board	1
RM-3620	Backtack Power Board	1
RM-3579	Control Box Cover	1
RM-3289-5	No. 10-32 x 3/8 B.H.S.	4
RM-2871B	Cable Tie	19

TREADLE ASSEMBLY

PART NO	DESCRIPTION	AMT REQ
RM-3611	Start Switch Assembly (2 RM-2813-3, 2 RM-2813-7 or 2 RM-3306-2)	1
RM-2813-3	No. 8-32 x 3/8 B.H.S.	2
RM-2813-7	No. 8-32 x 3/16 B.H.S.	2
RM-3450	Switch Plate (2 RM-2813-3)	1
RM-3460	1-3/8 "U" Bolt w/Nuts	1
RM-3525	Start Switch Treadle Plate (2 RM-2813-7)	1

ACCESSORIES

PART NO	DESCRIPTION	AMT REQ
RM-3451	Actuator Rod	1
RM-3452	Rod Sleeve	1
RM-3453	Rod Support (3 RM-3306-2)	1
RM-3306-2	No. 10-32 x 5/8 S.H.S.	3
RM-3449	Switch Plate Leg Extension (2 RM-3162-6, 2 RM-3293-1, RM-2827-9, 652L-24 & RM-3211-3)	1
RM-3162-6	1/4-20 x 1/2 H.H.S.	2
RM-3293-1	1/4 F.W.	2
RM-3454	Leg Extension (RM-2827-9, 652L-24 & RM-3211-3)	7
51-214 BLK	Spacer	8
RM-2827-9	3/8-16 x 3 H.H.S.	16
652L-24	Washer	16
RM-3211-3	3/8-16 H.N.	8
RM-3647	Kit	1

CLAMP PLATE AIR TUBE ASSEMBLY

PART NO	DESCRIPTION	AMT REQ
RM-2715D	Air Tube Guide (1 RM-3162-5 & 1 RM-3293-1)	1
RM-3263D	Bulk Head Union	2
RM-2997D	Polyflo Tube 16" Long (Vision)	1
RM-2997D	Polyflo Tube 14-1/2" Long (Clamp)	1
RM-3464	1/16 Hose Fitting	1
RM-3465-1	Pipe to Female 10-32 Adapt.	1
RM-3266-1	Female Connector	1
RM-2997D	Polyflo Tube 15" Long (Wiper)	1
RM-3484	Tygon Tubing 42" Long	1
RM-3305-3	Cable Clamp	1
RM-2719-1	No. 10 x 1 S.M.S.	1
RM-3293-6	No. 10 F.W.	1

REGULATOR ASSEMBLY

PART NO	DESCRIPTION	AMT REQ
660-398	Regulator (Mounting Bracket Not Required)	1
RM-3160A	Run Tee 1/4	1
RM-3287-1	Hex Nipple 1/4	1
660-401	Male Elbow	1
RM-3312-1	Filter	1
RM-3362-1	Male Elbow	1
RM-3315	Regulator Mounting Stud	1
RM-3293-3	3/8 F.W.	1
RM-2827-4	3/8-16 x 1/2 H.H.S.	1

SWITCH BOX ASSEMBLY

PART NO	DESCRIPTION	AMT REQ
CO44H	1-D776493-02, 1 CO44H & 2 SC333A from 29480 GU Box Connector (Include 1 CO44H in Accessory Box BO-172)	2
RM-2813-5	No. 8-32 x 5/8 B.H.S.	1
RM-2747-6	No. 8 L.W.	3
RM-2791-1	No. 8-32 H.N.	1
TA 85	Tag	1

TABLE TOP ASSEMBLY

PART NO	DESCRIPTION	AMT REQ
RM-3402	Stainless Table	1
RM-3289-1	No. 10-32 x 2 B.H.S.	2
RM-3621-1	Tee Nuts 10-32	2

Note: Drill 15/64 Dia. 2 Holes for RM-3621-1 after RM-3402 is Positioned.

COVERS

PART NO	DESCRIPTION	AMT REQ
RM-3616	Left Cover	1
RM-3343	Right Cover	1
660-112	Cabinet Catch	4
RM-2813-1	No. 8-32 x 1/4 B.H.S.	8
RM-2791-1	No. 8-32 H.N.	8
RM-3444-1	Wing Screw	1
RM-2747-6	No. 8 L.N.	8

THREAD STAND ASSEMBLY

PART NO	DESCRIPTION	AMT REQ
RM-3617	Single Spool Thread Stand	2
SC-305	Wood Screw	4

BELT GUARD

PART NO	DESCRIPTION	AMT REQ
RM-3645	Backtack Belt Guard	1
RM-3289-2	No. 10-32 x 5/8 B.H.S.	4

LITE ASSEMBLY

PART NO	DESCRIPTION	AMT REQ
RM-3490	Light Fixture	1

**SECTION VII
SCHEMATICS**

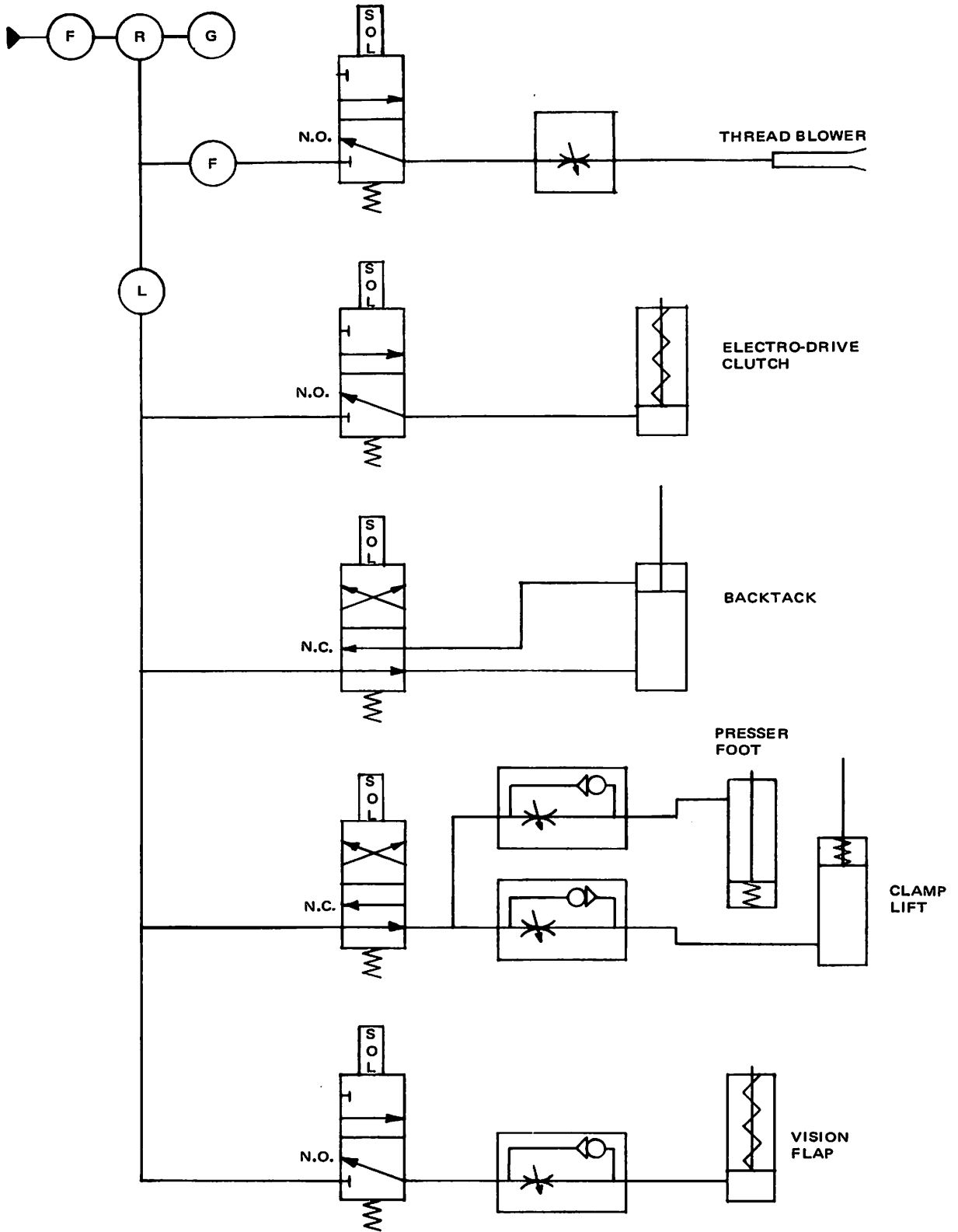

**AIR DIAGRAM SHOWING WHEN MACHINE IS AT REST, AIR LINE
CONNECTED AND MAIN ELECTRICAL SWITCH IS ON**

PULL SWITCH LEVER:
 Mh micro switch auxiliary drive
 Mp micro switch needle position
 Md micro switch presser foot lifting

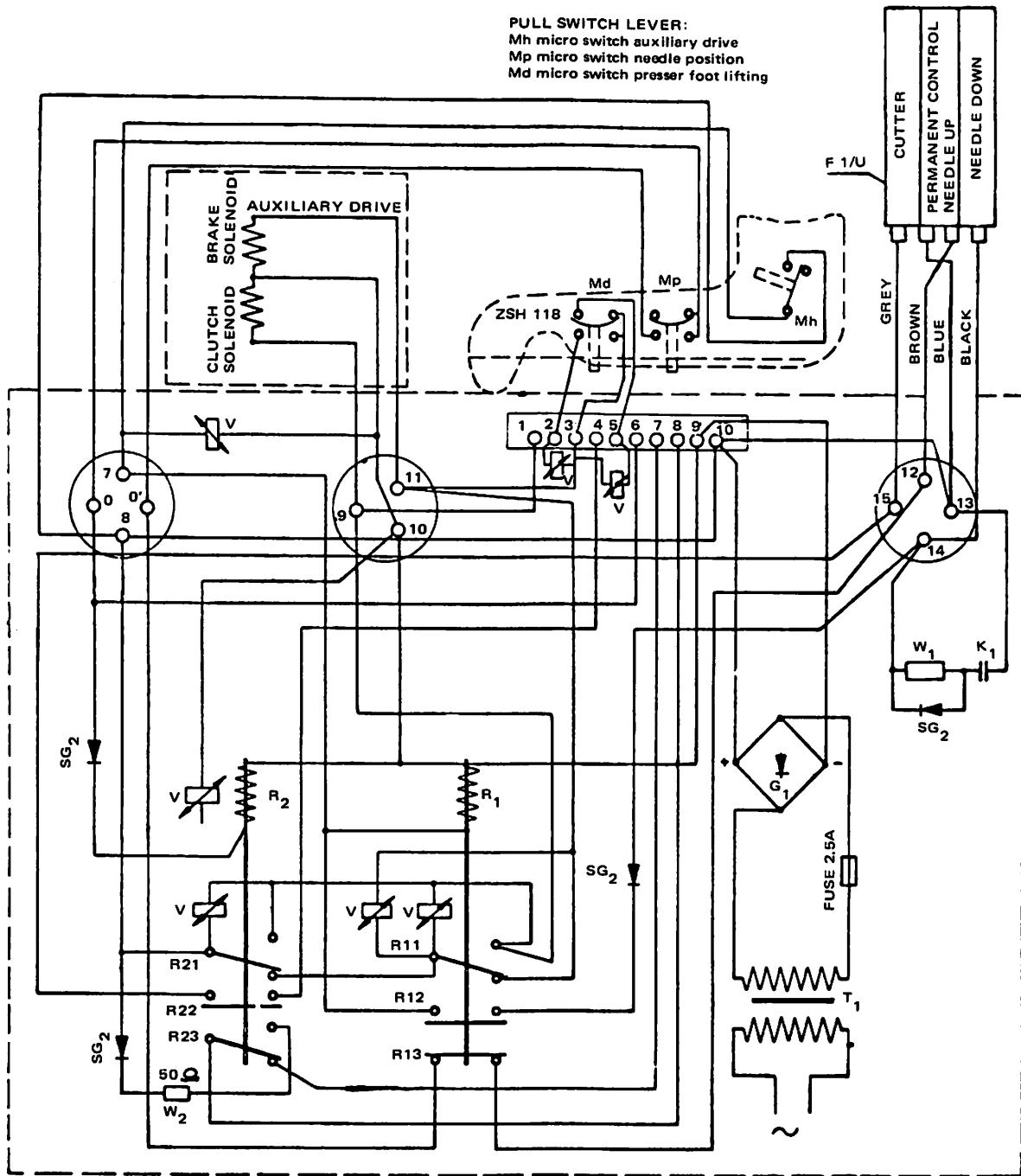

MOTOR CONTROL PANEL (F2 - UNION)

- R1 Relay (1 change over contact, 1 closing contact, 1 opening contact)
- R2 Relay (2 change over contact, 1 closing contact)
- G1 Rectifier 24 V, 1.5A
- T1 Transformer, secondary 30 V, 35 V
- SG2 Diode (BY 103)
- V Varistor
- K1 Capacitor 4.7 + 3.3 Mfd.
- W1 Resistor 2,200 ohm
- W2 Resistor 50 ohm

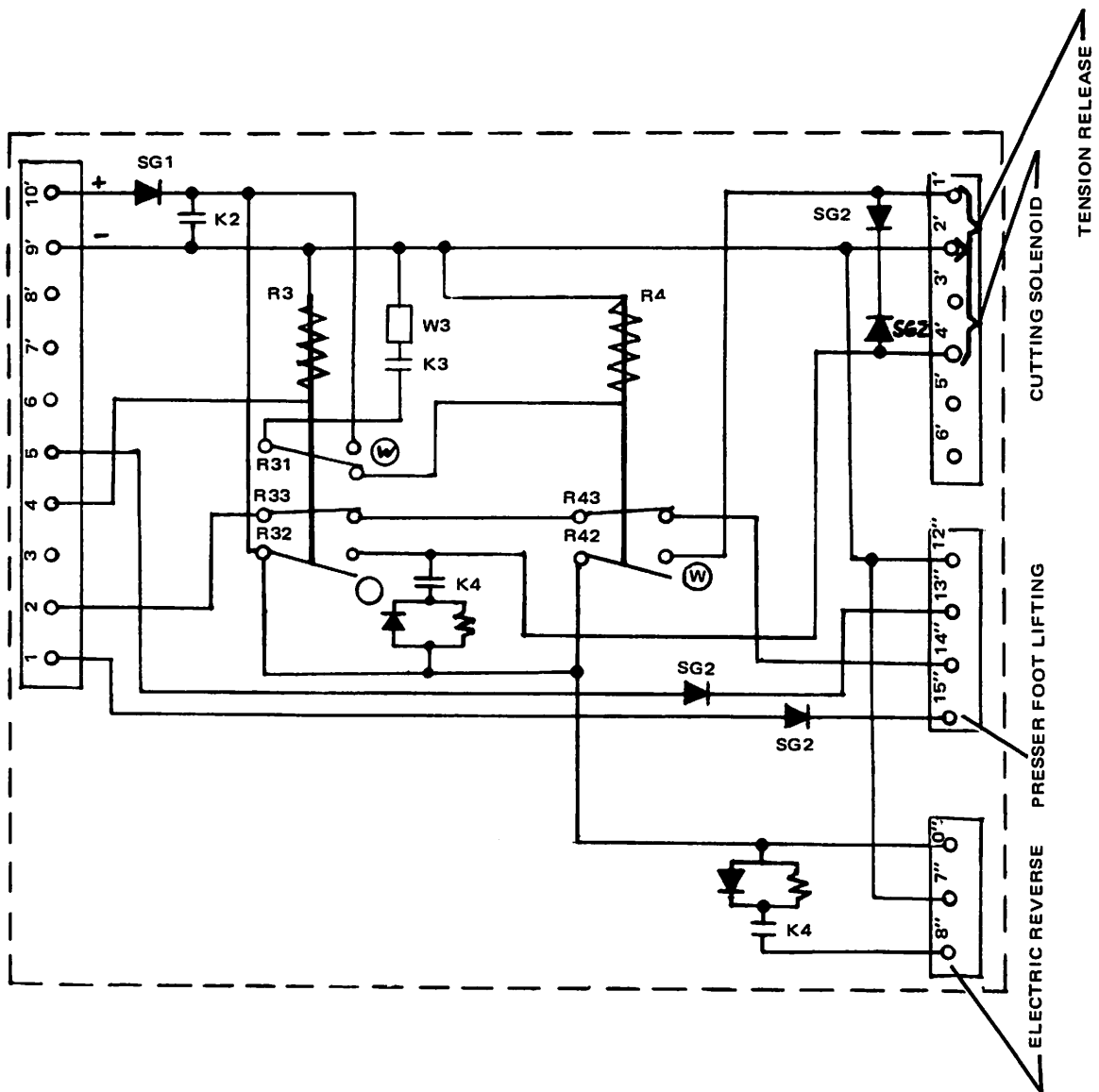

AUXILIARY CONTROL BOX (No. 998-251)

- R3 Relay (1 change over contact, 1 opening contact, 1 closing contact)
- R4 Relay (2 closing contact, 1 opening contact)
- W3 Resistor 20 ohm
- K2 Capacitor 5000 Mfd.
- K3 Capacitor 1000 Mfd.
- K4 Capacitor 20 Mfd.
- SG1 Diode (OY 5062)
- SG2 Diode (BY 103)
- w Tungsten contact

**SECTION VIII
TROUBLESHOOTING**

CONTENTS

Title	Page
ELECTRICAL CIRCUIT TROUBLESHOOTING	45
INDEX OF MALFUNCTIONS	
MALFUNCTION	
1. Pilot Lamp Does Not Light When Main Power and Control Power Switches are on	45
2. Clamp Does Not Go Down When Foot Switch is Actuated to First Step	51
3. Machine Does Not Start When Foot Switch is Actuated to Second Step	62
4. Machine Runs, But Clamp Does Not Move	69
5. Clamp Does Not Feed Immediately at Beginning of Cycle	76
6. Machine Stops Before Reaching Preselected Position on Garment	78
7. Machine Sews Beyond Preselected Position on Garment	80
8. Machine Starts Before Clamp is Completely Down	82
9. Vision Plate Will Not Operate	83
10. Machine Will Not Fast Sew	86
11. Clamp Will Not Return to Home Position	89
12. Clamp Returns Too Slowly	93
13. Machine Sews Only When Foot Switch is Engaged	96
14. Stitch Length Varies	97
15. Bobbin Motor Will Not Operate	100
16. Machine Will Not Back-Tack	104
17. Machine Stops, Then Tacks Forward When Set to Back-Tack	105
MAIN MOTOR TROUBLESHOOTING	108
SEWING HEAD TROUBLESHOOTING	109
TRIMMER TROUBLESHOOTING	109

**SECTION VIII
TROUBLESHOOTING**

CONTENTS

Title	Page
ELECTRICAL CIRCUIT TROUBLESHOOTING	45
INDEX OF MALFUNCTIONS	
MALFUNCTION	
1. Pilot Lamp Does Not Light When Main Power and Control Power Switches are on	45
2. Clamp Does Not Go Down When Foot Switch is Actuated to First Step	51
3. Machine Does Not Start When Foot Switch is Actuated to Second Step	62
4. Machine Runs, But Clamp Does Not Move	69
5. Clamp Does Not Feed Immediately at Beginning of Cycle	76
6. Machine Stops Before Reaching Preselected Position on Garment	78
7. Machine Sews Beyond Preselected Position on Garment	80
8. Machine Stops Before Clamp is Completely Down	82
9. Vision Plate Will Not Operate	83
10. Machine Will Not Fast Sew	86
11. Clamp Will Not Return to Home Position	89
12. Clamp Returns Too Slowly	93
13. Machine Sews Only When Foot Switch is Engaged	96
14. Stitch Length Varies	97
15. Bobbin Motor Will Not Operate	100
16. Machine Will Not Back-Tack	104
17. Machine Stops, Then Tacks Forward When Set to Back-Tack	105
MAIN MOTOR TROUBLESHOOTING	108
SEWING HEAD TROUBLESHOOTING	109
TRIMMER TROUBLESHOOTING	109

ELECTRICAL CIRCUIT TROUBLESHOOTING

1. PILOT LAMP DOES NOT LIGHT WHEN MAIN POWER AND CONTROL POWER SWITCHES ARE ON.

ITEM NO. 1

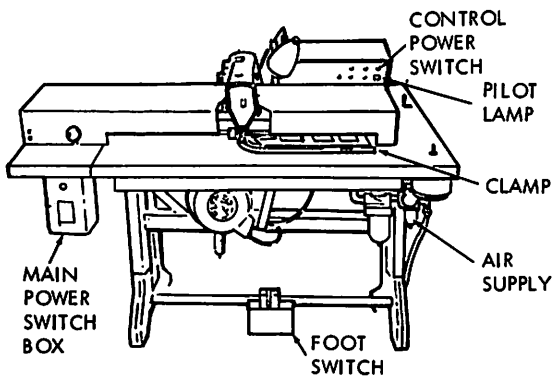
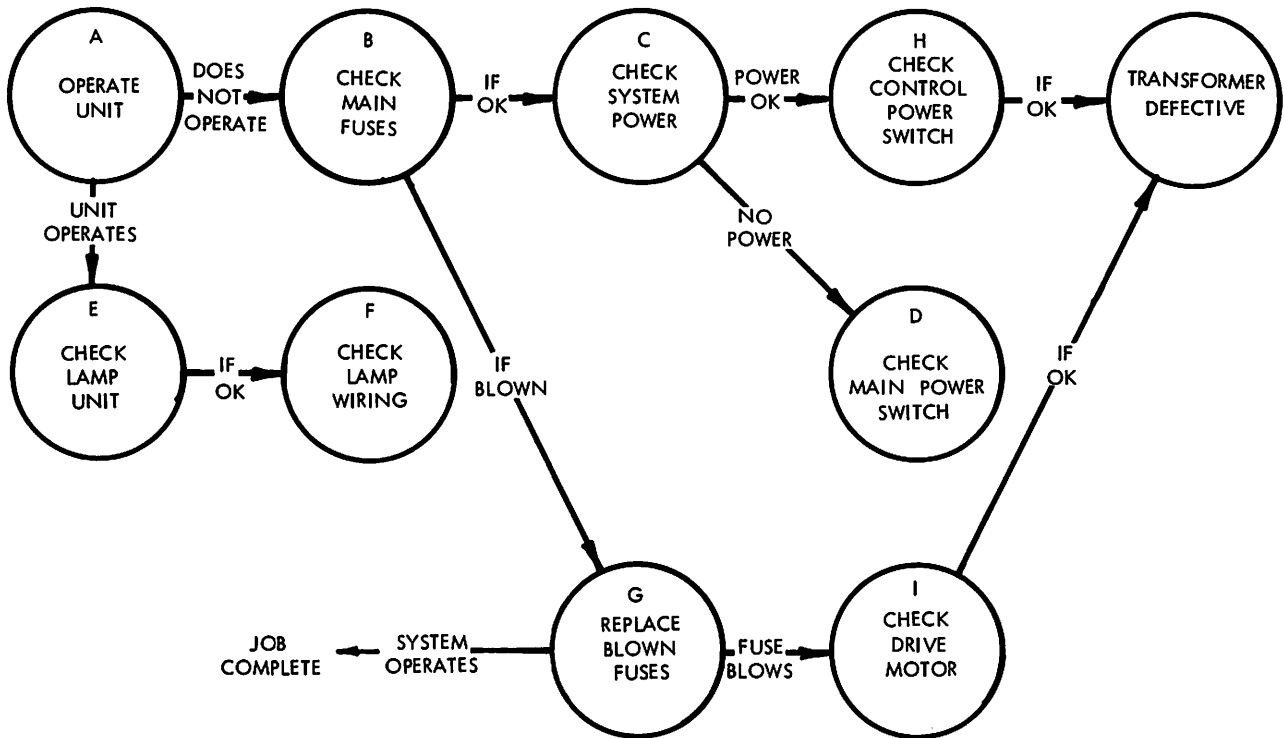

A. OPERATE UNIT:

- (1) Set MAIN POWER switch to ON position.
- (2) Set CONTROL POWER switch to ON position.
- (3) Place a piece of material under clamp and press foot pedal all the way down to second position. Machine should sew. If machine operates, go to paragraph E.

B. CHECK MAIN FUSES:

NOTE

The following procedure is for U.S. units only. Units manufactured for export are equipped with circuit breakers for main power circuit protection.

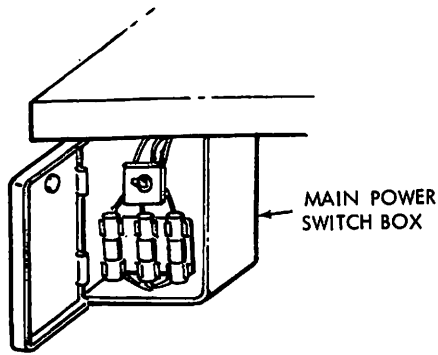

(1) If unit does not operate, turn power off, and open main power switch box.

(2) Disconnect power cable from input power source, and get an ohmmeter.

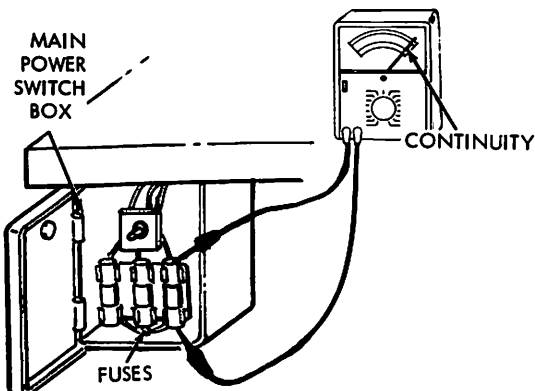
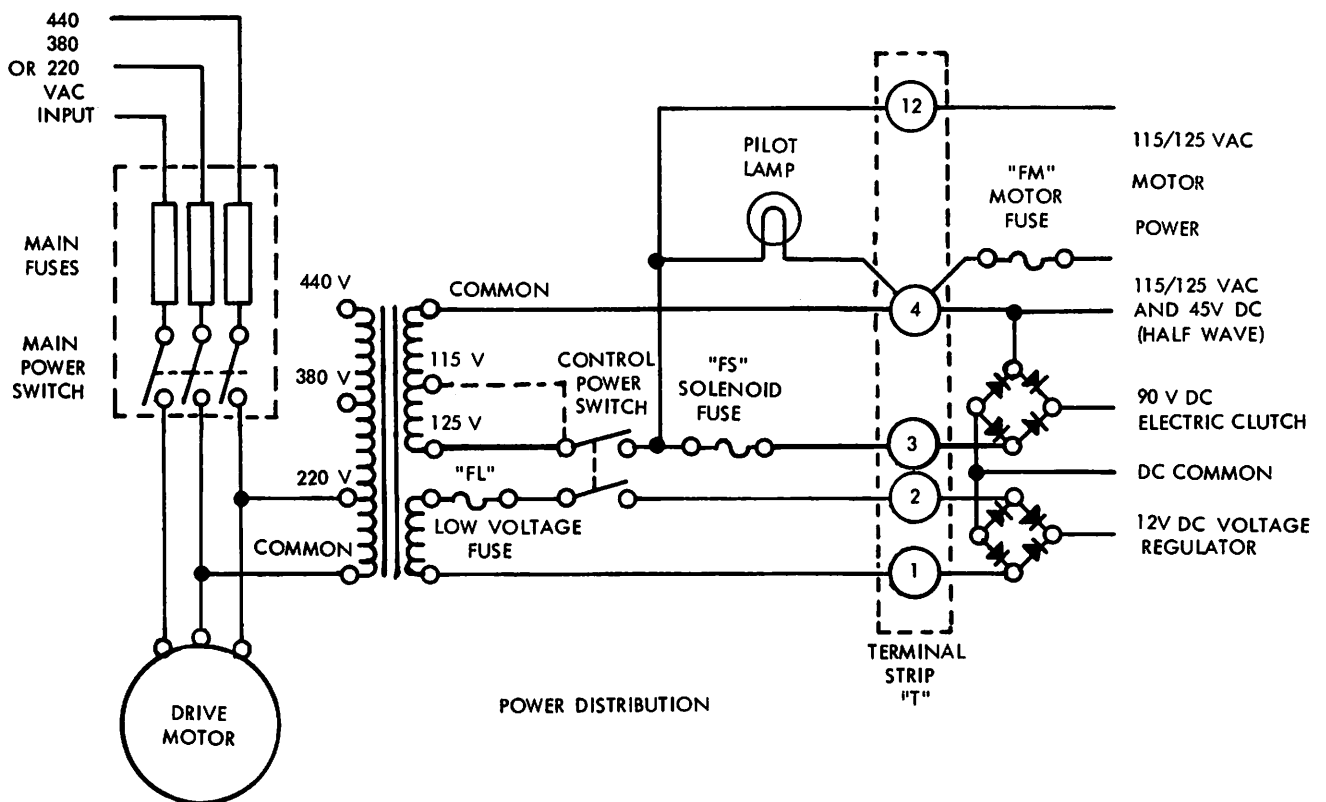

(3) With MAIN POWER switch in OFF position, and main power plug disconnected from power source, check across each fuse with ohmmeter. Fuses should read continuity.

(4) If any fuse reads open, go to paragraph G.

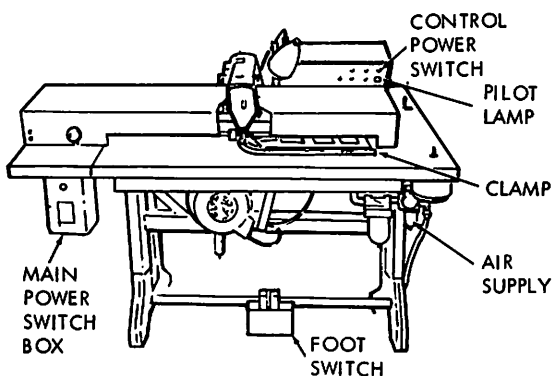

C. CHECK SYSTEM INPUT POWER:

- (1) If main fuses check good, remove rear cover from lower section of control box. Get an AC voltmeter capable of reading at least 440 volts.
- (2) Connect power to system, and set main power and CONTROL POWER switches to ON position.

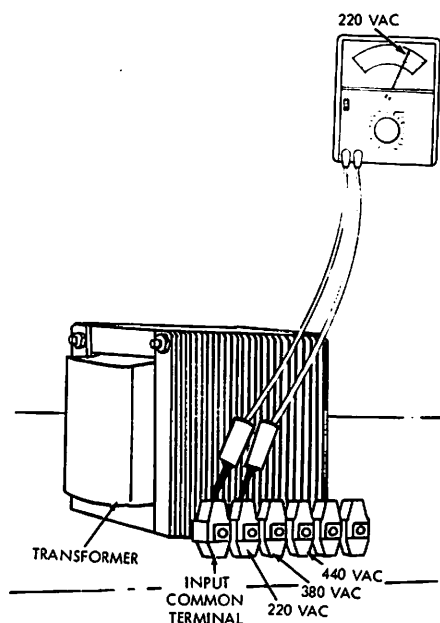

- (3) Use AC voltmeter to measure input power:
 - a. If input leads are connected between first and second terminals of transformer, input voltage should be 220 volts.
 - b. If input leads are connected between first and third terminals, input voltage should be 380 volts.
 - c. If input leads are connected between first and fourth terminals of transformer, input voltage should be 440 volts.
- (4) If system power checks good, go to paragraph H.

D. CHECK MAIN POWER SWITCH:

- (1) If no power is present at control power transformer input, open MAIN POWER switch box.

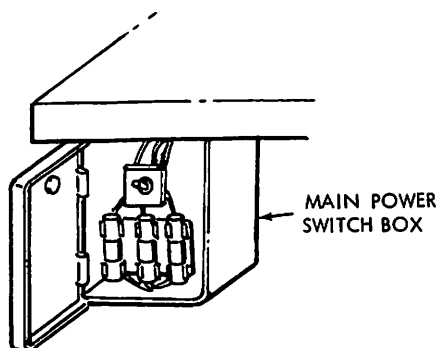

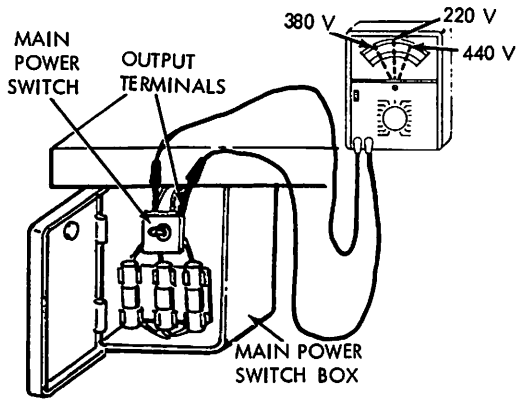

(2) Connect voltmeter leads across switch output leads. Voltmeter should read voltage of input power source. If voltage is correct, go to paragraph H.

(3) If no power is present at MAIN POWER switch output terminals, check for power at input side of switch.

(4) If power is present on input side of MAIN POWER switch, replace switch.

(5) If no power is present at input side of MAIN POWER switch, check service power supply.

E. CHECK LAMP UNIT:

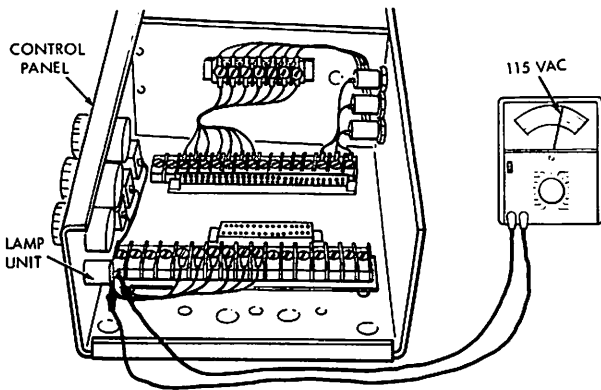

(1) If unit operates properly (paragraph A) set voltmeter to read in 115 volt AC range. Remove top cover from control box.

(2) Connect voltmeter leads across lamp unit terminals with MAIN POWER and CONTROL POWER switches on. Voltmeter should read 115 volts AC.

(3) If voltmeter reads 115 volts AC, replace lamp unit.

F. CHECK LAMP WIRING:

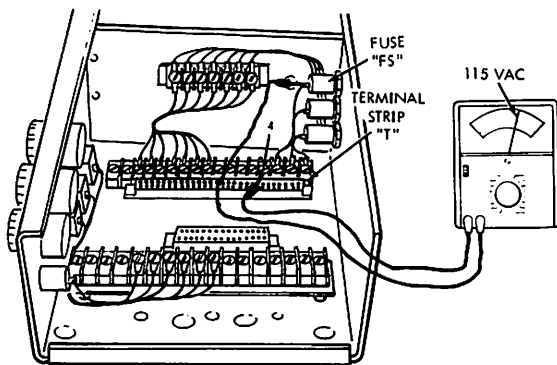

(1) If 115 volts AC is not present at lamp unit terminals, connect voltmeter leads between terminal 4 of terminal strip "T" and input side of fuse "FS". Voltmeter should read 115 volts AC.

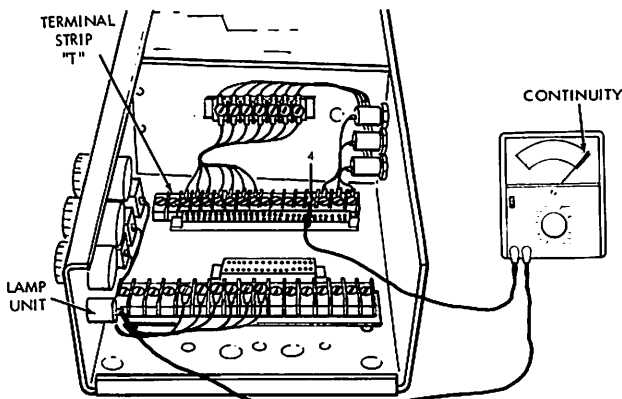

(2) If voltmeter reads 115 volts AC, set CONTROL POWER switch to OFF position, and remove fuses "FS" and "FM". Get ohmmeter.

(3) Check continuity of lamp unit leads from terminal 4 of terminal strip "T" to return side of lamp unit, and from input terminal of fuseholder "FS" to lamp unit input terminal.

G. REPLACE BLOWN FUSES:

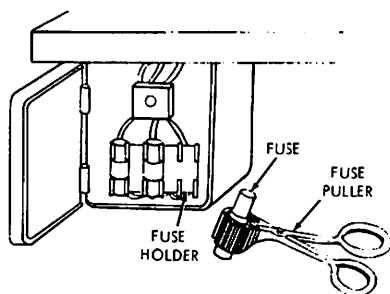

(1) If either fuse did not read continuity (paragraph B) use a fuse puller to remove bad fuse and replace with new fuse of proper type and value. Refer to REPAIR PARTS LIST for fuse part numbers.

(2) After replacing bad fuse, recheck system. (Refer to paragraph A). If system operates properly, operate unit through several cycles to ensure that fuse does not blow again.

H. CHECK CONTROL POWER SWITCH:

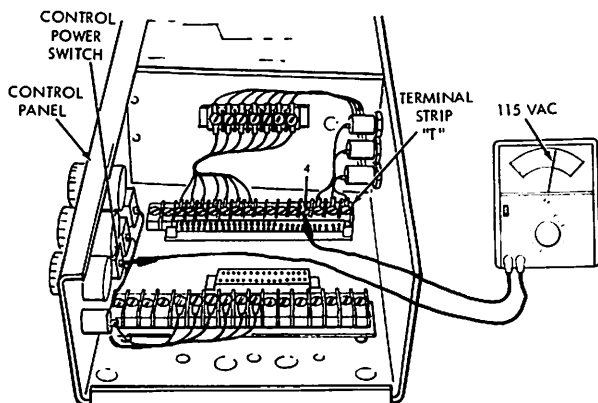

(1) If system power checks good, (paragraph C) connect one lead of voltmeter to terminal 4 of terminal strip "T" and connect other lead to output side of CONTROL POWER switch on high voltage circuit.

(2) Operate CONTROL POWER switch while observing voltmeter indication. Voltmeter should read 115 volts AC when switch is in ON position, and zero when switch is in OFF position.

(3) If power is not present at output side of CONTROL POWER switch, connect one lead of voltmeter to terminal 4 of terminal strip "T" and connect other lead to input side of CONTROL POWER switch. Voltmeter should read 115 volts AC.

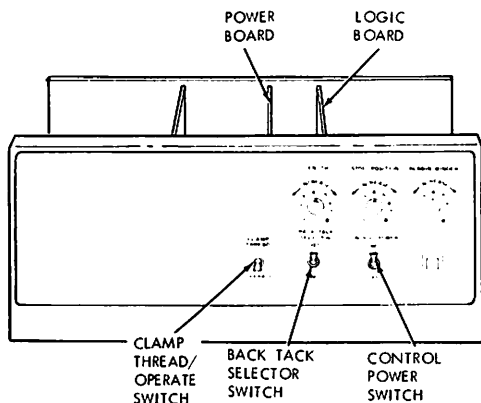

(4) If power is present at input side of CONTROL POWER switch, replace switch. Refer to REPAIR PARTS LIST, for replacement part number.

(5) If power is not present at input side of CONTROL POWER switch, transformer is defective.

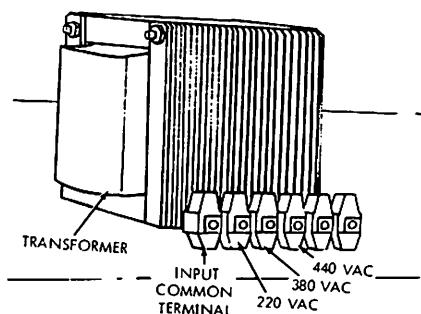

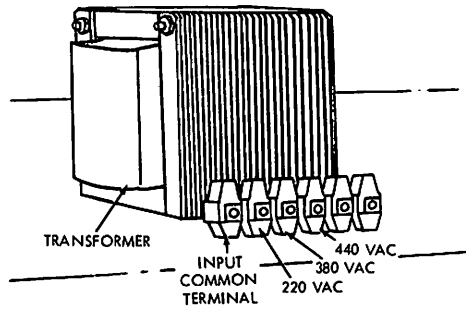

I. CHECK DRIVE MOTOR:

(1) If fuse blows after replacement, set MAIN POWER switch to OFF position and remove rear cover from bottom of control box.

(2) Disconnect one power input lead from control power transformer. Tape end of lead to ensure that it does not cause damage to equipment or injury to personnel.

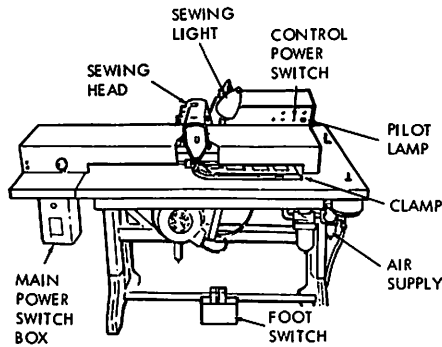

(3) Replace fuse and set MAIN POWER switch to ON position. If fuse does not blow with transformer disconnected, transformer is defective.

(4) If fuse blows with control power transformer disconnected, drive motor is defective. Refer to REPAIR PARTS LIST for replacement part number.

2. CLAMP DOES NOT GO DOWN WHEN FOOT SWITCH IS ACTUATED TO FIRST STEP.

ITEM NO. 2

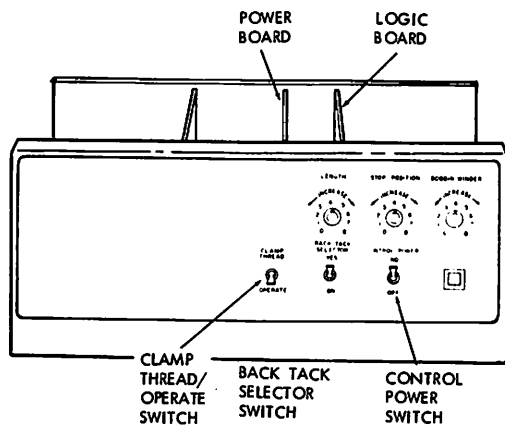
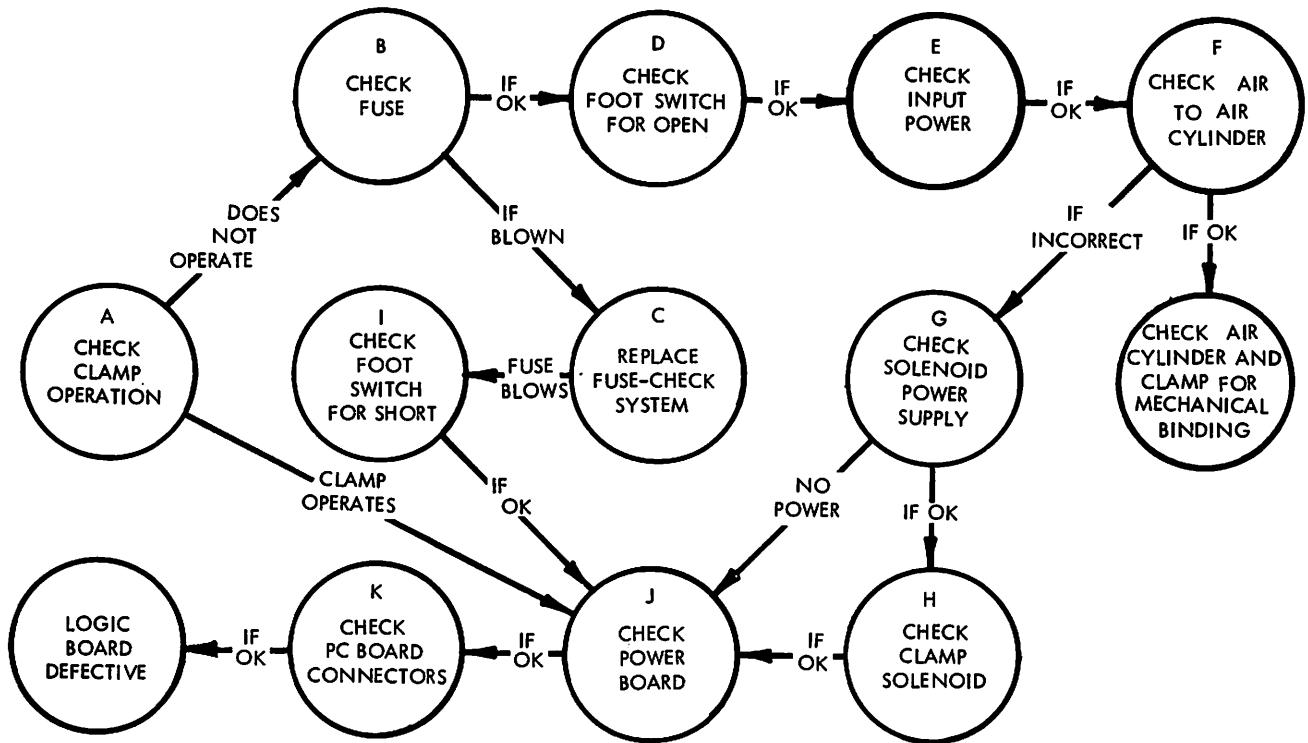

A. CHECK CLAMP OPERATION:

- (1) With MAIN POWER and CONTROL POWER switches in ON position, set CLAMP switch to THREAD position.
- (2) If clamp goes down when CLAMP switch is set to THREAD position, go to paragraph J.

NOTE

If fuse "FL" is blown, clamp will also go down when clamp switch is set to thread position.

B. CHECK FUSE:

- (1) If clamp does not go down when CLAMP switch is set to THREAD position, remove fuse holder "FS" on rear of control box and check fuse.

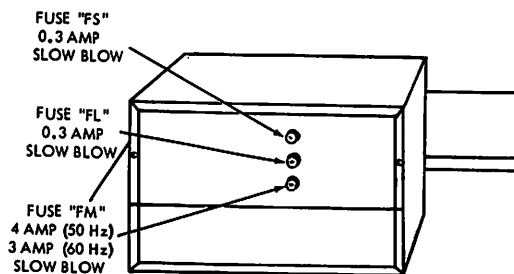

2. CLAMP DOES NOT GO DOWN WHEN FOOT SWITCH IS ACTUATED TO FIRST STEP.

ITEM NO. 2

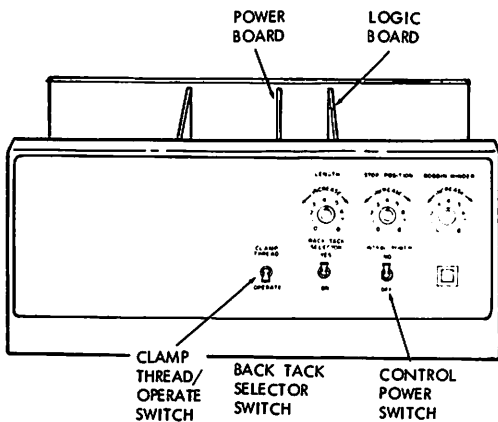
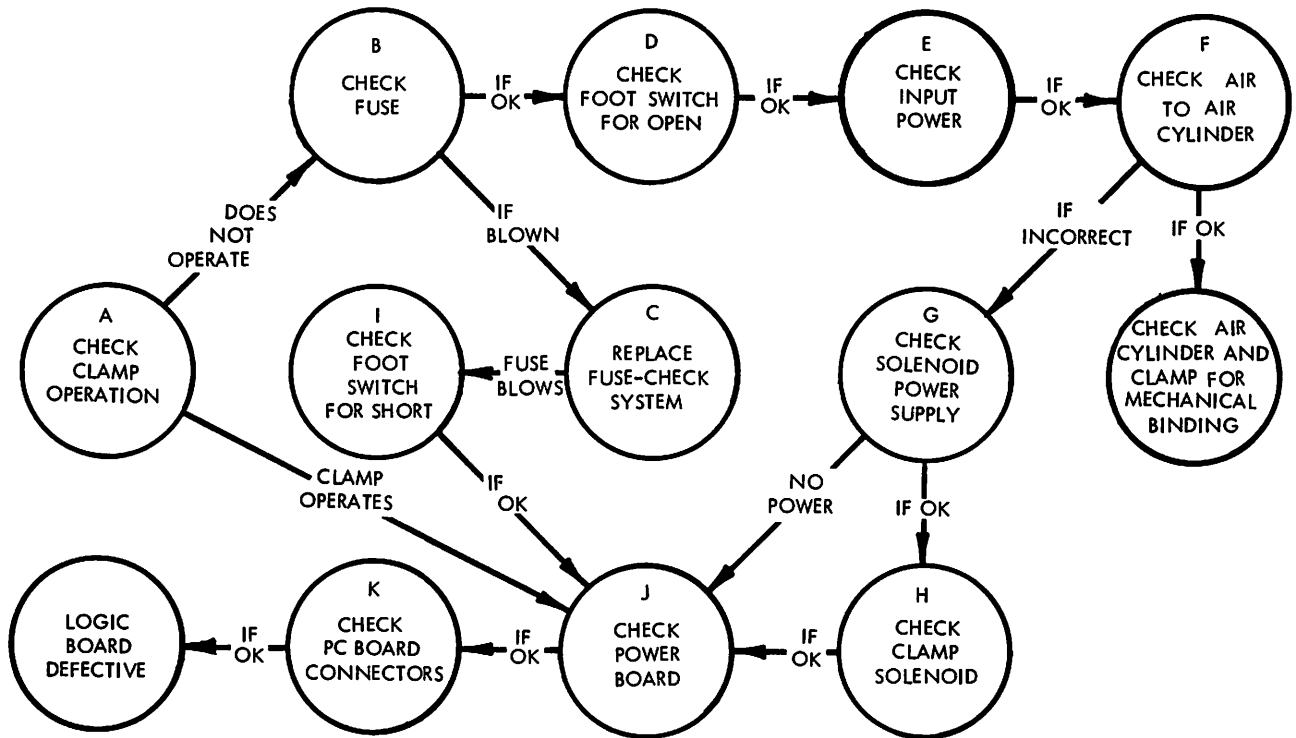

A. CHECK CLAMP OPERATION:

- (1) With MAIN POWER and CONTROL POWER switches in ON position, set CLAMP switch to THREAD position.
- (2) If clamp goes down when CLAMP switch is set to THREAD position, go to paragraph J.

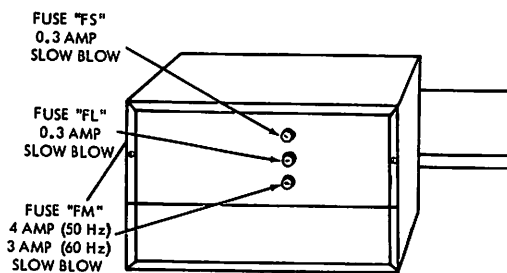

B. CHECK FUSE:

- (1) If clamp does not go down when CLAMP switch is set to THREAD position, remove fuse holder "FS" on rear of control box and check fuse.

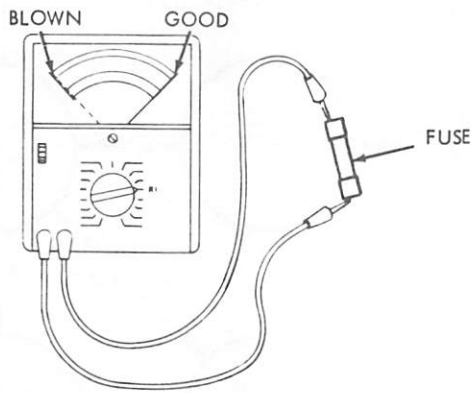

(2) If fuse does not appear to be blown, verify fuse condition by checking fuse with ohmmeter. If fuse is good, go to paragraph D.

C. REPLACE FUSE – CHECK SYSTEM:

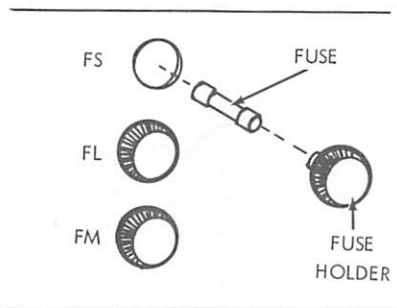

(1) If fuse is blown, remove cover from control box. Pull out power board, then replace fuse with new fuse of proper value, as indicated in REPAIR PARTS LIST.

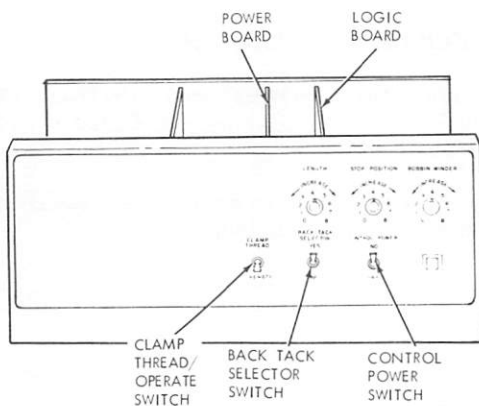

(2) Recheck system with power board removed. If fuse does not blow with power board removed, install power board and check system again. If fuse blows when power board is installed, replace power board with new item. Refer to REPAIR PARTS LIST for replacement part number.

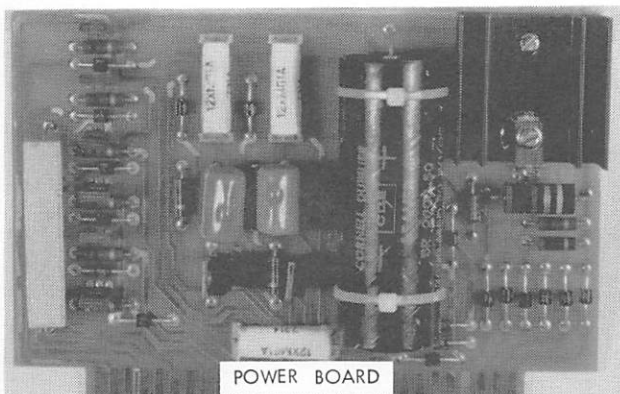

(3) If fuse blows with power board removed, or if fuse still blows after new power board is installed, go to paragraph I.

(4) If fuse does not blow after replacement, and system operates normally, operate equipment through a few cycles to ensure that fuse does not blow, then return unit to service.

D. CHECK FOOT SWITCH FOR OPEN:

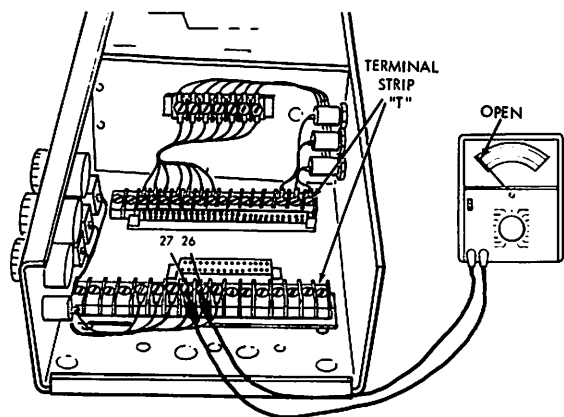

(1) If fuse is not blown, set MAIN POWER and CONTROL POWER switches to OFF position. Remove cover from control box and pull out both printed circuit boards. Get ohmmeter.

(2) Connect ohmmeter leads to terminals 26 and 27 on terminal strip "T" inside control box. Ohmmeter should read open.

(3) Actuate foot switch to first stop. Ohmmeter should read continuity.

(4) If ohmmeter does not read continuity when foot switch is actuated, disassemble foot switch and check for continuity between terminal 26 and normally open contact of switch No. 1, and between terminal 27 and common of switch No. 1. If either lead reads open, physically trace wire to locate break.

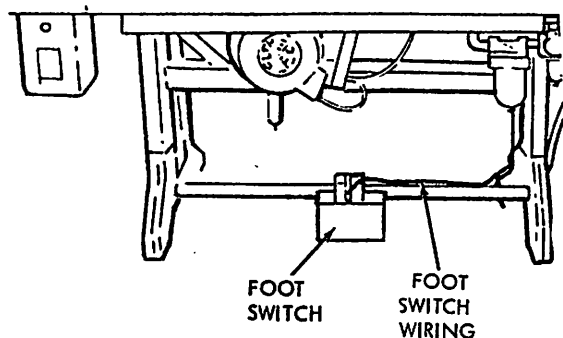

(5) If both leads check good, switch No. 1 is defective. Refer to REPAIR PARTS LIST for replacement part number.

E. CHECK INPUT POWER:

(1) If fuse is not blown, check pilot light. If pilot light is not lit, go to Item 1.

(2) If pilot light is lit, input power source is OK.

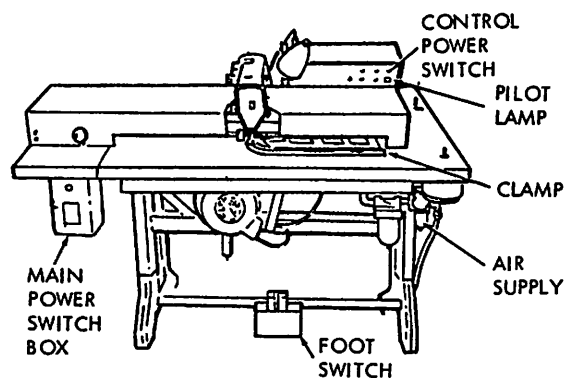

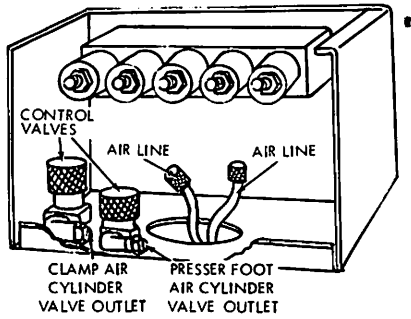

F. CHECK AIR SUPPLY TO AIR CYLINDERS:

- (1) If input power is OK, remove air hoses from clamp and presser foot air control valves.
- (2) Turn power on. Air should come from both air control valves at fittings from which hoses were removed.

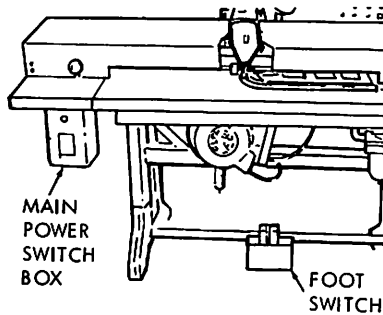

- (3) Press foot switch to first step. Air should turn off at both air control valves. If air supply checks good, go to paragraph L.

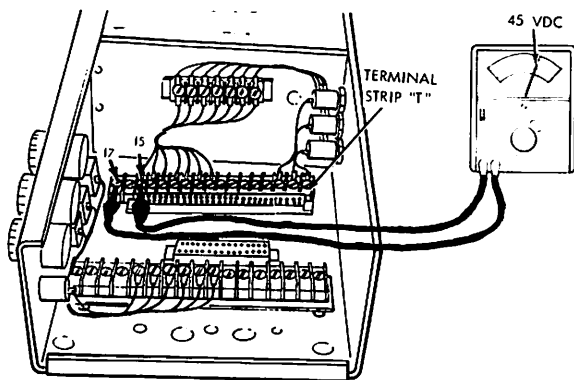

G. CHECK SOLENOID POWER SUPPLY:

- (1) If air continues to come from control valves when foot switch is actuated to first step, get a voltmeter capable of reading in 45 volt DC range.
- (2) Connect positive (+) probe of voltmeter to terminal 15 and connect negative (-) probe to terminal 17 of terminal strip "T". Voltmeter should read approximately 45 volts DC.

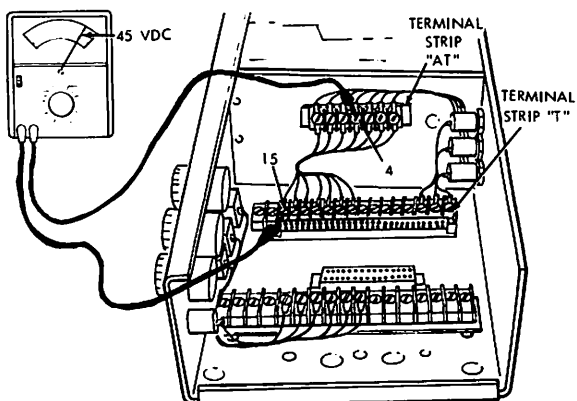

- (3) If voltmeter does not read 45 volts DC, get ohmmeter and check for continuity between terminal 15 on terminal strip "T" and terminal 4 on terminal strip "AT". If continuity checks good, go to paragraph J.

H. CHECK CLAMP SOLENOID:

(1) If solenoid power supply checks good, get a jumper lead with insulated alligator clips on both ends.

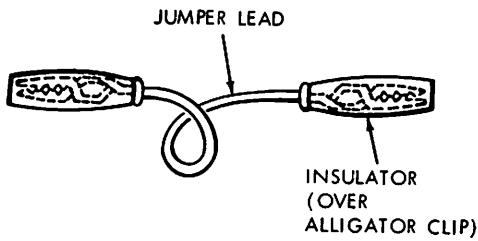

(2) With air hoses still disconnected from clamp and presser foot air control valves, connect jumper lead between terminals 15 and 17 on terminal strip "T". If air does not stop when jumper lead is installed, replace solenoid "C".

(3) If air stops when jumper lead is connected, go to paragraph J.

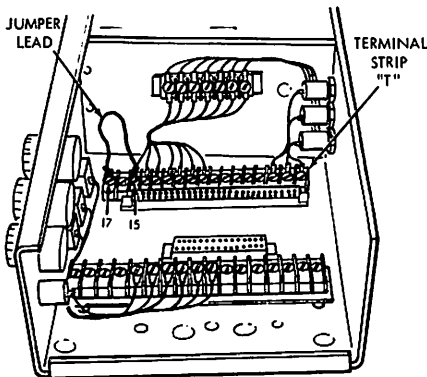

I. CHECK FOOT SWITCH FOR SHORT:

(1) If fuse blows when replaced, set MAIN POWER and CONTROL POWER switches to OFF position. Remove cover from control box and pull out power and logic boards. Get ohmmeter.

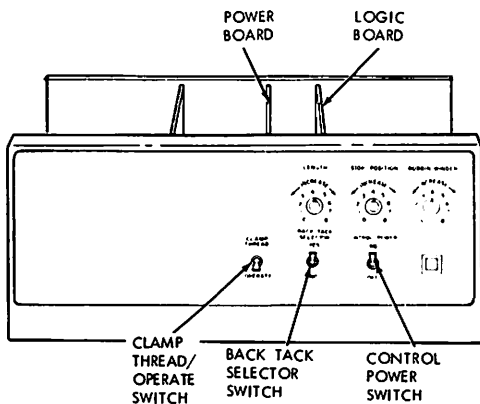

(2) Connect ohmmeter leads to terminals 26 and 27 on terminal strip "T" inside control box. Ohmmeter should read open.

(3) If ohmmeter reads continuity between terminals 26 and 27 with foot switch in unactuated position, disconnect one lead from terminal strip and check from end of lead to other terminal. If meter still reads continuity, disassemble foot switch housing.

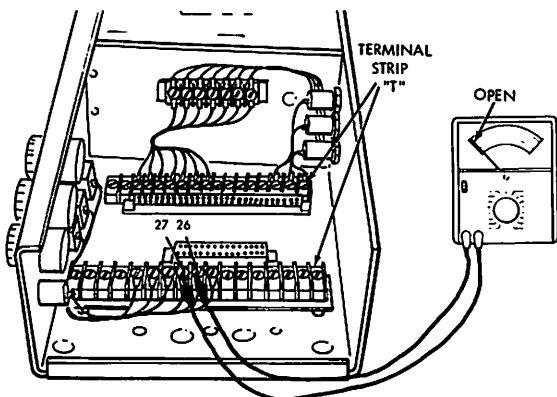

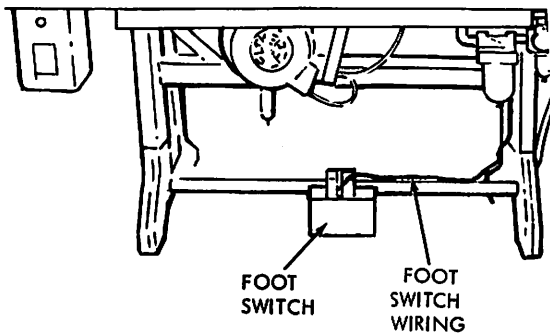

(4) Disconnect leads from switch No. 1 and check for continuity between leads. If ohmmeter reads open, switch is defective.

(5) If ohmmeter still reads continuity, switch wiring is defective.

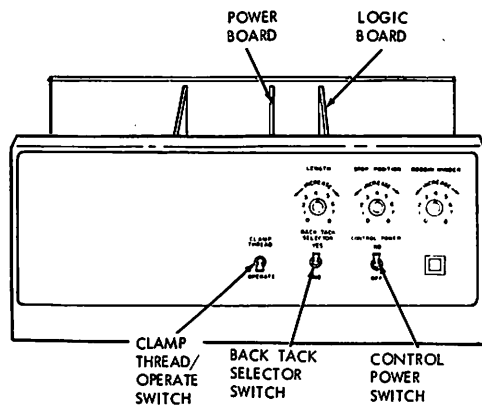

J. CHECK POWER BOARD:

(1) If clamp operates (paragraph A), or if there is no power to clamp solenoid (paragraph G), if clamp solenoid checks good (paragraph H), or if foot switch checks good (paragraph I), remove top cover from control box.

(2) Set CONTROL POWER switch to OFF position, and remove logic board.

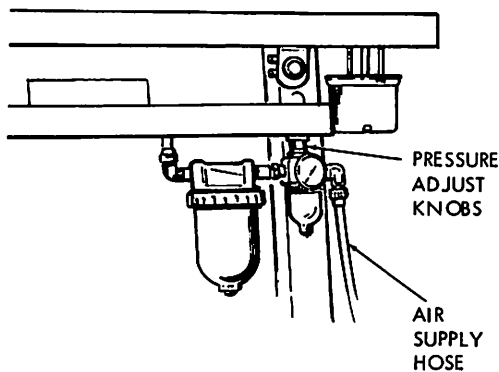

(3) Check air supply pressure gauge to ensure that air pressure is set within specified range.

(4) With clamp in home position, set BACK TACK SELECTOR switch to YES position, and CLAMP THREAD/OPERATE switch to OPERATE position.

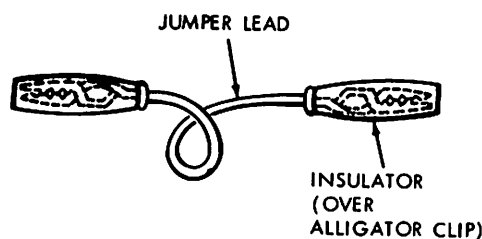

(5) Get voltmeter capable of reading 12 volts DC, 45 volts DC, 90 volts DC, 24 volts AC, and 115 volts AC.

(6) Get two 18-inch jumper leads with insulated alligator clips on both ends.

ITEM NO. 2

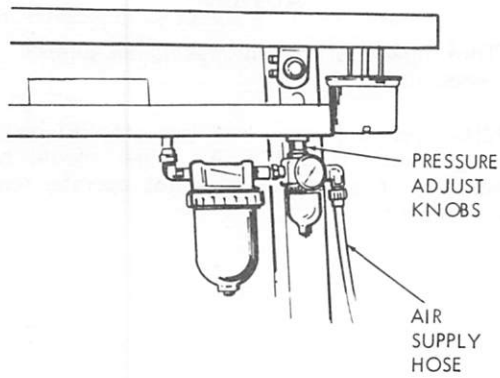

(7) Disconnect air supply hose. Clamp and presser foot should go down. If clamp and presser foot do not go down, check clamp mechanism for mechanical bind.

(8) Set CONTROL POWER switch to ON position. Machine should not run. If machine runs, replace power board.

(9) Perform voltage checks as follows:

VOLTMETER CONNECTIONS		Voltage Reading
Positive Probe	Negative Probe	
Terminal Strip "T" 1 Terminal Strip "T" 3 Terminal Strip "T" 4	Terminal Strip "T" 2 Terminal Strip "T" 4 Terminal Strip "T" 17	24 VAC 115 VAC 45 VDC (or 115 VAC half wave)
Terminal Strip "T" 8	Terminal Strip "T" 17	90 VDC (or 115 VAC full wave)
Test Terminal "H" Clutch Terminal Blue Lead	Test Terminal "G" Clutch Terminal Black Lead	12 VDC 5-10 VDC

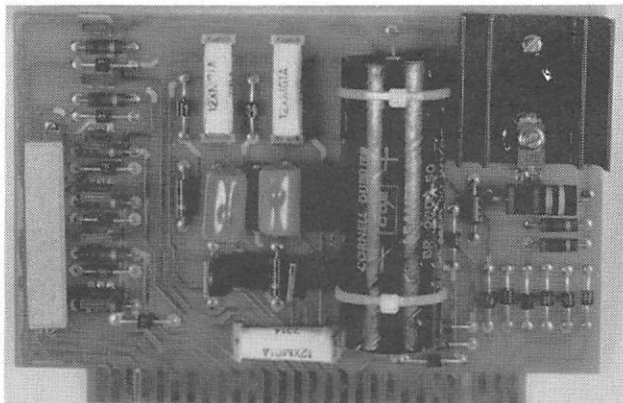

(10) If first two voltages are incorrect, remove power board and recheck. If voltages are correct with power board out, install new power board. If any other voltages are incorrect, replace power board. Refer to REPAIR PARTS LIST for replacement part number.

(11) If all voltage readings are correct, connect air pressure source to system. Clamp and presser bar should lift.

CAUTION

Turn power off when making all jumper connections.

(12) Connect a jumper lead (see step (6)) between test terminals H and J. Air wiper should begin operating. If air wiper does not operate, replace power board.

(13) If air wiper begins operating when jumper is connected between test terminals H and J, remove jumper lead and connect it between test terminals P and H, and connect voltmeter leads across terminals of electric clutch. Air wiper operation should stop, clamp should go down, and presser bar should be lowered. Voltmeter should read 90 volts DC. If any of these events do not occur, replace power board.

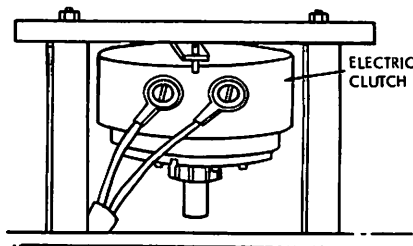
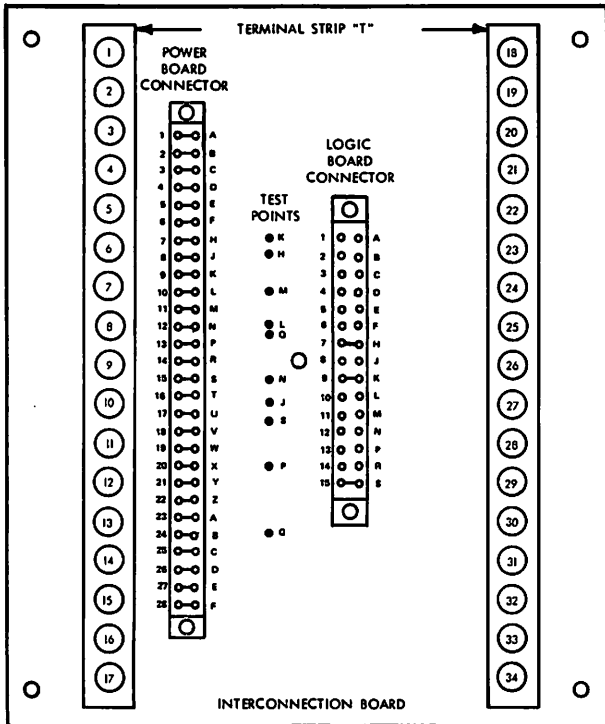

(14) If proper results are achieved with jumper between test terminals H and P, remove jumper and connect it between test terminals H and S, leaving voltmeter connected between electric clutch terminals. Clamp and presser bar should rise, and voltmeter indication should go to 5 - 10 volts dc. Back tack cylinder should operate. If any of these events fail to occur, replace power board.

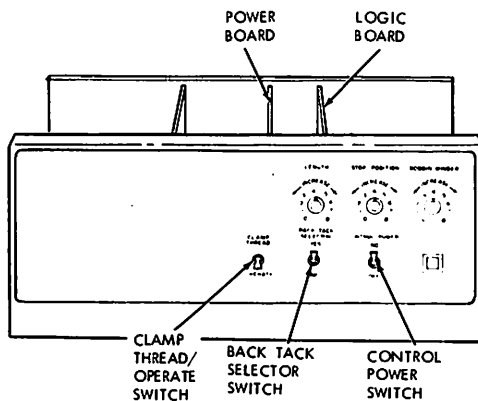

(15) If proper results are achieved with jumper lead connected between test terminals H and S, set CLAMP switch to THREAD position. Clamp and presser bar should go down. If clamp and presser bar do not go down, replace power board.

ITEM NO. 2

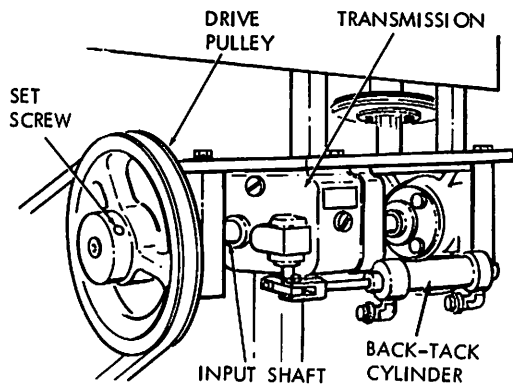

(16) If clamp and presser bar go down when CLAMP switch is set to THREAD position, remove jumper lead and connect it between test terminals H and N. Back tack cylinder should return to its home position, and machine should run at high speed. If either of these events fails to occur, replace power board.

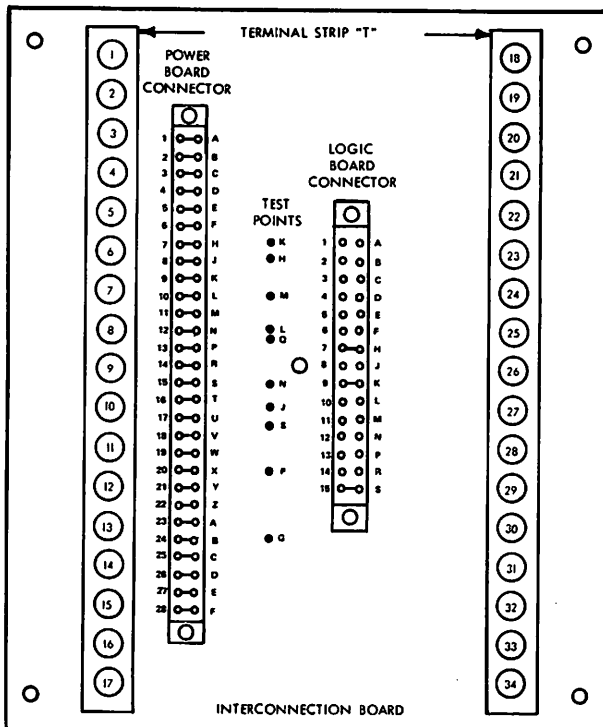

(17) If proper results are achieved with jumper connected between terminals H and N, remove jumper lead and connect it between test terminals H and K. Machine should go from high speed to low speed. If machine does not go to low speed, replace power board.

(18) If machine goes into low speed, remove jumper lead. Machine should stop, position, and trim. If machine does not stop, position, and trim when jumper is removed, replace power board.

(19) If machine stops, positions, and trims when jumper lead is removed, set CLAMP switch to OPERATE position, clamp and presser bar should lift. If clamp and presser bar do not lift, replace power board.

(20) If clamp and presser bar lift, manually move clamp out of home position.

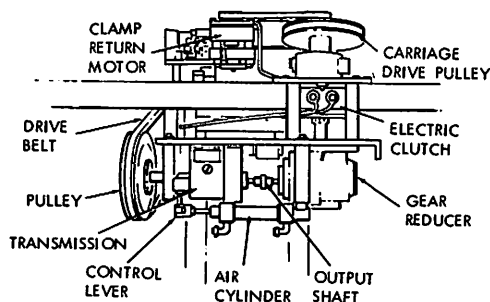

(21) Connect one jumper lead between test terminals H and Q, and connect another jumper lead between test terminals G and L. Clamp return motor should drive clamp toward home position, and motor should stop when home position is reached. If clamp return motor does not operate properly, replace power board.

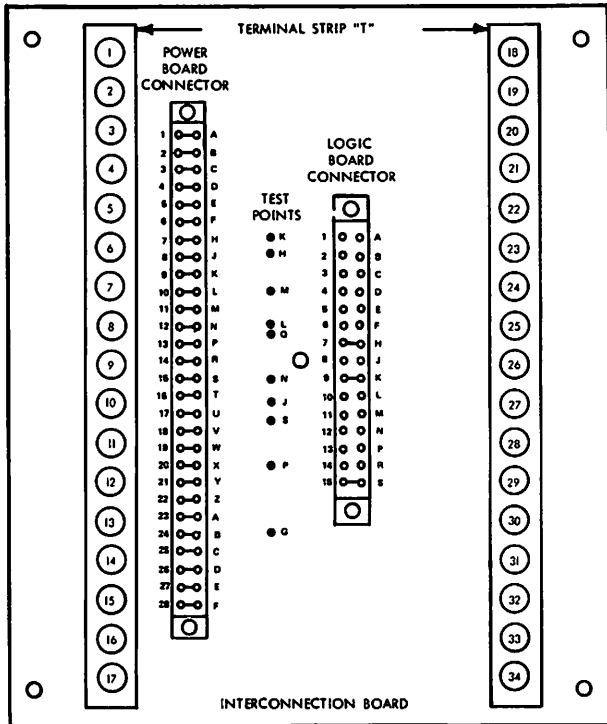

(22) If clamp motor drives clamp toward home position, remove jumpers and connect a jumper lead between test terminals G and M. Bobbin motor should run. If bobbin motor does not run, replace power board.

(23) If bobbin motor runs, remove jumper lead. Bobbin motor should stop running. If bobbin motor does not stop, replace power board.

K. CHECK P.C. BOARD CONNECTORS:

(1) If power board checks good, turn off power and remove power board from control box. Get an ohmmeter.

(2) Perform continuity check of logic board connector as follows:

FROM TERMINAL STRIP "T" TERMINAL	TO LOGIC BOARD CONNECTOR PIN
20	A
21	C and H
22	D
23	B
24	E
25	F
26	D
27	K
28	M
29	L
30	J
31	N
32	P
33	R
34	S

FROM TEST POINT	TO LOGIC BOARD CONNECTOR PIN
K	1
H	2
M	4
L	6
Q	7 and H
N	8
J	9 and K
S	10
P	14
G	15 and S

(3) If any of the above circuits do not read continuity, replace interconnection board. Refer to REPAIR PARTS LIST for replacement part number.

ITEM NO. 2

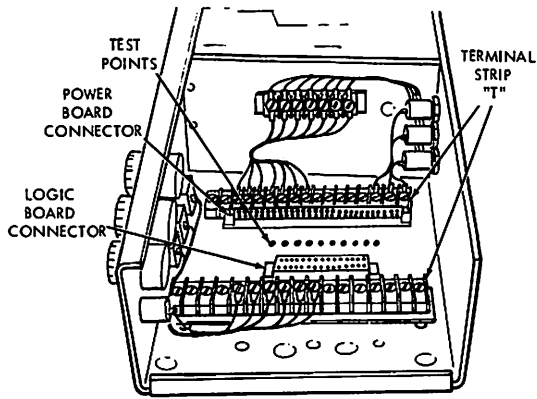

(4) Perform continuity check of power board connector as follows:

FROM LOGIC BOARD CONNECTOR PIN	TO POWER BOARD CONNECTOR PIN
1	11 and M
2	12 and N
4	13 and P
6	14 and R
7 and H	15 and S
8	16 and T
9 and K	17 and U
10	18 and V
14	19 and W
15 and S	28 and F

FROM TERMINAL STRIP "T" TERMINAL	TO POWER BOARD CONNECTOR PIN
1	1 and A
2	2 and B
3	3 and C
4	4 and D
5	5 and E
6	7 and H
7	6 and F
8	8 and J
9	20 and X
10	21 and Y
11	22 and Z
12	23 and A
13	26 and D
14	24 and B
15	25 and C
16	27 and E
17	28 and F
18	9 and K
19	10 and L

(5) If any of the above circuits do not read continuity, replace interconnection board. Refer to REPAIR PARTS LIST for replacement part number.

(6) If power board and P.C. board connectors check good, replace logic board. Refer to REPAIR PARTS LIST for replacement part number.

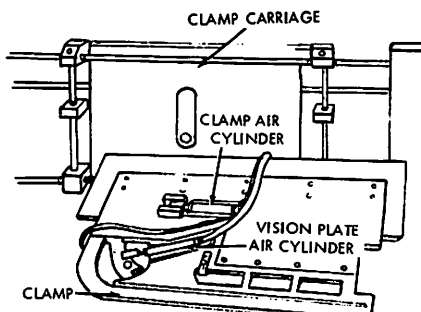

L. CHECK AIR CYLINDERS AND CLAMP FOR MECHANICAL BINDING:

(1) If air pressure turns off at air control valves when foot switch is operated, remove cover from clamp carriage assembly.

(2) Remove carriage assembly, and check clamp raise-lower mechanism for mechanical binding. With air line disconnected from air cylinder, clamp should move freely in both directions.

3. MACHINE DOES NOT START WHEN FOOT SWITCH IS ACTUATED TO SECOND STEP.

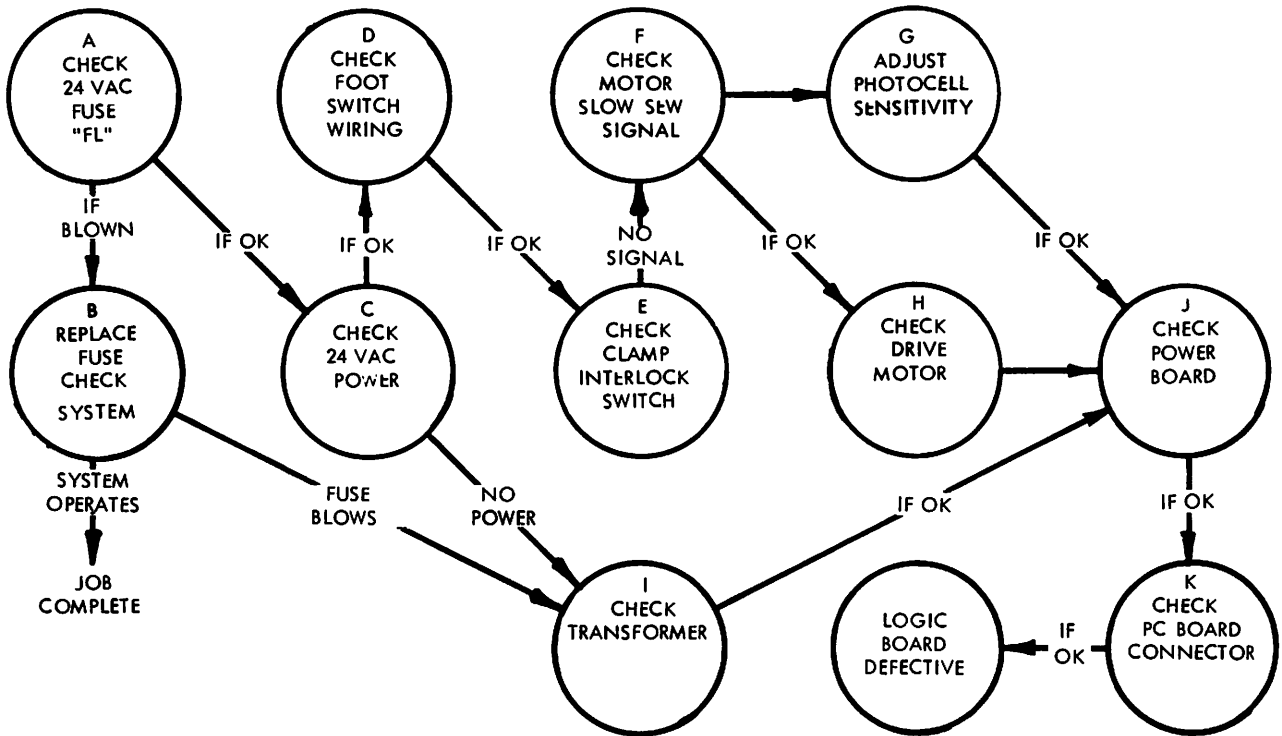

A. CHECK 24 VAC FUSE "FL":

(1) Remove fuseholder "FL" on rear of control box and check fuse.

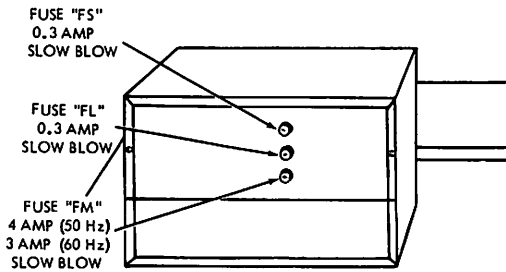

(2) If fuse does not appear to be blown, verify good fuse by checking with ohmmeter. If fuse is good, go to paragraph C.

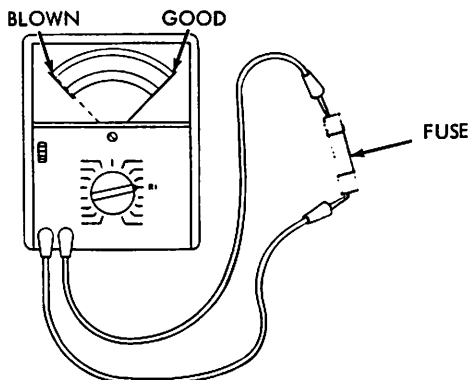

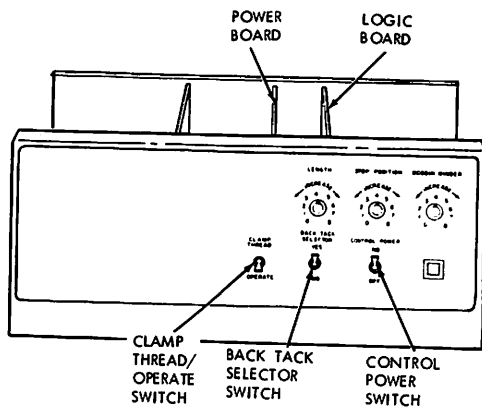

B. REPLACE FUSE, CHECK SYSTEM:

(1) If fuse is blown, remove control box cover and pull out power board, then replace fuse with new 0.3 amp fuse as specified in REPAIR PARTS LIST.

(2) Apply power to system with power board removed. If fuse blows, go to paragraph I.

(3) If fuse does not blow with power board removed, install power board and recheck system. If fuse blows when power board is installed, replace power board. Refer to REPAIR PARTS LIST for replacement part number.

(4) If fuse does not blow when power board is installed, operate unit through several cycles to ensure that fuse does not blow, then return unit to service.

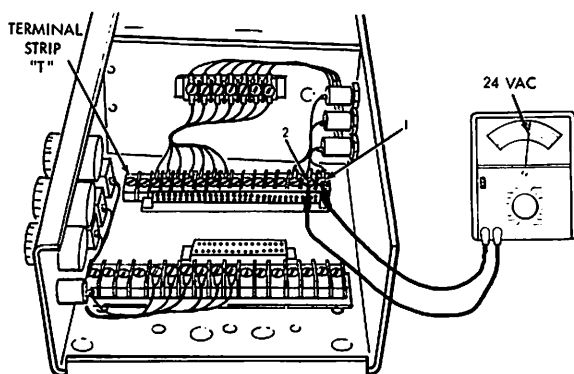

C. CHECK 24 VOLT AC POWER:

(1) If fuse checks good, remove control box cover. Get AC voltmeter capable of reading in 24 volt range.

(2) Connect voltmeter leads between terminals 1 and 2 on terminal strip "T". Voltmeter should read 24 volts AC. If voltmeter does not read 24 volts AC, go to paragraph I.

D. CHECK FOOT SWITCH WIRING:

(1) If 24 VAC power checks good, turn MAIN POWER switch off. Remove control box cover and remove power board and logic board. Get ohmmeter.

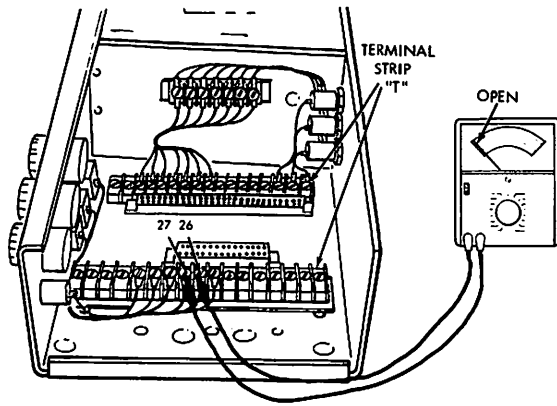

(2) Connect ohmmeter leads to terminals 26 and 27 on terminal strip "T". Ohmmeter should read open.

(3) Operate foot switch to first step. Ohmmeter should read continuity.

(4) Connect ohmmeter leads between terminals 24 and 26. Ohmmeter should read open.

(5) Actuate foot switch to second step. Ohmmeter should read continuity.

E. CHECK CLAMP INTERLOCK SWITCH:

(1) If foot switch checks good, turn unit off and disconnect air supply. Clamp should go down. If clamp does not go down, refer to Item 2 and check clamp operation.

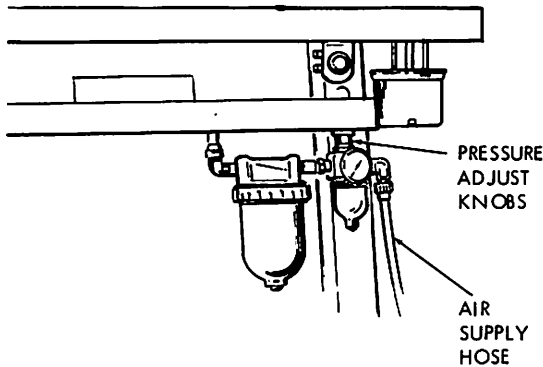

(2) Remove cover from control box and remove power board and logic board. Get ohmmeter.

(3) Connect ohmmeter leads between terminals 21 and 22 of terminal strip "T". With clamp down, ohmmeter should read open circuit.

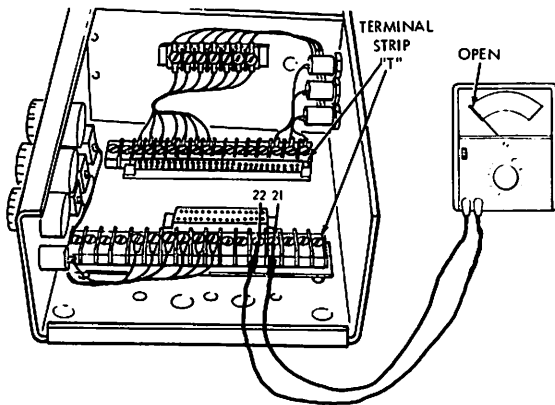

(4) With ohmmeter still connected, depress presser foot air cylinder by hand to cause clamp interlock switch lever to move slightly. Ohmmeter should read continuity as soon as switch lever moves. Switch adjustment should be such that switch opens just as clamp reaches full down position.

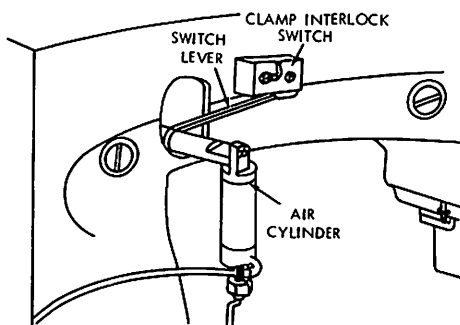

ITEM NO. 3

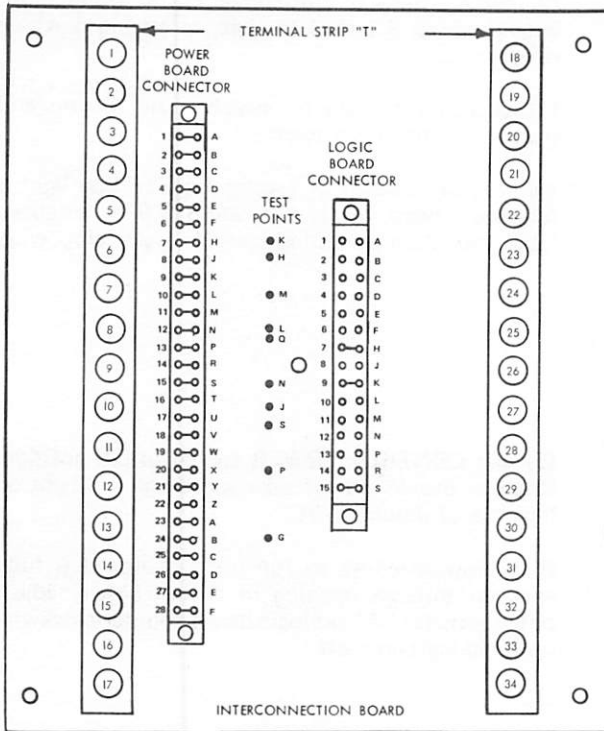

(5) If clamp interlock switch checks good, check for continuity between terminal 21 and pin C on power board receptacle. Check for continuity between terminal 22 and pin D of power board receptacle. If either lead reads open, and wires do not appear to be broken, replace interconnection board. Refer to REPAIR PARTS LIST for replacement part number.

F. CHECK MOTOR SLOW SEW SIGNAL:

(1) Remove wire that goes to motor control from terminal 18 on terminal strip "T". Leave other leads connected to terminal 18.

(2) Connect ohmmeter leads to terminals 18 and 19 of terminal strip "T". Ohmmeter should read open.

(3) Set MAIN POWER switch and CONTROL power switch to ON position, and actuate foot switch to second step. Ohmmeter reading should briefly read continuity when foot switch is actuated.

(4) If slow sew signal is OK, go to paragraph H.

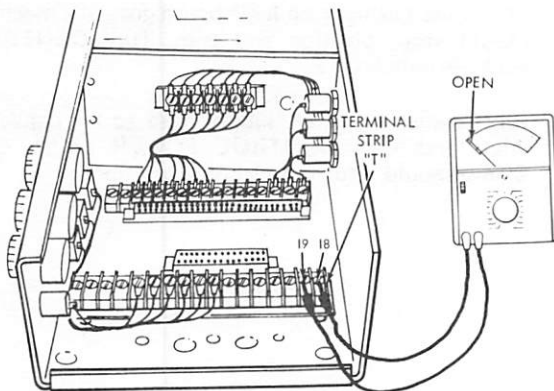

G. ADJUST PHOTOCELL SENSITIVITY:

(1) If slow sew signal is absent, turn potentiometer "B" on logic board fully clockwise. Turn CONTROL POWER switch OFF, leave MAIN POWER switch ON.

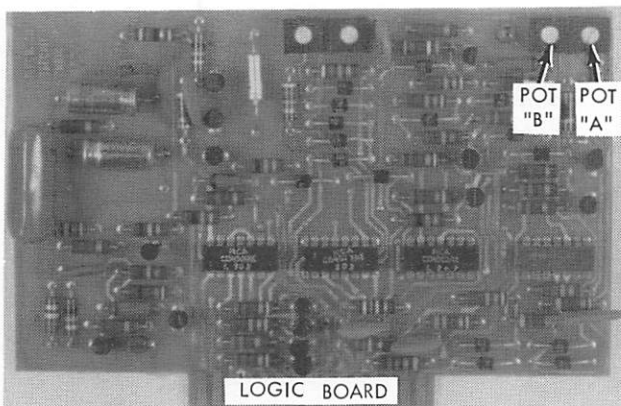

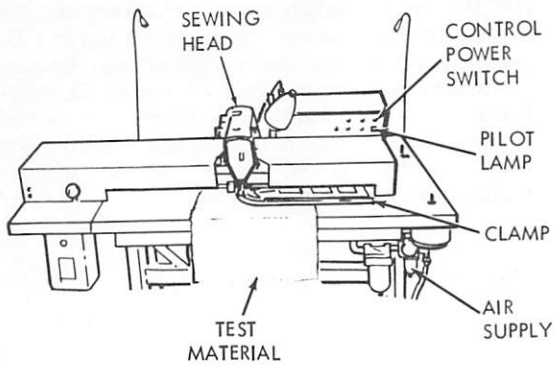

(2) Place a piece of cloth under clamp so that cloth extends 6 to 8 inches to right of sewing machine needle area.

(3) Disconnect main air supply hose. Clamp and presser bar should go down.

(4) Adjust position of sewing lamp so that light is directed toward needle area, and 8 to 9 inches above table top. Turn potentiometer "A" fully clockwise.

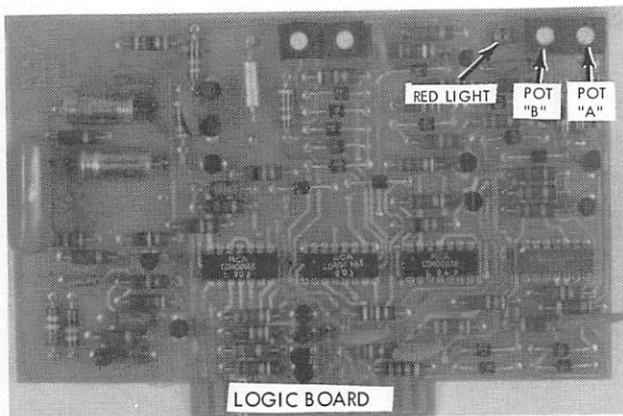

(5) Set CONTROL POWER switch to ON position. Machine should run at slow speed and red light on logic board should be lit.

(6) Allow machine to run until photocell is fully exposed through opening in clamp. Slowly adjust potentiometer "A" on logic board counter-clockwise until red light goes off.

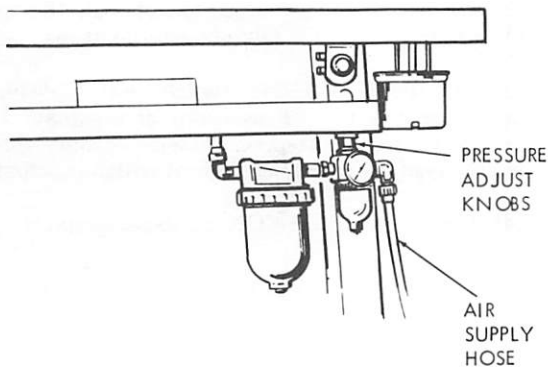

(7) When red light on logic board goes off, machine should stop, position and trim. Turn CONTROL POWER switch OFF.

(8) Connect main air supply hose to air regulator inlet, and turn CONTROL POWER switch ON. Clamp should return to its home position.

(9) Using a single layer of pants material, test machine operation. Machine should sew properly. If machine does not sew properly, rotate potentiometer "B" on logic board approximately 15 degrees counter-clockwise, then repeat steps (2) through (9). If proper operation cannot be achieved, continue to next paragraph.

H. CHECK DRIVE MOTOR:

- (1) If photocell calibration does not correct system operation, check drive motor, clutch and control panel.
- (2) Refer to motor manufacturer's instruction manual for drive motor and clutch troubleshooting procedures.
- (3) If motor checks good, go to paragraph J.

I. CHECK TRANSFORMER:

- (1) If fuse blows again after replacement (paragraph B) get AC voltmeter capable of reading in 24 volt AC range. Remove cover from control box.

- (2) Connect voltmeter leads between terminals 1 and 2 of terminal strip "T". Voltmeter should read 24 volts AC. If voltmeter reading is more than 29 volts AC, or less than 19 volts AC, refer to Item 1, paragraph C, and check system input power.

- (3) If input power is correct, transformer is defective. Refer to REPAIR PARTS LIST for replacement part number.

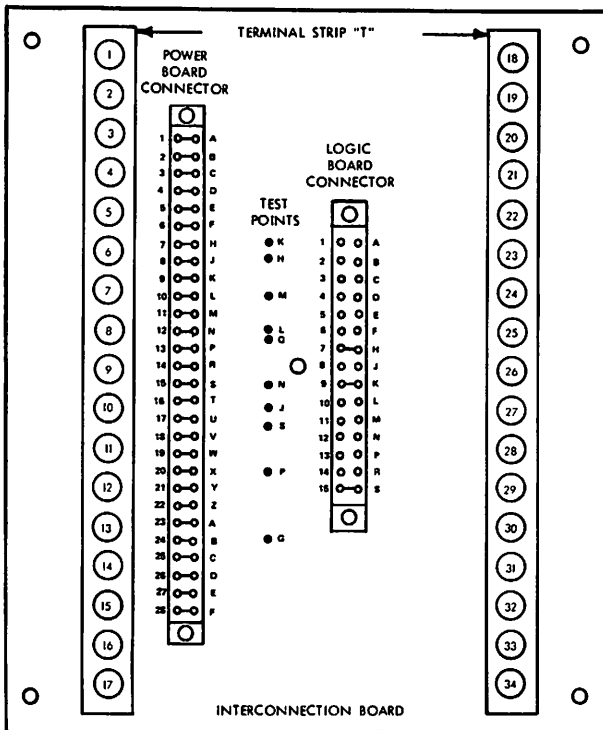

J. CHECK POWER BOARD:

- (1) If 24 VAC power is absent, and transformer checks good; if slow sew signal is absent, and photocell sensitivity adjustment does not correct the problem; or if slow sew signal is present and drive motor checks good, check power board. Remove cover from control box.

- (2) Check power board using procedure given in Item 2, paragraph J, steps (2) through (23).

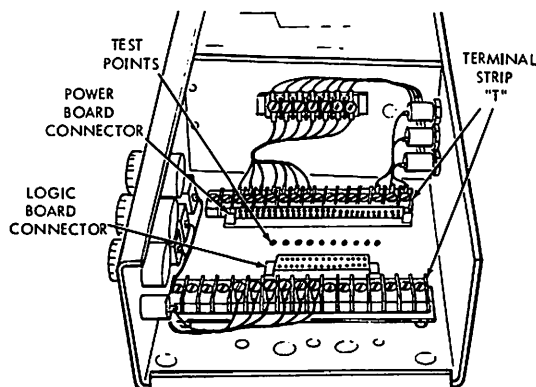

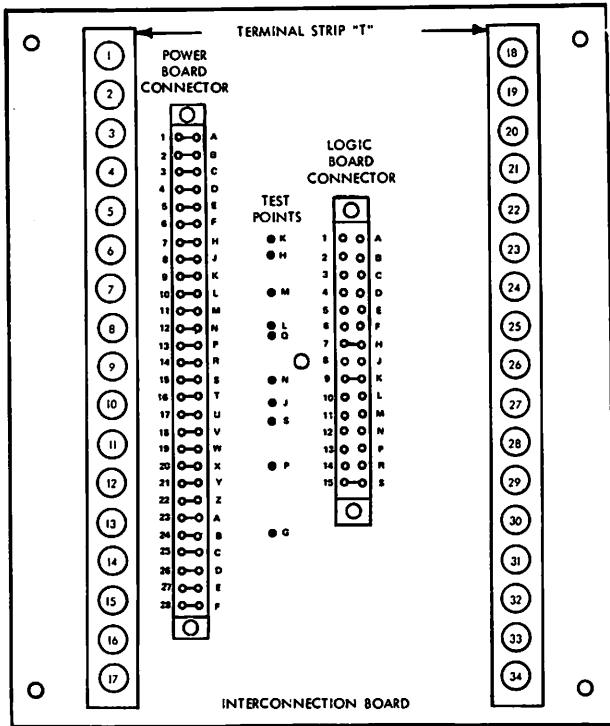

K. CHECK P.C. BOARD CONNECTORS:

(1) If power board checks good, disconnect electrical power from equipment.

(2) Check P.C. board connectors using procedure given in Item 2, paragraph K.

(3) If P.C. board connectors check good, replace logic board. Refer to REPAIR PARTS LIST for replacement part number.

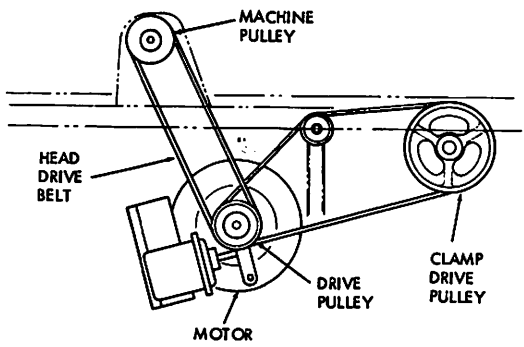
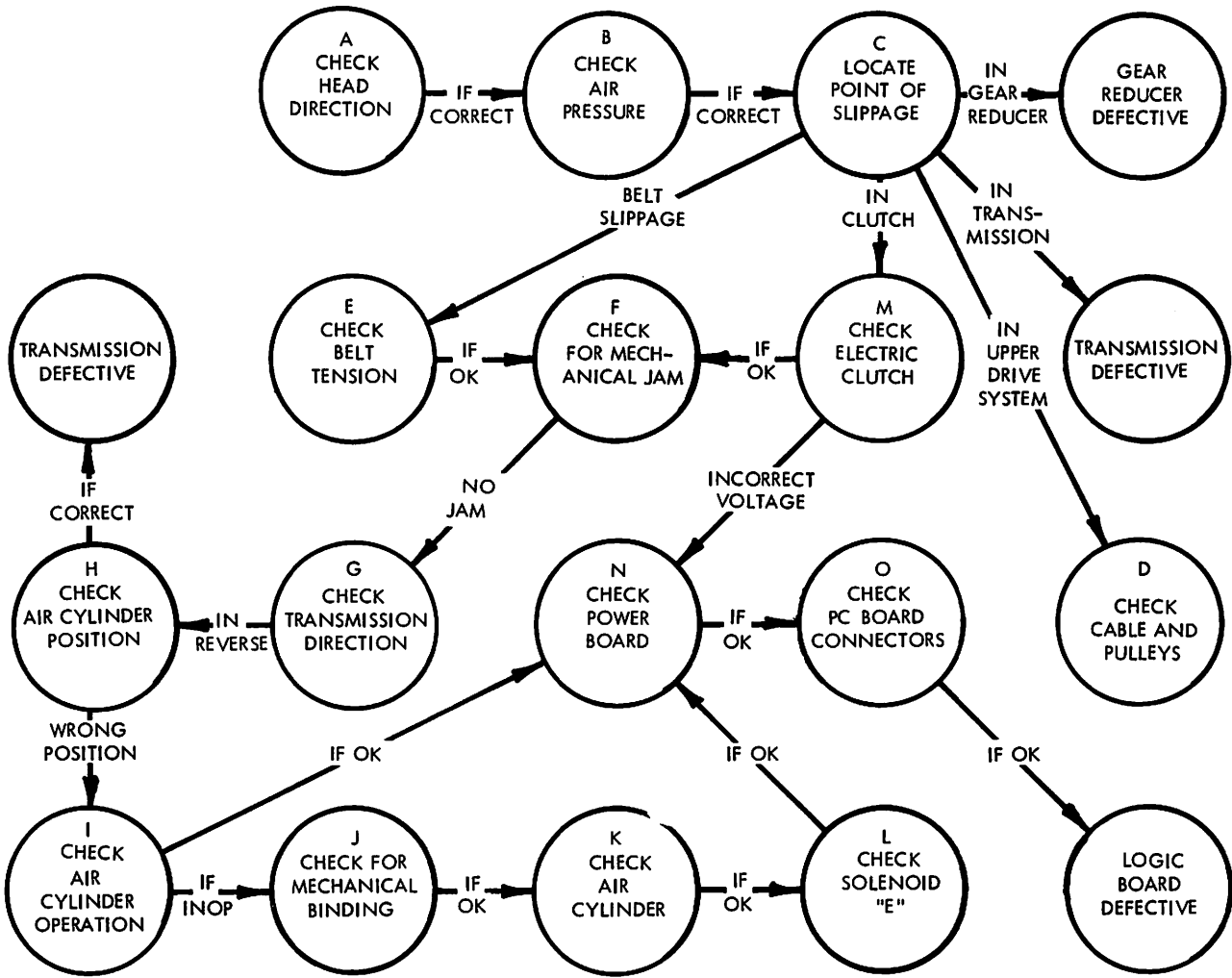

A. CHECK HEAD DIRECTION:

- (1) Operate unit and observe direction of sewing machine head drive pulley. Drive pulley rotation should be clockwise when viewed from front of machine.
- (2) If direction of drive pulley rotation is incorrect, refer to drive motor instructions and check motor.

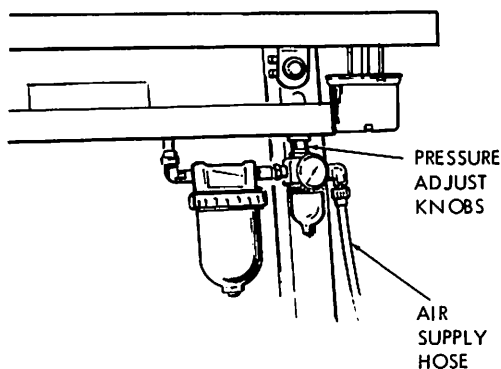

B. CHECK AIR PRESSURE:

- (1) If direction of drive pulley rotation is correct, check setting of air supply pressure regulator.
- (2) Air pressure setting should be between 40 and 45 psi. If air pressure setting is incorrect, reset pressure and check unit.

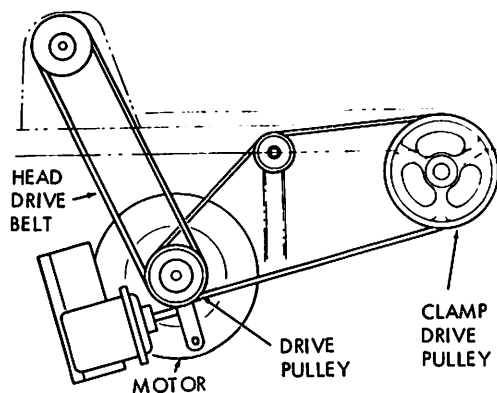

C. LOCATE POINT OF SLIPPAGE:

- (1) Check drive belt from drive motor pulley to large pulley at rear of unit. Large pulley should be driven when motor operates.
- (2) If pulley at rear of unit is turning, check belt and pulley that drives transmission. If pulley is turning, check transmission output shaft.
- (3) If output shaft is not turning, transmission is defective.

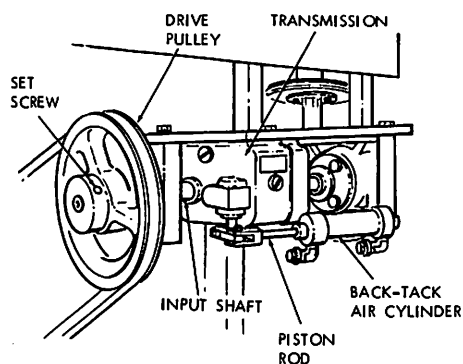

- (4) If transmission is OK, check output shaft of gear reducer. If shaft is not rotating, gear reducer is defective.
- (5) If gear reducer output shaft is turning, and carriage drive pulley is not moving, go to paragraph M.
- (6) If one or both of the drive belts slips when motor operates, go to paragraph E.

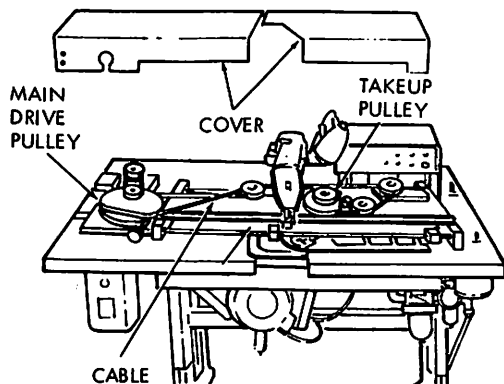

D. CHECK CABLE AND PULLEYS:

- (1) If output side of electric clutch is turning, remove cover from clamp drive carriage.
- (2) Check cable and five pulleys to ensure that cable is not damaged or improperly routed around pulleys.
- (3) Check each pulley for binding.

E. CHECK BELT TENSION:

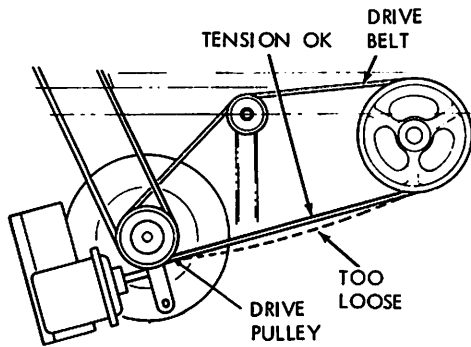

(1) If point of slippage was found to be a belt, stop unit and check belt for looseness.

(2) If horizontal span of belt runs in straight line from pulley to pulley, belt is not loose. A loose belt sags between pulleys.

F. CHECK FOR MECHANICAL JAM:

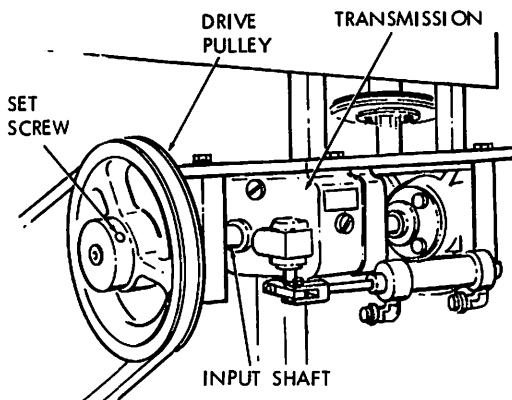

(1) If a belt is slipping, and belt tension checks OK, loosen set screw on pulley that drives transmission and allow pulley to slip on its shaft.

(2) Operate unit and check transmission drive pulley operation.

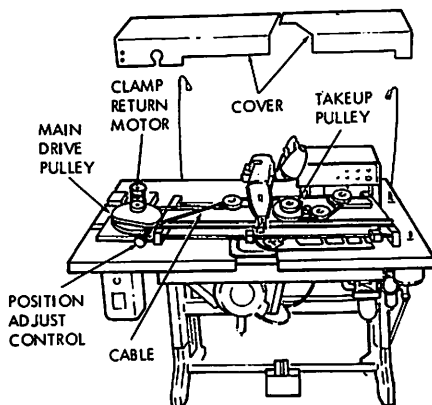

(3) If transmission drive pulley turns when allowed to slip on its shaft, remove left cover from clamp carriage mechanism, and disconnect carriage drive cable.

(4) With drive cable disconnected, manually move clamp carriage out of its home position. Carriage should move freely.

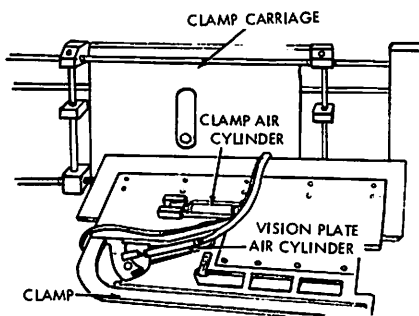

(5) If carriage does not move freely, check for binding pulleys, damaged cable, and for jams in moving parts of carriage mechanism. If pulleys and cable check good, disassemble carriage and check for damaged or corroded parts.

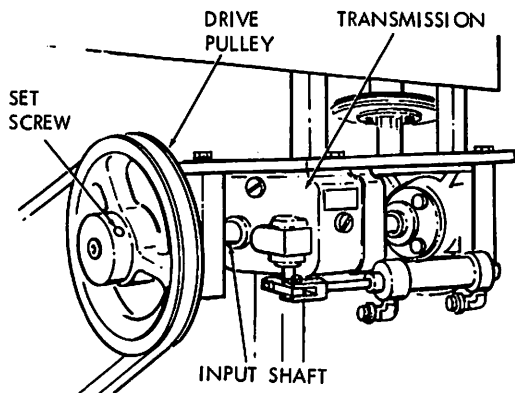

G. CHECK TRANSMISSION DIRECTION:

- (1) If clamp carriage is not mechanically jammed, manually move carriage to home position.
- (2) With transmission drive pulley free to turn on its shaft, operate unit and note direction of pulley rotation.

- (3) Remove drive belt from pulley and install set screws securing pulley to its shaft. Manually turn pulley in opposite direction from that noted in step (2).

- (4) If carriage moves out of home position when pulley is rotated, transmission is reversed.

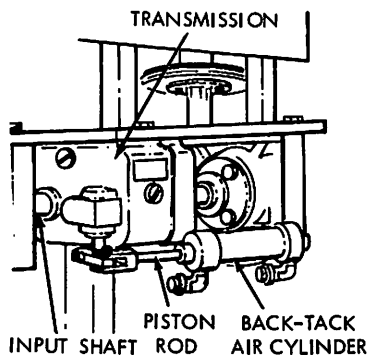

H. CHECK AIR CYLINDER POSITION:

- (1) If transmission was found to be reversed, check position of air cylinder piston rod that operates transmission control arm. Air cylinder piston rod should be in its extended position.
- (2) If piston rod is in its extended position, transmission is defective. Refer to REPAIR PARTS LIST for replacement part number.

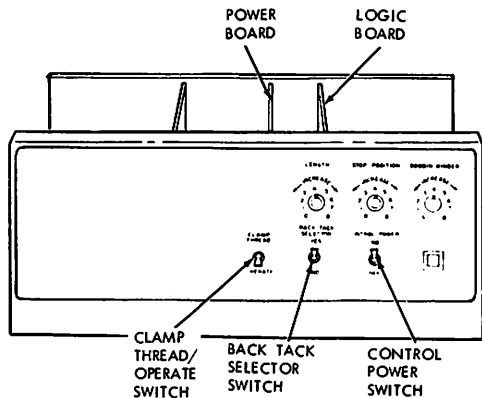

I. CHECK AIR CYLINDER OPERATION:

- (1) If air cylinder piston rod was found to be in its retracted position, set CONTROL POWER switch to OFF position, while observing piston rod.
- (2) If piston rod extends when CONTROL POWER switch is set to OFF position, go to paragraph N.

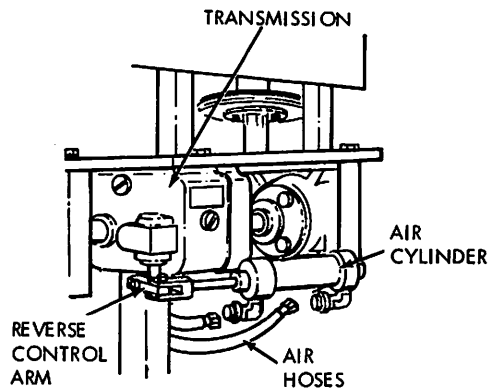

J. CHECK FOR MECHANICAL BINDING:

(1) If piston rod does not extend, remove both air hoses from air cylinder.

(2) Manually move transmission reverse control arm and air cylinder piston rod in and out. Arm and piston rod should move freely.

(3) If arm and piston rod cannot be moved, or if excessive resistance is felt, disconnect piston rod from transmission control arm and check each separately. If transmission control arm is stuck, and piston rod moves freely, transmission is defective. If piston rod is stuck, and transmission arm moves freely, air cylinder is defective. Refer to REPAIR PARTS LIST for replacement part numbers.

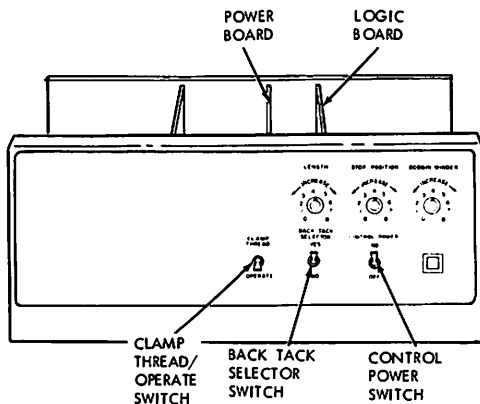

K. CHECK AIR CYLINDER:

(1) If transmission reverse control arm and air cylinder piston rod both move freely, set rod to its extended position.

(2) Set CONTROL POWER switch to ON position, and BACK-TACK switch to YES.

(3) Actuate foot switch to 2nd step and allow machine to operate through complete cycle, while observing reverse control air cylinder hoses.

(4) Initially, hose on piston end of air cylinder should have no air pressure, and air should flow from other hose. During back-tack cycle, air should flow from hose on piston rod end and other hose should have no pressure.

(5) If air flow from air cylinder hoses is correct, air cylinder is defective. Refer to REPAIR PARTS LIST for replacement part numbers.

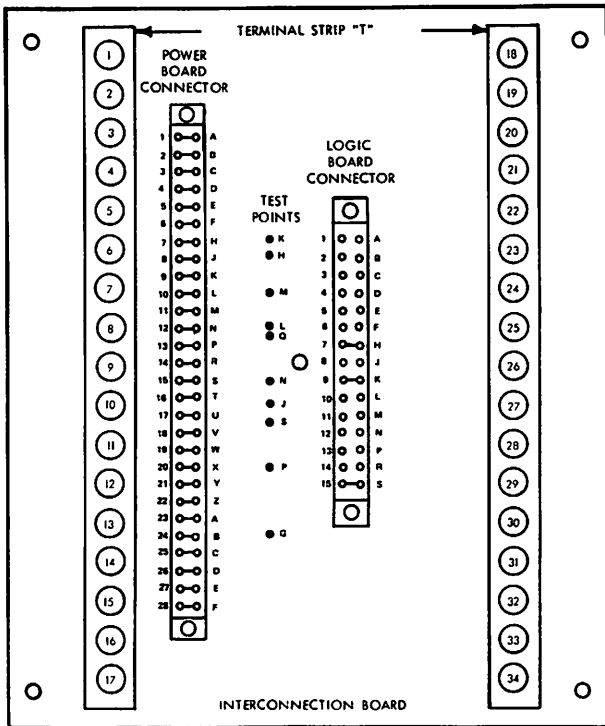

L. CHECK BACK-TACK SOLENOID:

(1) If air flow at air cylinder is not correct, get voltmeter capable of reading in 45 volt DC range, and an 18-inch jumper with insulated alligator clips on each end.

(2) Connect voltmeter positive (+) probe to terminal 4 of terminal strip "T" and connect negative (-) probe to terminal 14.

(3) Set MAIN POWER and CONTROL POWER switches to ON position. Voltmeter should read zero; there should be no pressure at air hose on piston rod end of back-tack air cylinder, and air should flow from other hose.

(4) Connect a jumper lead between terminals 14 and 17 on terminal strip "T". Voltmeter reading should go to 45 volts DC, and air should flow from hose on piston rod end of cylinder, with no pressure on other hose.

(5) If voltmeter reading is correct, and air flow is incorrect, back-tack solenoid is defective. Refer to REPAIR PARTS LIST for replacement part number.

(6) If voltmeter reading is incorrect, check solenoid wiring.

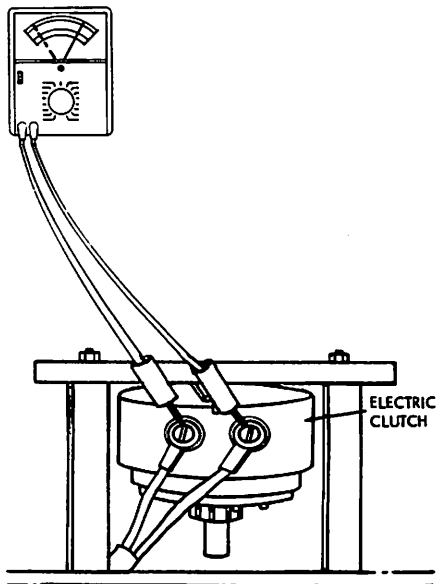

M. CHECK ELECTRIC CLUTCH:

(1) If point of slippage was found to be electric clutch, get DC voltmeter capable of reading 90 volts DC.

(2) Connect voltmeter probes to electric clutch terminals and start unit. While unit runs voltmeter should read 90 volts DC; when unit stops voltmeter should read approximately 5 volts DC.

ITEM NO. 4

(3) If clutch voltage is correct, check gear reducer shaft. If shaft is turning, electric clutch is defective or out of adjustment.

(4) If gear reducer shaft is turning and clutch voltage is not correct, remove leads from electric clutch and check voltage on leads. If voltage is correct with clutch disconnected, clutch is defective. Refer to REPAIR PARTS LIST for replacement part number.

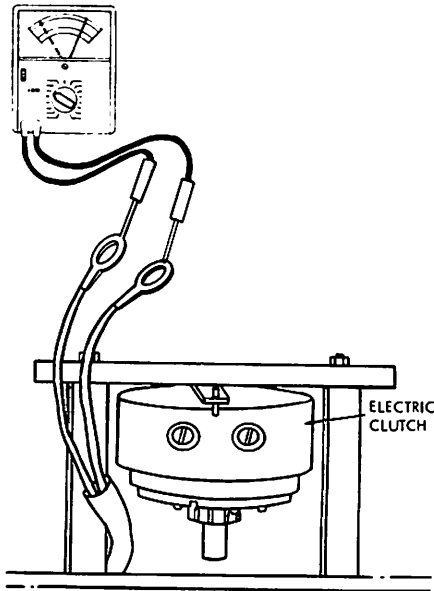

N. CHECK POWER BOARD:

(1) If solenoid checks good, or if electric clutch voltage is incorrect, remove top cover from control box.

(2) Check power board using procedure given in Item 2, paragraph J, steps (2) through (23).

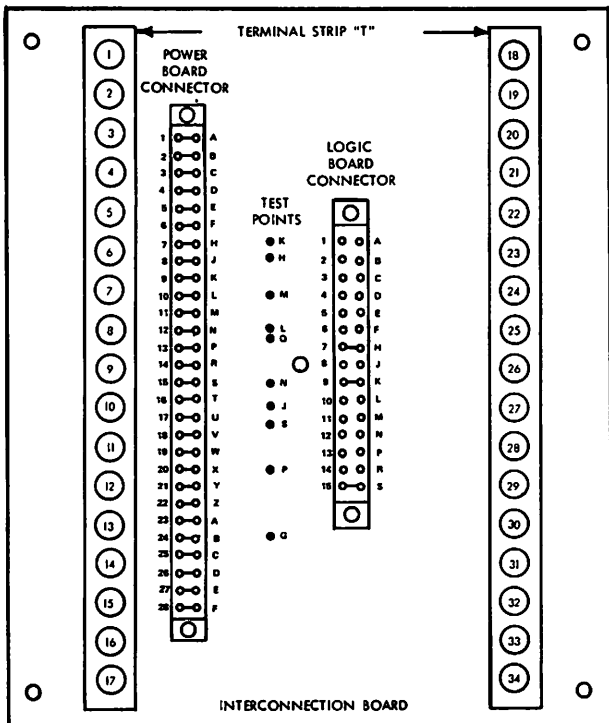

O. CHECK P.C. BOARD CONNECTORS:

(1) If power board checks good, disconnect electrical power from equipment.

(2) Check P.C. board connectors using procedure given in Item 2, paragraph k.

(3) If P.C. board connectors check good, replace logic board. Refer to REPAIR PARTS LIST for replacement part number.

5. CLAMP DOES NOT FEED IMMEDIATELY AT BEGINNING OF CYCLE

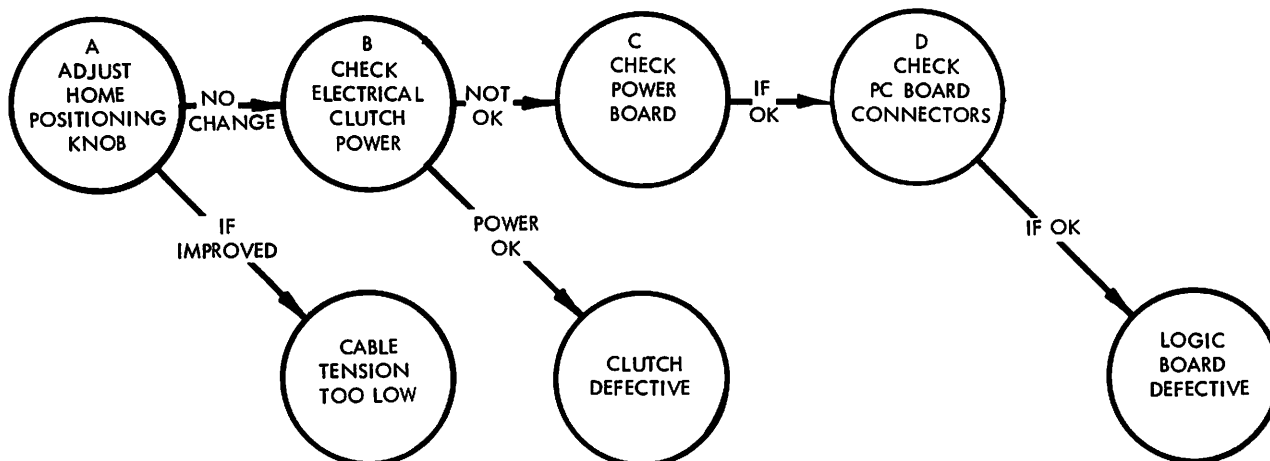

A. ADJUST HOME POSITIONING KNOB:

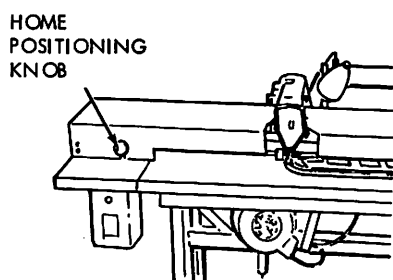

(1) Set home positioning knob counterclockwise to limit.

(2) Place a piece of material under clamp and operate unit. Machine should sew three to five stitches at a low speed, then sew fast until preselected length of seam is reached. If set for back-tacking, machine should sew preselected number of back-tack stitches at low speed. Clamp movement should vary in proportion to machine speed, keeping stitch length uniform.

(3) If home positioning knob can be adjusted to cause machine to operate properly, no further repair is required.

B. CHECK ELECTRIC CLUTCH POWER:

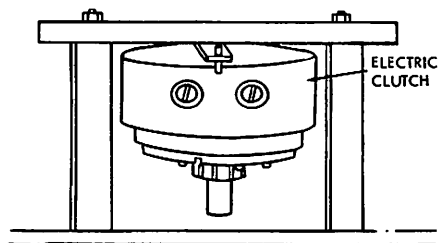

(1) If resetting home positioning knob does not improve feeding, get DC voltmeter capable of reading in 90 volt DC range.

(2) Check electric clutch power using procedure given in Item 4, paragraph L, steps (2) through (5).

(3) If clutch power is correct, electric clutch is defective.

5. CLAMP DOES NOT FEED IMMEDIATELY AT BEGINNING OF CYCLE

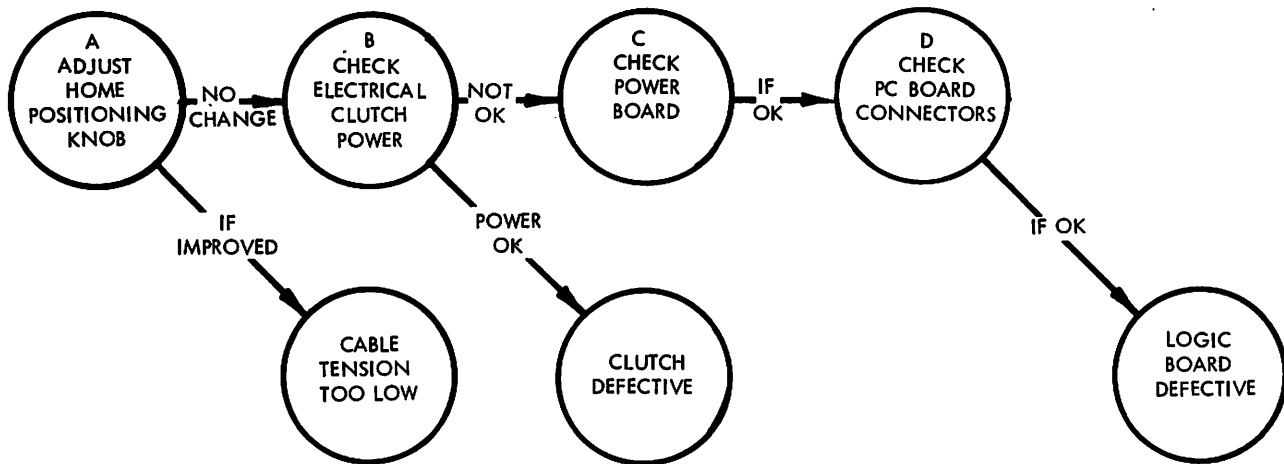

A. ADJUST HOME POSITIONING KNOB:

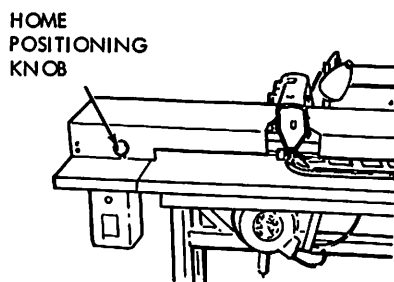

(1) Set home positioning knob counterclockwise to limit.

(2) Place a piece of material under clamp and operate unit. Machine should sew three to five stitches at a low speed, then sew fast until preselected length of seam is reached. If set for back-tacking, machine should sew preselected number of back-tack stitches at low speed. Clamp movement should vary in proportion to machine speed, keeping stitch length uniform.

(3) If home positioning knob can be adjusted to cause machine to operate properly, no further repair is required.

B. CHECK ELECTRIC CLUTCH POWER:

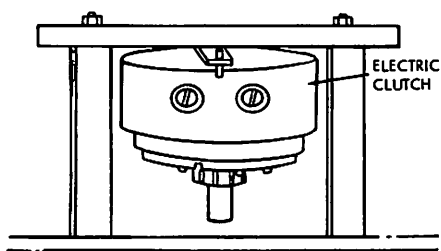

(1) If resetting home positioning knob does not improve feeding, get DC voltmeter capable of reading in 90 volt DC range.

(2) Check electric clutch power using procedure given in Item 4, paragraph M, steps (2) through (5).

(3) If clutch power is correct, electric clutch is defective.

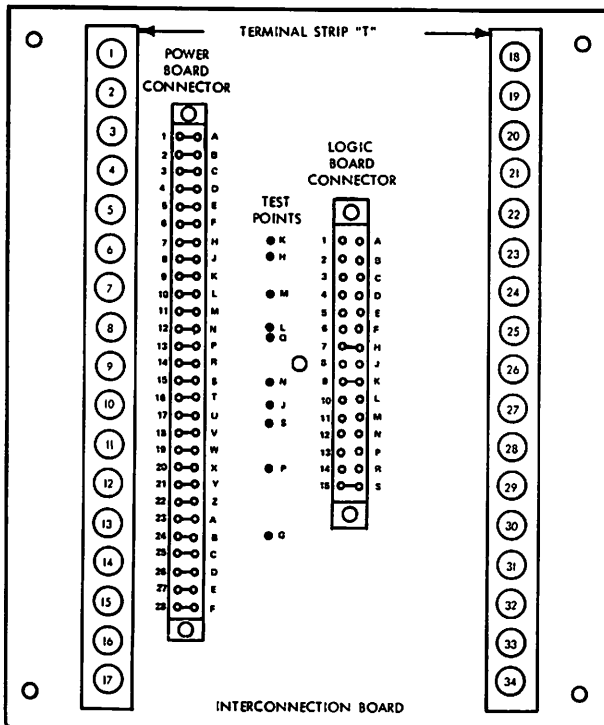

C. CHECK POWER BOARD:

- (1) If clutch power is correct, remove cover from control box.
- (2) Check power board using procedure given in Item 2, paragraph J, steps (2) through (23).

D. CHECK P.C. BOARD CONNECTORS:

- (1) If power board checks good, remove electrical power from equipment.
- (2) Check P.C. board connectors using procedure given in Item 2, paragraph K.
- (3) If P.C. board connectors check good, replace logic board. Refer to REPAIR PARTS LIST for replacement part number.

6. MACHINE STOPS BEFORE REACHING PRESELECTED POSITION ON GARMENT

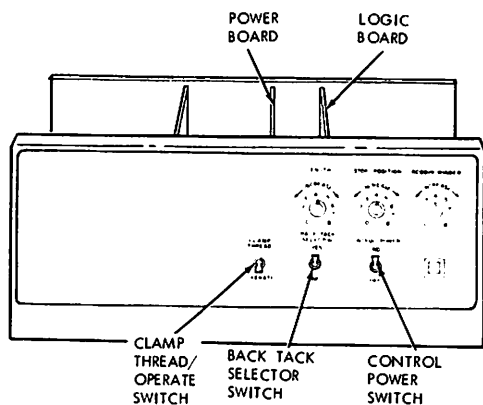
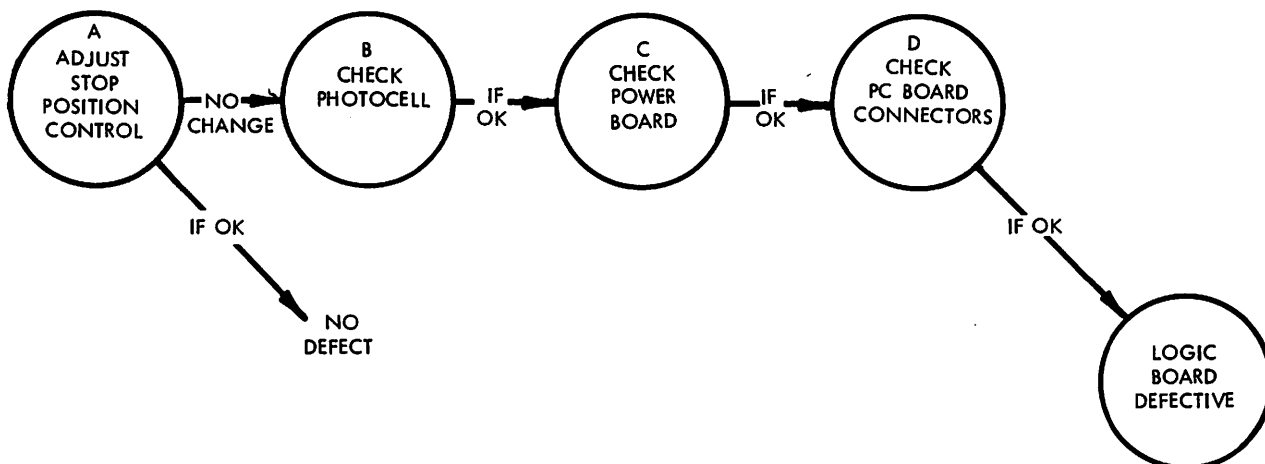

A. ADJUST STOP POSITION CONTROL:

(1) Adjust STOP POSITION control on control panel in INCREASE direction and check unit.

(2) If machine sews further after adjusting STOP POSITION control, continue adjusting until proper operation is achieved. If adjustment of STOP POSITION control can make machine sew to proper position on panel, machine has no defect.

B. CHECK PHOTOCELL SENSITIVITY:

(1) If adjusting STOP POSITION control does not improve machine operation, check position of sewing light. Sewing light should be aimed at sewing area and 8 to 9 inches above table top.

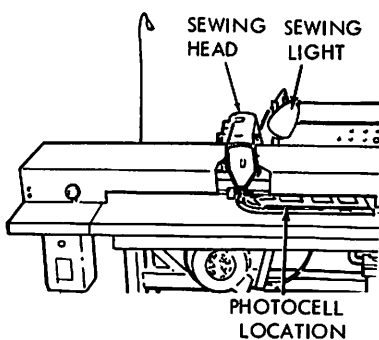

(2) If sewing light is properly positioned, check photocell sensitivity. Refer to Item 3, paragraph J, for photocell sensitivity test procedure.

ITEM NO. 6

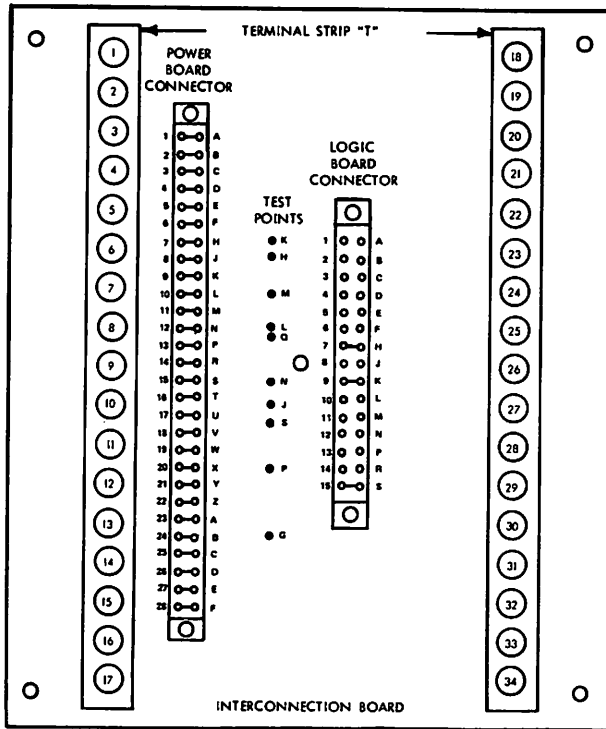

C. CHECK POWER BOARD:

- (1) If photocell sensitivity is correct, remove cover from control box.
- (2) Check power board using procedure given in Item 2, paragraph J, Steps (2) through (23).

D. CHECK P.C. BOARD CONNECTORS:

- (1) If power board checks good, remove electrical power from equipment.
- (2) Check P.C. board connectors using procedure given in Item 2, paragraph K.
- (3) If P.C. board connectors check good, replace logic board. Refer to REPAIR PARTS LIST for replacement part number.

7. MACHINE SEWS BEYOND PRESELECTED POSITION ON GARMENT.

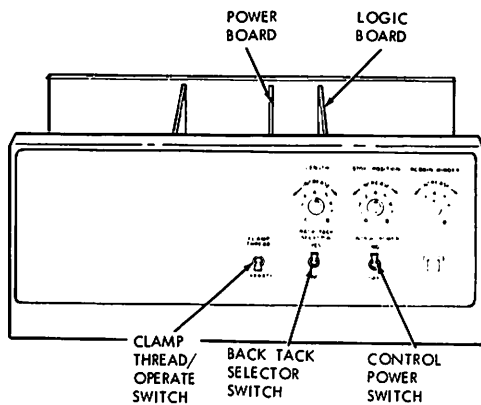
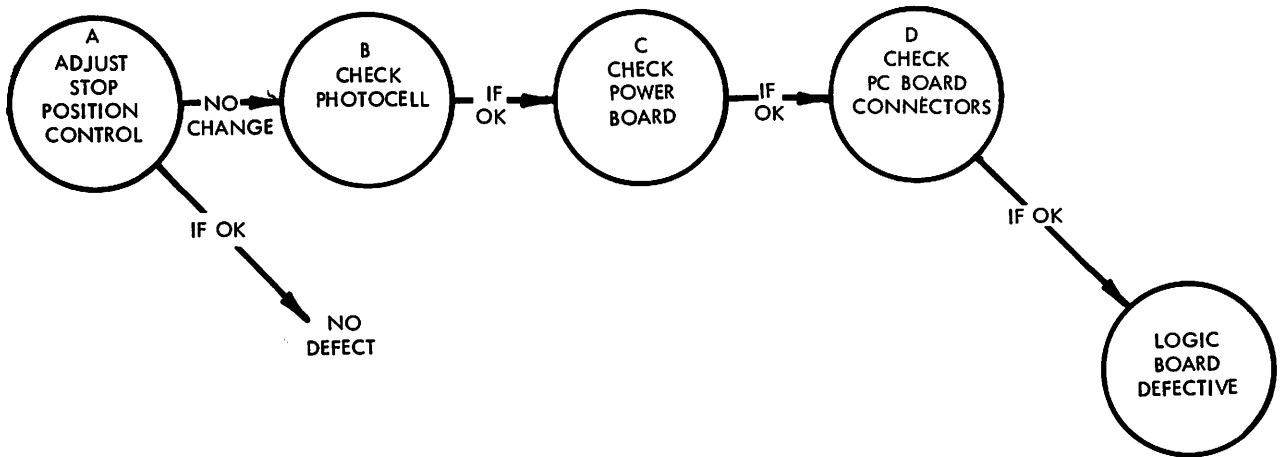

A. ADJUST STOP POSITION CONTROL:

- (1) Adjust STOP POSITION control on control panel in direction opposite to arrow and check unit.
- (2) If seam length is decreased after adjusting STOP POSITION control, repeat adjustment until proper seam length is achieved. If adjustment of STOP POSITION control make machine stop sewing at proper place, machine has no defect.

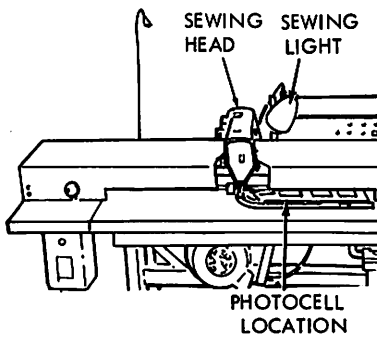

B. CHECK PHOTOCELL:

- (1) If adjusting STOP POSITION control does not correct seam length, check position of sewing light. Sewing light should be aimed at needle area and 8 to 9 inches above table top. Turn off CONTROL POWER switch and open control box. Remove logic board from control box. Get ohmmeter.

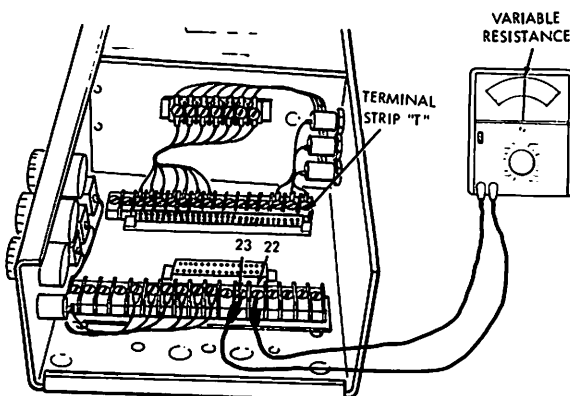

- (2) Connect an ohmmeter between terminals 22 and 23 on terminal strip "T" in control box.

ITEM NO. 7

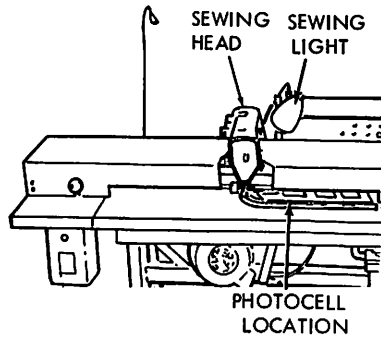

(3) Move clamp to expose photocell, then cover and uncover photocell while observing ohmmeter reading. Ohmmeter should show a higher resistance reading when photocell is covered than when it is uncovered.

(4) If ohmmeter reads infinity (open) photocell or harness is defective; if a resistance is read, but does not change photocell is defective.

(5) If photocell and harness check good check photocell sensitivity. Refer to Item 3, paragraph G, for photocell sensitivity adjustment.

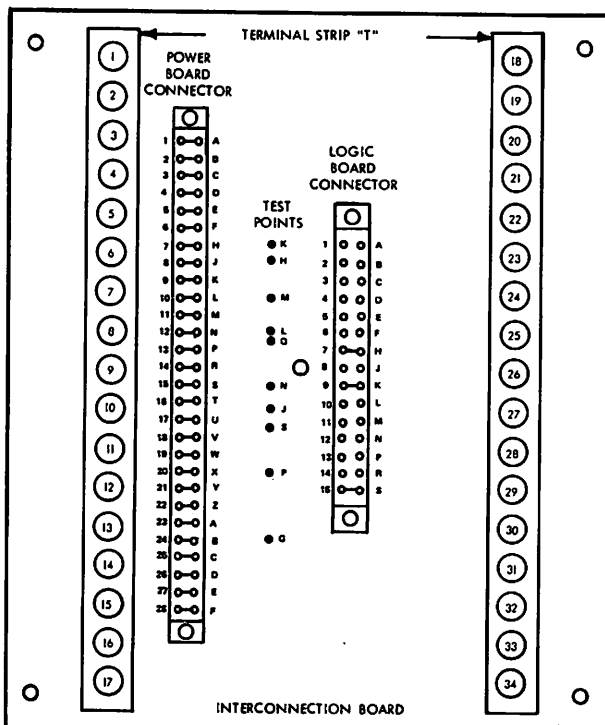

C. CHECK POWER BOARD:

(1) If photocell sensitivity adjustment is correct, remove cover from control box.

(2) Check power board using procedure given in Item 2, paragraph J, steps (2) through (23).

D. CHECK P.C. BOARD CONNECTORS:

(1) If power board checks good, remove electrical power from equipment.

(2) Check P.C. board connectors using procedure given in Item 2, paragraph K.

(3) If P.C. board connectors check good, replace logic board. Refer to REPAIR PARTS LIST for replacement part number.

8. MACHINE STARTS BEFORE CLAMP IS COMPLETELY DOWN.

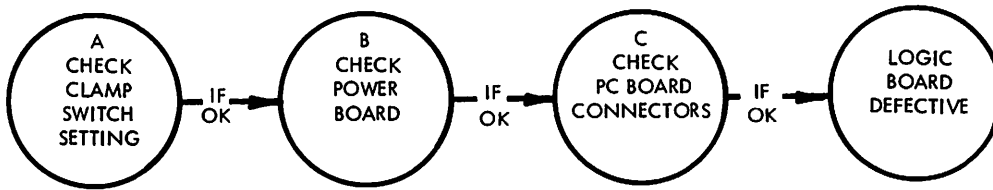

A. CHECK CLAMP SWITCH SETTING:

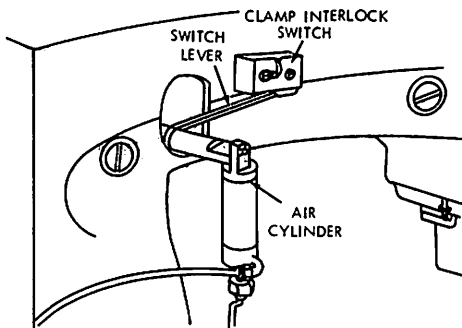

(1) Check clamp switch setting using procedure given in Item 3, paragraph E.

(2) Clamp switch should not open until clamp is in full down position. Adjust clamp if necessary.

B. CHECK POWER BOARD:

(1) If clamp switch setting is correct, remove cover from control box.

(2) Check power board using procedure given in Item 2, paragraph J, steps (2) through (23).

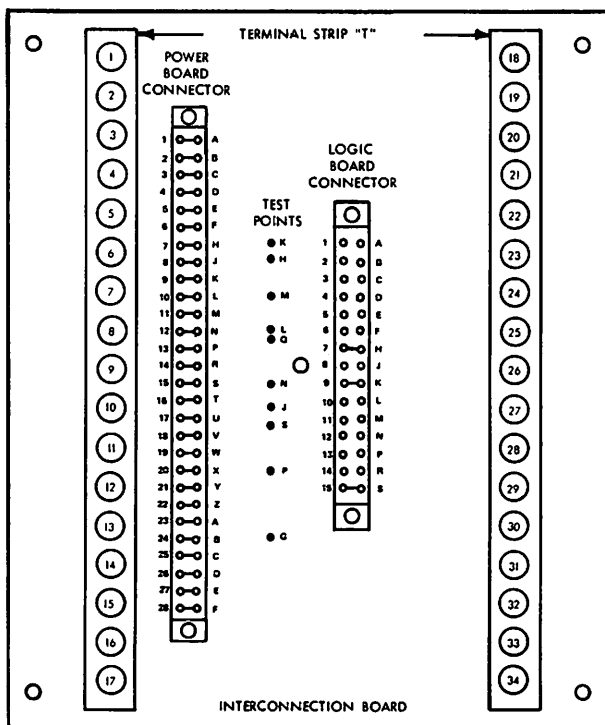

C. CHECK P.C. BOARD CONNECTORS:

(1) If power board checks good, disconnect power from equipment.

(2) Check P.C. board connectors using procedure given in Item 2, paragraph H.

(3) If P.C. board connectors check good, replace logic board. Refer to REPAIR PARTS LIST, for replacement part number.

8. MACHINE STARTS BEFORE CLAMP IS COMPLETELY DOWN.

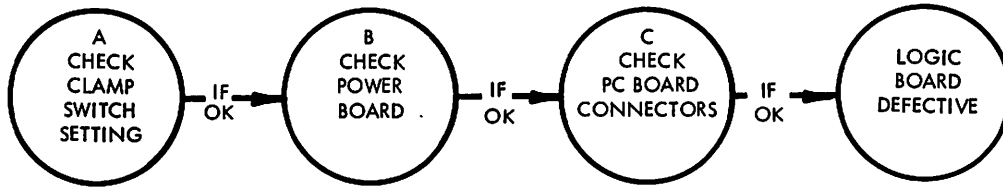

A. CHECK CLAMP SWITCH SETTING:

- (1) Check clamp switch setting using procedure given in Item 3, paragraph E.
- (2) Clamp switch should not open until clamp is in full down position. Adjust clamp if necessary.

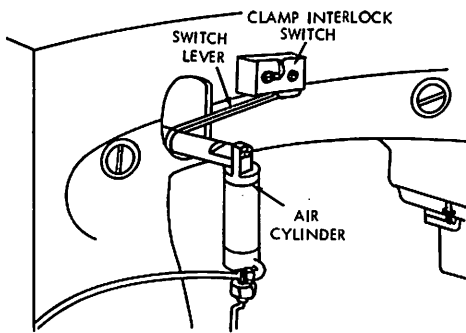

B. CHECK POWER BOARD:

- (1) If clamp switch setting is correct, remove cover from control box.
- (2) Check power board using procedure given in Item 2, paragraph J, steps (2) through (23).

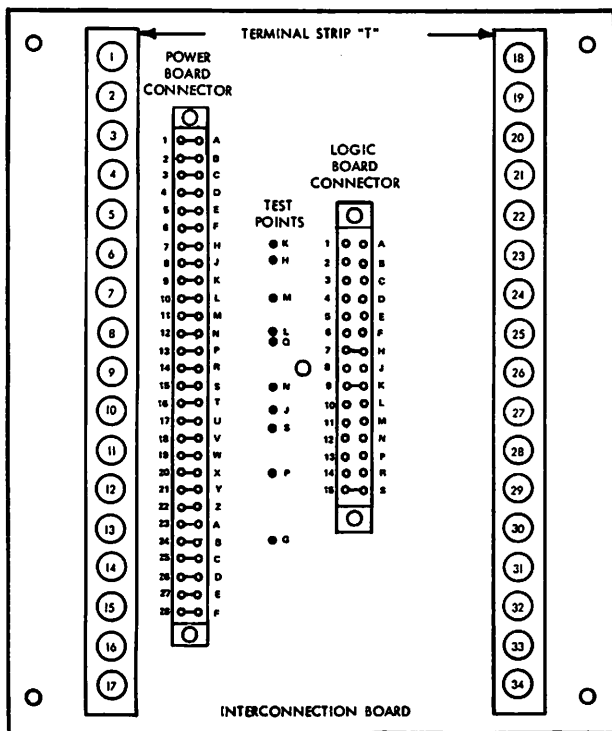

C. CHECK P.C. BOARD CONNECTORS:

- (1) If power board checks good, disconnect power from equipment.
- (2) Check P.C. board connectors using procedure given in Item 2, paragraph K.
- (3) If P.C. board connectors check good, replace logic board. Refer to REPAIR PARTS LIST, for replacement part number.

9. VISION PLATE WILL NOT OPERATE.

ITEM NO. 9

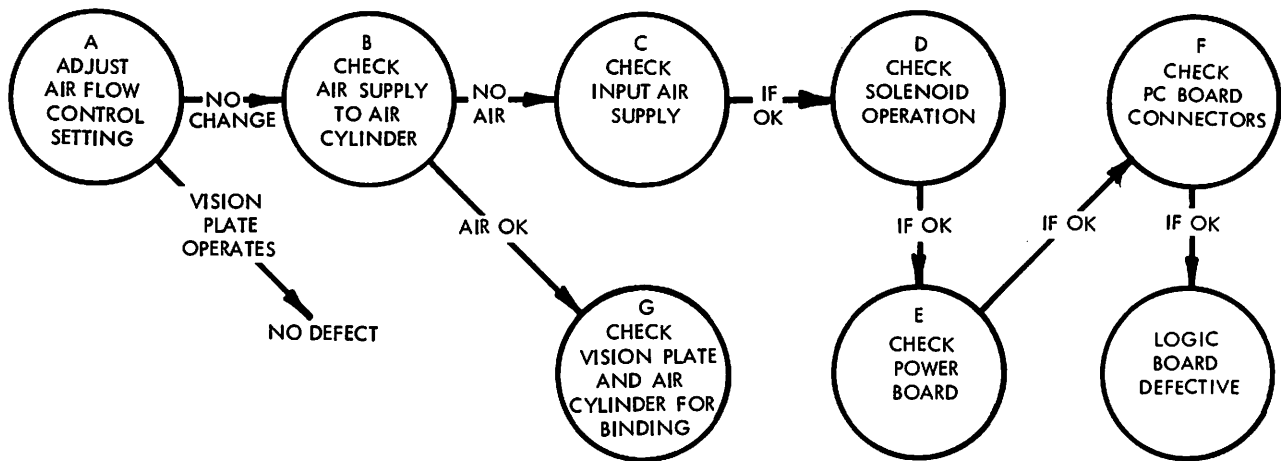

A. ADJUST AIR FLOW CONTROL SETTING:

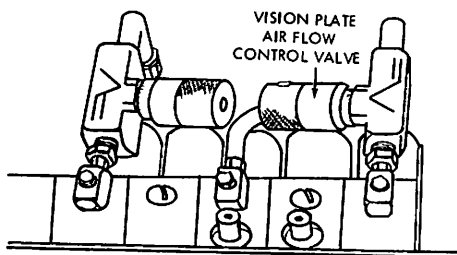

(1) Remove top cover from control box and turn vision plate air flow control valve counter-clockwise.

(2) If vision plate now operates, adjust air flow control valve so that vision plate closes just before clamp reaches full down position. If adjustment of air flow control valve corrects vision plate operation, no further repairs are needed.

B. CHECK AIR SUPPLY TO AIR CYLINDER:

(1) If adjustment of air flow control valve does not cause vision plate to operate, remove air line at outlet side of vision plate air flow control valve.

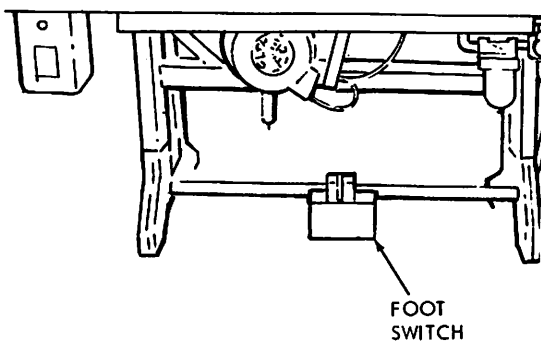

(2) Operate foot switch to first step while observing valve air outlet fitting. Air should be released from valve outlet when foot switch is operated.

(3) If no air is released from valve, check air line from solenoid to valve for breaks and kinks.

(4) If air supply is present at valve, go to paragraph G.

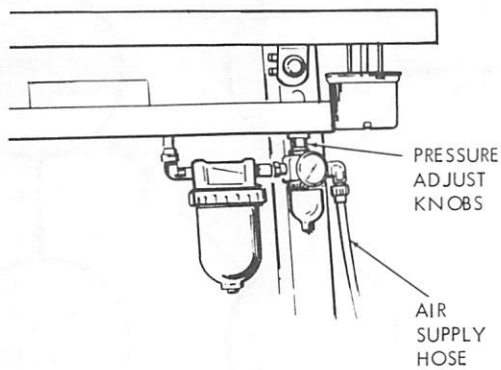

C. CHECK INPUT AIR SUPPLY:

- (1) If no air is present at vision plate air flow control valve, check input air supply.
- (2) Input air pressure should be between 40 and 45 psig. If air pressure setting is incorrect adjust air pressure regulator and check vision plate operation.

D. CHECK SOLENOID OPERATION:

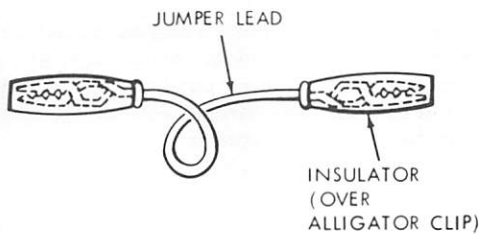

- (1) If air supply is present at system inlet, get an 18-inch jumper with insulated alligator clips on both ends.
- (2) Connect jumper lead from test point G on interconnection board to terminal 11 of terminal strip "T". Air should be released from airflow control valve fitting when jumper lead is connected.

(3) If solenoid does not operate, releasing air from airflow control valve when jumper lead is connected, solenoid is defective. Refer to REPAIR PARTS LIST for replacement part number.

(4) Remove jumper lead.

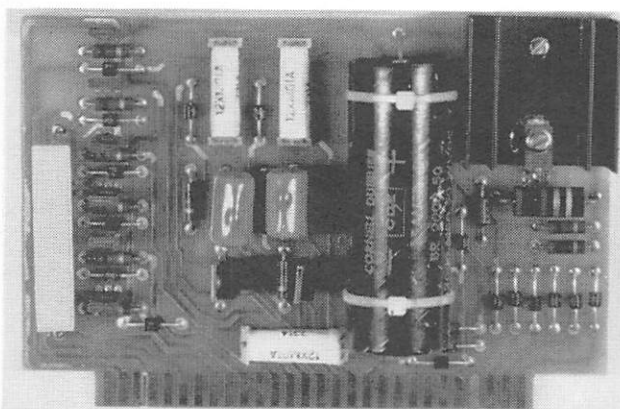

E. CHECK POWER BOARD:

- (1) If vision plate solenoid checks good, check power board.
- (2) Refer to Item 2, paragraph J, steps (2) through (23) for power board test procedure.

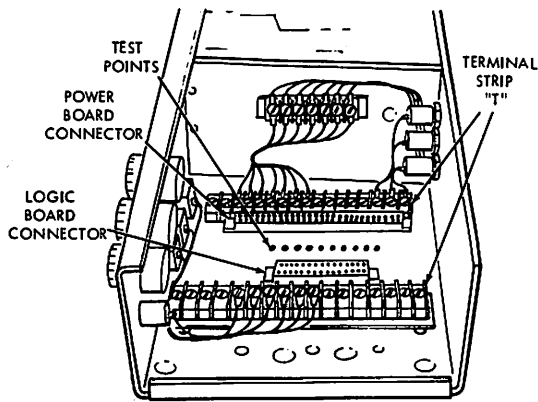

F. CHECK P.C. BOARD CONNECTORS:

- (1) If power board checks good, disconnect electrical power from equipment.
- (2) Check P.C. Board connectors using procedure given in Item 2, paragraph K. If P.C. board connectors check good, logic board is defective. Refer to REPAIR PARTS LIST for replacement part number.

G. CHECK VISION PLATE AND AIR CYLINDER FOR MECHANICAL BINDING:

- (1) If air supply to vision plate air cylinder checks good, remove air line at outlet side of vision plate air flow control valve.

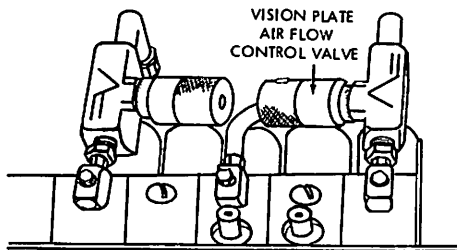

- (2) Actuate vision plate by hand. With air line removed from air flow control valve, vision plate and air cylinder arm should move freely with no binding.

- (3) Replace air line on air flow control valve.

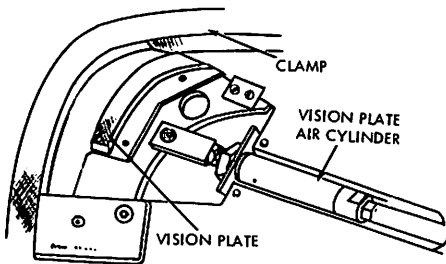

10. MACHINE WILL NOT FAST SEW

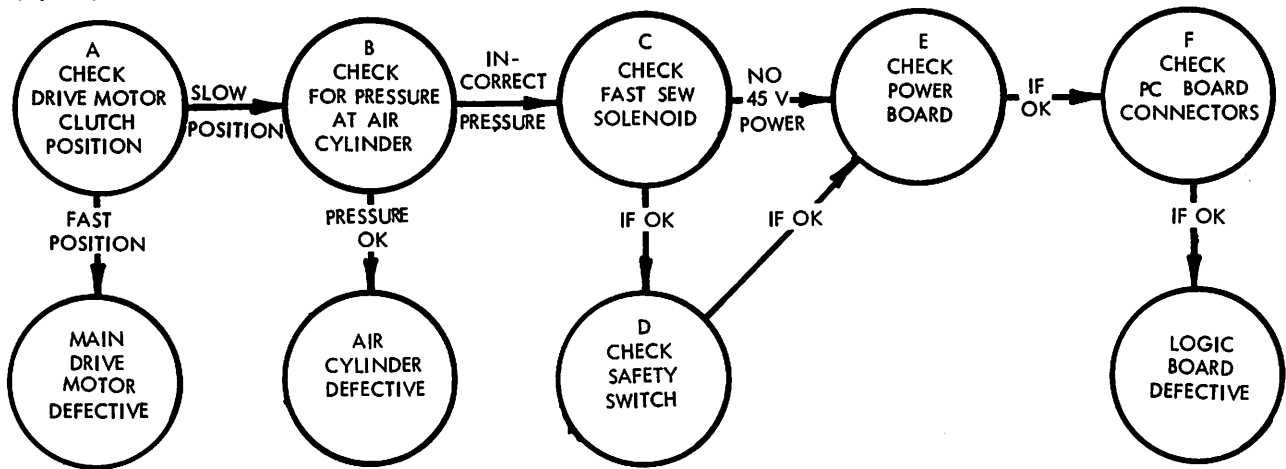

A. CHECK DRIVE MOTOR CLUTCH POSITION:

(1) Visually check position of drive motor clutch arm. Arm should be in its extended or fast position after selected number of slow stitches have been completed.

(2) If clutch arm operates properly main drive motor clutch assembly is defective. Refer to drive motor instruction manual for motor repair or replacement instructions.

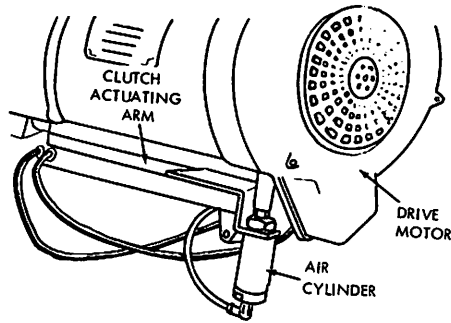

B. CHECK FOR PRESSURE AT AIR CYLINDER:

(1) If drive motor clutch arm is in its retracted position, and does not change during machine operation, remove air hose from air cylinder on clutch arm, and operate unit. Air pressure should be off at beginning of cycle, then come on after selected number of slow stitches have been completed.

(2) If air pressure operates properly at air cylinder hose, air cylinder is defective. Repair or replace air cylinder and recheck unit. Refer to REPAIR PARTS LIST for replacement part number.

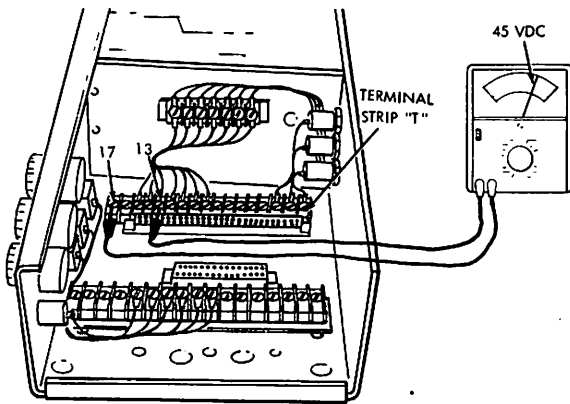

C. CHECK FAST SEW SOLENOID:

(1) If no air pressure is present at motor clutch air cylinder hose, remove cover from control box. Get a DC voltmeter capable of reading 45 volts.

(2) Connect voltmeter positive (+) probe to terminal 13 of terminal strip "T" and connect negative (-) probe to terminal 17. Voltmeter should read 45 volts DC. If voltmeter does not read 45 volts DC, go to paragraph E.

(3) If voltmeter reads 45 volts DC, connect air hose back to air cylinder and disconnect hose from fast sew solenoid. Set CLAMP switch to THREAD position and make sure clamp goes to lowered position. Get a jumper lead with insulated alligator clips on each end.

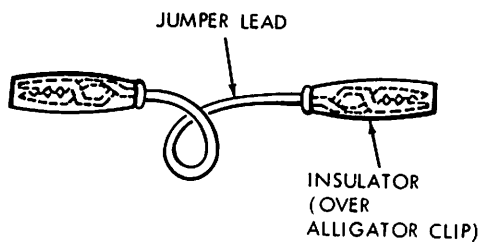

(4) Connect one end of jumper lead to terminal 13 on terminal strip "T" and connect other end to terminal 17. Fast sew solenoid should operate, and air should flow from solenoid outlet port.

(5) If fast sew solenoid does not operate when jumper lead is installed, solenoid is defective. Refer to REPAIR PARTS LIST for replacement part number.

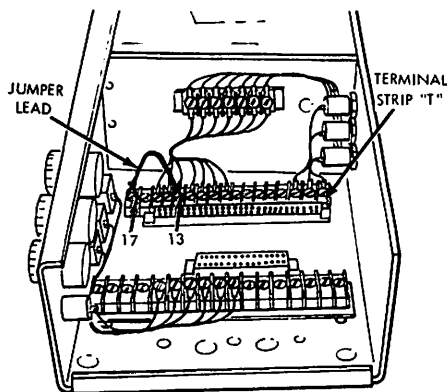

D. CHECK SAFETY SWITCH:

(1) If fast sew solenoid checks good, connect jumper lead between terminals 13 and 16 on terminal strip "T".

(2) If fast sew solenoid operates, go to paragraph E. If fast sew solenoid does not operate, safety switch is defective.

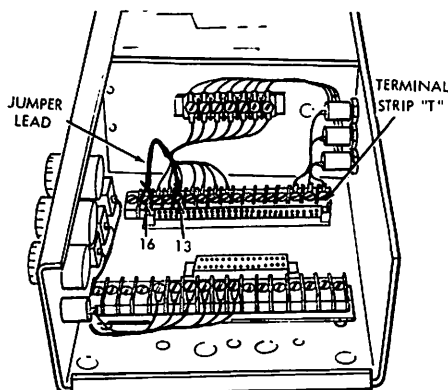

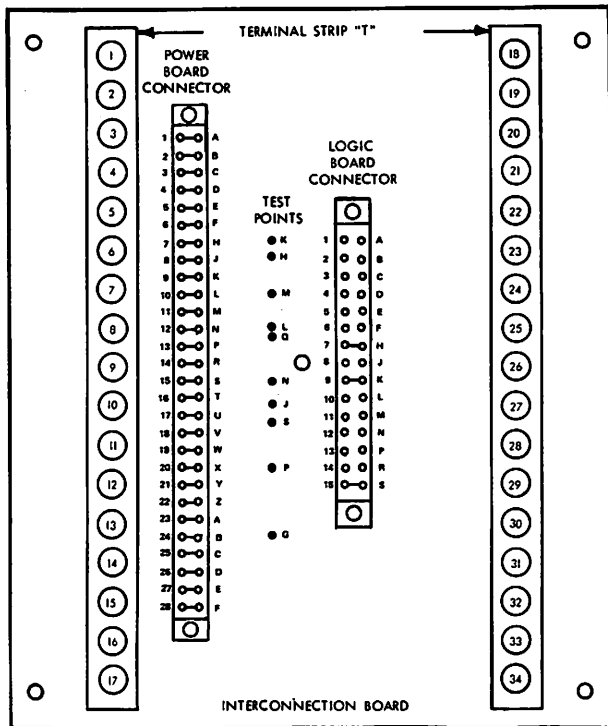

E. CHECK POWER BOARD:

- (1) If safety switch checks good, remove jumper lead.
- (2) Check power board using procedure given in Item 2, paragraph J, steps (2) through (23).

F. CHECK P.C. BOARD CONNECTORS:

- (1) If power board checks good, remove electrical power from equipment.
- (2) Check P.C. board connector using procedure given in Item 2, paragraph K.
- (3) If P.C. board connectors check good, replace logic board.

11. CLAMP WILL NOT RETURN TO HOME POSITION

ITEM NO. 11

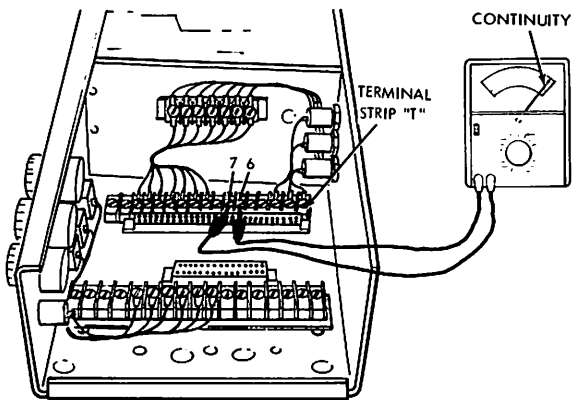
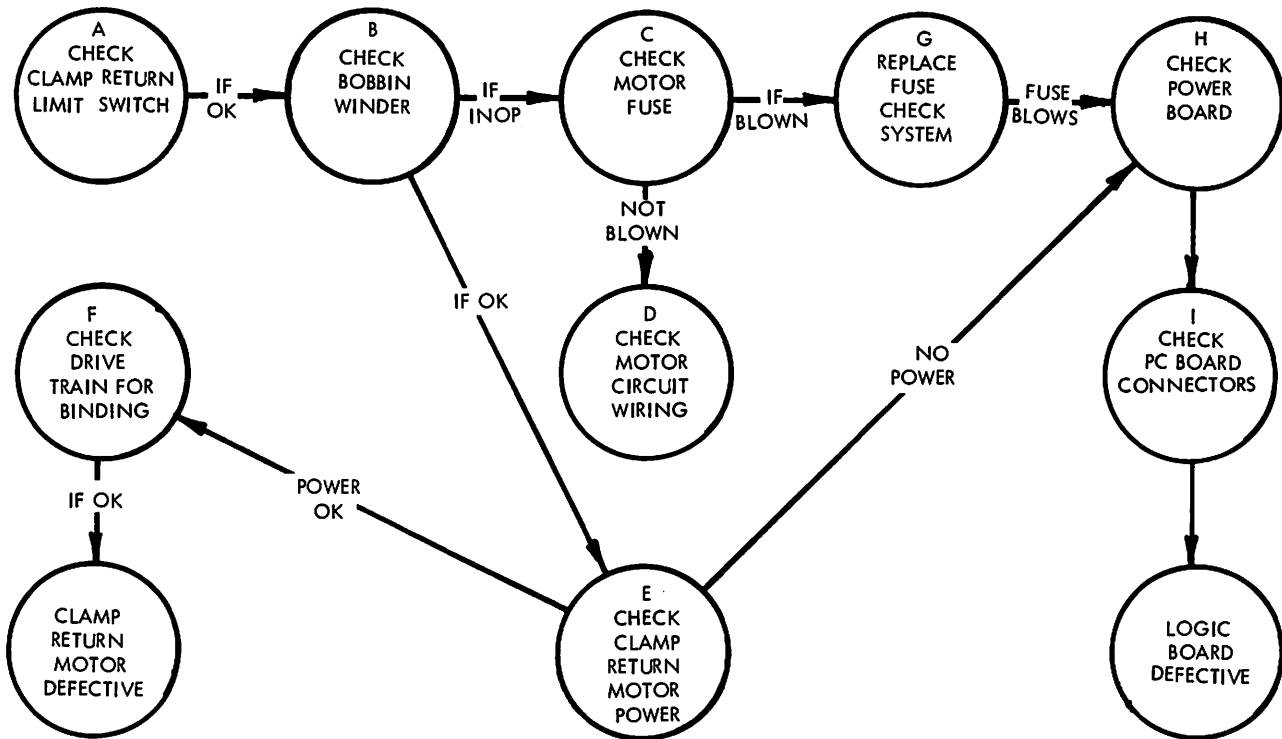

A. CHECK CLAMP RETURN LIMIT SWITCH:

(1) Set CONTROL POWER switch to OFF position. Get ohmmeter or other continuity checking device. Remove cover from control box.

(2) Connect ohmmeter across clamp return limit switch terminals (terminals 6 and 7 on terminal strip "T").

(3) With switch in unactuated position, (clamp not in home position) ohmmeter should read continuity.

(4) Manually actuate clamp return limit switch while observing ohmmeter reading. Ohmmeter reading should go from continuity to open when switch is actuated; if not, remove clamp return limit switch and replace with a new item. Refer to REPAIR PARTS LIST for replacement part number.

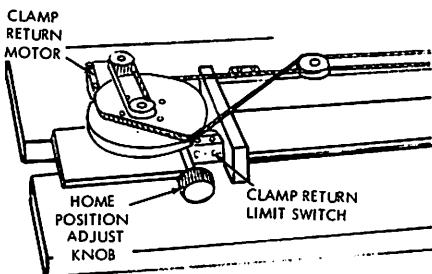

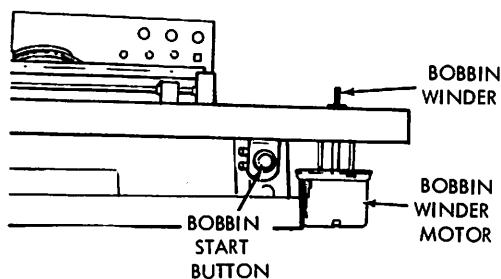

B. CHECK BOBBIN WINDER:

(1) If clamp return limit switch checks good, set CONTROL POWER switch to ON position and press bobbin winder start button. Bobbin winder motor should run.

(2) If bobbin winder motor runs after start button is pressed, go to paragraph E.

C. CHECK MOTOR FUSE:

(1) If bobbin winder motor is found to be inoperative, check fuse "FM".

(2) If fuse "FM" is blown, go to paragraph G.

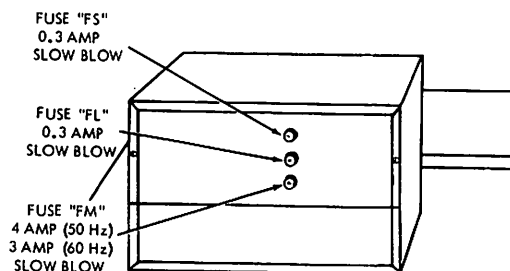

D. CHECK MOTOR CIRCUIT WIRING:

(1) If both motors are inoperative and fuse is not blown, turn power off. Get an ohmmeter. Remove control box cover.

(2) Check continuity of wiring common to both motors as follows:

- a. Check continuity of black lead from fuse "FM" to clamp return motor.
- b. Check continuity of lead from output side of CONTROL POWER switch to terminal 12 on terminal strip "T".

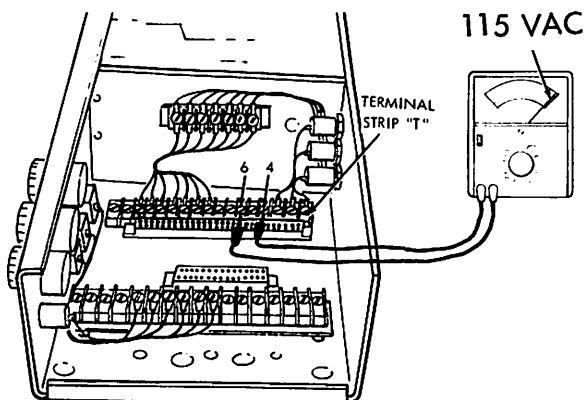
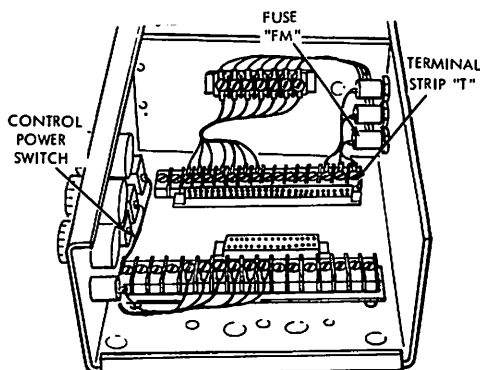

E. CHECK CLAMP RETURN MOTOR POWER:

(1) If bobbin winder checks good, remove cover from control box. Get AC voltmeter capable of reading in 115 volt range.

(2) Set CONTROL POWER switch to ON position. Operate unit; connect meter across terminals 4 and 6 on terminal board "T" while carriage is at its extreme left position. Voltmeter should read 115 volts AC.

(3) If voltmeter reads zero, go to paragraph H.

F. CHECK DRIVE TRAIN FOR BINDING:

(1) If clamp return motor power checks good, remove cover from left side of clamp carriage mechanism.

(2) Loosen two set screws on clamp return motor drive pulley and remove pulley from motor.

(3) Apply power to equipment and check clamp return motor with drive pulley disconnected.

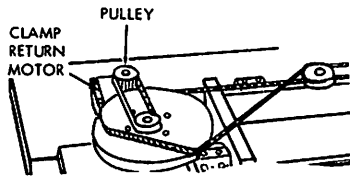

(4) If clamp return motor does not run when disconnected from machine, clamp return motor is defective. Refer to REPAIR PARTS LIST for replacement part number.

(5) If motor runs when disconnected from machine, remove other cover from clamp carriage mechanism and check carriage for binding. Clamp carriage should move freely in both directions.

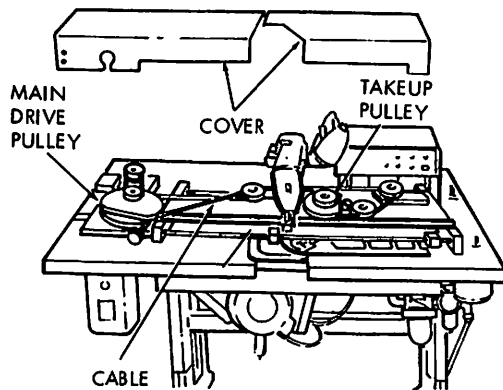

(6) If clamp carriage does not move freely, adjust mechanical HOME position control knob as necessary to remove tension from clamp carriage drive cable, then disconnect cable by lifting pin from opening in pulley. Check clamp carriage mechanism. If carriage still does not move freely, disassemble carriage and correct binding condition.

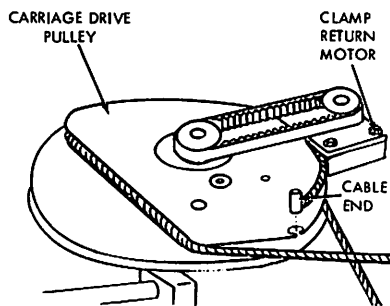

(7) If clamp carriage is not binding, rotate clamp drive pulley manually. Pulley should rotate freely; if not, check electric clutch to ensure that clutch is fully disengaged. If clutch is not disengaged, refer to adjustment procedures and check clutch adjustment.

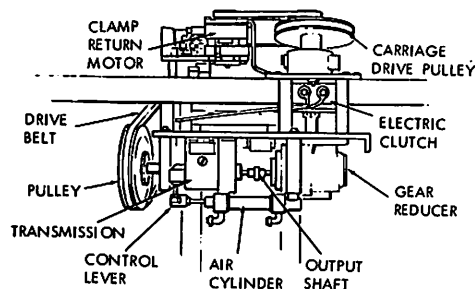

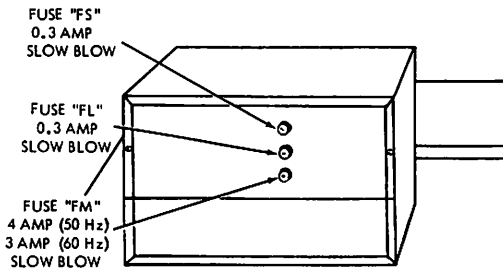

G. REPLACE FUSE, CHECK SYSTEM:

- (1) If fuse "FM" is found to be blown, replace fuse and recheck system.
- (2) If equipment operates properly after fuse is replaced, operate through several cycles to ensure that fuse does not blow.
- (3) If equipment operates properly and fuse does not blow when clamp return motor operates, operate bobbin winder. If fuse blows when bobbin winder starts, go to Item 16.

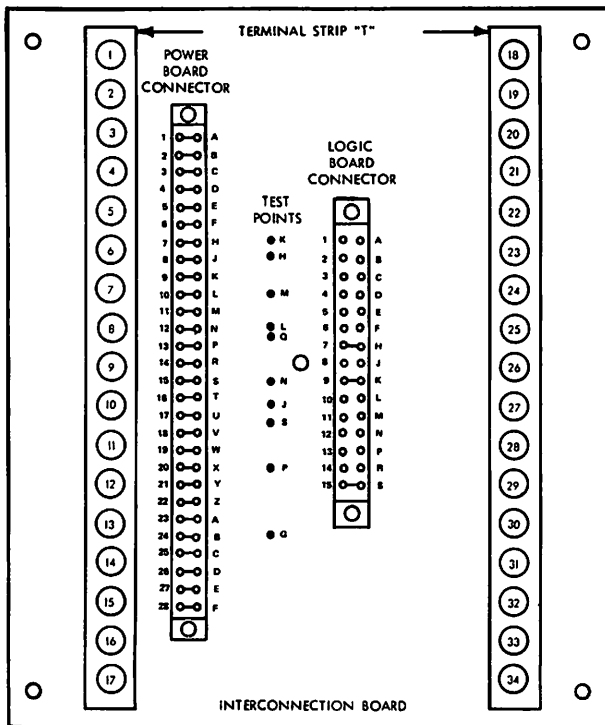

H. CHECK POWER BOARD:

- (1) If fuse blows again after replacement, or if there is no power to clamp return motor while bobbin winder is OK, remove cover from control box.
- (2) Check power board using procedure given in Item 2, paragraph J, steps (2) through (23).

I. CHECK P.C. BOARD CONNECTORS:

- (1) If power board checks good, disconnect electrical power from equipment.
- (2) Check P.C. board connectors using procedure given in Item 2, paragraph K.
- (3) If P.C. board connectors check good, replace logic board. Refer to REPAIR PARTS LIST for replacement part number.

12. CLAMP RETURNS TOO SLOWLY

ITEM NO. 12

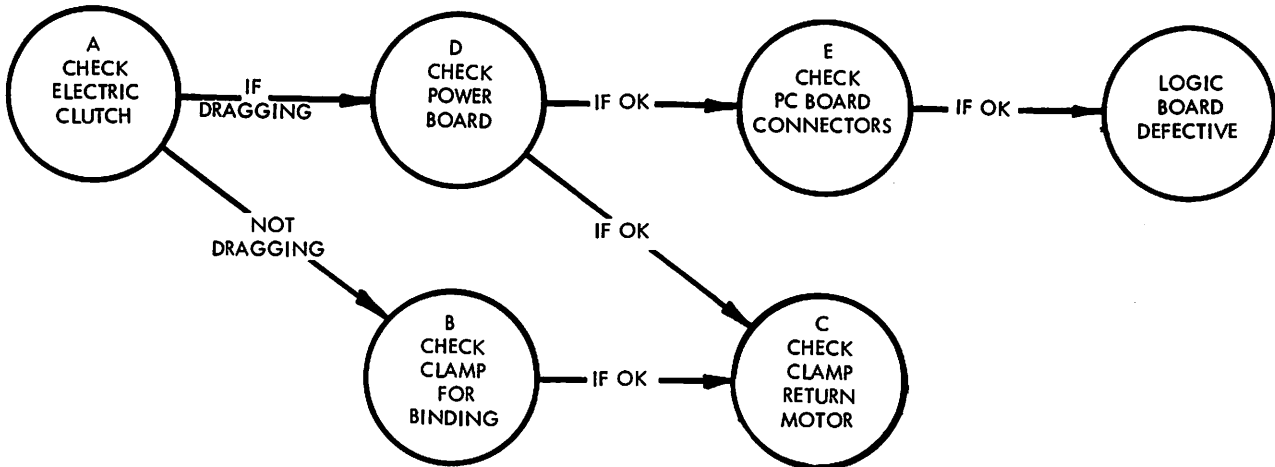

A. CHECK ELECTRIC CLUTCH:

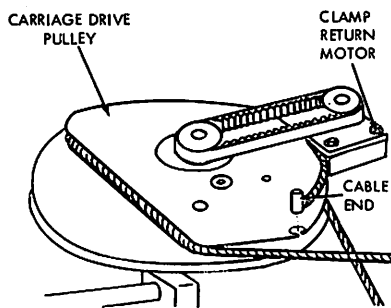

(1) Remove cover from left end of clamp carriage and disconnect clamp carriage drive cable by lifting pin out of slot in drive pulley.

(2) Loosen two set screws in clamp return motor drive pulley and remove pulley from motor.

(3) Turn on CONTROL POWER switch.

(4) Rotate clamp drive pulley in both directions by hand. There should be very little drag on pulley.

(5) If there is excessive drag on pulley, turn off CONTROL POWER switch and rotate clamp drive pulley. If still dragging, electric clutch is defective.

(6) If pulley stops dragging when switch is turned off, go to paragraph D.

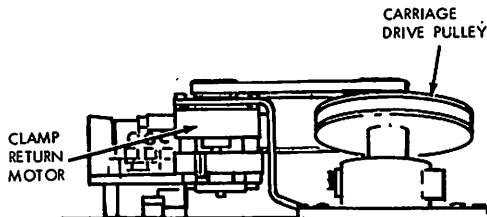

B. CHECK CLAMP FOR BINDING:

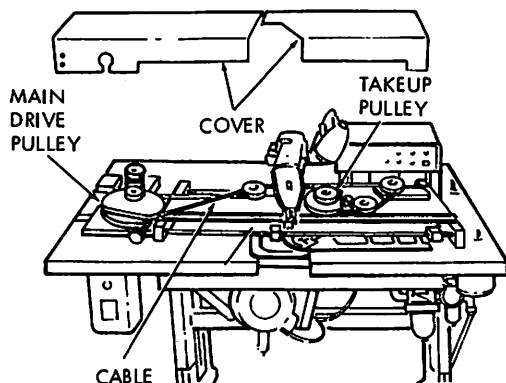

(1) If clutch is not dragging, move clamp carriage in both directions with cable disconnected from clamp drive pulley. Clamp carriage should move freely in both directions. If clamp operates freely, leave cable disconnected, and go to paragraph C.

(2) If clamp does not move freely, disassemble clamp carriage mechanism and correct binding condition.

C. CHECK CLAMP RETURN MOTOR:

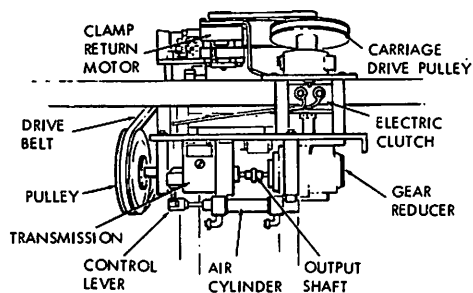

(1) If clamp carriage operates freely, set CONTROL POWER switch to OFF position.

(2) Rotate clamp drive pulley away from home position, then set CONTROL POWER switch to ON position.

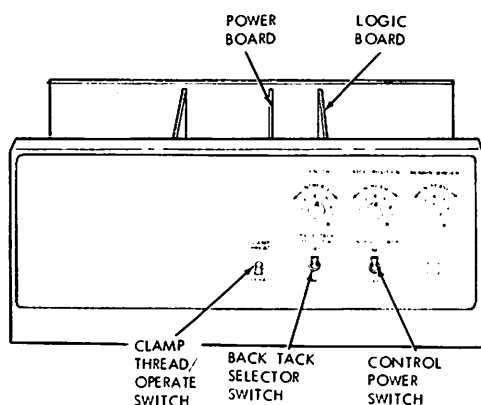

(3) If clamp motor runs slowly with clamp drive cable disconnected, set CONTROL POWER switch to OFF position and rotate motor shaft by hand. If shaft turns hard, check motor pulley to ensure that pulley does not rub on motor housing. Check timing belt for proper tension, and check two timing pulleys to ensure that they are properly tightened on their respective shafts.

(4) If motor runs slowly with clamp drive cable disconnected, and no mechanical binding is observed in motor drive mechanism, clamp return motor is defective. Refer to REPAIR PARTS LIST for replacement part number.

(5) If motor runs properly with clamp drive cable disconnected, clamp carriage mechanism is binding.

D. CHECK POWER BOARD:

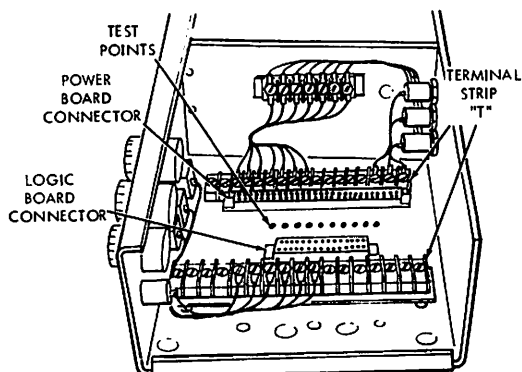

(1) If electric clutch is dragging, or if clamp return motor checks good, remove cover from control box.

(2) Check power board using procedure given in Item 2, paragraph J, steps (2) through (23).

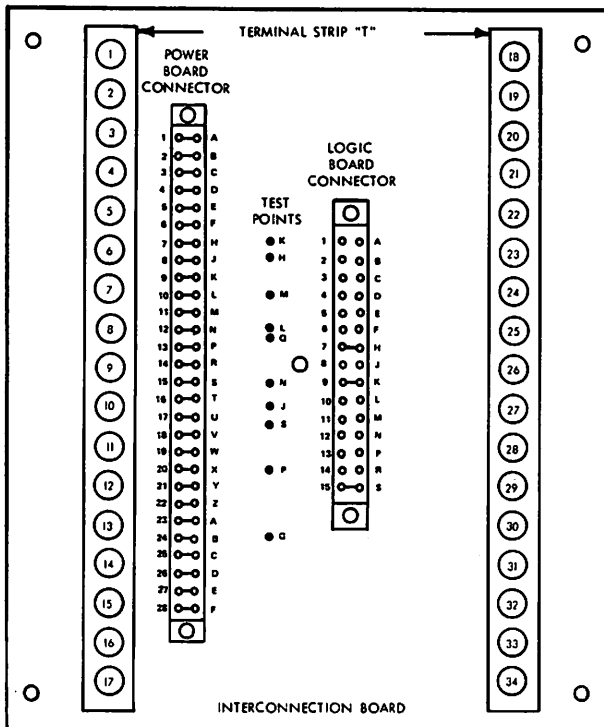

E. CHECK P.C. BOARD CONNECTORS:

- (1) If power board checks good, remove electrical power from equipment.
- (2) Check P.C. board connectors using procedure given in Item 2, paragraph K.
- (3) If P.C. board connectors check good, replace logic board. Refer to REPAIR PARTS LIST for replacement part number.

13. MACHINE SEWS ONLY WHEN FOOT SWITCH IS ENGAGED

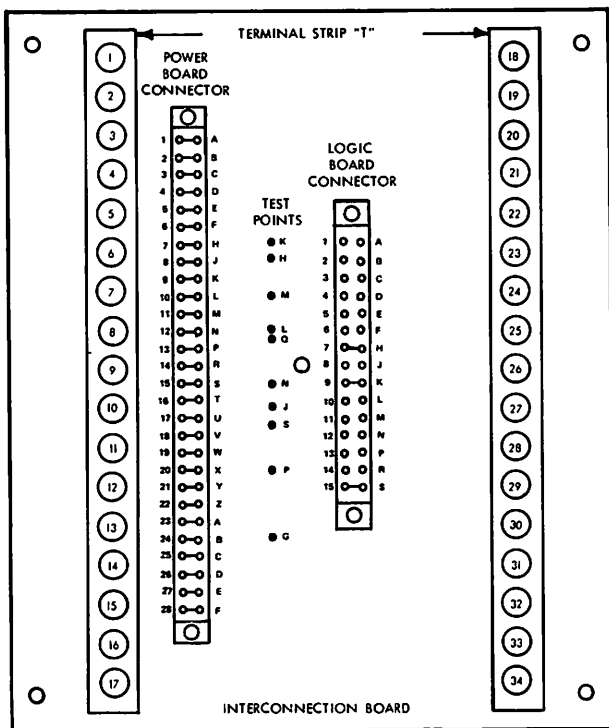
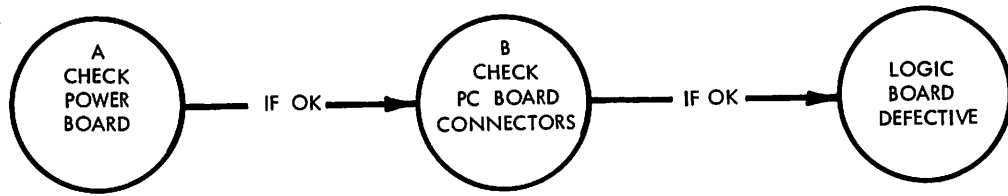

A. CHECK POWER BOARD:

- (1) Remove cover from control box.
- (2) Check power board using procedure given in Item 2, paragraph J, steps (2) through (23).

B. CHECK P.C. BOARD CONNECTORS:

- (1) If power board checks good, remove electrical power from equipment.
- (2) Check P.C. board connectors using procedure given in Item 2, paragraph K.
- (3) If P.C. board connectors check good, replace logic board. Refer to REPAIR PARTS LIST for replacement part number.

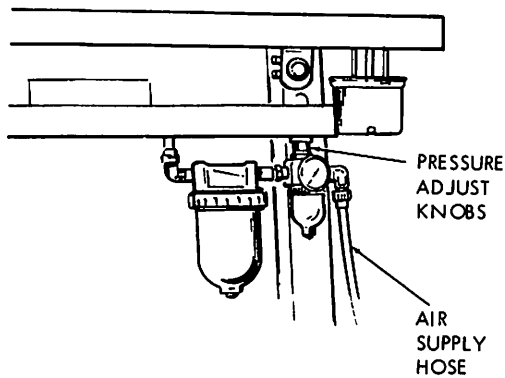
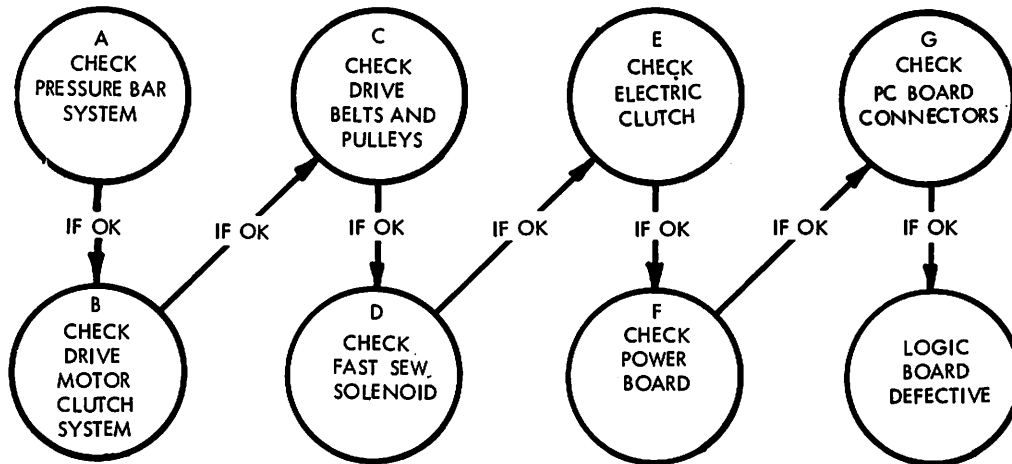

A. CHECK PRESSER BAR SYSTEM ON SEWING HEAD:

- (1) Check to see sufficient pressure applied to presser spring on sewing head.
- (2) Check for binds in presser bar mechanism.
- (3) Check to see clamp block fully contacts clamp plate surface when clamp in down position.

B. CHECK DRIVE MOTOR/CLUTCH SYSTEM:

- (1) Check drive motor and clutch system.
- (2) Refer to drive motor instruction manual for motor and clutch test procedure.

14. STITCH LENGTH VARIES

ITEM NO. 14

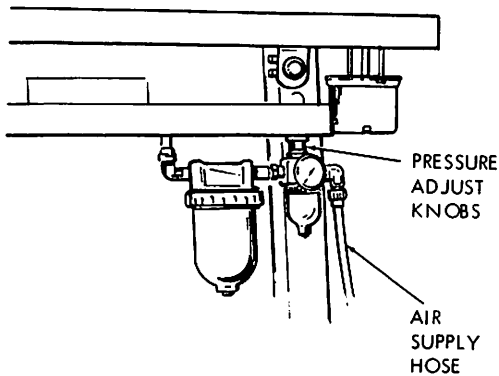
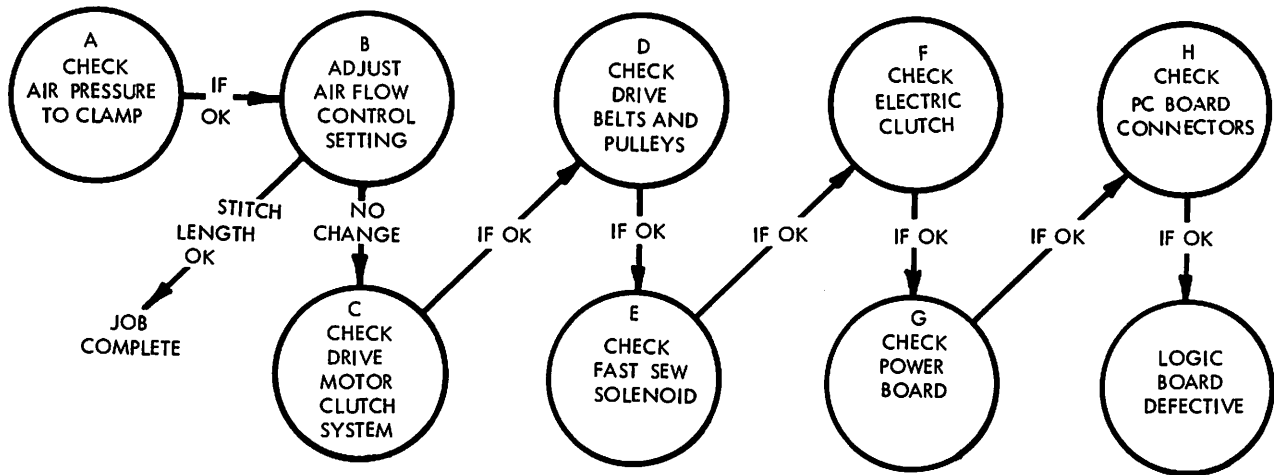

A. CHECK AIR PRESSURE TO CLAMP:

- (1) Check main air supply gage at approximately 45 psig.
- (2) Check air lines from main air supply to clamp and presser bar solenoid "C".
- (3) Check for leakage in valves.

B. ADJUST AIR FLOW CONTROL SETTINGS:

- (1) If air pressure and air lines are good, adjust clamp and pressure bar air flow control valves to obtain proper clamp hold-down pressure.
- (2) Check system. If stitch is OK after air flow adjustment, no further maintenance is required.

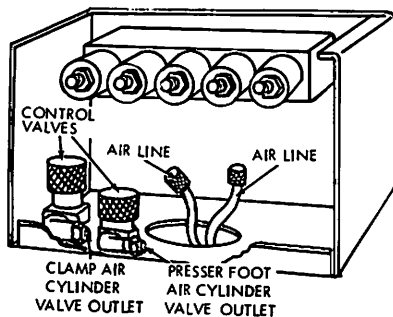

C. CHECK DRIVE MOTOR/CLUTCH SYSTEM:

- (1) If airflow adjustment does not correct stitch length variation, check drive motor and clutch system.
- (2) Refer to drive motor instruction manual for motor and clutch test procedure.

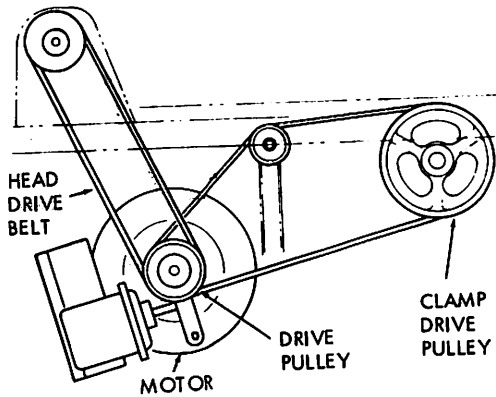

D. CHECK DRIVE TRAIN:

(1) If drive motor and clutch system checks good, check all drive belts and pulleys for jams and binding.

(2) Check transmission and speed reducing gear box for slipping, sticking or binding.

E. CHECK FAST SEW SOLENOID:

(1) If drive belts and pulleys are found to be OK, check fast sew solenoid for intermittent operation.

(2) Refer to Item 10, paragraph C for solenoid test procedure.

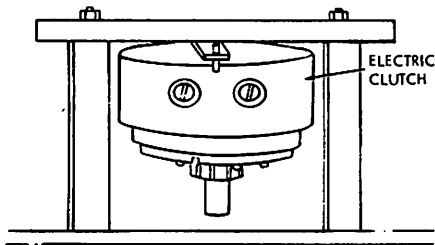

F. CHECK ELECTRIC CLUTCH:

(1) If fast sew solenoid checks good, check electric clutch operation.

(2) Refer to Item 4, paragraph L. for electric clutch test procedure.

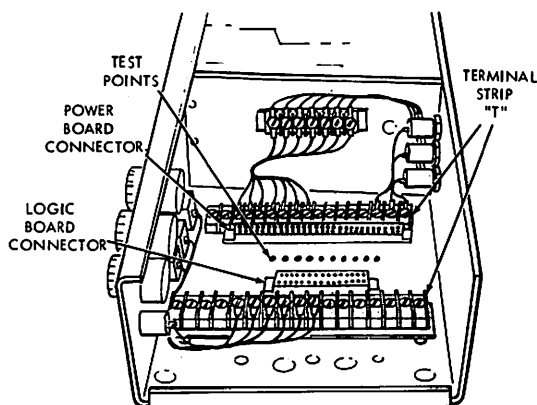

G. CHECK POWER BOARD:

(1) If electric clutch checks good, remove cover from control box.

(2) Check power board using procedure given in Item 2, paragraph J, Steps (2) through (23).

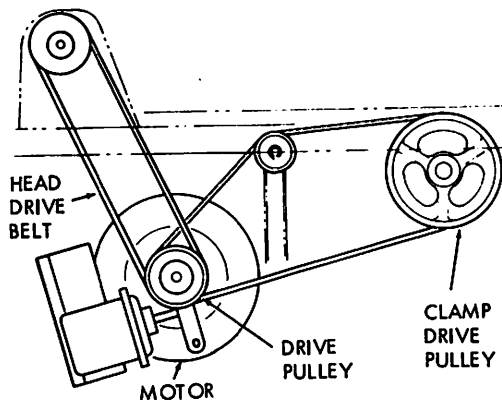

C. CHECK DRIVE TRAIN:

- (1) If drive motor and clutch system checks good, check all drive belts and pulleys for jams and binding.
- (2) Check transmission and speed reducing gear box for slipping, sticking or binding.

D. CHECK FAST SEW SOLENOID:

- (1) If drive belts and pulleys are found to be OK, check fast sew solenoid for intermittent operation.
- (2) Refer to Item 10, paragraph C for solenoid test procedure.

E. CHECK ELECTRIC CLUTCH:

- (1) If fast sew solenoid checks good, check electric clutch operation.
- (2) Refer to Item 4, paragraph M for electric clutch test procedure.

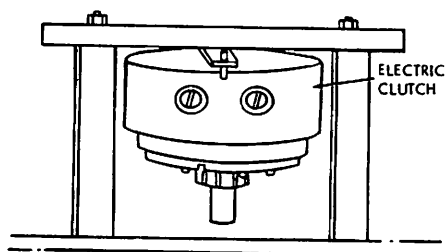

F. CHECK POWER BOARD:

- (1) If electric clutch checks good, remove cover from control box.
- (2) Check power board using procedure given in Item 2, paragraph J, Steps (2) through (23).

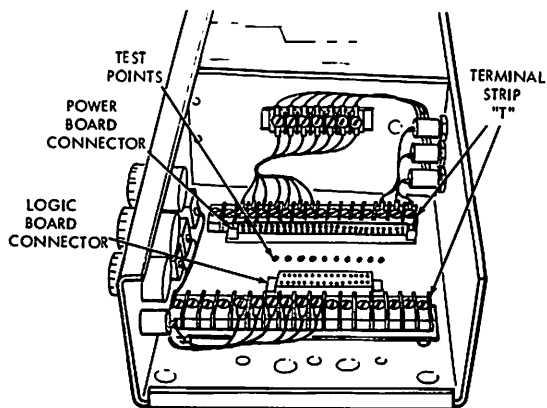

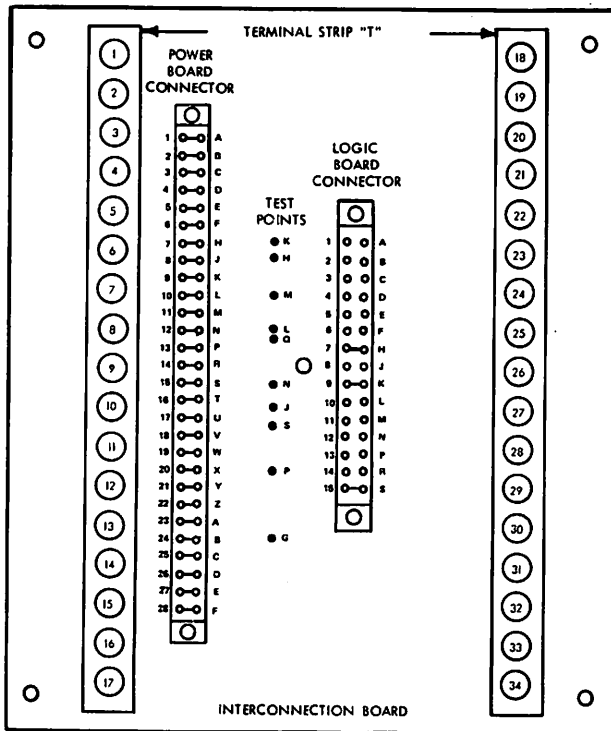

G. CHECK P.C. BOARD CONNECTORS:

- (1) If power board checks good, remove electrical power from equipment.
- (2) Check P.C. board connectors using procedure given in Item 2, paragraph K.
- (3) If P.C. board connectors check good, replace logic board. Refer to REPAIR PARTS LIST for replacement part number.

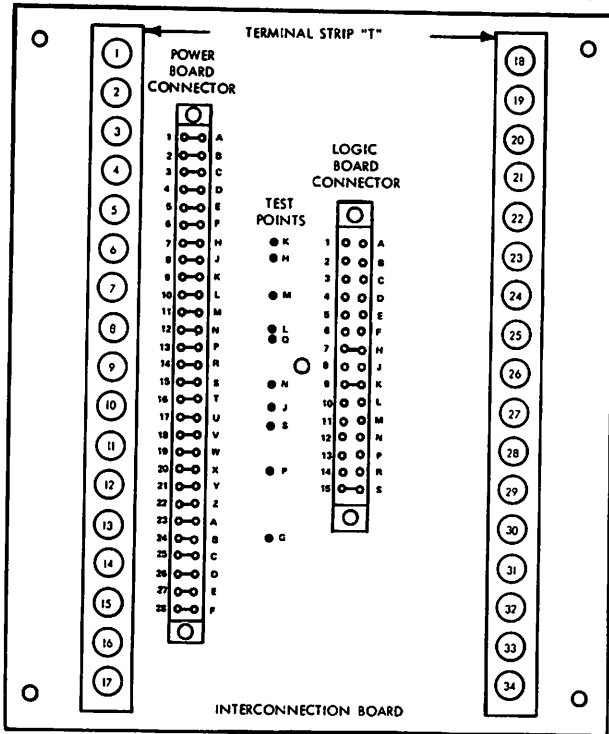

H. CHECK P.C. BOARD CONNECTORS:

- (1) If power board checks good, remove electrical power from equipment.
- (2) Check P.C. board connectors using procedure given in Item 2, paragraph K.
- (3) If P.C. board connectors check good, replace logic board. Refer to REPAIR PARTS LIST for replacement part number.

15. BOBBIN MOTOR WILL NOT OPERATE

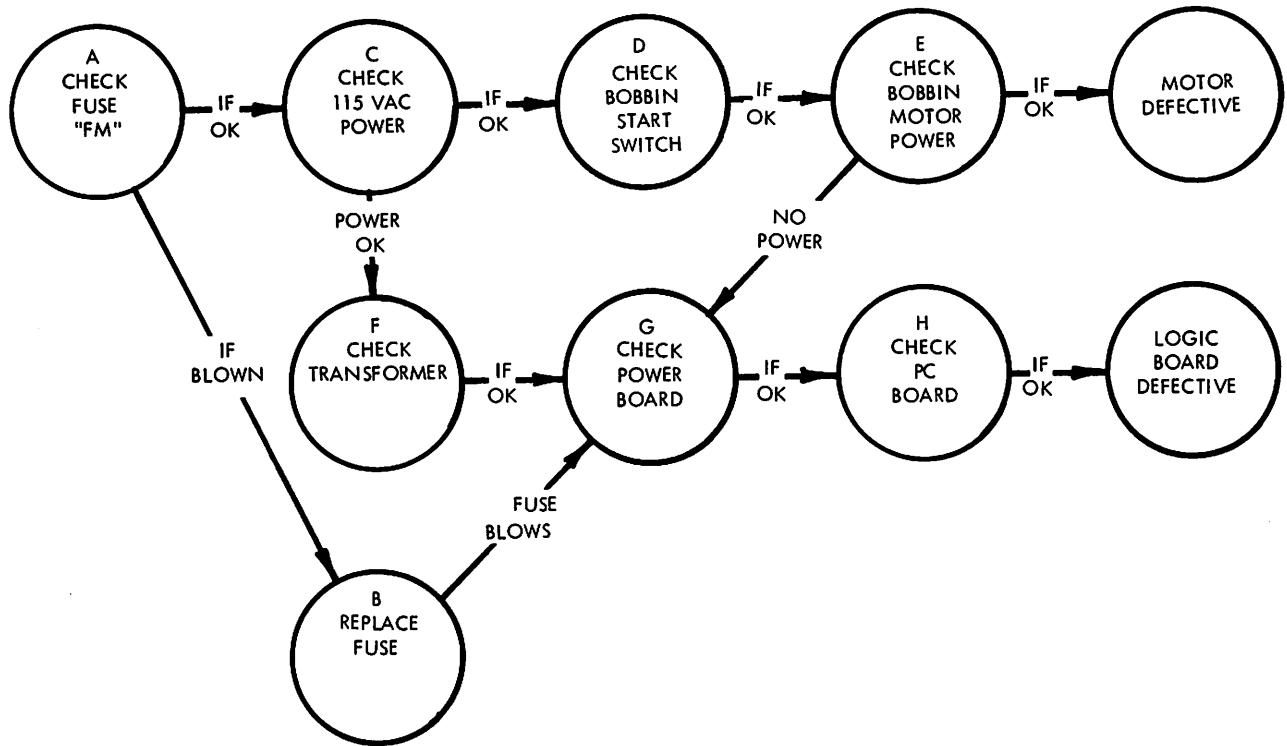

A. CHECK FUSE "FS":

(1) Remove fuse holder "FM" on rear of control box and check fuse.

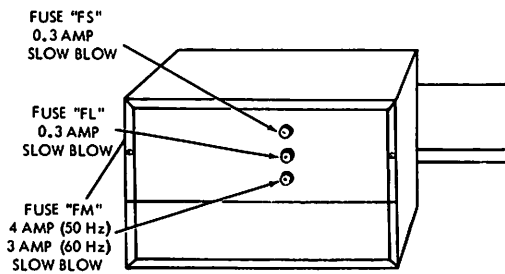

(2) If fuse does not appear to be blown, verify fuse condition by checking for continuity through fuse with ohmmeter. If fuse is good, go to paragraph C.

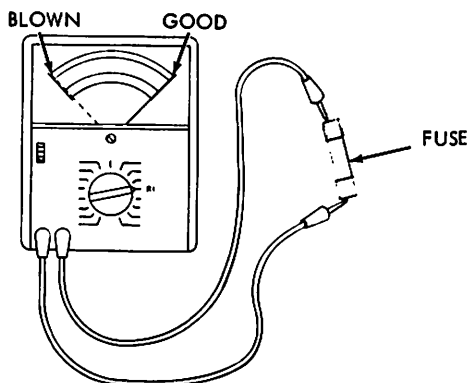

15. BOBBIN MOTOR WILL NOT OPERATE

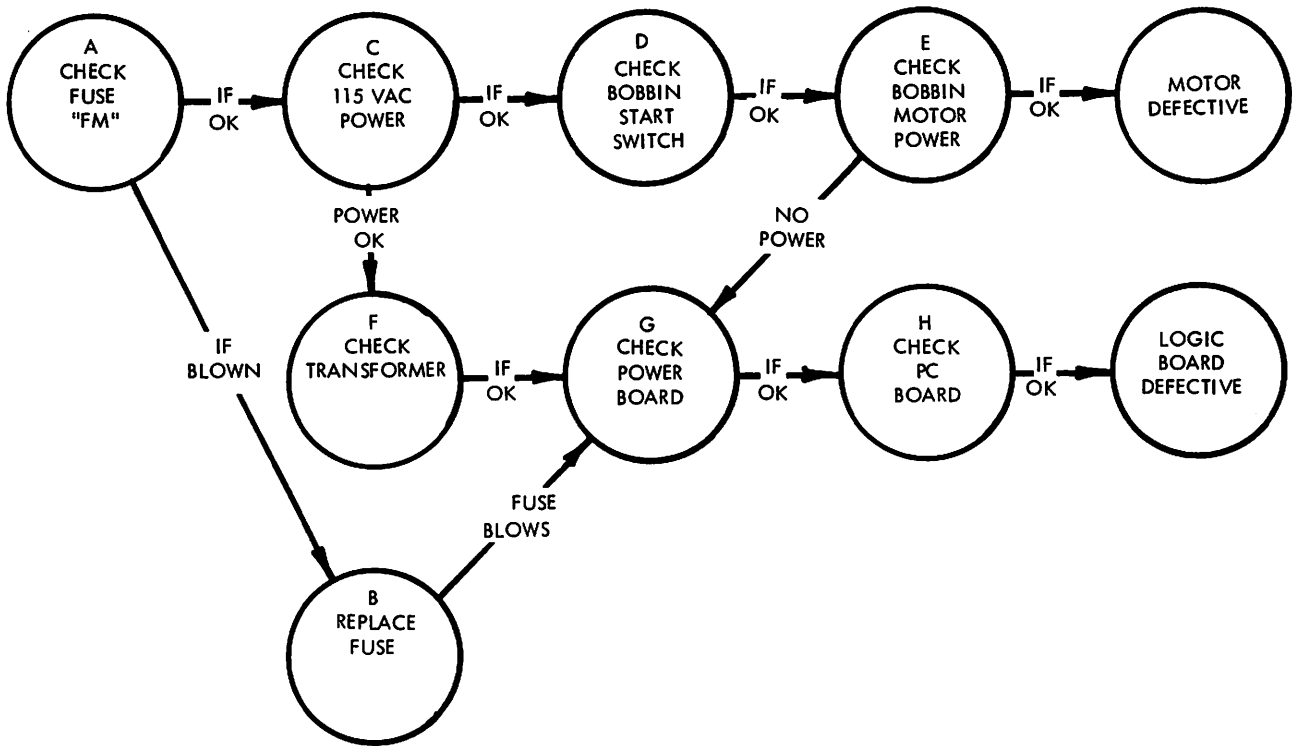

A. CHECK FUSE "FM":

(1) Remove fuse holder "FM" on rear of control box and check fuse.

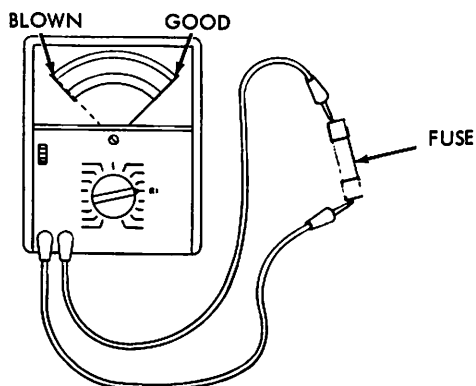
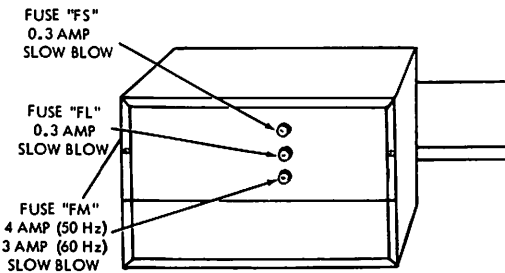

(2) If fuse does not appear to be blown, verify fuse condition by checking for continuity through fuse with ohmmeter. If fuse is good, go to paragraph C.

B. REPLACE FUSE:

- (1) If fuse is blown, replace with good fuse of proper value and recheck system. (Refer to REPAIR PARTS LIST for fuse part number).
- (2) If fuse blows when replaced, go to paragraph G.
- (3) If system operates properly after fuse is replaced, observe unit through several operating cycles with bobbin motor running and machine operating.

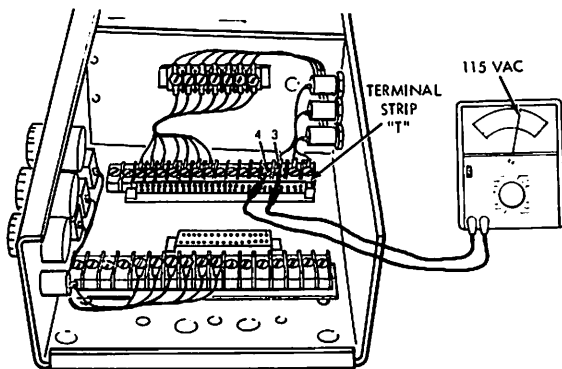

C. CHECK 115 VAC POWER:

- (1) If fuse "FM" checks good, remove control box cover and get voltmeter capable of reading in 120 volt AC range.
- (2) Connect voltmeter leads between terminals 3 and 4 on terminal board "T". Voltmeter should read 115 volts AC.
- (3) If voltmeter does not read 115 volts AC, go to paragraph F.

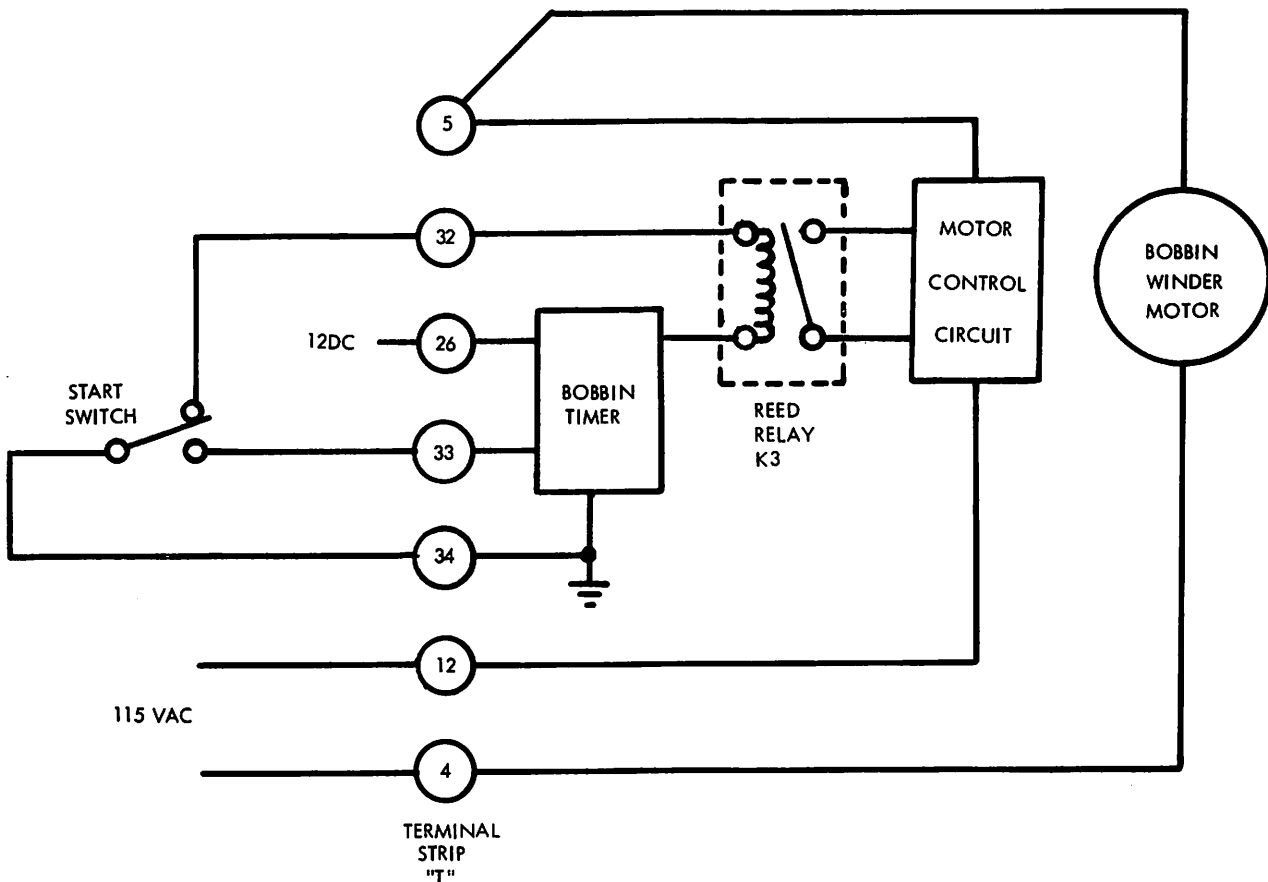

B. REPLACE FUSE:

(1) If fuse is blown, replace with good fuse of proper value and recheck system. (Refer to REPAIR PARTS LIST for fuse part number).

(2) If fuse blows when replaced, go to paragraph G.

(3) If system operates properly after fuse is replaced, observe unit through several operating cycles with bobbin motor running and machine operating.

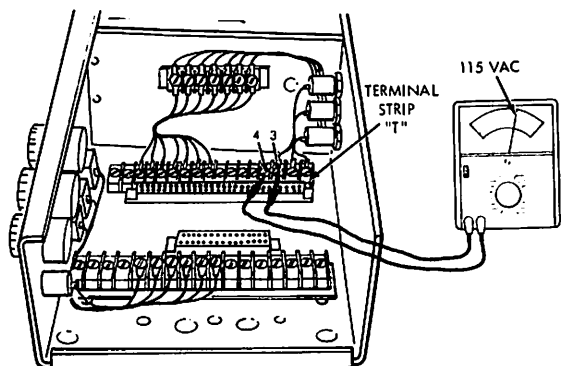

C. CHECK 115 VAC POWER:

(1) If fuse "FM" checks good, remove control box cover and get voltmeter capable of reading in 120 volt AC range.

(2) Connect voltmeter leads between terminals 3 and 4 on terminal board "T". Voltmeter should read 115 volts AC.

(3) If voltmeter does not read 115 volts AC, go to paragraph G.

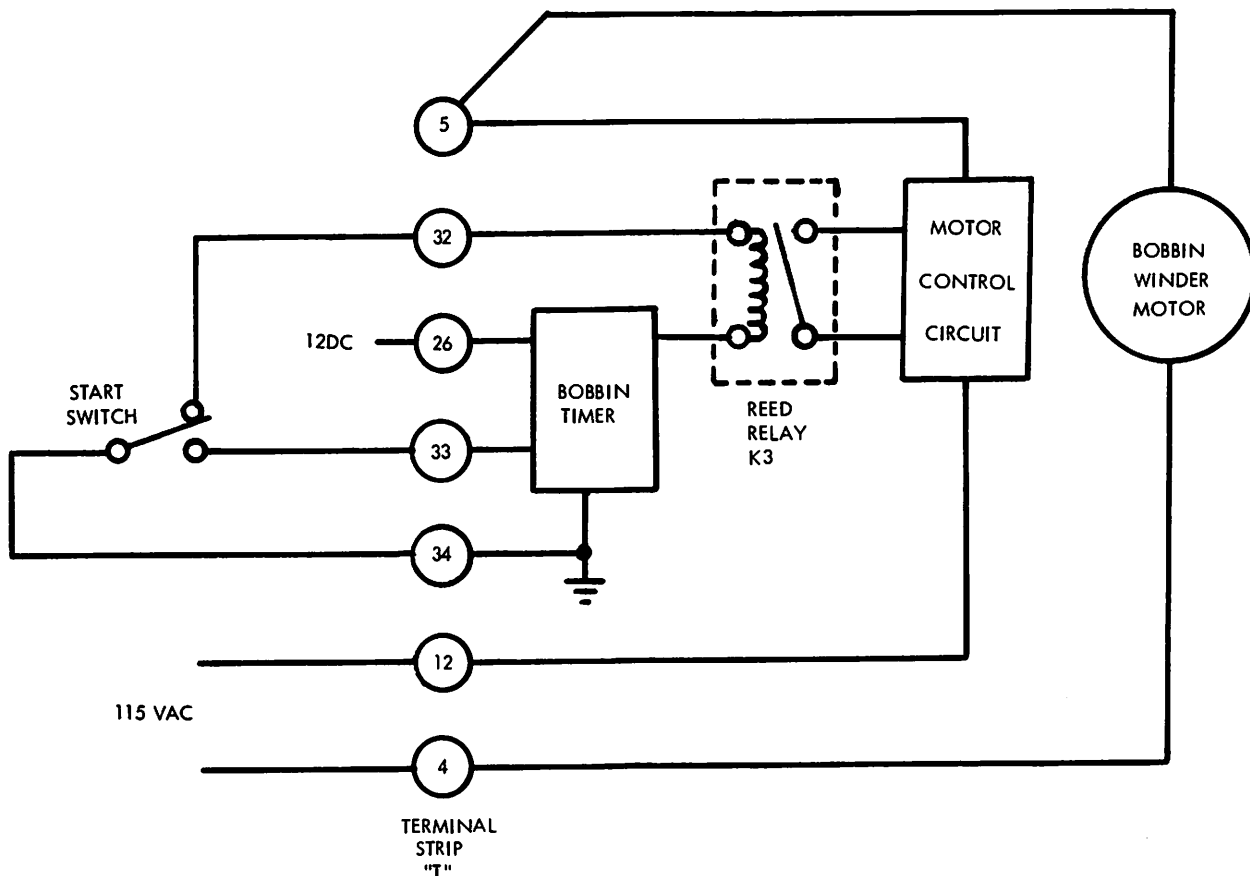

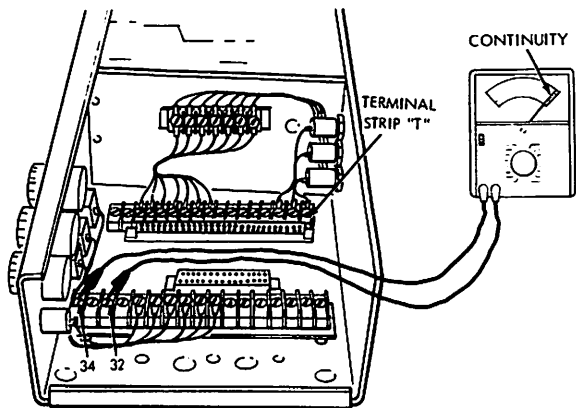

D. CHECK BOBBIN START SWITCH:

(1) If 115 volt power checks good, turn CONTROL POWER switch off. Get ohmmeter.

(2) Remove cover from control box and pull power board and logic board out.

(3) Connect ohmmeter leads between terminals 32 and 34 on terminal board "T". Ohmmeter should read continuity with bobbin start button in unactuated position.

(4) Press start button while observing ohmmeter indication. Ohmmeter indication should go from continuity to open when start button is pressed.

(5) Remove lead from terminal 32 and connect it to terminal 33. Ohmmeter should read open with start button in unactuated position.

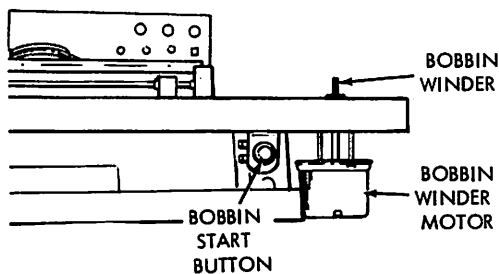

(6) Press start button while observing ohmmeter reading. Ohmmeter indication should go from open to continuity when start button is pressed.

(7) If proper indications are not read on ohmmeter in steps (3) through (6) replace start switch.

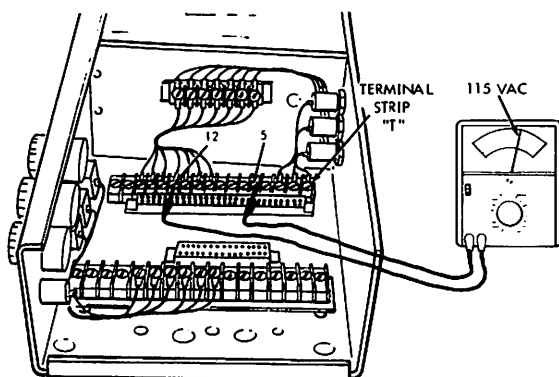

E. CHECK BOBBIN MOTOR POWER:

(1) If bobbin start switch checks good, connect an AC voltmeter between pins 5 and 12 of terminal strip "T". Remove thread from bobbin winder.

(2) Press bobbin start button and release it. If voltmeter reads 115 volts AC after bobbin start button is released, bobbin motor is defective.

(3) If voltmeter does not read 115 volts AC after bobbin start button is released, go to paragraph G.

F. CHECK TRANSFORMER:

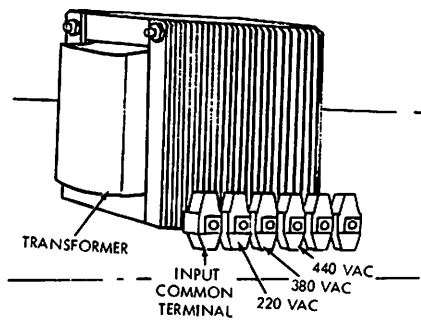

(1) If no 115 volt AC power is present at terminals 3 and 4 of terminal strip "T" check transformer.

(2) Refer to Item 3, paragraph I for transformer test procedure.

G. CHECK POWER BOARD:

(1) If transformer checks good, remove cover from control box.

(2) Check power board using procedure given in Item 2, paragraph J, steps (2) through (23).

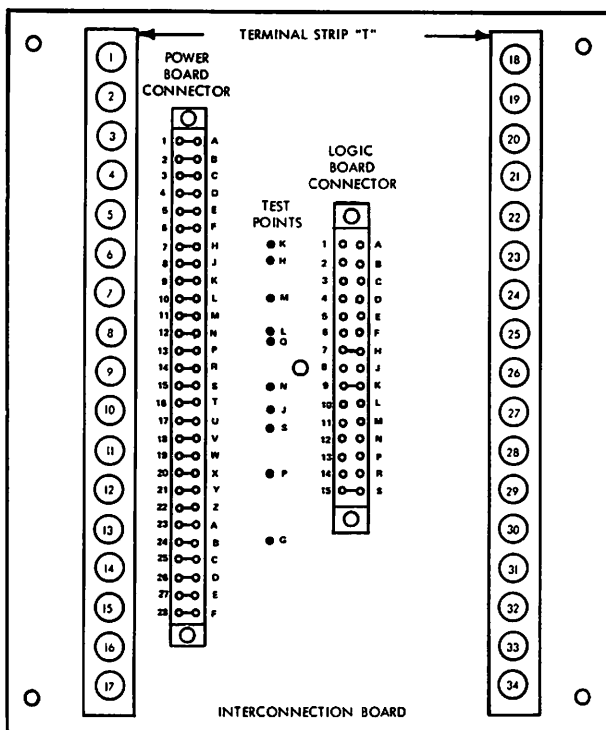

H. CHECK P.C. BOARD CONNECTORS:

(1) If power board checks good, remove electrical power from equipment.

(2) Check P.C. board connectors using procedure given in Item 2, paragraph K.

(3) If P.C. board connectors check good, replace logic board. Refer to REPAIR PARTS LIST for replacement part number.

16. MACHINE DOES NOT BACK-TACK

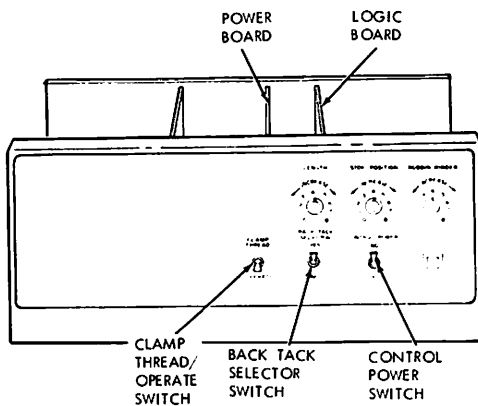
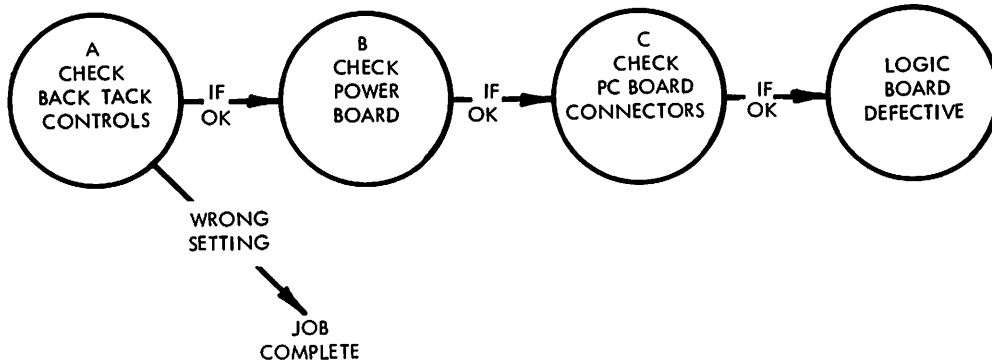

A. CHECK BACK-TACK CONTROLS:

(1) Check setting of back-tack controls. BACK-TACK switch should be set to YES position, and potentiometer should not be in full counter-clockwise setting.

(2) If either control is not properly set, reset control and recheck equipment. If machine operates properly, there are no defects in equipment.

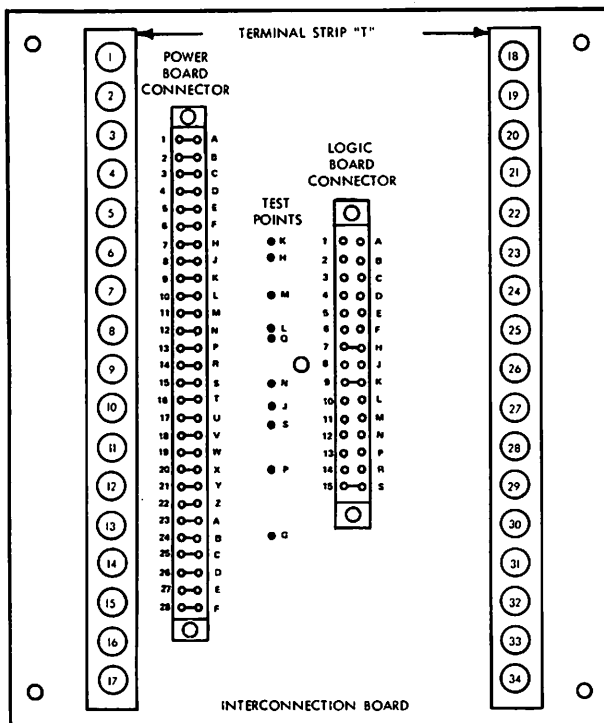

B. CHECK POWER BOARD:

(1) If control settings are correct, remove cover from control box.

(2) Check power board using procedure given in Item 2, paragraph J, Steps (2) through (23).

C. CHECK P.C. BOARD CONNECTORS:

(1) If power board checks good, remove electrical power from equipment.

(2) Check P.C. board connectors using procedure given in Item 2, paragraph K.

(3) If P.C. board connectors check good, replace logic board. Refer to REPAIR PARTS LIST for replacement part number.

17. MACHINE STOPS, THEN TACKS FORWARD WHEN SET TO BACK TACK

ITEM NO. 17

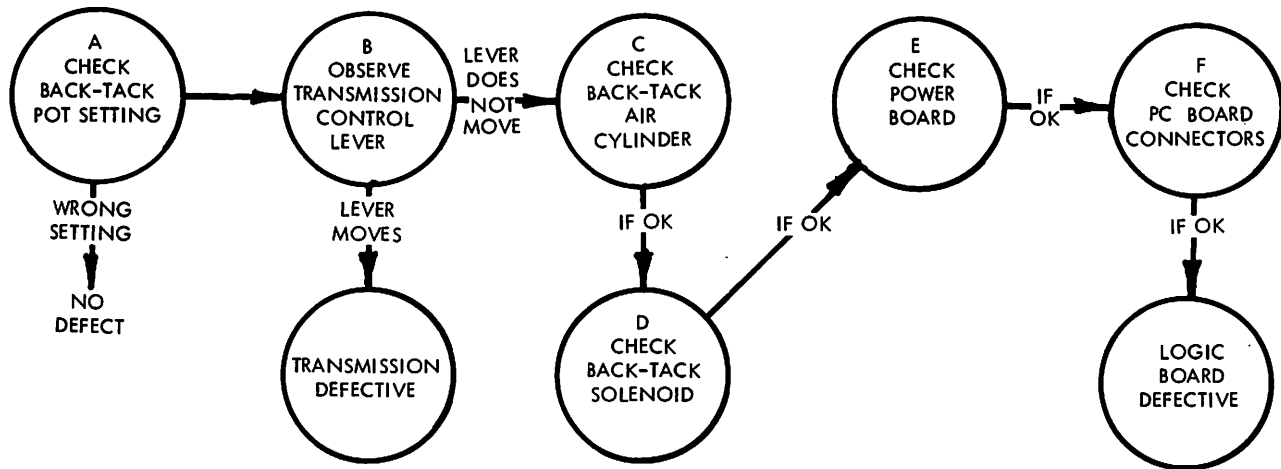

A. CHECK BACK-TACK POT SETTING:

(1) Check setting of BACK-TACK pot on control panel. If BACK-TACK pot is set at zero (to extreme left) adjust pot to desired setting.

(2) Recheck equipment operation with pot set to correct position. If machine now back-tacks properly, there is no defect.

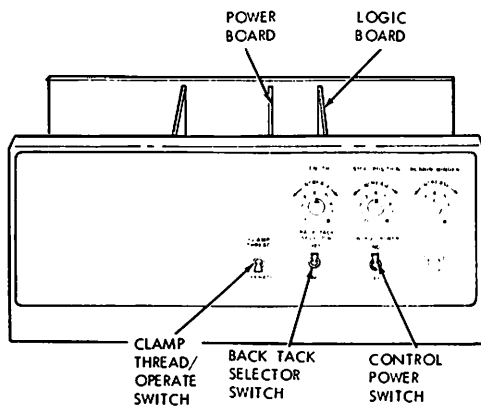

B. OBSERVE TRANSMISSION CONTROL LEVER:

(1) Operate system and observe transmission control lever during end of cycle. Air cylinder should move transmission control lever into reverse position.

(2) If transmission control lever moves to reverse position, and machine does not reverse, transmission is defective.

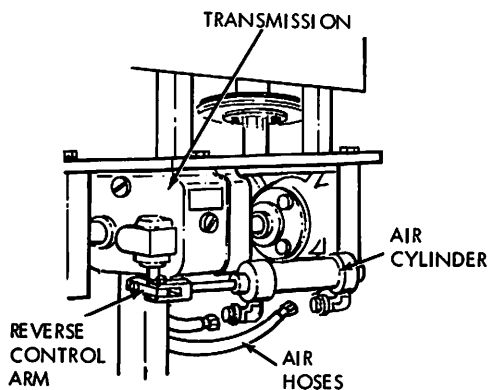

C. CHECK BACK-TACK AIR CYLINDER:

(1) If transmission control lever does not move at end of cycle, remove both air hoses from air cylinder on transmission.

(2) Manually move air cylinder piston rod in and out. Rod should move freely.

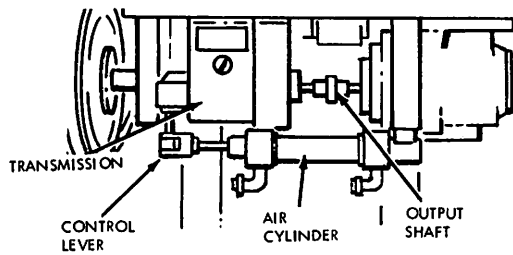

(3) If air cylinder piston rod does not move freely while connected to transmission control lever, disconnect rod from control lever to determine which unit is binding.

(4) If transmission control lever is binding, repair or replace transmission. If air cylinder piston rod is binding, replace air cylinder.

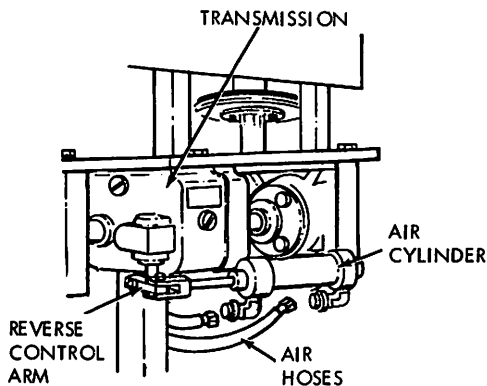

D. CHECK BACK-TACK SOLENOID:

(1) If back-tack air cylinder and transmission check good, leave air hoses disconnected from air cylinder.

(2) Operate unit while observing hose near piston rod end of air cylinder. Air should be released from hose during back-tack cycle time.

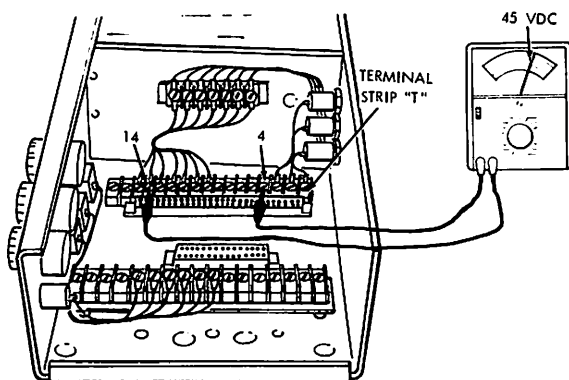

(3) If air is not released from proper hose of air cylinder, get voltmeter a capable of reading in 45 volt DC range.

(4) Connect positive voltmeter lead to terminal 4 of terminal strip "T" and connect negative lead to terminal 14. Operate machine through a complete cycle. Voltmeter should read 45 volts during back-tack cycle time.

(5) If voltmeter reads 45 volts DC, and back-tack solenoid does not energize, solenoid is defective.

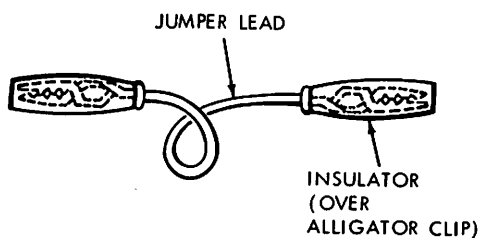

(6) If voltmeter does not read 45 volts DC, get jumper lead with insulated alligator clips on each end. Connect one end of jumper lead to terminal 14, and connect other end to terminal 17. Back tack solenoid should operate when jumper lead is connected.

(7) If back-tack solenoid does not operate when jumper is connected, repair or replace solenoid. Connect air hoses and remove jumper.

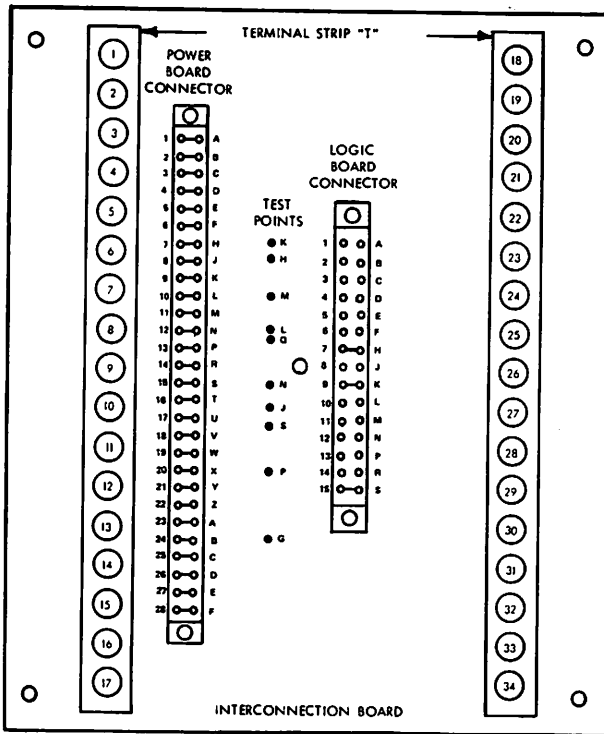

E. CHECK POWER BOARD:

- (1) If back-tack solenoid checks good, remove cover from control box.
- (2) Check power board using procedure given in Item 2, paragraph J, Steps (2) through (23).

F. CHECK P.C. BOARD CONNECTORS:

- (1) If power board checks good, remove electrical power from equipment.
- (2) Check P.C. board connectors using procedure given in Item 2, paragraph K.
- (3) If P.C. board connectors check good, replace logic board. Refer to REPAIR PARTS LIST for replacement part number.

MAIN MOTOR TROUBLESHOOTING

NOTE

If difficulties in needle positioning are encountered, check positioner circuitry on the motor control panel.

CONDITION	CAUSES	CURES
Unit does not position	Blown fuse on motor control panel Synchronizer plug not connected Synchronizer leads not connected to plug	Replace fuse 998-223-2.5 Plug synchronizer plug into right socket of main motor control panel Check leads continuity between brush holder and plug
Machine will not stop after sewing and continues to rotate at inching speed	Microswitch on right side of clutch arm not adjusted properly Defective microswitch	Adjust screw on right side of clutch arm counterclockwise until machine stops, and then make one more turn Replace microswitch 998-233
Solenoids do not energize	Synchronizer not adjusted properly Relay 4 coil not energizing due to bent contacts	Readjust synchronizer per instructions Reshape contacts of relay 3
Machine stops down	Microswitch in clutch arm closed at all times. Defective microswitch	Replace microswitch 998-286
Unit positions up and trims and thread pulls out of needle	Tension opening late	Relay 4 is sticking. Replace board
Unit positions very slowly	Positioning belt stretched out of shape Not enough clearance space in auxiliary clutch	Replace belt 998-235 Put additional spacers in auxiliary clutch 995-218
Klipp-It knives stick in open position	Relay points pitted	Replace or clean relay points in auxiliary control box

SEWING HEAD TROUBLESHOOTING

CONDITION	CAUSES	CURES
Skipped stitches or thread breakage	Burred needle	Replace needle
	Wrong needle	Replace with either 135-RMN-116 or 135-RMN-216
	Needle incorrectly inserted in needle bar	Realign needle so needle eye faces operator
	Burr in needle hole in throat plate	Polish out needle hole
	Needle hole too large	Replace throat plate RM-2385 D
	Burrs on inside edges of clamp slot	Polish edges
	Burr on hook point. Hook out of time	Polish hook point. Retime hook, Section IV
	Bobbin case damaged	Replace bobbin case 63913 B
TRIMMER TROUBLESHOOTING		
Both threads not cut	Solenoid not working	Check lead connections. Make continuity check
	Lower knife not moving far enough right	Reset stop screw
	Lower knife too far forward	Relocate knife. Check for nicks on radius
	Lower knife too far back	Relocate knife
Needle thread not cut, but bobbin thread cut	Broken spring retainer wire	Replace with 63450 A
	Spring retainer wire not contacting bobbin case holder when in catching position	Bend spring retainer wire to suit
	Lower knife does not move far enough to right	Adjust stop screw to standard setting. Check position of solenoid. Operate machine with belt off to determine if solenoid pivot lever is contacting stop screw; and then reposition solenoid if necessary
	Bobbin case improperly threaded	Thread properly
	Needle hole in throat plate too big	Replace throat plate with RM-2385 D
Lower knife does not return all the way	Not enough tension on lower knife return spring. Dense material and rough thread will require more tension on knife return spring	Increase tension on lower knife return spring by moving bracket right
	Lower knife rubbing hook point	Raise lower knife

(continued)

CONDITION	CAUSES	CURES
Needle thread tears and leaves random lengths of starting tail	<p>Too much knife return spring tension and excessive friction in needle thread eyelets and in thread pull-off at cone</p> <p>Tension disc not open</p>	<p>Unthread some of the eyelets to the right of the tension post. Slightly decrease tension on knife return spring. Check thread pull-off at cones</p> <p>Check setting of tension release solenoid and electrical operation of solenoid</p>
Needle unthreads when starting	Needle thread take-up not positioned properly at top of stroke	Check position of needle thread take-up. Must be within 1/8 inch of the top of unstroke
Bobbin thread breaks	<p>Overspin on bobbin thread</p> <p>Too much knife return spring tension</p>	<p>Check wind of bobbin and fit of bobbin in bobbin case holder</p> <p>Slightly decrease tension on knife return spring by moving bracket left</p>



Union Special[®]
INDUSTRIAL SEWING MACHINES

UNION SPECIAL maintains sales and service facilities throughout the world. These offices will aid you in the selection of the right sewing equipment for your particular operation. Union Special representatives and service men are factory trained and are able to serve your needs promptly and efficiently. Whatever your location, there is a Union Special Representative to serve you. Check with him today.

ATLANTA, GA.

BOSTON, MASS.

CHICAGO, ILL.

DALLAS, TEXAS

LOS ANGELES, CAL.

NEW YORK, N. Y.

PHILADELPHIA, PA.

MONTREAL, CANADA

TORONTO, CANADA

BRUSSELS, BELGIUM

LEICESTER, ENGLAND

LONDON, ENGLAND

PARIS, FRANCE

STUTT GART, GERMANY

Representatives and distributors in all important industrial cities throughout the world.

Union Special[®]
CORPORATION

400 N. FRANKLIN ST., CHICAGO, ILL. 60610