

FINEST QUALITY

Union Special[®]
LEWIS • COLUMBIA

**INDUSTR
SEWING
MACHINE**

**LIST OF PARTS
FOR
STYLES IN CLASS
41300**

CUP FEED MACHINES

**CATALOG
No.
78 M
Third
Edition**

Union Special MACHINE COMPANY
CHICAGO

From the library of: Superior Sewing Machine & Supply LLC

Catalog No. 78 M

LIST OF PARTS

STYLES IN CLASS

41300

CUP FEED MACHINES

The parts listed in this catalog are furnished at list prices for repairs only.

Third Edition

Copyright 1948

by

Union Special Machine Co.

Rights Reserved in All Countries

Union Special
MACHINE COMPANY
INDUSTRIAL SEWING MACHINES
CHICAGO

Printed in U.S.A.

FOREWORD

It is our constant aim to furnish carefully prepared information that will enable the customer to secure all possible economies and advantages from the use of Union Specials. On the pages which follow will be found illustrations and descriptions of the parts for styles in Class 41300 - Cup Feed Machines.

Additional catalogs, containing information relative to these machines, and which will be furnished upon request, are listed below.

Catalog No. 45 N Needle Manual
Catalog No. 78 Instructions for Installing
Form 357 Engineering Department
Adjusting Instructions.
Specify the style number of
the machine for which the
adjusting instructions are
required.

In all manufacturing centers will be found Union Special representatives, who will cooperate with those who desire in planning and estimating their requirements.

Union Special MACHINE COMPANY

Engineering Department

IDENTIFICATION OF MACHINES

Each Union Special carries a style number which is stamped in the name plate on the machine. Style numbers are classified as standard and special. Those which are standard have one or more letters suffixed, but never contain the letter "Z". Example: 41300 A. Style numbers containing the letter "Z" are special. When only minor changes are made in a standard machine a "Z" is merely suffixed to the respective standard style number. Example: 41300 AZ.

Styles of machines similar in construction are grouped under a class number which differs from the style numbers in that it contains no letters. Example: 41300.

APPLICATION OF CATALOG

This catalog applies only to the standard styles of machines as listed herein. It can also be applied with discretion to the special machines in Class 41300.

STYLES OF MACHINES IN CLASS 41300

Cup Feed Machines, Overedge Stitch, Gear Driven Outer Cup

- 41300 A (Succeeds 41200 AA) For seaming chiffon weight full fashioned silk hosiery commonly known as 1, 2, and 3 thread, two end stitch, Type 503, stitch range 22 to 14 per inch, Type 155 A needle.
- 41300 B For seaming all weights full fashioned silk hosiery, two end stitch, Type 503, stitch range 22 to 14 per inch, Type 155 A needle.
- 41300 C For seaming chiffon weight full fashioned silk hosiery commonly known as 1, 2, and 3 thread, three end stitch, Type 504, stitch range 22 to 14 per inch, Type 155 A needle.
- 41300 D For seaming all weights full fashioned silk hosiery, three end stitch, Type 504, stitch range 22 to 14 per inch, Type 155 A needle.
- 41300 E For mock seaming all weights hosiery, two end stitch, stitching spec. 503-OSf-1, stitch range 22 to 14 per inch, Type 155 A needle.
- 41300 F (Succeeds 41300 A). For seaming chiffon weight full fashioned silk hosiery commonly known as 1, 2, and 3 thread, two end stitch, seam spec. 503-SSa-1, stitch range 22 to 14 per inch, Type 155 A needle.
- 41300 G (Succeeds 41300 B). For seaming all weights full fashioned silk hosiery, two end stitch, seam 503-SSa-1, stitch range 22 to 14 per inch, Type 155 A needle.

STYLES OF MACHINES IN CLASS 41300 (Cont'd.)

- 41300 H (Succeeds 41300 C). For seaming chiffon weight full fashioned silk hosiery commonly known as 1, 2, and 3 thread, three end stitch, seam spec. 504-SSa-1, stitch range 22 to 14 per inch, Type 155 A needle.
- 41300 J (Succeeds 41300 D). For seaming all weights full fashioned silk hosiery, three end stitch, seam spec. 504-SSa-1, stitch range 22 to 14 per inch, Type 155 A needle.
- 41300 K Same as 41300 F, except equipped for seaming 30 to 40 denier nylon hosiery, equivalent in weight to two and three thread silk hosiery, Type 155 A needle.
- 41300 L Same as 41300 G, except equipped for seaming all weights nylon hosiery, pulling attachment, Type 155 A needle.
- 41300 M Same as 41300 H, except equipped for seaming 30 to 40 denier nylon hosiery, equivalent in weight to two and three thread silk hosiery, automatic thread ratio control and pulling attachment, Type 155 A needle.
- 41300 N Same as 41300 J, except equipped for seaming all weights nylon hosiery, automatic thread ratio control and pulling attachment, Type 155 A needle.
- 41300 P For seaming chiffon weight full fashioned silk hosiery commonly known as 1, 2, and 3 thread, with circular heel and continuous seam from toe to welt, three end stitch, seam spec. 504-SSa-1, stitch range 22 to 14 per inch, knee controlled device for increasing height of uncurler, and automatic thread ratio control, Type 155 A needle.
- 41300 Q Same as 41300 P, except equipped for seaming all weights full fashioned silk hosiery, with circular heel and continuous seam from toe to welt, Type 155 A needle.
- 41300 R Same as 41300 P, except equipped for seaming 30 to 40 denier nylon hosiery, with circular heel and continuous seam from toe to welt, equivalent in weight to two and three thread silk hosiery, Type 155 A needle.
- 41300 S Same as 41300 P, except equipped for seaming all weights nylon hosiery, with circular heel and continuous seam from toe to welt, Type 155 A needle.
- 41300 T (Succeeds 41300 F, 41300 G, 41300 H, 41300 J, 41300 M, 41300 N, 41300 P, 41300 Q, 41300 R, 41300 S). For seaming all weights of cotton, rayon, silk, or nylon full fashioned hosiery, with circular heel and continuous seam from toe to welt, or conventional square heel. Equipped for both two end and three end stitch, seam specifications 503-SSa-1 or 504-SSa-1, stitch range 14 to 22 per inch, needle guard and stitch tongue support .065 inch

STYLES OF MACHINES IN CLASS 41300 (Cont'd)

41300 T (Cont'd) high, knee controlled device for increasing height of uncurler, automatic thread ratio control for three end stitch, fabric pulling and chain cutting attachment, Type 155 A needle.

41300 U (Succeeds 41300 F, 41300 G). Same as 41300 T except equipped for two end stitch, seam specification 503-SSa-1 only.

41300 V (Succeeds 41300 H, 41300 J, 41300 M, 41300 N) Same as 41300 T except equipped for three end stitch, seam specification 504-SSa-1 only.

41300 W Same as 41300 T, except equipped with needle guard and stitch tongue support .055 inch high.

41300 Z A special style, similar to the standard styles in Class 41300, but differing in one or more of its component parts.

ORDERING REPAIR PARTS

PLATES

Illustrations of parts are arranged according to scale and, wherever possible, parts similar in appearance or function are grouped together.

When a given design of part is made in two or more sizes, only one illustration is usually shown. In ordering these pieces, it is necessary that the additional information be furnished as requested under these illustrations.

LIST OF PARTS

Turning from the plates to the list of parts, the description of each part and its principal uses will be found. Always check the symbol against its description before ordering. It is not necessary to furnish the plate number.

When a part is used, or can be used, in all machines covered by this catalog, no specific use is mentioned in the description.

For convenience in ordering, minor parts such as screws, nuts and similar articles are repeated after each major part.

(-) A dash in the "plate number" column of the list of parts indicates the absence of an illustration.

(‡) A double dagger in the "symbol to order by" column indicates that the component parts cannot be furnished separately. Due to the high speed of these machines and other factors it is impossible for these associated parts to be fitted a second time and make a serviceable job.

ORDERING REPAIR PARTS (Continued)

IDENTIFYING PARTS

Where the construction permits, each part is stamped with its part number. On some of the smaller parts, and on those where construction does not permit, an identification letter is stamped in to distinguish the part from similar ones.

Part numbers represent the same part, regardless of catalog in which they appear.

IMPORTANT! ON ALL ORDERS, PLEASE INCLUDE PART NAME AND STYLE OF MACHINE FOR WHICH PART IS ORDERED.

SUPPLIES

All supplies, including taps, reamers, belting, belt hooks, belt fasteners, screw drivers, wrenches and powdered oil stone will be promptly furnished.

USE GENUINE NEEDLES AND REPAIR PARTS

Success in the operation of these machines can be secured only with genuine Union Special Needles and Repair Parts as furnished by the Union Special Machine Company, its subsidiaries and authorized distributors. They are designed according to the most approved scientific principles, and are made with utmost precision. Maximum efficiency and durability are assured.

Genuine needles are packaged with labels marked *Union Special*. Genuine repair parts are stamped with a reproduction of the familiar Union Special trade mark. Each trade mark is your guarantee of the highest quality in materials and workmanship.

TERMS

Prices are net cash and subject to change without notice. All shipments are forwarded f. o. b. shipping point. Parcel Post shipments are insured unless otherwise directed. A charge is made for express postage and insurance.

Plate 1 - Full Size

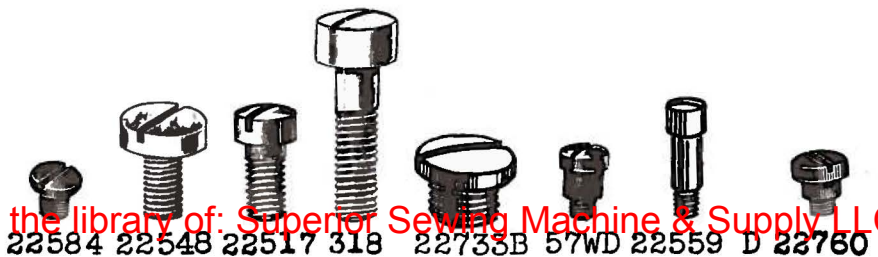
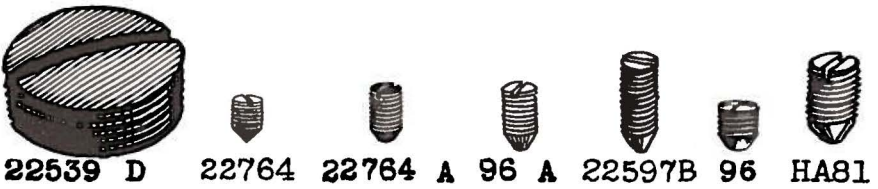

Plate 2 - Full Size



Plate 3 - Full Size

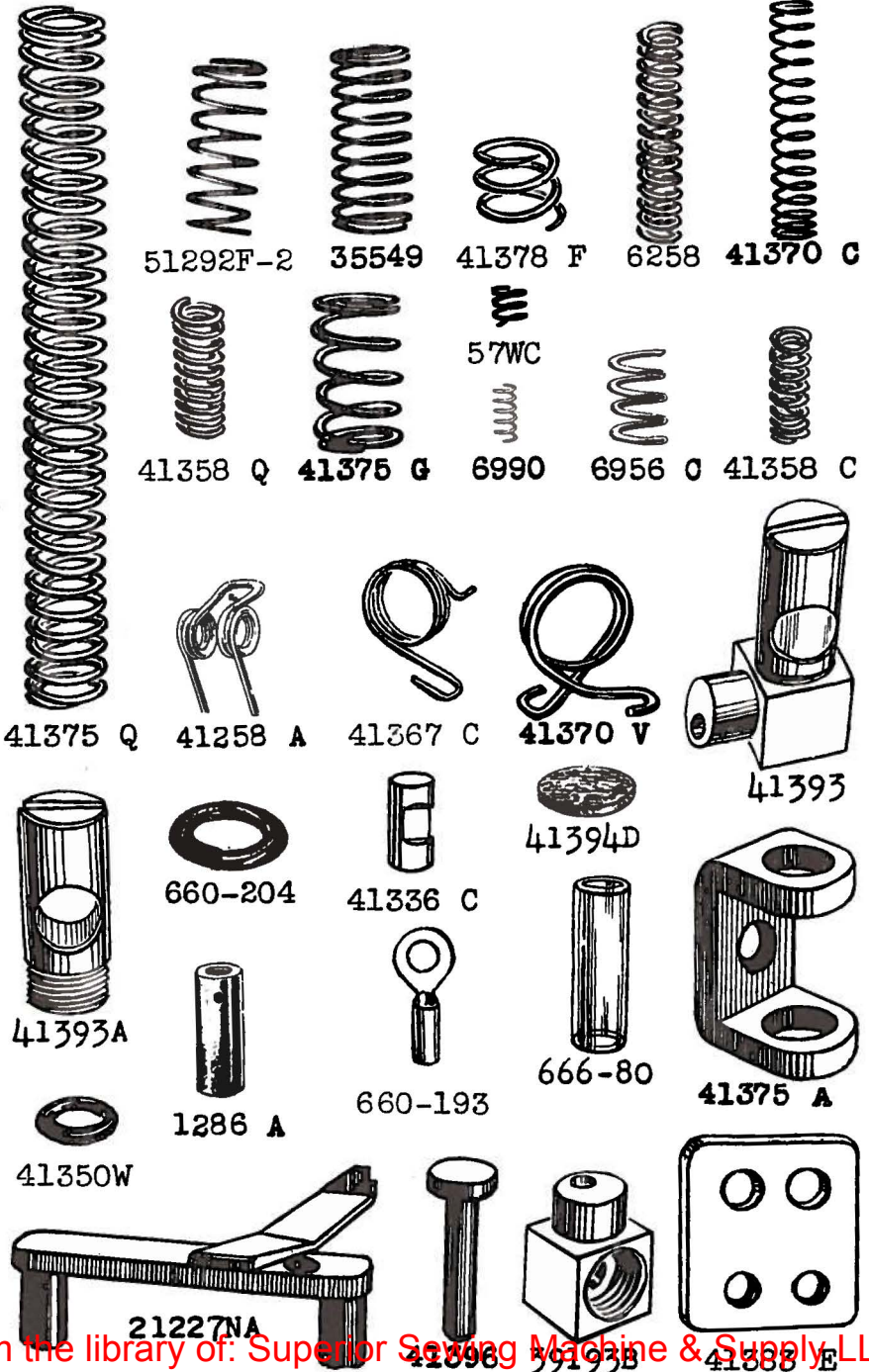

Plate 4 - Full Size



41332 B



41357 N

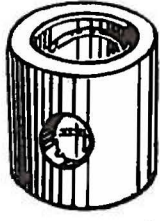

41390 B



21113B



41364 N



41363 U



41375 F



41343 C



41360 G



39147 D



41258



2339 F



41375 V



41039 A



41350 G



41037 A



41355



41350 V



41352A

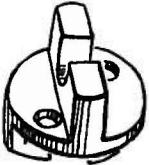

41363N



660-142



41332 P

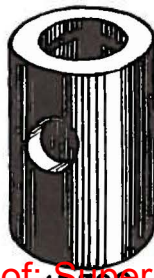

41390



41360



41362 &



41350

Plate 5 - Full Size

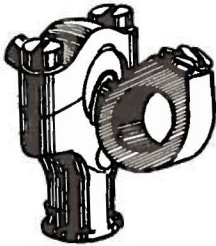

41332 F



41357 J



41355 K



41342 F

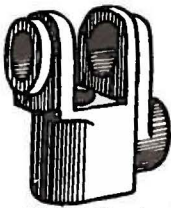

41350 A



41335 P



41332 H



41342 H

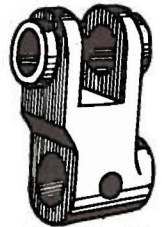

41335 N



668-26



109

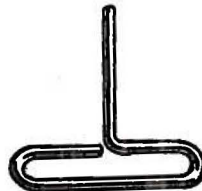

41343 B



57 WB



668-25



51292



21351 B



51292D



41298-5



41392



21350



41376 B

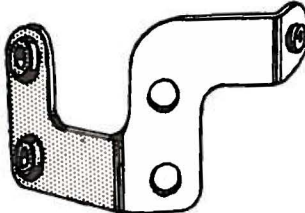

41376 G



41376 A



41376 F

Plate 6 - Full Size

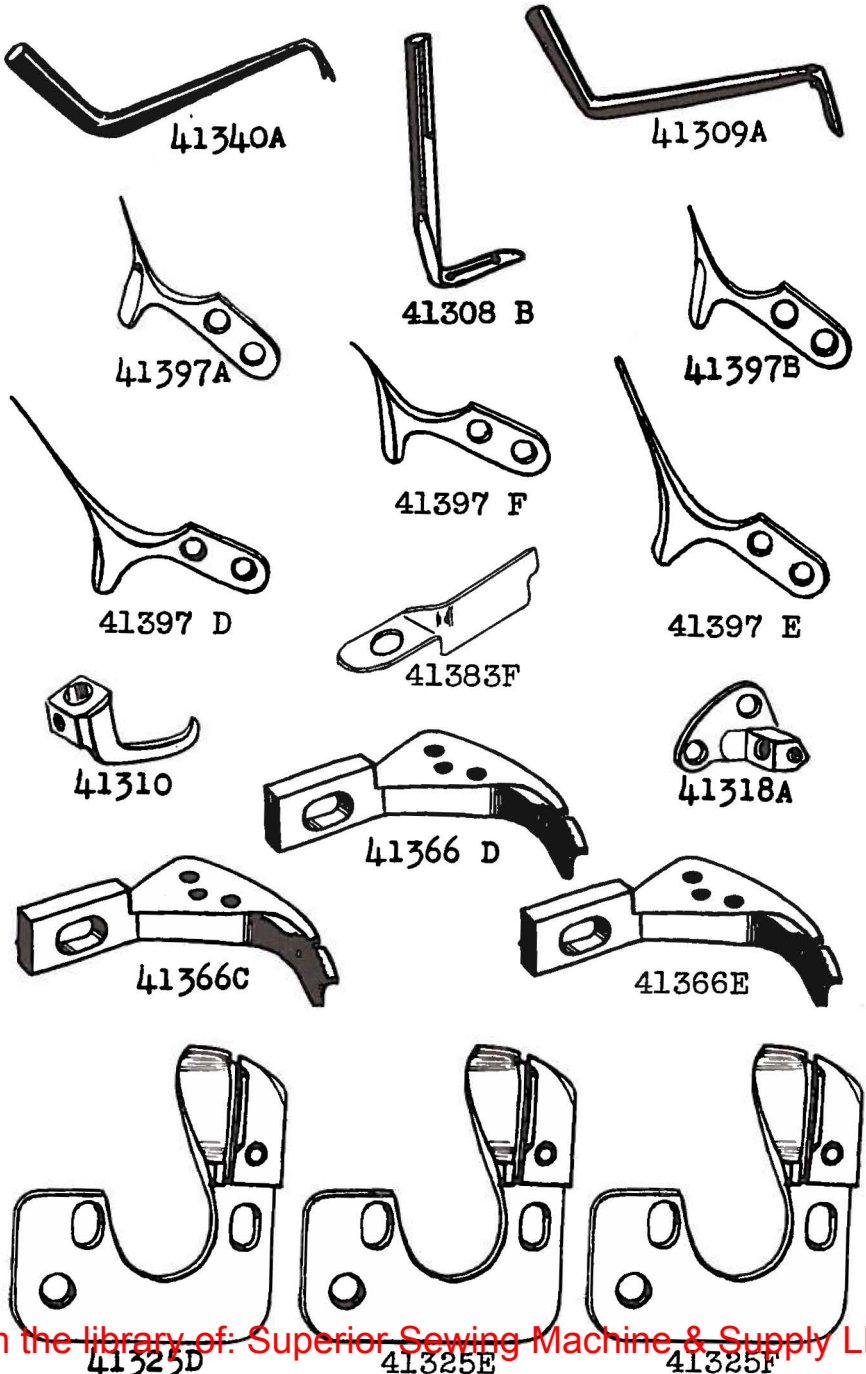
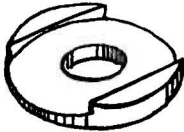

Plate 7 - Full Size



41358 A



41358 B

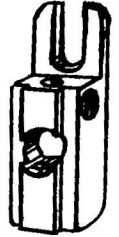

41370 AG

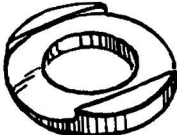

41358 R



41358 D



41370 AF



41370 U



41358 T

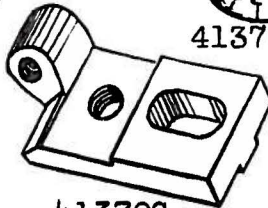

41370 G

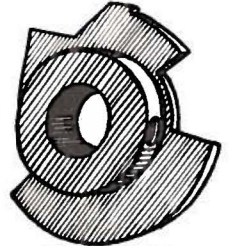

41370 N

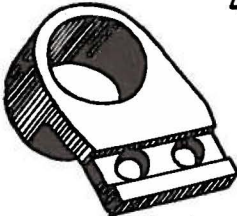

41370 A



41370 AE

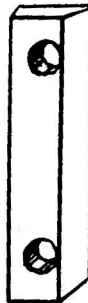

41370 AC

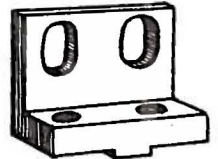

41366 N

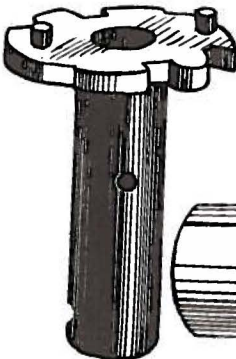

41370 P

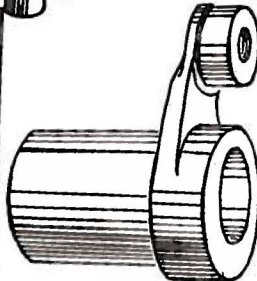

41370 AH

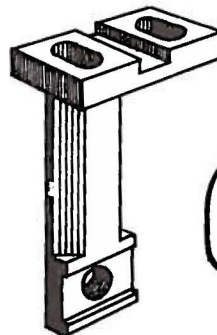

41366 G



41358 S

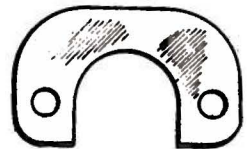

41345 G
Specify
Thickness



41258 B

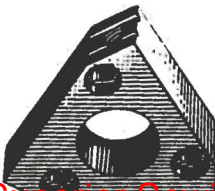

41258 E



41358 N



41358 P

Plate 8 - Full Size

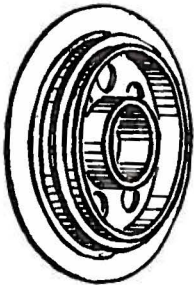

41378 U-64

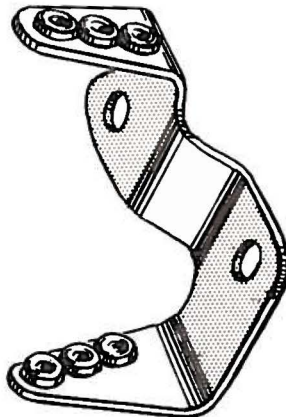

41378

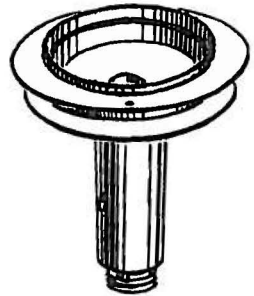

41378 T-56



41378 J



41378 R

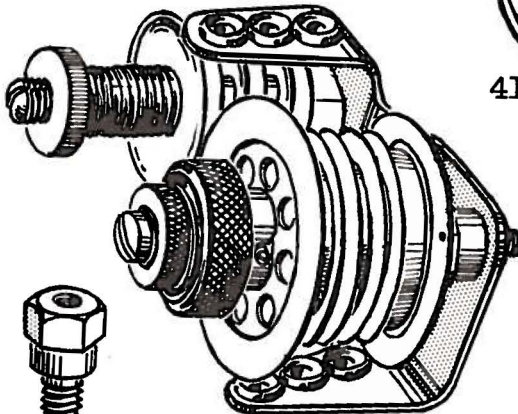

29485 C

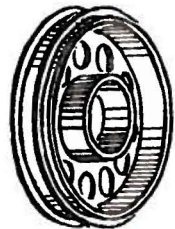

41378 B-64



41378 D



41378 C



41378 E



41378 S



41378 K



41367 G



41378 Q



41367 J

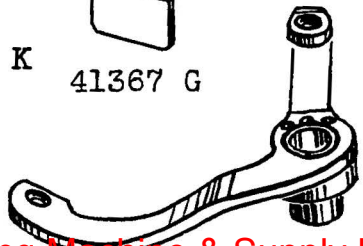

41367 K

Plate 9 - One-Half Size

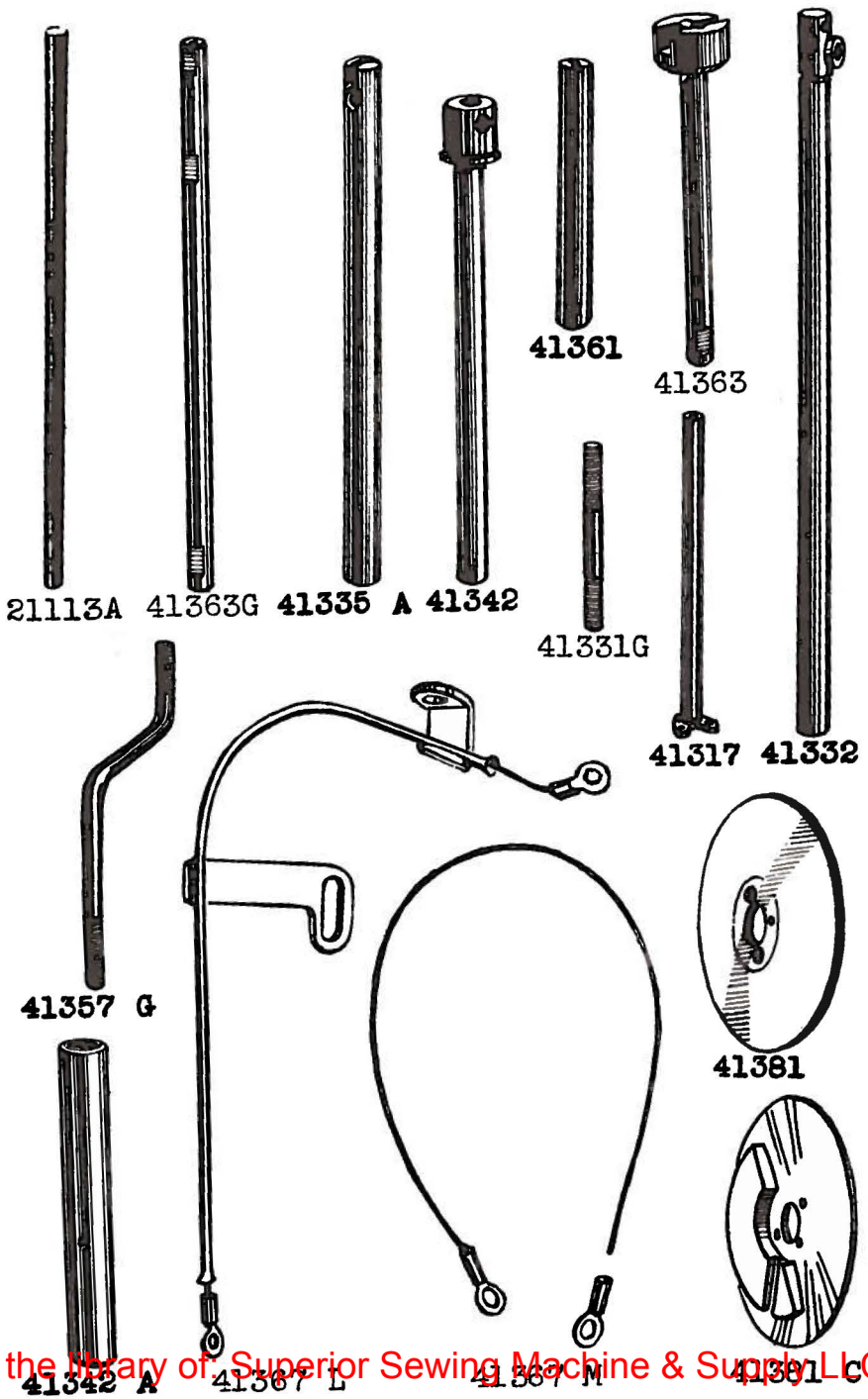

Plate 10 - One-Half Size



41362



41395



41362 A

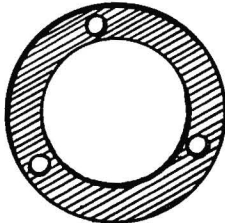

41394



41383



41336 D

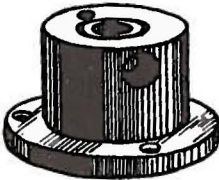

41390 A

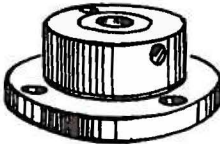

41390 C



41361 N

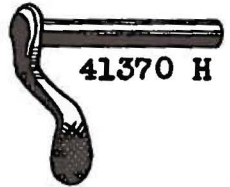

41370 H

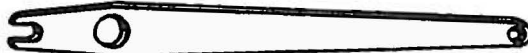

41370AD

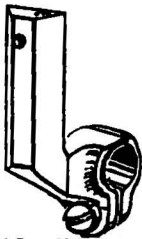

41370AB

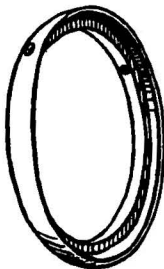

41391 G

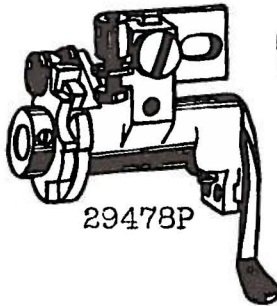

29478P

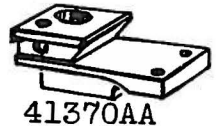

41370AA

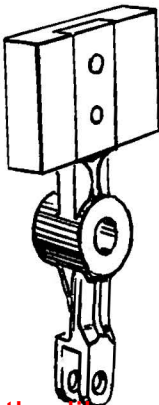

41336 A

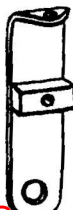

41377



41383C



41383 D

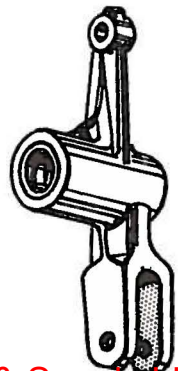

41335 B

Plate 11 - One-Half Size

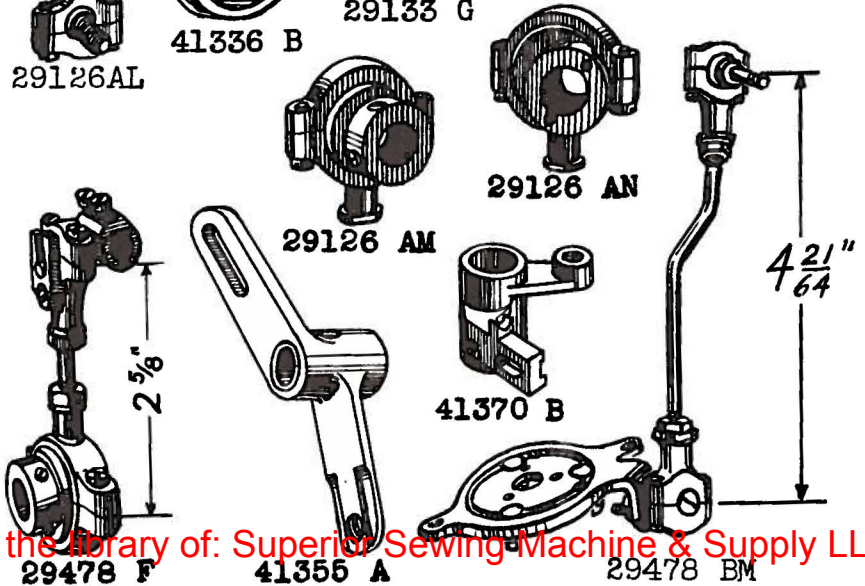
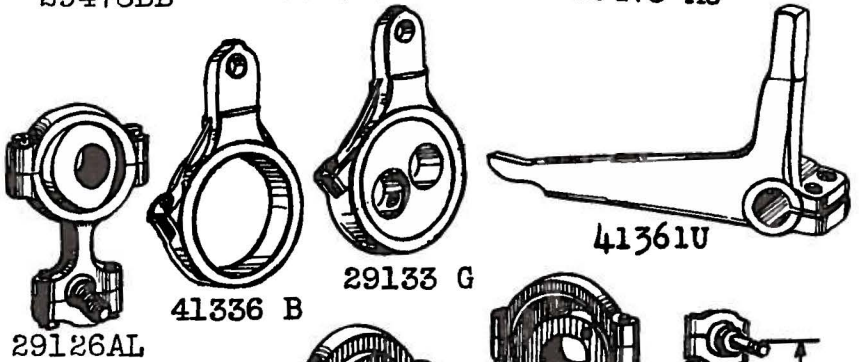
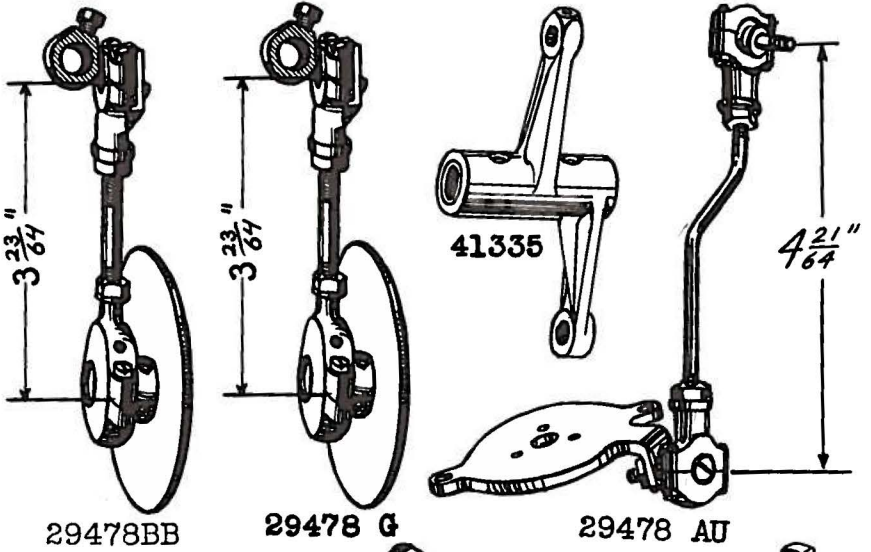
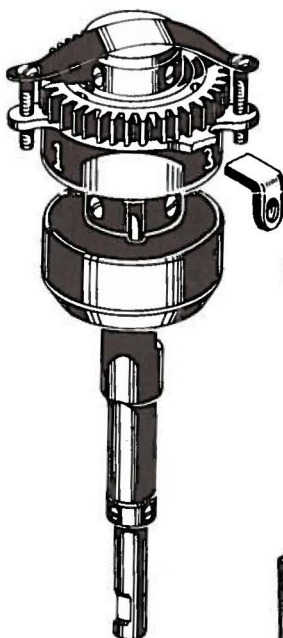

Plate 12 - One-Half Size



41358M



29478BP



41258 D



41363 J



41357 B



41364 G

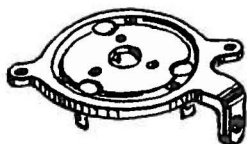

41357 C



41363 A

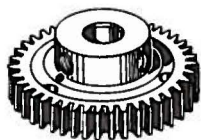

41365B

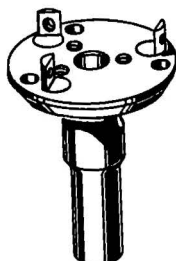

41364J



41365



41365 A

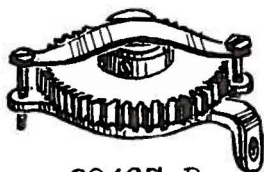

29467 B

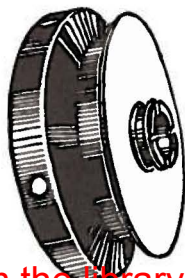

41321



41364

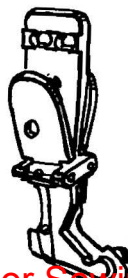

29450 M



K60161

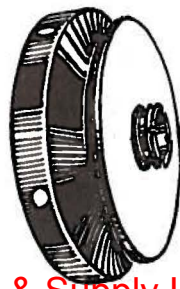

39121

Plate 13 - One-Half Size

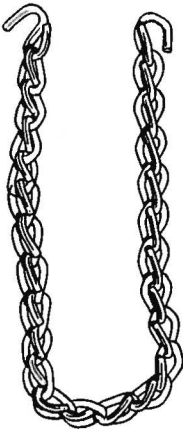

421 C
SPECIFY
LENGTH

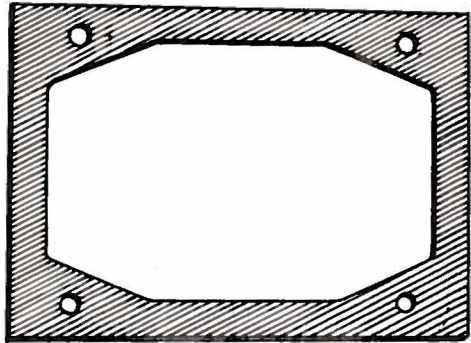

41394 C



21227 L

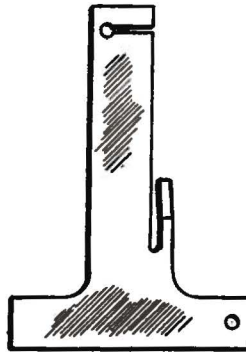

21225 D



118B



21388R



21388N



21388



21388 D



115

Plate 14 - One-Half Size



660-156

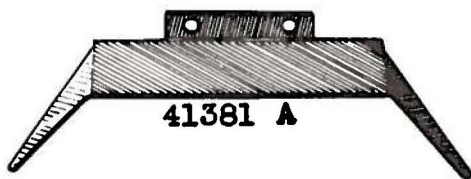

41381 A



423



41375 K



21353 A



21207



9271



21227 M



41375 U



424



105

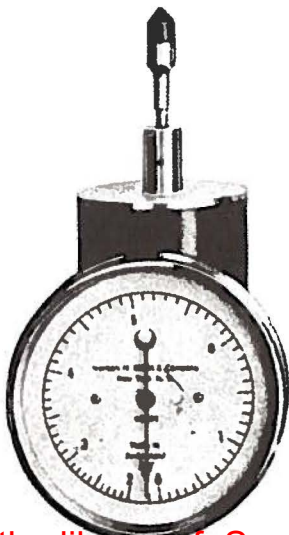

TA55A



21197 F



21209C

Plate 15 - One-Fourth Size



41380



41375



41322E



41380A



41380 P



41380 N

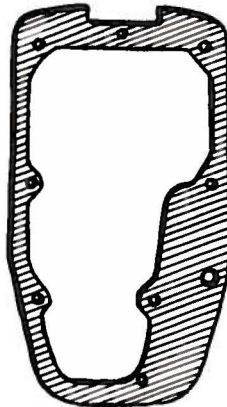

41394B



41375 J



41375 H



41381



21662

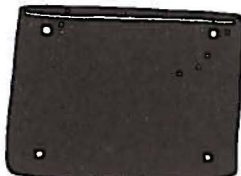

41380 C



422

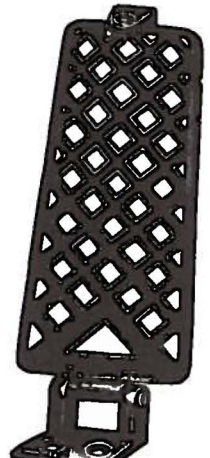

29402

Plate 16 - One-Fourth Size

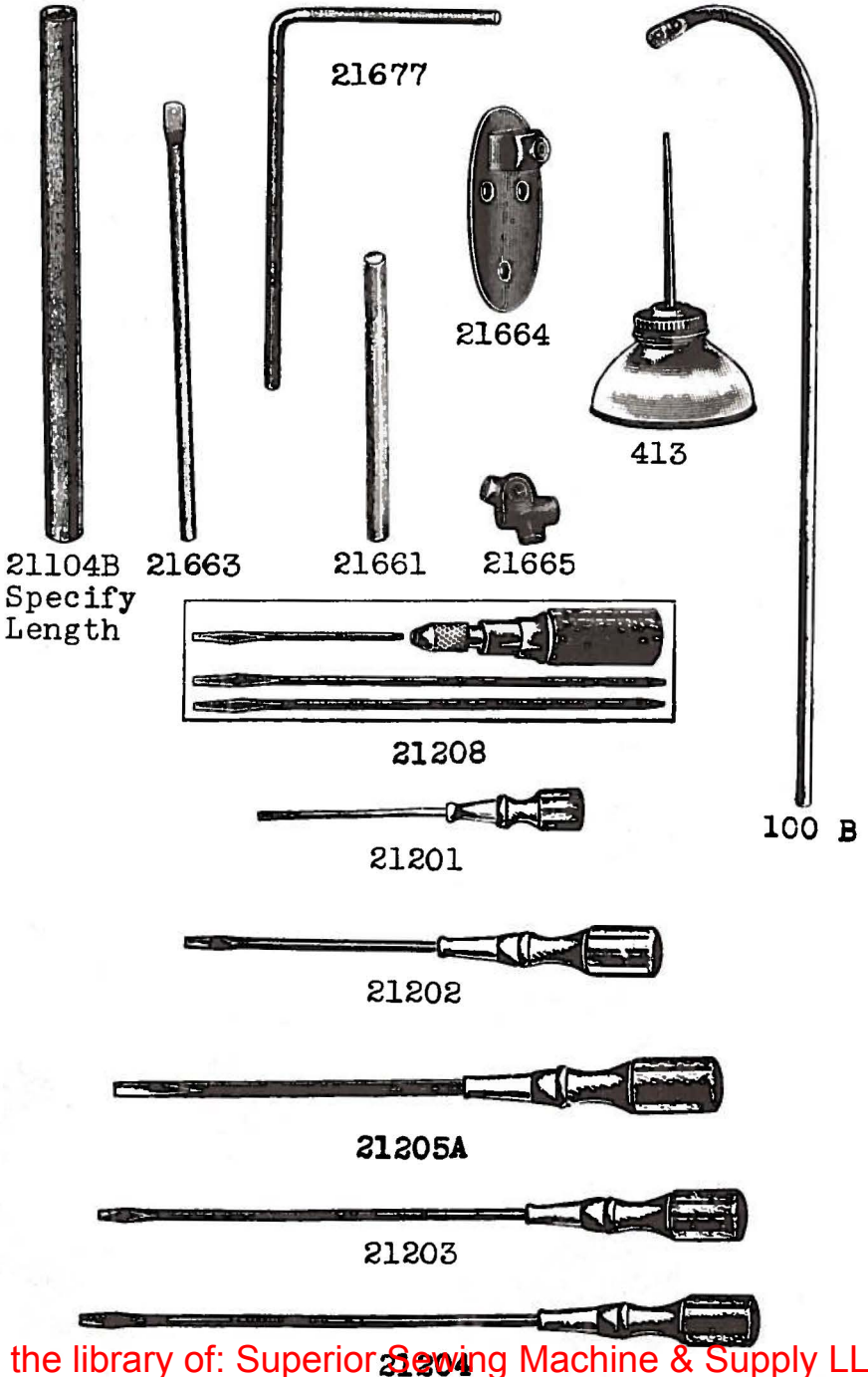
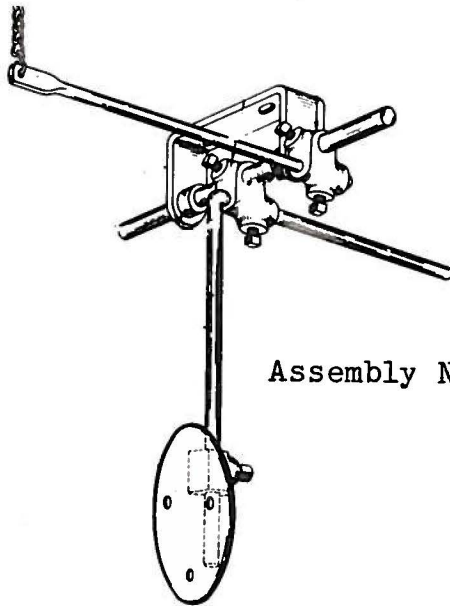
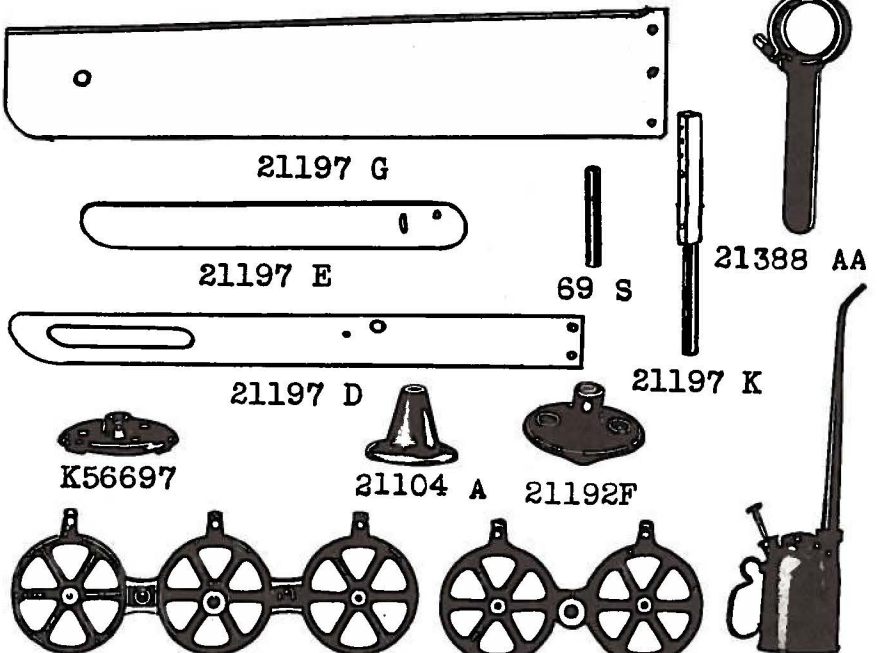

Plate 17 - One-Fourth Size



Assembly No. 21691A

One-Eighth Size



LIST OF PARTS

| Symbol to Order By | The figures in the last column refer only to the plates illustrating the parts and are not to be used in ordering. Prices furnished on application. | Plate No. |
|--------------------------|--|--------------|
| WA15 A | Stop Watch - - - - - | 2 |
| 18 | Nut, right thread, for spreader and back loop- er eccentric connecting rod; also for Nos. 41331 G, 41357 G - - - - - | 2 |
| OI-19 | Pressure Pump Oil Can, 1 1/2 pints capacity- - | 17 |
| C41 | Pivot Stud, for retractable fabric puller and chain cutting knife- - - - - | 2 |
| 50-216 | Dowel Pin, for oil distributing disc - - - - - | 2 |
| TA54 | Hand Tally - - - - - | 14 |
| TA55 A | Hand Tachometer, 300 to 12000 R.P.M. - - - - - | 14 |
| 57 WB | Needle Thread Auxiliary Tension Plate, for Styles 41300 A, 41300 B, 41300 C, 41300 D, 41300 E, 41300 F, 41300 G, 41300 H, 41300 J, 41300 T, 41300 U, 41300 W- - - - - | 5 |
| 57 WC | Needle Thread Auxiliary Tension Spring - - - - - | 3 |
| 57 WD | Needle Thread Auxiliary Tension Spring Stud- - | 1 |
| 69 S | Spool Pin, 4 inches long, for thread stand - - | 17 |
| 69 FD | Set Screw, square head, cup point, 5/16 inch diameter, 18 threads to inch, 5/8 inch long, for thread stand seat; also for Nos. 21663, 21664, 21665 - - - - - | 2 |
| 75 | Screw, for cast iron top cover - - - - - | 1 |
| 77 | Set Screw, for needle bar link pin; also for Nos. 41336 C, 41343 C- - - - - | 1 |
| 79 | Screw, for crank shaft bearing housing - - - - - | 1 |
| IA81 | Spot Screw, for front feed cup pivot shaft bracket- - - - - | 1 |
| 87 U | Screw, for frame looper thread eyelet on Styles 41300 A, 41300 B, 41300 E, 41300 F, 41300 G, 41300 T, 41300 U, 41300 W; also for No. 41358 D- - - - - | 1 |
| 88 | Screw, for looper lever shaft and stitch regulator shaft collar; also for Nos. 21113 B, 41362, 41362 A- - - - - | 1 |
| 89 | Screw, for front fabric uncurler ratchet - - - | 1 |
| 90 | Screw, for needle thread and looper thread eyelet on Styles 41300 M, 41300 N, 41300 P, 41300 Q, 41300 R, 41300 S, 41300 T, 41300 V; also for No. 41376 B - - - - - | 1 |
| 93 | Screw, for wale guide blade on Style 41300 E; also for No. 41370 AB- - - - - | 1 |
| 93 A | Screw, for oil spray deflector plate - - - - - | 1 |
| 94 | Screw, for stitch tongue support - - - - - | 1 |
| 95 | Lock Screw, for front feed cup adjusting stud; also for Nos. 41336 D, 41361 G - - - - - | 1 |
| 96 | Spot Screw, for pulley; also for No. 21193 F - | 1 |
| 96 A | Spot Screw, for oscillating counterweight eccentric on Styles 41300 E, 41300 F, 41300 G, 41300 H, 41300 J, 41300 M, 41300 N, 41300 P, 41300 Q, 41300 R, 41300 S, 41300 T, 41300 U, 41300 V, 41300 W- - - - - | 1 |

LIST OF PARTS

| Symbol to Order By | The figures in the last column refer only to the plates illustrating the parts and are not to be used in ordering. Prices furnished on application. | Plate No. |
|--------------------|---|-----------|
| 97 A | Bearing Screw, front, for feed eccentric assembly; also for Nos. 41332 F, 41342 F, 41355 K- | 2 |
| 98 | Set Screw, for pulley; also for Nos. 2339 F, 9271 | 1 |
| 100 B | Thread Stand Wire, 16 inches long (screw No. 22632 F-24) | 16 |
| 105-4 | Machine Mounting Screw, four inches long | 14 |
| 109 | Tension Disc | 5 |
| 115 | Wrench, single end, light duty, for connecting rod nut- | 13 |
| 118 B | Thread Tweezers- | 13 |
| 134 | Stud, for pivoted blade on wale guide assembly No. 21197 Q | 2 |
| 138 | Screw, for fabric pulling plate- | 1 |
| 258 A | Nut, for feed eccentric assembly | 2 |
| 269 | Nut, left thread, for spreader and back looper eccentric connecting rod; also for Nos. 41331 G, 41357 G- | 2 |
| 318 | Attaching Screw, for fabric uncurler support mounting bracket on all machines except Style 41300 E- | 1 |
| 413 | Oil Can, complete- | 16 |
| 421 C-10 | Feed Cup Separating Chain, upper, 10 inches long | 13 |
| 421 C-18 | Uncurler Shifting Device Chain, 18 inches long | 13 |
| 421 C-34 | Feed Cup Separating Chain, lower, 34 inches long | 13 |
| 422 | Feed Cup Separating Treadle- | 15 |
| 423 | Feed Cup Separating Treadle Base | 14 |
| 424 | Feed Cup Separating Treadle Pin (screw No. 22813) | 14 |
| 454 A | Washer, for stitch regulator adjusting nut | 2 |
| 531 | Set Screw, for feed cup driving gear | 1 |
| 562 | Lock Screw, for machine mounting screw | 2 |
| 605 A | Attaching Screw, for needle holder; also for Nos. 41381, 41381 C- | 1 |
| 660-92 | Washer, leather, 3/16 inch hole, for top of glass tube in oil level gauge- | 2 |
| 660-93 | Washer, leather, 1/4 inch hole, for bottom of glass tube in oil level gauge | 2 |
| 660-142 | Feed Cup Separating Lever Cotter Pin | 4 |
| 660-156 | Machine Mounting Screw Felt Washer | 14 |
| 660-193 | Terminal, for retractable fabric puller and chain cutting knife assembly | 3 |
| 660-204 | Pulley Oil Seal Ring | 3 |
| 666-80 | Glass Tube, for oil level gauge- | 3 |
| 668-25 | Steel Insert, for needle and looper thread tension eyelet assemblies- | 5 |
| 668-26 | Steel Insert, for thread ratio control frame eyelet; also for No. 41332 R | 5 |

LIST OF PARTS

| Symbol to Order By | The figures in the last column refer only to the plates illustrating the parts and are not to be used in ordering. Prices furnished on application. | Plate No. |
|--------------------------|--|--------------|
| 668-28 | Steel Insert Locking Ring, for needle and looper thread tension eyelet assemblies; also for Nos. 41332 R, 41378 - - - - - | 2 |
| 907 | Nut, for oil distributing plate screw- - - - - | 2 |
| 1286 A | Looper Lever Link Pin (set screw No. 22768)- | 3 |
| 2339 F | Wale Guide Rod Collar, for assemblies Nos. 21197 P, 21197 Q (screw No. 98)- - - - - | 4 |
| 6258 | Spring, for fabric uncurler support sliding arm, on Styles 41300 P, 41300 Q, 41300 R, 41300 S, 41300 T, 41300 U, 41300 V, 41300 W | 3 |
| 6956 C | Spring, for machine mounting screw locking pin- - - - - | 3 |
| 6990 | Spring, for fabric uncurler support sliding arm adjustment stud locking ball on Styles 41300 P, 41300 Q, 41300 R, 41300 S, 41300 T, 41300 U, 41300 V, 41300 W - - - - - | 3 |
| 9271 | Collar, for knee press bracket shaft (screw No. 98)- - - - - | 14 |
| 12538 | Nut, for feed clutch driving lever ball joint; also for Nos. 22888, 41367 L- - - - - | 2 |
| 12964 C | Locking Ball, for fabric uncurler support sliding arm adjustment stud on Styles 41300 P, 41300 Q, 41300 R, 41300 S, 41300 T, 41300 U, 41300 V, 41300 W - - - - - | 2 |
| 21104 A | Thread Stand Base- - - - - | 17 |
| 21104 B-9 | Thread Stand Rod, 9 inches long (screw No. 22509) - - - - - | 16 |
| 21113 A | Thread Stand Wire Extension (screw No. 22632 F-24)- - - - - | 9 |
| 21113 B | Thread Stand Wire Coupling (screw No. 88)- - | 4 |
| 21130 A-2 | Thread Stand Seat, two spools (set screw No. 69 FD) - - - - - | 17 |
| 21130 A-3 | Thread Stand Seat, three spools (set screw No. 69 FD) - - - - - | 17 |
| 21192 F | Wale Guide Base, lower, for assemblies Nos. 21197 P, 21197 Q (screw No. 96) - - - - - | 17 |
| 21197 D | Wale Guide Stationary Blade, for assembly No. 21197 Q (screw No. 93) - - - - - | 17 |
| 21197 E | Wale Guide Pivoted Blade, for assembly No. - 21197 Q; (stud No. 134)- - - - - | 17 |
| 21197 F | Wale Guide Pivoted Blade Lifter- - - - - | 14 |
| 21197 G | Wale Guide Blade, for assembly No. 21197 P (screw No. 93) - - - - - | 17 |
| 21197 K | Wale Guide Rod, for assemblies Nos. 21197 P, 21197 Q- - - - - | 17 |
| 21197 P | Wale Guide Assembly, for Style 41300 E; one each Nos. 98, 2339 F, 21192 F, 21197 G, 21197 K, K56697; three No. 93- - - - - | — |
| 21197 Q | Wale Guide Assembly, with adjustable blade, for Style 41300 E; one each Nos. 98, 134, 2339 F, 21192 F, 21197 D, 21197 E, 21197 F, 21197 K, K56697; two No. 93- - - - - | — |

LIST OF PARTS

| Symbol to Order By | The figures in the last column refer only to the plates illustrating the parts and are not to be used in ordering. Prices furnished on application. | Plate No. |
|--------------------------|--|--------------|
| 21201 | Screw Driver, 9/64 inch round blade, length overall 7 5/8 inches - - - - - | 16 |
| 21202 | Screw Driver, 7/32 inch round blade, length overall 11 1/4 inches- - - - - | 16 |
| 21203 | Screw Driver, 13/64 inch round blade, length overall 15 1/2 inches- - - - - | 16 |
| 21204 | Screw Driver, 9/32 inch round blade, length overall 15 inches- - - - - | 16 |
| 21205 A | Screw Driver, 3/8 inch round blade, length overall 14 inches- - - - - | 16 |
| 21207 | Screw Driver, 7/64 inch round blade, length overall 2 1/2 inches - - - - - | 14 |
| 21208 | Screw Driver Set, three detachable blades- - | 16 |
| 21209 C | Off-Set Screw Driver, for needle guard screws - - - - - | 14 |
| 21225 D | Front Looper Timing Gauge, for rocking motion | 13 |
| 21227 L | Gauge, for setting height of feed cup with respect to needle bar- - - - - | 13 |
| 21227 M | Gauge, for maximum space between feed cups - | 14 |
| 21227 NA | Gauge, for setting height of spreader No. 41340 A or back looper No. 41309 A at extreme high position- - - - - | 3 |
| 21227 QA | Gauge, for setting needle and front looper with respect to each other on machines equipped with looper No. 41308 B - - - - - | 2 |
| 21227 WA | Set of Gauges, packed in a leather case; one each Nos. 21225 D, 21227 L, 21227 M, 21227 NA, 21227 QA - - - - - | — |
| 21231 | Thread Meter, for recording the consumption of thread in yards as it passes into the sewing machine - - - - - | — |
| 21260 | Emery Cord, 3/64 inch diameter, grade No. 120, fifty yard spool- - - - - | — |
| 21260 A | Emery Cord, 3/64 inch diameter, grade No. 150, fifty yard spool- - - - - | — |
| 21260 B | Emery Cord, 1/32 inch diameter, grade No. 180, fifty yard spool- - - - - | — |
| 21260 C | Emery Cord, .025 inch diameter, grade No. 200, fifty yard spool- - - - - | — |
| 21260 D | Emery Tape, 3/32 inch wide, grade No. 180, fifty yard spool - - - - - | — |
| 21260 E | Emery Cord, .018 inch diameter, grade No. 200, fifty yard spool- - - - - | — |
| 21261 | Leather Belt, flat, 1 inch wide, 63 inches long, includes belt fastener No. 21350 - - | — |
| 21262 E-56 | Leather Belt, round, 1/4 inch diameter, 56 inches long, includes wire belt hook No. 21351 B - - - - - | — |
| 21350 | Belt Fastener, malleable iron, for 1 inch flat belt- - - - - | 5 |
| 21351 B | Belt Hook, wire, for 1/4 inch round belt - - | 5 |

LIST OF PARTS

| Symbol to Order By | The figures in the last column refer only to the plates illustrating the parts and are not to be used in ordering. Prices furnished on application. | Plate No. |
|--------------------------|--|--------------|
| 21353 A | Steel Washer, for machine mounting screw - - | 14 |
| 21388 | Wrench, single end, heavy duty, 3/8 inch opening- - - - - | 13 |
| 21388 D | Alligator Wrench, for connecting rods- - - - | 13 |
| 21388 N | Wrench, double end, 3/16 and 5/16 inch openings - - - - - | 13 |
| 21388 R | Wrench, double end, 3/8 and 1/2 inch openings - - - - - | 13 |
| 21388 AA | Wrench, for crankshaft bearing housing - - - | 17 |
| 21394 | Utility Grinder, including emery wheel, 5 inch diameter, 1/4 inch face, round belt drive, recommended speed 3000 R.P.M. - - - | — |
| 21394 G | Emery Wheel, 5 inch diameter, 1/4 inch face, 3/8 inch hole, grade "M" emery 60- - - - | — |
| 21394 H | Emery Wheel, 5 inch diameter, 1/2 inch face, 3/8 inch hole, grade "M" emery 60- - - - | — |
| 21394 K | Utility Grinder, including emery wheel, 5 inch diameter, 1/2 inch face, round belt drive, recommended speed 3000 R.P.M. - - - | — |
| 21661 | Knee Press Bracket Shaft - - - - - | 16 |
| 21662 | Knee Press Bracket - - - - - | 15 |
| 21663 | Knee Press Rod, 9 1/8 inches long (screw No. 69 FD) - - - - - | 16 |
| 21664 | Knee Press Plate (screw No. 69 FD) - - - - | 16 |
| 21665 | Knee Press Rod Connection (screw No. 69 FD)- | 16 |
| 21677 | Knee Press Plate Rod - - - - - | 16 |
| 21691 A | Knee Press Assembly; one each Nos. 421 C-18, 21661, 21662, 21663, 21664, 21677; two each Nos. 9271, 21665 (specify component parts when ordering) - - - - - | 17 |
| 21756 G | Fabric Uncurler Support Sliding Arm Operating Stud, for Styles 41300 P, 41300 Q, 41300 R, 41300 S, 41300 T, 41300 U, 41300 V, 41300 W | 2 |
| 22504 A | Screw, for fabric uncurler ratchet pawl - - - | 2 |
| 22509 | Set Screw, for thread stand rod - - - - | 2 |
| 22516 A | Screw, for front feed cup shaft, lower section; also for Nos. 41363 A, 41380, 41380 G, 41381 A - - - - - | 1 |
| 22517 | Clamp Screw, for front feed cup pivot shaft bracket; also for No. 41361 U- - - - - | 1 |
| 22533 | Set Screw, for rear feed cup shaft bushing - | 2 |
| 22537 | Screw, for upper front feed cup shaft bushing- - - - - | 1 |
| 22539 D | Plug Screw, headless, 7/8 inch diameter, for left side of bed - - - - - | 1 |
| 22539 E | Plug Screw, headless, 9/16 inch diameter, for right, left and rear of bed; also for No. 41335 A- - - - - | 1 |
| 22547 A | Screw, for looper needle guard - - - - - | 2 |
| 22548 | Screw, for stitch tongue support upper bracket; also for No. 41370 B- - - - - | 1 |

LIST OF PARTS

| Symbol to Order By | The figures in the last column refer only to the plates illustrating the parts and are not to be used in ordering. Prices furnished on application. | Plate No. |
|--------------------------|---|--------------|
| 22557 | Stud, for fabric uncurler support sliding arm operating lever on Styles 41300 P, 41300 Q, 41300 R, 41300 S, 41300 T, 41300 U, 41300 V, 41300 W - - - - - | 2 |
| 22559 D | Bearing Screw, for looper lever connecting rod assembly; also for needle bar connect- ing rod - - - - - | 1 |
| 22560 B | Set Screw, for clutch driving eccentric bear- ing; also for Nos. 29126 AM, 29126 AN - - - | 1 |
| 22562 | Screw, for back looper and spreader; also for No. 41370 AF - - - - - | 1 |
| 22565 | Screw, for front looper - - - - - | 1 |
| 22565 C | Screw, for pulley rim - - - - - | 1 |
| 22568 | Adjusting Screw, for fabric uncurler mounting bracket on Styles 41300 A, 41300 B, 41300 C, 41300 D, 41300 F, 41300 G, 41300 H, 41300 J, 41300 K, 41300 L, 41300 M, 41300 N - - - - | 2 |
| 22570 A | Screw, for stitch tongue support intermediate bracket; also for Nos. 29450 M, 41367 L, 41383, 41383 C, 41383 D, 41383 E, K60161- - | 1 |
| 22572 | Screw, for fabric uncurler support sliding arm stop on Styles 41300 P, 41300 Q, 41300 R, 41300 S, 41300 T, 41300 U, 41300 V, 41300 W - - - - - | 1 |
| 22584 | Set Screw, for needle bar; also for No. 41375 F - - - - - | 1 |
| 22585 | Clamp Screw, for front looper bar connection collar; also for Nos. 41370 AC, 41367 L - - | 1 |
| 22585 A | Screw, for frame thread eyelet on Styles 41300 C, 41300 D, 41300 H, 41300 J - - - - | 1 |
| 22585 C | Screw, for stationary needle guard - - - - - | 1 |
| 22587 E | Bearing Screw, rear, for feed eccentric assembly; also for Nos. 29126 AM, 29126 AN- | 2 |
| 22591 | Set Screw, for front feed cup pivot shaft bracket - - - - - | 1 |
| 22597 A | Set Screw, for feed clutch housing- - - - - | 1 |
| 22597 B | Spot Screw, for feed clutch housing on mach- ines equipped with constand wedge angle clutch- - - - - | 1 |
| 22597 E | Screw, for attaching upper bracket of retractable fabric puller and chain cutting knife - - - - - | 1 |
| 22632 F-24 | Set Screw, for thread stand wire- - - - - | 2 |
| 22707 A | Screw, for feed clutch compensator spring - - | 1 |
| 22733 B | Plug Screw, fillister head, for needle bar adjusting screw hole (gasket No. 41394 A, washer No. 41394 G) - - - - - | 1 |
| 22738 | Set Screw, for needle - - - - - | 1 |
| 22738 B | Set Screw, for uncurler - - - - - | 1 |
| 22743 | Screw, for rear feed cup shaft collar; also for Nos. 41332 P, 41332 R, 41363, 41363 A - | 1 |

LIST OF PARTS

| Symbol to Order By | The figures in the last column refer only to the plates illustrating the parts and are not to be used in ordering. Prices furnished on application. | Plate No. |
|--------------------------|---|--------------|
| 22747 | Screw, for ball joint forks; also for Nos. 41258 B, 41258 E, 41358 N, 41358 P - - - - | 1 |
| 22760 | Screw, for upper cable attaching lug on retractable fabric puller and chain cutting knife- - - - - | 1 |
| 22764 | Screw, for uncurler support sliding arm adjustment stud locking ball on Styles 41300 P, 41300 Q, 41300 R, 41300 S, 41300 T, 41300 U, 41300 V, 41300 W - - - - | 1 |
| 22764 A | Set Screw, for front feed cup adjusting eccentric collar; also for Nos. 29126 AL, 29126 AM, 29126 AN, 41335 A- - - - - | 1 |
| 22768 | Set Screw, for looper lever link pin - - - - | 1 |
| 22798 A | Screw, for stitch tongue - - - - - | 1 |
| 22799 N | Locking Screw, for thread ratio control tension sleeve - - - - - | 1 |
| 22813 | Set Screw, for feed cup separating treadle pin; also for No. K56697 - - - - - | 1 |
| 22830 | Screw, for fabric uncurler support bracket - | 1 |
| 22849 | Screw, for feed cup separating mechanism cover- - - - - | 2 |
| 22852 | Screw, for oscillating counterweight - - - - | 2 |
| 22888 | Screw, for looper lever on machines equipped with oscillating counterweight - - - - - | 2 |
| 28606-1/2 | Powdered Oil Stone, 1/2 lb. package- - - - - | |
| 28606-1 | Powdered Oil Stone, 1 lb. package- - - - - | |
| *29126 AL | Feed Eccentric Assembly; includes eccentric No. 41357 A (set screw No. 22560 B, spot screw No. 22764 A, bearing screw, rear, No. 22587 E, bearing screw, front, No. 97 A, nut No. 258 A, washer No. 35746 A, shim No. 41355 U) - - - - - | 11 |
| *29126 AM | Spreader and Back Looper Eccentric Assembly; includes eccentric No. 41341 (set screw No. 22560 B, spot screw No. 22764 A, bearing screw No. 22587 E) - - - - - | 11 |
| *29126 AN | Looper Rocking Motion Eccentric Assembly; includes eccentric No. 41331 (set screw No. 22560 B, spot screw No. 22764 A, bearing screw No. 22587 E) - - - - - | 11 |
| 29133 G | Oscillating Counterweight Eccentric Assembly, for Styles 41300 E, 41300 F, 41300 G, 41300 H, 41300 J, 41300 M, 41300 N, 41300 P, 41300 Q, 41300 R, 41300 S, 41300 T, 41300 U, 41300 V, 41300 W; one each Nos. 41336 B, 41336 D - - - - - | 11 |
| 29402 | Feed Cup Separating Treadle Assembly; one each Nos. 422, 423, 424, 22813 - - - - - | 15 |
| *29450 M | Fabric Uncurler Assembly (attaching screw No. 22570 A, uncurler set screws No. 22738 B, guide pin No. 41274, guide pin nut No. 41274 A, spring No. 41370 C) - - - - - | 12 |

LIST OF PARTS

| Symbol to Order By | The figures in the last column refer only to the plates illustrating the parts and are not to be used in ordering. Prices furnished on application. | Plate No. |
|--------------------|---|-----------|
| 29467 B | Feed Cup Driving Gear Assembly, for adding clutch compensator feature to old style clutches; one each Nos. 41258 E, 41357 B, 41358 A, 41358 B, 41365 A; two each No. 22707 A; three each Nos. 87 U, 22747; six each Nos. 41358 C, 41358 D - - - - - | 12 |
| 29478 F | Spreader and Back Looper Eccentric Connecting Rod Assembly; one each Nos. 29126 AM, 18, 269, 22747, 41037 A, 41342 F, 41342 H. Assembly is set to gauge before shipment. The approximate distance between centers is 2 5/8 inches- - - - - | 11 |
| 29478 G | Looper Rocking Motion Eccentric Connecting Rod Assembly; one each Nos. 29126 AN, 18, 50-216, 269, 22747, 41331 G, 41332 F, 41332 H, 41381; two No. 605 A. Assembly is set to gauge before shipment. The approximate distance between centers is 3 23/64 inches - - - - - | 11 |
| 29478 P | Fabric Uncurler Mounting Bracket Assembly; one each Nos. 22504 A, 22548, 22568, 41370 A, 41370 B, 41370 G, 41370 H, 41370 N, 41370 P, 41370 U, 41370 V - - - - | 10 |
| 29478 R | Fabric Uncurler Mounting Bracket Assembly, for knee controlled adjustment of uncurler; one each Nos. 318, 6258, 6990, 12964 C, 21756 G, 22504 A, 22557, 22562, 22572, 22764, 41370 A, 41370 H, 41370 N, 41370 P, 41370 U, 41370 V, 41370 AA, 41370 AB, 41370 AC, 41370 AD, 41370 AE, 41370 AF, 41370 AG, 41370 AH; two No. 22585; for Styles 41300 P, 41300 Q, 41300 R, 41300 S, 41300 T, 41300 U, 41300 V, 41300 W - - - - | — |
| 29478 AU | Feed Clutch Driving Lever Connecting Rod Assembly, for machines equipped with flat surface clutch blocks; one each Nos. 18, 269, 12538, 35746 A, 41355 K, 41357 B, 41357 G, 41357 J. Assembly is set to gauge before shipment. The approximate distance between centers is 4 21/64 inches- - - - - | 11 |
| 29478 BB | Looper Rocking Motion Eccentric Connecting Rod Assembly, for machines equipped with oscillating counterweight; one each Nos. 29126 AN, 18, 50-216, 269, 22747, 41331 G, 41332 F, 41332 H, 41381 C; two No. 605 A. Assembly is set to gauge before shipment. The approximate distance between centers is 3 23/64 inches- - - - - | 11 |

LIST OF PARTS

| Symbol to Order By | The figures in the last column refer only to the plates illustrating the parts and are not to be used in ordering. Prices furnished on application. | Plate No. |
|--------------------------|---|--------------|
| 29478 BM | Feed Clutch Driving Lever Connecting Rod Assembly, for machines equipped with constant wedge angle clutch; one each Nos. 18, 269, 12538, 35746 A, 41355 K, 41355 U, 41357 C, 41357 G, 41357 J. Assembly is set to gauge before shipment. The approximate distance between centers is 4 21/64 inches - | 11 |
| 29478 BN | Constant Wedge Angle Feed Clutch Assembly; one each Nos. 29478 BM, 41358 B, 41358 M, 41358 N, 41358 P, 41358 R, 41358 U, 41363 J, 41363 U, 41364 J, 41365 B; two each Nos. 22707 A, 41350 W; three No. 22597 B; six each Nos, 22747, 41258, 41358 Q, 41358 S, 41358 T- - - - - | 11 |
| 29478 BP | Feed Clutch Assembly, to convert machines with old style clutches to constant wedge angle clutch; one each Nos. 41357 C, 41358 B, 41358 M, 41358 N, 41358 P, 41358 R, 41358 U, 41363 J, 41363 U, 41364 J, 41365 B; two each Nos. 22707 A, 41350 W; three No. 22597 B; six each Nos. 22747, 41258, 41358 Q, 41358 S, 41358 T - - - - - | 12 |
| 29485 C | Thread Ratio Control, complete, for three end stitch on Styles 41300 M, 41300 N, 41300 P, 41300 Q, 41300 R, 41300 S, 41300 T, 41300 V, 41300 W; one each Nos. 22799 N, 39157 K, 41376 G; 41378, 41378 B-64, 41378 C, 41378 D, 41378 E, 41378 F, 41378 J, 41378 Q, 41378 S, 41378 T-56, 41378 U-64, 51242 M, 51292 C, 51292 F-2; two each Nos. 90, 41378 K, 43266; four No. 41378 R; six No. 109 - - - - | 8 |
| 33174 B | Set Screw, for looper and spreader bars- - - - | 1 |
| 35549 | Tension Spring, .026 inch diameter wire for Styles 41300 A, 41300 B, 41300 C, 41300 D, 41300 E, 41300 F, 41300 G, 41300 H, 41300 J, 41300 T, 41300 U, 41300 W - - - - - | 3 |
| 35746 A | Feed Clutch Driving Lever Ball Joint Washer; also for No. 29126 AL- - - - - | 2 |
| 39121 | Pulley, grooved for round belt (spot screw No. 96, set screw No. 98)- - - - - | 12 |
| 39147 D | Looper Lever Shaft and Stitch Regulator Lever Shaft Collar (screw No. 88)- - - - - | 4 |
| 39157 K | Regulating Nut, for thread ratio control ten- sion sleeve on Styles 41300 M, 41300 N, 41300 P, 41300 Q, 41300 R, 41300 S, 41300 T, 41300 V, 41300 W - - - - - | 2 |
| 39193 B | Oil Level Gauge Base - - - - - | 3 |
| 41037 A | Spreader and Back Looper Eccentric Connecting Rod (nut, right thread No. 18, nut, left thread No. 269)- - - - - | 4 |

LIST OF PARTS

| Symbol to Order By | The figures in the last column refer only to the plates illustrating the parts and are not to be used in ordering. Prices furnished on application. | Plate No. |
|--------------------------|--|--------------|
| 41039 A | Front Looper Bar Connection Collar (screw No. 22585) - - - - - | 4 |
| 41071 G | Nut, for lower cable attaching screw on retractable fabric puller and chain cutting knife- - - - - | 2 |
| 41258 | Feed Clutch Roller - - - - - | 4 |
| 41258 A | Feed Clutch Roller Torsion Spring, for machines equipped with flat surface clutch blocks (screw No. 87 U)- - - - - | 3 |
| 41258 B | Feed Clutch Triangular Block, lower, with flat surface (screw No. 22747) - - - - - | 7 |
| 41258 D | Feed Clutch Housing, for machines equipped with flat surface clutch blocks (screw No. 22597 B) - - - - - | 12 |
| 41258 E | Feed Clutch Triangular Block, upper, with flat surface (screw No. 22747) - - - - - | 7 |
| 41274 | Fabric Uncurler Guide Pin- - - - - | 2 |
| 41274 A | Fabric Uncurler Guide Pin Nut- - - - - | 2 |
| 41298-5 | Shim, .005 inch thick, for increasing height of stitch tongue - - - - - | 5 |
| 41308 B | Looper, front (screw No. 22565)- - - - - | 6 |
| 41309 A | Looper, rear, for Styles 41300 C, 41300 D, 41300 H, 41300 J, 41300 M, 41300 N, 41300 P, 41300 Q, 41300 R, 41300 S, 41300 T, 41300 V, 41300 W; (screw No.22562) | 6 |
| 41310 | Looper Needle Guard (screw No. 22547 A)- - - | 6 |
| 41317 | Needle Bar (set screw No. 22584) - - - - - | 9 |
| 41318 A | Needle Holder (attaching screw No. 605 A, needle set screw No. 22738)- - - - - | 6 |
| 41321 | Pulley, grooved for No. 1 "V" belt (spot screw No. 96, set screw No. 98)- - - - - | 12 |
| *41322 E | Crankshaft Assembly; includes crankshaft No. 41322 D- - - - - | 15 |
| 41325 D | Stationary Needle Guard, with .055 inch step, for use with stitch tongue support No. 41366 C- - - - - | 6 |
| 41325 E | Stationary Needle Guard, with .040 inch step, for use with stitch tongue support No. 41366 D- - - - - | 6 |
| 41325 F | Stationary Needle Guard, with .065 inch step, for use with stitch tongue support No. 41366 E- - - - - | 6 |
| 41331 G | Stationary Needle Guard Screw No. 22585 C Looper Rocking Motion Eccentric Connecting Rod (nut, right thread No. 18, nut, left thread No. 269)- - - - - | 9 |
| 41332 | Front Looper Bar (set screw No. 33174 B) - - - | 9 |
| 41332 A | Front Bushing, for front looper bar- - - - - | 4 |
| 41332 B | Rear Bushing, for front looper bar - - - - - | 4 |
| 41332 C | Looper Bar Bushing Oil Seal Cap- - - - - | 2 |
| *41332 F | Looper Bar Ball Joint Assembly (bearing screw No. 97 A, looper bar screw No. 33174 B)- - - | 5 |

LIST OF PARTS

| Symbol to Order By | The figures in the last column refer only to the plates illustrating the parts and are not to be used in ordering. Prices furnished on application. | Plate No. |
|--------------------------|--|--------------|
| 41332 H | Front Looper Bar Ball Joint Fork (screw No. 22747) - - - - - | 5 |
| 41332 J | Front Looper Bar Thrust Washer - - - - - | 2 |
| 41332 P | Front Looper Bar Needle Thread Take-up Eyelet Holder (set screw No. 22743)- - - | 4 |
| 41332 R | Front Looper Bar Needle Thread Eyelet, for Styles 41300 A, 41300 B, 41300 C, 41300 D, 41300 E, 41300 G, 41300 K, 41300 L, 41300 M, 41300 N, 41300 R, 41300 S (screw No. 22743)- - - - - | 5 |
| *41335 | Looper Lever, including bushings, for machines without oscillating counterweight - - | 11 |
| 41335 A | Looper Lever Shaft and Stitch Regulator Shaft (screw No. 22764 A, plug screw No.22539 E) | 9 |
| *41335 B | Looper Lever, for machines equipped with oscillating counterweight (screw No.22888) | 10 |
| 41335 N | Looper Lever Link- - - - - | 5 |
| 41335 P | Looper Lever Link Connection - - - - - | 5 |
| *41336 A | Oscillating Counterweight and Lever, complete | 10 |
| 41336 B | Oscillating Counterweight Connection Bearing | 11 |
| 41336 C | Oscillating Counterweight Connection Pin (screw No. 77) - - - - - | 3 |
| 41336 D | Oscillating Counterweight Eccentric (screws Nos. 95, 96 A) - - - - - | 10 |
| 41340 A | Spreader, for Styles 41300 A, 41300 B, 41300 E, 41300 F, 41300 G, 41300 K, 41300 L, 41300 T, 41300 U, 41300 W (screw No. 22562) - - - - - | 6 |
| 41342 | Spreader and Back Looper Bar (set screw No. 33174 B) - - - - - | 9 |
| 41342 A | Bushing, for spreader and back looper bar - | 9 |
| *41342 F | Spreader and Back Looper Connecting Rod Ball Joint Assembly (bearing screw No. 97 A)- - | 5 |
| 41342 H | Spreader and Back Looper Connecting Rod Ball Joint Fork (screw No. 22747) - - - - - | 5 |
| 41343 B | Back Looper Bar and Spreader Bar Thread Eyelet for Styles 41300 F, 41300 G, 41300 H, 41300 J, 41300 M, 41300 N, 41300 P, 41300 Q, 41300 R, 41300 S, 41300 T, 41300 U, 41300 W (screw No. 77) - - - - - | 5 |
| 41343 C | Spreader Bar Eyelet Holder, for needle and looper thread eyelets on Styles 41300 F, 41300 G, 41300 H, 41300 J, 41300 M, 41300 N, 41300 P, 41300 Q, 41300 R, 41300 S, 41300 T, 41300 U, 41300 V, 41300 W (screw No. 77) - - - - - | 4 |
| 41345 G-4 | Shim, .004 inch thick, for stationary needle guard- - - - - | 7 |
| 41345 G-5 | Shim, .005 inch thick- - - - - | 7 |
| 41345 G-6 | Shim, .006 inch thick- - - - - | 7 |
| 41345 G-7 | Shim, .007 inch thick- - - - - | 7 |

LIST OF PARTS

| Symbol to Order By | The figures in the last column refer only to the plates illustrating the parts and are not to be used in ordering. Prices furnished on application. | Plate No. |
|--------------------------|--|--------------|
| 41345 G-8 | Shim, .008 inch thick- - - - - | 7 |
| 41345 G-9 | Shim, .009 inch thick- - - - - | 7 |
| 41350 A | Needle Bar Link (needle bar set screw No. 22584) - - - - - | 5 |
| 41350 G | Needle Bar Link Pin (screw No. 77) - - - - - | 4 |
| 41350 U | Needle Bar Bushing - - - - - | 4 |
| 41350 V | Needle Bar Bushing Oil Seal Cap- - - - - | 4 |
| 41350 W | Needle Bar Bushing Oil Seal Ring; also for lower feed clutch disc on machines equipped with constant wedge angle clutch | 3 |
| 41355 | Stitch Regulator Adjusting Nut (washer No. 454 A) - - - - - | 4 |
| *41355 A | Stitch Regulator Lever, including bushings - | 11 |
| *41355 K | Stitch Regulator Ball Joint- - - - - | 5 |
| 41355 U-004 | Shim, .004 inch thick, for feed eccentric assembly upper bearing - - - - - | 2 |
| 41355 U-005 | Shim, .005 inch thick- - - - - | 2 |
| 41355 U-006 | Shim, .006 inch thick- - - - - | 2 |
| 41355 U-007 | Shim, .007 inch thick- - - - - | 2 |
| 41355 U-008 | Shim, .008 inch thick- - - - - | 2 |
| 41355 U-009 | Shim, .009 inch thick- - - - - | 2 |
| 41357 B | Feed Clutch Driving Lever, for machines equipped with clutch compensator and flat surface clutch blocks- - - - - | 12 |
| 41357 C | Feed Clutch Driving Lever, for machines equipped with constant wedge angle clutch- | 12 |
| 41357 G | Feed Clutch Driving Lever Connecting Rod (nut, right thread No. 18, nut, left thread No. 269)- - - - - | 9 |
| *41357 J | Feed Clutch Driving Lever Ball Joint Assembly (nut No. 12538, washer No. 35746 A) - - - - - | 5 |
| 41357 N | Feed Clutch Housing Bushing, for machines equipped with flat surface clutch blocks - | 4 |
| 41358 | Feed Clutch Spring Washer, for machines equipped with feed clutch roller torsion springs- - - - - | 2 |
| 41358 A | Feed Clutch Compensator Spring Locating Collar and Thrust Bearing, for machines equipped with flat surface clutch blocks - | 7 |
| 41358 B | Feed Clutch Compensator Spring (screw No. 22707 A) - - - - - | 7 |
| 41358 C | Feed Clutch Roller Compression Spring for machines equipped with flat surface clutch blocks - - - - - | 3 |
| 41358 D | Feed Clutch Roller Compression Spring Sup- porting Plate, for machines equipped with flat surface clutch blocks (screw No.87 U) | 7 |
| 41358 M | Feed Clutch Housing, for machines equipped with constant wedge angle clutch (set screw No. 22597 A, spot screw No. 22597 B) | 12 |

LIST OF PARTS

| Symbol to Order By | The figures in the last column refer only to the plates illustrating the parts and are not to be used in ordering. Prices furnished on application. | Plate No. |
|--------------------------|--|--------------|
| 41358 N | Feed Clutch Disc, upper, for machines equipped with constant wedge angle clutch (screw No. 22747) - - - - - | 7 |
| 41358 P | Feed Clutch Disc, lower, for machines equipped with constant wedge angle clutch (screw No. 22747) - - - - - | 7 |
| 41358 Q | Feed Clutch Roller Compression Spring, for machines equipped with constant wedge angle clutch - - - - - | 3 |
| 41358 R | Feed Clutch Compensator Spring Locating Collar and Thrust Bearing, for machines equipped with constant wedge angle clutch- - - - - | 7 |
| 41358 S | Feed Clutch Roller Spring Support Pin, for machines equipped with constant wedge angle clutch - - - - - | 7 |
| 41358 T | Feed Clutch Roller Spring Support Pin Spacing Washer, for machines equipped with constant wedge angle clutch - - - - - | 7 |
| 41358 U | Oil Seal Washer, for lower feed clutch disc on machines equipped with constant wedge angle clutch - - - - - | 2 |
| 41360 | Front Feed Cup Adjusting Stud (lock screw No. 95)- - - - - | 4 |
| 41360 G | Front Feed Cup Adjusting Eccentric Collar (screw No. 22764 A)- - - - - | 4 |
| 41361 | Front Feed Cup Pivot Shaft - - - - - | 9 |
| 41361 G | Front Feed Cup Pivot Shaft Bushing (screw No. 95)- - - - - | 4 |
| 41361 N | Front Feed Cup Pivot Shaft Bracket (spot screw No. HA81, set screw No. 22591, clamp screw No. 22517) - - - - - | 10 |
| 41361 U | Front Feed Cup Separating Lever (screw No. 22517) - - - - - | 11 |
| 41362 | Feed Cup, width of feeding section 5/16 inch (screw No. 88) - - - - - | 10 |
| 41362 A | Feed Cup, width of feeding section 5/32 inch (screw No. 88) - - - - - | 10 |
| 41363 | Front Feed Cup Shaft, lower section (screws No. 22516 A, 22743)- - - - - | 9 |
| 41363 A | Front Feed Cup Shaft, upper section (screws Nos. 22516 A, 22743) - - - - - | 12 |
| 41363 G | Feed Cup Shaft, rear, for machines equipped with flat surface clutch blocks- - - - - | 9 |
| 41363 J | Feed Cup Shaft, rear, for machines equipped with constant wedge angle clutch - - - - - | 12 |
| 41363 N | Front Feed Cup Shaft Floating Connector- - - - - | 4 |
| 41363 U | Rear Feed Cup Shaft Collar (screw No. 22743) | 4 |
| 41364 | Front Feed Cup Shaft Bearing - - - - - | 12 |
| 41364 G | Rear Feed Cup Shaft Bushing, for machines equipped with flat surface clutch blocks (set screw No. 22533)- - - - - | 12 |

LIST OF PARTS

| Symbol to Order By | The figures in the last column refer only to the plates illustrating the parts and are not to be used in ordering. Prices furnished on application. | Plate No. |
|--------------------------|---|--------------|
| 41364 J | Rear Feed Cup Shaft Bushing, for machines equipped with constant wedge angle clutch (screw No. 22533)- - - - - | 12 |
| 41364 N | Upper Front Feed Cup Shaft Bushing (screw No. 22537) - - - - - | 4 |
| 41365 | Feed Cup Driving Gear, front (screw No. 531) | 12 |
| 41365 A | Feed Cup Driving Gear, rear, for machines equipped with flat surface clutch (screw No. 531) - - - - - | 12 |
| 41365 B | Feed Cup Driving Gear, rear, for machines equipped with constant wedge angle clutch (screw No. 531)- - - - - | 12 |
| 41366 C | Stitch Tongue Support, marked "D", with .055 inch step, for use with needle guard No. 41325 D- - - - - | 6 |
| 41366 D | Stitch Tongue Support, marked "E", with .040 inch step, for use with needle guard No. 41325 E- - - - - | 6 |
| 41366 E | Stitch Tongue Support, marked "G", with .065 inch step, for use with needle guard No. 41325 F- - - - - | 6 |
| 41366 G | Stitch Tongue Support Screw No. 94. Stitch Tongue Support Intermediate Bracket (screw No. 22570 A)- - - - - | 7 |
| 41366 N | Stitch Tongue Support Upper Bracket (screw No. 22548) - - - - - | 7 |
| 41367 C | Tension Spring, for retractable fabric puller and chain cutting plate - - - - - | 3 |
| 41367 G | Knife, for retractable fabric puller and chain cutting knife- - - - - | 8 |
| 41367 H | Retractable Fabric Puller and Chain Cutting Knife Assembly; one each Nos. C41, 138, 12538, 22585, 22597 E, 22760, 41071 G, 41367 C, 41367 G, 41367 J, 41367 K, 41367 L, 41380 P; two each Nos. 22570 A, 22849- - - - - | 8 |
| 41367 J | Fabric Pulling Plate (screw No. 138) - - - - - | 8 |
| 41367 K | Fabric Puller Arm- - - - - | 8 |
| 41367 L | Cable Assembly (bracket attaching screw, upper, No. 22597 E, lock nut, No. 12538, screw, lower, No. 22570 A, cable attaching screw, upper, No. 22760, screw lower, No. 22585, nut No. 41071 G)- - - - - | 9 |
| 41367 M | Cable, for retractable fabric puller and chain cutting knife assembly - - - - - | 9 |
| 41370 A | Fabric Uncurler Support Bracket (screw No. 22830) - - - - - | 7 |
| 41370 B | Fabric Uncurler Support Intermediate Bracket, for Styles 41300 A, 41300 B, 41300 C, 41300 D, 41300 F, 41300 G, 41300 H, 41300 J, 41300 K, 41300 L, 41300 M, 41300 N (screw No. 22548)- - - - - | 11 |

LIST OF PARTS

| Symbol to Order By | The figures in the last column refer only to the plates illustrating the parts and are not to be used in ordering. Prices furnished on application. | Plate No. |
|--------------------------|---|--------------|
| 41370 C | Fabric Uncurler Spring - - - - - | 3 |
| 41370 G | Fabric Uncurler Support Mounting Bracket, for Styles 41300 A, 41300 B, 41300 C, 41300 D, 41300 F, 41300 G, 41300 H, 41300 J, 41300 K, 41300 L, 41300 M, 41300 N (attach- ing screw No. 318, adjusting screw No. 22568) - - - - - | 7 |
| 41370 H | Fabric Uncurler Lever - - - - - | 10 |
| 41370 N | Fabric Uncurler Ratchet, front (screw No. 89) | 7 |
| 41370 P | Fabric Uncurler Ratchet, rear - - - - - | 7 |
| 41370 U | Fabric Uncurler Ratchet Pawl (screw No. 22504 A) - - - - - | 7 |
| 41370 V | Fabric Uncurler Ratchet Pawl Spring - - - - - | 3 |
| 41370 AA | Fabric Uncurler Support Mounting Bracket, for knee controlled adjustment of uncurler on Styles 41300 P, 41300 Q, 41300 R, 41300 S, 41300 T, 41300 U, 41300 V, 41300 W (attach- ing screw No. 318) - - - - - | 10 |
| 41370 AB | Fabric Uncurler Support Sliding Arm, for knee controlled adjustment of uncurler on Styles 41300 P, 41300 Q, 41300 R, 41300 S, 41300 T, 41300 U, 41300 V, 41300 W (clamp screw No. 93, operating stud No. 21756 G)- | 10 |
| 41370 AC | Fabric Uncurler Support Sliding Arm Gib, for knee controlled adjustment of uncurler on Styles 41300 P, 41300 Q, 41300 R, 41300 S, 41300 T, 41300 U, 41300 V, 41300 W (screw No. 22585) - - - - - | 7 |
| 41370 AD | Fabric Uncurler Support Sliding Arm Operating Lever, for knee controlled adjustment of uncurler on Styles 41300 P, 41300 Q, 41300 R, 41300 S, 41300 T, 41300 U, 41300 V, 41300 W (pivot stud No. 22557) - - - - - | 10 |
| 41370 AE | Fabric Uncurler Support Sliding Arm Adjust- ment Stud, for knee controlled adjustment of uncurler on Styles 41300 P, 41300 Q, 41300 R, 41300 S, 41300 T, 41300 U, 41300 V, 41300 W (locking ball No. 12964 C, locking ball spring No. 6258)- - - - - | 7 |
| 41370 AF | Fabric Uncurler Support Sliding Arm Adjust- ment Stud Nut, for knee controlled adjust- ment of uncurler on Styles 41300 P, 41300 Q, 41300 R, 41300 S, 41300 T, 41300 U, 41300 V, 41300 W - - - - - | 7 |
| 41370 AG | Fabric Uncurler Support Sliding Arm Stop, for knee controlled adjustment of uncurler on Styles 41300 P, 41300 Q, 41300 R, 41300 S, 41300 T, 41300 U, 41300 V, 41300 W (screw No. 22572) - - - - - | 7 |
| 41370 AH | Fabric Uncurler Ratchet Pawl Arm, for knee controlled adjustment of uncurler - - - - - | 7 |
| 41375 | Feed Cup Separating Rod - - - - - | 15 |

LIST OF PARTS

| Symbol to Order By | The figures in the last column refer only to the plates illustrating the parts and are not to be used in ordering. Prices furnished on application. | Plate No. |
|--------------------------|---|--------------|
| 41375 A | Feed Cup Separating Rod Yoke- - - - - | 3 |
| 41375 F | Feed Cup Separating Rod Collar (screw No. 22584)- - - - - | 4 |
| 41375 G | Feed Cup Separating Rod Yoke Spring - - - - | 3 |
| 41375 H | Feed Cup Separating Lever Assembly, lower; one each Nos. 424, 660-142, 41375 J, 41375 K - - - - - | 15 |
| 41375 J | Feed Cup Separating Lever, lower- - - - - | 15 |
| 41375 K | Feed Cup Separating Lever Bracket - - - - - | 14 |
| 41375 P | Presser Spring Washer - - - - - | 2 |
| 41375 Q | Presser Spring- - - - - | 3 |
| 41375 U | Presser Spring Regulating Screw and Bushing | 14 |
| 41375 V | Presser Spring Regulating Screw Lock Nut- - | 4 |
| 41376 A | Frame Looper Thread Eyelet, for Styles 41300 A, 41300 B, 41300 C, 41300 D, 41300 E, 41300 F, 41300 G, 41300 H, 41300 J, 41300 T, 41300 U, 41300 W (screw No. 87 U)- - - - - | 5 |
| 41376 B | Frame Needle Thread Eyelet, for Styles 41300 A, 41300 B, 41300 C, 41300 D, 41300 E, 41300 G, 41300 H, 41300 J, 41300 U (screw No. 90)- - - - - | 5 |
| 41376 G | Needle Thread and Looper Thread Eyelet, for Styles 41300 M, 41300 N, 41300 P, 41300 Q, 41300 R, 41300 S, 41300 T, 41300 V, 41300 W (screw No. 90) - - - - - | 5 |
| 41377 | Needle Thread Auxiliary Tension Bracket, for Styles 41300 A, 41300 B, 41300 C, 41300 D, 41300 E, 41300 F, 41300 G, 41300 H, 41300 J, 41300 T, 41300 U, 41300 W- - - - - | 10 |
| 41378 | Thread Ratio Control Frame, including insert eyelets on Styles 41300 M, 41300 N, 41300 P, 41300 Q, 41300 R, 41300 S, 41300 T, 41300 V, 41300 W - - - - - | 8 |
| 41378 B-64 | Thread Ratio Control Looper Thread Roller, 1 inch diameter - - - - - | 8 |
| 41378 C | Thread Ratio Control Roller Axle- - - - - | 8 |
| 41378 D | Thread Ratio Control Roller Axle Adapter Stud- - - - - | 8 |
| 41378 E | Thread Ratio Control Tension Sleeve (locking screw No. 22799 N)- - - - - | 8 |
| 41378 F | Thread Ratio Control Tension Spring - - - - | 3 |
| 41378 J | Thread Ratio Control Tension Post (nut No. 43266)- - - - - | 8 |
| 41378 K | Thread Ratio Control Tension Disc Spacing Collar- - - - - | 8 |
| 41378 Q | Thread Ratio Control Clutch Disc- - - - - | 8 |
| 41378 R | Thread Ratio Control Clutch Roller- - - - - | 8 |
| 41378 S | Thread Ratio Control Clutch Roller Retaining Washer- - - - - | 8 |
| 41378 T-56 | Thread Ratio Control Needle Thread Roller, with flange, 7/8 inch diameter- - - - - | 8 |

LIST OF PARTS

| Symbol to Order By | The figures in the last column refer only to the plates illustrating the parts and are not to be used in ordering. Prices furnished on application. | Plate No. |
|--------------------|--|-----------|
| 41378 U-64 | Thread Ratio Control Looper Thread Roller, with flange, 1 inch diameter- - - - - | 8 |
| 41380 | Top Cover, bakelite, including gasket (screw No. 22516 A)- - - - - | 15 |
| 41380 A | Top Cover, cast iron, including gasket (screw No. 75)- - - - - | 15 |
| 41380 G | Rear Cover, including gasket (screw No 22516 A)- - - - - | 15 |
| 41380 N | Cover, for feed cup separating mechanism (screw No. 22849) - - - - - | 15 |
| 41380 P | Cover, for feed cup separating mechanism on machines equipped with retractable fabric puller and chain cutting knife (screw No. 22849) - - - - - | 15 |
| 41381 | Oil Distributing Disc, for machines without oscillating counterweight (screw No. 605 A, dowel pin No. 50-216)- - - - - | 9 |
| 41381 A | Oil Distributing Plate, for machines without oscillating counterweight - - - - - | 14 |
| 41381 C | Oil Distributing Disc, with counterweight, for machine equipped with oscillating counterweight (screw No. 605 A) - - - - - | 9 |
| 41381 G | Oil Spray Deflector Plate (screw No. 93 A)- | 15 |
| 41383 | Chain Cutter, for Styles 41300 A, 41300 B, 41300 C, 41300 D, 41300 E, 41300 F, 41300 G, 41300 H, 41300 J, 41300 K, 41300 L, 41300 M, 41300 N, 41300 P, 41300 Q, 41300 R, 41300 S (screw No. 22570 A) - - - - - | 10 |
| 41383 C | Chain and Needle Guard, for Styles 41300 A, 41300 B, 41300 C, 41300 D, 41300 E, 41300 F, 41300 G, 41300 H, 41300 J, 41300 P, 41300 Q, 41300 R, 41300 S (screw No. 22570 A) - - - - - | 10 |
| 41383 D | Chain and Needle Guard, for Styles 41300 K, 41300 L, 41300 M, 41300 N (screw No. 22570 A)- - - - - | 10 |
| 41383 E | Chain Cutter Extension Plate, for Styles 41300 K, 41300 L, 41300 M, 41300 N (screw No. 22570 A)- - - - - | 3 |
| 41383 F | Selvage Guard (screw No. 22585 C) - - - - - | 6 |
| 41390 | Crankshaft Bushing, right and left, for machines without oscillating counterweight; also left, for machines equipped with oscillating counterweight - - - - - | 4 |
| 41390 A | Crankshaft Bearing Housing, right and left, includes bushing, for machines without oscillating counterweight; also left, for machines equipped with oscillating counterweight (screw No. 79)- - - - - | 10 |
| 41390 B | Crankshaft Bushing, right, for machines equipped with oscillating counterweight - | 4 |

LIST OF PARTS

| Symbol to Order By | The figures in the last column refer only to the plates illustrating the parts and are not to be used in ordering. Prices furnished on application. | Plate No. |
|--------------------------|---|--------------|
| 41390 C | Crankshaft Bearing Housing, right, includes bushing, for machines equipped with oscillating counterweight (screw No. 79) - | 10 |
| 41391 | Crankshaft Thrust Washer - - - - - | 2 |
| 41391 G | Pulley Rim (screw No. 22565 C) - - - - - | 10 |
| 41392 | Tension Post Ferrule, for machines without thread ratio control - - - - - | 5 |
| 41393 | Oil Level Gauge Assembly; one each Nos. 41393 A, 660-92, 660-93, 666-80, 39193 B - | 3 |
| 41393 A | Oil Level Gauge Glass Tube Cover - - - - - | 3 |
| 41394 | Gasket, for crankshaft bearing housing - - - | 10 |
| 41394 A | Gasket, for needle bar adjusting screw hole- | 2 |
| 41394 B | Gasket, for top cover- - - - - | 15 |
| 41394 C | Gasket, for rear cover - - - - - | 13 |
| 41394 D | Gasket, for looper lever shaft hole- - - - - | 3 |
| 41394 G | Washer, for needle bar adjustment screw hole | 2 |
| 41395 | Bed Mounting Shim- - - - - | 10 |
| 41396 | Machine Mounting Screw Locking Pin, brass- | 3 |
| 41397 A | Stitch Tongue, marked "DE", for Styles 41300 B, 41300 D, 41300 G, 41300 J, 41300 Q- - - - - | 6 |
| 41397 B | Stitch Tongue, marked "DF", for Styles 41300 A, 41300 C, 41300 F, 41300 H, 41300 P, 41300 T, 41300 U, 41300 V, 41300 W- - - - - | 6 |
| 41397 D | Stitch Tongue, marked "DG" - - - - - | 6 |
| 41397 E | Stitch Tongue, marked "DH", for Style 41300 E- - - - - | 6 |
| | NOTE: For mock seaming on fine work use No. 41397 D. | |
| 41397 F | Stitch Tongue, marked "DJ", for Styles 41300 K, 41300 L, 41300 M, 41300 N, 41300 R, 41300 S - - - - - | 6 |
| 43266 | Stitch Tongue Screws No. 22798 A. Nut, for thread ratio control tension post, on Styles 41300 M, 41300 N, 41300 P, 41300 Q, 41300 R, 41300 S, 41300 T, 41300 U, 41300 V, 41300 W- - - - - | 2 |
| 51242 M | Washer, for oscillating counterweight screws; also for thread ratio control frame- - - - - | 2 |
| 51292 | Tension Post, for Styles 41300 A, 41300 B, 41300 C, 41300 D, 41300 E, 41300 F, 41300 G, 41300 H, 41300 J, 41300 T, 41300 U, 41300 W - - - - - | 5 |
| 51292 C | Tension Regulating Nut - - - - - | 2 |
| 51292 D | Needle and Looper Thread Tension Eyelet Assembly (steel insert No. 668-25, ferrule No. 668-28)- - - - - | 5 |
| 51292 F-2 | Thread Ratio Control Tension Spring- - - - - | 3 |

LIST OF PARTS

| Symbol to Order By | The figures in the last column refer only to the plates illustrating the parts and are not to be used in ordering. Prices furnished on application. | Plate No. |
|--------------------------|--|--------------|
| K56697 | Wale Guide Base, upper, for assemblies Nos. 21197 P, 21197 Q (screw No. 22813) - - - - | 17 |
| *K60161 | Fabric Uncurler Assembly (attaching screw No. 22570 A, uncurler set screws No. 22738 B, guide pin No. 41274, guide pin nut No. 41274 A, spring No. 41370 C) - - - | 12 |



Union Special[®]
INDUSTRIAL SEWING MACHINES

UNION SPECIAL maintains sales and service facilities throughout the world. These offices will aid you in the selection of the right sewing equipment for your particular operation. Union Special representatives and service men are factory trained and are able to serve your needs promptly and efficiently. Whatever your location, there is a Union Special Representative to serve you. Check with him today.

ATLANTA, GA.

BOSTON, MASS.

CHICAGO, ILL.

DALLAS, TEXAS

LOS ANGELES, CAL.

NEW YORK, N. Y.

PHILADELPHIA, PA.

MONTREAL, QUEBEC

BRUSSELS, BELGIUM

LEICESTER, ENGLAND

LONDON, ENGLAND

PARIS, FRANCE

STUTTART, GERMANY

Representatives and distributors in all important industrial cities throughout the world.

Union Special

MACHINE COMPANY

400 N. FRANKLIN ST., CHICAGO, ILL. 60610

From the library of: Superior Sewing Machine & Supply LLC