



高速平缝机 ZJ8500

HIGH-SPEED LOCKSTITCH SEWING MACHINE

零件手册

PARTS BOOK

中国·中捷缝纫机股份有限公司
ZOJE SEWING MACHINE CO., LTD.

目录

CONTENTS

1. 机壳分组件 Machine frame & miscellaneous cover components.....	28
2. 主轴及挑线杆分组件 Main shaft & thread take-up lever components.....	31
3. 针杆、竖轴及旋梭驱动轴分组件 Needle bar, upright shaft & hook driving shaft components	34
4. 压脚分组件 Presser foot components.....	37
5. 送料分组件 Feed mechanism components.....	39
6. 润滑分组件 Oil lubrication components	43
7. 油盘分组件 Oil reservoir components	45
8. 皮带罩、绕线器与过线架分组件 Belt cover, bobbin winder & thread stand components.....	47
9. 附件 Accessories.....	50

1、机壳分组件 Machine frame & miscellaneous cover components

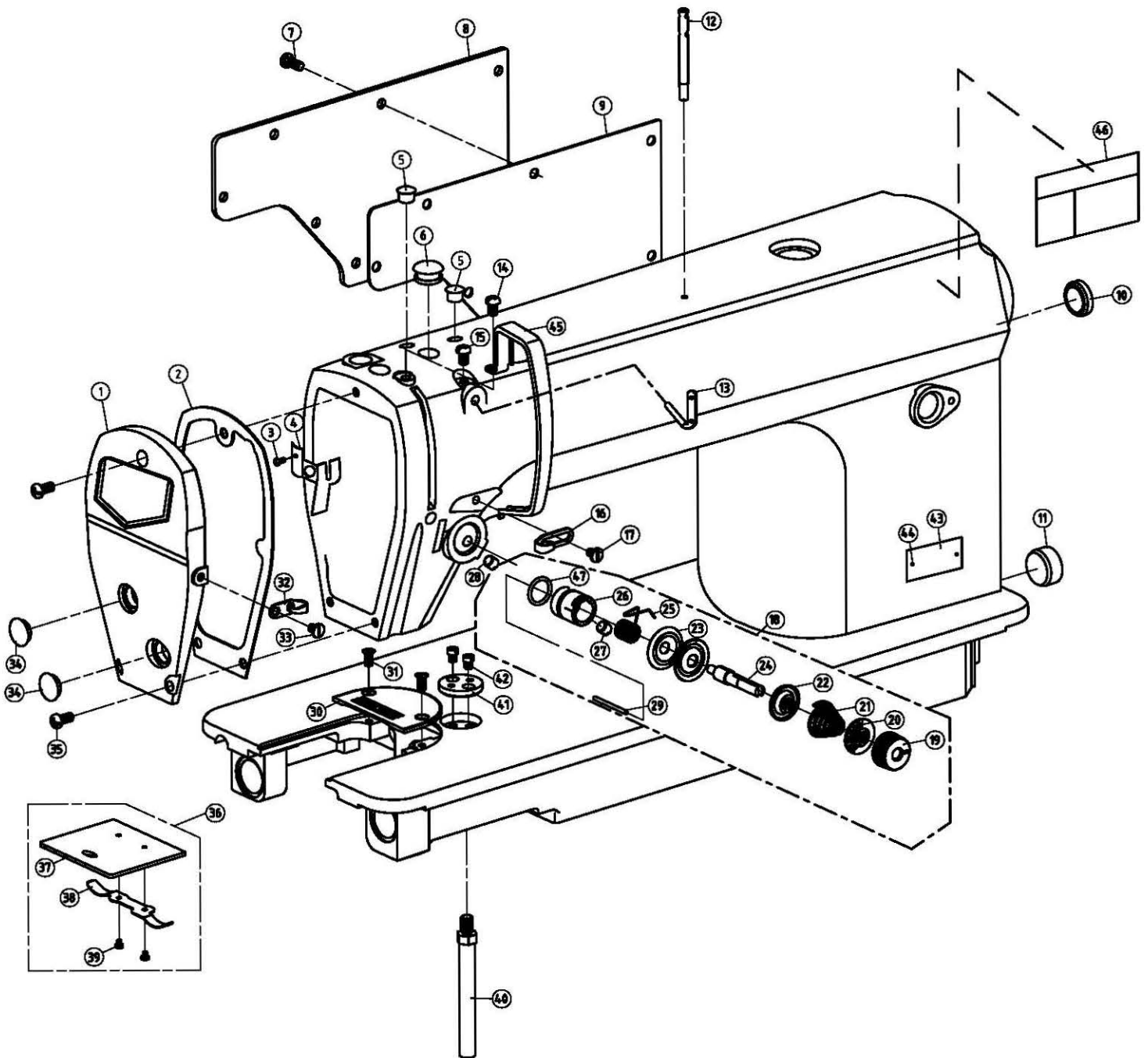

1、机壳分组件 Machine frame & miscellaneous cover components

序号 REF. No.	物料号 PART. No.	名称	DESCRIPTIONG	数量 QTY
1	20003526	面板	Face Plate	1
2	10008944	面板垫	Face Plate Packing	1
3	10005558	螺钉	Screw 1/8X44 L=9	1
4	10010339	面板防油板部件	ASM Oil Shield ASM.	1
5	10008943	螺孔塞	Rubber Plug	2
6	10008942	螺孔塞	Rubber Plug	1
7	10008972	螺钉3/16X28 L=9	Screw 3/16X28 L=9	8
8	20003525	后窗板	Side Plate	1
9	10008976	后窗板垫	Side Plate Gasket	1
10	10008975	孔塞	Rubber Plug	1
11	10008941	盲孔塞	Rubber Plug	1
13	10010640	三眼线勾	Three-hole Thread Eyelet	1
14	10008934	螺钉3/16X28 L=6	Screw 3/16X28 L=6	1
15	10008934	螺钉3/16X28 L=6	Screw 3/16X28 L=6	1
16	10008940	右线勾	Arm Thread Guide A	1
17	10008973	螺钉11/64X40 L=6	Screw 11/64X40 L=6	1
19	10004178	夹线螺母	Nut	1
20	10004199	夹线制动板	Tension Sisc Stopper	1
22	10004179	松线板	Tension Sisc Holder	1
23	10004180	夹线板	Tension Sisc	2
24	10004177	夹线螺钉	Screw	1
25	10004201	挑线簧	Take-up Spring	1
26	10010639	挑线簧调节座	Tension Post Socket	1
27	10004200	螺钉9/64X40 L=5.5	Screw 9/64X40 L=5	1
28	10006264	螺钉	Screw	1
29	10004184	松线钉	Thread Release Pin	1
31	10009005	螺钉11/64X40 L=8.5	Screw 11/64X40 L=8.5	2
32	10008937	左线勾	Arm Thread Guide B	1
33	10008973	螺钉11/64X40 L=6	Screw 11/64X40 L=6	1
34	10008977	螺孔塞	Rubber Plug	2
35	10008972	螺钉3/16X28 L=9	Screw 3/16X28 L=9	3
36	10013706	推板部件	Slide Plate ASM	1
37	10003960	推板	Slide Plate	1
38	10003963	推板簧	Spring Of Slide PLATE	1
39	10010080	螺钉3/32X56 L=1.9	Screw 3/32X56 L=1.9	2
40	10002577	底板支柱	Bed Screw Stud	4
41	10004373	限位挡片	Ruler Stop Seat	1
42	10004374	螺钉	Screw	2
44	10002840	型号牌铆钉	Pole	2
46	10008936	安全指示牌	Safety Label	1
47	10004183	O型圈	Rubber Ring	1

1、机壳分组件 Machine frame & miscellaneous cover components

序号 REF. No.	物料号 PART. No.	名称	DESCRIPTIONG	数量 QTY
薄、中厚料 For Light medium-heavy materials				
12	10004371	过线柱	Needle Thread Guide Pin	1
18	10010644	夹线器组件	Thread Tension asm.	1
21	10004176	夹线簧	Tension Spring	1
30	10012131	针板	Needle Plate	1
43	10005590	型号牌	Model Plate	1
45	10006418	挑线杆防护罩	Thread Take-up Lever Cover	1
厚料 For heavy materials				
12	10005639	过线柱	Needle Thread Guide Pin	1
18	10005942	夹线器组件	Thread Tension asm.	1
21	10005941	夹线簧	Tension Spring	1
30	10005917	针板	Needle Plate	1
43	10006506	型号牌	Model Plate	1
45	10006676	挑线杆防护罩	Thread Take-up Lever Cover	1
大旋梭厚料 For heavy weght materials (big roating hook)				
12	10005639	过线柱	Needle Thread Guide Pin	1
18	10005942	夹线器组件	Thread Tension asm.	1
21	10005941	夹线簧	Tension Spring	1
30	10005917	针板	Needle Plate	1
43	10004307	型号牌	Model Plate	1
45	10006676	挑线杆防护罩	Thread Take-up Lever Cover	1

2、主轴及挑线杆分组件 Main shaft & thread take-up lever components

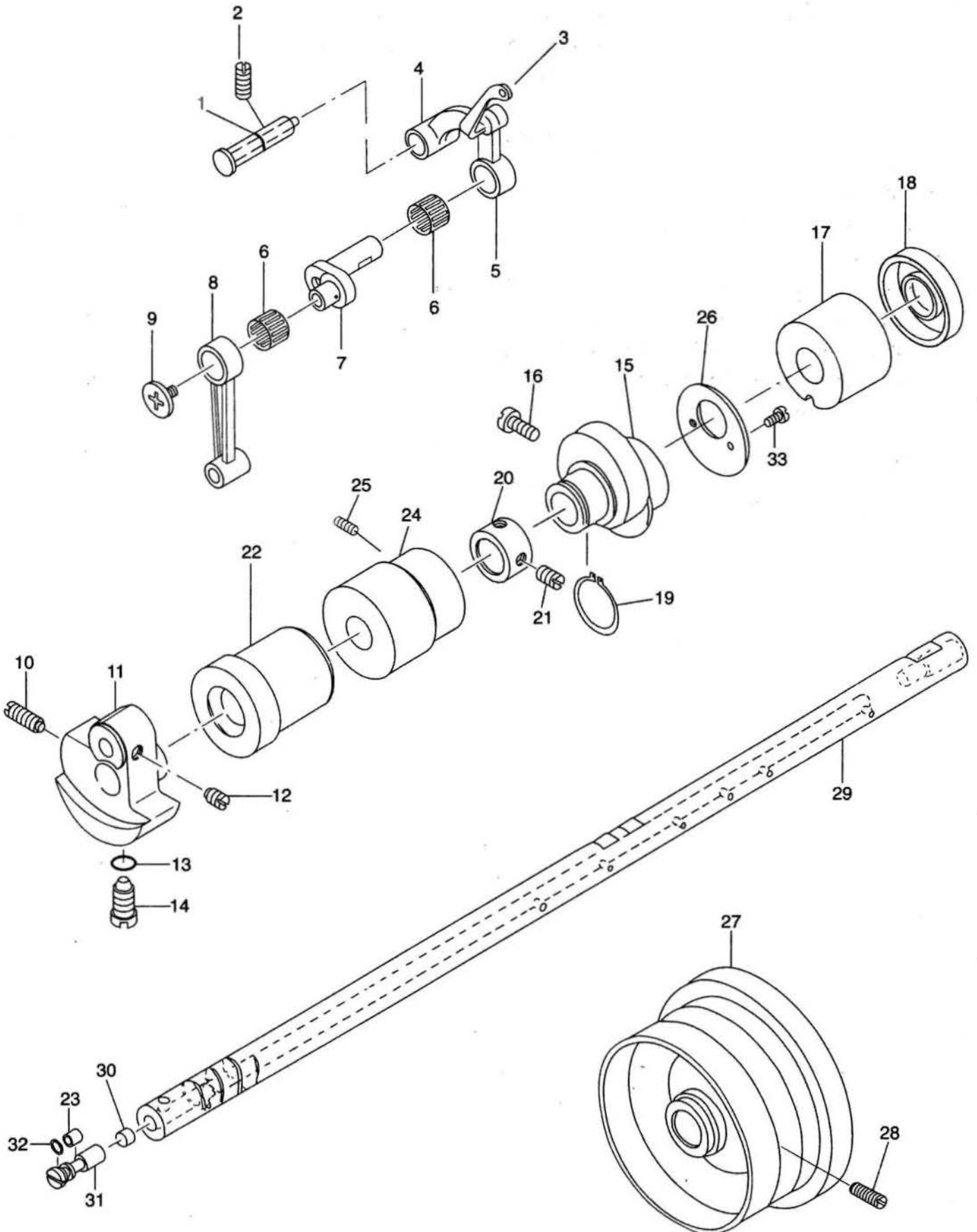

2、主轴及挑线杆分组件Main shaft & thread take-up lever components

序号 REF. No.	物料号 PART. No.	名称	DESCRIPTIONG	数量 QTY
1	20000648	挑线连杆销部件	Thread Take-up Crank Shaft	1
2	10010083	螺钉15/64X28 L=10.5	Screw 15/64X28 L=10.5	1
3	10010539	挑线杆防护油圈	Oil Resistant Cover	1
6	10014106	挑线杆滚针轴承	Needle Bearing	2
8	10010592	针杆连杆	Needle Bar Crank Rod	1
9	10010537	螺钉9/64X40 L=4.8	Screw 9/64X40 L=4.8	1
10	10010082	螺钉9/32X28 L=16	Screw 9/32X28 L=16	1
12	10005020	定位螺钉1/4X40 L=6	Screw 1/4X40 L=6	2
13	10010534	定位螺钉O型圈	Rubber Ring	1
14	10010545	螺钉9/32X28 L=6	Screw 9/32X28 L=6	1
16	10010092	螺钉1/4X40 L=11	Screw 1/4X40 L=11	2
17	10003927	上轴后轴套	Main Shaft Rear Bushing	1
18	10010507	上轴油封	Oil Seal	1
19	10010089	拾牙连杆轴用挡圈	Snap Ring	1
20	10010542	上轴挡圈	Thrust Collar	1
21	10005020	螺钉1/4X40 L=6	Screw 1/4X40 L=6	2
22	10007233	上轴前轴套	Main Shaft Front Bushing	1
23	10010504	曲柄油量调节销	Oil Amount Adjusting Pin	1
24	10003959	上轴中轴套	Intermediate Bushing	1
25	10010593	螺钉	Screw	1
27	20003683	上轮	Hand Wheel	1
28	10010536	上轮螺钉	Screw	2
29	10010544	上轴	Main Shaft	1
30	10010541	曲柄油量限制毡	Roller Felt	1
31	10010540	曲柄油量调节销套	Sleeve Of Oil Amount Adjusting Pin	1
32	10010538	O型圈	O-ring	1
33	10010643	螺钉9/64X40 L=6	Screw 9/64X40 L=6	2

2、主轴及挑线杆分组件 Main shaft & thread take-up lever components

序号 REF.No.	物料号 PART.No.	名称	DESCRIPTIONG	数量 QTY
薄、中厚料 For Light medium-heavy materials				
4	10010535	挑线连杆	Thread Take-up Bar	1
5	10004158	挑线连杆分组件	Thread Take-up Lever ASM.	1
7	10004144	挑线曲柄部件	Needle Bar Crank	1
11	10012203	针杆曲柄	Counter Weight	1
15	10010115	送料偏心轮	Feed Drive Eccentric	1
26	10010098	送料偏心轮盖板	Thrust	1
厚料 For heavy materials				
4	10005936	挑线连杆	Thread Take-up Bar	1
5	10005939	挑线连杆分组件	Thread Take-up Lever ASM.	1
7	10005937	挑线曲柄部件	Needle Bar Crank	1
11	10012858	针杆曲柄	Counter Weight	1
15	10005991	送料偏心轮	Feed Drive Eccentric	1
26	10005992	送料偏心轮盖板	Thrust	1
大旋梭厚料 For heavy weght materials (big roating hook)				
4	10005936	挑线连杆	Thread Take-up Bar	1
5	10005939	挑线连杆分组件	Thread Take-up Lever ASM.	1
7	10005937	挑线曲柄部件	Needle Bar Crank	1
11	10005938	针杆曲柄	Counter Weight	1
15	10005991	送料偏心轮	Feed Drive Eccentric	1
26	10005992	送料偏心轮盖板	Thrust	1

3、针杆、竖轴及旋梭驱动轴分组件 Needle bar, upright shaft & hook driving shaft components

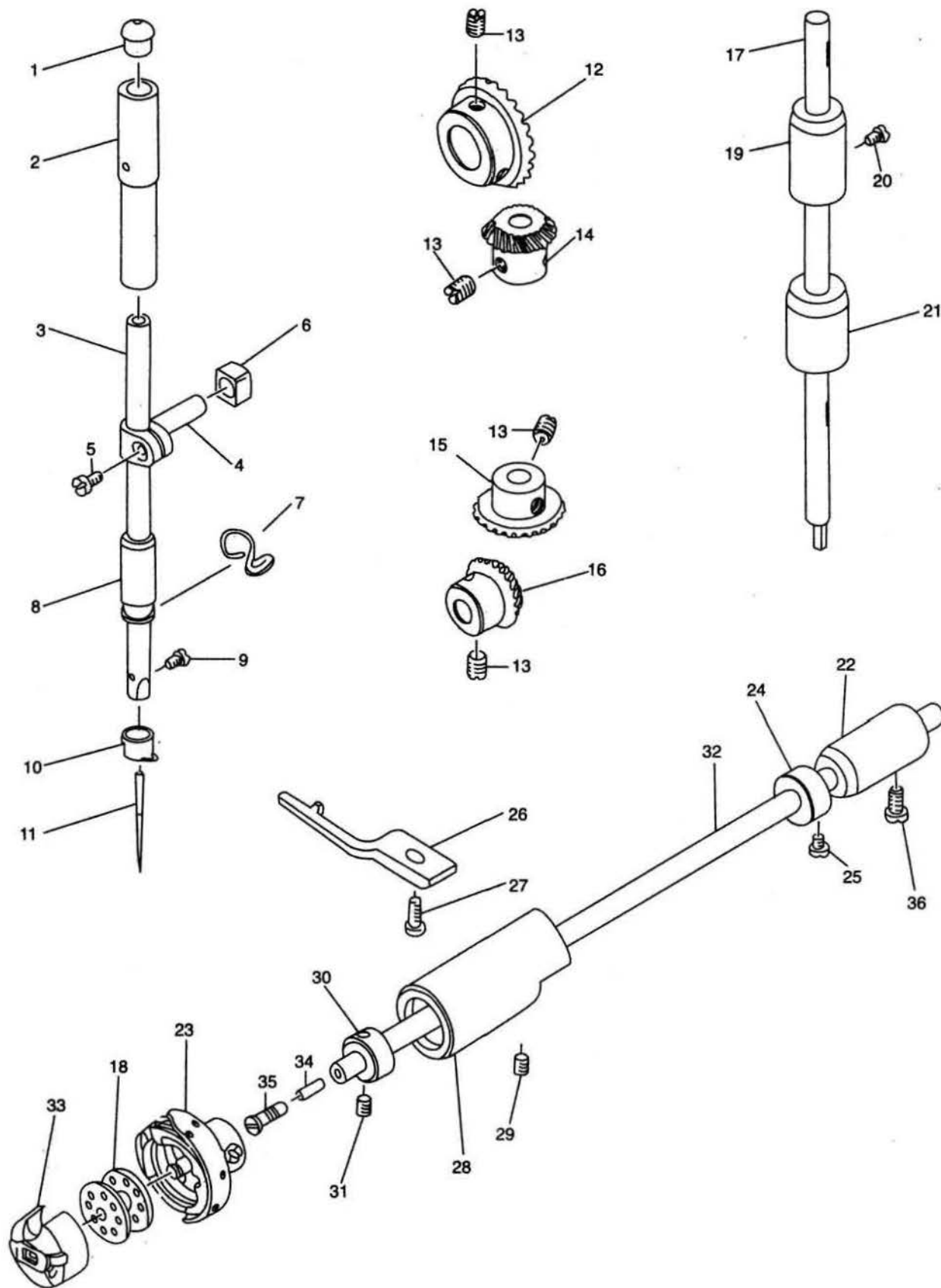

3、针杆竖轴及旋梭驱动轴分组件

Needle bar, upright shaft & hook driving shaft components

序号 REF. No.	物料号 PART. No.	名称	DESCRIPTIONG	数量 QTY
1	10010587	孔塞	Cap	1
2	10010589	针杆上轴套	Needle Bar Upper Bushing	1
4	10010590	针杆连接柱	Needle Bar Connecting-rod	1
5	10010643	螺钉9/64X40 L=6	Screw 9/64X40 L=6	1
6	10010586	针杆连接柱滑块	Slide Black	1
9	10010588	螺钉1/8X44 L=4.5	Screw 1/8X44 L=4.5	1
12	10010056	上轴伞齿轮 (大)	Gear Of Main Shaft(Big)	1
13	10010065	螺钉1/4X40 L=8	Screw 1/4X40 L=8	8
14	10010062	竖轴上伞齿轮 (小)	Gear Of Upright Shaft (small)	1
15	10010029	竖轴上伞齿轮 (大)	Gear Of Upright Shaft(Big)	1
16	10003937	下轴伞齿轮 (小)	Gear Of Hook Driving Shaft	1
19	10003961	竖轴上轴套	Upper Bushing	1
20	10008972	螺钉3/16X28 L=9	Screw 3/16X28 L=9	1
21	10003964	竖轴下轴套	Upright Shaft Lower Bushing	1
22	10003931	下轴后轴套	Rear Bushing	1
24	10010058	下轴挡圈	Thrust Collar	1
25	10010059	螺钉11/64X40 L=4.8	Screw 11/64X40 L=4.86	2
27	10010066	螺钉11/64X40 L=9.5	Screw 11/64X40 L=9.5	1
29	10010593	螺钉	Screw	1
30	10011065	下轴挡油圈	Thrust Collar	1
31	10010593	螺钉15/64X28 L=7.5	Screw 15/64X28 L=7.5	2

3、针杆竖轴及旋梭驱动轴分组件

Needle bar, upright shaft & hook driving shaft components

序号 REF. No.	物料号 PART. No.	名称	DESCRIPTIONG	数量 QTY
薄、中厚料 For Light medium-heavy materials				
3	10004182	针杆	Needle Bar	1
7	10010638	针杆下轴套线勾	Needle Bar Thread Guide	1
8	10014117	针杆下轴套	Needle Bar Lower Bushing	1
10	10010591	针杆线勾	Needle Bar Thread Guide	1
11	10004898	机针 (DBX1)	Needle DB X 1	1
17	10010057	竖轴	Upright Shaft	1
18	10010060	梭心	Bobbin	1
23	10023997	旋梭	Hook	1
26	10010067	旋梭定位钩	Positioning Finger	1
28	10004347	下轴前轴套	Front Bushing	1
32	10010061	下轴	Hook Driving Shaft	1
33	10003780	梭壳	Bobbin Case	1
厚料 For heavy materials				
3	10014469	针杆	Needle Bar	1
7	10005943	针杆下轴套线勾	Needle Bar Thread Guide	1
8	10005916	针杆下轴套	Needle Bar Lower Bushing	1
10	10005945	针杆线勾	Needle Bar Thread Guide	1
11	10003634	机针 (DBX1)	Needle DB X 1	1
17	10010057	竖轴	Upright Shaft	1
18	10010060	梭心	Bobbin	1
23	10007157	旋梭	Hook	1
26	10010067	旋梭定位钩	Positioning Finger	1
28	10004347	下轴前轴套	Front Bushing	1
32	10010061	下轴	Hook Driving Shaft	1
33	10007010	梭子	Bobbin Case	1
大旋梭厚料 For heavy weght materials (big roating hook)				
3	10005944	针杆	Needle Bar	1
7	10005943	针杆下轴套线勾	Needle Bar Thread Guide	1
8	10005916	针杆下轴套	Needle Bar Lower Bushing	1
10	10005945	针杆线勾	Needle Bar Thread Guide	1
11	10003634	机针 (DBX1)	Needle DB X 1	1
17	10005986	竖轴	Upright Shaft	1
18	10007138	梭心	Bobbin	1
23	10007008	旋梭	Hook	1
26	10005984	旋梭定位钩	Positioning Finger	1
28	10023394	下轴前轴套	Front Bushing	1
32	10005985	下轴	Hook Driving Shaft	1
33	10007390	梭子	Bobbin Case	1

4、压脚分组件 Presser foot components

序号 REF. No.	物料号 PART. No.	名称	DESCRIPTIONG	数量 QTY
1	10003922	压脚扳手	Hand Lifter	1
2	10010016	压脚扳手螺钉	Screw	1
3	10010027	O型圈	Rubber Ring	1
4	10010023	压脚扳手凸轮部件	Hand Lifter Cam	1
5	10008945	抬压脚前杠杆部件	Hand Lifter Link	1
6	10010649	拉杆开口挡圈	Snap Ring	1
7	10010653	前杠杆螺纹销	Link Shaft	2
9	10010026	开口挡圈	Snap Ring	3
10	10010648	压脚升降板	Lifting Lever	1
11	10010026	开口挡圈	Lifting Lever Ring	1
12	10010651	螺钉	Hinge Screw	1
13	10010652	螺钉	Hinge Screw	1
14	10010017	抬压脚后杠杆	Lifting Level Link	1
15	10010020	抬压脚顶杆	Connecting Rod Vertical	1
16	10010025	抬压脚拉杆	Lifting Level Connecting Rod	1
17	10010026	开口挡圈	Snap Ring	2
18	10010647	松线顶板复位簧	Tension Release Return Spring	1
19	10010642	松线辅钉弹簧	Tension Release Pin Spring	1
20	10010641	松线辅钉	Tension Release Supporting Pin	1
21	10010019	松线顶板	Tension Release Plate	1
22	10010022	螺纹销	Tension Release Shaft	1
23	10004205	调压螺钉	Presser Spring Regulation	1
24	10003917	调压螺母	Nut	1
25	10004439	调压导杆	Presser Guide Bar	1
27	10010024	压杆导架	Presser Bar Guide Bracket	1
28	10010646	压杆	Presser Bar	1
29	10010021	缓线调节钩	Presser Bar Thread Guide	1
30	10003921	螺钉1/4X40 L=8	Screw 1/4X40 L=8	1
31	10010018	螺钉9/64X40 L=8.5	Screw 9/64X40 L=8.5	2
33	10010650	螺钉9/64X40 L=10.5	Screw 9/64X40 L=10.5	1
薄、中厚料 For Light medium-heavy materials				
8	10010645	活压脚部件	Presser Foot ASM	1
26	10010647	调压簧	Presser Spring	1
32	10014118	压杆轴套	Presser Bar Lower Bushing	1
厚料 For heavy materials				
8	10005982	活压脚部件	Presser Foot ASM	1
26	10006068	调压簧	Presser Spring	1
32	10005915	压杆轴套	Presser Bar Lower Bushing	1
大旋梭厚料 For heavy weght materials (big roating hook)				
8	10005982	活压脚部件	Presser Foot ASM	1
26	10004473	调压簧	Presser Spring	1
32	10005915	压杆轴套	Presser Bar Lower Bushing	1

5. 送料分组件 Feed mechanism components

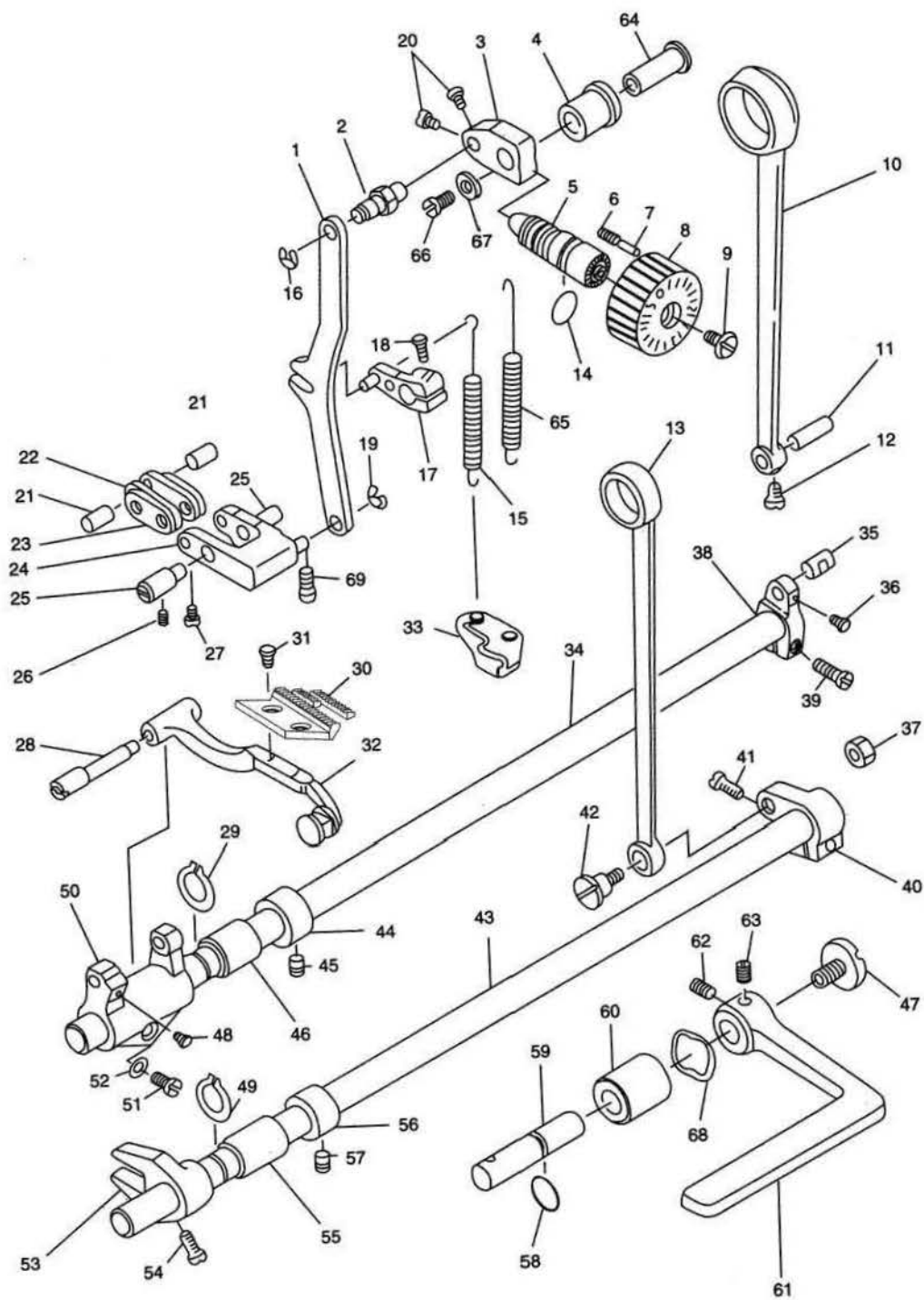

5、送料分组件 Feed mechanism components

序号 REF. No.	物料号 PART. No.	名称	DESCRIPTIONG	数量 QTY
4	10014120	送料调节器轴套	Feed Regulator Bushing	1
5	10010286	送料调节螺柱	Screw	1
6	10013869	送料距锁合簧	Spring	1
7	10013870	送料距锁合销	Pin	1
9	10010281	送料距旋钮螺钉	Screw	1
11	10010069	送料连杆销	Pin	1
12	10010071	螺钉9/64X40 L=6	Screw 9/64X40 L=6	1
13	10010084	拾牙连杆	Connecing Rod	1
14	10010240	送料调节螺柱O形圈	Rubber Ring	1
16	10010649	倒送料连杆挡圈	Snap Ring	1
19	10010649	倒送料连杆挡圈	Snap Ring	1
20	10010643	螺钉9/64X40 L=6	Screw 9/64X40 L=6	2
21	10010069	短摆动板连接销	Pin	2
22	10010068	送料长摆动板	Link (Long)	2
23	10010075	送料短摆动板	Link (short)	2
25	10010102	送料摆动板座右销	Adusting Link Shaft	2
26	10010506	螺钉15/64X28 L=7	Screw 15/64X28 L=7	1
27	10010071	螺钉9/64X40 L=7	Screw 9/64X40 L=7	1
28	10004440	牙架销	Feed Bar Shaft	1
29	10010090	送料轴轴用挡圈	Retaining Ring	1
31	10010099	螺钉1/8X44 L=6	Screw 1/8X44 L=6	2
34	10010073	送料轴	Feed Spring Hook	1
35	10010096	送料曲柄销	Pin	1
36	10010643	螺钉9/64X40 L=6	Screw 9/64X40 L=6	1
37	10004475	螺母9/32X28	9/32X28 Nut	1
39	10010095	螺钉3/16X28 L=15.5	Screw 3/16X28 L=15.5	1
40	10010086	拾牙后曲柄	Lifting Rocker	1
41	10010095	螺钉3/16X28 L=15.5	Screw 3/16X28 L=15.5	1
42	10010091	轴位螺钉	Screw	1
43	10010097	拾牙轴	Feed Driving Shaft	1
44	10010090	送料轴挡圈	Thrust Collar	1
45	10005020	螺钉1/4X40 L=6	Screw 1/4X40 L=6	2
46	10014116	送料轴前轴套	Feed Rocker Shaft Bushing	1
48	10010074	螺钉11/64X40 L=7	Screw 11/64X40 L=7	1
49	10010090	拾牙轴轴用挡圈	Retaining Ring	1
50	10004474	牙架座	Feed Bar Driving Crank	1
51	10004993	螺钉3/16X28 L=14	Screw 3/16X28 L=14	1
52	10010085	牙架座螺钉垫圈	Washer	1
53	10010100	拾牙叉形曲柄	Lifting Fork	1
54	10010093	螺钉11/64X40L=10.5	Screw 11/64X40L=10.5	1
55	10014116	拾牙轴前轴套	Feed Rocker Shaft Bushing	1

5、送料分组件 Feed mechanism components

序号 REF. No.	物料号 PART. No.	名称	DESCRIPTIONG	数量 QTY
56	10010090	拾牙轴挡圈	Thrust Collar	1
57	10005020	螺钉1/4X40 L=6	Screw 1/4X40 L=6	2
58	10010243	倒送料轴O形圈	Rubber Ring	1
60	10014119	倒送料轴轴套	Bushing	1
61	20003731	倒送料扳手	Reverse FEED Controllever	1
62	10003921	螺钉1/4X40 L=8	Screw 1/4X40 L=8	1
63	10003921	螺钉1/4X40 L=8	Screw 1/4X40 L=8	1
69	10010506	螺钉15/64X28 L=7	Screw 15/64X28 L=7	1
薄、中厚料 For Light medium-heavy materials				
1	10010283	倒送料连杆	Feed Adjust Rod	1
2	10010288	倒送料连杆销	Feed Regulator Pin	1
3	10010242	送料调节器	Feed Regulator	1
8	10004042	送料距旋钮	Feed Dial	1
10	10010072	送料连杆	Conneeting Rod	1
15	10010237	倒送料拉簧	Spring	1
17	20001767	倒送料曲柄部件	Reverse Feed Arm ASM	1
18	10010236	倒送料曲柄螺钉	Screw	1
24	10003966	倒送料摆动板座部件	Feed Adjust ASM	1
30	10011066	送料牙	Feed Dog	1
32	20001665	牙架部件	Feed Bar ASM	1
33	10010235	拉簧固定板	Feed Spring Hook	1
38	10010076	送料曲柄	Feed Rocker	1
47	10010238	螺钉	Screw	1
59	10010241	倒送料轴	Reverse Feed Shaft	1
65	10010284	摆动板座复位簧	Reverse Feed Spring	1
厚料 For heavy materials				
1	10006018	倒送料连杆	Feed Adjust Rod	1
2	10006007	倒送料连杆销	Feed Regulator Pin	1
3	10006011	送料调节器	Feed Regulator	1
8	10006012	送料距旋钮	Feed Dial	1
10	10006004	送料连杆	Conneeting Rod	1
15	10004430	倒送料拉簧	Spring	1
17	20005688	倒送料曲柄部件	Reverse Feed Arm ASM	1
18	10010095	倒送料曲柄螺钉	Screw	1
24	10005989	倒送料摆动板座部件	Feed Adjust ASM	1
30	10006005	送料牙	Feed Dog	1
32	20001665	牙架部件	Feed Bar ASM	1
33	10006015	拉簧固定板	Feed Spring Hook	1
38	10005990	送料曲柄	Feed Rocker	1
47	10006912	螺钉	Screw	1
59	10010241	倒送料轴	Reverse Feed Shaft	1
64	10006014	送料调节器轴	Feed adjusting shaft	1

5、送料分组件 Feed mechanism components

序号 REF. No.	物料号 PART. No.	名称	DESCRIPTIONG	数量 QTY
65	10006010	摆动板座复位簧	Reverse Feed Spring	1
66	10006008	送料调节器螺钉	Washer	1
67	10006013	送料调节轴垫圈	Washer	1
68	10006006	倒送料轴端垫圈	Washer	1
大旋梭厚料 For heavy weght materials (big roating hook)				
1	10006018	倒送料连杆	Feed Adjust Rod	1
2	10006007	倒送料连杆销	Feed Regulator Pin	1
3	10006011	送料调节器	Feed Regulator	1
8	10006012	送料距旋钮	Feed Dial	1
10	10006004	送料连杆	Conneeting Rod	1
15	10004430	倒送料拉簧	Spring	1
17	20005688	倒送料曲柄部件	Reverse Feed Arm ASM	1
18	10010095	倒送料曲柄螺钉	Screw	1
24	10005989	倒送料摆动板座部件	Feed Adjust ASM	1
30	10006005	送料牙	Feed Dog	1
32	20002335	牙架部件	Feed Bar ASM	1
33	10006015	拉簧固定板	Feed Spring Hook	1
38	10005990	送料曲柄	Feed Rocker	1
47	10006912	螺钉	Screw	1
59	10010241	倒送料轴	Reverse Feed Shaft	1
64	10006014	送料调节器轴	Feed adjusting shaft	1
65	10006010	摆动板座复位簧	Reverse Feed Spring	1
66	10006008	送料调节器螺钉	Washer	1
67	10006013	送料调节轴垫圈	Washer	1
68	10006006	倒送料轴端垫圈	Washer	1

6. 润滑分组件 Oil lubrication components

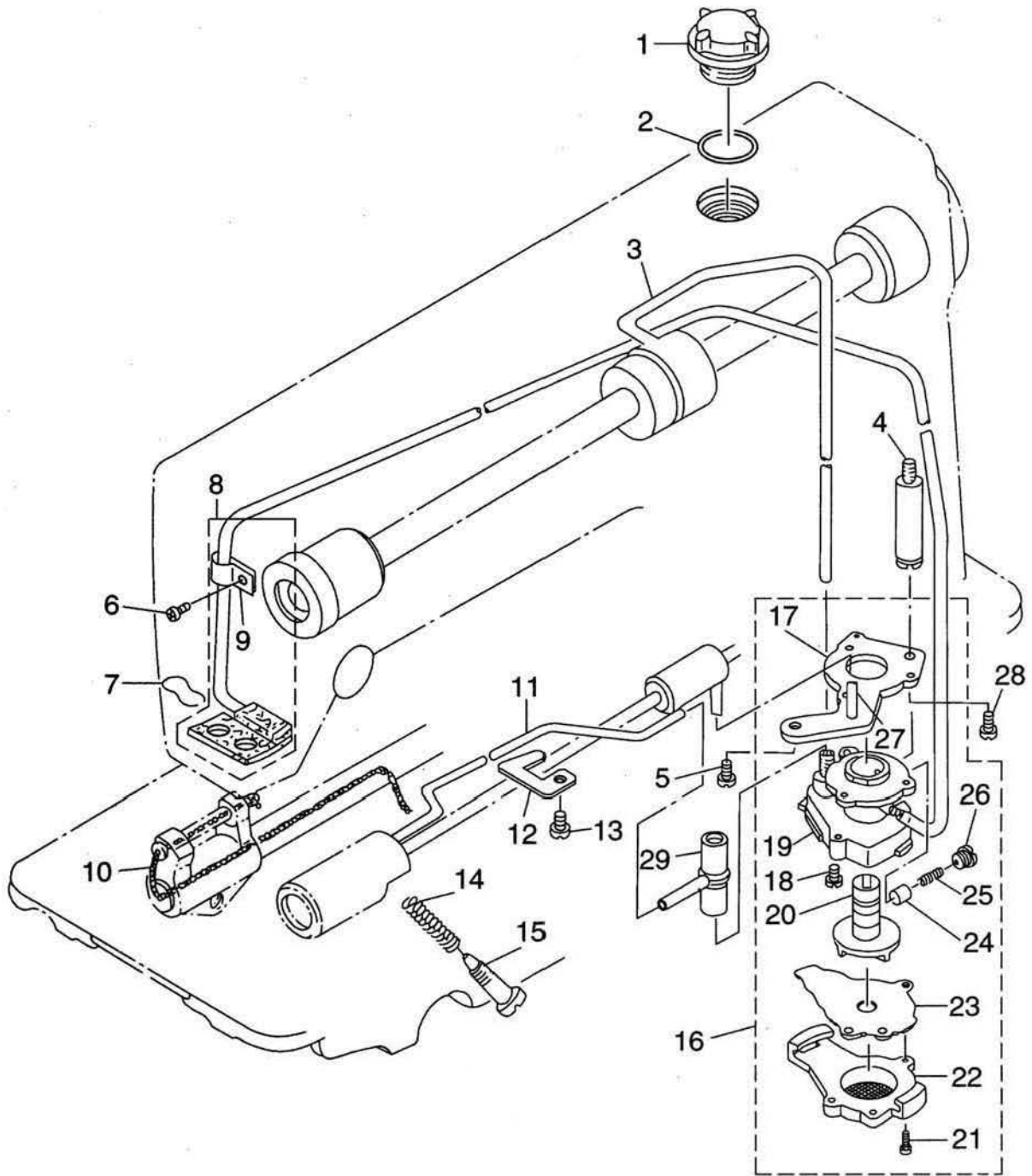

6、润滑分组件 Oil lubrication components

序号 REF. No.	物料号 PART. No.	名称	DESCRIPTIONG	数量 QTY
1	10008938	油窗	Oil Singt Window	1
2	10008939	油窗O形圈	Rubber Ring	1
3	10010343	上轴供油管	Main Shaft Oil Tube	1
4	10010293	油泵连接螺柱	Oil Pump Support	1
5	10010292	螺钉15/64X28 L=9	Screw 15/64X28 L=9	1
6	10008934	螺钉3/16X28 L=6	Screw 3/16X28 L=6	1
7	10010294	回油毡夹	Oil Felt Presser	1
8	20000778	回油管组件	Oil REturn Tube ASM	1
9	10004476	回油管夹	Holder	1
10	10008067	送料轴油线	Oil Wick	1
11	10010345	旋梭供油管	Oil Tube	1
12	10010295	旋梭供油管压板	Tube Holder Lower	1
13	10010292	螺钉15/64X28 L=9	Screw 15/64X28 L=9	1
14	10010341	旋梭油量调节簧	Spring	1
15	10010344	螺钉	Oil Adjusting Screw	1
16	10008817	油泵部件	Oil Pump ASM	1
17	10004046	油泵安装板	Oil Pump Installing Base	1
18	10004062	螺钉M3X8	Screw M3X8	3
19	10002476	油泵体	Oil Pump	1
20	10004063	油泵叶轮	Oil Pump Impeller	1
21	10004064	螺钉	Screw	3
22	10004044	油泵盖	Oil Pump Cover	1
23	10004066	油泵叶轮托板	Oil Pump Impeller Cover	1
24	10004056	回油柱塞	Plunger	1
25	10004059	柱塞簧	Plunger Spring	1
26	10004043	柱塞螺钉	Plunger Screw	1
27	10004060	下轴供油管	Hook Driving Shaft Oil Tube	1
28	10010066	螺钉11/64X40 L=9.5	Screw 11/64X40 L=9.5	1
29	10010340	供油管接头	Oil Tube Joint	1

7、油盘分组件 Oil reservoir components

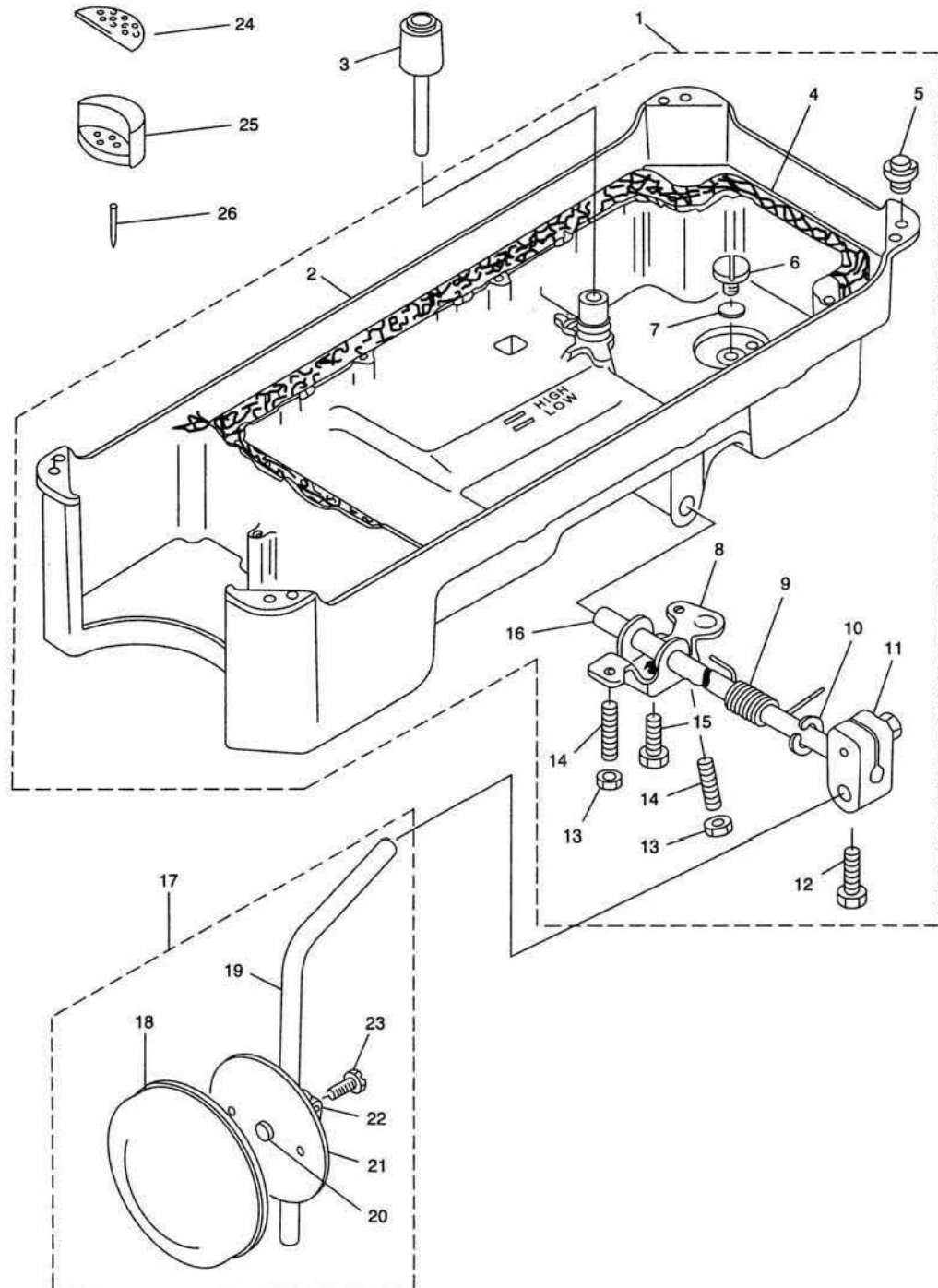

7、油盘分组件 Oil reservoir components

序号 REF. No.	物料号 PART. No.	名称	DESCRIPTIONG	数量 QTY
1	20005394	油盘部件	Oil Reservoir ASM	1
2	10008313	油盘	Oil Reservoir	1
3	10004222	抬压脚顶销	Top Pin Of Lifting Presser Foot	1
4	10009989	油盘垫	Oil Reservoir Gasket	1
5	10009993	机头座垫	Head Gasket	4
6	10009991	排油孔螺钉	Screw	1
7	10009988	O形圈	Rubber Ring	1
8	10009987	抬压脚双向曲柄	Two-way Crank Of Lifting Presser Foot	1
9	10003893	双向曲柄扭簧	Twisting Spring Of Two Way Crank	1
10	10002559	抬压脚轴开口挡圈	Snap Ring	1
11	10003896	抬压脚操纵杆节头	Bracket	1
12	10002613	螺栓	Screw	1
13	10003890	螺母15/64X28	Nut 15/64X28	2
14	10003895	螺钉15/64X28 L=30	Screw 15/64X28 L=30	2
15	10003898	螺钉	Screw	1
16	10003899	抬压脚轴	Knee Pressing Shaft	1
17	10009985	操纵杆部件	Knee Pressing Plate ASM	1
18	10004223	操纵板软垫	Knee Pressing Plate Cover	1
19	10003901	操纵杆	Knee Pressing Plate Rod	1
20	10003900	操纵杆垫	Knee Pressing Plate Rubble	1
21	10003891	操纵板	Knee Pressing Plate	1
22	10003897	操纵杆节头	Knee Pressing Plate Holder	1
23	10003894	螺钉15/64X28 L=15	Screw 15/64X28 L=15	1
24	10009986	油盘座垫	Oil Reservoir Cushion	2
25	10009986	油盘支座	Oil Reservoir Seat	4
26	10003889	油盘座钉	Oil Reservoir Nail	4

8、皮带罩、绕线器与过线架分组件 Belt cover, bobbin winder & thread stand components

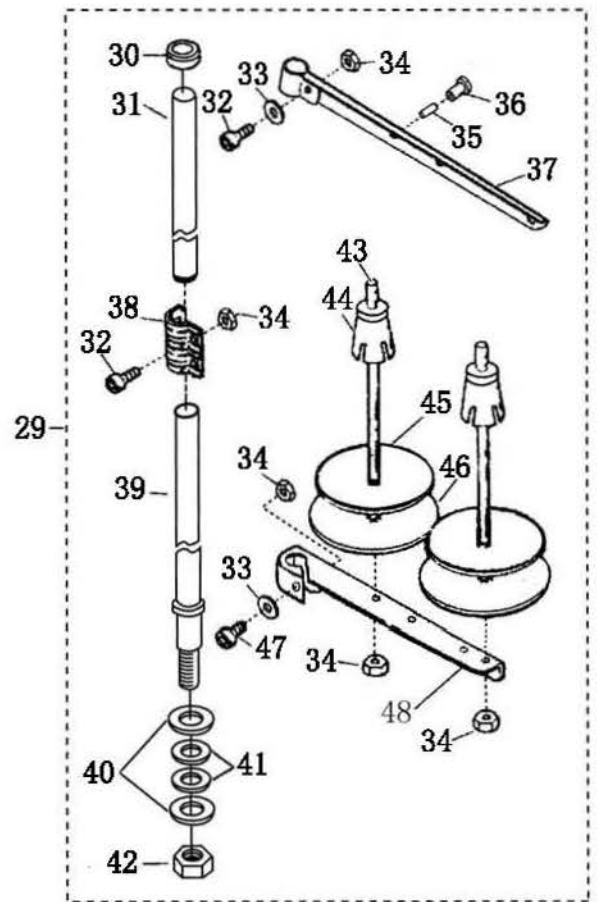
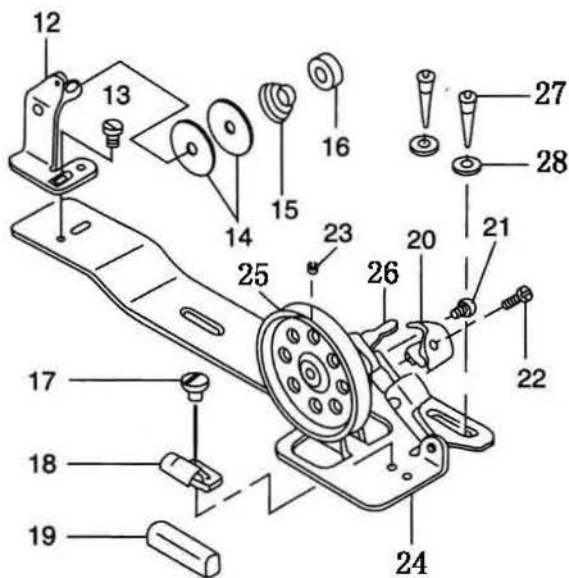
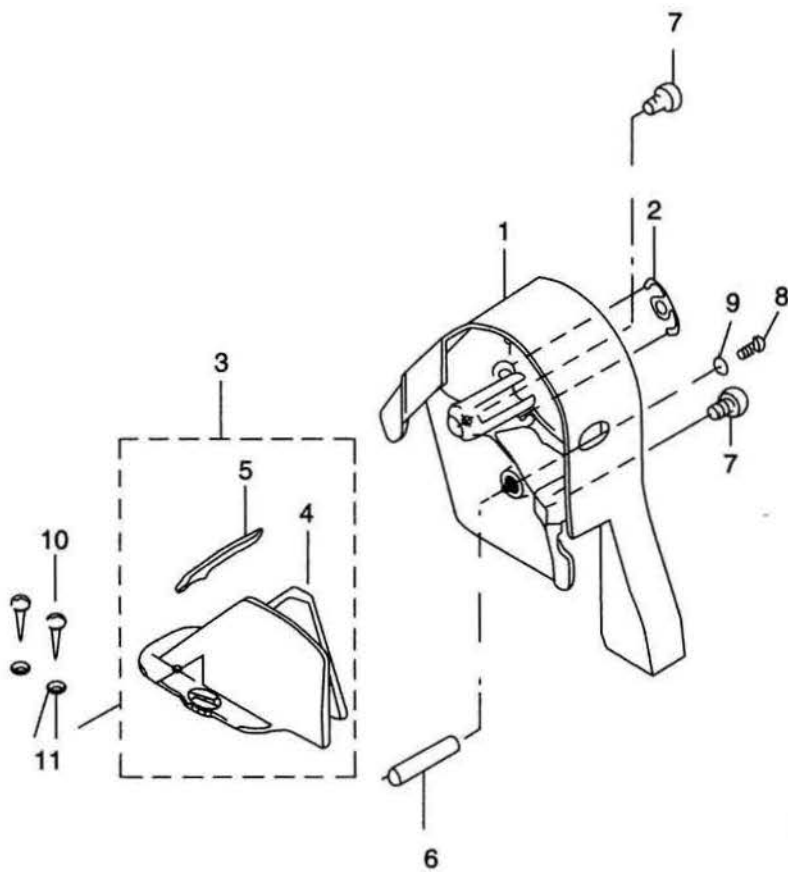

8、皮带罩、绕线器与过线架分组件

序号 REF. No.	物料号 PART. No.	名称	DESCRIPTIONG	数量 QTY
1	10004464	上轮前罩壳	Belt Cover	1
2	10004460	前罩壳安装架	Belt Cover Cap	1
3		上轮后罩壳组件	Rear Belt Cover ASM	1
4	10004465	上轮后罩壳	Rear Belt Cover	1
5	10004457	后罩壳盖部件	Rear Cover ASM	1
6	10011153	后罩壳支柱	Belt Cover Support	1
7	10010842	螺钉	Screw	2
8	10010993	支柱螺钉	Screw	1
9	10012318	螺钉垫圈	Washer	1
10	10008323	后罩壳安装木螺钉	Screw	2
11	10003083	木螺钉垫圈	Washer	2
12	10004300	过线架座部件	Thread Tension ASM	1
13	10004324	螺钉11/64X40 L=7.8	Screw 11/64X40 L=7.8	1
14	10004321	过线夹线板	Thread Tension Dick	2
15	10004314	过线夹线簧	Thread Tension Spring	1
16	10004315	过线夹线螺母	Tension Nut	1
17	10004325	螺钉11/64X40 L=5	Screw 11/64X40 L=5	1
18	10004312	制动垫夹	Presser Plate	1
19	10004320	绕线轮制动垫	Rubber Brake	1
20	10004319	满线跳板簧	Positioning Finger	1
21	10004301	螺钉1/8X44 L=12.5	Screw 1/8X44 L=12.5	1
22	10004316	满线跳板螺钉	Screw	1
23	10004329	绕线轮螺钉	Screw	1
24	10004326	绕线座部件	Bobbin Winder ASM	1
25	10004327	绕线轮	Bobbin Wheel	1
26	10004318	绕线轴	Bobbin Shaft	1
27	10008197	绕线器木螺钉	Screw	2
28	10003083	绕线品木螺钉垫圈	Washer	2
29	10007130	二线线架部件	Thread Stand Asm.	
30	10004282	线架上撑管套	Column Cap	1
31	10004293	线架上撑管	Column Pipe(Upper)	1
32	10003301	M5×14螺钉	Screw	2
33	10003022	垫圈	Washer	5
34	10002953	M5螺母	Nut	5
35	10004289	过线管	Thread Guide Pipe	1
36	10004285	过线管套	Thread Guide Bushing	1
37	10004298	上过线架	Thread Hanger(Upper)	1
38	10004286	撑管夹	Column Pipe Connector	1
39	10004291	线架下撑管	Column Pipe(Lower)	1
40	10004290	垫圈	Washer 16×30×1.5	2
41	10004295	垫圈	Washer 16.5×27.5×3	2

8、皮带罩、绕线器与过线架分组件

序号 REF. No.	物料号 PART. No.	名称	DESCRIPTIONG	数量 QTY
42	10002953	M5螺母	Nut	1
43	10004288	线轴	Spool	2
44	10004287	线盘塑料压块	Spool Cushion	2
45	10004281	线盘软垫	Soft Cushion Of Thread Plate	2
46	10004299	线盘	Thread Plate	2
47	10003312	M5×30螺钉	Screw	1
48	10004284	下过线架	Thread Hanger (Lower)	1

10. 附件 Accessories

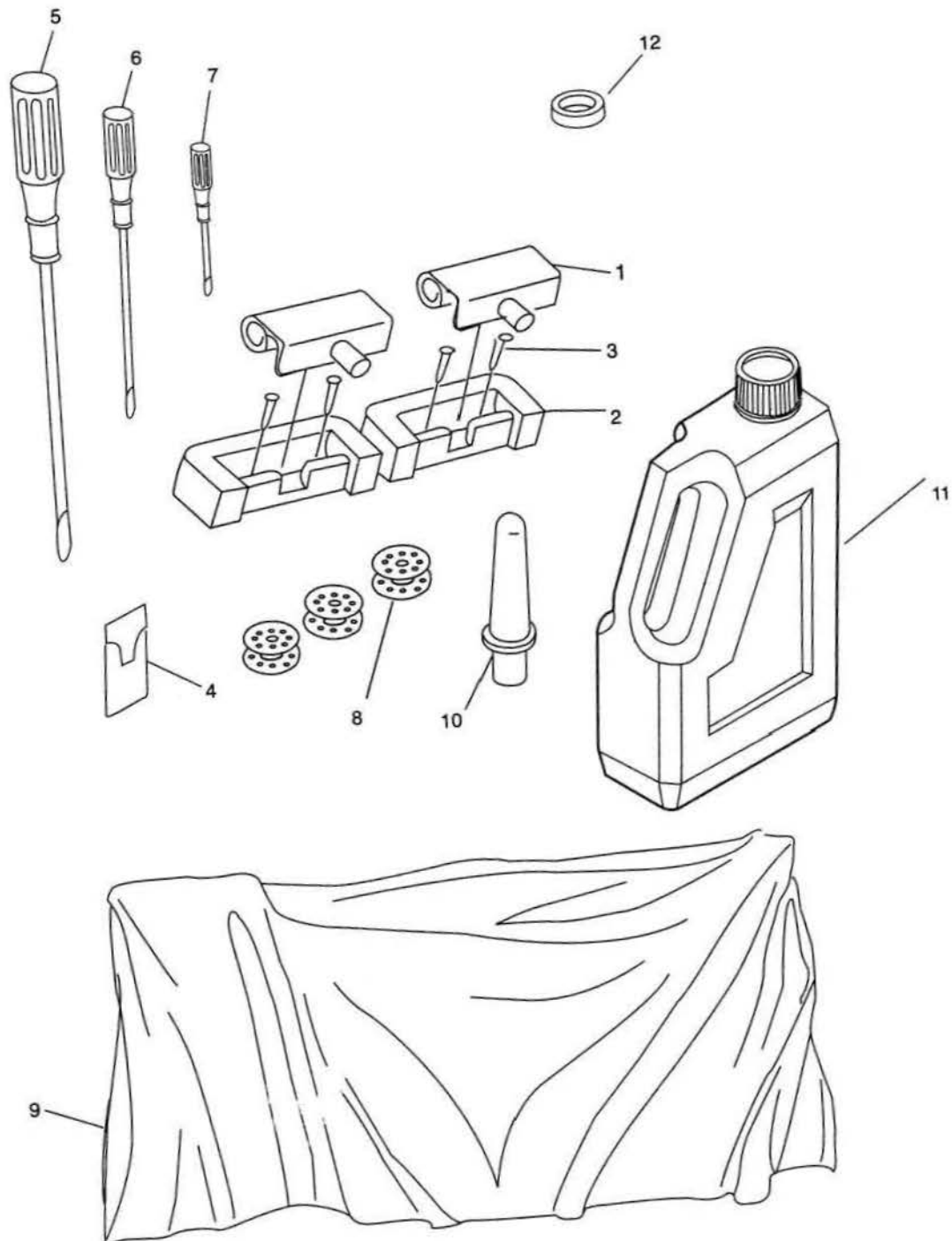

9、附件 Accessories

序号 REF. No.	物料号 PART. No.	名称	DESCRIPTIONG	数量 QTY
1	10004466	机头连接钩部件	Head Connecting Hook	2
2	10011041	机头连接钩座	Head Connecting Hook Socket	2
3	10003889	机头连接钩座钉	Head Connecting Hook Nail	4
5	10010994	螺丝刀 (大)	Screw Driver(L)	1
6	10010995	螺丝刀 (中)	Screw Driver(M)	1
7	10013185	螺丝刀 (小)	Screw Driver(S)	1
9	10004399	机头罩	Head Cover	1
10	10004514	机头支柱	Head Pole	1
11	10004455	油箱部件	Oil Bottle With Oil	1
12	10003892	油盘磁铁	Oil Reservoir Magnet	1
薄、中厚料 For Light medium-heavy materials				
4	10004898	机针 (DBX1)	Needle DB X 1	1包
8	10010060	梭心	Bobbin	3
厚料 For heavy materials				
4	10003634	机针 (DBX1)	Needle DB X 1	1包
8	10010060	梭心	Bobbin	3
大旋梭厚料 For heavy weght materials (big roating hook)				
4	10003634	机针 (DBX1)	Needle DB X 1	1包
8	10007138	梭心	Bobbin	3