

ZJ 8700

INSTRUCTION MANUAL

To get the most out of the many functions of this machine and operate it in safety, it is necessary to use this machine correctly.

Please read this Instruction Manual carefully before use. We hope you will enjoy the use of your machine for a long time.

Please remember to keep this manual in a safe place.

1. Observe the basic safety measures, including, but not limited to the following ones, whenever you use the machine.
2. Read all the instructions, including, but not limited to this Instruction Manual before you use the machine. In addition, keep this Instruction Manual so that you may read it at anytime when necessary.
3. Use the machine after it has been ascertained that it conforms with safety rules/standards valid in your country.
4. All safety devices must be in position when the machine is ready for work or in operation. The operation without the specified safety devices is not allowed.
5. This machine shall be operated by appropriately-trained operators.
6. For your personal protection, we recommend that you wear safety glasses.
7. For the following, turn off the power switch or disconnect the power plug of the machine from the receptacle.
 - 7-1 For threading needle(s) and replacing bobbin.
 - 7-2 For replacing part(s) of needle, presser foot, throat plate, feed dog, cloth guide etc.
 - 7-3 For repair work.
 - 7-4 When leaving the working place or when the working place is unattended.
8. If you should allow oil, grease, etc. used with the machine and devices to come in contact with your eyes or skin or swallow any of such liquid by mistake, immediately wash the contacted areas and consult a medical doctor.

9. Tampering with the live parts and devices, regardless of whether the machine is powered, is prohibited.
10. Repairing, remodeling and adjustment works must only be done by appropriately trained technicians or specially skilled personnel.
11. General maintenance and inspection works have to be done by appropriately trained personnel.
12. Repair and maintenance works of electrical components shall be conducted by qualified electric technicians or under the audit and guidance of specially skilled personnel. Whenever you find a failure of any of electrical components, immediately stop the machine.
13. Periodically clean the machine throughout the period of use.

14. Grounding the machine is always necessary for the normal operation of the machine. The machine has to be operated in an environment that is free from strong noise sources such as high-frequency welder.

15. An appropriate power plug has to be attached to the machine by electric technicians, Power plug has to be connected to a grounded receptacle.

16. The machine is only allowed to be used for the purpose intended. Other uses are not allowed.

17. Remodel or modify the machine in accordance with the safety rules/standards while taking all the effective safety measures. We assume no responsibility for damage caused by remodeling or modification of the machine.

18. Warning hints are marked with the two shown symbols.





Danger of injury to operator or service staff



Items requiring special attention

FOR SAFE OPERATION

	<ol style="list-style-type: none">1. To avoid electrical shock hazards, neither open the cover of the electrical box for the motor nor touch the components mounted inside the electrical box.
	<ol style="list-style-type: none">1. To avoid personal injury, never operate the machine with any of the belt cover, finger guard of safety devices removed.2. To prevent possible personal injuries caused by being caught in the machine, keep your fingers, head and clothes away from the handwheel, V belt and the motor while the machine is operation. In addition, place nothing around them.3. To avoid personal injury, never put your hand under the needle when you turn "ON" the power switch or operate the machine.4. To avoid personal injury, never put your fingers into the thread take-up cover while the machine is in operation.5. The hook rotates at a high speed while the machine is in operation. To prevent possible injury to hands, be sure to keep your hands away from the vicinity of the hook during operation. In addition, be sure to turn OFF the power to the machine when replacing the bobbin.6. To avoid possible personal injuries, be careful not to allow your fingers in the machine when tilting/raising the machine head.7. To avoid possible accidents because of abrupt start of the machine, turn OFF the power to the machine when tilting the machine head or removing the belt cover and the V belt.8. If your machine is equipped with a servo-motor, the motor does not produce noise while the machine is at rest. To avoid possible accidents due to abrupt start of the machine, be sure to turn OFF the power to the machine.9. To avoid electrical shock hazards, never operate the sewing machine with the ground wire for the power supply removed.10. To prevent possible accidents because of electric shock or damaged electrical component(s), turn OFF the power switch in prior to the connection/disconnection of the power plug.

CONTENTS

BEFORE OPERATION.....	15
1. INSTALLATION.....	15
2. LUBRICATION.....	16
3. ADJUSTING THE AMOUNT OF OIL (OIL SPRASHES) IN THE HOOK.....	16
4. ATTACHING THE NEEDLE.....	18
5. SETTING THE BOBBIN INTO THE BOBBIN CASE.....	18
6. THREADING THE MACHINE HEAD.....	19
7. ADJUSTING THE STITCH LENGTH.....	19
8. THREAD THENSION.....	20
9. THREAD TAKE-UP SPRING.....	20
10. HAND LIFTER.....	21
11. PRESSER FOOT PRESSURE.....	21
12. ADJUSTING THE FEED TIMING.....	21
13. HEIGHT OF THE FEED DOG.....	22
14. NEEDLE-TO-HOOK RELATIONSHIP.....	22
15. ADJUSTING THE HEIGHT OF THE PRESSER FOOT.....	23
16. ADJUSTING THE THREAD TAKE-UP STROKE.....	23
17. INSTALLING THE BELT COVER AND THE BOBBIN WINDER.....	23
18. ADJUSTING THE HEIGHT OF THE KNEE LIFTER.....	24
19. SPECIFICATIONS.....	25

Attention required before operation

Attention:

To avoid machine damaging or some accident, please do remember:

- 1.before using the machine for the first time,please clean it thoroughly,get rid of all the dust and make sufficient lubrication.
- 2.make sure that the voltage is right,and that plug and power source are correctly connected.
- 3.if the voltage in your country is different from the voltage of this machine,please do not use it.
- 4..make sure the running direction of the motor wheel is right.
- 5.during the first month when using this machine,you should run it in the normal speed or lower speed.

Fixing of the machine



Fig.1

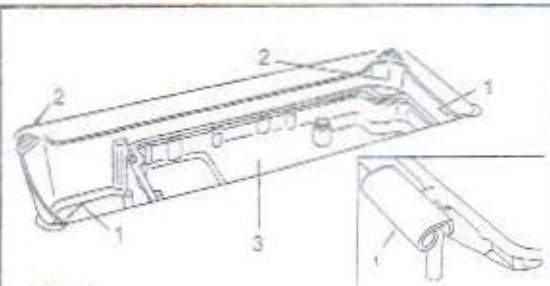

Fig.3

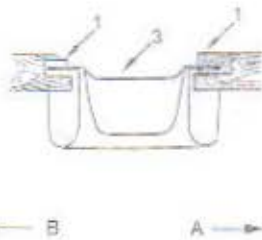

Fig.2

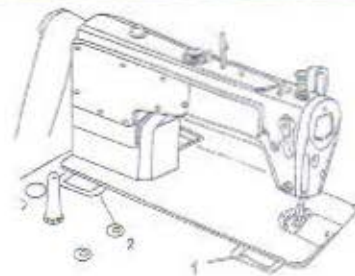

Fig.4

1.fixing oil tray

- 1) oil tray should be put at the four corners of the slot in table plate.
- 2) Fix two arm cushion "1" to the "A" side of oil tray "3" (facing the operator). Fix the two stand bases "2" to the "B" side of oil tray "3" (hinge side), then fix the oil tray "3" (picture 1, picture 2)
- 3) Plug the hinge "1" into hole of bed plate, put the machine head on the table plate, hinge at the sink place and then fix the machine head on cushions of the four oil tray corners (picture 3, picture 4).

attention: in the packing box, the rubber cushions fixed at the four corner of oil tray is not for any other usage, just for packaging.

2. LUBRICATION (Fig,5,6)



WARNING:

Turn OFF the power before starting the work so as to prevent accidents caused by abrupt start to the sewing machine.

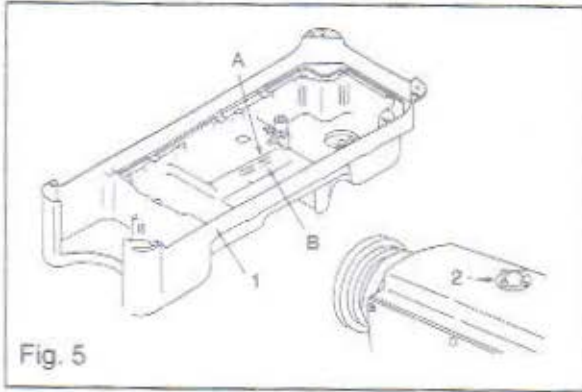

Fig. 5

1. Information on lubrication

- 1) Fill oil pan ① with sewing-machine oil(No.10 white oil) up to HIGH mark A.
 - 2) When the oil level lowers below LOW mark B, refill the oil pan with the specified oil.
 - 3) When you operate the machine after lubrication, you will see splashing oil through oil singht window ② if the lubrication is adequate.
 - 4) Note that the amount of the splashing oil is unrelated to the amount of the lubricating oil.
- (Precaution) When you first operate your machine after setup or after an extended period of disuse, run your machine at 2,000 s.p.m. To 2,500 s.p.m for about 10 minuter for the purpose of break-in.



WARNING:

Turn OFF the power before starting the work so as to prevent accidents caused by abrupt start to the sewing machine.

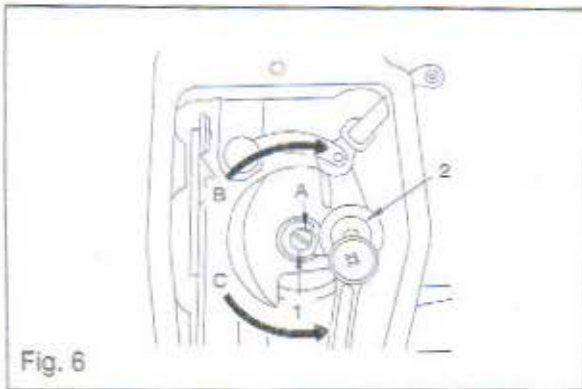

Fig. 6

2. Adjusting the amount of oil supplied to the face plate parts.

- 1) Adjust the amount of oil supplied to the thread take-up and needle bar crank ② by turning adjust pin ① .
- 2) The minimum amount of oil is reached when marker dot A is brought close to needle bar crank ② by turning the adjust pin in drection B.
- 3) The maximum amount of oil is reached when marker dot A is brought to the position just opposite from the needle bar crank by turning the adjust pin in direction C.

3. ADJUSTING THE AMOUNT OF OIL (OIL SPLASHES IN THE HOOK(Fig,7.8.9)



WARNING:

Be extremely careful about the operation of the machine since the amount of oil has to be checked by turning the hook at a high speed.

① Amount of oil (oil splashes) confirmation paper



• Use any paper available regardless of the material.

Fig. 7

② Position to confirm the amount of oil(oil splashes)

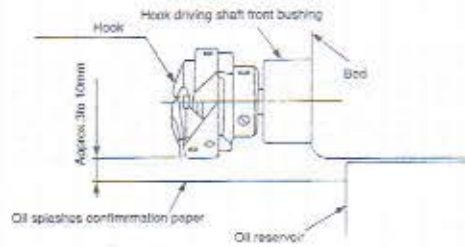

Closely fit the paper against the wall surface of the oil reservoir.
 • Place the amount of oil (oil splashes) confirmation paper under the hook.

*When carrying out the procedure described below in 2), remove the slide plate and take extreme caution not to allow your fingers to come in contact with the hook.

(Cautions 1) If the machine has not been sufficiently warmed up for operation, make the machine run idle for approximately three minutes. (Moderate intermittent operation)

2) Place the amount of oil (oil splashes) confirmation paper under the hook while the sewing machine is in operation

3) Confirm that the height of the oil surface in the oil reservoir is within the range between "HIGH" and "LOW".

4) Confirmation of the amount of oil should be completed in five seconds. (Check the period of time with a watch)

● Sample showing the appropriate amount of oil

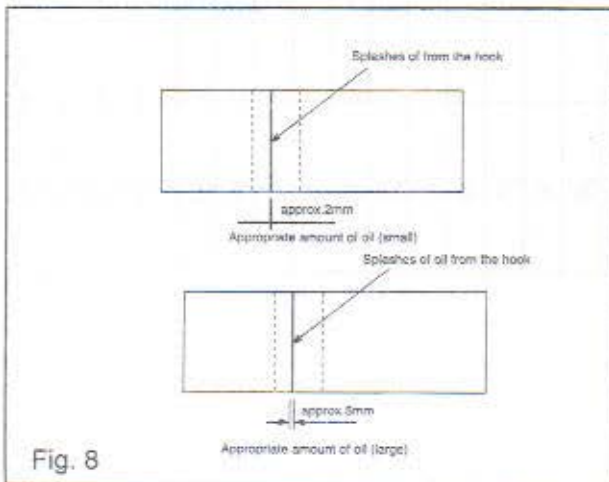

Fig. 8

● Adjusting the amount of oil (oil splashes) in the hook

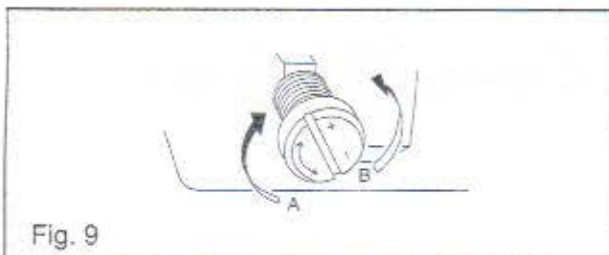

Fig. 9

1) The amount of oil shown is the samples on the left should be finely adjusted in accordance with sewing processes. Be careful not to excessively increase/decrease the amount of oil in the hook. (If the amount of oil is too small, the hook will be seized (the hook will be hot). If the amount of oil is too much, the sewing product may be stained with oil.)

2) Adjust the amount of oil in the hook so that the oil amount (oil splashes) should not change while checking the oil amount three times (on the three sheets of paper).

1) Turning the oil amount adjustment screw mounted on the hook driving shaft front bushing in the "+" direction (in direction A) will increase the amount of oil (oil splashes) in the hook, or in the "-" direction (in direction B) will decrease it.

2) After the amount of oil in the hook has been properly adjusted with the oil amount adjustment screw, make the sewing machine run idle for approximately 30 seconds to check the amount of oil (oil splashes) in the hook.

4. ATTACHING THE NEEDLE (Fig.10)

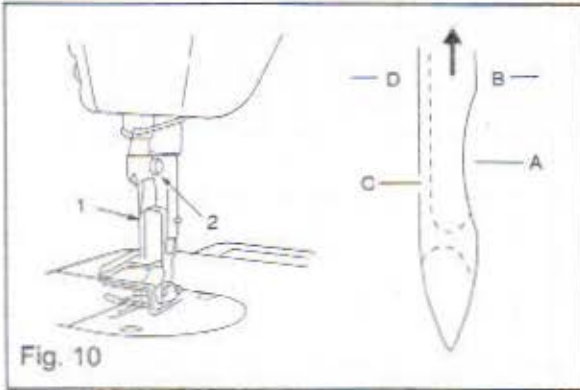

WARNING:

Turn OFF the power before starting the work so as to prevent accidents caused by abrupt start to the sewing machine.

Follow the procedure described below to attach the needle, after confirming that the motor has come to a complete stop.

A needle of DP x 5 should be used, Select a proper needle size according to the count of thread and the type of material used.

- 1) Turn the handwheel until the needle bar reaches the highest point of its stroke.
- 2) Loosen screw ②, and hold needle ① with its indented part A facing exactly to the right in direction B.
- 3) Insert the needle fully into the hole in the needle bar in the direction of the arrow until the end of hole is reached.
- 4) Securely tighten screw ②.
- 5) Check that long groove C of the needle is facing exactly to the left in direction D.

1.Notes: The standard needle for leather is DB*5 (16-23#);

Another standard needle for heavy material is DB*5(16-18#) the standard needle for light material is DB*1(9-18#)

5. SETTING THE BOBBIN INTO THE BOBBIN CASE (Fig.11)

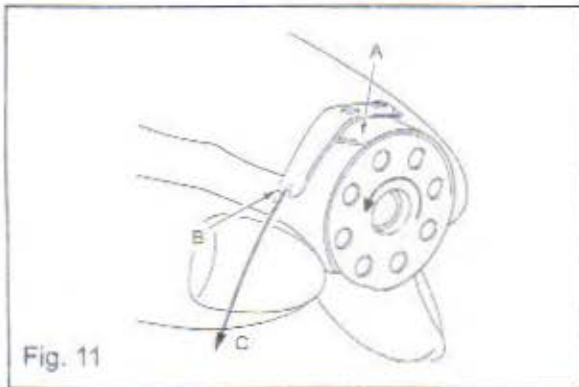

- 1) Install the bobbin in the bobbin case so that the thread wound direction is counterclockwise.
- 2) Pass the thread through thread slit A, and pull the thread in direction B. By so doing, the thread will pass under the tension spring and come out from notch B.
- 3) Check that the bobbin rotates in the direction of the arrow when thread C is pulled.

6. THREADING THE MACHINE HEAD(Fig.12)

The needle bar should be the highest, Then draw a thread end from the thread holder and thread it as follows:

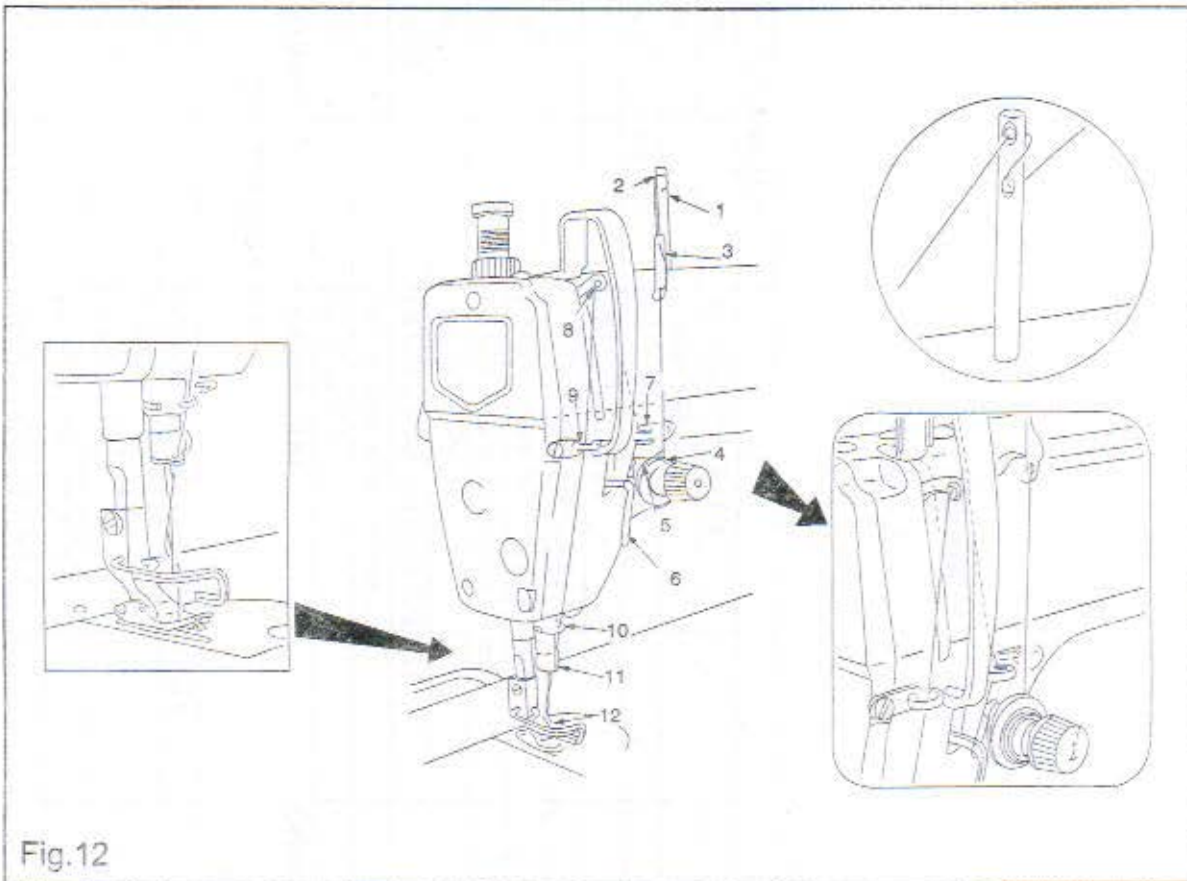

Fig.12

7. ADJUSTING THE STITCH LENGTH (FIG.13)

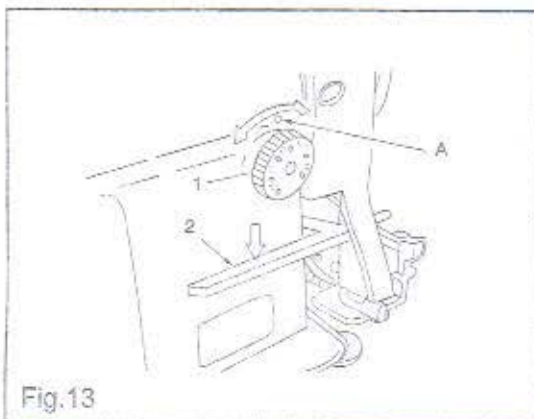

Fig.13

- 1) Turn stitch length dial ① in the direction of the arrow, and align the desired number to marker dot A on the machine arm.
- 2) The dial calibration is in millimeters.
- 3) When you want to decrease the stitch length, turn stitch length dial ① while pressing feed lever ② in the direction of the arrow.

8. THREAD TENSION (Fig.14)

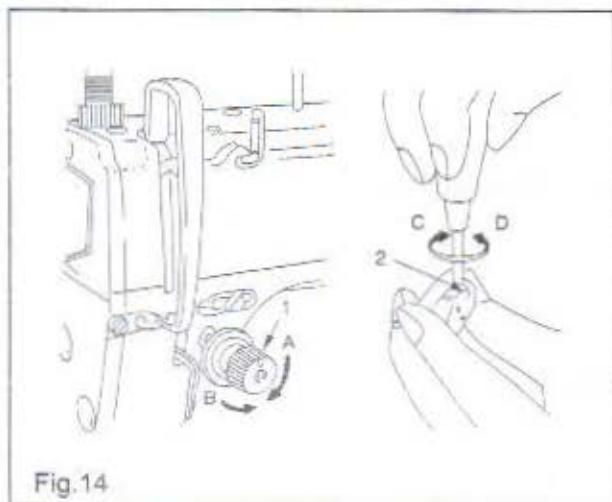

Fig.14

1. Adjusting the needle thread tension

- 1) Adjust the needle thread tension using tension adjust nut ① according to the sewing specifications.
- 2) As you turn nut ① clockwise (in direction A), the needle thread tension will increase.
- 3) As you turn nut ① counterclockwise (in direction B), the tension will decrease.

2. Adjusting the bobbin thread tension

- 1) As you turn tension adjust screw ② clockwise (in direction C), the bobbin thread tension will increase.
- 2) As you turn screw ② counterclockwise (in Direction D), the bobbin thread tension will decrease.

9. THREAD TAKE-UP SPRING (Fig.15)

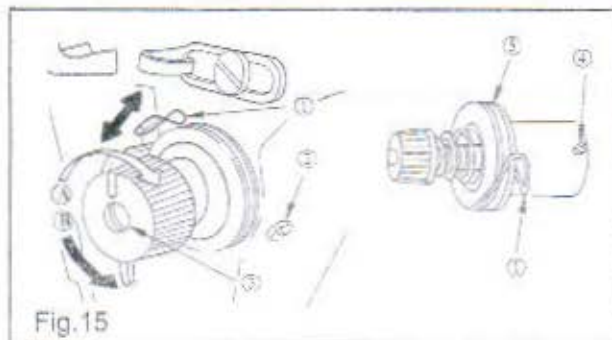

Fig.15

1. The width of take-up spring is 8-10mm. if the sewing material is thin material (short needle width), pls lighten the take-up spring tension and wide the sway of it. Otherwise, pls do to opposition.

2. Changing the stroke of thread take-up spring ①.

- 1) Loosen set screw ②.
- 2) As you turn tension post ③ clockwise (in direction A), the stroke of the thread take-up spring will be increased.

- 3) As you turn the knob counterclockwise (in direction B), the stroke will be decreased.

3. Changing the pressure of thread take-up spring ①.

- 1) Loosen set screw ②, and remove thread tension ①.
 - 2) Loosen set screw ④.
 - 3) As you turn tension post ③ clockwise (in direction A), the pressure will be increased.
 - 4) As you turn the post counterclockwise (in direction B), the pressure will be decreased.
4. Usually, upon the machine coming out, all the take-up spring has been adjusted well. Only while sew special material or special thread, it need to be adjusted again.

10. HAND LIFTER (Fig.16)

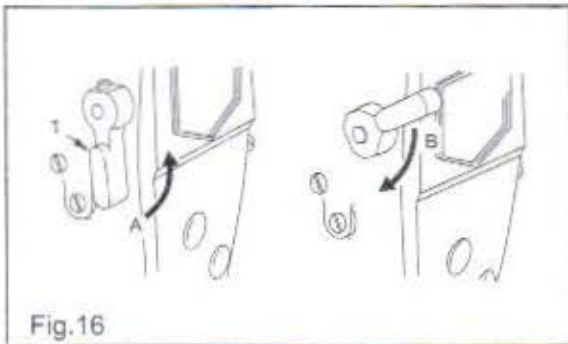

- 1) To stop the machine with its presser foot up, turn hand lifter lever ① in direction A .
- 2) The presser foot will go up about 5.5mm and stop.
The presser foot will go back to its original position when hand lifter lever is turned down in direction B.
- 3) Using the knee lifter, you can get the standard presser foot lift of about 10mm and a maximum lift of about 13mm.

11. PRESSER FOOT PRESSURE(Fig.17)

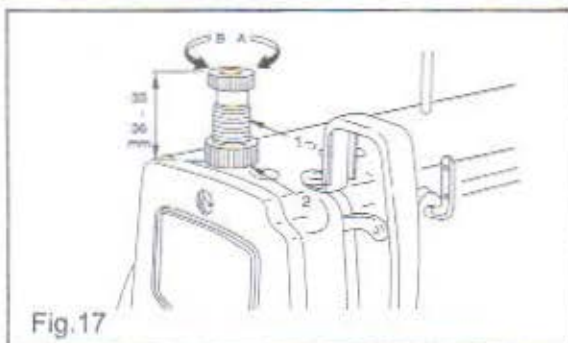

- WARNING:**
Turn OFF the power before starting the work so as to prevent accidents caused by abrupt start of the sewing machine.
- 1) Loosen nut ② . As you turn presser spring regulator ① clockwise (in direction A), the presser foot pressure will be increased.
 - 2) As you turn the presser spring regulator counterclock-wise (in direction B), the pressure will be decreased.
 - 3) After adjustment, tighten nut ② .
 - 4) For general fabrics, the standard height of the presser spring regulator is 33 to 36mm (5 kg).

- WARNING:**
Turn OFF the power before starting the work so as to prevent accidents caused by abrupt start to the sewing machine.

12.ADJUSTING THE FEED TIMING (Fig.18)

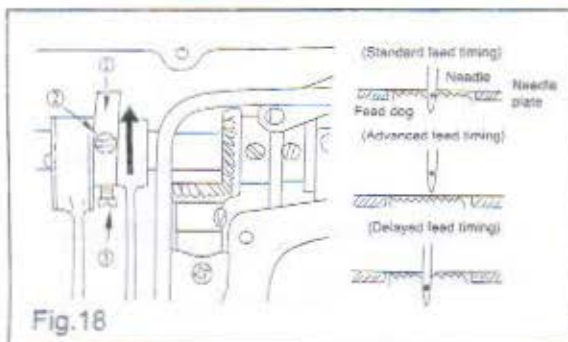

- 1) Loosen screws ② and ③ in feed eccentric cam ① . Move the feed eccentric cam in the direction of the arrow or opposite direction of the arrow, and firmly tighten the screws.
- 2) For the standard adjustment, adjust so that the top surface of feed dog and the top end of needle eyelet are flush with the top surface of throat plate when the feed dog descends below the throat plate.
- 3) To advance the feed timing in order to prevent uneven material feed, move the feed eccentric cam in the direction of the arrow.
- 4) To delay the feed timing in order to increase stitch tightness, move the feed eccentric cam in the opposite direction from the arrow.
- 5) if feed eccentric cam adjust too much, it will cause the broken of needle.

13. HEIGHT OF THE FEED DOG(FIG.19)

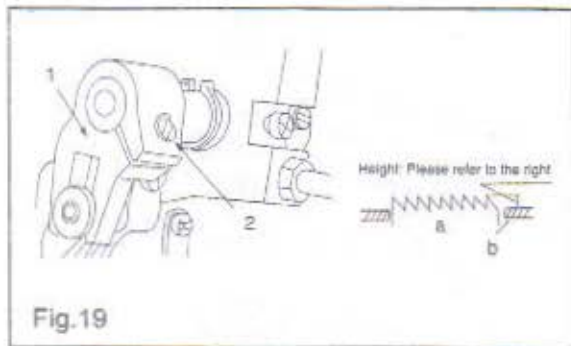

Fig.19



CAUTION:

Be careful not to move the feed eccentric cam too far, or else needle breakage may result.



WARNING:

Turn OFF the power before starting the work so as to prevent accidents caused by abrupt start of the sewing machine.

1) The feed dog is factory-adjusted so that it just out from the throat plate surface 1.15mm to 1.25 mm.

2) To adjust the height of the feed dog:

① Loosen screw ② of crank ①.

② Move the feed bar up or down to make adjustment.

③ Securely tighten screw ②.

(Caution) If the clamping pressure is insufficient, the forked portion will wear out.

a. Feed dog b. Needle plate

3). The feed dog for leather heavy material must be adjusted 1.15-1.25mm higher than needle plate. The feed dog for mid-heavy material must be 0.8-0.9 mm higher than needle plate, while sew thin material, the suitable height is 0.7-0.8mm.

14.NEEDLE-TO-HOOK RELATIONSHIP (Fig.20)

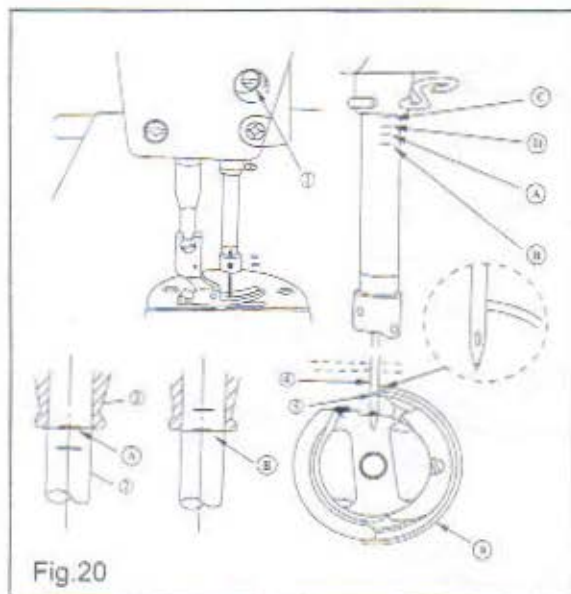

Fig.20



WARNING:

Turn OFF the power before starting the work so as to prevent accidents caused by abrupt start to the sewing machine.

1.Adjust the timing between the needle and the hook as follows.

1) Turn the handwheel to bring the needle bar down to the lowest point of its stroke, and loosen set screw ①.

(Adjusting the needle bar height)

2) Locate the needle height

a. while using DB needle, align marker line A with the bottom end of needle bar lower bushing 3, then tighten set screw 1.

b. While using DA needle, align mark line C with the bottom end of needle bar lower bushing 3, then tighten set screw 1.

3) Locate the hook position.

a. While using DB needle, loosen the two hook set screws, turn the hand wheel, and align marker line B on ascending needle bar 2 with the bottom end of needle bar lower bushing 3.

b. While using DA needle, loosen the two hook set screw, turn the hand wheel, and align marker line D on ascending needle bar 2 with the bottom end of needle bar lower bushing 3.

4) After making the adjustments mentioned in the above steps, align hook blade point ⑤ with the center of needle ④. Provide a clearance of 0.06mm to 0.15mm (reference value) between the needle and the hook, then securely tighten setscrews in the hook.

(Caution) 1. If the clearance between the blade point of hook and the needle is

smaller than the specified value, the blade point of hook will be damaged. If the clearance is larger, stitch skip-ping will result.

2. Use a hook of the same part No. when replacing your hook with a new one.

15. ADJUSTING THE HEIGHT OF THE PRESSER FOOT (Fig.21)



Fig.21



WARNING:

Turn OFF the power before starting the work so as to prevent accidents caused by abrupt start of the sewing machine.

- 1) Loosen setscrew ①. And adjust the presser foot height and the angle of the presser foot.
- 2) After adjustment, securely tighten the set screw ①.

16. ADJUSTING THE THREAD TAKE-UP STROKE(Fig.22)

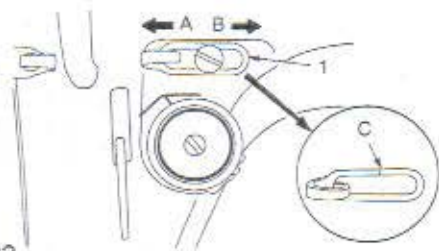

Fig.22



WARNING:

Turn OFF the power before starting the work so as to prevent accidents caused by abrupt start of the sewing machine.

- 1) When sewing heavy-weight materials, move thread guide ① to the left in direction A to increase the length of thread pulled out by the thread take-up.
- 2) When sewing light-weight materials, move thread guide ① to the right in direction B to decrease the length of thread pulled out by the thread take-up.
- 3) Normally, thread guide ① is positioned in a way that marker line C is aligned with the center of the screw.

17. INSTALLING THE BELT COVER AND THE BOBBIN WINDER(Fig.23,24,25)

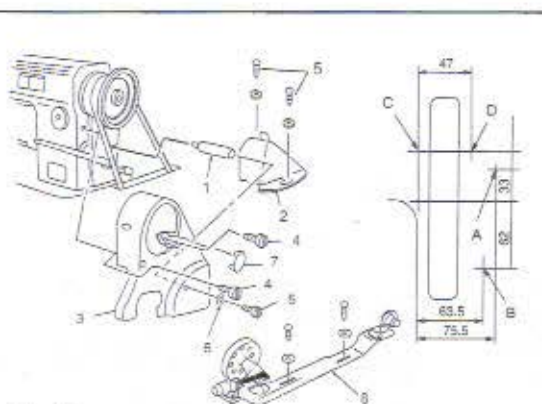

Fig.23

1. Installation procedure

- 1) Drill four guiding holes A, B, C and D for wooden screws in the table.
- 2) Install belt cover support ① in the tapped hole in arm.
- 3) Pass the handwheel through the hole in belt cover A ③, then set the handwheel on the arm. At this time, you can smoothly install the handwheel diagonally from the rear of the handwheel by tilting belt cover A ③ as illustrated in the figure.
- 4) Place belt cover B ② on guiding holes C and D.
- 5) Fix belt cover A ③ on the arm using screws ④, ⑤ and washer ⑥, At this time, tighten screw ④ with a tightening torque of

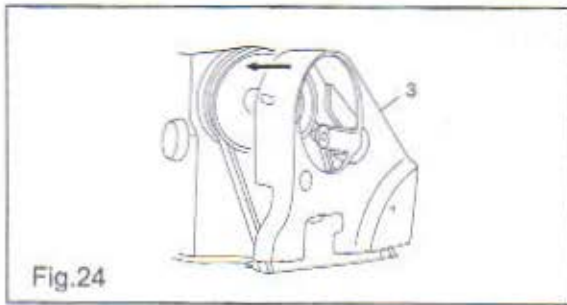

Fig.24

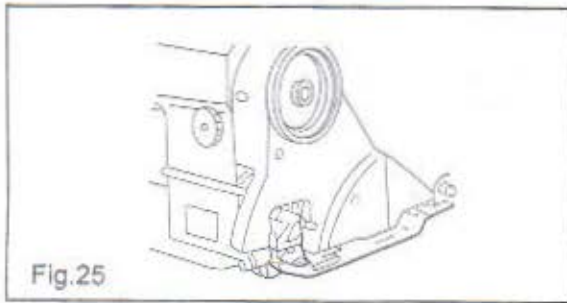

Fig.25

of 30 kgf/cm and screw ⑤ with a tightening torque of 25 kgf/cm. If you tighten further these screws, the securing state of the belt cover will not change.

- 6) Fit cat ⑦ to the belt cover A .
- 7) Move belt cover B ② backward E until the rubber section of belt cover B ② comes in contact with belt cover A ③ . Then, further move the belt cover B in the same direction by 0.5 to 1 mm. Now, fix the belt cover B in position using wooden screw and washer.
- 8) Fix bobbin winder ⑧ in guiding holes A and B using wooden screws and washers.

Warnings: 1) For safety's needs, belt cover should be installed.

- 2) The left and right parts of the bobbin winder should be parallel to the plate belt holes.

18. ADJUSTING THE HEIGHT OF THE KNEE LIFTER (Fig.26,27)

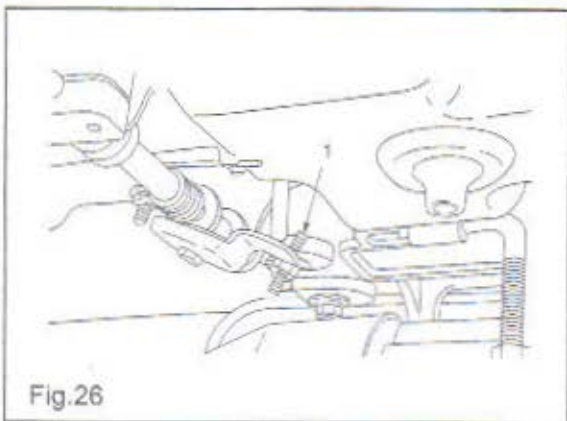

Fig.26



WARNING:

Turn OFF the power before starting the work so as to prevent accidents caused by abrupt start of the sewing machine.

- 1) The standard height of the presser foot lifted using the knee lifter is 10mm.
- 2) You can adjust the presser foot lift up to 13mm using knee lifter adjust screw ① .
- 3) When you have adjusted the presser foot lift to over 10mm, be sure that the bottom end of needle bar ② in its lowest position does not hit presser foot ③ .

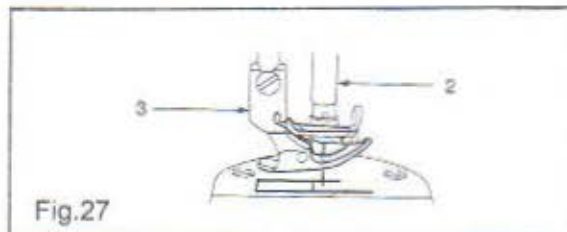

Fig.27

19. SPECIFICATIONS

Application		For Light medium-heavy materials	For heavy materials	For Leather materials
Max Sewing Speed		5500 RPM	3000 RPM	3000 RPM
Max Stitch Length		5 mm	8 mm	8 mm
Lifting height of presser foot	Hand Lifter	6mm(MAX.)	6mm(MAX.)	8mm(MAX.)
	Knee Lifter	13mm(MAX.)	13mm(MAX.)	13mm(MAX.)
Needle		DBX1 9# ~ 18#	DPX5 16# ~ 18#	DPX5 20# ~ 23#
Lubrication oil		White oil No.10		
Motor power		370W		

1. While Sewing Light materials, the machine need to change the presser foot, needle bar and feed dog and do some adjustment.
2. Machine with "R" added is using roller presser foot.

To order or for further information, please contact:

- * Please do not hesitate to contact our distributors or agents in your areas for further information when necessary.
- * The description covered in this instruction manual is subject to change for improvement of the commodity without notice.

零件手册

PARTS BOOK

- 1、此样本为2001年12月重新修订本。

It was a new-revised endition in December, 2001.

- 2、型号后带 R 字母为滚轮压脚。

The machine with "R" added is using roller presser foot.

- 3、选购零部件时，请注明序号、件号。

Please confirm the relative applications Ref.No, part no .

When buying the parts.

目 录

CONTENTS

1、机壳分组件 Machine Frame & Miscellaneous Cover Components	28
2、主轴及挑线杆分组件 Main Shaft & Thread Take-up Lever Components	31
3、针杆、竖轴及旋梭驱动轴分组件 Needle Bar、Upright Shaft & Hook Driving Shaft Components	33
4、压脚分组件 Presser Foot Components	36
5、送料分组件 Feed Mechanism Components	38
6、润滑分组件 Oil Lubrication Components	41
7、油盘分组件 Oil Reservoir Components	43
8、皮带罩、绕线器与过线架分组件 Belt Cover、Bobbin Winder & Thread Stand Components	45
9、型号R滚轮压脚专用件Model "R" Presser Rollar Special Accessory.....	48
10、附件 Accessories.....	50

1. 机壳分组件 Machine frame & miscellaneous cover components

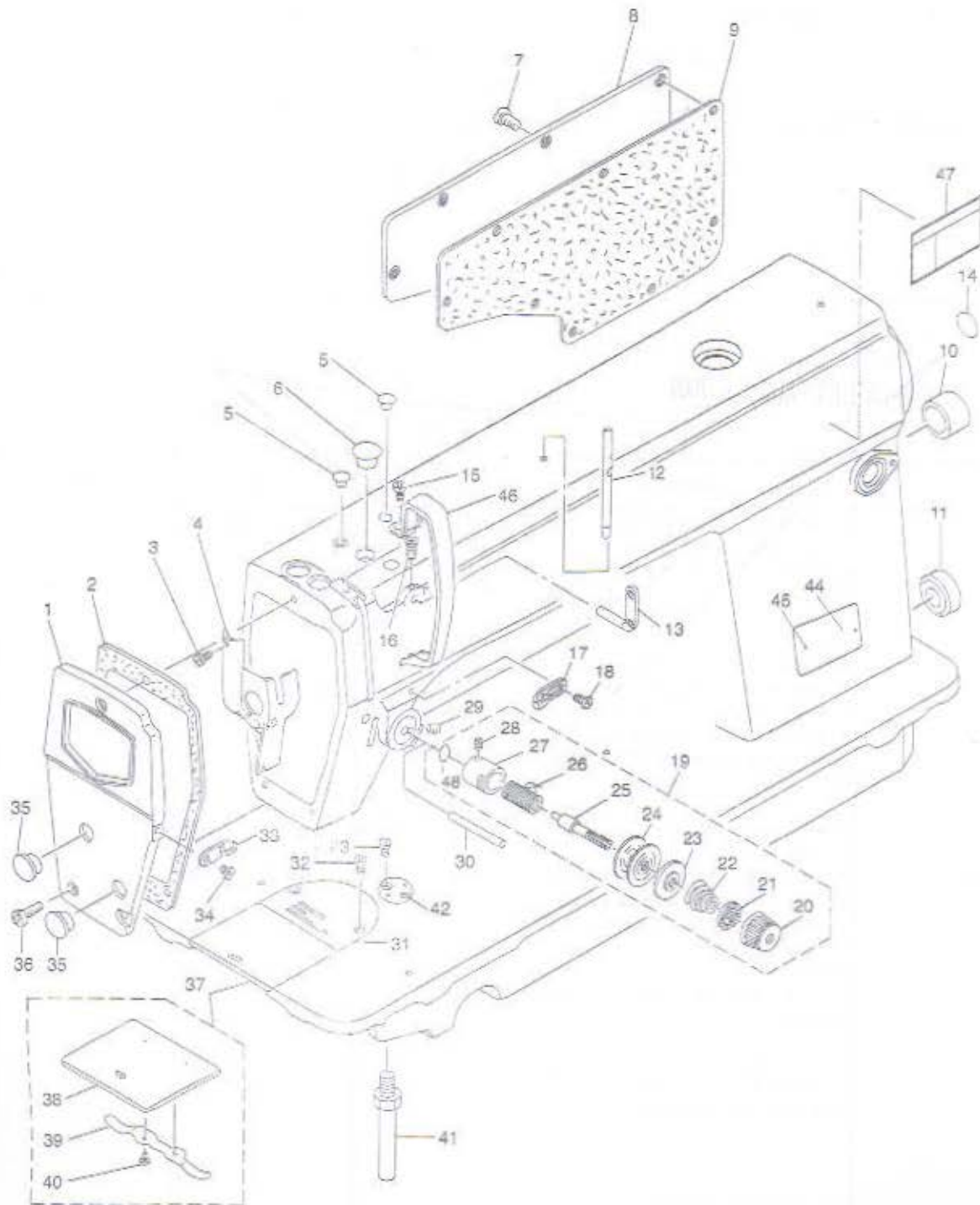

No.	PART No.	DESCRIPTION	QTY	medium-heavy materials	For heavy materials	leather materials
1	GR581-8	面板 Face plate ASM.	1	☆	☆	☆
2	GR582-8	面板垫 Face plate gasket	1	☆	☆	☆
3	GS159-8	防油板螺钉SM1/8"×44 L=4 Screw 1/8"×44 L=4	1	☆	☆	☆
4	GR679/2-8	面板防油板零件 ARM oil shield ASM.	1	☆	☆	☆
5	GR585-8	挑线连杆销螺孔塞 Rubber plug	2	☆	☆	☆
6	GR584-8	针杆曲柄螺孔塞 Rubber plug	1	☆	☆	☆
7	GS300-8	后窗板螺钉SM3/16"×28L=9 Screw 3/16"×28 L=9	8	☆	☆	☆
8	GR578-8	后窗板 Side plate	1	☆	☆	☆
9	GR579-8	后窗板垫 Gasket	1	☆	☆	☆
10	GR586-8	送料调节器孔塞 Rubber plug	1	☆	☆	☆
11	GR587-8	下轴孔塞 Rubber plug	1	☆	☆	☆
12	GR611-8	过线柱 Needle thread guide pin	1	☆		
	GR800-8	过线柱 Needle thread guide pin	1		☆	☆
13	GR602-8	三眼线钩 Three-hole thread eyelet	1	☆	☆	☆
14	GQ200-8	接地指示牌 Earthing indication plate	1	☆	☆	☆
15	GS310-8	挑线杯罩螺钉SM3/16"×28 L=6 Screw 3/16"×28 L=6	1	☆	☆	☆
16	GS310-8	三眼线钩螺钉SM3/16"×28 L=6 Screw 3/16"×28 L=6	1	☆	☆	☆
17	GR603-8	右线钩 Arm thread guide-Right	1	☆	☆	☆
18	GS313-8	右线钩螺钉SM11/64"×40 L=6 Screw 11/64"×40 L=6	1	☆	☆	☆
19		夹线器组件 Thread tension ASM.	1	☆	☆	☆
20	GL167-8	夹线螺母 Tension nut	1	☆	☆	☆
21	GR609-8	夹线制动板 Tension Disc stopper	1	☆	☆	☆
22	GW184-8	夹线簧 Tension spring	1	☆		
	GW202-8	夹线簧 Tension spring	1		☆	☆
23	GR608-8	松线板 Tension Disc holder	1	☆	☆	☆
24	GR607-8	夹线板 Tension Disc	2	☆	☆	☆
25	GS314-8	夹线螺钉 Screw	1	☆	☆	☆
26	GW183-8	挑线簧 Take-up spring	1	☆	☆	☆
27	GR606-8	挑线簧调节座 Tesion post socket	1	☆	☆	☆
28	GS315-8	夹线螺钉紧固螺钉SM9/64" Screw 9/64"	1	☆	☆	☆
29	GS316-8	夹线器螺钉 Screw	1	☆	☆	☆
30	GX200-8	松线钉 Thread release pin	1	☆	☆	☆
31	GM166-8	针板 Needle plate	1	☆		
	GM173-8	针板 Needle plate	1		☆	☆
32	GS338-8	针板螺钉11/64"×40L=8.5 Screw 11/64"×40 L=8.5	2		☆	☆
33	GR604-8	左线钩 ARM thread guide-left	1	☆	☆	☆
34	GS313-8	左线钩螺钉11/64"×40L=6 Screw 11/64"×40 L=6	1	☆	☆	☆
35	GR583-8	面板调节螺孔塞 Rubber plug	2	☆	☆	☆
36	GS300-8	面板螺钉3/16"×28 L=9 Screw 3/16"×28 L=9	3	☆	☆	☆
37	GM167/4-8	推板部件 Bed slide ASM.	1	☆	☆	☆
38	GM168-8	推板 Slide plate	1	☆	☆	☆
39	GW190-8	推板簧 Spring of slide plate	1	☆	☆	☆

1、机壳分组件 Machine frame & miscellaneous cover components
 1、机壳分组件 Machine frame & miscellaneous cover components

序号 REF. No.	件号 PART No.	名称 DESCRIPTION	数量 QTY	薄、中厚料 For Light medium-heavy materials	厚料 For heavy materials	皮革料 For leather materials
40	GS339-8	推板簧螺钉3/32"×56 L=1.9 Screw 3/32"×56 L=1.9	2	☆	☆	☆
41	GS299-8	底板支柱 Bed screw STUD	4	☆	☆	☆
42	GR724-8	限位挡片 Ruler plate	1	☆	☆	☆
43	GS373-8	限位挡片螺钉 Ruler plate screw	2	☆	☆	☆
44	GQ195-8	型号牌 Model plate	1	☆		
	GQ228-8	型号牌 Model plate	1		☆	
	GQ218-8	型号牌 Model plate	1			☆
45	GX196-8	型号牌铆钉 Pole	2	☆	☆	☆
46	GK153-5	挑线杆防护罩 Thread take-up lever cover	1	☆		
	GK162-8	挑线杆防护罩 Thread take-up lever cover	1		☆	☆
47	GQ196-8	安全指示牌 Safety-indicating plate	1	☆	☆	☆
48	GR1428-8	O型圈 Rubber ring	1	☆	☆	☆

2. 主轴及挑线杆分组件 Main shaft & thread take-up lever components

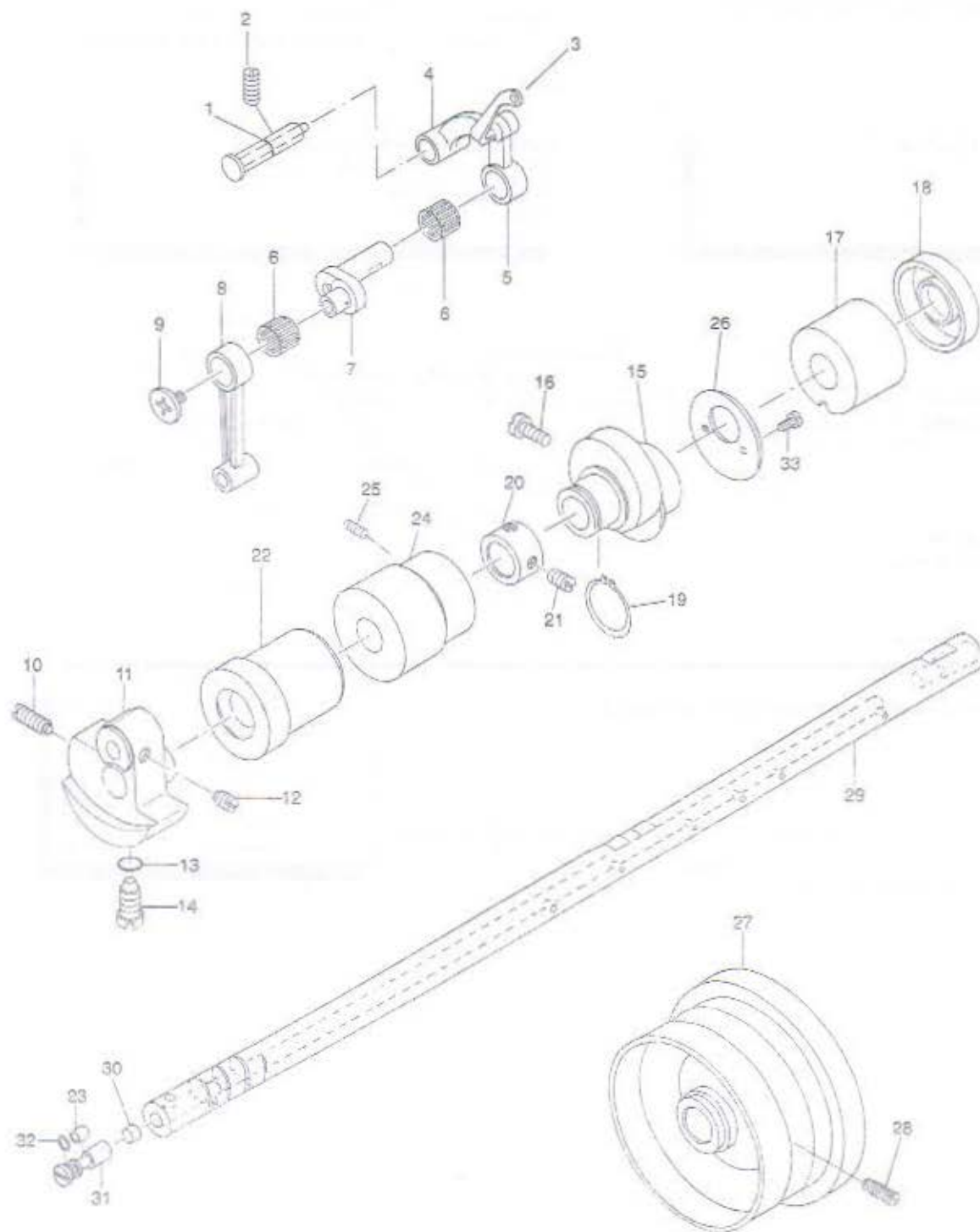

2、主轴及挑线杆分组件 Main shaft & thread take-up lever components

序号 REF. No.	件号 PART No.	名称 DESCRIPTION	数量 QTY	薄、中厚料 For Light medium-heavy materials	厚料 For heavy materials	皮革料 For leather materials
1	GX199-8	挑线连杆销部件 Thread take-up crank shaft	1	☆		
	GR596/2-8	挑线连杆销部件 Thread take-up crank shaft	1		☆	☆
2	GS308-8	挑线连杆销螺钉15/64×28L=105 Screw 15/64×28L=105	1	☆	☆	☆
3	GR595-8	挑线杆防油套 Oil resistant cover	1	☆	☆	☆
4	GH212-8	挑线连杆 Thread take-up bar	1	☆		
	GH358-8	挑线连杆 Thread take-up bar	1		☆	☆
5	GH210/4-8	挑线连杆分组件 Thread take-up lever ASM	1	☆		
	GH350/4-8	挑线连杆分组件 Thread take-up lever ASM	1		☆	☆
6	G0265-8	挑线杆滚针轴承 Needle bearing	2	☆	☆	☆
7	GH208/2-8	挑线曲柄部件 Needle bar crank	1	☆		
	GH352/2-8	挑线曲柄部件 Needle bar crank	1		☆	☆
8	GH213-8	针杆连杆 Needle bar crank rod	1	☆	☆	☆
9	GS309-8	挑线曲柄左端螺钉9/64×40L=4.8 End screw left 9/64×40L=4.8	1	☆	☆	☆
10	GS307-8	针杆曲柄紧固螺钉9/32×28 L=16 Screw 9/32×28 L=16	1	☆	☆	☆
11	GH349-8	针杆曲柄 Counter weight	1	☆		☆
	GH207-8	针杆曲柄 Counter weight	1		☆	
12	GR167-8	挑线曲柄定位螺钉1/40×40 L=6 Screw 1/40×40 L=6	2	☆	☆	☆
13	GR592-8	定位螺钉O型圈 Rubber ring	1	☆	☆	☆
14	GS371-8	针杆曲柄定位螺钉9/32×28 L= Screw 9/32×28 L=	1	☆	☆	☆
15	GT156-8	送料偏心轮 Feed drive eccentric cam	1	☆		
	GT159-8	送料偏心轮 Feed drive eccentric cam	1		☆	☆
16	GS332-8	送料偏心轮螺钉1/4×40 L=11 Screw 1/4×40 L=11	2	☆	☆	☆
17	G0256-8	上轴后轴套 Main shaft rear bushing	1	☆	☆	☆
18	GR588-8	上轴油封 Oil seal	1	☆	☆	☆
19	GR650-8	拾牙连打轴用挡圈 Snap ring	1	☆	☆	☆
20	GR589-8	上轴挡圈 Thrust collar	1	☆	☆	☆
21	GS305-8	上轴挡圈螺钉1/40"×40 L=6 Screw 1/40"×40 L=6	2	☆	☆	☆
22	G0259-8	上轴前轴套 Main shaft front bushing	1	☆	☆	☆
23	GX198-8	曲柄油量调节销 Oil amount adjusting pin	1	☆	☆	☆
24	G0258-8	上轴中轴套 Intermediate bushing	1	☆	☆	☆
25	GS306-8	上轴中轴套螺钉 Screw	2	☆	☆	☆
26	GR638-8	送料偏心轮盖板 Thrust collar	1	☆		
	GR808-8	送料偏心轮盖板 Thrust collar	1		☆	☆
27	GP147-8	上轮 Hand wheel	1	☆	☆	
	GP157-8	上轮 Hand wheel	1			☆
28	GS304-8	上轮螺钉 Screw	1	☆	☆	☆
29	GZ229-8	上轴 Main shaft	1	☆	☆	☆
30	GR590-8	曲柄油量限制毡 Roller felt	1	☆	☆	☆
31	G0261-8	曲柄油量调节销套 Sleeve of oil amount adjusting pin	1	☆	☆	☆
32	GR591-8	曲柄油量调节销O型圈 O-ring	1	☆	☆	☆
33	GS311-8	偏心轮盖板螺钉9/64×40 L=6 Screw 9/64×40 L=6	2	☆	☆	☆

3、针杆、竖轴及旋梭驱动轴分组件 Needle bar, upright shaft & hook driving shaft components

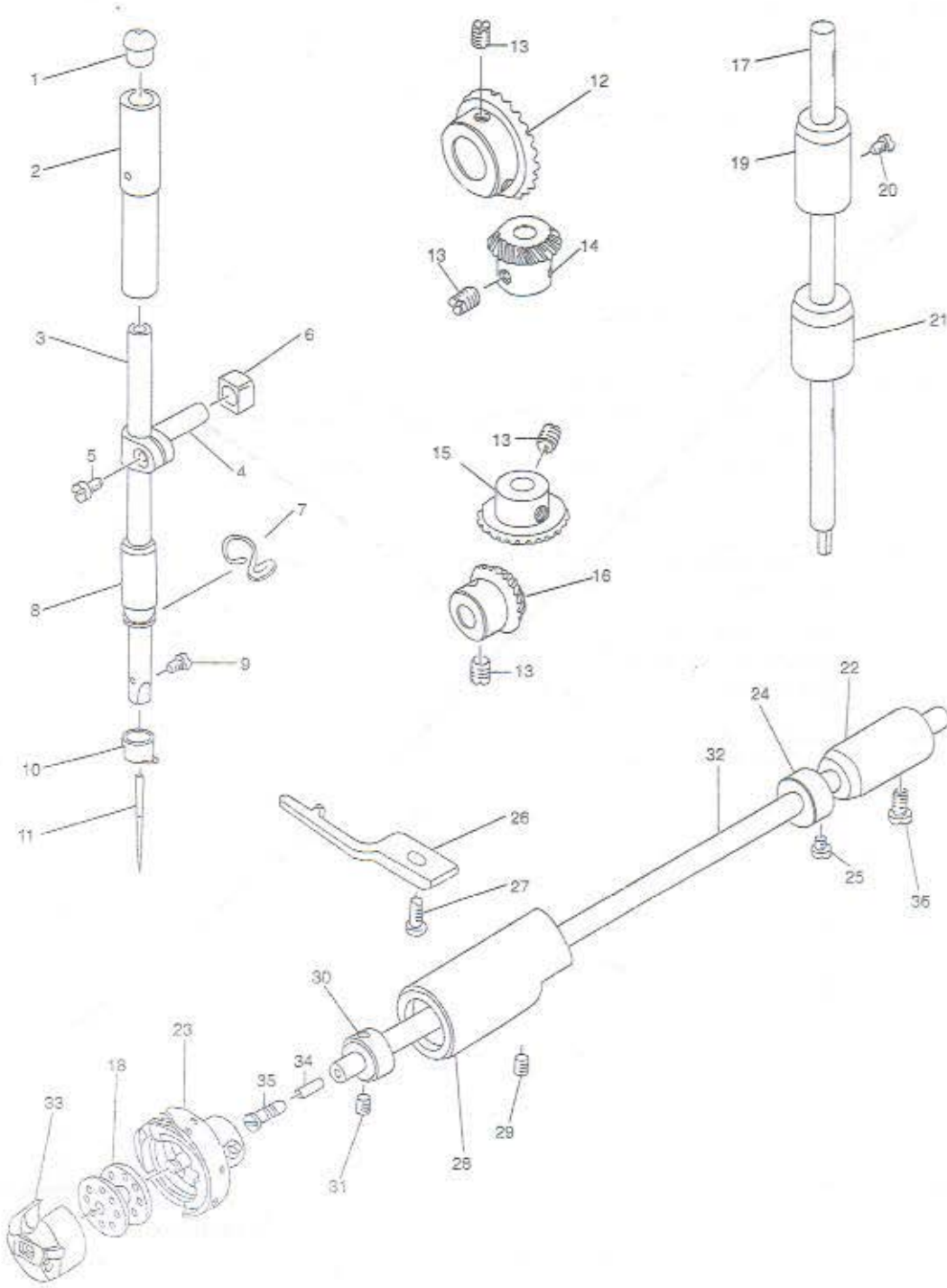

3. 针杆、竖轴及旋梭驱动轴分组件 Needle bar, upright shaft & hook driving shaft components

序号 REF. No.	件号 PART No.	名称 DESCRIPTION	数量 QTY	薄、中厚料 For Light medium-heavy materials	厚料 For heavy materials	皮革料 For leather materials
1	GR599-8	针杆上轴套孔塞 Cap	1	☆	☆	☆
2	GO266-8	针杆上轴套 Needle bar upper bushing	1	☆	☆	☆
3	GZ230-8	针杆 Needle bar	1	☆		
	GZ251-8	针杆 Needle bar	1		☆	☆
4	GR598-8	针杆连接柱 Needle bar connecting-rod	1	☆	☆	☆
5	GS311-8	针杆连接柱螺钉9/64×40L=6 Screw 9/64×40L=6	1	☆	☆	☆
6	GU152-8	针杆连接柱滑块 Slide block	1	☆	☆	☆
7	GR600-8	针杆下轴套线钩 Needle bar thread guide	1	☆		
	GR801-8	针杆下轴套线钩 Needle bar thread guide	1		☆	☆
8	GO267-8	针杆下轴套 Needle bar lower bushing	1	☆		
	GO289-8	针杆下轴套 Needle bar lower bushing	1		☆	☆
9	GS312-8	支针螺钉1/8×44L=4.5 Screw 1/8×44L=4.5	1	☆	☆	☆
10	GR601-8	针杆线钩 Needle bar thread guide	1	☆		
	GR802-8	针杆线钩 Needle bar thread guide	1		☆	☆
11	GV132-8	机针 (DB×1) Needle DB×1	1	☆		
	GV134-8	机针 (DB×5) Needle DB×5	1		☆	☆
12	GC157-8	上轴伞齿轮 (大) Gear of main shaft (big)	1	☆	☆	☆
13	GS319-8	伞齿轮螺钉1/4×40L=8 Screw 1/4×40L=8	8	☆	☆	☆
14	GC156-8	竖轴上伞齿轮 (小) Gear of upright shaft (small)	1	☆	☆	☆
15	GC155-8	竖轴下伞齿轮 (大) Gear of upright shaft (big)	1	☆	☆	☆
16	GC154-8	下轴伞齿轮 (小) Gear of hook driving shaft (small)	1	☆	☆	☆
17	GZ234-8	竖轴 Upright shaft	1	☆	☆	
	GZ255-8	竖轴 Upright shaft	1			☆
18	GN139-8	梭心 Bobbin	1	☆		
	GN566-8	梭心 Bobbin	1		☆	☆
19	GO272-8	竖轴上轴套 Upper bushing	1	☆	☆	☆
20	GS403-8	竖轴上轴套螺钉3/16×28L=9 Screw 3/16×28L=9	1	☆	☆	☆
21	GO271-8	竖轴下轴套 Upright shaft lower bushing	1	☆	☆	☆
22	GO270-8	下轴后轴套 Rear bushing	1	☆	☆	☆
23	GN137-8	旋梭 Hook	1	☆	☆	
		旋梭 Hook	1			☆
24	GR636-8	下轴挡圈 Thrust collar	1	☆	☆	☆
25	GS331-8	下轴挡圈螺钉11/64×40L=4.8 Screw 11/64×40L=4.8	2	☆	☆	☆
26	GR631-8	旋梭定位钩 Positioning finger	1	☆		
	GR818-8	旋梭定位钩 Positioning finger	1		☆	☆
27	GS328-8	旋梭定位钩螺钉11/64×40L=9.5 Screw 11/64×40L=9.5	1	☆	☆	☆
28	GO269-8	下轴前轴套 Front bushing	1	☆	☆	
	GO291-8	下轴前轴套 Front bushing	1			☆
29	GS316-8	下轴前轴套螺钉 Screw	1	☆		
	GS414-8	下轴前轴套螺钉 Screw	1		☆	☆
30	GR634-8	下轴挡油圈 Thrust collar	1	☆	☆	☆
31	GS330-8	下轴挡油圈螺钉11/64×40L=3.5 Crew 11/64×40L=3.5	2	☆	☆	☆

3. 针杆、竖轴及旋梭驱动轴分组件 Needle bar, upright shaft & hook driving shaft components

序号 REF. No.	件号 PART No.	名称 DESCRIPTION	数量 QTY	薄、中厚料 For Light medium-heavy materials	厚料 For heavy materials	皮革料 For leather materials
32	GR233-8	下轴 Hook driving shaft	1	☆	☆	
	GR252-8	下轴 Hook driving shaft	1			☆
33	GN138-8	梭壳 Bobbin case	1	☆	☆	
		梭壳 Bobbin case	1			☆
34	GR633-8	下轴限油芯 Oil wick	1	☆	☆	☆
35	GS329-8	下轴限油螺钉 Screw	1	☆	☆	☆
36	GS402-8	下轴后轴套螺钉3/16×28L=12 Screw 3/16×28L=12	1	☆	☆	☆

4、压脚分组件 Presser foot components

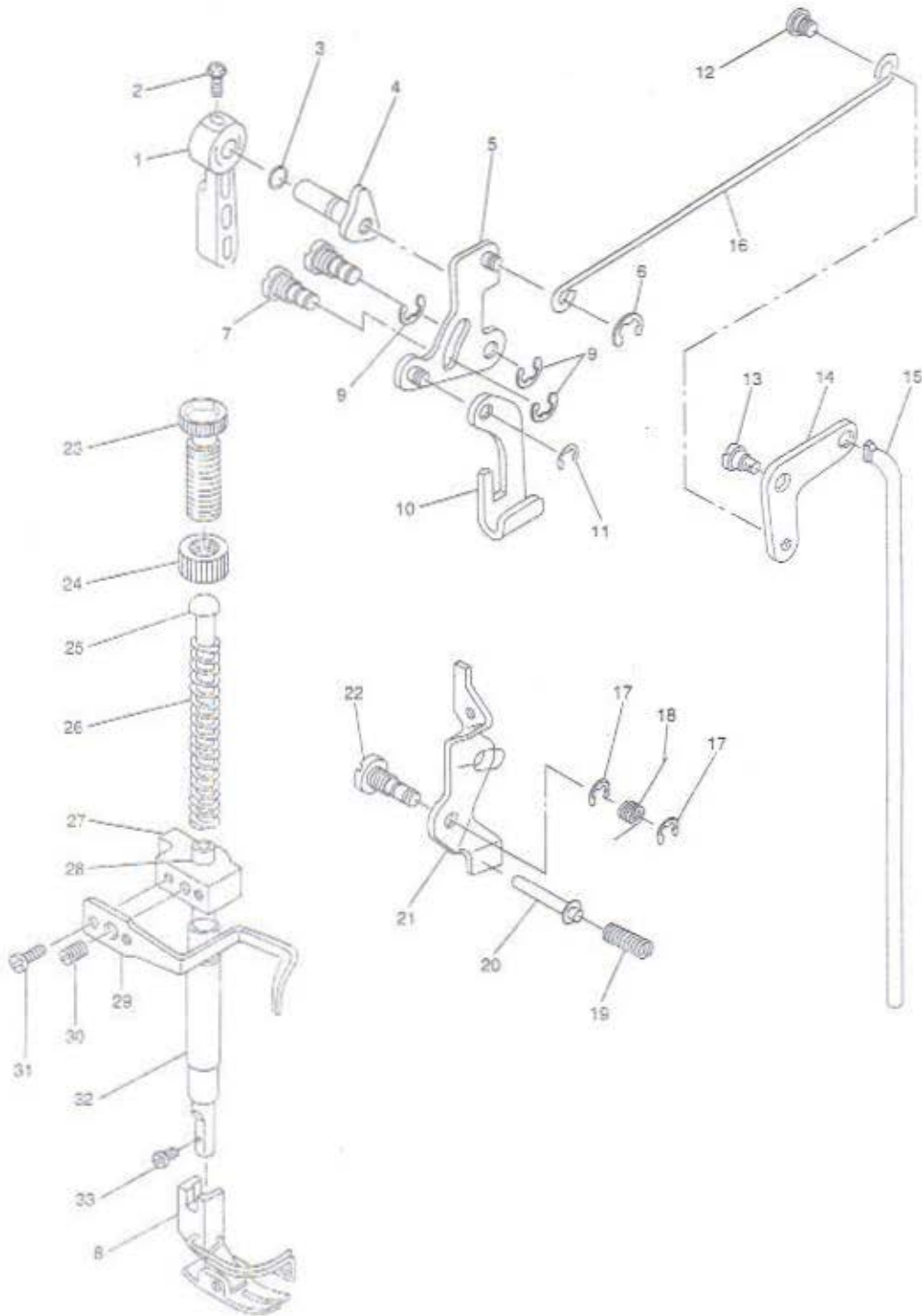

4. 压脚分组件 Presser foot components

序号 REF. No.	件号 PART No.	名称 DESCRIPTION	数量 QTY	薄、中厚料 For Light medium-heavy materials	厚料 For heavy materials	皮革料 For leather materials
1	GR619-8	压脚扳手 Hand lifter	1	☆	☆	☆
2	GS322-8	压脚扳手螺钉 Screw	1	☆	☆	☆
3	GR621-8	压脚扳手轴O型圈 Rubber ring	1	☆	☆	☆
4	GR620/2-8	压脚扳手凸轮部件 Hand lifter cam	1	☆	☆	☆
5	GR623/3-8	抬压脚前杠杆部件 Hand lifter link	1	☆	☆	☆
6	GR625-8	拉杆开口挡圈 Snap ring	1	☆	☆	☆
7	GS323-8	前杠杆螺纹销 Link shaft	2	☆	☆	☆
8	GM164/5-8	活压脚部件 Presser foot ASM	1	☆		
	GR803/5-8	活压脚部件 Presser foot ASM	1		☆	☆
9	GR625-8	螺纹销开口挡圈 Snap ring	3	☆	☆	☆
10	GR622-8	压脚升降板 Lifting lever	1	☆	☆	☆
11	GR626-8	升降板连接开口挡圈 Lifting lever ring	1	☆	☆	☆
12	GS326-8	抬压脚拉杆螺钉 Hinge screw	1	☆	☆	☆
13	GS325-8	后杠杆轴拉螺钉 Hinge screw	1	☆	☆	☆
14	GR629-8	抬压脚后杠杆 Lifting level link	1	☆	☆	☆
15	GR630-8	抬压脚顶杆 Connecting rod vertical	1	☆	☆	☆
16	GR628-8	抬压脚拉杆 Lifting level connecting rod	1	☆	☆	☆
17	GR625-8	螺纹销开口挡圈 Snap ring	2	☆	☆	☆
18	GW189-8	松线顶板复位簧 Tension release return spring	1	☆	☆	☆
19	GW185-8	松线辅钉弹簧 Tension release pin spring	1	☆	☆	☆
20	GX201-8	松线辅钉 Tension release supporting pin	1	☆	☆	☆
21	GR627-8	松线顶板 Tension release plate	1	☆	☆	☆
22	GR324-8	松线顶板螺纹销 Tension release shaft	1	☆	☆	☆
23	GS318-8	调压螺钉 Presser spring regulation	1	☆	☆	☆
24	GL168-8	调压螺母 Nut	1	☆	☆	☆
25	GR613-8	调压导杆 Presser guide bar	1	☆	☆	☆
26	GW253-8	调压簧 Presser spring	1	☆		
	GW203-8	调压簧 Presser spring	1		☆	☆
27	GR614-8	压杆导架 Presser bar guide bracket	1	☆	☆	☆
28	GZ231-8	压杆 Presser bar	1	☆	☆	☆
29	GR615-8	缓线调节钩 Presser bar thread guide	1	☆	☆	☆
30	GS319-8	压杆导架螺钉1/40×40L=8 Screw 1/4×40L=8	1	☆	☆	☆
31	GS320-8	缓线调节钩螺钉9/64×40L=8.5 Screw 9/64×40L=8.5	2	☆	☆	☆
32	GO268-8	压杆轴套 Presser bar lower bushing	1	☆		
	GO290-8	压杆轴套 Presser bar lower bushing	1		☆	☆
33	GS321-8	活压脚螺钉9/64×40L=10.5 Screw 9/64×40L=10.5	1	☆	☆	☆

5、送料分组件 Feed mechanism components

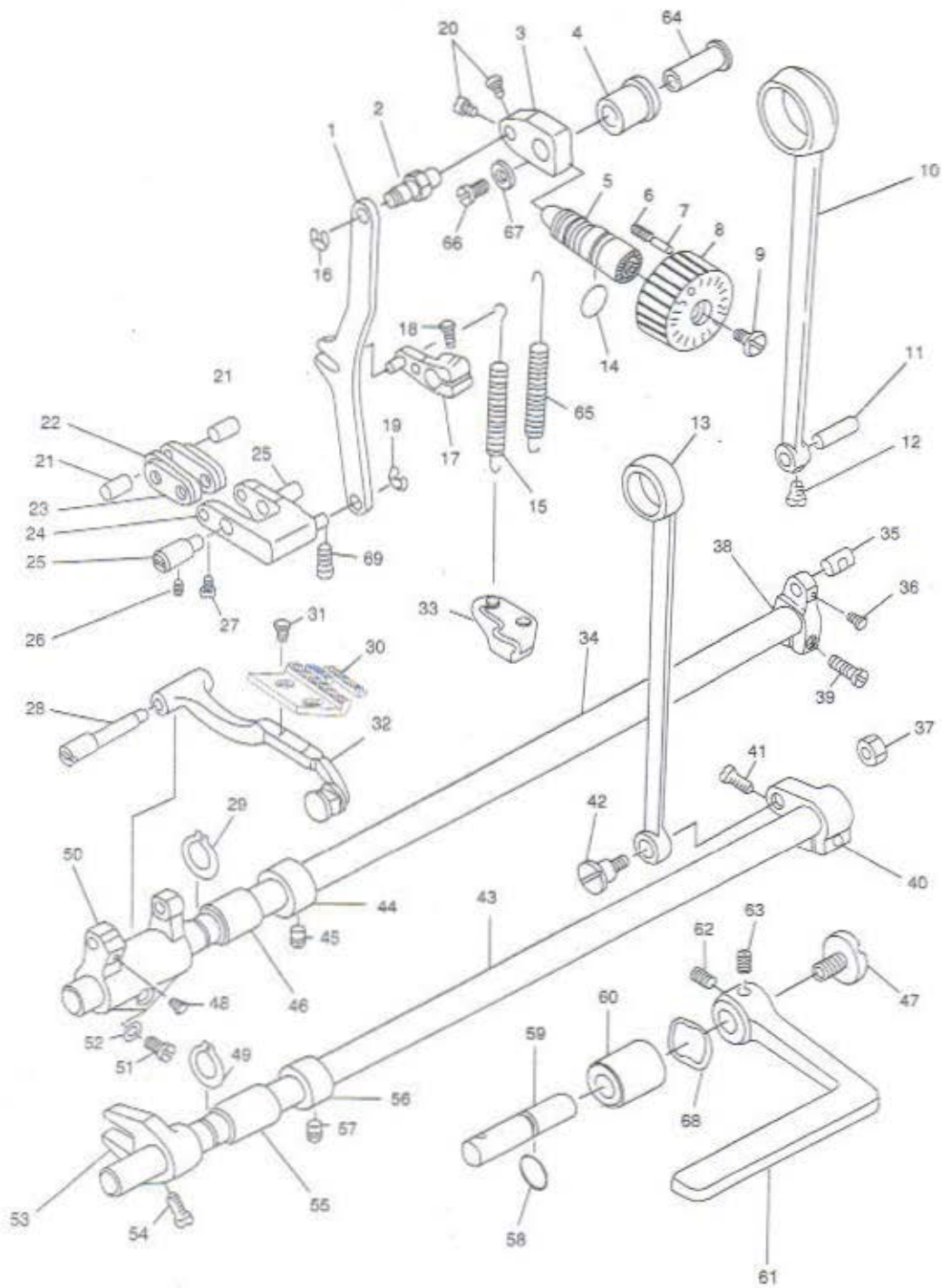

5. 送料分组件 Feed mechanism components

序号 REF. No.	件号 PART No.	名称 DESCRIPTION	数量 QTY	薄、中厚料 For Light medium-heavy materials	厚料 For heavy materials	皮革料 For leather materials
1	GH342-8	倒送料连杆 Feed adjust rod	1	☆		
	GH355-8	倒送料连杆 Feed adjust rod	1		☆	☆
2	GX212-8	倒送料连杆销 Feed regulator pin	1	☆		
	GX223-8	倒送料连杆销 Feed regulator pin	1		☆	☆
3	GR654-8	送料调节器 Feed regulator	1	☆		
	GR814-8	送料调节器 Feed regulator	1		☆	☆
4	GO274-8	送料调节器轴套 Feed regulator bushing	1	☆	☆	☆
5	GS343-8	送料调节螺栓 Screw	1	☆	☆	☆
6	GW191-8	送料距锁合簧 Spring	1	☆	☆	☆
7	GX211-8	送料距锁合销 Pin	1	☆	☆	☆
8	GR652-8	送料距旋钮 Feed dial	1	☆		
	GR813-8	送料距旋钮 Feed dial	1		☆	☆
9	GS342-8	送料距旋钮螺钉 Screw	1	☆	☆	☆
10	GH214-8	送料连杆 Connecting rod	1	☆		
	GH353-8	送料连杆 Connecting rod	1		☆	☆
11	GX204-8	送料连杆销 Pin	1	☆	☆	☆
12	GS333-8	送料连杆销螺钉9/64×40L=6 Screw 9/64×40L=6	1	☆	☆	☆
13	GH218-8	拾牙连杆 Connecting rod	1	☆	☆	☆
14	GR653-8	送料调节螺栓O型圈 Rubber ring	1	☆	☆	☆
15	GW192-8	倒送料拉簧 Spring	1	☆		
	GW204-8	倒送料拉簧 Spring	1		☆	☆
16	GR625-8	倒送料连杆挡圈 Snap ring	1	☆	☆	☆
17	GH344	倒送料曲柄部件 Reverse feed arm ASM	1	☆		
	GH357	倒送料曲柄部件 Reverse feed arm ASM	1		☆	☆
18	GS346-8	倒送料曲柄螺钉 Screw	1	☆		
	GS407-8	倒送料曲柄螺钉 Screw	1		☆	☆
19	GR625-8	倒送料连杆挡圈 Snap ring	1	☆	☆	☆
20	GS311-8	连杆销螺钉9/64×40L=6 Screw9/64×40L=6	2	☆	☆	☆
21	GX205-8	短摆动板连接销 Pin	2	☆	☆	☆
22	GR639-8	送料长摆动板 Link (long)	2	☆	☆	☆
23	GR640-8	送料短摆动板 Link (short)	2	☆	☆	☆
24	GR641/2-8	倒送料摆动板座部件 Feed adusting ASM	1	☆		
	GR811/2-8	倒送料摆动板座部件 Feed adusting ASM	1		☆	☆
25	GX207-8	送料摆动板座左右销 Adusting link shaft	2	☆	☆	☆
26	GS48	左右销螺钉15/64×28L=7 Screw15/64×28L=7	2	☆	☆	☆
27	GS333-8	连杆销螺钉9/64×40L=6 Screw9/64×40L=6	1	☆	☆	☆
28	GX222-8	牙架销 Feed bar shaft	1	☆	☆	☆
29	GR643-8	送料轴轴用挡圈 Retaining ring	1	☆	☆	☆
30	GM165-8	送料牙 Feed dog	1	☆		
	GM174-8	送料牙 Feed dog	1		☆	☆
31	GS337-8	送料牙螺钉1/8×44L=6 Screw 1/8×44L=6	2	☆	☆	☆
32	GR648	牙架部件 Feed bar ASM	1	☆		
	GR810	牙架部件 Feed bar ASM	1		☆	☆

5. 送料分组件 Feed mechanism components

序号 REF. No.	件号 PART No.	名称 DESCRIPTION	数量 QTY	薄、中厚料 For Light medium-heavy materials	厚料 For heavy materials	皮革料 For leather materials
33	GR657-8	拉簧固定板 Feed spring hook	1	☆		
	GR816-8	拉簧固定板 Feed spring hook	1		☆	☆
34	GZ235-8	送料轴 Feed rocker shaft	1	☆	☆	☆
35	GX208-8	送料曲柄销 Pin	1	☆	☆	☆
36	GS333-8	曲柄销螺钉9/64×40L=6 Screw9/64×40L=6	1	☆	☆	☆
37	GL142-8	拾牙连杆轴位螺母9/32×28 Nut	1	☆	☆	☆
38	GH215-8	送料曲柄 Feed rocker	1	☆		
	GH354-8	送料曲柄 Feed rocker	1		☆	☆
39	GS334-8	送料曲柄螺钉3/16×28L=15.5 Screw3/16"×28L=15.5	1	☆	☆	☆
40	GH217-8	拾牙后曲柄 Lifting rocker	1	☆	☆	☆
41	GS334-8	拾牙后曲柄螺钉3/16×28L=15.5 Screw3/16×28L=15.5	1	☆	☆	☆
42	GS341-8	拾牙连杆轴位螺钉 Screw	1	☆	☆	☆
43	GZ236-8	拾牙轴 Feed driving shaft	1	☆	☆	☆
44	GR589-8	送料轴挡圈 Thrust collar	1	☆	☆	☆
45	GS167	送料轴挡圈螺钉1/4×40L=6 Screw1/4×40L=6	2	☆	☆	☆
46	GO273-8	送料轴前轴套 Feed rocker shaft bushing	1	☆	☆	☆
47	GS344-8	送料调节器轴端螺钉 Screw 11/64"×40L=7	1	☆		
	GS051	倒送料轴端螺钉 Screw 3/16"×28L=7	1		☆	☆
48	GS336-8	牙架销螺钉11/64×40L=7 Screw 3/16"×28L=7	1	☆	☆	☆
49	GR634	拾牙轴轴用挡圈 Retaining ring	1	☆	☆	☆
50	GR807-8	牙架座 Feed bar driving crank	1	☆	☆	☆
51	GS142	牙架座螺钉3/16×28L=14 Screw 3/16"×28L=14	1	☆	☆	☆
52	GR658	复位板 Washer	1	☆		
53	GH216-8	拾牙叉形曲柄 Lifting fork	1	☆	☆	☆
54	GS340-8	拾牙叉形曲柄螺钉11/64×40L=10.5 Screw 11/64"×40L=10.5	1	☆	☆	☆
55	GO273-8	拾牙轴前轴套 Feed rocker shaft bushing	1	☆	☆	☆
56	GR589-8	拾牙轴挡圈 Thrust collar	1	☆	☆	☆
57	GS167	拾牙轴挡圈螺钉1/4×40L=6 Screw1/4"×40L=6	2	☆	☆	☆
58	GR424-8	倒送料轴O型圈 Rubber ring	1	☆	☆	☆
59	GZ237-8	倒送料轴 Reverse feed shaft	1	☆		
	GZ253-8	倒送料轴 Reverse feed shaft	1		☆	☆
60	GO275-8	倒送料轴轴套 Bushing	1	☆	☆	☆
61	GR656-8	倒送料扳手 Reverse feed controllever	1	☆	☆	☆
62	GS319-8	倒送料扳手螺钉1/4×40L=8 Screw1/4"×40L=8	1	☆	☆	☆
63	GS319-8	倒送料扳手定位螺钉1/4×40L=8 Screw1/4"×40L=8	1	☆	☆	☆
64	GZ254-8	送料调节器轴 Feed adjusting shaft	1		☆	☆
65	GW193-8	摆动板座复位簧 Reverse feed spring	1	☆		
	GW205-8	摆动板座复位簧 Reverse feed spring	1		☆	☆
66	GS408-8	送料调节器轴螺钉 Screw	1		☆	☆
67	GR817-8	送料调节器轴垫圈 Washer	1		☆	☆
68	GR815-8	倒送料轴轴端垫圈 Washer	1		☆	☆
69	GS347	复位板螺钉 Screw	2	☆		

6. 润滑分组件 Oil lubrication components

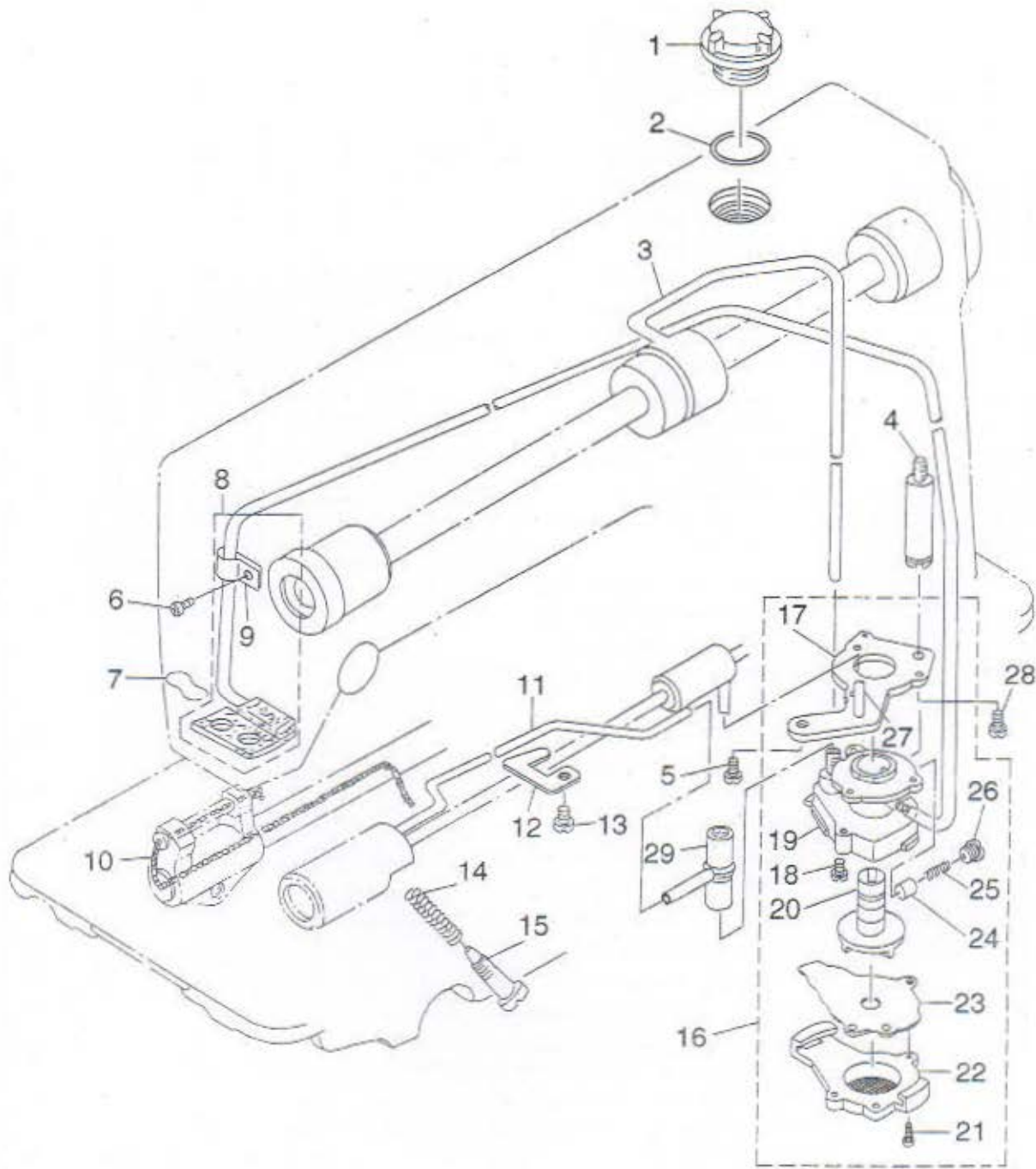

6、润滑分组件 Oil lubrication components

序号 REF. No.	件 号 PART No.	名 称 DESCRIPTION	数量 QTY	薄、中厚料 For Light medium-heavy materials	厚料 For heavy materials	皮革料 For leather materials
1	GR672-8	油窗 Oil sight window	1	☆	☆	☆
2	GR673-8	油窗O型圈 Rubber ring	1	☆	☆	☆
3	GR669-8	上轴供油管 Main shaft oil tube	1	☆	☆	☆
4	GS351-8	油泵连接螺柱 Oil pump support	1	☆	☆	☆
5	GS353-8	油泵螺钉15/64×28L=9 Screw15/64×28L=9	1	☆	☆	☆
6	GS310-8	回油管夹螺钉3/16×28L=6 Screw3/16×28L=6	1	☆	☆	☆
7	GR678-8	回油毡夹 Oil felt presser	1	☆	☆	☆
8		回油管组件 Oil return tube ASM	1	☆	☆	☆
9	GR675-8	回油管夹 Holder	1	☆	☆	☆
10	GR644-8	送料轴油线 Oil wick	1	☆	☆	☆
11	GR670-8	旋梭供油管 Oil tube	1	☆	☆	☆
12	GR671-8	旋梭供油管压板 Tube holder lower	1	☆	☆	☆
13	GS353-8	压板螺钉15/64×40L=9.5 Screw15/64×40L=9.5	1	☆	☆	☆
14	GW195-8	旋梭油量调节簧 Spring	1	☆	☆	☆
15	GS352-8	旋梭油量调节螺钉 Oil adjusting screw	1	☆	☆	☆
16	GR659/19-8	油泵部件 Oil pump ASM	1	☆	☆	☆
17	GR660-8	油泵安装板 Oil pump installing base	1	☆	☆	☆
18	GS348-8	油泵安装螺钉M3×8 Screw M3×8	3	☆	☆	☆
19	GR662-8	油泵体 Oil pump	1	☆	☆	☆
20	GR663-8	油泵叶轮 Oil pump impeller	1	☆	☆	☆
21	GS349-8	油泵盖螺钉 Screw	3	☆	☆	☆
22	GR665-8	油泵盖 Oil pump cover	1	☆	☆	☆
23	GR664-8	油泵叶轮托板 Oil pump impeller cover	1	☆	☆	☆
24	GR666-8	回油柱塞 Plunger	1	☆	☆	☆
25	GW194-8	柱塞簧 Plunger spring	1	☆	☆	☆
26	GS350-8	柱塞螺钉 Plunger screw	1	☆	☆	☆
27	GR667-8	下轴供油管 Hook driving shaft oil tube	1	☆	☆	☆
28	GS328-8	螺柱连接螺钉11/64×40L=9.5 Screw11/64×40L=9.5	1	☆	☆	☆
29	GR668-8	供油管接头 Oil tube joint	1	☆	☆	☆

7. 油盘分组件 Oil reservoir components

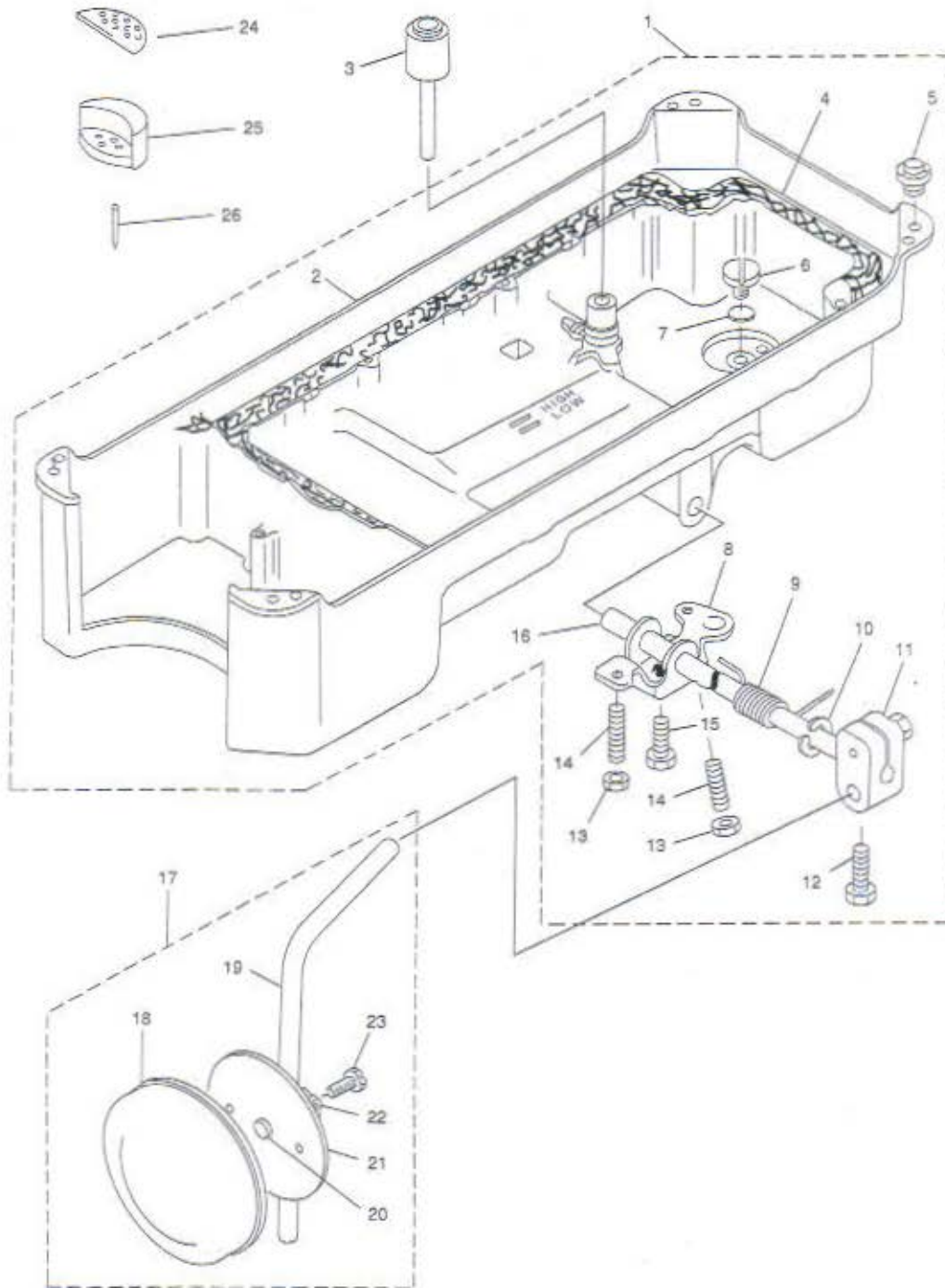

7. 油盘分组件 Oil reservoir components

序号 REF. No.	件号 PART No.	名称 DESCRIPTION	数量 QTY	薄、中厚料 For Light medium-heavy materials	厚料 For heavy materials	皮革料 For leather materials
1	GR680/25-8	油盘部件 Oil reservoir ASM	1	☆	☆	☆
2	GR681-8	油盘 Oil reservoir ASM	1	☆	☆	☆
3	GH344-8	抬压脚顶销 Top pin of lifting presser foot	1	☆	☆	☆
4	GR682-8	油盘垫 Oil reservoir gasket	1	☆	☆	☆
5	GR683-8	机头座垫 Head gasket	4	☆	☆	☆
6	GS355-8	排油孔螺钉 Screw	1	☆	☆	☆
7	GR684-8	排油孔螺钉O形圈 Rubber ring	1	☆	☆	☆
8	GH345-8	抬压脚双向曲柄 Two-way crank of lifting presser foot	1	☆	☆	☆
9	GW196-8	双向曲柄扭簧 Twisting spring of two way crank	1	☆	☆	☆
10	GR688-8	抬压脚轴开口挡圈 Snap ring	1	☆	☆	☆
11	GR689-8	抬压脚操纵杆节头 Bracket	1	☆	☆	☆
12	GS358-8	操纵杆节头螺钉9/32×20L=20 Screw9/32×20L=20	1	☆	☆	☆
13	GL170-8	双向曲柄限位调节螺母15/64×28 Nut 15/64×28	2	☆	☆	☆
14	GS357-8	双向曲柄限位调节螺钉15/64×28L=30 Screw15/64×28L=30	2	☆	☆	☆
15	GS356-8	双向曲柄螺钉 Screw	1	☆	☆	☆
16	GZ238-8	抬压脚轴开口挡圈 Knee pressing shaft	1	☆	☆	☆
17	GR690/6-8	操纵杆部件 Knee pressing plate ASM	1	☆	☆	☆
18	GR693-8	操纵板软垫 Knee pressing plate cover	3	☆	☆	☆
19	GR691-8	操纵杆 Knee pressing plate rod	1	☆	☆	☆
20	GR694-8	操纵杆垫 Knee pressing plate rubber	1	☆	☆	☆
21	GR692-8	操纵板 Knee pressing plate	3	☆	☆	☆
22	GR695-8	操作杆节头 Knee pressing plate holder	1	☆	☆	☆
23	GS359-8	节头螺钉15/64×28L=15 Screw15/64×28L=15	1	☆	☆	☆
24	GR686-8	油盘座垫 Oil reservoir cushion	2	☆	☆	☆
25	GR687-8	油盘支座 Oil reservoir seat	2	☆	☆	☆
26	GBX141-8	油盘座钉 Oil reservoir nail	4	☆	☆	☆

8. 皮带罩、绕线器与过线架分组件 Belt cover, bobbin winder & thread stand components

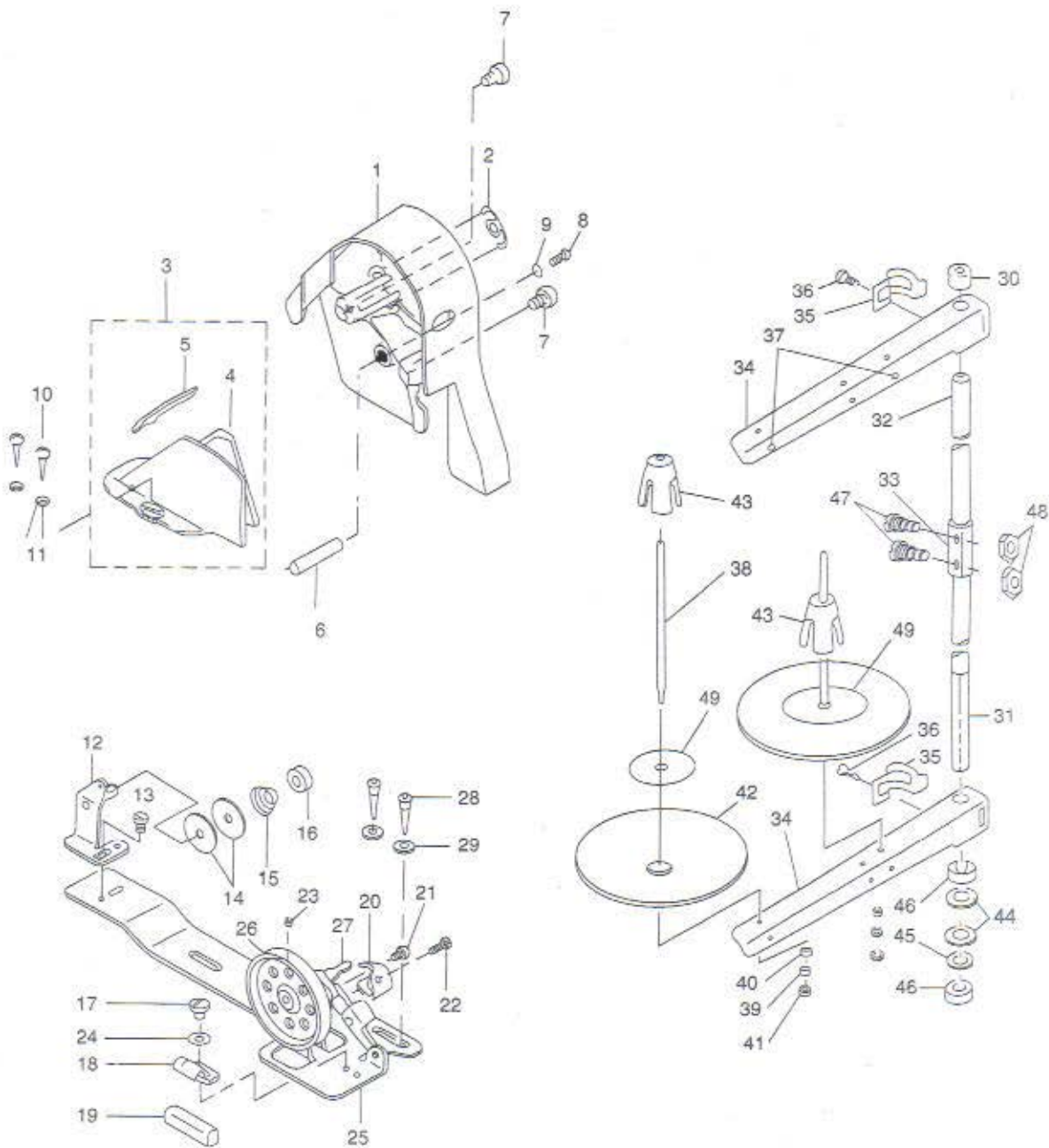

8. 皮带罩、绕线器与过线架分组件 Belt cover, bobbin winder & thread stand components

序号 REF. No.	件号 PART No.	名称 DESCRIPTION	数量 QTY	薄、中厚料 For Light medium-heavy materials	厚料 For heavy materials	皮革料 For leather materials
1	GK154-8	上轮前罩壳 Belt cover	1	☆	☆	☆
2	GR698-8	前罩壳安装架 Belt cover cap	1	☆	☆	☆
3	GK155/3-8	上轮后罩壳部件 Rear belt cover ASM	1	☆	☆	☆
4	GK156-8	上轮后罩壳 Rear belt cover	1	☆	☆	☆
5	GK157/2-8	后罩壳盖部件 Rear cover ASM	1	☆	☆	☆
6	GS361-8	后罩壳支柱 Belt cover support	1	☆	☆	☆
7	GS360-8	前罩壳紧固螺钉 Screw	2	☆	☆	☆
8	GS362-8	支柱螺钉 Screw	1	☆	☆	☆
9	GR699-8	螺钉垫圈 Washer	1	☆	☆	☆
10	GBS204-8	后罩壳安装木螺钉 Screw	2	☆	☆	☆
11	GB4210-8	木螺钉垫圈 Washer	2	☆	☆	☆
12		过线架座部件 Thread tension ASM	1	☆	☆	☆
13	GS368-8	过线架紧固螺钉11/64×40L=7.8 Screw11/64×40L=7.8	1	☆	☆	☆
14	GR712-8	过线夹线板 Thread tension Disk	2	☆	☆	☆
15	GW199-8	过线夹线簧 Thread tension spring	1	☆	☆	☆
16	GL171-8	过线夹线螺母 Tension nut	1	☆	☆	☆
17	GS365-8	制动垫夹紧螺钉11/64×40L=5 Screw11/64×40L=5	1	☆	☆	☆
18	GR709-8	制动垫夹 Presser plate	1	☆	☆	☆
19	GR708-8	绕线轮制动垫 Rubber brake	1	☆	☆	☆
20	GW198-8	满线跳板簧 Positioning finger	1	☆	☆	☆
21	GS364-8	绕线架连杆轴位螺钉1/8×44 L=12 Screw1/8×44 L=12	1	☆	☆	☆
22	GS366-8	满线跳板螺钉 Screw	1	☆	☆	☆
23	GS363-8	绕线轮螺钉 Screw	1	☆	☆	☆
24	GR819-8	制动垫夹紧螺钉垫圈 Washer	1	☆	☆	☆
25		绕线座部件 Bobbin winder ASM	1	☆	☆	☆
26	GP148-8	绕线轮 Bobbin wheel	1	☆	☆	☆
27	GZ239-8	绕线轴 Bobbin shaft	1	☆	☆	☆
28	GBS204-8	绕线器木螺钉 Wood screw	2	☆	☆	☆
29	GBR210-8	绕线器木螺钉垫圈 Washer	2	☆	☆	☆
30	GR713-8	线架杆顶防护橡皮 Spool rest rod cap	1	☆	☆	☆
31	GZ240-8	线架杆下节 Spool rest lower rod	1	☆	☆	☆
32	GZ241-8	线架杆上节 Spool rest upper rod	1	☆	☆	☆
33	GR714-8	接架杆接头 Spool rest joint	1	☆	☆	☆
34	GR715-8	线架过线杆 Thread guide ASM	2	☆	☆	☆
35	GR716-8	线架过线夹 Thread guide ASM joint	2	☆	☆	☆
36	GS369-8	线架过线夹螺钉 Screw	2	☆	☆	☆
37	GR717-8	过线圈 Thread guide ring	2	☆	☆	☆
38	GS370-8	线盘钉 Spool pin	2	☆	☆	☆
39	GR718-8	线盘钉弹簧垫 Spring washer	2	☆	☆	☆
40	GR719-8	线盘钉垫圈 Washer	2	☆	☆	☆
41	GL172-8	线盘打螺母 Nut	2	☆	☆	☆
42	GR720-8	线盘 Spool rest	2	☆	☆	☆

8. 皮带罩、绕线器与过线架分组件 Belt cover, bobbin winder & thread stand components

序号 REF. No.	件 号 PART No.	名 称 DESCRIPTION	数量 QTY	薄、中厚料 For Light medium-heavy materials	厚料 For heavy materials	皮革料 For leather materials
43	GR721-8	线团防松垫 Spool retainer	2	☆	☆	☆
44	GR722-8	线架杆紧固螺母垫圈 Nut washer	2	☆	☆	☆
45	GR723-8	紧固螺母弹簧垫圈 Spring washer	1	☆	☆	☆
46	GL173-8	线架杆紧固螺母 Nut	2	☆	☆	☆
47	GS401-8	接架杆接头螺钉 Screw	2	☆	☆	☆
48	GL134-8	接架杆接头螺母 Nut	2	☆	☆	☆
49	GR750-8	线盘轮垫 Spool retainer	2	☆	☆	☆

9. 型号R滚轮压脚专用件 Special parts for model "R" with roller presser foot

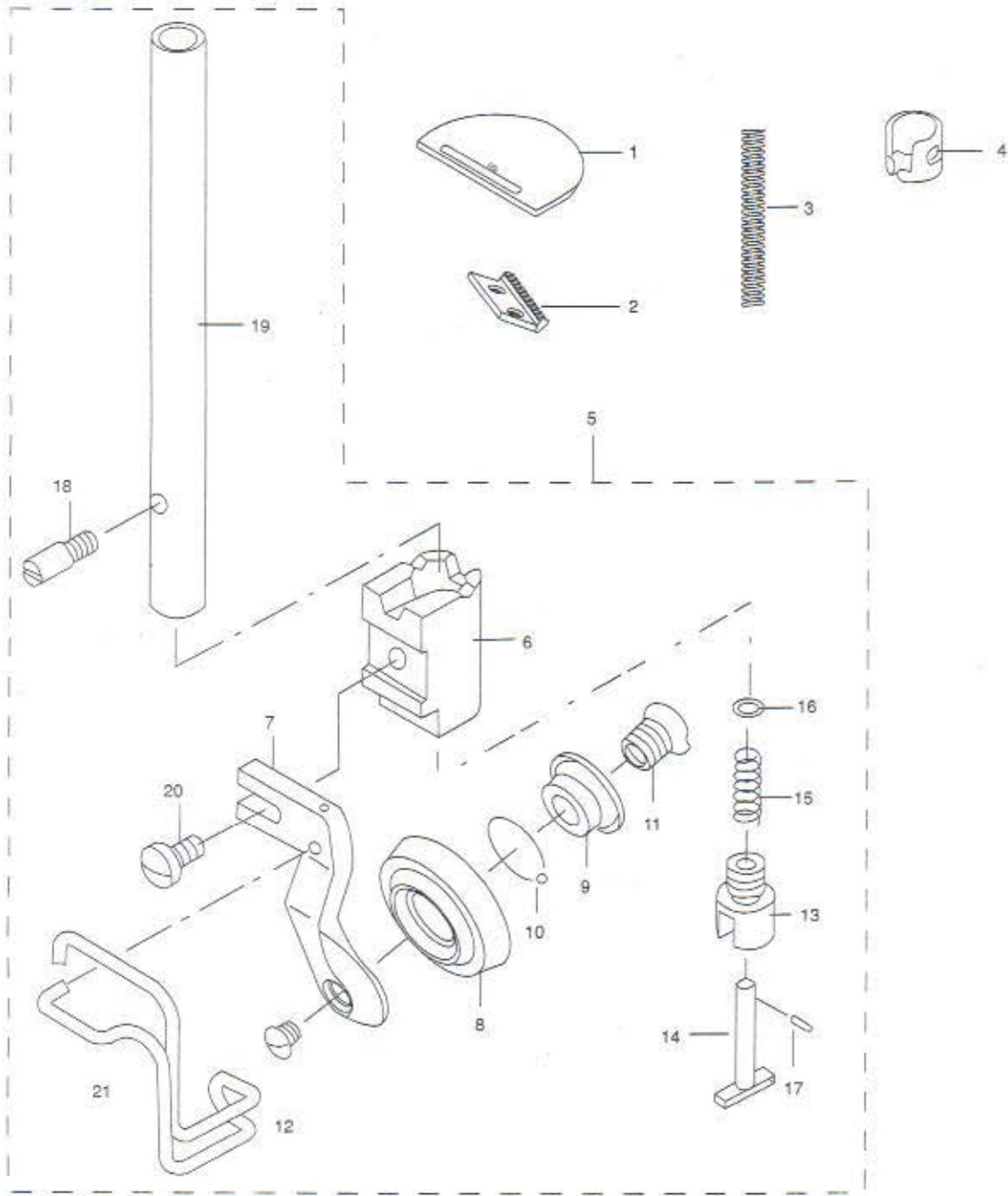

9. 型号R滚轮压脚专用件 Special parts for model "R" with roller presser foot

序号 REF. No.	件号 PART No.	名称 DESCRIPTION	数量 QTY	薄、中厚料 For Light medium-heavy materials	厚料 For heavy materials	皮革料 For leather materials
1	GM175-8	针板 Needle plate	1	☆	☆	☆
2	GM176-8	送料牙 Feed dog	1	☆	☆	☆
3	GW206-8	调压簧 Presser spring	1	☆	☆	☆
4	GR820-8	针杆线钩 Needle bar thread guide	1	☆	☆	☆
5	GR821-8	滚轮压脚组件 Roller presser foot ASM	1	☆	☆	☆
6	GR822-8	滚轮压脚座 Roller presser seat	1	☆	☆	☆
7	GR823-8	滚轮压脚柄 Roller presser handle	1	☆	☆	☆
8	GP155-8	滚轮 Roller	1	☆	☆	☆
9	GO292-8	滚轮轴套 Roller bushing	1	☆	☆	☆
10	GR824-8	钢球 Steel ball	48	☆	☆	☆
11	GS409-8	滚轮轴套调整螺钉 Screw	1	☆	☆	☆
12	GS410-8	滚轮轴套固定螺钉 Screw	1	☆	☆	☆
13	GR825-8	弹簧座 Spring seat	1	☆	☆	☆
14	GZ256-8	弹簧销轴 Spring shaft	1	☆	☆	☆
15	GW207-8	弹簧 Spring	1	☆	☆	☆
16	GR826-8	弹簧垫圈 Spring washer	1	☆	☆	☆
17	GX225-8	弹簧垫圈销 Pin	1	☆	☆	☆
18	GS411-8	滚轮压脚座紧固螺钉 Screw	1	☆	☆	☆
19	GZ257-8	压杆 Presser foot	1	☆	☆	☆
20	GS412-8	滚轮压脚柄紧固螺钉 Screw	1	☆	☆	☆
21	GR827-8	保针架 Finger protector	1	☆	☆	☆

10. 附件 Accessories

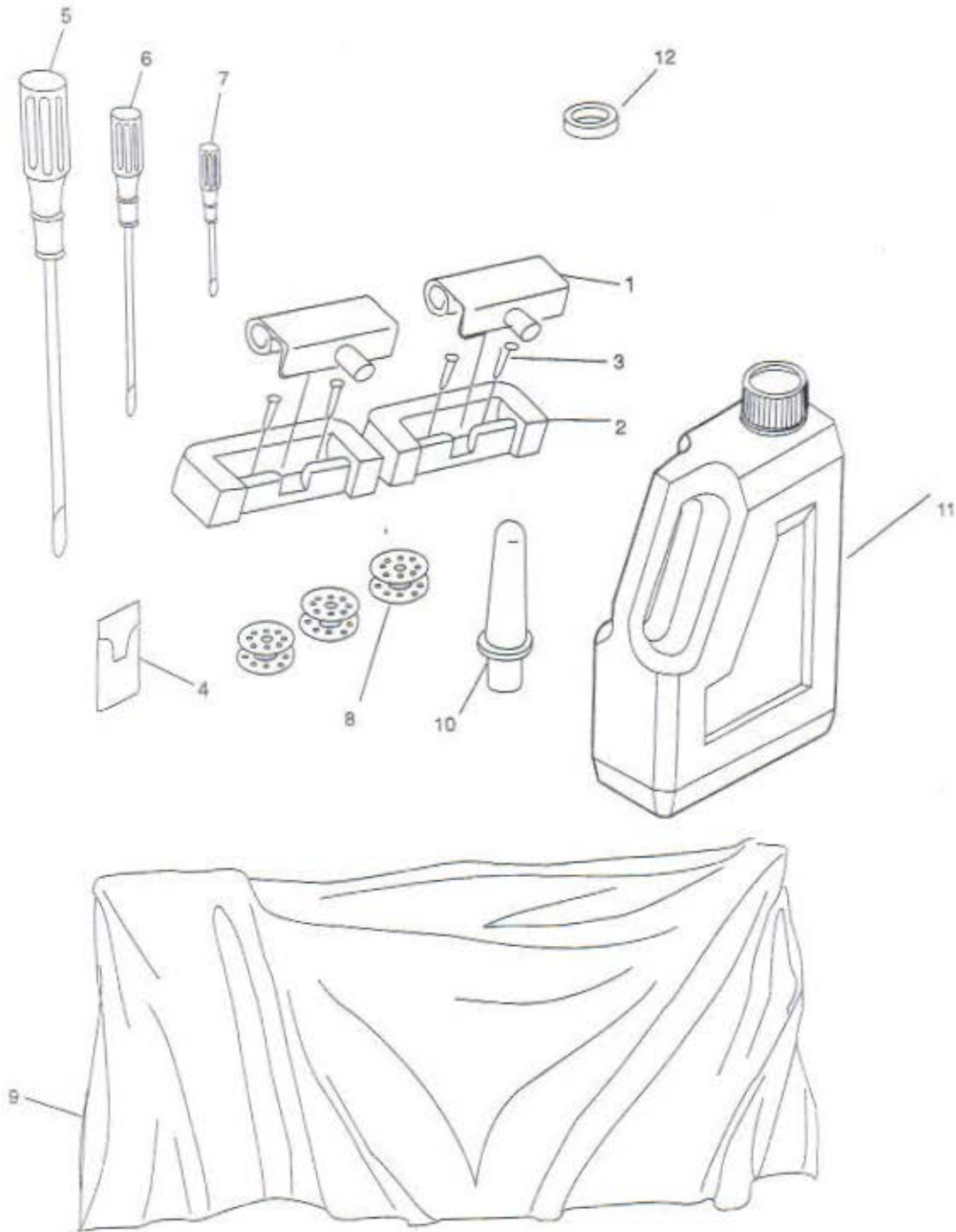

10、附件 Accessories

序号 REF. No.	件号 PART No.	名称 DESCRIPTION	数量 QTY	薄、中厚料 For Light medium-heavy materials	厚料 For heavy materials	皮革料 For leather materials
1	GR696/2-8	机头连接钩部件 Head connecting hook	2	☆	☆	☆
2	GR697-8	机头连接钩座 Head connecting hook socket	2	☆	☆	☆
3	GBX142-8	机头连接钩座钉 Head connecting hook nail	4	☆	☆	☆
4	GV132-8	机针 Needles 1 bag	1包	☆	☆	☆
5	GR700-8	螺丝刀 (大) Screw driver (L)	1	☆	☆	☆
6	GR701-8	螺丝刀 (中) Screw driver(M)	1	☆	☆	☆
7	GR702-8	螺丝刀 (小) Screw driver(S)	1	☆	☆	☆
8	GN139-8	梭心 Bobbin	3	☆	☆	☆
9	GF101-8	机头罩 Head cover	1	☆	☆	☆
10	GBR211-8	机头支柱 Head pole	1	☆	☆	☆
11	GR703/3-8	油箱部件 Oil bottle with Oil	1	☆	☆	☆
12		油盘磁铁 Oil reservoir magnet	1	☆	☆	☆